

Many Special Xmas Features

NEWNES

1/-

PRACTICAL MECHANICS

EDITOR: F. J. GAMM
DECEMBER 1954



CHRISTMAS MAGIC; MECHANICAL GAMES FOR THE FESTIVE SEASON; MAKING XMAS CRACKERS AT HOME; MAKING A MODEL PADDLE STEAMER Etc., Etc.

Better light...
FOR BETTER WORK



Down a little!



Still nearer!



Right on the job!

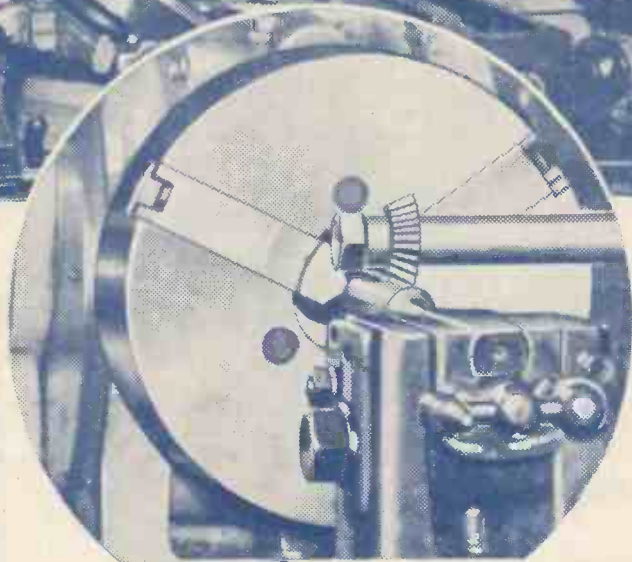

THIS IS HOW ANGLEPOISE LIGHTS
 UP THE JOB IN STRONG RELIEF—
 SAVING EYESTRAIN AND FATIGUE

However skilled a worker may be, he must 'see' the job. This applies especially in lathework, valve-grinding, on milling machines or power drills, etc., wherever adjustable close-to-the-job lighting is a sheer necessity.

ANGLEPOISE throws a clear shadowless light right on the work, not in the user's eyes and follows the job from any angle at a finger touch, degree by degree. It 'stays put' in any required position in the presence of heavily vibrating machinery and needs only a low power bulb for high class results. If you would like to know more about these fine lamps write for Booklet PM.

Sole Makers: HERBERT TERRY & SONS LTD
 Redditch · Worcestershire · England

TERRY ANGLEPOISE LAMPS

Pat. all countries

SOME
 ALTERNATIVE
 BASES FOR
 ALL MODELS

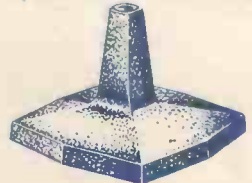

A HIGH SPEED LATHE

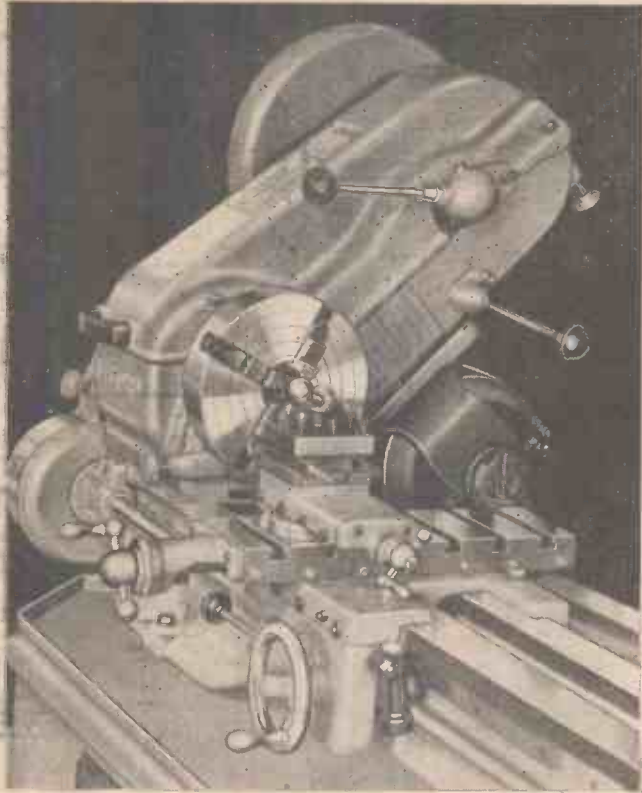

2,000 R.P.M. PLUS

- Fourteen Spindle Speeds from 25-2,150 r.p.m.
- Clutch Control to Drive Unit
- Large Boring Table to carry Rear Tool Post
- Attachments for Taper Turning, Dividing, Milling, Repetition Turning, etc.

3½" CENTRE HEIGHT 19" BETWEEN CENTRES

— THE —
— SUPER — 7 —
HIGH-SPEED LATHE

MYFORD

BEESTON · NOTTINGHAM · ENGLAND

Finest Soldering? Always specify
MULTICORE to be precise

ERSIN MULTICORE

Contains 5 cores of extra-active, non-corrosive Ersin Flux. Prevents oxidation and cleans surface oxides.

SIZE ONE CARTON

4 specifications for radio enthusiasts. **5/-**



Wherever precision soldering is essential, manufacturers, engineers and handymen rely on MULTICORE. There's a MULTICORE SOLDER just made for the job you have in hand. Here are some of them.

ARAX MULTICORE

FOR METAL FABRICATION

(Not wire to tag joints)
Contains 2 cores of Arax Flux—a flux so fast that even blued spring steel can be soldered without pre-cleaning. Flux residue is easily removed with water.

SIZE 8 CARTON

5/-



BIB WIRE STRIPPER AND CUTTER
The 3 in 1 tool. For stripping insulation without nicking wire, cutting without leaving rough edges and splitting extruded flex. **3/6**



HANDYMAN'S CARTON

6d. Sufficient for 200 average joints.



MANUFACTURERS ARE INVITED TO WRITE FOR DETAILS OF BULK PACKS AT BULK PRICES

MULTICORE *Tape Solder*
Melts with a Match! **1/-**

A real tin/lead solder containing cores of Ersin Flux. Needs no soldering iron or extra flux. PER CARD

MULTICORE SOLDERS LTD.

MULTICORE WORKS, HEMEL HEMPSTEAD, HERTS (BOXMOOR 3636)

LAY YOUR OWN FLOORS

Oak and Beech Flooring Blocks Free of Purchase Tax



Hardwood floors are not difficult to lay on concrete or wooden sub-floors. We supply kiln dried flooring blocks manufactured in Sweden from Prime quality Scandinavian Oak and Beech ready for laying with full instructions. At a modest cost you can transform concrete or softwood floors into beautiful polished Parquet floors that will last a lifetime, and add to the value of your property.

Beech 16/6

Per Sq. Yard

Oak 19/6

Per Sq. Yard

FULL DETAILS, SAMPLE AND LAYING INSTRUCTIONS ON APPLICATION

THE SURREYBOARD COMPANY, LIMITED

(Dept. PM.) · 72 HIGH STREET · CROYDON · SURREY

GAMAGES

FOR OUTSTANDING TOOL BARGAINS

1/3 h.p. HOOVER ELECTRIC MOTORS
Nearly HALF PRICE!

1-3rd Horse Power, 220/230 Volts. Split phase, continuous rated 1,425 R.P.M. Similar to illustration.

Last Price **GAMAGES** 5 GNS.
 £10.2.9 **PRICE**

Limited stock. Order Early.

Also **ENGLISH ELECTRIC**
 1/3 h.p. 230/250v. 1,440 r.p.m.,
 £8.17.6.

Carr. paid 50 miles radius of
 Holborn. Otherwise 6/9 Eng. &
 Wales, 9/6 Scotland.



'VISI-PART'
STANDS

For Workshop, Garage
 or in the Home.

20 Transparent Plastic Trays
 with 40 separate compartments.
 No searching! At a glance
 you have the item

you want.
 Strong aluminium tube
 pillars and
 crosspiece
 mounted on
 solid var-
 nished wood-
 en base.



Size 9 1/2 in. x 6 1/2 in.
 Height 15 in.
 Post & Pkg. 2/6. **70/-**

'TIDI-JAR' RACKS

for your workshop

Simply swing the
 required jar with its
 easily visible contents to
 the bottom and unscrew.
 All metal frame. Fits
 against the wall or under
 a shelf. Size: 14x10x10 in.



16-JAR MODEL
 Carr. & Pkg. 2/3. **25/3**

Gamages offer an adjustable
ROLL FEED
ABRASIVE FILE



12ft. of
 Abrasive
 Cloth on a
 reel,
 feeds the
 surface of 1 1/2 in. x 1 1/2 in.
 wide. ALWAYS SHARP. Used in
 the same manner as the conven-
 tional file. It will not
 wear out. Fitted with
 medium grit cloth. **17/6**
 Post & Pkg. 1/1.

EXTRA STRONG
STEEL TOOL BOXES

Exceptionally well-made and finished tool boxes.
 Fitted with removable inner tray and hinged lids.
 Hasp for padlock fastening. Enamelled Dark
 Green. Size 24 x 8 x 6 in.
 Weight, 17/18 lb. Carr. & Pkg., 4/- outside our van
 area. **BARGAIN** **27/6**
PRICE

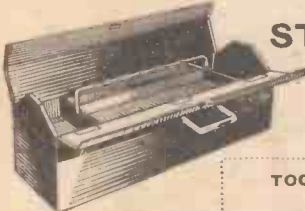

TOOL AND MOTOR CAR ACCESSORY
LIST FREE

GAMAGES, HOLBORN, LONDON, E.C.1. HOLBORN 8484.



To Young
 Engineers
 with
 Ambition

A CAREER IN THE MERCHANT NAVY. Here is an attractive opportunity for young and ambitious engineers.

The British Tanker Company (the shipping organisation of Anglo-Iranian Oil Company) operates one of the largest privately-owned tanker fleets in the world and offers young engineers every opportunity of reaching the highest ranks in the marine engineering profession.

If you are interested in ships and prepared, after qualifying periods of sea service, to take the necessary examinations, an extremely well-paid career is open to you in this vital branch of Britain's Merchant Navy.

TO QUALIFY: (1) You should be nearing the completion of your apprenticeship as a fitter or turner and must have had some experience on heavy machinery or power plant maintenance.

(2) You must have obtained your Ordinary National Certificate or be likely to obtain this before the completion of your apprenticeship.

If you are interested please write for further details to:-

The British Tanker Co. Ltd., Dept. PM.4

BRITANNIC HOUSE, FINSBURY CIRCUS, LONDON, E.C.2

You can Construct a

DOMESTIC REFRIGERATOR



HERMETICALLY
 SEALED UNITS.

We are the original Specialists and Complete Stockists of all Home Constructed Refrigeration requirements. Save Money! Build your own, either "Built in" or Cabinet to suit your own layout, using the latest modern self-contained units, ready to install. **NO MECHANICAL KNOWLEDGE REQUIRED, JUST WIRE UP.** Send 1/- for 20-page illustrated catalogue (post free) refunded with first order. Listing all types of units. Electric Compressor, Silent Electric, Gas and Oil. Cabinet Accessories, Refrigerant Gases. All Spares.

We supply the following 4 cu. ft. Refrigerator Plans. Price 5/- each. (Refundable.)

- BB/A/E Silent Electric.
- BB/A/G Silent Town and Calor Gas.
- BB/A/P Silent Paraffin.
- BB/C Electric (compressor type).
- BB/H Electric Hermetically Sealed Unit Type (latest design).

BRAID BROS.

FOR HOME REFRIGERATOR CONSTRUCTION

50 BIRCHWOOD AVENUE :: HACKBRIDGE :: SURREY

Tel. : Wallington 9309



Illustrated is our 4 cu. ft. Silent Electric Model with our one-piece White Vitreous Liner. Built to our Plan BB/A/E.

*** PLEASURE AND PROFIT**

SILK SCREEN PRINTER
 with ALL SUPPLIES
 & FREE COURSE!

PRINTS IN SIX COLOURS

This is the great new printing and colouring process for amateurs or professionals alike and all handcraft workers. Its versatility is enormous. It will print a few copies, or hundreds, to a professional standard, in solid colours, or intricate designs, on cloth, paper, wood, etc. Print notices, greeting cards, drawings, paintings in full colour, photographs, type-script. Fluorescent colours, suede flock and novelty finishes, transfer papers for printing your own transfers also available. Can also be used as first-rate duplicator with any typewriter. Nowhere else is such a large and comprehensive outfit offered for so little money. Hundreds of customers testify to the quality and amazing value. Do not miss this opportunity.

—ON PAPER, WOOD, CLOTH, PLASTICS, etc.
AMERICAN PUBLISHERS SERVICE
 (Graphic Arts Div.),
 DOCKING ROAD, SEDGFORD, NORFOLK

This IS the **BARGAIN OF THE YEAR**

COMPARE THE VALUE
SEE WHAT YOU GET!

Large 16 in. x 12 in. PRINTING FRAME. Stout Laminated WOODEN BASE.

Patented ADJUSTABLE HINGES (for printing on material up to 1/2 in. thick).
 Fine Quality SQUEEGEE
 SIX CONTAINERS COL-
 OURS—Red, Blue, Yellow,
 Green, Black, White.
 STENCIL FILM (design traced and applied with hot iron).

STENCIL CUTTERS and HOLDER. Register Guides, Masking Tape, etc., etc. And FREE 10/- COURSE giving step by step procedure for every application of process, including PHOTO STENCILS, DAYGLO, FLOCK finishes, etc.

for **47/6** post paid
REFUND GUARANTEED
 IF NOT APPROVED
 WITHIN 7 DAYS.

2 YEARS GUARANTEE

with the

BURGOYNE

8 VALVE Radiogram Chassis

With a push-pull output giving 8 watts undistorted quality reproduction and using negative feedback, this fine chassis is supplied for those connoisseurs wanting only the best, at a price within their means.

SPECIFICATION ★Illuminated full vision coloured tuning scale 1 1/2 in. x 6 1/2 in. ★Separate bass and treble controls for cut and lift. ★Wavebands 16-50 ; 190-550 ; 1000-2000 metres. ★Magic eye tuning indicator and precision fly-wheel tuning. ★Speech coil impedance 3 or 15 ohms. ★Extension speaker sockets. ★Size 9 1/2 in. high x 13 in. wide, 8 in. deep—chassis height 2 1/2 in.



22GNS.
 200-250v. A.C.

Carriage and packing 7/6

YOURS for ONLY 46/3 deposit
 balance over 12 or 18 months.

E & G MAIL ORDER SUPPLY CO. The Radio Centre

33 Tottenham Court Road, London, W.1.

Phone : MUSEum 6667.

All set for a **BASSETT-LOWKE** Christmas



There's lasting joy in a model train set gift. From the Bassett-Lowke Workshops comes a fascinating choice of sets—Steam driven trains—electric powered trains—clockwork trains. All are here in a variety of types to suit the model enthusiast's preference and every pocket. This page gives a glimpse of the copious selection to be found in the catalogue mentioned below. Choose how you will, your gift will have the exclusive appeal which is coupled with the greatest name in Model Railways . . . BASSETT-LOWKE.

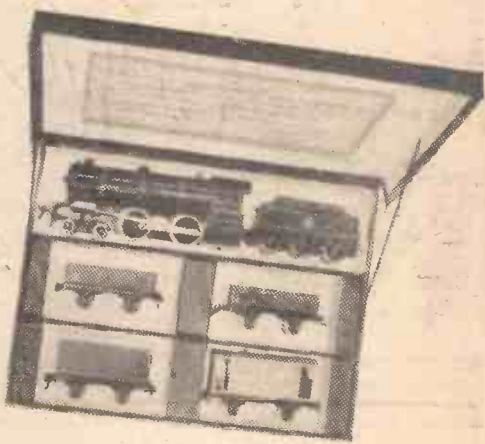

STEAM No. 754/10 "ENTERPRISE" Passenger set. 4-4-0 Locomotive and Tender. 2 Passenger coaches; 12 curved, 6 straight tinned steel plate rails to form a 7ft. x 4ft. oval track. Packed in two presentation boxes. Complete, £16/2/6.

STEAM No. 754/9 "ENTERPRISE" Goods set. 4-4-0 Locomotive and Tender. 2 open goods vans, 1 covered van, 1 Guard's Brake van; 12 curved, 6 straight tinned steel plate rails to form 7ft. x 4ft. oval track. Packed in two presentation boxes. Complete, £14/7/6.

ELECTRIC No. 754/5 British Railways "Compound" Locomotive. 2 all-steel Passenger coaches, oval of Bassett-Lowke Scale Model P.W. steel track, 10ft. 6in. x 6ft.; electric connecting rail. Packed in two presentation boxes. Complete, £18/10/-.

ELECTRIC No. 754/6 "PRINCE CHARLES" Passenger set. 4-4-0 Locomotive. 2 coaches; oval of Bassett-Lowke Scale Model P.W. steel track, 10ft. 6in. x 6ft.; electric connecting rail. Packed in two presentation boxes. Complete, £15/15/-.

ELECTRIC No. 754/8 6-coupled Tender Locomotive. Train of 4 all-steel body goods vehicles comprising 2 open vans, 1 covered van, 1 Guard's Brake van; 10ft. 6in. x 6ft. oval of Scale Model P.W. track. Packed in two presentation boxes. Complete, £14/10/-.

ELECTRIC No. 754/7 British Railways 6-coupled Tank Locomotive. Train of 4 all-steel body goods vehicles comprising 2 open vans, 1 covered van, 1 Guard's Brake van. Oval of Bassett-Lowke Scale Model P.W. steel track. 10ft. 6in. x 6ft.; electric connecting rail. Packed in two presentation boxes. Complete, £17/12/6.

CLOCKWORK No. 754/1 Passenger train. British Railways "Compound" Locomotive. 2 all-steel Passenger coaches; 7ft. x 4ft. oval of 12 curved, 6 straight lengths of tinned steel track. Packed in two presentation boxes. Complete, £12/17/6.

CLOCKWORK 754/2 Passenger Train. "PRINCE CHARLES" 4-4-0 Locomotive. 2 all-steel coaches; 7ft. x 4ft. oval of 12 curved, 6 straight lengths of tinned steel track. Packed in two presentation boxes. Complete, £10/7/6.

CLOCKWORK No. 754/3 Goods train. British Railways 6-coupled Tank Locomotive. Train of 4 all-steel body goods vehicles comprising 2 open vans, 1 covered van, 1 Guard's Brake van; 7ft. x 4ft. oval of 12 curved, 6 straight lengths of tinned steel track. Packed in two presentation boxes. Complete, £11/15/-.

CLOCKWORK No. 754/4 Goods train. 6-coupled Tender Locomotive of great power. 4 all-steel body goods vehicles. 7ft. x 4ft. oval of 12 curved, 6 straight lengths of tinned steel track. Packed in two presentation boxes. Complete, £9/5/-.

PERMANENT WAY

Scale Model tracks of 10ft. 6in. x 6ft. oval to give still better appearance and performance to Steam and Clockwork train sets, can be supplied as extra for £3/10/-.

ELECTRICALLY OPERATED

Bassett-Lowke Locomotives are fitted with efficient permanent magnet motors wired for running on 12 volts direct current. They may be operated from 200-250 A.C. house mains by rectifier-resistance units, £4/17/6. The youngest user is safe with Bassett-Lowke electric trains.



Great New Guide ★ for Model Railway Enthusiasts

The New Bassett-Lowke catalogue is packed with interest for the model enthusiasts—and crowded with ideas for Christmas givers. Send 2/- to Department MR/12 for this 100-page, fully illustrated book—the most comprehensive ever issued by Bassett-Lowke.

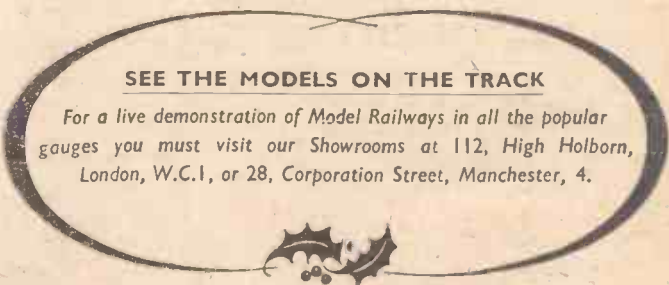

SEE THE MODELS ON THE TRACK

For a live demonstration of Model Railways in all the popular gauges you must visit our Showrooms at 112, High Holborn, London, W.C.1, or 28, Corporation Street, Manchester, 4.



BASSETT-LOWKE LTD. Head Office and Works NORTHAMPTON

London Showrooms: 112 High Holborn, W.C.1. Manchester Showrooms: 28 Corporation St., 4.

A FACTORY AT HOME

Hobbies fretmachines are used in the factories of some of Britain's leading manufacturers—making toys, jigsaw puzzles and novelties, and doing all manner of jobs where intricate cutting is required. They will cut wood, light metals, plastics, leather, card, etc. Taking the same sawblades as used in an ordinary fretwork handframe, a machine doubles the worker's output with half the labour. Many home workers who have discovered the money-making possibilities of a handframe, have further increased their spare-time incomes by investing in a Hobbies machine—some have even made such a machine the foundation of successful businesses. Perhaps a fretmachine would help you, too? Further details are given in Hobbies free booklet (see coupon), and details of all Hobbies tools, kits and materials are contained in the 1955 Handbook.

for only **99/6**

(Carriage pd. U.K.)

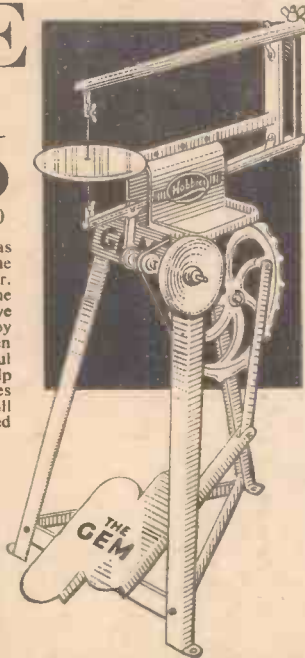

THE GEM FRET MACHINE

is designed for long and trouble-free service. The length of the arms allows work up to 18ins. long (double if that length is cut from both ends) to be manipulated with ease. All steel frame with legs provided with holed lugs for fixing down. Tray for small tools. Supplied ready for use with instruction book and spare sawblades.

Post this coupon NOW!

To: **HOBBIES LTD., Dept. 073, DEREHAM, NORFOLK**

Please send me your free 20-page booklet, and name and address of my nearest stockist. Also supply goods marked thus X.

1955 Handbook 2/3, post free 'Gem' fret machine, 99/6 carriage paid.

NAME

ADDRESS

I enclose P.O. for

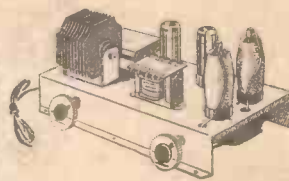

MONEY BACK GUARANTEE **DUKE** Tele: GRA 6677 CWO of COD 621 ROMFORD RD. LONDON, E.12.

T.V. TUBES. 3 MONTHS' GUARANTEE

MAZDA CRM121-A-B, and a few other makes and types. Picture shown to callers, no catch. Not ex-W.D. Carriage and Insurance, 15/6 extra.

SPECIAL OFFER of tubes with burns or cathode to heater shorts. 30/-, plus carr.

AMPLIFIERS.—77/6, push-pull, 4 valve and rec.; full tone range variable. Output 3-7-15 ohms; matching. A.C. or Universal. Post 2/6.

AMPLIFIERS.—57/6. 4 watts, 3 valves. Switched tone range 3-5 ohms. Good quality. A.C. or Universal. Post 2/6.

AMPLIFIERS.—7/6. Ex-W.D., as new, complete with drawings and suggested uses (less valve). Post 1/6.

LADIES ONLY! Treat the lady and yourself to a heated blanket for the home, 37/6 brings a complete heater kit that a lady can fit by herself unaided—with free drawings.

FIRESIDE "RIPPINGILLS" HEATER.—77/6. For the home, works or office. Although these are used ex-W.D. they have all been overhauled and work perfectly (paraffin). Carriage 2/6.

BURGLAR ALARMS.—3/9. Brand new, made by Truvox, in self-contained unit, consists of bell and trip device mounted in metal cover. Works off 4½ volt battery. Post 1/3. Battery for above, 1/6 incl. post. New Ever Ready.

12" T.V. TUBES £5

SPOTLIGHTS.—8/6. Butlers, new ex-W.D., 7½ in. dia., 6½ in. deep. Pre-focus fitting. Post 1/6. Bulbs for these lamps: 6 volt, 36 or 48 watt, and 12 volt, 30, 36 or 48 watt. 4/6 each, post free.

H.T. BATTERIES.—1/9. All-dry + L.T. 1½ volt. min.; 40 volts. 60 volt + 1½ volt All-dry at 3/9. 67½ volt personal portable type at 3/9. 60 volt at 3/9. 90 v. + 1½ volt at 5/9. Post on H.T. batteries 1/9 each.

V.H.F. RECEIVER.—6 valve. 17/6, ex-W.D., new condition; 6-channel switching. Receives T.V. sound, police, fire and amateurs. 30.5 to 40 mc/s.. I.F. 7 mc/s. Post 2/6. Drawings and conversion data for this 1124 set FREE with each set.

NICKEL CHROME WIRE, 2/6 each spool, in tins of .014 at 50 yds., and .032 at 25 yds. Post 6d.

VALVES from 1/9 each.

Catalogue for (2½d.) STAMP ONLY, please.



FREE!

to you!
—if you seek
SUCCESS!

WHAT'S YOUR LINE ?

Agriculture
Architecture
Aircraft Maintenance
Building
Carpentry
Chemistry
Commercial Art
Diesel Engines
Draughtsmanship
Electrical Engineering
Electric Wiring

Engineering Drawings
Fire Engineering
Forestry
Locomotive Engineering
Machine Design
Mechanical
Engineering
Motor Engineering
Plumbing
Power Station Eng.
Quantity Surveying

Accountancy Exams
Auctioneer's Exams
Auditing
Book-keeping
Civil Service
Commercial Arith.
Costing
English
General Education
Geography
Journalism
GENERAL CERT. OF EDUCATION. R.S.A. EXAMS

Languages
Mathematics
Modern Business
Methods
Police Subjects
Salesmanship
Secretarial Exams
Shorthand
Short Story Writing
and many others

Radio Engineering
Road Making
Sanitary Science
Steam Engineering
Surveyor's Exams
Surveying
Telecommunications
Textiles
Wireless Telegraphy
Workshop Practice

TO THE FAMOUS BENNETT COLLEGE

(DEPT. L-76.F), SHEFFIELD

Please send me, without obligation, a free copy of "Train your mind to SUCCESS" and the College Prospectus on:

SUBJECT

NAME

ADDRESS

Please write in Block Letters. AGE (if under 21).....

THIS DAY
COULD BE THE TURNING-
POINT IN YOUR LIFE.
THIS COUPON
COULD BE YOUR PERSONAL
PASSPORT TO SUCCESS.
Send it NOW!



15 good reasons for installing the new—

ZYTO

**MOTORIZED
UNIVERSAL
WOODWORKER**

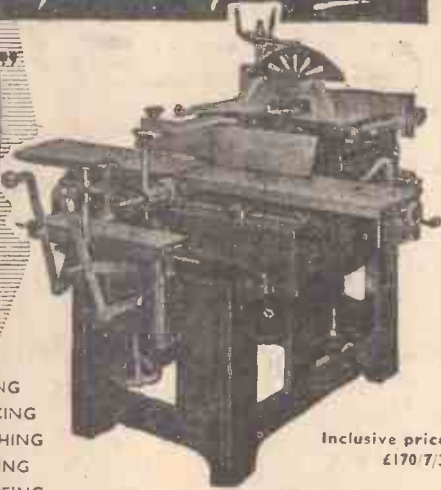

Inclusive price
£170 7/3

- GROOVING ● MITREING
- MOULDING ● SURFACING
- PLANING ● PLOUGHING
- CROSS-CUTTING ● BEVELLING
- TONGUEING
- BORING ● SLOT-MORTICING
- REBATING ● MORTICING
- RIP-SAWING ● CHAMFERING
- SCRIBING

Slot mortice and boring attachment with transverse and longitudinal motion lever feed, and clamping screw to hold work in position.

VEE BELT DRIVE; 3 H.P. MOTOR mounted inside machine on adjustable bracket for belt tension. Complete with necessary pulleys, belts and guards.

Full, illustrated details post free.

* Deferred payments arranged with pleasure
Stock list of machinery free and post free.

The "ZYTO" Universal Woodworker comprises saw table 24" x 18". Takes 15" saw with rise and fall table, long rip fence. Planer, overhand type, 9" cutters; adjustable fence also adapted for rebating.

S. TYZACK & SON, LTD.,
341-345 OLD STREET, LONDON, E.C.1.
Telephones: SHoreditch 8501 (10 lines)

the BURGESS vibro-tool

the ideal engraving tool for the handyman!



YOU will be really amazed by the Vibro-Tool—the power hand-tool that is as easy to handle as a pencil. With it you can write on steel, engrave jewellery, glass and plastics, tool leather, carve wood and cut stencils—and a host of other handicraft and workshop jobs . . . with speed and facility you never dreamed possible.

The V.250 Vibro-Tool complete with standard engraving point.

Operating on the vibratory principle, the Vibro-Tool works off 230/250 volts, 200/220 volts, and 110 volts for A.C. supplies only. Just connect to any electric light socket or plug point.

52/6

97/6

Vibro-Tool De Luxe Kit



Write for Brochure V.T.1 to: BURGESS PRODUCTS Co. LTD. (Vibro-Tool Dept.), HINGLEY, LEICESTERSHIRE.



Real Value



3/7
PER OZ

IT'S A GALLAHER TOBACCO

... it smells as good as it smokes!

E.D. DO IT AGAIN!



EPIC CROSSING OF THE CHANNEL with MODEL PLANE in 40 minutes

On Wednesday, 22nd September, at 1.35 p.m., E.D. Radio Queen took off from the Cliffs of Dover. Forty minutes later, under radio control from an escorting plane, it crossed the French coast—and thus became the first model plane to cross the English Channel.

THIS IS THE ENGINE THAT DID IT!

The famous Radio Queen, which has captured so many competition prizes, was powered by the E.D. 3.46 c.c. Hunter Diesel and fitted with the E.D. Mk. IV Radio Control Unit.

The take-off from Dover Cliffs was under the control of Mr. Sid Allen, who then handed over to Mr. George Honnest-Redlich circling in an Auster Plane.

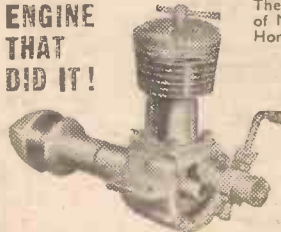

The astonishing success of E.D. enterprises over the past few years have in this latest achievement been proved beyond all doubt. Where reliability is valued and precision workmanship acknowledged, E.D. products have always been the choice of the wiser modelling world.

REMEMBER . . .

E.D. were the first successfully to radio control a model boat across the Channel! Date: 6th September, 1951.

E.D. 3.46 c.c. HUNTER
Price £3.18.5

Water-cooled £5.46

E.D. ALWAYS FIRST!

Write for illustrated list of E.D. Kit Sets, Engines, Radio Controls, etc.
E.D. ELECTRONIC DEVELOPMENTS (SURREY) LTD
DEVELOPMENT ENGINEERS
KINGSTON
4411-2, 18, VILLIERS ROAD, KINGSTON-ON-THAMES, SURREY, ENGLAND.

You MAKE THE BRICKS



TO BUILD THE HOUSE —this simple way:

Just a simple wood mould with a tape or paper strip base—and there's your home-made brickworks, ready to supply you with "Pyruma" bricks for building houses, walls, farm buildings, model railway stations etc. Just one of the ways of modelling in Sankey's "Pyruma" plastic cement explained more fully in the Instruction Book offered below. Other and simpler ways of modelling are also described, showing how to make many useful, permanent stone-hard objects which can be painted in colour, from



Pyruma is ready for use from its airtight tin—to be modelled while plastic. It dries or bakes to stone hardness and, after treatment as instructed, can then be painted or enamelled.

Pyruma is ideal for modelling Houses, Railway and Airport Buildings, Farms, Docks, Figures and for making Ashtrays, Bookends, Plaques, Dolls Furniture, Relief Maps, Animals, etc.

Sankey's PYRUMA and TILUMA are inexpensive and obtainable in air-tight tins from Ironmongers, Art Material Dealers, Hobbies Shops, etc.



POST THE COUPON TO-DAY

To: **J.H. SANKEY & SON LTD** (Dept. P.M.)
 ILFORD, ESSEX

Enclosed 4d. in stamps for PYRUMA MODELLING INSTRUCTION BOOK addressed to:

NAME (Block letters)

ADDRESS

MIDLAND INSTRUMENT CO. OFFER:—

SELSYN TRANSMITTERS (Magslips), 3in. type, pure synchro. x-y-1-2-3, suitable as master or slave, 50 v. 50-cycle single phase A.C. operated. When two or more of these are wired up, the rotation by hand (or other means) of one will result in a 100 per cent. follow in the other(s), both clockwise or anti-clockwise, supplied brand new with test report, in tropicalised sealed cartons, value 48 each; our price 25/-, post 2/-; 2 for 50/-, post paid, with wiring diagram. **SIEMENS HIGH SPEED RELAYS**, coil res. 145 ohms, single-pole changeover platinum contacts, adjustable armature tension and contact gap, well worth 35/-, our price, new, unused, 5/-, post 6d.; 50/- doz., post 2/-.

ELECTRO-MAGNETIC COUNTERS, 0-9999 repeating, 3-ohm coil, operates down to 1 1/2 v., size 1 1/2 in. x 1 1/2 in. x 4 1/2 in. long, perfect order, 5/-, post 1/-.

PROJECTION UNITS, consists of an optical mount fitted with a bloomed F.2.2 Achromatic lens, 3 1/2 in. focal length at one end, and a concave/convex ground glass at the other, attached to an enclosed lamphouse fitted with a 24 v. 15-watt lamp, with polished reflector, fraction of original cost, 10/-, post 1/-.

VENNER AUTO TIME DELAY SWITCHES, 12/24 v. operation, consists of a high-grade clockwork mechanism, with external wind, 2 electro-magnets with cam-operated contacts, in smart metal cases, fitted 4-way terminal block size 3 1/2 in. x 2 1/2 in. x 2 1/2 in., new, boxed, cost 4s., our price 7/6, post 1/3.

HOOVER BLOWER MOTORS, dual voltage, with terminations for 12 or 24 v. D.C., alternatively 20 or 40 v. A.C., length 5 1/2 in., blower casing 4 1/2 in. dia., 1 1/2 in. dia. inlet and outlet ports, thousands of these have been fitted for car heaters, new, unused, complete with 2 hose connectors, 25/-, post 1/6.

TELEPHONE SETS, consists of 2 combined receivers and microphones, connected by 20ft. twin flexible, provides perfect 2-way communication, (up to 1 mile with extra flex), self-generated, no battery required, complete ready for use, new, boxed, 12/8, post 1/-.

4 1/2" TYPE CYLINDER LOCKS, deadlocking and thiefproof, has 7 concentric tumblers instead of the usual 5 in line, interchangeable with ordinary cylinder locks, for right-or-left-hand doors, complete with 2 keys and all fittings, instruction booklet, list price 18/9, our price, new, boxed, 5/-, post 1/3; 2 for 10/-, post paid.

LIGHTER PARTS, cartons of 60 brand new parts, includes fine cut wheels, springs, stems, frames, bearings, etc., enough parts to nearly complete 2 high-grade lighters, easily worth 15/-, our price, 2/8, post 4d.

D.C. SERIES MOTORS, 12-24 v. 15/20 amps., size 6 1/2 in. long, 3 1/2 in. dia., fitted 1/2 in. dia. shaft, weight 9 lbs., a very superior motor, originally cost £10, our price, new, unused, 7/6, post and packing 2/6.

SPIRIT DUPLICATING CARBONS, size 16 1/2 in. x 13 in., cartons of 100 sheets, tissue interleaved, worth 15/-, our price, brand new, 2/6, post 1/8.

T.R.S. FLEXIBLE CABLE, twin 16/02 circular rubber covered, 250 v. insulation, at approx. one-third to-day's price; 25 yds., 15/-, post 1/8; 50 yds., 27/8, post 2/-; 100 yds., 50/-, carriage 5/-.

WIRE STRIPPERS, strips the insulation from flexes and cables up to 1/4 in. dia., micrometer adjustment, brand new, boxed, usual toolshop price, 15/-, our price, 3/6, post 6d.; 3 for 10/-, post paid.

BURGESS MICRO SWITCHES, make or break, size 2 1/2 in. x 1 1/2 in. x 1 1/2 in., many applications, new, unused, 1/8, post 3d.; 18/- doz., post 1/-.

BZZERS, 3-6 v. high note, platinum contacts, variable note control knob, very high grade type, worth 40/-, our price, new, unused, 5/-, post 1/-.

AIR COMPRESSORS, Romec rotary vane, develops 20/30 lbs. sq. in., size 6 1/2 in. long, 4 1/2 in. x 4 1/2 in. dia., brand new in sealed cartons, 20/-, post 2/-.

BRASS CUT THREAD SCREWS, 4-8-8-10-12-B.A., cheese, countersunk, round and hex. heads, 2-gross assort, 5/-, post 6d.

PLESSEY P.M. SPEAKERS, 3in. dia., personal portable type, 3-ohm speech coil, less transformer, brand new, 7/6, post 9d.

CHARGING KITS, consists of a G.E.C. 11-amp. full-wave rectifier and a Douglas 200/250 v. A.C. input transformer, specially wound for this rectifier, with requisite voltages to charge a 2-, 6- or 12-v. battery at 1 amp., 2 high grade components, complete with circuit diagram and instructions, 25/-, post 1/8.

ELECTRIC BELLS, 12 v. D.C. operation, 3in. dia., 1 1/2 in. high, single dome, very superior, worth 20/-, our price, brand new, boxed, 3/6, post 9d.

Also hundreds of other interesting items. Send 3d. with s.a.p. for current lists.

MIDLAND INSTRUMENT CO.,
 Moorpool Circle, Birmingham, 17. Tel. HAR 1308



SCIENTIFIC STUDENTS, KEEN PHOTOGRAPHERS &

anyone needing a good reliable Balance at a really

REASONABLE PRICE

should secure a "COURIER" Precision Balance Outfit (Pat. App. for) with which to build for themselves this Balance from genuine commercial balance parts, including real AGATE bearings, steel knives, brass pans and fittings.

Capacity: 100 grm. Sensitivity: 10 mgrm.

These outfits are designed and produced by Balance specialists. Complete, with full instructions and blueprint. From your usual supplier or direct.

WILLIAM A. WEBB LTD. (DEPT. C)
 1-9, Perryman's Farm Road, ILFORD, ESSEX, ENG. **Price 47/6**
 (UK postage 1/-)

THE IDEAL XMAS GIFT

For the close scrutiny of fractures or defects on surfaces, cutting edges, faults in tools, cracks in castings, the Ultra Lens is invaluable. Revealing every detail with startling exactness, highly magnified and brilliantly illuminated in natural colourings, it presents in many instances hitherto unsuspected data which can be used to advantage. Price £5.15.0 complete in cardboard case with spare bulb, battery and transparent measuring scale. Packed in luxury velvet lined case. 10/- extra. Postage and Packing 1/6.

The Ultra Lens is an illuminated magnifier. It is a revealing eye of six actual diametrical magnifications. When your friends and colleagues are seeking a really worthwhile and useful Xmas Gift, suggest to them the **ULTRA LENS**. There is no finer gift for an engineer, or anyone engaged in mechanics either for a living or as a hobby.

Actual Size 63/4 x 1 5/8

BRITISH MADE

Full particulars on request.

THE ULTRA LENS COMPANY, Tel.: TRAFalgar 2055
 17c, Oxendon Street, London, S.W.1

12-18 or 24 months to pay for your MYFORD . . .

STREAMLINED SERVICE. IMMEDIATE DESPATCH FROM STOCK.

OUR OUT OF INCOME TERMS OFFER YOU A SOUND COMMON SENSE METHOD OF INCREASING YOUR WORKSHOP EFFICIENCY. NO FUSS—NO BOTHER.

MYFORD M.L.7. BENCH LATHE with standard equipment, £43.5.0. Deposit £12.1.7 and 12 monthly payments of 65/5d. Deposit £12.1.6 and 18 monthly payments of 45/5d. Deposit £12.2.1 and 24 monthly payments of 35/3d.

MYFORD SUPER 7 BENCH LATHE with standard equipment, £73.5.0. Deposit £18.6.5 and 12 monthly payments of 99/4d. Deposit £18.7.4 and 18 monthly payments of 68/11d. Deposit £18.7.10 and 24 monthly payments of 53/6d.

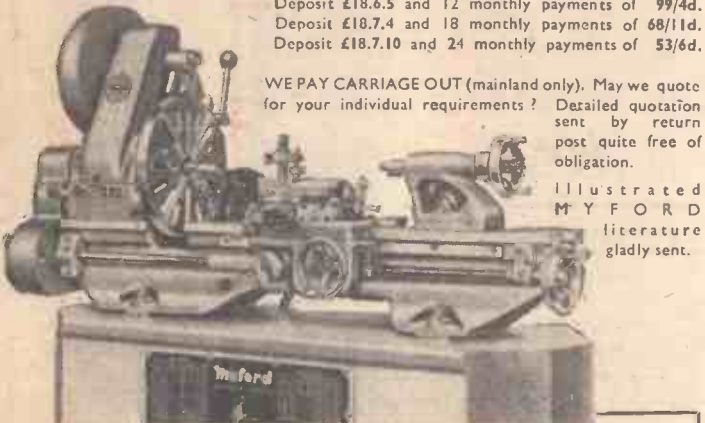

WE PAY CARRIAGE OUT (mainland only). May we quote for your individual requirements? Detailed quotation sent by return post quite free of obligation.

Illustrated MYFORD literature gladly sent.

"THE CHOICE OF EXPERIENCE"

A. J. REEVES & CO.

416, MOSELEY ROAD, BIRMINGHAM, 12
Grams: "Reevesco, Birmingham." Phone: CALthorpe 2554.

Plastics LTD (MANCHESTER)

BRITAIN'S LEADING STOCKISTS OF

"PERSPEX" SHEET - ROD - TUBE

11 WHITWORTH STREET · MANCHESTER, 1
Telephones: CENTral 7081-2 and 1000

EX-ADMIRALTY TELESCOPES. Highest quality single-draw Telescopes by Ross of London and Ottway of Ealing. 16 x 42mm. Length 16in. Weight 24lbs. Optically good—externally fair. Originally cost about £12.

Post free 65/-

3in. ADMIRALTY COAST GUARD TELESCOPES. Suitable for Astronomical and Terrestrial use. Magnification 40X. Length 37in. Optically good. Complete with rigid garden tripod. Estimated original cost about £50. Price £10.15.0 to £14.10.0 according to external condition. Part carriage 5/- extra.

EX-AIR MINISTRY PRISM BINOCULARS. 6 x 30. Good used condition. Eyepiece focusing, with leather case. Post free £8.5.0

NEW 8 x 30 CENTRE FOCUSING PRISM BINOCULARS. Coated. With leather case. Post free £12.10.0

NEW 12 x 40 CENTRE FOCUSING PRISM BINOCULARS. Coated. With leather case. Post free £15.10.0

We guarantee satisfaction or full refund. Illustrated Brochure on request.

CHARLES FRANK
67-73, SALTMARKET, GLASGOW. C.I.
Phone: Bell 2106-7.

AC/DC THREE

A remarkable bargain—totally self-contained powerful receiver for long and medium waves—all parts including valves, coils, resistors, etc., but not loudspeaker and cabinet will cost you only 19/6. post, etc. 1/6—data available separately, 2/- post free.

"CHIMELITE"

It is a hall light as well as a double chime and you can make it in a couple of evenings for the total cost of only 19/6 including instructions, post, etc., 2/-—data available separately price 2/-.

19/6 22/6 FLUORESCENT LIGHTING

Kit comprises 40 watt control unit, starter lamp, lamp holders, clips and wiring diagram. Price, less tube, 22/6, plus 1/6 post. With tube, 30/-, plus 3/6 carriage.

CLEVELAND CAR BATTERY CHARGER

gives 11 amps. charge—uses everlasting metal rectifier and robust double-wound mains transformer—in metal carrying case with leads and croc. clips. Price 6 volts 29/6; 6 or 12 volts, 39/6. Post 2/6.

EVERLASTING GRAMOPHONE NEEDLES

Jewel (Sapphire) pointed, suit any type of pick-up, precision made—improves quality, eliminates record wear. 3 types, loud, soft, trailer, 2/6 each.



BLACK & DECKER ELECTRIC TOOLS

14 DAYS' FREE TRIAL

Send only £1 deposit—refunded if tool not approved.

1in. DRILL

Robust tool with trigger switch and self-centring chuck. Drills, sands, polishes, grinds, sharpens. Also, with attachments, drives: lathe, saw bench, rise and fall, grinder, buffer, etc. Price £5.19.6 cash, or 20/- deposit. Carriage and Packing 2/6.

Horizontal Stand

17/6, post 1/6.

Vertical Bench Stand

£3.7.6, post 2/6.

Lathe Stand

£5.5.0, or 20/- deposit. Carriage and Packing 5/-.

The four items £15.9.6, or £3 deposit.



MAKE IT YOURSELF AND SO SAVE 25-30%

All parts assemble perfectly into professional portable cabinet—send for constructional booklet to-day, price 2/-.



INFRAY LAMP

Means real comfort in bed as it emits Infra Red Rays which warm and keep you healthy.

● Economical. ● Costs only 1d. per hour (electricity at 1d. per unit). ● Absolutely safe, no health or fire risk. ● Ideal for many other uses—over pet's basket, rearing pup, chicks, over desk, work bench, etc. ● All complete and ready to work.



Price 36/- Post & Packing 2/-



BE PREPARED for a cold winter by making our low cost Electric Blanket. 27 yards of special heater wire and blueprint, 20/- Blueprint only 1/6. Alternatively make a Bed Warmer. Constructional data 1/6.

MULTI-METER KIT

The Multi-meter illustrated measures D.C. volts, D.C. m/amps and ohms. It has a sensitivity of 200 ohms per volt and is equally suitable for the keen experimenter, service engineer or student. All the essential parts including 2in. moving coil meter, selected resistors, wire for shunts, 8-point range selector, calibrated scale, stick-on range indicator and full instructions for making are available as a kit, price 15/-, plus 9d. post and packing.



ft. long made from heavy gauge sheet steel (galvanised), 1 kW, suitable A.C. or D.C. Price £2, or with thermostat £3.15.0. Note: The thermostat mounts separately and will control up to three heaters.

ELECTRIC CLOTHES HORSE

Warms room as it dries clothes, towels, etc.—A.C. or D.C. 650 watts. Size 3ft. x 3ft. x 5in. Made to sell at 12 gns., fully guaranteed only £3.19.6. carr. 7/6.



CABINET 19/6

You can make an excellent bass reflex cabinet with this well-made veneered and polished walnut cabinet. Limited quantity offered at 19/6, carriage, etc. 3/6.



MAKE A RADIO

Using our parts in one evening you can make an all mains 4 valve radio with bakelite case, then you will be giving a £12 present which costs you only £5.15.0, or £2 deposit. (Carr. and insurance 5/-) Data book 1/6.



ELECTRONIC PRECISION EQUIPMENT, Ltd.

Post Orders should be addressed to: DEPT. 1, RUISLIP, MIDDLESEX.

Personal shoppers, however, should call at any of our following branches: 42/46, WINDMILL HILL 29, STROUD GREEN 152/153, FLEET STREET RUISLIP, MIDDX. ● ROAD, FINSBURY ● LONDON, E.C.4. PARK

Phone: Ruislip 5780 and 249, KILBURN HIGH ROAD, KILBURN, LONDON, N.W.

Phone: Archway 1049

Phone: Central 2833

VALUABLE NEW HANDBOOK FREE TO AMBITIOUS ENGINEERS

Have you had your copy of "Engineering Opportunities"?

The new edition of "ENGINEERING OPPORTUNITIES" is now available—without charge—to all who are anxious for a worthwhile post in Engineering. Frank, informative and completely up to date, the new "ENGINEERING OPPORTUNITIES" should be in the hands of every person engaged in any branch of the Engineering industry, irrespective of age, experience or training.

**We definitely Guarantee
"NO PASS—NO FEE"**

This remarkable book gives details of examinations and courses in every branch of Engineering, Building, etc., outlines the openings available and the essential requirements to quick promotion and describes the advantages of our Special Appointments Department.

WHICH OF THESE IS YOUR PET SUBJECT?

MECHANICAL ENGINEERING
Gen. Mech. Eng.—Maintenance — Draughtsmanship—Heavy Diesel—Die & Press Tool Work—Welding—Production Eng.—Jig & Tool Design—Sheet Metal Work—Works Management — Mining — Refrigeration—Metallurgy.

ELECTRICAL ENGINEERING
Gen. Elec. Eng.—Elementary & Advanced Elec. Technology—Installations Draughtsmanship—Supply —Maintenance — Design —Electrical Traction —Mining Electrical Eng.—Power Station Equipment, etc.

RADIO ENGINEERING
Gen. Radio Eng.—Radio Servicing, Maintenance & Repairs—Sound Film Projection — Telegraphy — Telephony — Television — C. & G. Telecommunications.

AUTOMOBILE ENGINEERING
Gen. Automobile Eng.—Motor Maintenance & Repairs — High Speed Diesel—Garage Management.

CIVIL ENGINEERING
Gen. Civil Eng.—Sanitary Eng.—Structural Eng.—Road Eng. — Reinforced Concrete—Geology.

BUILDING
Gen. Building—Heating & Ventilation—Architectural Draughtsmanship — Surveying — Clerk of Works — Carpentry and Joinery —Quantities — Valuations

WE HAVE A WIDE RANGE OF AERONAUTICAL COURSES AND COURSES IN FORESTRY, TIMBER TECHNOLOGY, PLASTICS, G.P.O. ENG., TEXTILE TECHNOLOGY, ETC., ETC.

One of these qualifications would increase your earning power
WHICH ONE?

A.M.I.Mech.E., A.M.I.C.E., A.M.I.P.E., B.Sc., A.M.Brit.I.R.E., A.F.R.Ae.S., A.M.I.M.I., L.I.O.B., A.R.I.B.A., A.M.I.H. & V.E., M.R.San.I., F.R.I.C.S., A.M.I.E.D., CITY & GUILDS, COMMON PRELIM., GEN. CERT. OF EDUCATION, ETC.

THE BRITISH INSTITUTE OF ENGINEERING TECHNOLOGY



410A, COLLEGE HOUSE,
29-31, WRIGHT'S LANE,
KENSINGTON, W.8.

Phone: WEStern 9861

WHAT THIS BOOK TELLS YOU

- ★ HOW to get a better paid, more interesting job.
- ★ HOW to qualify for rapid promotion.
- ★ HOW to put some valuable letters after your name and become a "key-man" . . . quickly and easily.
- ★ HOW to benefit from our free Advisory and Appointments Depts.
- ★ WHERE today's real opportunities are . . . and HOW you can take advantage of the chances you are now missing.
- ★ HOW, irrespective of your age, education or experience, YOU can succeed in any branch of Engineering that appeals to you.

144 PAGES OF EXPERT CAREER-GUIDANCE

You are bound to benefit from reading "ENGINEERING OPPORTUNITIES," and if you are earning less than £15 a week you should send for your copy of this enlightening book **now**—FREE and without obligation.



POST NOW!

TO: B.I.E.T. 410A, COLLEGE HOUSE, 29-31, WRIGHT'S LANE, KENSINGTON, W.8.

Please send me FREE and without obligation, a copy of "ENGINEERING OPPORTUNITIES." I am interested in (state subject, exam., or career).....

NAME

ADDRESS

WRITE IF YOU PREFER NOT TO CUT THIS PAGE

Only 1d. stamp is needed if posted in an unsealed envelope.



PRACTICAL MECHANICS



The "Cyclist," and "Home Movies" are temporarily incorporated.

VOL. XXII. No. 252

Editor: F. J. CAMM

DECEMBER, 1954

Another Visitor from Space

FROM recent official announcements it is clear that something strange is happening in the air. Weird formations have been reported on the radar screens of official observatories throughout the world, and their existence cannot be accounted for by any of the known causes. Investigation on an official and world-wide basis is now in progress, and we may hope that as a result the mystery of these frequent reported sightings of space craft will be solved, if only partly.

Many of these reports can be discounted as hoaxes, science fiction, and as mistaken identification of experimental craft. It would be absurd, however, to suggest that all reports can be explained away on the grounds that they are caused by well-known phenomena. It is strange that none of our readers, a high percentage of whom have scientific knowledge, has ever reported to me that they have seen a spaceship. Indeed, the bulk of the very heavy correspondence we receive on the subject severely criticises existing literature and pours scorn on the claims made.

This journal has, I believe, published more information about space craft and the possibilities of interplanetary travel than any other English journal; for I believe it to be possible, practicable and that it will be achieved some time during the present century. It must not be inferred from this that I believe all of the claims which have been made, nor that I accept evidence that spaceships have landed. I do not, of course, impugn the integrity of any author who claims to have seen a spaceship and to have interviewed its occupants. Mistakes can be made. If one believes in spaceships one is likely to conclude on flimsy evidence that a particular craft with a foreign pilot who cannot speak English has arrived from another planet. It does not seem to have occurred to anyone that the proper thing to do with an invader is to have him placed under arrest until he has proved his peaceful motives. If an aeroplane from a foreign country made an unofficial landing in this country it would certainly be impounded until satisfactory explanations had been made. There appears to be no evidence of a

FAIR COMMENT

By

The Editor

flying saucer having crashed—and this seems almost incredible in these early days, for it is stretching human credulity a little too far to expect us to believe that the Martians and the Venusians have achieved perfection in interplanetary travel. Their arrival here also seems to be objectless. We are told that they are endeavouring to help us in our present difficulties and that they are concerned that we may start an atomic war. We are not told how they have come into possession of the information that we have in recent years been involved in war. The sporadic arrival of a spaceship in any case is hardly likely to achieve such an object.

Elsewhere in this issue I have reviewed the latest book on the subject written by one who not only claims to have interviewed a Martian but to have photographed him, and I reproduce a print from the author's negative. All these reports show the authors to be poor photographers and the very murkiness of their photographs is, perhaps, the cause of much of the doubt expressed. None of them has photographed a spaceman emerging or re-entering his ship. The latter are always photographed without any recognisable background of hills, land or trees. Perhaps now that official attention is being given to the matter all over the world, something more tangible may result.

Two Anniversaries

TWO interesting anniversaries have just occurred. The Interplanetary Society, which is very much concerned with space travel, celebrated its twenty-first anniversary on October 6th, 1954. The Society was founded at Liverpool in October, 1933, by Philip E. Cleator, who has written many books on the subject of interplanetary travel. The objects of the Society are the furtherance of all studies leading to the development of space travel to the moon and other heavenly bodies. These studies embrace almost every branch of science, for all branches have some bearing on this new science of astronautics. Like all new societies, it was the object of derision and scorn in its early days and especially by scientists who expressed the view that the rocket would never be more than a toy. Its original membership was about 30, whereas to-day it is 2,700, including some of the world's leading rocket engineers, astronomers and guided-missile experts. It now publishes its own scientific journal and it organised the second International Astronautical Congress.

The second anniversary is the Jubilee of the invention of the thermionic valve, for it was on November 16th, 1904, that Mr. (later Sir) Ambrose Fleming filed his patent application. The rectifying properties of the valve were known from the previous work of Edison, and J. J. Thomson had already identified the electron which carries the current. Richardson had published his formula for electronic emission. In 1904, Wehnelt patented a rectifier embodying the oxide-coated cathode which was later to assume great importance. It was Fleming, however, who perfected the thermionic valve and laid the foundation stone of the growing science of electronics which daily permeates life.

Space-travel would be impossible without electronics and so would radio and television, computing machines, and many other devices. It is true to say that Fleming never obtained real recognition of his great work, being overshadowed by the publicity given to Marconi and his experiments. It is unlikely, however, that Fleming realised where his invention would lead.—F. J. C.

SUBSCRIPTION RATES

including postage for one year

Inland - - - - 14s. per annum.
Abroad - - - - 14s. per annum.

Editorial and Advertisement Office: "Practical Mechanics," George Newnes, Ltd., Tower House, Southampton Street, Strand, W.C.2
Phone: Temple Bar 4363
Telegrams: Newnes, Rand, London.

Copyright in all drawings, photographs and articles published in "Practical Mechanics" is specially reserved throughout the countries signatory to the Berne Convention and the U.S.A. Reproductions or imitations of any of these are therefore expressly forbidden.

THESE tricks are of a type which anyone can master quickly, for performance at Christmas parties. The various articles required are such as can be found about the home; no sleight of hand is involved and only quite simple preparations are needed.



The Magic Matches

You begin by showing an ordinary box of matches. You empty out all the matches and place the box in full view on your table. The matches you

the empty matchbox and bring out the elastic band. This you now keep concealed.

Now to vanish the matches. Throw the handkerchief over your hand, spreading the elastic band between the tips of your fingers and thumb as shown in Fig. 2. Pick up the matches a few at a time and push them down into the centre of the handkerchief. As soon as they are all in the handkerchief, bend your fingers and thumb and allow the elastic band to snap round the handkerchief, just above the bundle of matches (see Fig. 3). The matches are now held firmly in an impromptu secret pocket in the handkerchief. You can take a corner of the handkerchief and flick it

You show a long piece of tape and taking it by the centre you cut several pieces from it. The pieces are really cut and can be seen to fall to the ground.

After this you explain that, by using the handles of the scissors instead of the blades, you can produce the reverse effect. That is to say you will make the tape become joined together again without having to sew it. You snip about with the handle ends of the scissors, draw out the tape from your hand and it is in one single piece again with no trace of any join.

How it is done. Use a good wide piece of tape or braid about three yards long. Cut

CHRISTMAS



Some Effective Tricks that Do Not Require Skill or Special Apparatus

By "MAGICIAN"

MAGIC

then proceed to wrap in the folds of a large handkerchief.

"Matches have a way of disappearing very quickly, as most housewives know," you remark, then flicking the handkerchief in the air you show that these matches have disappeared even more quickly than usual. You then pick up the box, open it and tip out the matches which have seemingly returned mysteriously to the box.

How it is done. On your table is a large handkerchief and concealed beneath its folds at the back, is a box full of matches. In your pocket you have a small but strong elastic band.

You show a box of matches of the same brand as the concealed box and tip all the matches out neatly on the table. Let the audience see that the box really is empty, then close it. Fig. 1 shows what you do next.

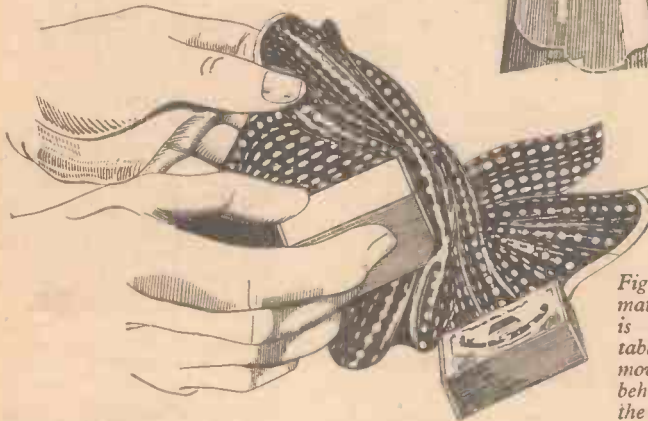
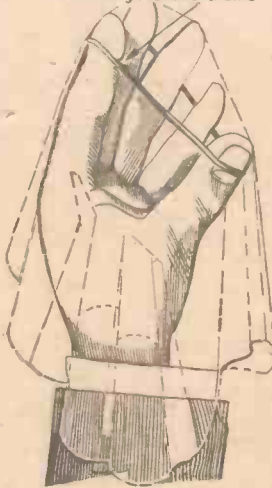

Fig. 1 (Left).—Changing a matchbox. The box in the hand is apparently placed on the table and the handkerchief removed. Actually it is removed behind the handkerchief and the box on the table is revealed.

To the audience you appear simply to put the empty matchbox on the table and pick up the handkerchief. What you really do is to put the box down behind the handkerchief, pick it up again without letting go of it, and at the same time pick up the handkerchief with your other hand and throw it over the hand holding the matchbox. As you move away from the table the other box is revealed on the table and this is taken to be the empty one.

Under cover of the folds of the handkerchief you then conceal the box in your partly closed hand, then, while talking about the matches, casually put your hand in your pocket and take it out again. This is a perfectly natural action but enables you to leave behind

Rubber band stretched over fingers and thumb



Pouch formed in centre of handkerchief

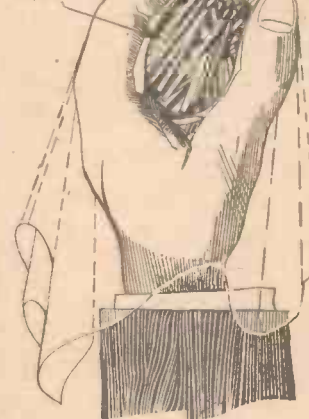

Rubber band retains matches in pouch

Fig. 2 (Top left).—How the elastic band is held underneath the handkerchief. Fig. 3 (Top right).—Matches pushed down into handkerchief and elastic band allowed to snap round, enclosing them in a bag.

into the air. The matches seem to have disappeared for, if the handkerchief is a good one, the presence of the bundle of matches is entirely concealed by the folds. You finish the trick by opening the box and pouring out the matches.

Saving the Stitches

Now for a very puzzling but quite easy trick with some tape or braid.

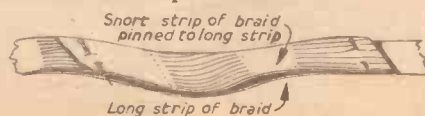

Fig. 4.—How the tape is faked.

about 7in. from one end and pin it to the centre of the long piece as shown in Fig. 4. If you do this neatly you can hold the braid up with the unprepared side towards the audience and it appears to be a quite ordinary piece of braid.

Now take the braid by the centre and draw through your closed hand. As you do this you pull out at the top of your hand the centre of the short piece, leaving the centre of the long piece hanging down out of sight; reference to Fig. 5 will make this quite clear. You now cut the braid. You cut it several times. In fact, you cut away all the small piece and by pretending to adjust the ends you pull out the pins and let them drop with the short ends. To the audience it appears that the braid is now



Fig. 5.—Restoring a cut tape. The sketch shows how the extra short piece pinned to the long piece of tape is cut away, leaving the long piece intact.

definitely cut into at least two long pieces. Actually, of course, the long piece of braid is unharmed and, after a little by-play with the scissors, it is drawn out and shown to be whole.

Call Up Your Card

This is probably the most popular of all card tricks. Three cards having been chosen and returned to the pack, the pack is then placed in a glass. The chosen cards are called for one by one and they mysteriously rise from the centre of the pack.

How it is done. There are several hundred

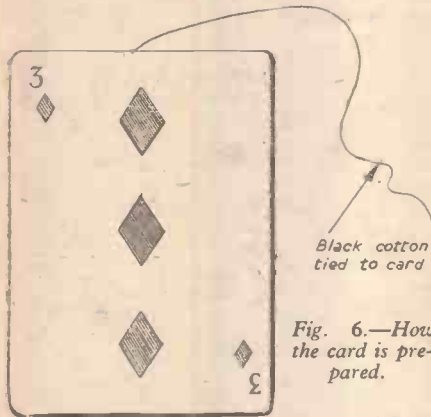

Fig. 6.—How the card is prepared.

different ways of doing this particular trick. Some of them need very expensive apparatus, and a good many call for a moderate amount of skill. Here is a simple method.

Prepare one card, any card you like, by tying one end of a piece of fine black cotton to it as shown in Fig. 6. Place this card face downwards on your table and lay a handkerchief loosely over it. Measure off a piece of thread, the exact length you must work out yourself when you prepare the trick. Tie a pin or a needle to the free end of it and stick the needle in the tablecloth near the back edge.

That is all the preparation needed. The rest is all in the way it is done.

Start by handing out a pack of cards to be shuffled and have three cards chosen. Do not have the cards replaced but lay the pack face down on the table immediately on top of the prepared card. To do this you must, of course, pick up the handkerchief, and this action hides the fact that you are putting the pack on an extra card. Now use the handkerchief to polish the glass. This gives an excuse for its presence. Pick up the pack and drop it into the glass. The extra card will be facing the audience and you secretly arrange the cotton across the top of the pack from front to back.

The next thing to do is to take the chosen cards and push them down into the pack. Each card goes behind the one just inserted, and each card carries down with it some of the cotton. You must keep your fingers on top of the cards to prevent those first pushed down from coming up when the others are inserted.

You are now ready for the magical appearance of the cards. Have them named, remembering that the last card you pushed into the pack will be the first to appear.

Hold the glass in your hand and gradually move it forward until the cotton is pulled tight. As you continue this gradual and imperceptible forward movement of the glass, the last card inserted will gradually rise out of the pack. When it has risen about half-way take it out and have the next card called, making this rise in the same way. If you



Fig. 7.—The rising card trick ready to be performed. The cotton goes down behind the card and up in front of it.

black cotton, as this will be invisible at a moderate distance.

Stabbing the Card

You have a card chosen and returned to the pack which you spread on the table, face downwards or permit some member of the audience to do so. You obviously cannot know where the chosen card is and to make the

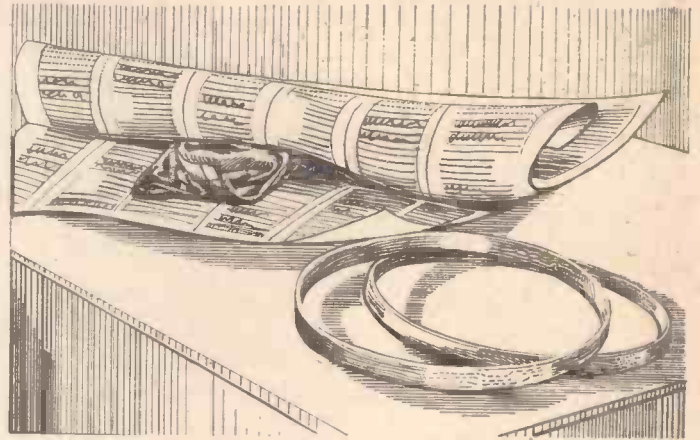

Fig. 10.—Silk handkerchiefs from a tambourine. How the silks are concealed between a double thickness of paper, the edges of which are pasted together.

trick seem more difficult you spread a newspaper over the cards. Then, taking a pen-knife, you stab through the paper, drag the knife out to the edge and lift it when the audience see that you have somehow managed to stab the very card that was chosen.

How it is Done. Covering the cards with newspaper to make the trick seem more difficult actually makes it possible to do it quite easily. If you look at Fig. 8, you will see that the card which is stabbed is not one of those on the table at all but another card which has been hidden in a pocket in the newspaper. Fig. 9 shows how the card is

Pocket of newspaper pasted on round edges



Card concealed in pocket face to newspaper and back towards pocket

Folded silk handkerchiefs concealed between double sheets of newspaper



Paste papers together here and here all round edges

Figs. 9 and 11 (Above).—The concealed pocket in the newspaper containing a card, and to the right, a handkerchief hidden by the same method. **Fig. 8 (Left).**—Stabbing a card. The duplicate card being dragged from its pocket in the newspaper.

concealed. Cut a piece of newspaper about 1in. larger all round the card, put the card face down on the paper and paste the small piece of paper over it. Pasting the edges only.

When you lay the paper over the cards you do so with the pocket underneath. It is a simple matter to locate the card in the pocket, then you stab the knife well and truly through paper and card, lift the paper slightly and drag the knife through the paper out to the edge, bringing the card with it.

Of course, this means that you have got to be certain in advance that the person choosing the card will take the one of which the hidden card is a duplicate. An easy way to arrange this is as follows. Have the required card on top of the pack and ask someone to call out for a small number. Supposing five is asked

how it causes the cards to rise. Needless to say you use

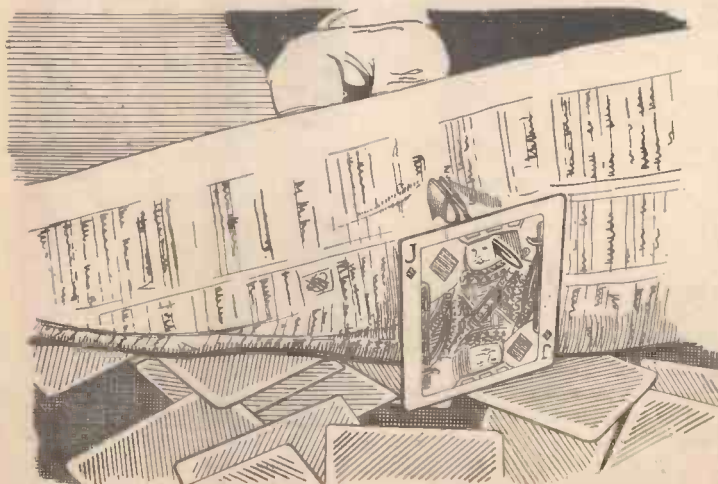

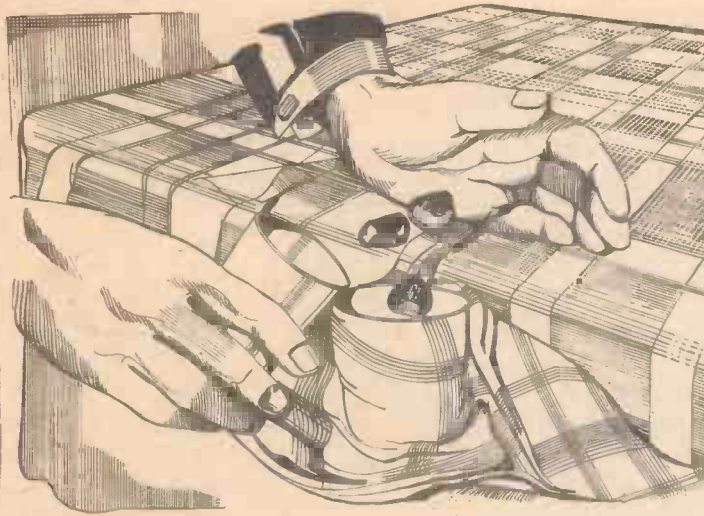

Fig. 12.—Vanishing chestnuts. The nuts being scooped into the goblet, falling actually into a second goblet pinned to the back of the table cloth (view as seen from behind.)

for. Proceed to count five cards off the top of the pack, starting with the top one and sliding each successive one on top of the one preceding it. Stop at the fifth and hold up the small packet. The original top card will be at the bottom of the pack facing the audience who will not realise that this is the first card counted but take it for the fifth. Of course your card in the newspaper is a duplicate of this card.

Talking of things hidden in sheets of news-

paper reminds me of a good way of producing silk handkerchiefs or flags.

The Tricky Tambourine

The tambourine is made by pressing a pair of wooden embroidery hoops on either side of a sheet of newspaper and trimming off the edges. To the audience there appears to be no room for concealment of any article, yet you instantly break the paper in the very centre of the tambourine and draw out several coloured silk handkerchiefs.

How it is Done.

The handkerchiefs, folded small and pressed flat, are concealed between two sheets of paper as shown in Figs. 10 and 11. If you like you can use ribbon instead of handkerchiefs. In that case fold the ribbon in pleats, first one way then the other zig zag fashion and it will draw out of the paper easily.

Hold up the sheet of paper and show it casually, then place it between the wooden hoops, trim off surplus, break a hole in the

centre and produce the silks. It helps the effect if you have a whole newspaper on the table and take an odd sheet out for the trick. Of course, the odd sheet is the one you have prepared.

Flying Chestnuts

You throw a few chestnuts on the table and drop a piece of string into a hat. You then scoop the nuts into a goblet and make a throwing movement towards the hat. The chestnuts vanish and are found in the hat, neatly threaded on string.

How it is Done. The string of chestnuts is already in the hat. You show another piece of string and just toss it into the hat. There is no need to show the hat empty as it does not appear to play an important part in the trick. At the end of the effect you then have only to pick out the string of chestnuts to complete the trick. Vanishing the nuts is accomplished by having a second goblet in a secret pocket at the back of the table, made by pinning the cloth round the goblet. Pour the nuts onto the table and scoop them into the goblet off the back of the table. Throw them out onto the table again. This gets the audience used to the idea of the nuts being really scooped into the goblet. Next time you do the scooping in, you let the nuts fall into the hidden goblet as shown in Fig. 12 and bring up the visible goblet empty. To make the nuts vanish you have only to make a throwing movement with the already empty goblet. Performed briskly this is a most astonishing little trick.

One final piece of advice. Try each trick out before you attempt to perform it to an audience and have a good stock of little jokes to make while you are showing the effects.

A Christmas Tree Support

Ensuring that Your Tree Does Not Get Upset



Fig. 1.—The completed tree support.

the two hinges are fixed for the hanging one half of the lid as indicated in Fig. 2. The strip is cut from a piece of wood 1in. wide and fixed to the top of one of the sides between the corner posts with two or three small

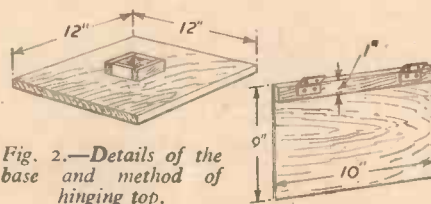

Fig. 2.—Details of the base and method of hinging top.

screws. Cut off four pieces of corner moulding with 3/16in. groove and glue the four sides into it. The completed sides are next fixed in a central position on the base with glue, and in order to provide an extra support four pieces of 1/4in. triangular blocking fillets about 4in. long are glued along the bottom corners where the sides join the base.

The lid for the box is formed in two halves and cut from oak 1/4in. thick, 11in. by 5 1/2in. A semi-circle in the middle of one edge of each half of the lid is cut to fit the trunk of the tree. One half is glued on the top of the box and the other half is hinged to the side. Four 3/4in. ball feet are fixed one at each corner of the base.

IN order to avoid an accident during the progress of the Christmas party, it is as well to pay a little attention to the method of supporting the Christmas tree. Many trees get upset through lack of sufficient support and, in cases where ordinary coloured candles are used for decoration, the result of the upset may become serious.

An attractive way to support the tree is shown in Fig. 1, where the box can be filled with soil to keep it alive for transferring to the garden later. The base (Fig. 2) is a piece of oak 12in. square and 1/2in. thick. If the tree is purchased without a root, or if the root is not required, a guide for the end is made in the centre with stripwood as shown. The stripwood is glued to the base, and the size of the opening depends on the diameter of the tree stem at the bottom.

The sides of the box are cut from three-ply, 10in. wide by 9in. high, and one side is provided with a packing strip on to which

A "PRACTICAL" Solution to the Gift Problem!

HAVE you thought of giving Gift Subscriptions for one of the famous "Practical" Magazines edited by F. J. Camm? They make ideal Christmas presents—and most of your friends are sure to be delighted to receive one of them.

WRITE today to the Subscription Manager (G.2), "PRACTICAL MAGAZINES," Tower House, Southampton Street, Strand, London, W.C.2, enclosing the names and addresses of your friends, the titles of the magazines you wish to send them, and remittance to cover. An attractive greetings card will be sent off, in your name, to announce each gift in good time for Christmas.

A YEAR'S subscription to PRACTICAL MECHANICS and PRACTICAL MOTORIST & MOTOR CYCLIST costs 14s., including postage to any part of the world (Canada 13s.); to PRACTICAL TELEVISION and PRACTICAL WIRELESS 13s. 6d. (Canada 13s.), and to PRACTICAL ENGINEERING £1 12s. 6d. (Canada £1 10s. 4d.).

Mechanical Games for the Festive Season

Some Novel and Amusing Games Which Can be Constructed Cheaply From Odds and Ends

DURING the winter and at Christmas time in particular indoor games are in great demand; the following are details of one or two that can be made quite inexpensively at home.

Table Skittles

It will be seen from Fig. 1 that the board has nine skittles arranged at one end of a raised platform, and these skittles have to be knocked over by a hardwood ball, which swings from the top of a wooden rod fixed at

rod. A wooden drawer knob can be screwed into one end of the rod.

A small block of wood measuring 3in. x 2in. x 2in. having a 1/4in.

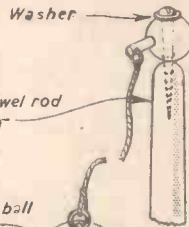

shown in Fig. 2. When the twine is taut the knob should be about 1in. from the front of the board. After the twine has been fixed satisfactorily the baseboard can be secured in place, from underneath, so that an equal amount projects all around the raised platform.

The rod from which the ball swings is a 2ft. length of 1/4in. dowel rod slightly rounded at the top end, in the centre of which a hole is made to take a 2in. wood screw as shown in Fig. 2. A wooden ball foot about the same diameter as the rod has a hole drilled through it so that it fits the screw loosely. A smaller hole is made through the stem of the ball foot for one end of the fine string which holds the hardwood ball. The other end of the string is tied to a screw eye driven into the ball, as shown in the sketch. The string should be just long enough to allow the ball to clear the top of the platform. If desired a different number can be painted on the board beside each skittle for scoring purposes.

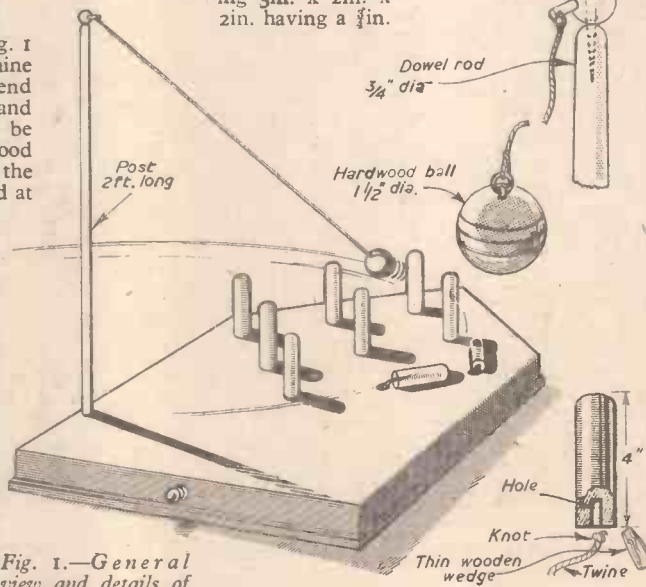

Fig. 1.—General view and details of table skittles showing how the ball is swung from the post.

hole through it is screwed to one of the sides, as in Fig. 2, and holds the vertical rod firmly in position. The hole in the block is, of course, continued through the platform.

Making the Skittles

The skittles, which are 4in. long, can be cut from a piece of 1/4in. dowel rod—a broom handle would do equally well. The bottom ends of the skittles must be quite square with the sides, while the tops can be rounded and smoothed with glasspaper. In the bottom end of each skittle bore a hole about 1/4in. deep, as in Fig. 1, and glue in the knotted end of a piece of twine 18in. long. Before the glue sets push in a thin wooden wedge. After the glue has set hard pass the pieces of twine through the holes in the platform, pull all the ends together so that all the skittles stand upright, and then bind the ends of the twine to the end of the short piece of dowel rod, as

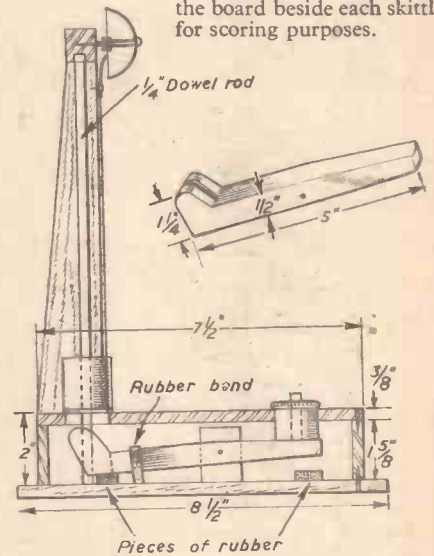

Fig. 4.—Section through the base of the "Nokitup" game and details of the striker trigger.

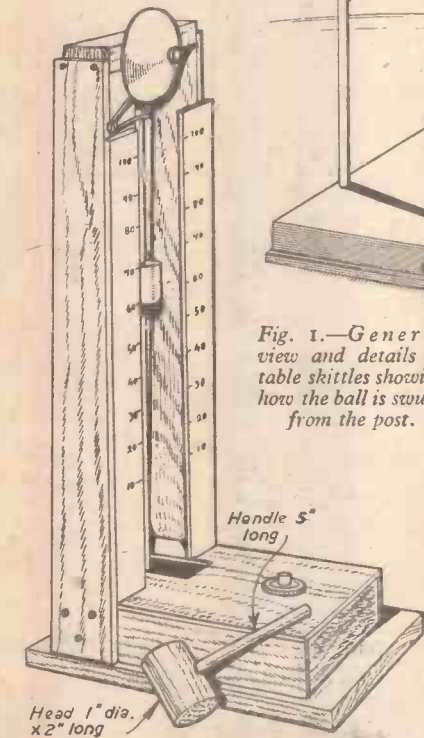

Fig. 3.—A novel game made from a cotton reel and odd pieces of wood.

one side of the board. By pulling the knob at the front of the board all the skittles can be brought up quickly in position again.

The baseboard consists of a piece of five-ply wood 2ft. long and 1ft. 3in. wide, one end being cut to a right-angled point, as indicated in Fig. 2. The raised platform on which the skittles stand can also be cut from a piece of five-ply, and should be 1/4in. less in length and width than the baseboard. Set out the positions of the nine holes, as in Fig. 2, and bore these through the platform with a 1/4in. bradawl, then cut five pieces of 1 1/4in. x 1/4in. stripwood to the required lengths and screw or nail these on the platform so that they come flush with the edges, as in Fig. 1. Bore a hole in the centre of the front strip to take a piece of 1/4in. dowel rod (about 5in. long) and fit a screw eye to act as a guide for the

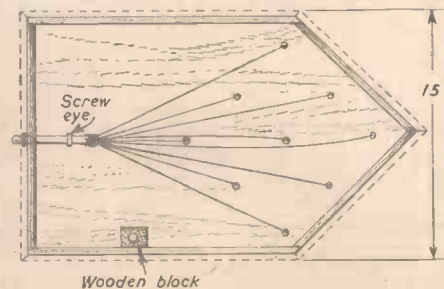

Fig. 2.—The underside of the table skittles board, showing the strings for pulling the fallen skittles in position.

"Nokitup"

For want of a better name the novel game shown in Fig. 3 is called "Nokitup." It will be noticed that it somewhat resembles the apparatus often seen at fairs which requires a strong man with a heavy mallet to ring the bell at the top. With this simple toy the same sort of fun can be had in miniature on the dining-room table.

The Base and Trigger Piece

The box shaped base is built up from pieces of 1/4in. wood screwed together as indicated in Fig. 4. Near one end of the top of the box a rectangular hole is cut and near the other end a circular hole to take half a cotton reel, which forms a guide for the small plunger

a 1 1/4 in. length of 1/4 in. dowel rod). Mounted inside the box between two wooden bearing pieces is a trigger piece, shaped, as shown in Fig. 4, from a piece of hardwood. This pivots on a piece of iron rod cut from a straight French nail. Two pieces of soft rubber are fixed to the baseboard, one below each end of the trigger piece, to act as buffers. A rubber band, held in place by a strip of wood nailed to the baseboard, holds the slotted end of the trigger down till the plunger is hit with the mallet.

A piece of 1/4 in. dowel rod 20 in. long will now be required and also a cotton reel. Choose one with narrow flanges and enlarge the central hole so that it is an easy sliding fit on the dowel rod. Through the side of the reel bore a 3/16 in. hole at right angles to the central hole and cut a short piece of rod which fits the hole loosely and projects about 1/16 in. when the inner end touches the dowel rod. Cut a notch in the projecting end of the short piece of rod and pass a fine rubber band round the cotton reel so as to engage in the notch, as shown in Fig. 5. The pressure on the little plunger must be sufficient to hold the

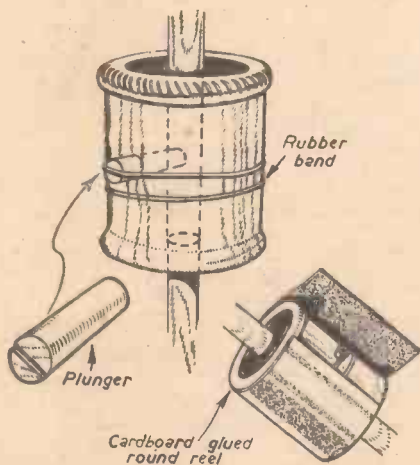

Fig. 5.—Details of the cotton reel and plunger.

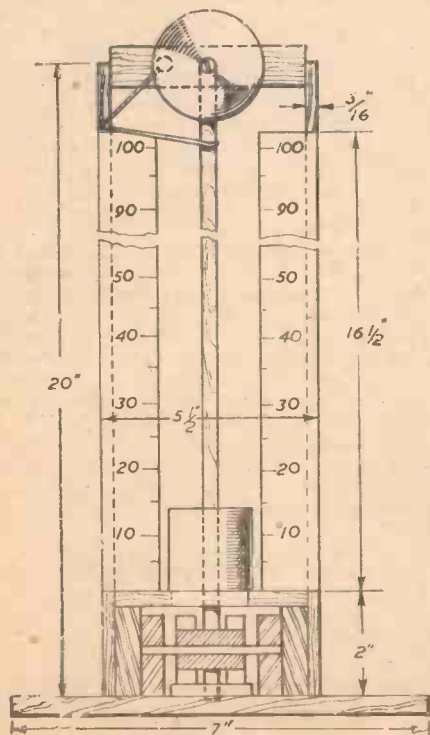

Fig. 6.—Part sectional front view of the "Nokitup" game showing the scoring scales.

Spring to return lower board

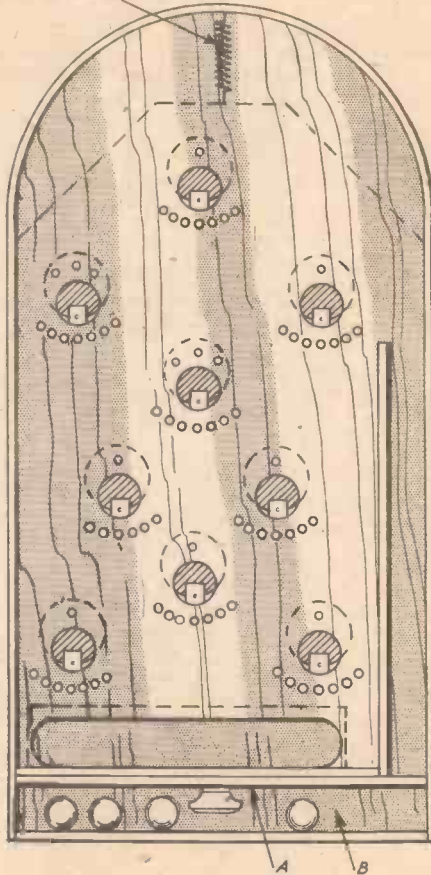

Fig. 7.—A plan view of the converted bagatelle table.

cotton reel in any position as it is knocked up the dowel rod.

It may be found necessary to double the band twice round the reel to give the required pressure. The cotton reel can be covered with a casting of thin cardboard, as indicated in Fig. 5.

Fixing the Upright Rod

For supporting the dowel rod two side pieces, each 20 in. long and shaped as shown in Fig. 3, are screwed on each side of the box and between the top ends of the side pieces a cross piece of 1/4 in. square wood is screwed. In the centre of this cross piece a 1/4 in. hole 1/4 in. deep is made to take the top end of the dowel rod, the lower end of which rests in a hole recessed in the baseboard. Two strips of 1/4 in. plywood or stiff white cardboard can be nailed on to the front edges of the side pieces, after marking a scale on them for scoring purposes, as shown in Fig. 6.

For a game of this sort we must, of course, have a bell, and one taken from a discarded alarm clock will answer the purpose admirably. Fix it to the middle of the cross piece with a long screw, using a piece of brass or other tubing as a distance piece. For the hammer bend a piece of iron wire to the shape shown, solder a small iron disc on one end, and screw it loosely to one of the side pieces, so that the hammer strikes the bell on the inside edge when the player scores 100.

The Striker Mallet

The little mallet for striking the plunger is easily made from two pieces of dowel rod of the sizes given in Fig. 5. After the cotton reel has been knocked to any position up the dowel rod it is simply pushed down again to its starting position ready for the next blow of the mallet.

A coating of cellulose paint in one or two

different colours would enhance the appearance of the finished toy, but the dowel rod up which the cotton reel slides must be left plain.

An Electric Pin Table

Many readers have, no doubt, one of the older types of bagatelle tables at home; this may be converted fairly simply into one of the more modern pin tables, and when completed it will be as shown in Fig. 7. (If you do not have such a table one may be constructed from three-ply wood to any desired pattern.) In place of the small brass cups in the older type of board a hole must be drilled. The size will depend upon the balls to be used and these are obtainable up to 1 in.

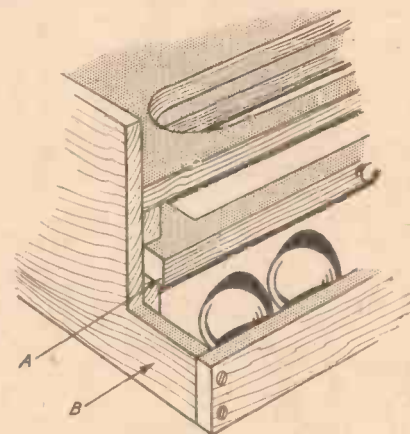

To release balls lower board 'A' is pulled out. The balls fall through and run down the plywood bottom to the end 'B' ready for further play.

Fig. 8.—An end view of the conversion, showing the sliding board.



Fig. 9.—Constructional details of the contacts for pin table signalling.

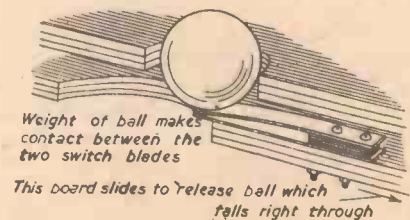

Fig. 10.—The heavy balls make contact as shown here and may be used to give various forms of indication.

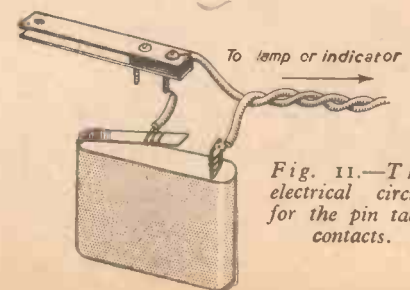

Fig. 11.—The electrical circuit for the pin table contacts.

diameter in steel if desired. A weighty type of ball should be adopted in preference to the lighter type of rubber ball.

A second plywood board is required, almost as large as the original table, and this must be provided with a series of holes forming the same pattern as on the original table, but the holes must be very much larger. Across each hole in this second board a double contacting piece is fitted and it may be built up from thin brass strip and $\frac{1}{4}$ in. ebonite, as shown in Fig. 9. The two strips are screwed or riveted

to the piece of ebonite, suitable dimensions being as given. These may be modified according to the size of the board. At the ends of the two strips a depression is punched by means of a blunt nail, or if a more permanent job is desired a piece of silver wire may be soldered to form a better contact. In Fig. 10 one hole is shown and the position of the contacts as well as the lower hole may be clearly seen. When the ball drops into the hole it presses the two contacts together and these may be made to light a numbered

board, a coloured lamp or other device to suit your own particular needs. The electrical circuit will be as shown in Fig. 11 and this may be duplicated for each hole. To release the balls when they have all been played the lower board is made to slide in between two thin fillets arranged beneath the main board and a simple handle may be fitted so that the board is drawn back and then pushed into position when all the balls have fallen through, or a spring may be fitted to return the board to its original position, see Figs. 7, 8 and 10.

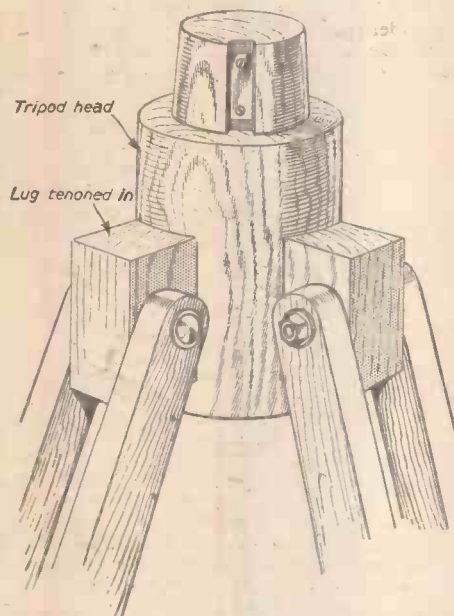

Fig. 1.—A perspective view of a tripod for the Astro Compass, Mark 2.

EITHER of the two designs of tripod described here will give satisfactory service in conjunction with an Astro compass Mark 2, whether the compass is used for star identification, or as a level and theodolite, after modification in the manner described in the September issue of PRACTICAL MECHANICS. The tripod, Fig. 1, is also useful for photography. A short screw, usually $\frac{1}{4}$ in. Whitworth, to fit the camera tripod screw bush, securely fixed to the top of the centre post, enables the camera to be firmly and securely attached to the tripod.

Construction

The tripod shown in Fig. 1 is made almost entirely from wood. Close-grained hardwood should be chosen, such as beech or maple. An excellent alternative would be the resin-impregnated laminated wood which is sometimes available from Government surplus stocks. For the tripod head a piece of wood is prepared $\frac{1}{4}$ in. long and 2 in. diameter. One inch at the top is turned down to $1\frac{1}{16}$ in. diameter, and slightly tapered to fit snugly into the base casting of the compass. A small keyway must be cut to accommodate the thickened portion of the base where the clamping screw fits. A small piece of sheet metal can be screwed into this keyway, or a short, stiff woodscrew could be driven in, to take the pressure of the clamping screw.

Half an inch from the bottom three shallow mortices are cut 60 degrees apart. These mortices are $1\frac{1}{2}$ in. long \times $\frac{1}{2}$ in. wide \times $\frac{1}{2}$ in. deep. The area around each mortice is worked flat with saw, chisel and rasp to enable the shoulders of the $1\frac{1}{2}$ in. \times 1 in. lugs to fit accurately. The three lugs are cut from specially selected hardwood, well seasoned, hard and tough. Suitable wood can be obtained from discarded furniture of good

quality. The tenons should be worked on the end grain, to give extra strength, and they must be a good fit in the mortices. Both the mortices and the tenons should be coated with one of the synthetic waterproof glues, the lugs inserted in position, and bound round with string until set. A couple of 2 in. fine gauge woodscrews can be driven in, one on either side of the pivot hole position, through each lug and into the centre post, if thought necessary. A glance at Fig. 2 should make the construction clear.

The Legs

Each leg of the tripod is made up of two 4 ft. 6 in. lengths of hardwood $\frac{1}{4}$ in. \times $\frac{3}{8}$ in. in section. The two lengths are screwed together at the bottom, but in the middle of the length a spacer $\frac{1}{2}$ in. thick is inserted, and a similar spacer, but 1 in. thick, is inserted 3 in. down from the top. All the joints should be glued as well as screwed together. The tops of the legs are rounded off to a radius, and a pivot hole drilled through the centre. It is as well to drill the pivot holes slightly undersize at first. Then with each leg in its respective position over its lug, the pivot holes can be marked through on to the lug and drilled, again slightly undersize. The three holes

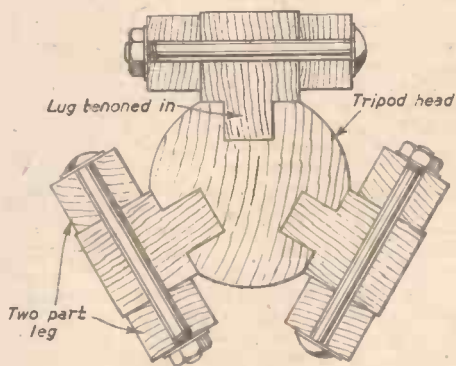

Fig. 2.—Constructional details of the tripod.



Fig. 3.—Details of the legs.

can then be lined up precisely by reaming out with a $\frac{1}{4}$ in. diameter reamer. Turned brass or steel bolts $2\frac{1}{2}$ in. long \times $\frac{1}{4}$ in. diameter are now fitted into the holes, washers put under the heads and nuts, and the nuts tightened until the legs move stiffly. The top spacing piece being 3 in. down allows the legs to be sprung in sufficiently to grip the lugs, and ensure the required stiffness of working which is essential

A Tripod for an Astro-Compass Conversion

By J. VOSE, A.M.S.E.

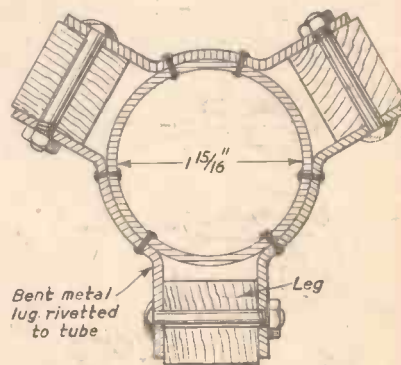

Fig. 4.—An alternative design.

to maintain stability in the finished tripod. The joints can be lubricated with a little beeswax. Fig. 3 shows a view of one leg.

The tripod can be nicely cleaned up, sharp edges taken off with fine sandpaper, and finished by staining, if desired. A couple of coats of hard copal varnish, outside quality, will protect it from the elements.

An Alternative Design

The tripod shown in Fig. 4 is made from a $\frac{1}{4}$ in. length of brass or steel tube having an internal diameter which just admits the base of the compass. A slot $\frac{1}{4}$ in. wide \times 1 in. long is necessary to allow the clamping screw of the compass to slide down. The key on the base of the compass can be filed away, as it is not necessary for our purpose.

The lugs for this tripod are bent up out of $1\frac{1}{2}$ in. \times $\frac{1}{4}$ in. strip brass or steel to the shape shown in the drawing, and are riveted to the tube as shown. Or they can be brazed, or welded on, if facilities are available. The legs are simply straight lengths of $1\frac{1}{2}$ in. \times $\frac{3}{8}$ in. hardwood, rounded to a radius at the top and drilled for the pivots as before, and shaped to a tapered round section below. Note that this design of tripod is not suitable for use with a camera, as a camera tripod screw cannot be fitted to the top.

Model Boat Building

By F. J. CAMM

5/-, By post 5/6

From GEORGE NEWNES, LTD.,
Tower House, Southampton Street,
Strand, W.C.2

Home-made Xmas Crackers

Details of a Jig for Making Crackers of a Professional Appearance

By H. R. MATHIAS

FIG. 1 shows the components of a cracker and the first task is to make the cardboard tubes to strengthen the inner section. Make these with very thin cardboard by curving it over one of the formers A, B, C (Fig. 2), and sticking with paste. The outer pieces of paper are cut as shown in two sections to facilitate breaking of the cracker on pulling. It is best to put a small dab of paste at the points shown "a" to stick them in advance to the larger piece of crepe paper. When this is all done, put former pieces A and B together as shown, slide a

pivoted at one end M. The cracker, rolled up on the formers as described, is laid along the support and the three-hinged clamp plates pulled down on top. Fig. 4 shows one of

A small wooden bar is inserted in each lever as shown, to bear on these pads. Initially only the right-hand lever is applied, the left-hand clamp plate being left lying loosely on the cracker. The cord H is then grasped at F and G and by bringing G hard over is

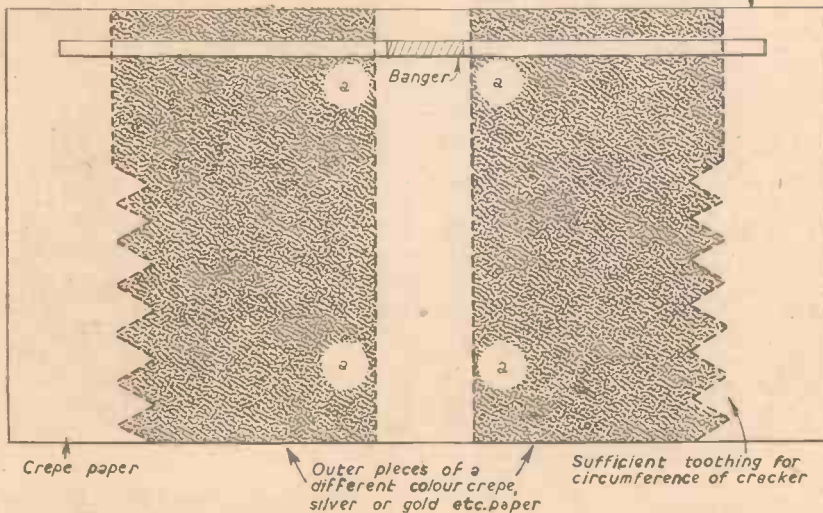
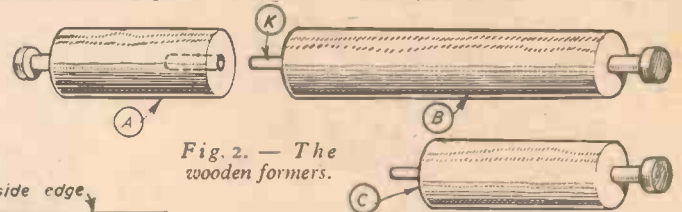

Fig. 1.—The components of a cracker.

tightened up on to the connecting bar K between the formers, crimping the paper neatly as it does so.

The lever and clamp plates are thrown back, the former B removed leaving the stout cardboard tube previously referred to just inside the cracker as a guide. The support is then hinged up and the paper hat of tissue paper and the present or trinket dropped inside the cracker's central section. The support is dropped back, the former C being inserted instead of B on the right-hand end, inside the guide tube, and the procedure is repeated this time applying pressure only on the two left-hand clamp plates and letting the right-hand one lie loosely. The right-hand crimp is now formed as for the left hand, using the cord L. Hinge back the clamps, remove the cracker from the supports, take out the formers and the cardboard guide tube and all is ready for the next one. Small stick-on figures for the outside of the cracker centre can be purchased at multiple stores.

cardboard tube to the centre, and put another similar but stouter tube over the right-hand end of former B. The purpose of this tube will be clear later. Roll up the paper on to the formers with the banger just inside the paper. These bangers can be bought from many novelty shops for 6s. a gross.

the two levers which hinge at N between each pair of clamp plates.

This lever puts pressure on to two clamp plates at a time via the shaped pad P of which there are a total of four, one on each side of each lever.

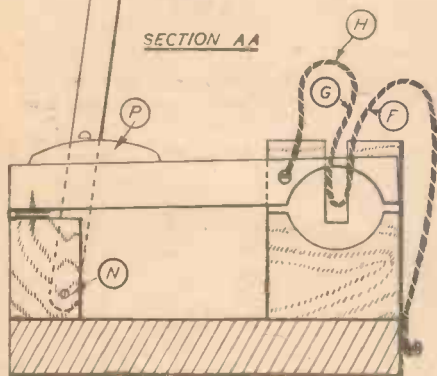

Fig. 4.—A section on line AA (Fig. 3).

Details of the Jig

Figs. 3 and 4 show the general arrangement of the jig. It consists essentially of a support for the rolled up cracker and a set of clamps to hold it firmly while the crimping is done neatly. Three sections of wood are hollowed out as shown with a diameter a little less than that of the finished cracker. They are mounted on a common base (J) which is

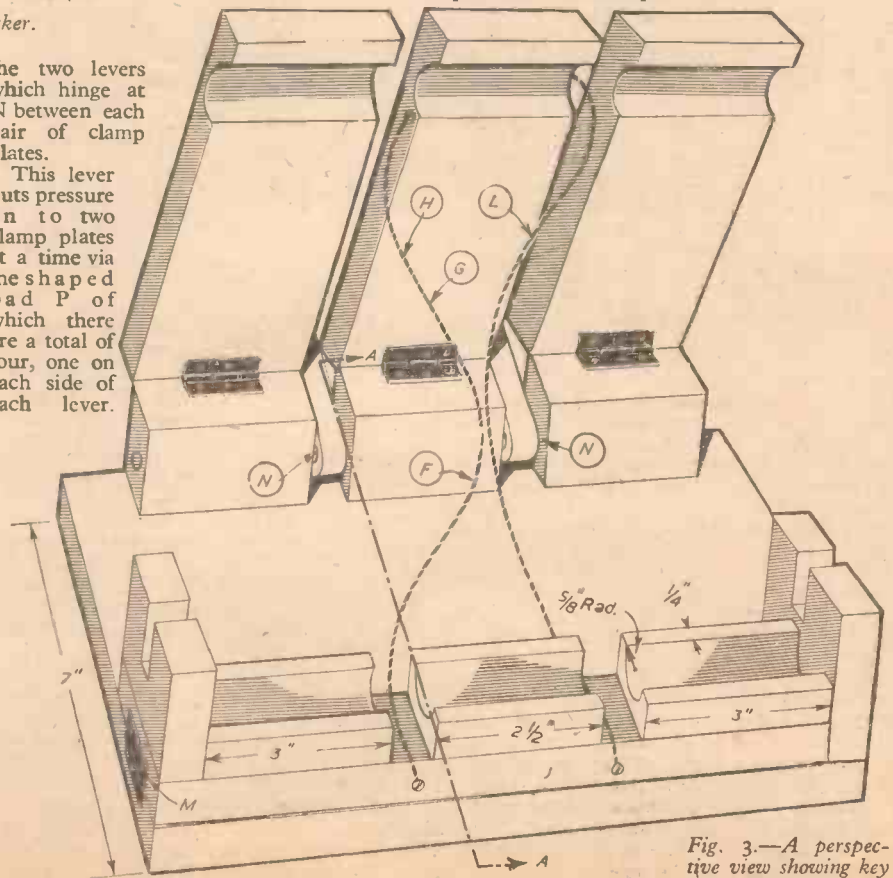

Fig. 3.—A perspective view showing key dimensions.



Home-made Fishing Tackle

A Series of Articles Dealing With the Construction of a General Purpose Fresh Water Rod : a Sea Rod and Reels in Wood and Light Alloy

4.—A Wooden Reel

By C. W. TAYLOR, M.I.E.T.

THE reel which is to be described in this article is a contracted type with a large diameter drum for rapid recovery of line.

The advantage of using a large diameter drum is readily appreciated when casting at long range.

Materials

The materials necessary for the construction of the reel are as follows :—

A block of wood, either walnut or teak, 5 1/2 in. square by 1 3/4 in. thick ;

A piece of walnut or teak 3 3/4 in. square by 1/2 in. thick ;

A piece of 1/16 in. thick brass plate 4 in. x 2 1/2 in. ;

A strip of brass, 4 in. x 1/4 in. x 1/16 in. ;

Short pieces of 3/32 in., 1/4 in., and 1/2 in. diameter brass bar ;

The above procedure must, of course, be adopted to ensure that the drum will run true. Simply turning the wood and drilling it will not guarantee that the drum will run true.

on the periphery of the flange are carefully spaced out and filed to depth (about 1/16 in.), using a triangular saw file. This component should be case-hardened. The bush is buried in a small tin of "Kasent" powder, and the

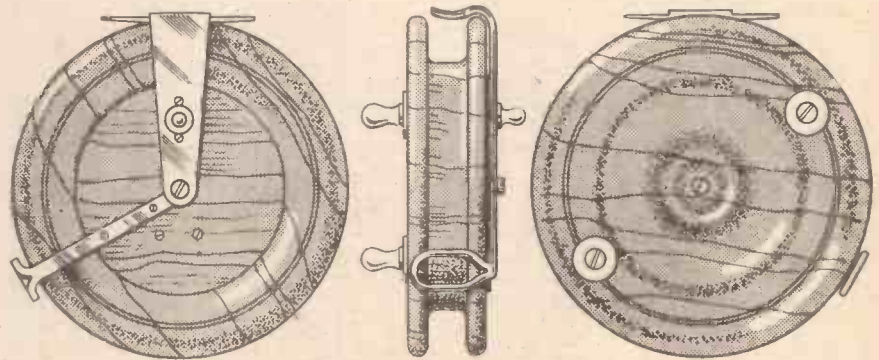

Three views of the completed reel.

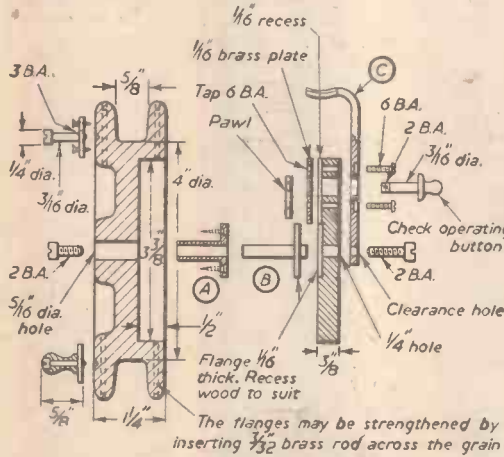

Fig. 1.—The component parts of the reel ready for assembly.

Short pieces of 3/32 in. diameter brass wire, and a small piece of 1/16 in. thick brass plate ;

Small pieces of 1 in. diameter mild steel, and a small piece of carbon tool steel 3/32 in. thick ;

A 6 in. strip of 1/4 in. x .048 in. spring steel ;

The Drum and Disc

The block of walnut or teak should first be rough turned and a 5/16 in. diameter hole drilled through the centre. The wood is then mounted on a piece of 5/16 in. diameter rod, screwed at one end to take a nut for clamping the wood block ; a long 5/16 in. bolt shank and nut would suit. The rod or bolt shank is gripped in a three-jaw chuck and the wood block is tightened against the chuck jaws by screwing up the nut. The reel drum is then finish turned true with the hole.

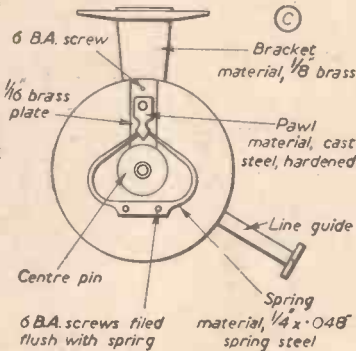

Fig. 2.—Stationary disc showing checkwork.

Having turned the drum, the flanges may be strengthened by carefully drilling the 3/32 in. holes to take strengthening rods, made from 3/32 in. brass wire. These are inserted across the grain of the wood, and are tapped slightly below the surface. The holes are then plugged with plastic wood.

The piece of wood measuring 3 3/4 in. square by 1/2 in. thick is next turned to a disc 3 3/4 in. diameter by 1/2 in. thick, and a 1/2 in. hole is drilled through the centre. The disc is turned to enter the recess in the drum with a clearance of, say, 1/20 in. The disc is later screwed to the brass bracket shown in Fig. 6.

The Check Wheel Bush

The flanged bush is turned from a piece of 1 in. diameter mild steel. The outside diameter of the bush is 5/16 in. and is a push or tap fit in the wooden drum (see Fig. 4). The teeth

tin and contents are heated to a bright cherry red for half an hour or longer. The bush is then removed from the tin, cleaned, reheated to a cherry red and finally quenched in clean water.

The Centre Pin

The flanged centre pin (Fig. 5) is also turned from a piece of 1 in. diameter mild steel and is a good running fit in the check wheel bush. The bore of the bush and the pin should be given a polished finish. As indicated in Fig. 5, the pin should be turned about .003 in. longer than the bush.

The Bracket

The bracket, by means of which the reel is clipped to the rod, is sawn and shaped from

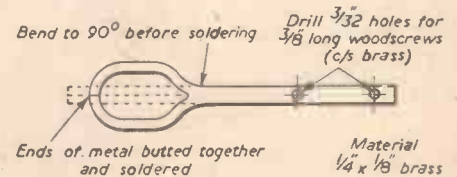

Fig. 3.—The line guide.

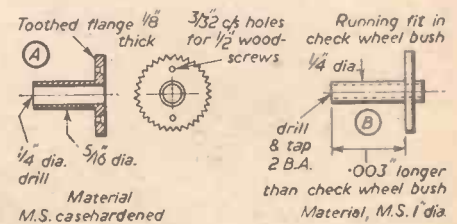
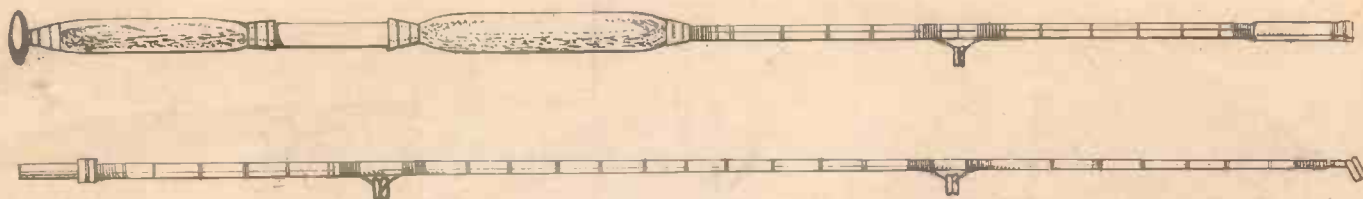

Fig. 4.—The check wheel bush.

Fig. 5.—The centre pin.



An additional illustration of the 2-joint 8ft. sea rod, details of which appeared last month.

the piece of $\frac{1}{4}$ in. brass plate, measuring 4in. by 2 $\frac{1}{2}$ in. This bracket can be bent to shape without damage if it is gripped very tightly between two pieces of wood in the vice, using a third piece of wood on which to hammer, when bending over the metal.

The bracket should be well finished by draw filing the edges, emery clothing to remove scratches, and later burnishing or buffing to a good polished finish.

The slot which is cut in the bracket should be just sufficiently long to enable the check operating button to engage and disengage the pawl and check wheel. A similar slot has also to be cut in the wooden disc and the piece of $\frac{1}{16}$ in. brass plate over which the pawl moves. The holes for the No. 6 B.A. screws are best left until the above components have had the slot cut in them and satisfactory alignment has been achieved. The slot may be cut by drilling two $\frac{3}{16}$ in. holes the correct distance apart and filing away the unwanted metal with a rat-tail file.

The Line Guide

The line guide is made from the piece of brass measuring 4in. \times $\frac{1}{2}$ in. \times $\frac{1}{4}$ in. A saw cut about 1 $\frac{1}{2}$ in. long is made down the centre of the $\frac{1}{2}$ in. wide face and the metal is prised open in the form of a Y. The corners inside the two arms of the Y are next carefully filed so that the metal becomes a half circle in section.

All sharp corners must be removed and the brass is emery clothed to a smooth finish. The remaining bends are then made, the ends are butted together and neatly soldered. Two $\frac{3}{32}$ in. countersunk holes are drilled to take $\frac{3}{8}$ in. long woodscrews, and the guide is screwed to the wooden disc. The most suitable position for the guide is shown approximately in the sketch.

The Handles

The handles for the reel are made from $\frac{3}{8}$ in. diameter brass bar, and the specially turned pins for these are made a good running fit.

The thin brass discs to which the handles are fixed are parted off from $\frac{3}{8}$ in. diameter brass after this has been drilled and tapped No. 3 B.A. for the pins. The discs each have two $\frac{3}{32}$ in. countersunk holes for the woodscrews, by which they are secured to the drum.

The Pawl, Spring and Button

The remaining components, together with the toothed wheel previously described, form the mechanism for the check.

It is well known that the check of a reel provides a suitable resistance against which a large fish can pull; it is also used to stop line being continually taken out by tidal or flowing water, and is used to avoid over-running of the reel.

The pawl is made from a small piece of carbon tool steel which is hardened by heating to a bright cherry red and quenching in water. It can be left in the "dead hard" condition.

The spring is made from the $\frac{1}{4}$ in. \times .048in. spring steel. Each end of the strip is suitably reduced by grinding or filing, and the ends are carefully rounded and smoothed with emery cloth. The thin portions, which are straight tapered, are then bent to shape and the two holes drilled and tapped for No. 6 B.A. screws.

The ends of the spring should be bent

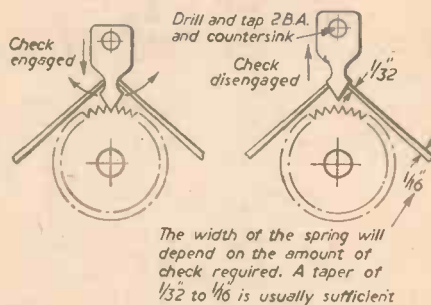

Fig. 7.—The action of the pawl in the check wheel bush.

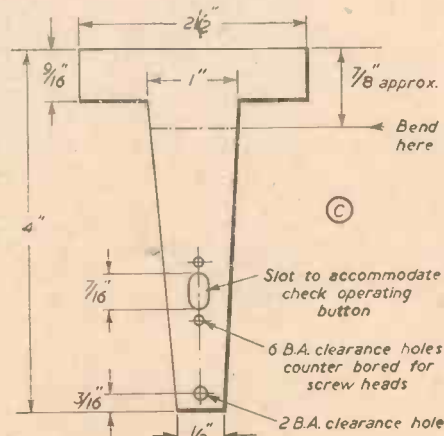

Fig. 6.—The bracket.

round so that the gap between them is slightly larger (about $\frac{1}{32}$ in.) than the neck or reduced part of the pawl. This allowance is made because in hardening the spring, a slight change in the shape of the spring invariably takes place, due to uneven heating and consequent uneven expansion of the steel. The ends of the spring usually close in slightly and for this reason the gap between the ends must include a suitable allowance.

Hardening and tempering the spring can prove somewhat tricky. If the job is undertaken using a gas ring, a piece of thin metal plate held over the spring will reflect and distribute the heat more evenly. The spring should be quenched in oil or warm water from a bright red heat.

Having hardened the spring, it should be

brightened by rubbing with emery cloth (care must, of course, be taken as the spring will be brittle and will easily snap) and then tempered by reheating slowly until the steel turns to a uniform blue colour. This, of course, occurs at approximately 300 deg. C. Tempering the spring is more easily achieved by holding the spring in an old pair of pliers some distance away from the source of heat, moving the spring with a continuous circular movement.

The check operating button is turned from $\frac{1}{4}$ in. diameter brass bar, and the shank is made $\frac{3}{16}$ in. diameter to enter the slot in the brass bracket. The end of the button is screwed No. 2 B.A. for just three or four threads.

Assembling the Reel

For the drum to rotate freely, obviously the centre pin must be a few thousandths of an inch longer than the check wheel bush.

This also applies to the handles; the pins must be slightly longer, when screwed in position, than the handles which rotate on them.

Care must be taken over the alignment of the slots and holes cut in the $\frac{1}{16}$ in. plate, the wooden disc and the bracket. It is best to drill the bracket first and mark the positions of the holes on the other two components by clamping together and spotting, or by drilling straight through them.

The length of the button shank is important, since it must screw into the pawl down to the last thread without tightening against the $\frac{1}{16}$ in. plate. In operation the button oscillates with the pawl.

The spring should be positioned with the pawl engaging the toothed check wheel. In this position the ends of the spring will lie in the neck of the pawl, and the exact positions for the No. 6 B.A. clearance holes in the wooden disc can be marked and drilled.

The drum and disc should be french polished when all the components have been tried and satisfactorily fitted in position. All the parts are, of course, removed for polishing the wood.

The bracket, guide and handles can be buffed or burnished and lacquered.

The final assembly will involve riveting over the end of the check button after it is screwed into the pawl. This should be left until last since these cannot afterwards be separated. During the assembling of the reel, clearance must be maintained between the checkwork and the drum.

In "The Practical Motorist and Motor Cyclist"

December Issue now On Sale

Principal Contents:

Curing Valve Noises; Radlator Repairs; More Miles to the Gallon; Simple Motor Body Repairs; Repairing Leaf Springs; Overhauling the Morris Minor and Eight; The Winter Check; Rear Axle Oil Leakage; Motor Cycle Electrical Maintenance; Motor Cycle Overhaul; our Experts Advise and many other valuable articles.

WEATHER MECHANICS

2 —

AIR PRESSURE

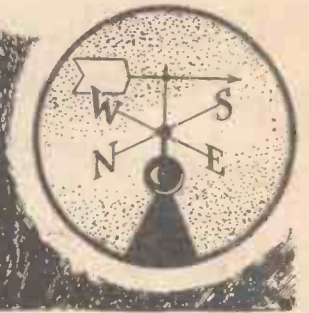

Wind and Rainfall Governed by Pressure Variation. Use of Isotherms and Isobars. Relationship of Temperature and Pressure

WEATHER is created by a series of physical and chemical actions which occur on a vast scale from surface level to many kilometres above the surface. Meteorology is unique among the sciences in that it demands careful and persistent observation over a very wide area in the formulation of the weather map. Variations of pressure and temperature in regard to height must be noted, also the continuous change of pressure associated with the earth's axial rotation. This special knowledge must then be co-ordinated with the findings of the laboratory dealing with the laws of vapours and gases, sound and optics, heat and radiation and electricity and magnetism. Indeed, the science of

By WILLIAM ELLWOOD

indicated in Fig. 1; also that air flows from areas of high pressure to areas of low pressure. However, the irregular distribution of land masses, particularly in the northern hemisphere, quickly spoils most attempts at orderliness and symmetry.

The uniform distribution of temperature is disrupted due to land heating and cooling more quickly than oceanic areas, even when land and water occupy similar latitudes. This variation directly affects atmospheric pressure, therefore wind direction.

As winds are the rain carriers, it becomes clear that temperature distribution is a matter of prime importance. We may give a single example of this importance in Fig. 2. In the northern winter, the vast land mass of central Asia becomes intensely cold and thus forms an extensive area of high pressure. The cold air flows towards the south-west in accordance with the circumstances previously outlined. Of this, we in the British Isles have had some experience!

It is, however, in India that the sequence occurs with unfailing regularity. January is the time of the north-east monsoon. As it comes from a cold dry region it brings no moisture with it. This is the dry season in India. When the earth reaches summer

moisture-laden and brings to the Western Ghats and south-east Asia, one of the greatest rainfalls to be encountered on the planetary surface. This is the south-west monsoon.

Other examples of similar nature may be discovered in the maps of seasonal winds and rainfall given in Fig. 3. Included in the latter is an idealistic wind map which may be used for comparison. It will be seen that there is no very great difference between theory and actuality in the southern hemisphere. This is due to the widespread oceanic area which heats or cools with reasonable uniformity, relevant to any particular latitudinal band.

The Isotherm

In Fig. 4 we have maps which inform us with admirable promptitude of the variations of atmospheric temperature over the earth's surface, during two different months of the

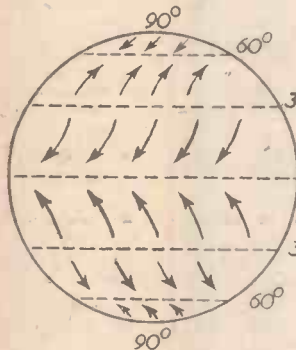

Fig. 1.—Generalised wind directions.

findings of the laboratory dealing with the laws of vapours and gases, sound and optics, heat and radiation and electricity and magnetism. Indeed, the science of

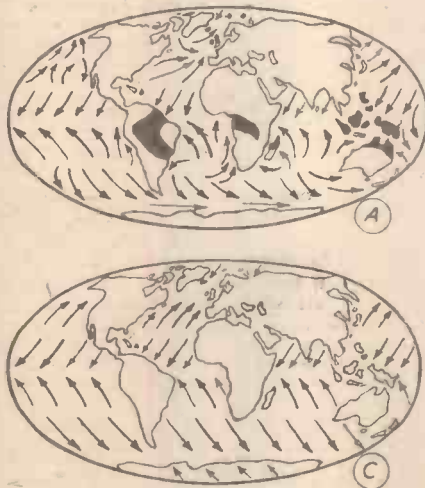

Fig. 3.—Prevailing winds and heavy rainfall areas.

meteorology in the latter respect shows a great affinity to the science of physics. In our present discussion we are considering the former or special knowledge; that is, the vital part which temperature and pressure play in our weather.

Land Distribution Affects Wind Direction.

Last month we established that, ideally one may say, the prevailing winds are as



Over 40in. of rain in six months. A—January winds and heavy rainfall experienced from November to April. B—July winds and heavy rainfall experienced from May to October. C—Idealistic wind map.

solstice, the Asian land mass becomes very hot, the wind direction reverses and flows north-east over the warm Indian ocean. It is

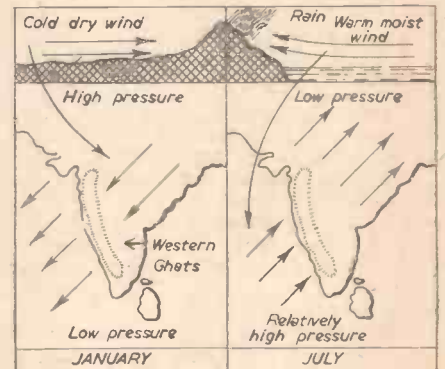

Fig. 2.—N.E. and S.W. monsoons.

year. The heavy lines superimposed on the global surface are called isotherms. These imaginary lines link all points of a region or band of latitudes which register the same temperature. The more closely graded the variations of temperature to be recorded, the more isotherms there must be drawn which, as a result, enables a more accurate temperature assessment to be made of any restricted area. It should be pointed out here, that all isotherms appearing on a temperature map are sea level temperatures; otherwise the variations existing over mountainous territory would crowd the map with misleading and useless detail.



Fig. 4.—Mean temperatures over the earth's surface given in degrees Fahrenheit, extreme isotherms omitted.

This conversion to sea level temperature is carried out by the simple expedient of adding 1° F. to the observed temperature for every 300ft. above sea level. Therefore, a station 900ft. above sea level, recording a temperature

Whilst this is not strictly correct on an ideal absolute or "A" scale, the difference is so small as to be immaterial. This slight discrepancy is usually acknowledged by the centigrade reading, plus 273°, being termed the

A thousand millibars is approximately equivalent to 14½ lbs. per sq. in., our standard atmospheric pressure. This equivalent, however, varies with latitude.

As an added point of interest, Fig. 6 has been inserted to give some idea of the relationship between temperature and pressure. Rises in the temperature of a gas may be dealt with in two ways: 1, at constant volume, and 2, at constant pressure. In the first instance an increase in temperature will result in an increase in pressure; in the second case, an increase in volume will occur. In a delicate experiment the increase in pressure of a fixed volume of gas under varying temperatures may be assessed, and thus the relation between pressure and temperature (Fig. 7). Let P_x equal the pressure at 0°C. and let P_t equal the pressure at t°C. The relation between these may be expressed as $P_t = P_x (1 + \beta t)$

where β is a constant equal to $\frac{P_t - P_x}{P_x t}$.

In this case, β may be termed the coefficient of pressure increase at constant volume. It possesses a value of approximately $\frac{1}{273}$. The curve indicates that it would intersect the axis at -273°C. This is the result if we consider the following:

$$\text{when } t = -20^\circ\text{C.}, P_t = P_x \left(1 - \frac{20}{273} \right)$$

$$\text{and when } t = -273, P_t = P_x \left(1 - \frac{273}{273} \right) = 0.$$

It will be obvious that the principle involved forms the basis of the aforementioned gas-thermometer.

Having briefly reviewed the two most important meteorological gauges, isotherms and isobars, we shall discuss next month, the development of a depression and the formulation of weather maps.



Fig. 5.—Atmospheric pressure over the earth's surface given in millibars. Extreme isobars omitted.

of 45° F. would have a corrected temperature of 48° F.

Forms of Temperature Scale

We may at this point digress slightly in order to clear up the relationship of the temperature scales used in meteorology and physics. They are the Fahrenheit, centigrade and absolute scales. The means of relating C. and F. temperatures is as follows: Freezing point of water.....32° F.....0° C. Boiling-point of water.....212° F.....100° C.

$$\text{Thus, to convert F. to C.: } C. = \frac{5}{9} (F. - 32)$$

$$\text{e.g., } \frac{5}{9} (59^\circ \text{ F.} - 32^\circ) = 15^\circ \text{ C.}$$

$$\text{Conversely, } F. = \frac{9}{5} C. + 32$$

The absolute scale is a scale of temperature which is independent of the nature of the thermometric substance. The best known way of arriving at an absolute temperature is indirect and based upon the thermodynamic principles of the relation between heat and work. A gas-thermometer of constant volume coincides very nearly to the absolute scale. Hydrogen is highly suitable. At absolute zero the hydrogen of a gas-thermometer would have no pressure and the heat-to-work limit of conversion would be reached. From a precise measuring point of view, the absolute zero is a theoretical condition though temperature has been brought down to within 1° absolute. The 0°C. freezing-point of water is equal to 273° on the absolute scale.

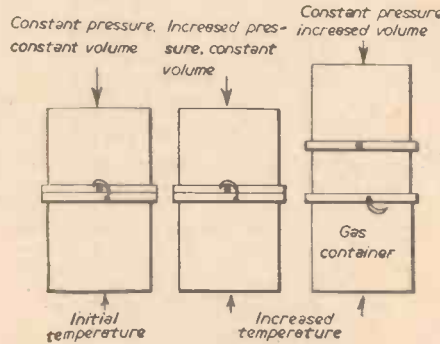

Fig. 6.—The relationship of temperature and pressure.

tercentesimal temperature (tt); but the resulting figure is used in calculation as the absolute temperature, T, without any further correction. ∴ t°C. = (273 + t)° A = T°.

The Isobar

The maps in Fig. 5 inform us of the various atmospheric pressures over the earth's surface, during two different months of the year. In this case the heavy lines connect all points of identical pressure and are named isobars. As with isotherms, the isobars are corrected to sea level pressures on maps which cover a large area. In fact, the correction may be to any set level above the surface. These levels are termed "isobaric surfaces." The pressure is usually expressed in millibars.

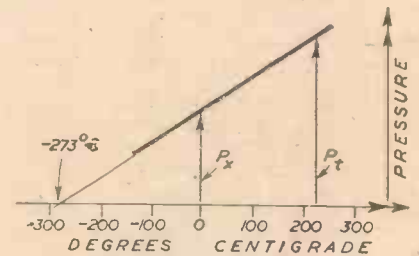

Fig. 7.—Pressure-temperature curve.

"The Flying Bedstead"

THIS machine was built by Rolls-Royce as a test vehicle for examining the basic control problems of aircraft taking off and landing in a near vertical flight path. No attempt was made to develop special engines; instead, the simplest and lightest framework was built which could use existing engines. Two Rolls-Royce Nene engines were chosen and set horizontally in opposition, one on either end of the framework. The jets from these engines are ducted through 90 deg. so that both engines discharge vertically downwards under the centre of gravity. The pilot sits on a platform above the two engines and the control moments which he needs to balance the machine are supplied by compressed air jets which are discharged through nozzles at the ends of cross arms which can be seen clearly in the picture. The air for these nozzles is bled from both engines and the pilot, using a conventional control column, and rudder bar, regulates the flow through the nozzles.

In the initial tests, in order to safeguard the machine and the pilot, the "Flying Bedstead" was tethered to allow it only the limited movement of a few feet. With increasing experience and confidence the freedom permitted was increased

until finally, all check wires were removed and the machine, piloted by Captain Shepherd, took off for the first time in free flight. It remained airborne for nearly ten minutes and

during this time it moved about over the ground under the pilot's control at heights of from 5ft. to 10ft. For subsequent flights it has been flown free at heights up to 25ft.

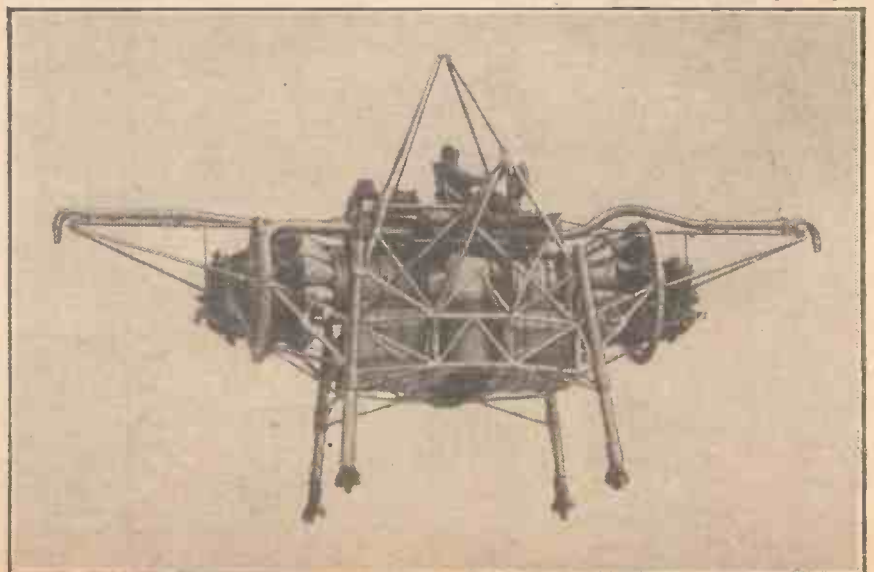

Small Tools in the Home Workshop

2.—Making a Simple Two-tooth Cutter and a Fly Cutter

By "TOOL DESIGNER"

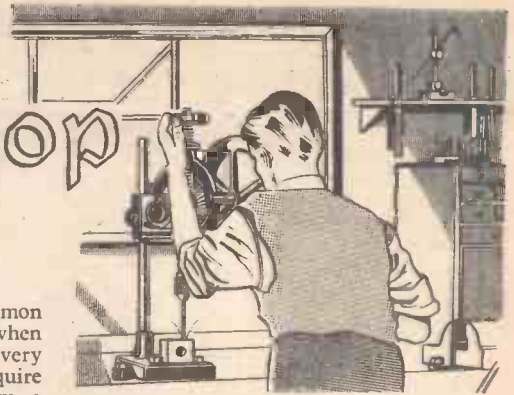

FEW amateur workshops have a milling machine as part of their equipment, and as all models made in metal generally require a fair amount of milling in order to produce various flat and curved surfaces most of this work is performed on the lathe.

The tools, however, for both machines do not differ, and any type is easily transferred providing there is sufficient room to allow it to swing and the shank is made to fit the appropriate spindle. The latter is, as a rule, a Morse taper and for this height and class of machine tool it is either No. 1 or 2.

There are two versions of a milling machine—the vertical and horizontal—in other words, the spindle in the lathe is arranged horizontally, while the former machine uses the mandrel vertically.

Horizontal milling cutters consist of roller or slab mills, as they are sometimes termed, side and face cutters for milling deep grooves and edges of components, and saws—the latter, as their name suggests, cut bars to length or mill narrow saw cuts if these are specified.

Now all these cutters are expensive and though in the engineering workshops there are hundreds of all sizes the amateur rarely has sufficient means to buy more than a very slender nucleus, and these are never used on rough sandy castings or material which is badly scaled.

To secure a range of tools which will enable him to carry out a large number and variety of jobs the model-maker must expand his collection with simple pieces similar to those depicted in the previous article. A cutter made from 3in. of silver steel in the matter of an hour or so is far less expensive than one which may cost several shillings, particularly when the cutter proves difficult to sharpen.

The simple two teeth member illustrated in Fig. 1 has several advantages, and for many workshops it has become the maid of all work. As suggested above, cheapness is most important and as it does not require much skill and effort to make one, even the raw new-

comer can soon learn to file the teeth and secure a tool which will, at least, remove the material, though at the first attempt it may not reproduce a high degree of finish.

make them too slender, otherwise, in common with any other tool, they will break when subjected to anything greater than a very light cut, and as most readers will require them initially to remove the scale from a casting a short stiff cutting member is essential.

Fig. 1 confirms these remarks because the two flats are short, which means they have the maximum amount of strength. Secondly, the width across these flats is maintained as much as possible—a pair of narrow teeth are just as weak as the long variety, hence the reader should keep this point in mind when making them.

A slot is cut across the bottom face, enough to clear the rear edge of the teeth when they

rotation is correct the other member is filed, but this time the cut is the opposite to the first. Failure to make the tool in this manner means that one tooth is cutting while the other merely rubs. Again, it is advisable to look carefully at the drawing and study the different views of these teeth—holding the cutter in an approximate position and turning it about to match the corresponding views.

All this may give the impression the work is complicated and tedious, but this method is one which is practised extensively by tool-makers and draughtsmen alike in their endeavours to avoid an easy mistake. The only way to rectify an error is to adopt what is known as "cutting back" the edges until the faulty teeth no longer exist, and once more filing the angles in the opposite direction, giving the cutter the teeth that will cut when rotated in a right-hand direction.

Side teeth are most necessary or the cutter will rub when any attempt to machine a deep slot is made. Once the front teeth are filed the side are backed off in the same direction, as portrayed by the end view in Fig. 1. An angle of about 10 to 15 deg. is sufficient—enough for the heel to have a rotation radius which is less than the cutter diameter and so avoid a rubbing action.

A "lip" is added to the front face of both teeth, otherwise the cutter, instead of shearing the material in the most efficient manner, simply pushes it away to the detriment of both tools and component. This completes the cutting end of this tool.

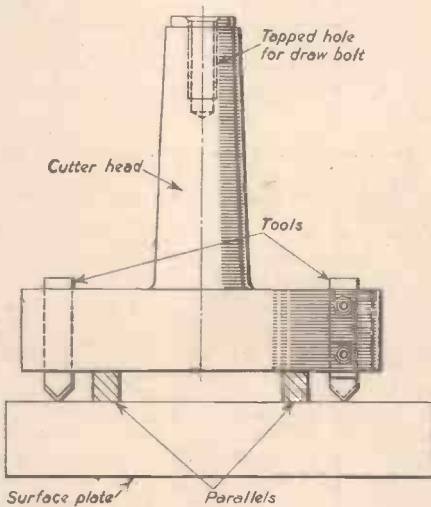

Fig. 2.—A typical fly cutter.

are backed off, the remainder being just discernible in the drawing.

The newcomer to machine work should remember that milling machines rotate in a right-hand direction, thus the way the teeth are produced is obviously important, otherwise it will be found the machine must revolve left hand if the cutting face is to operate correctly. Remember there are two ways of cutting these teeth and make certain the direction of rotation presents the cutting face to the work and not the "heel" of a tooth.

Fig. 1, showing this two-tooth cutter, includes an arrow, which indicates the direction of rotation and it should be noted, in this case, that the direction is anti-clockwise, as seen by looking on the front face. If the tool is turned completely over until this latter face is down on the piece which requires milling, then it will rotate in a right-hand direction.

The easiest way to check this is to imagine a pencil as the cutter, revolve and turn it over; this is described above and in this way errors are usually avoided.

The tool is then clamped in a vice and a fairly coarse file is applied to remove the material from behind the tooth face and so back it off. When one tooth is finished and it is absolutely certain that the direction of

Machining the Shank

The way of machining the shank will differ for various tools because their actual size will have a direct influence on the design. For instance, with tiny cutters, say, 3/16 in. or even less diameter, a parallel shank is usually imparted to it and this provides a good bearing surface when held in the drill chuck.

Larger cutters naturally take deeper cuts with a higher rate of feed, and the pressure imparted to a parallel shank by the jaws of a drill chuck is not sufficient to prevent slipping taking place. Hence the design is modified and a Morse taper added instead. Occasionally it may prove more economical to make the tool with a No. 1 Morse taper and use a Nos. 1 and 2 sleeve to ensure it fits into the lathe headstock spindle, which usually has a No. 2 taper, or alternatively the larger version is provided on the cutter to allow it to fit directly.

A tapped hole in the end to accommodate a long draw bolt is seldom provided, though readers may do so if they wish. This style of cutter is invaluable to the home worker who uses his lathe or milling machine for the machining of such parts as locomotive cylinders and connecting rods; also it has such an excellent swarf space really deep and fast cuts are permissible. Most readers will find it beneficial to make various sizes all together instead of producing single cutters as they are needed, as this saves stopping continually

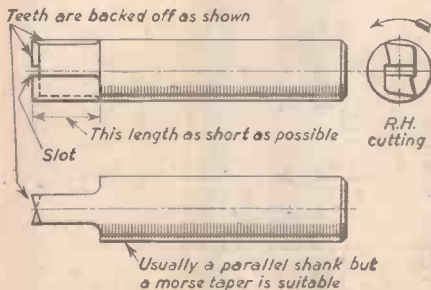

Fig. 1.—A simple two-tooth cutter.

corner can soon learn to file the teeth and secure a tool which will, at least, remove the material, though at the first attempt it may not reproduce a high degree of finish.

Making the Two-tooth Cutter

There are one or two ways of making these cutters; but the crux of the design is not to

to make one for a particular job. Again, if deep cutting is practised it means that one is available for the removal of the rough sandy surfaces and is changed for another prior to taking the final skim to bring the part to size.

Fly Cutters

Fly cutters, to give the next tool, shown in Fig. 2, the correct if somewhat unusual name, are applied when surfaces covering a wide area need machining.

The design is simple and though Morse tapers are sometimes incorporated on the shank, with a draw bolt to avoid any suggestion of the cutter head pulling out and so causing a serious accident, a parallel diameter is occasionally preferred and the three-jaw self-cutting chuck used to hold it securely.

The design relies somewhat on the material available, but the drawing illustrates a typical head in which are mounted a pair of tools, the latter being held by the socket head screws. If a piece of large diameter bar is not available, then improvisation is necessary and this means making the head in two pieces, the shank being a piece of bright mild steel screwed into the flange. A robust bar is essential and it is suggested that the thread is cut without a recess to obviate any weakness at this point. A chamfer in the hole will allow the face to seat properly and the assembled details are the strongest way of constructing this head. It will be appreciated that these cutters, because of their radius of swing, impart a severe shock to the machine spindle, and they must, of course, resist any tendency to bend and break. Incidentally, a shock given to carbide tools will cause them to

fracture, so they are not specified for this type of cutter head. A high-speed steel tool bit is usual and this rarely breaks.

Setting the Tools

For the home workshop both tools are set with their cutting faces in line, and this is quite a simple process.

Stand a pair of parallels on a flat surface, a surface plate, lathe bed, or even a sheet of glass, and place the cutter head in position as indicated in Fig. 2. The tools are then inserted and pushed down gently until their edges contact the flat surface, whereupon the screws are tightened. They should not, of course, protrude too far, so if parallels are used only $\frac{1}{16}$ in. thick this ensures a rigid assembly. Always remember that these tools impart a severe hammering effect on the workpieces which will set up chatter, thus if the cutters are set well back in the head and the latter made of some really stout piece of steel, then these two factors assist in improving the finish, and there is no reason why it should prove inferior to the normal milled face.

Fly cutters are useful in the home workshop for milling gear teeth, keyways, and various other operations which are carried out in the engineering work shops by special machines.

Warning

A word of warning is not out of place in this article. Many accidents have been caused by this type of tool through operators catching their sleeves in the rotating head or receiving a severe blow on the fingers as it rotates. Pull the lathe belt by hand when setting up, and stand well clear when the cut is progressing

across the facing. The chips tend to fly with some force and can easily cause the loss of an eye. The skilled engineer instinctively obeys two "laws" in the factory—never to stand under a suspended load and, if possible, always to stand to the side of anything revolving at high speed!

Sharpening the Tools

The final remarks are devoted to the sharpening of these tools and the cutters which appeared in the previous issue because this work is important. A blunt tool will never cut satisfactorily, and to continue using it for a period after this condition has been reached merely aggravates the trouble, the finish becoming gradually worse. A cutter must cut and not push the material off the bar, and a tool which is frequently "touched up" preserves a keen edge; also it will last much longer than one which may need a $\frac{1}{16}$ in. from the edge or front before it resumes the ideal condition.

Fly cutters are easily reground, using the same technique as applied to lathe tools, but the cutter described for milling the smaller surfaces requires a grinding fixture in order to ensure both teeth are level. "D" bits are ground on the front face and pin cutters are also treated in this manner.

The hardening of fly cutters and mills is carried out in exactly the same way as described in the previous article and if the reader will use $\frac{5}{16}$ in. or $\frac{3}{8}$ in. diameter silver steel and ream the holes in the cutter head he will find the tools fit easily without shake—a factor which ensures they do not move when the cut is applied.

Half-size Pictures on a 35 mm. Camera

By A. D. TEAL

I HAVE recently modified my 35 mm. Retina camera to take pictures half the usual size, the idea being to obtain twice the usual number of colour transparencies, thereby halving the cost. The experiment has proved to be highly successful.

Briefly, I made a removable metal mask which can be pressed into the film aperture and gives the required size of picture, see Fig. 1.

As the film transport mechanism of most 35 mm. cameras is designed to move the film a fixed distance corresponding to the full picture width, it is necessary to pass the film twice through the camera in the following manner.

The cassette is loaded into the camera in the usual way, but two precautions must be taken. First, care must be taken that the film winding sprocket is set at a conspicuous and easily repeatable position; reference to

is placed over the same tooth on the sprocket, see Fig. 2.

This has the effect of moving the film along a distance of four sprocket holes which is equal to half the usual picture width, resulting in the second series of 20 or 30 pictures being placed in between the previous 20.

Using this method, I have consistently produced no fewer than 41 pictures from a colour film with a large saving in cost. The smaller size of transparency projects very well and the definition is scarcely less sharp than using the full frame size.

There are one or two other factors to be taken into consideration, namely the modification to the camera viewfinder and the method of binding and projecting the smaller size of transparency, but these are easily surmounted.



Fig. 3 (Left).—How the transparencies appear on 35 mm. film.

the position of the sprocket retaining screw is a useful guide to this. Secondly, the position of the film, relative to the sprocket is recorded by scratching a mark on the film near the hole which is mated with the sprocket tooth.

Fig. 3 (Left).—How the transparencies appear on 35 mm. film.

Fig. 2 (Right).—Spacing the film for its second run through the camera.

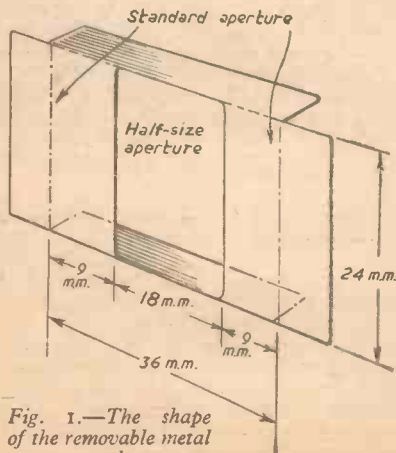
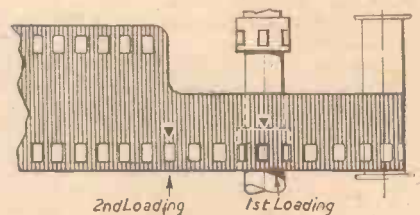

Fig. 1.—The shape of the removable metal mask.

A series of 20 pictures is then taken and the film rewound into the cassette in the usual manner.

If the film was developed at this stage, there would be 20 half-size pictures spaced apart by slightly more than the width of one picture. The next operation is to fill up the blank spaces.

The film is once more loaded into the camera, making sure that the sprocket is in the same position as for the first series of pictures, but this time a hole in the film spaced four holes away from that previously marked,

PRACTICAL TELEVISION CIRCUITS

288 pages, 156 illustrations, 15/- net,
or 15/6 by post from:
BOOK DEPT.,
GEORGE NEWNES LTD., Tower House,
Southampton Street, Strand, W.C.2.

ASTRONOMY



4.—The Three Outermost Planets By E. W. TWINING (Illustrated with drawings by the author)

SO far as we know at present the outermost planets of the solar system, outside that is to say of the orbit of Saturn, are : Uranus, Neptune and Pluto, and they revolve in the order named, Uranus being next to Saturn. Uranus was discovered by the great musician and astronomer, William Herschel, with his very perfect reflecting telescope which he had built himself and which was set up in his garden at Bath. Herschel had had seven years of experience in building telescopes, and using and improving them, and had formed a scheme of examining all stars above a certain magnitude. What his object was we do not know, but he could hardly have

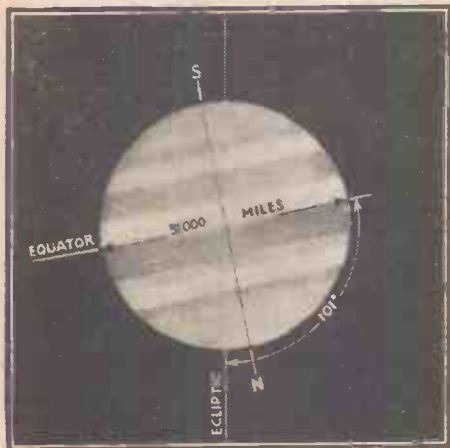

Fig. 1.—The planet Uranus.

anticipated what the result would be. As most, or all, users of a telescope know, no star is ever seen as a disc but always as a point of light ; the point, however bright, will show the colour of a star but nothing more. After examining in this survey many hundreds of stars, Herschel, on March 13th, 1781, was observing in the constellation Gemini ; at length he brought an object into the field of his instrument which differed from all stars ; it presented a tiny but very definite disc. Continued observation, watching the movements of the object night after night, convinced Herschel that it was not a comet, as he had at first thought, but an hitherto unknown planet revolving around the Sun, far beyond the orbit of Saturn and therefore a member of the solar system. Some time, however, elapsed before the true value of Herschel's discovery was recognised, but eventually the size of it and its path and distance became known, and the new planet was given the name Uranus. The five original planets (six, if we include the Earth) had been known from antiquity ; they could all be seen, at suitable seasons, by the unaided eye, but it was now demonstrated that far outside the outermost of these planets there existed yet another body revolving which was far larger than the Earth and was only exceeded in size by Jupiter and by Saturn. So large was it, but yet at a distance so vast, that only on rare and favourable occasions was it possible to see it without telescopic aid.

Dimensions and Details of Uranus

Uranus has a diameter at its equator of

31,700 miles. Its rotation period is $10\frac{3}{4}$ hours and the computation of its orbit shows that its mean distance from the Sun is 1,782,800,000 miles, or twice the distance of Saturn from the Sun. It takes 84 years to make one revolution around its orbit. As a telescopic object the planet is of very little interest except with the largest instruments.

There are four satellites revolving around Uranus, and it is a most extraordinary thing that both the equator of the planet and the orbits of these satellites are so inclined to the ecliptic that the North Pole is below the ecliptic (as I have drawn in Fig. 1), the angle made by the polar axis being, to the ecliptic, only 11 deg. So the satellites have orbits which are nearly at right-angles to the ecliptic and to planes of the orbits of all the satellites of the other planets. It has been suggested that some local disturbance was the cause of this state of things, and undoubtedly this was so, but I think it is unquestionable that the disturbance was set up long before the satellites became bodies separate from the planet ; in other words, it occurred when the whole solar system was in the later nebulous state. I think this because if the disturbance took place after the planet and satellites had cooled sufficiently to become separate bodies, a force acting on the body of Uranus would affect the planet only and leave the satellites revolving on the ecliptic. By a "force" I mean, of course, the effects of impact from some wandering body in space.

The planet had been under observation for many years because it was noticed that Uranus was deviating from the exact path computed for it. When it is remembered that Uranus takes 84 years to travel around its orbit and that it was only discovered in 1781, it will be realised that by the second quarter of the nineteenth century it had only just completed its half revolution and therefore its path was being watched carefully for plotting its orbit. As stated it appeared to be not following its prescribed path, which should, of course, be an ellipse. If a planet were permitted to pursue its course without the interference of any external forces, so that it is guided only by the supreme central attraction of the Sun, then the orbit would be invariable and each circuit of the ecliptic would be performed over the same elliptical path at each revolution. But the positions of Uranus had been plotted by other observers before Herschel's time, who did not know how near they were to making a great discovery. Nevertheless, their records proved invaluable, for by their aid, coupled with observations made after Herschel, the deviations of Uranus were plotted and the amounts of those deviations. It was well known that every one of the planets exercises a disturbing effect on each of the other planets, the amounts of those disturbances depending primarily on the mass of the disturbing body and also, of course, on other circumstances of the movements of each of the other bodies.

The studies of mathematicians have so far perfected the methods of calculating the effects of these forces that they are able to determine how much each planet is forced out of its normal path by the pull of every other planet. So when it was observed that there was such a force, other than those forces set up by the known planets acting on Uranus, astronomers began to seek for the source of

that force. They recognised that the disturbances must be due to the attraction of some other unknown planet. This gave rise to one of the greatest intellectual problems which the mind of man has ever solved. The task of finding the source of the disturbing factor was taken up by two astronomers, not by visual searching of the heavens but by mathematical calculation. One of these was Leverrier, in France, and the other, Professor Adams, in England. Each pursued his investigations quite independently of the other and both at last came to the same conclusion : that it was possible to determine the whereabouts of the unknown planet from calculations based on the behaviour of Uranus. It is most remarkable that the two investigators should have concurred, not only in determining the track of the unknown planet, but even in ascertaining the very point in the heavens which the disturbing body occupied.

The Discovery of Neptune

Leverrier at last felt so confident that the new planet could be seen that on September 18th, 1846, he wrote to Dr. Galle, astronomer at the Berlin observatory, and requested him to direct his telescope to a particular point in declination and right ascension and there he would view a planet which no human eye had previously seen. Dr. Galle was able to comply with Leverrier's request on the very day the letter was received, with the result that Leverrier's forecast was verified and the planet was seen in the field of the telescope.

Meanwhile, it appears Professor Adams had completed his calculations and had, like Leverrier, provided detailed instructions for finding the planet ; there was, unfortunately,

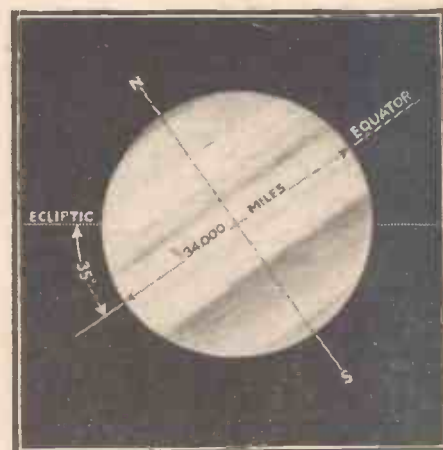

Fig. 2.—The planet Neptune.

some delay due to the absence of star charts before Professor Challis, of Cambridge Observatory, could commence his search, which search was at once successful. Although the new planet was actually seen first by Dr. Galle before being observed by Professor Challis, it was eventually found that Adams's calculations were completed earlier than those of Leverrier, and so it was decided that the honour of discovery of the planet, to which the name Neptune was given, should be shared equally between them.

Neptune revolves at a mean distance of 2,794,000,000 miles from the Sun, its equatorial diameter is 34,000 miles, so that it is a little larger than Uranus, and it takes no less than 165 years to make one revolution around its orbit. It has one known satellite which is visible only in large telescopes. There is nothing abnormal about the angle of inclination of the polar axis to the ecliptic as there is

in the case of Uranus. The angle is given in Fig. 2.

Pluto

Twenty-four years ago, that is to say, in the year 1930, a still more distant planet was discovered. This was Pluto, which is much smaller than either Uranus or Neptune and probably smaller than our Earth. The finding of this was the result of research which had

been constantly going on to find whether the limits had been reached for the solar system. Pluto is so distant that it is unlikely that any more can be discovered, even though they exist, for its period around the Sun is 249 years and it presents a disc so small that its diameter cannot be measured. Its distance from the Sun is so variable and its path so eccentric that its orbit at times comes within the orbit of Neptune.

Home-made Snowshoes

Be Prepared for Snow this Year and Have Your Own Snowshoes Ready

THERE is a great deal of enjoyment to be had from snowshoeing, and if you have your snowshoes ready you may begin to gain experience with the first reasonably heavy fall of the coming winter. You can make your own shoes without a great deal of trouble or expense.

The framework of the snowshoe should be made of one piece of wood bent to the required shape, so that the first job will be to make the bed on which this shaping can be accomplished. Obtain a strong piece of board 3ft. 6in. long by 16in., or a little larger.

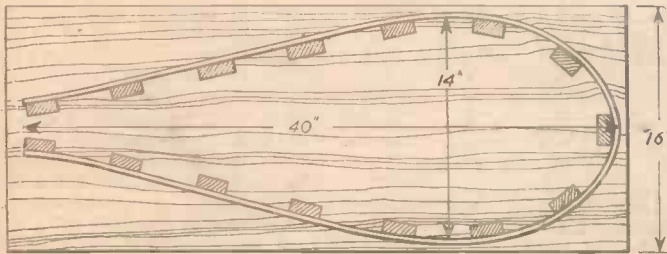

Fig. 1.—The shaping bed for the snowshoe frame.

This can be made of two or more pieces joined together side by side by crosspieces nailed underneath—three widths of floor-board serve very well.

On this flat board blocks must be nailed to the desired shape, round which your framework will eventually be bent. Each block should be about the size of a matchbox and at least 1in. thick (see Fig. 1).

The Frames

Prepare two strips of ash, each $\frac{1}{2}$ in. or $\frac{3}{4}$ in. square and 7ft. to 8ft. long—the exact length may be found by stretching a tape measure round the blocks. See that this ash has good straight grain and is free from all flaws. It should be planed square and smooth.

Now it is necessary to bend these strips into shape. Do one at a time, starting from the middle, which will form the toe of your snowshoe, and wrapping round steaming cloths until the ash becomes pliable. As you bring the strip tight against each block of the board, drive a nail against the outer edge so that it remains firmly in its place. When your first strip is in position treat the second in exactly the same way, fixing it round on top of the first.

At this stage you will need to wait a week for the framework to set; the shape will be spoiled if it is taken from the board too soon.

When you do remove it you should begin by fastening the two ends of the snowshoe together, nailing the strips to the narrow block between them, which must taper so that it fits exactly. Alternatively, you may put a bolt and nut right through.

Fitting the Wood Strips

These are as shown in Fig. 2. The three

narrow pieces are 1in. wide and of the same thickness as the outer frame. They are fastened by screws, and together form the toe hole. The front crosspiece should be 7in. from the front of the snowshoe, and the rectangular hole is 5in. by 8in. The broader crosspiece is of the same material, but must be 4in. wide; the heel will rest on it when the snowshoe is in use. Take care that all these crosspieces are very strongly fixed, for they not only will have to take your weight but they must prevent the outer framework from warping or losing its shape.

Covering the Snowshoe

The most easily obtained material suitable for the purpose is that sort of metal gauze which is used for the sides and doors of small meat safes. An ironmonger will supply it. Cut your gauze to the desired shape, so that it covers the whole of the snowshoe except the toe hole, and lap the edges over the framework, securing it with big-headed tacks or nails at frequent intervals. Alternatively, you may cover the edge with a thin strip of wood or light metal, thus covering the gauze and making a neater finish. The gauze will, of course, lap over the inner edges of the toe hole in the same way.

The Straps

The snowshoe is now complete, except for two straps. One of these passes across the middle of the toe hole, so that when the boot is resting on the snowshoe it goes over the instep, allowing the shoe to be lifted. The other, which is best fitted with a buckle, is secured at the two back corners of the toe hole; these straps go round the ankle.

Give the snowshoes one or two coats of varnish to finish them off and they are ready for use.

Walking on Snowshoes

The first time you put them on in the snow they will feel exceedingly clumsy, but it will not take long to get the knack of using them. You walk on snowshoes, you do not glide as on skis. The chief trouble at the outset will be due to their size. It will be found necessary to lift each foot rather higher than in ordinary walking and to swing it forward still lifted, so that the snowshoe goes over the top of the one on which your weight is resting. The inner edges thus overlap while the step is being taken. The raised foot must also be held slightly out to the side, so that the edge of the snowshoe

clears the other ankle as it passes. Then, if you put it down as you would in ordinary walking, the rear of your snowshoe will almost certainly go down on the front of its fellow, and to avoid this trouble you will need to take fairly long steps—if you happen to be a tall person your normal strides may be enough. In addition, you may help matters by turning your toes in slightly, for that will make the heels of your snowshoes slant outwards and so lie clear.

A good deal of the preliminary work in acquiring these "snowshoe strides" may be done at home before the snow actually comes and you will thus probably be able to experience the pleasure of padding along comfortably on the first day of snow.

One of the most important features of the snowshoe is the toe hole. Without it it would be very difficult to make progress, for your feet would slip back almost as fast as you put them forward.

Only the heel of your boot, however, rests on the framework, held in place by the heel strap. Thus as you go forward on to the other foot the sole of your boot goes down through the toe hole and sinks into the snow, acting as a brake which prevents you from slipping backwards. If you notice how your weight goes on to your toe in ordinary walking you will see how each sole in turn must become almost vertical before it is lifted, and thus it obtains a strong pressure on the snow. As you lift your snowshoe the instep rises through the toe hole and catches against the front strap.

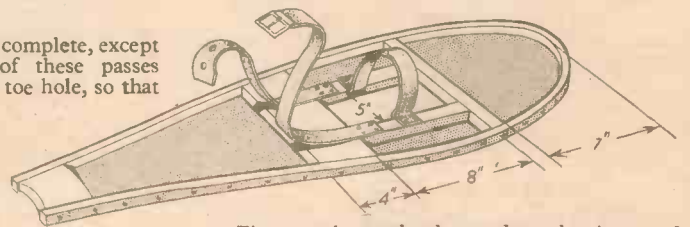

Fig. 2.—A completed snowshoe, showing wood strips and straps.

Walking Up Slopes

For this it will be advisable to carry a long stick, or perhaps one in each hand, to help you along in the same manner that a skier does. A steep slope should be ascended by zigzags, so that the gradient is lessened. Much more use will be made also of the toe hole, for naturally the foot will need to sink through much farther in order to obtain the necessary grip. In coming down a hill you will simply amble along comfortably, scarcely using your toe holes.

Always dry your snowshoes thoroughly after use, and keep them reasonably clean; but do not dry them in front of a fire or you may warp the framework. It will be sufficient to stand them on their ends against a wall in some dry corner. Wipe the straps also and keep them supple with grease.

A Visitor from Mars

A Review of the Latest Book on Flying Saucers

By F. J. CAMM

THE latest contribution on the subject of flying saucers is "Flying Saucer from Mars: The Facts,"* presented by Cedric Allingham. It is not a piece of science fiction but offered as a statement of fact, and we are thus entitled to examine the claims made by the author very closely indeed. We are told that the author is "no mystic, but a trained scientific observer with considerable astronomical knowledge." No details, however, are given as to his qualifications in support of this claim. The gravamen of his book is that in February, 1954, he saw a flying saucer land in North Scotland, and not only photographed it from close range, but made direct contact with its occupant, who indicated that he came from the planet Mars. We are further informed that Mr. Allingham's description is fully confirmed by an independent witness, James Duncan. The blurb on the jacket says that the book has not been written as a sensational story, but as a sober, scientific document (so was the story of the Loch Ness monster!) and that it contains a selection of the author's "remarkable and hitherto unpublished photographs."

The photographs (two of which are here reproduced) are on a par with all the other

photographs which have been published by Adamski and others; foggy, out of focus, lacking in detail, and without any background. It seems a pity that all of those who have written books claiming to have seen and photographed flying saucers are such poor photographers. No one has yet photographed a flying saucer, claimed to have landed, against any background of hills or houses or trees. These visitors from Venus

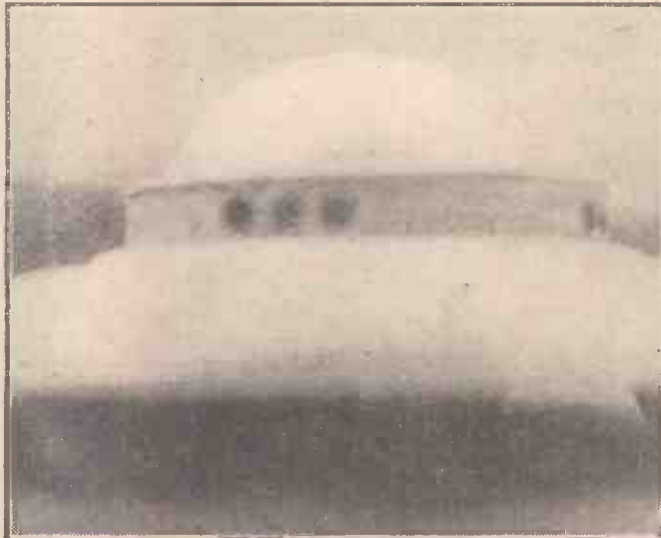

The Martian's "Space Ship."



Mr. Allingham's photograph of the "Martian."

and Mars always arrive in outlandish spots, for no apparent reason, and no one seems to have photographed them entering or leaving their space craft. The photographs are always muzzy and unconvincing. Mr. Allingham's book does nothing to remove the doubts which undoubtedly exist in the open minds of scientific people.

Out of this book of 143 pages, less than 40 are devoted to description of the author's claim to have interviewed and photographed a visitor from another planet. His description belies the claim of the publishers that he is a trained scientific observer. In the first place, why did not Mr. Allingham consider this intruder from another planet as an invader, and take steps either to arrest him, to inform the police, to photograph him entering his ship, and to produce a photograph of the ship against the background of the lonely part of Scotland where, he claimed, it landed.

He adopted the Adamski formula for conveying his questions to the visitor from Mars; he pointed to the sky and assumed "a questioning attitude . . . Reached for my pad and scrawled a diagram on it. In the middle I put the sun, starrng it with rays . . . round it I drew three circles to represent the orbits of Mercury, Venus and the Earth. I pointed to the third circle and then to myself and he nodded. I pointed to the second circle . . . he shook his head. I pointed again and said the word 'Venus.' He repeated after me 'Venus'

. . . outside the orbit of the earth I drew a fourth circle to represent the orbit of Mars. I pointed to it, then turned to him and said 'Mars.' He nodded at once." Earlier we are told that as Mr. Allingham neared the saucer "a sliding panel in the lower part moved back, and a man leaped lightly and gracefully to the ground. As he advanced to meet me I raised my arm in salute, he did the same." After a description of the man and his voice Allingham proceeds to question the man, by cabalistic signs. He asked him where he came from, why he had come, and endeavoured to indicate his friendliness by presenting him with his fountain pen. There is a lot more of this sort of inane questioning, and Mr. Allingham, "could not understand his words," but "his gestures were clear enough. He was asking me whether the people of this earth were about to start another war." Mr. Allingham shrugged his shoulders, shook his head, and tried to give the impression that he hoped there would be no war. The Martian "seemed to understand" and for a moment his face looked serious and troubled. Are we seriously expected to believe that a messenger from Mars would undertake the hazardous journey from that far distant planet, in order to land in a remote part of Scotland, on the off chance of meeting someone like Mr. Allingham on a bird watching expedition, to find out whether we were going to embark on another war? Surely a race so advanced that they can build space ships and land on the earth would not rely upon such a casual and unscientific method. I reproduce a photograph taken by Mr. Allingham of the Martian as he was leaving to re-enter his ship. Why not a face view? Why not a view of him actually stepping into the plane with a background of the landscape? Notice the photograph also reproduced of the space ship—incomplete, fuzzy, and lacking in background. Mr. Allingham excuses himself on this score by stating that he is a poor photographer and that his camera is a cheap one. In support of his interview, the author publishes a facsimile of a signed document by "James Duncan" which was written on a leaf of the author's notebook. Mr. Duncan witnessed the descent of the saucer and the author's conversation with its occupant. The address of Mr. James Duncan is not given. The bulk of this book is a recapitulation of Adamski's claims and a brief historical survey of sighting of space ships.

* "Flying Saucers From Mars," by Cedric Allingham. Published by Frederick Muller, 10s. 6d.

THE saw bench about to be described has given very satisfactory service for several years. It contains a number of features not usually found on this type of equipment, but it is not made to tilt. The idea of a tilting table was abandoned in favour of solidity and simplicity of construction. The main features are a large table and accurate and easy control of depth of saw cut.

For making the saw bench no special materials (with the exception of saw spindle and plumber blocks) are required. The main body is made from standard section angle iron and the table top from heavy gauge galvanised sheet iron.

Description

The saw bench has been so designed that it can be used either as a self-contained unit on its own stand or as a fixture in the workshop. As a movable unit, its usefulness is greatly extended, as it can be taken outside the workshop and work undertaken which would be impossible inside.

The complete machine consists of four principal parts, see Figs. 1 and 2.

1. The table and height adjusting screw.
2. The frame to which is attached the table and which carries the saw and spindle.
3. The stand which is bolted to the frame



Making a Saw

Constructional Details of a Special Features

and which carries the platform for the 1/4 h.p. electric motor.

4. The motor, 3-pin socket and switch.

The table is hinged to the frame at the rear by two 1/4 in. bolts and the rise and fall is controlled by a 1/4 in. Whit. bolt, threaded for 8 of its 9 in. of length, and locked by two hand nuts through the front of the frame. The motor is situated beneath the frame and protected from sawdust by suitable shields.

Before any construction is undertaken, the saw spindle, 1 1/4 in. dia. pulley, and plumber blocks should be obtained. This is advisable as the dimensions of part of the frame depend on the height and width of the plumber blocks. The distance between the bolt holes will determine the position of the supporting bars and, incidentally, the path which the belt will have to take.

The height of the plumber blocks will also control the height of the upright parts of the frame, marked X in Fig. 6. The table

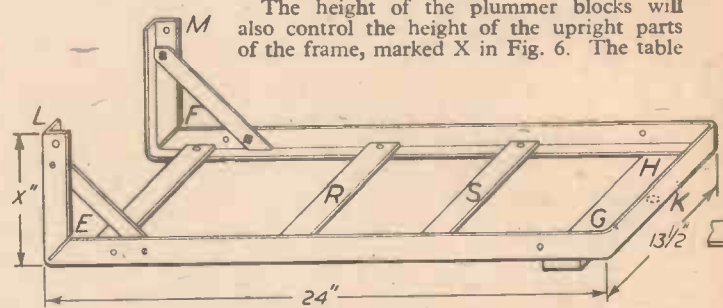
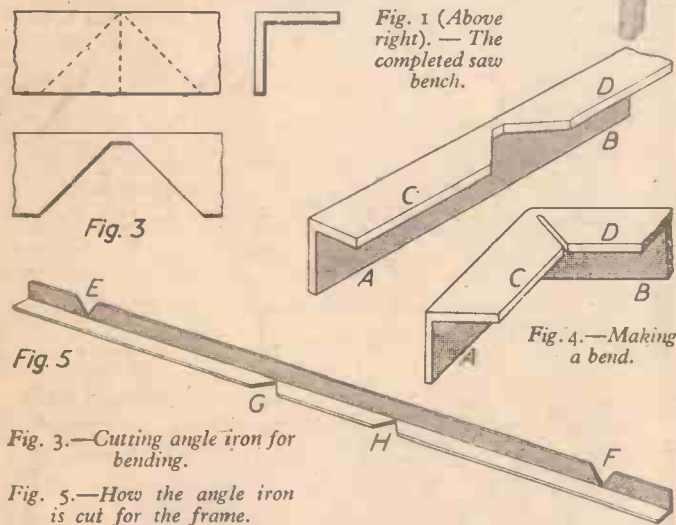

Fig. 3.—Cutting angle iron for bending.

Fig. 5.—How the angle iron is cut for the frame.

Fig. 4.—Making a bend.

Fig. 6.—Constructional details of the frame. Note that the cuts for E and F are not on the same face of the iron as cuts G and H.

should be parallel with the frame when rim of the 6 in. saw is above the table.

Construction

All the measurements are given as a guide, and they can be modified to suit individual requirements or to fit material in hand. Unless otherwise stated, 1/4 in. bolts are used for bolting up, their positions being, in most cases, perfectly obvious. Drawings are not to scale.

As the main construction is of angle iron, bent in a number of places, a detailed description of the method of bending will be given.

Draw a line at right angles across the angle iron at the place where the bend is to be made; with this line as centre, draw two more lines, one on each side at an angle of 45 deg. Saw along these lines and remove the triangle of iron, Fig. 3. The iron is now heated at this point, the part marked A, Fig. 4, placed in the vice, and part B bent round to form a right angle, Fig. 4. Care must be taken when making the bend to ensure that the inner edges C and D do not dip; this is tested with a straight edge across the angle. The iron can be bent cold, but it is much more difficult to line up the top flats.



Fig. 11.—The bolt in a small

The Frame

The construction of the frame should be undertaken first as the size of the table depends on it.

A piece of 1 1/4 in. x 1/4 in. angle iron is cut as in Fig. 5 and bent as in Fig. 6. It will be noted that the upturned parts E and F are not on the same face of the iron as cuts G and H. Three pieces of flat iron,

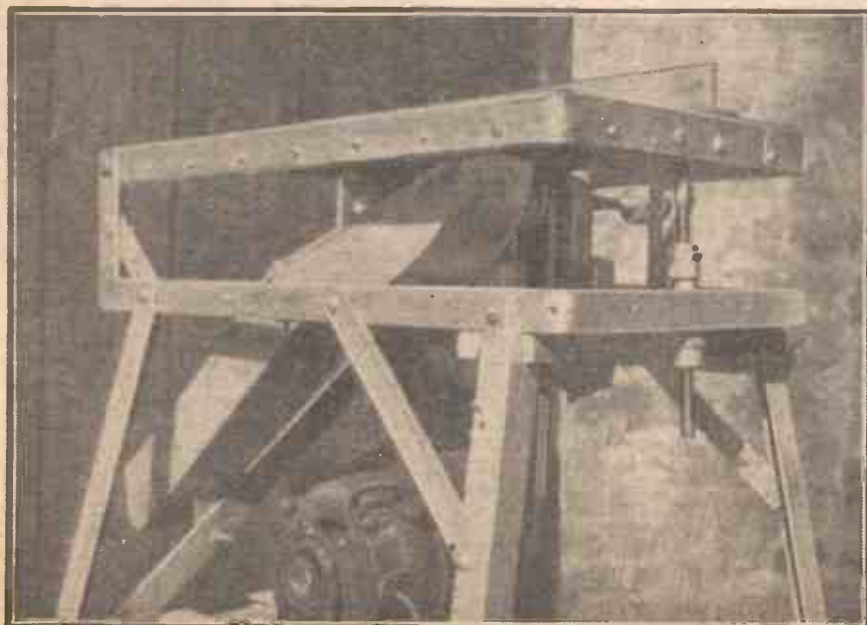

Fig. 16.—A view of the completed bench showing a duct for removing sawdust.

Fig.

Bench

Versatile Unit with Many
By W. E. RICKARDS

1½ in. × ½ in., are cut to fit across the frame. The frame is then squared up, and the cross-member from E to F bolted into position. The two other pieces should be set aside for the time being. Two short pieces are cut and fixed across the angles E and F. A ¼ in. hole is made in the middle of the front at K, to take the adjusting bolt. A suitable piece of wood is bolted across the underside, from G to H; this is to carry the switch when wiring up. This completes the work on the frame for the time being.

The Table

The table framework is made from 1½ in. × ½ in. angle iron, as Fig. 7. It must be just wide enough to fit between the uprights on the frame. Its length must be such that when it is

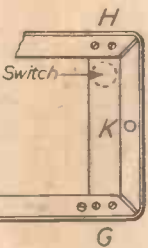

Fig. 8 (Right).—The galvanised sheet iron table top.

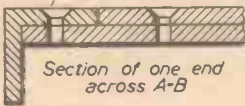
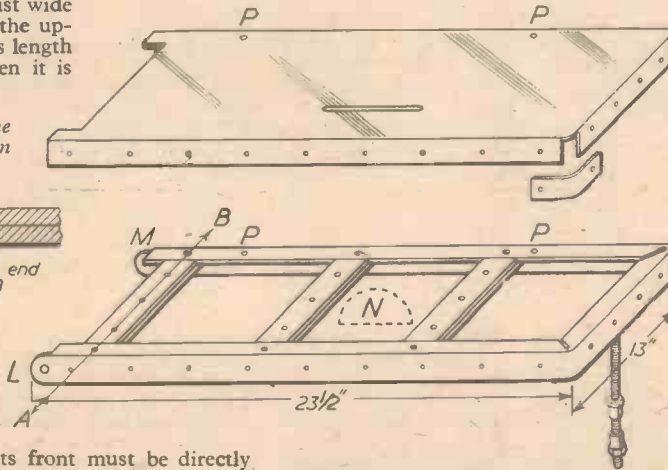

Fig. 7 (Right).—Constructional details of the table framework. The insert is a section across one end, showing method of countersinking.



bolted in position its front must be directly over the front of the frame, when they are parallel. The cross-members are each made up of two pieces, thus bringing the top face to one level. The ultimate position of the saw is shown at N.

Table Height Adjusting Screw

This is fixed in the centre of the front and should be made next, but not finally bolted into position till the table top has been fitted. Two methods of construction are shown in Figs. 9 and 10. In Fig. 9, a short piece of ¼ in. rod is welded across the end of a bolt to form a T and held in place by two brackets bolted as shown. The other (Fig. 10) is a round headed ¼ in. bolt, with the head filed to the shape shown, and fixed by a clip, Z. Whichever fitting is used it must allow the bolt to move in a small arc, to follow the varying angle made by the table. Fig. 11 makes this quite clear. Two knurled nuts are needed, one to adjust the height of the table and the other to lock it in place. A piece of ¼ in. bore tube, 1½ in. long for a distance piece to clear the

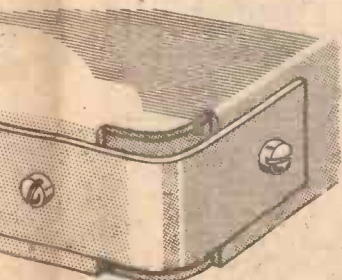

12.—How the front corners are strapped.



Fig. 2.—A perspective view of the completed saw bench.

angle iron, Fig. 15. Slight adjustment of the hole at K, Fig. 6, may be needed.

The Table Top.

A piece of heavy gauge galvanized sheet iron is now obtained. It should be quite flat and without dents, and should be about 1½ in. wider all round than the table frame. It should be marked and bent to fit snugly round the angle iron. The corners at the front are cut away and strapped as in Fig. 12. The sides are fixed with round headed 3/16 in. bolts. Before the top is finally bolted into place it should be tested for flatness. If any curvature is found, it can usually be taken out by careful bending and fixed down by a countersunk bolt at the most convenient point. The top can now be fixed in position. The sheet iron at the rear is bent down and under, and held in place by countersunk bolts in the holes already drilled in cross piece A, B, Fig. 7. The method of countersinking used on the table is shown in Fig. 7. The saw slit should be left till later.

Temporarily bolt the table to the frame by the hinge bolts L and M, Figs. 6 and 7.

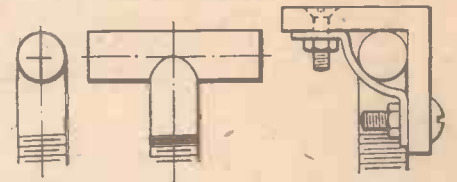

Fig. 9.—One type of height adjusting screw.

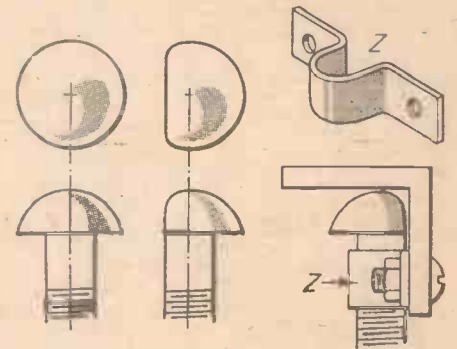

Fig. 10.—An alternative form of height adjusting screw.

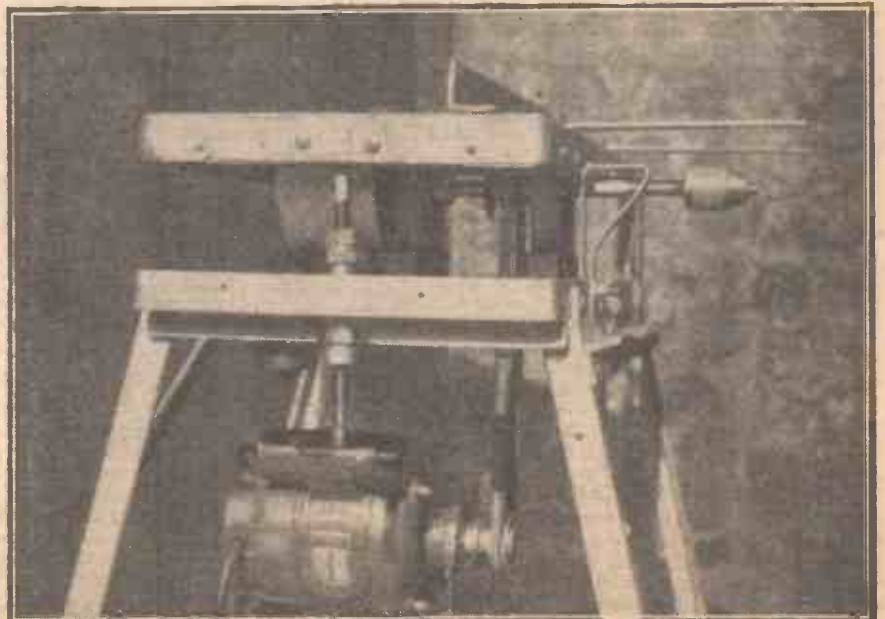

Fig. 17.—A view from the front of the completed saw bench.

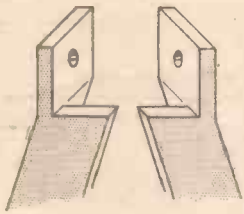

Fig. 13.—How the tops of the legs are cut.

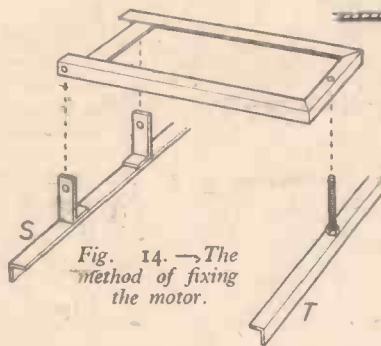

Fig. 14.—The method of fixing the motor.

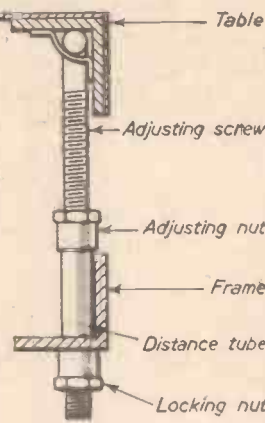

Fig. 15.—The table height adjusting screw.

Saw Slit in Table

Replace the table in position and carefully lower until the saw is almost touching, mark and once more remove the table. Accurately punch mark the ends, which should be 5 7/8 in. apart for a 6 in. saw. Drill 1/4 in. holes at punch marks and cut along the line between the two holes. The edges have now to be turned back underneath to form a slit 5 7/8 in. long x 1/4 in. wide.

Before fixing the table permanently in position, drill and tap 5/16 in. Whit., two holes in the positions shown in Fig. 7 (P). These are for the fence fixing bolts.

Having replaced table, lower till the saw is at maximum height above the surface. It must now be tested to see that it is at right angles to the table. If a slight error is present, it can be corrected by packing pieces placed under the appropriate ends of the plummer block supporting bars.

The Fence

This is made from 1 1/2 in. x 1/2 in. angle iron, and is the full length of the table. Two slotted guides are made and riveted to the fence. The slots should be wide enough to allow the 5/16 in. bolts to slide freely the whole length. If a line, in the exact line of the saw, is scribed on the table top, it will facilitate the setting of the fence.

Wiring the Motor

The switch is located on the under side of the wooden bar fixed across the frame (Fig. 6). All the wiring is brought out to the 3-pin socket, not forgetting the earth wire.

A considerable amount of patience and hard work is needed to construct this machine, but it will be amply justified in the results obtained. Two additional views of the completed unit are shown in the photographs, Figs. 16 and 17.

Make sure that the table is square to the frame and that it is moved smoothly by the adjusting screw. If everything is satisfactory, remove the table and proceed to construct and fit the stand.

The Stand

Four legs (about 2ft. 9in. long) of 1 1/2 in. angle iron are used. These are made in two pairs, cut and bent as shown in Fig. 13. These are fixed to the frame, braced as shown in Fig. 1. The cross pieces are angle iron at the front and rear, and flat iron at the sides. The height and position of the bars will depend upon the type of frame used to support the motor.

Motor Carrier

A neat adjustable method of fixing the motor is shown in Fig. 14. This works on the same principle as the table, being hinged at the back and adjusted at the front by a 1/2 in. bolt. A piece of wood is bolted across the rear of this frame to carry the 3-pin socket.

Fitting the Saw Spindle

Everything has now been completed,

except the fixing of the saw assembly and cutting the saw slit in the table. The accuracy of the machine depends upon the correct alignment and adjustment of these parts. The spindle must be set to run at right angles to the sides of the frame (and, of course, the table) and should be midway between front and back. The saw itself should be about 5 in. from the left-hand side when viewed from the front. The plummer blocks are bolted to the cross bars R and S, Fig. 6. The bars are in turn fixed to the frame. The path of the belt from motor to spindle should be considered at this point; it will run either between the two bars, or will straddle one. When the path of the belt has been determined it will give plummer block, bars and motor positions. When all has been set up, check again the alignment of the spindle and, if correct, bolt all parts into position.



"All you have to do is to trim the machine to a glide when you are about 50ft. to 100ft. above the ground, pull back the throttle and the machine puts itself into the right attitude and alights, just as though it were an ordinary human being capable of taking action without reference to anybody else."

First Alarm Clock

IT is believed that the first alarm clock was invented in 427 B.C. by Plato, who fitted a siphon to a water clock (clepsydra) and used it to summon his pupils in the morning. As soon as the water was levelled with the top of the siphon, it ran down a tube into a vessel below so quickly that the air in it was compressed and escaped through a pipe with a loud whistle.

The octagonal tower of a water clock built in the last century B.C. still stands in Athens. There are many examples of house water clocks in this country. They are comparatively simple to construct.

Earth "Much Older" Than Was Thought

RECENT studies of radioactive factors in lead ores have indicated that the earth is much older than was previously thought. The latest figure puts its age about 4,200,000,000 years.

Water Boiled by Sun in TV Test

A SOLAR cooker of a type which is being sold in parts of India for about £5 was shown in a television programme recently. It took 25 minutes to boil a pint of water, and in India a cup of rice can be cooked in a pint and a half of water in about 20 minutes.

In countries where fuel is scarce the cooker may make a real contribution.

About 5,000 are being made every month in India. They consist of a concave aluminium mirror tilted to the sun. Food is placed in a

double-walled pot on a stand in the focus point.

Life on Mars

DR. E. C. SLIPHER is an astronomer at America's Lowell Observatory. He has just returned from South Africa after taking 20,000 photographs of Mars through a 27 in. telescope.

He reports that on Mars polar caps gleam white, frost areas appear, and clouds and dust-storms swirl.

There are at least two new canals. Some areas grow and shrink with the seasons. Judging from broad, intensely coloured markings, last year must have been very good and fertile.

It is doubtful whether Mars has any animal life, on account of lack of oxygen and water. The life there is presumably similar to lichen.

Many Inventions

THE Exposition D'Automne is an annual Paris exhibition of home appliances, etc., and each year an inventors' competition is held. This year's inventions include an extensible knitting needle, a luminous watch with the smallest known lamp fitted to it, and a micro-projector that will enlarge images up to 1,500 diameters thrown on a screen.

Tin-zinc Electroplate

THE Tin Research Institute, in the course of its research, has invented a new alloy plating which is effective in preventing the rusting and corrosion of steel.

This new plating is an alloy of 75 per cent. tin and 25 per cent. zinc. It combines the advantages of tin with those of zinc. Tin-zinc alloy plating is being adopted on aircraft, motor car and motor cycle parts, radio and television chassis and loud speakers, and refrigerator freezing units.

Training in Submarine Escape Procedure

A TANK 100ft. deep, built into a tower and containing 700 tons of water, is in use at H.M.S. *Dolphin*, the Admiralty Submarine Training School at Gosport, for training crews in the latest methods of escape from submarines. New submarines will be fitted with a one-man escape chamber at each end, from which members of the crew will ascend one at a time by what is called "free ascent," no breathing apparatus being worn.

Operating within the tank is a form of diving bell by means of which instructors can be lowered to any of the levels from which trainees begin their ascents to the surface, or can rapidly attain any depth at which a swimmer may be in difficulties. Glass portholes enable the bell to be used as an underwater observation platform. Observation is also possible from the top of the tank.

The diving bell takes the form of an inverted open-ended hemisphere some 4 1/2 ft. in diameter with a platform about 4 1/4 ft. below on which the instructor stands with his head and shoulders within the air trapped in the bell.

Bomber Solves Landing Problem

THE Handley Page "crescent wing" Victor bomber solves the problem of bad-weather landing, claims the aircraft firm, by landing itself automatically.

"The Victor has characteristics which will appeal to every pilot who has ever had the job of landing in fog," says the firm's bulletin.

Making a model of the

P.S. WESTWARD-HO

Full Constructional Details of a 4ft. Long Scale Model of a Paddle Steamer Powered by Diagonal Steam Engines

2.—Building the Power Unit

By "DESIGNER"

THE power installation consists of four-items: the boiler, the fuel supply, the engines and the paddles. All of them are shown in the general arrangement drawing (Fig. 6). For the sake of clarity all measurements have been omitted, but a scale has been given from which, with a pair of dividers, the reader can take off his own measurements. Many references will have to be made to this drawing so it will be well to handle it carefully and not to indent it or tear it with the divider points.

The Cylinders

I recommend the making of the cylinders for a start and Fig. 7 is a drawing of one of them. There are two and they are of opposite hands, one right and one left. I have shown the left, but apart from being opposite handed

they are exactly alike, so that precisely similar castings can be used for both; it only means that the cylinder covers will be put on opposite ends in one casting from the other and in the valve chest the steam admission opening will be drilled the opposite way.

The cylinders are bored for a $\frac{7}{16}$ in. diameter piston and the stroke is $\frac{1}{2}$ in. The thickness of the piston is $\frac{1}{4}$ in., so the length of the bore is $\frac{3}{4}$ in., which makes allowance for end clearance and the depth of the spigots of the cylinder covers. It will be advisable in order to put a fine finish on the cylinder walls to lap them with metal polish on a brass rod turned to make a perfect sliding fit in the $\frac{7}{16}$ in. bores. The pistons can be a nice sliding fit also and the semicircular grooves filled by winding in them, not too tightly, strands of soft cotton wick impregnated with

grease. Sufficient must be wound on to make it press and make perfect contact all around against the cylinder bore and then slide with gentle pressure on the piston or its rod.

The ports are drilled $\frac{1}{16}$ in., two holes for each port; they measure $\frac{5}{16}$ in. overall, horizontally, on the valve face, and the valve has a lap of a little under $\frac{1}{64}$ in. The travel of the valves is $\frac{1}{4}$ in. full. These slide valves are each built up of four pieces of metal soldered together and must be ground with metal polish down on the true and flat port faces, on which they have to slide and make steamtight contact. They are driven by bent steel plates which make sliding fits over their ends. In these plates the threaded valve spindles are screwed. This screwing provides the means whereby the positions of the valves over the ports are adjusted. By uncoupling

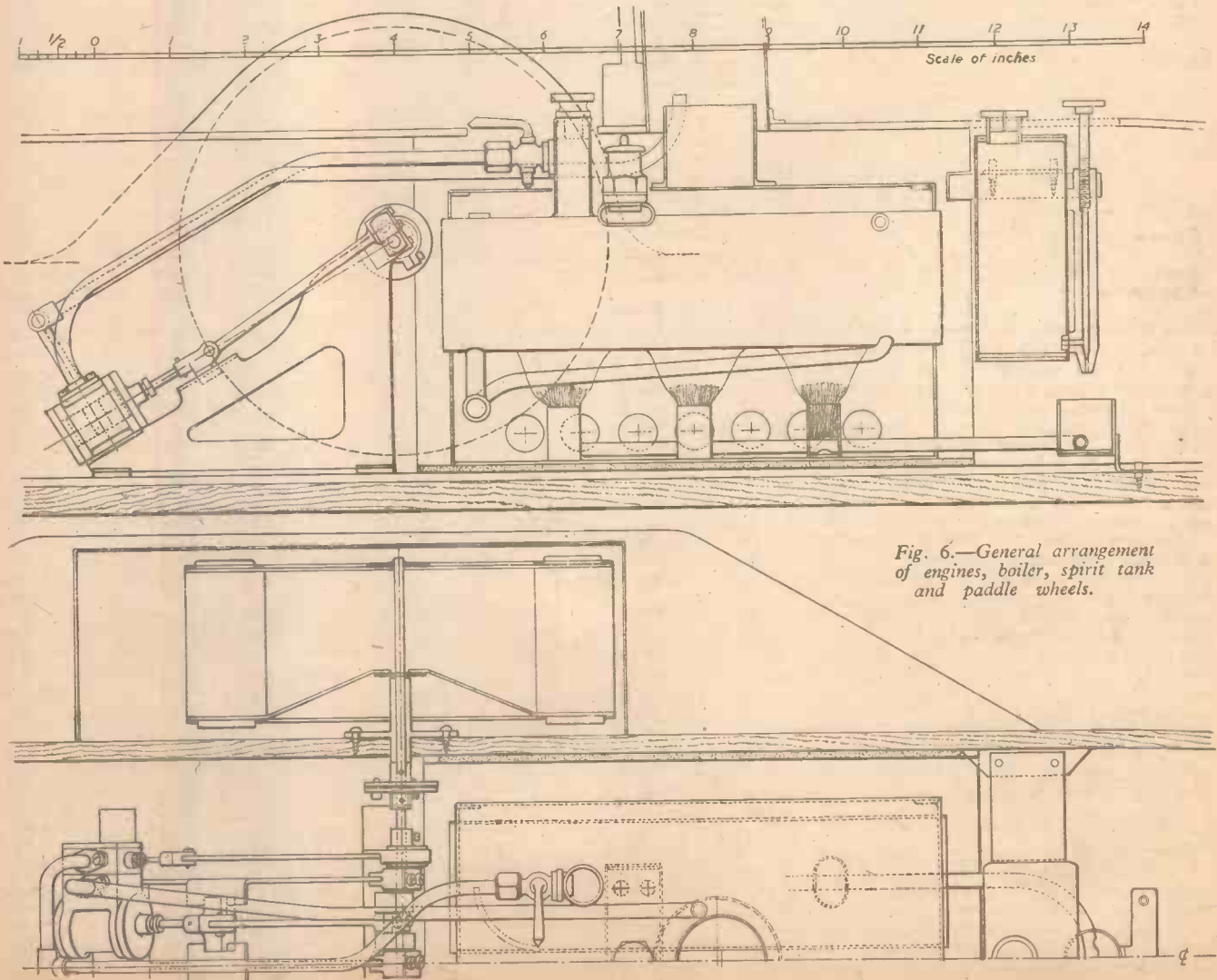
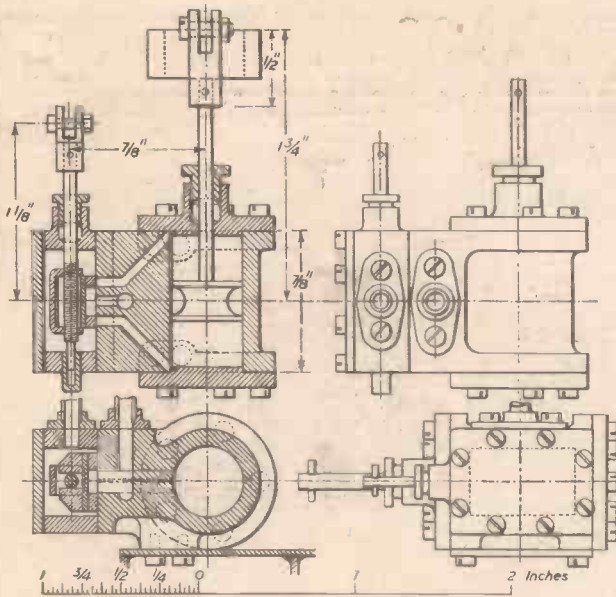

Fig. 6.—General arrangement of engines, boiler, spirit tank and paddle wheels.



can be cut away, the ends of the crank pins filed flush with crank webs and the whole polished bright. On each end of the shaft a brass coupling plate is fitted, pinned to the shaft as shown, tapered pins being used.

In addition to the cranked shaft Fig. 9 shows one connecting rod, with piston and one of the eccentric rods. The sheave of the eccentric is drilled for a throw of a full 1/16 in., which will give a travel to the valve of 9/64 in.

The Boiler

This is of the shell and water tube type. It used to be known as the Smithies type, after its designer, who invented it over 50 years

ago specially for models. There are two shells, two sets of water tubes and two rows of burners in our model vessel. I believe Mr. Smithies applied the type originally to locomotives, when, of course, there was only one shell and a greater number of tubes.

In our present model the two boilers have to be connected together; this is done at two main places: at the bottom or lowest point of the water tube system and at the top or steam space. The principle of the boiler is that rapid circulation of the water takes place and consequently rapid evaporation. There are two down-coming tubes, one from each shell, both entering a large cross-tube. From this cross-tube two pairs of water tubes, all rising upward, pass through the flames of the spirit burners and enter the boiler shells at the forward ends, two tubes into each shell, all as shown in the general arrangement, Fig. 6, so the water is kept in circulation and in the water tubes turned into steam. Both the shells are of the same length, namely, 6 3/8 in., and both are exactly alike except for the large upstanding pipe on the left-hand one (which is on the port side of the vessel). This pipe has a filler cap, screwed into a collar soldered at its

(Continued on page 125)

the eccentric rods the valve spindles can be revolved in the required direction. This setting of the valves is, of course, best done with the valve chest cover removed, so that the opening and closing of both front and back ports can be seen and corrected. The valves must open and close the ports, both back and front, for admission of steam and cut off, at both ends of the piston stroke equally.

The crossheads are secured to the piston and valve rods with tapered pins, the tapers in the holes being obtained by a fine broach and on the pins with a fine file in the lathe.

The Engine Frames

These are shown complete in Fig. 8. They should be cut from brass sheet of about No. 18 s.w.g. and the three must be pierced and filed up together so that all are exactly alike. The operation is facilitated if the plates are tacked together with solder as a measure against movement. They may be either silver soldered to all the crossplates or they may be soft soldered. In the drawing they are shown as silver soldered. If soft solder is used the joints will have to be reinforced with little lengths of angle brass at every point where the frames are connected to the crossplates, because the soft solder on the edges of the frames alone would not give sufficient strength. But the three main bearings, in view of the fact that they are forked to receive the frames, can very well be soft soldered. It would be as well to drill and finish these bearings, pass a straight piece of 3/4 in. diameter steel rod through all three, see that the rod is square with the frames in all directions and, with the rod still through them, complete the soldering between them and the frames.

The main piston-rod crossheads are also shown in Fig. 8, but these call for no special comment beyond pointing out that the slots on either side must be of such a width that they make a good sliding fit on the guide plates.

The Cranked Shaft

Fig. 9 shows the complete cranked shaft; this is made from a true and straight steel rod 3/4 in. diameter. There are four crank webs made from steel and the two pairs must be at exactly right angles one with the other. These are to be silver soldered to the shaft. Have the crank pins in place at the same time; then do all the silver soldering of pins and shaft at one operation. The right-hand crank is shown leading, but it does not matter which leads. The shaft must be left as one piece 4 1/4 in. long until all is soldered up, and then the pieces of shaft between the crank webs

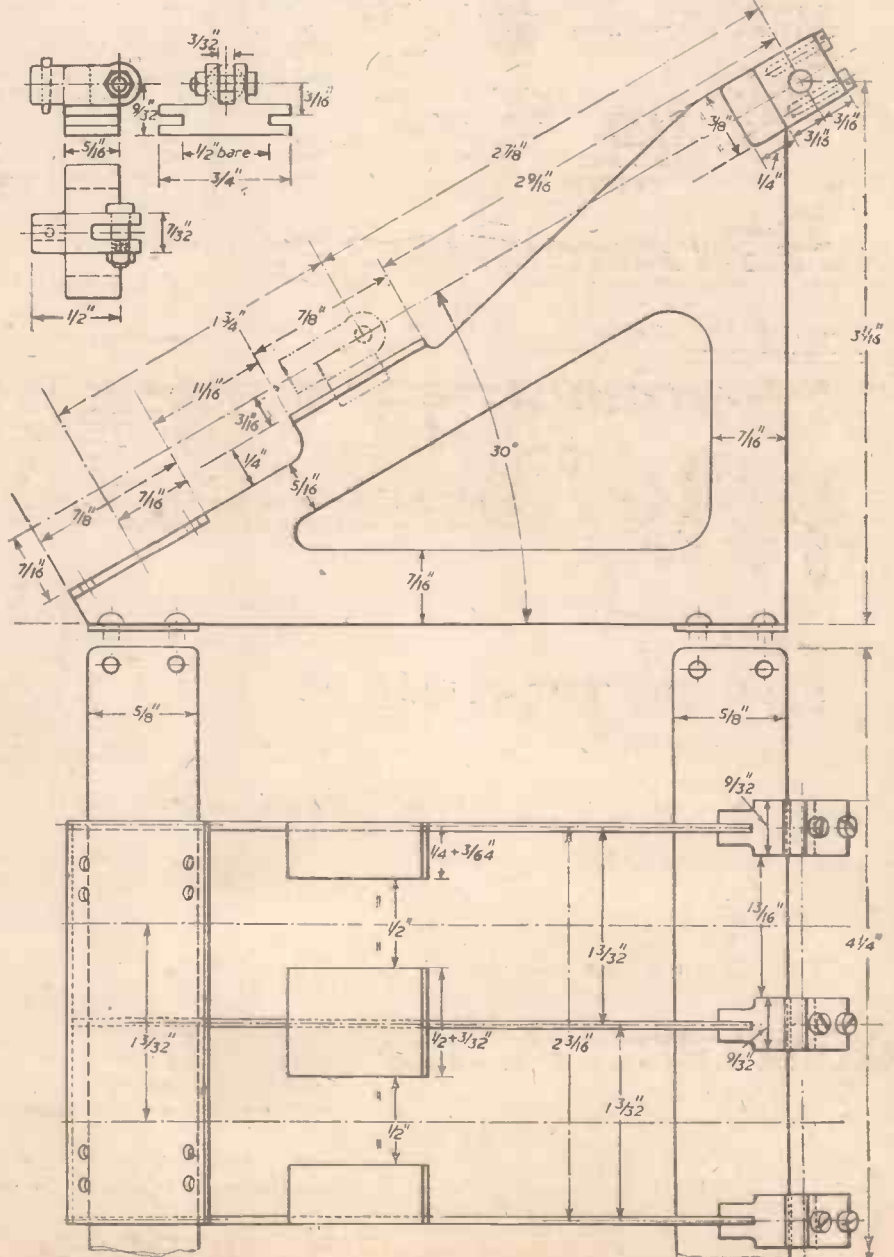

Fig. 8.—The engine frames with main bearings; also main crossheads.

"Baker's"

Regd

SOLDERING FLUID



QUICK · CLEAN · CERTAIN · ECONOMICAL

PRODUCT OF SIR Wm. BURNETT & CO. (Chemicals) LTD.
GREAT WEST ROAD · ISLEWORTH · MIDDLESEX · ENGLAND

Send Now for New Brochure detailing all points and interesting features; answered questions you would ask, showing machines in use and articles such as toys, patterns and turnery made on these machines. Ask also for details of fittings to the "Coronet" range and other makes. Is long hole drilling a problem to you? Send now for details of BORING ATTACHMENT and long drills, to suit any lathes.

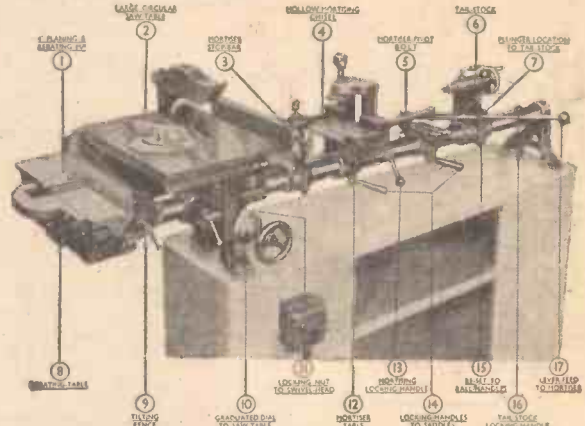

FITMENTS AND ACCESSORIES FOR ALL LATHES :

- CUP CENTRE No. 1 Morse Taper Shank.
- 4 Prong DRIVING CENTRE (Positive Drive for large or small work).
- GRINDING WHEEL ARBOR No. 1 Morse Taper—suit any machine with No. 1 Morse Taper.
- REVOLVING CENTRE.
- 5" WOBBLE SAW—Ploughs $\frac{1}{8}$ " to $\frac{1}{4}$ ". Index for quick setting and fine adjustment.
- TURNING TOOLS, set of six 18" overall, beautifully handled.
- WOODSCREW CHUCK to suit any machine No. 1 or 2 Morse.
- 3 Jaw CHUCK and Self Centering 4 jaw Independent Chuck.
- COMPOUND SLIDEREST—for wood and metal turning.
- ELECTRIC MOTORS, Brook $\frac{1}{2}$ and $\frac{1}{4}$ h.p.
- GRINDING WHEELS, SLIPTONES, etc.

Write: Dept. P.M., enclosing stamp, for Catalogues showing photographs and price, etc.

CORONET TOOL CO. 8, MANSFIELD ROAD, DERBY
Also at CITY ROAD MILLS, DERBY.

NEW!

RADIO & T.V. OUTFITS

LEARN THE PRACTICAL WAY

Specially prepared sets of radio parts (which you receive upon enrolment) with which we teach you, in your own home, the working of fundamental electronic circuits and bring you easily to the point when you can construct and service radio sets. Whether you are a student for an examination; starting a new hobby; intent upon a career in industry; or running your own business — these Practical Courses are intended for YOU — and may be yours at very moderate cost.

EASY TERMS FROM 15/- A MONTH



EXPERIMENTAL OUTFITS:

- BEGINNER'S RADIO OUTFITS**—A course in basic principles.
- ADVANCED RADIO OUTFITS**—Instruction and equipment from which you build a Radio Receiver.
- TELEVISION**—Instruction and equipment for building a Television Receiver.
- Also for Mechanics, Electricity, Chemistry, Photography, Carpentry, Draughtsmanship, Commercial Art, Amateur S.W. Radio, Languages.

All lessons and equipment supplied immediately and becomes your own property

POST THIS COUPON TODAY

Please send me your FREE book on Practical Courses.
To: E.M.I. INSTITUTES, Dept. No. 144, Grove Park Road, London, W.4.

NAME.....

ADDRESS.....

SUBJECT(S)..... IC.37

DEC.

E.M.I. INSTITUTES The only Postal College which is part of a world-wide Industrial Organisation

A VERSATILE ELECTRIC DRILL TOOL.

Quarter inch, made by BLACK & DECKER, 220/250 volt, A.C./D.C. Domestic or power.



YOURS FOR 27/6 DEPOSIT.

CASH PRICE **£5.19.6** Post & Pkg. 2/6 (with cash or deposit)

ELECTRIC SURFACE GRINDER



For removing rust, preparing woodwork, buffing, burnishing, polishing. 220/250v. A.C./D.C. Domestic or power.

YOURS FOR 37/6 DEPOSIT

Balance over 6 months CASH PRICE **£8.7.6** Post & Pkg. 2/6 (with cash or deposit)

1 AMP. BATTERY CHARGERS



Also useful as Eliminator. New and fully guaranteed in leading maker's original carton. 200-250v. A.C. With Warning Indicator Light. Charges 6v. and 12v. batteries & maintains 1 amp. output at both voltages. List price 95/- **52/6**

Also 2 AMP. DE LUXE MODEL WITH AMMETER **89/6** (Usually 126/6). Carr. 1Pkg. 2/9.

GENUINE NEW and PERFECT EX-GOVT. SIGNAL LAMPS

Adaptable as Workshop Spotlight For day or night use, 3 1/2 in. lamp. Morse key, view finder, mirror, reflector, fully wired in strong waterproof case. Swivel base metal screw-in stand. Complete with spare parts, tin and coloured discs. Includes Map Reading Lamp. Free Morse Code Leaf. Post and packing 2/3. Spare bulbs 2/6.

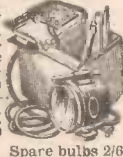

15/- SECURES DELIVERY OF GOODS VALUE £3 Larger Amounts Pro Rata. Balance payable over 6 months.

SEND FOR FREE ILLUSTRATED CATALOGUE **PRIDE & CLARKE Ltd.** (Dept. P.M.) 158, STOCKWELL ROAD, LONDON, S.W.9 BRI 6251

MAIL ORDER BARGAINS

EX-GOVT. MOTORS

A.C./D.C. mains, 3,000 R.P.M., 1 1/2 in. dia. with blower & gearbox to 30 R.P.M. P. & P. 2/6.



SPECIAL OFFER 1- of DISPENSING SCALES, lacquered brass, capacity 2 oz., all well-known makes in excellent condition, totally enclosed in own polished teak box. Original Price £7/10/-, our price whilst stocks last, 35/- (post free).



EX-GOVT. CONTROL PANEL with on/off switch with 45 ohm variable resistance. 2 amps. suitable for train sets and charging controls. Offered at a fraction of original cost. 8/6 each.

BRAND NEW SOLENOID VALVE 24 volts, D.C., 12/6 each. P. & P. paid. P.P. free on orders over £2.

Please Print Name and Address when ordering. SEND WITH CONFIDENCE FOR GOODS. MONEY BACK GUARANTEE. CASH WITH ORDER.

C.O.D. and 'Phone Orders Accepted. **UNIVERSAL TRADERS (PM4)**, 44, LONDON RD., TWICKENHAM, MIDDLESEX. POPesgrove 6040.

WIRING ACCESSORIES

All goods are of a well known manufacture and carry a money back guarantee. All cables are manufactured to the latest British Standard Specification. **CABLE**—TRS Flat Twin, 1.044, 49/4; 3.029, 62/4; 7.029, 104/10. PVC Sheathed Flat Twin, 1.044, 43/-; 3.029, 91/10. All per 100 yds. Our PVC cables are suitable for interior or exterior use and may even be buried in concrete. All types and sizes of cables available in 25, 50 or 100 yd. lengths. Heavy cables cut to desired length at no extra charge. **Switches**, 1/6; 2-way, 2/-; Ceiling Roses, 10d.; Lampholders, 9d.; 3-pin Sw. Sockets, 5A, 4/11; 15A, 7/6; G.O.D. or C.W.O. All carriage paid. It will pay you to get our complete lists.

HUNT & CO., WEST STREET, EXETER. Phone: Exeter 58887.

Prices slashed at Clydesdale

DISTRIBUTION BOARDS 250 volts, 15 amp. 3 way

a "Simplex" iron clad 15 amp. Distribution Board with 6 rewirable fuses, highly efficient fuse unit mounted on hinged battens and fireproof fillet between poles. Size: 8in.L x 6in.B x 3 1/2in.D. Wgt. 8 lbs. Ask for A/H949 "Sandalite Duplex," similar, but with no fillet. Overall size: 8in.L x 8 1/2in.B x 4in.D. Wgt. 13 lbs. Ask for A/H950 M.E.M. "Kantark," similar, but with no fillet. Overall size: 8in.L x 7in.B x 3 1/2in.D. Wgt. 8 lbs. Ask for A/H951 All unused but slightly marked externally due to being stacked. 6/6 each. **SPECIAL QUOTATION FOR QUANTITIES.** Post paid. **BRASS GLANDS**, 1in. diam. In three lengths, 1in., 1 1/4in., 1 1/2in. Bore 1in. Price 1/3 each. Post paid.

ENGINE DRIVEN GENERATOR

Type KX Ref. 5U/190 In Manufacturer's Carton. 24 volts, 1,500 watts (Rotation Clockwise), spined spindle: dia. 1in., projects 1in., overall size 14in. x 8 1/2in. Wgt. 27 lbs. 4 hole fixing. Speed, 3,500-5,000 r.p.m. Ask for A/H880 **£3.15.0d.** each Carriage Paid.

DIRECT CURRENT GENERATOR

Type 3D3G Ref. 42U/506 Output 14/32 v. 9 amps. 2,500 r.p.m. 1in. dia. spined spindle 1in. projection. Size: 11in. x 7in. x 6in. Wgt. 31 lbs. Can be used as a battery charger or low voltage lighting generator, when driven by a motor or petrol engine. Ask for A/H837 **£2.19.6d.** each Carriage Paid.

ROTARY PUMP, 24 v. D.C. 2.5 amps.

Ref. 5U/2492 1 1/2 in. bore inlet, 1in. bore outlet, 4 1/2 in. flange for connecting to tanks. Ideal for pumping oil, petrol, water, etc. Diecast construction with brass rotor blades. Dim.: 4 1/2 in. x 7in. x 7 1/2 in. Wgt. 5 lbs. Ask for A/H944 **35/-** each Post Paid.

SUITABLE AS UNIVERSAL ELECTRIC MOTORS

For 200-250 v. A.C. or D.C. mains. By simple external wiring, full data supplied. New method gives better than 1/6th h.p. with M.G.29, or approx. 1 h.p. with M.G.30.

MOTOR GENERATOR TYPE 29 As generator. Input 24 v. 16 a. Output 1,200 v., 200 ma. Dim.: 11in. x 5 1/2in. x 5 1/2in. Ask for A/E880 **17/6** each Carriage Paid.

MOTOR GENERATOR TYPE 30 Ref. 10K/21. Input 9.3 v. 23 a. Output 7.2 v. 13 amp., 255 volts. 110 ma. Size: 12in. x 5 1/2in. x 5in. Ask for A/H488 **15/-** each Carriage Paid.

EX. U.S.N. TEST OSCILLATOR TS-24/ARR2

Low/High frequency, battery powered for TBX alignment, H.F. signal 245 mc. L.F. signal tunable 540 to 830 Kcs. with valves 2-955 acorn triodes and time-switch with calibrated dial. Unit Dim.: 9 1/2in. x 7 1/2in. Finish Black. Ask for A/H364 **27/6** each Carriage Paid. Circuit 1/3.

HAND OPERATED WOBBLE PUMP R98, BC-1444

Reciprocating action provides a suction and exhaust action to each stroke. Designed to pump hydraulic oil to a maximum reservoir pressure of 750 lbs. per square inch. This pump is capable of drawing water from approximately 5ft. below its own level, and exhausting same to a height of 4ft. above its own level, at a rate of 60 strokes per quart. Inlet and outlet threaded nozzles fitted at one end of the unit. Suspension arms and rams fitted at the other end. Length of Pumping handle 27 1/2 in. Length of pump overall 8in. Height of pump overall 4in. Ask for A/H568 **12/6** each Post Paid.

Order direct from: **CLYDESDALE SUPPLY CO. LTD.** 2, BRIDGE STREET GLASGOW C.5 Phone: South 2706/9

'MARLCO' KNURLING TOOL

Range 0-4in. All steel, case-hardened. Can be assembled to operate in front or behind work. Will exert great pressure without strain to light lathe. Floating jaws will follow workpiece and enable knurling to be started in its middle. Diamond and straight cut knurls available. Full particulars on request.

W. H. MARLEY & CO., LTD., Eng. T Dept., New Southgate Works, 105 High Rd., London, N.11. Telephone: ENTerprise 5234/5578

Bridges OF LONDON

FOR TOOL POWER THE POWER TOOLS THAT *speed the job*

IF IT'S POWER TOOLS—IT'S BRIDGES

1/4" TOOL POWER GENERAL PURPOSE DRILL This is it! Bridges newest drill with twice the power and 4 times the life of any other drill in its class! Faster penetration, easier handling, bags of guts. Like all 'Tool Power' tools it's built to last a lifetime.

S. N. BRIDGES & CO. LTD., BRIDGES PLACE, PARSONS GREEN LANE, S.W.6 (REN 1477/9)

Here is the LESDIX

Latest CRYSTAL SET



A Valveless Receiver, in attractive brown plastic case, 6 in. x 5in. x 2in., fitted with tapped 1 1/2z wound aerial coil for long and short aerial variable condenser, germanium diode detector, phone transformer, plug and sockets for aerial and earth connections. Complete with headphones with headband cord and plug, 30/-, post 2/6.

MORSE PRACTICE SETS comprising A.M. morse key twin coil buzzer, terminals and space for battery on pol. wood base. 7/6, post 1/6, or complete with single phone, fitted headband and cord, 10/-, post 1/6.

MORSE KEYS, Small practice key on base, 2/6, post 9d. Air Ministry type precision key on base with back and front contacts 5/-, post 9d. Practice buzzers in bakelite case, 3/6, post 6d. Twin coil A.M. buzzers, 5/-, post 9d.

MICROPHONES, The G.P.O. hand mike carbon insert in moulded bakelite case, 4/6 each, post 1/-, Mic-buttons 1in. dia. carbon granules with mica diaphragm, 2/6, post 6d. Transformer for either type, 2/6, post 9d.

TERRY ANGLEPOISE LAMPS for drawing Boards or Workshop, stay in any position, for wall or machine fixing with S.H.C. Lamp holder, shade and flex, 35/-, post 2/6.

TRANSFORMERS, 230 volts tapped input 270-0-270 volts 6.3 volts 2 amps, 5 volts 2 amps output, 14/-, post 2/-, 230 volts input 12 volts 8 amps output, 30/-, post 2/6.

MULTI-CORE FLEX, New 6-way P.V.C. coloured flex with metal screen and P.V.C. overall, fully tropical, 2/- per yd., post 6d. 88 per 100 yds., carr. extra.

ROTARY CONVERTERS, 24 volts D.C. input, 230 volts A.C. 50 cycles 200 watts output, £15, carr. extra. 110 volts D.C. input, 230 volts A.C. 50 cycles output 200 watts, £15, carr. extra. 24 volts D.C. input, 230 volts A.C. 100 watts output, 90/-, carr. 7/6.

ELECTRADIX RADIOS

Dept. H, 214, Queenstown Road, London, S.W. Telephone: MACaulay 2159

20 CIRCUITS for 2/6 only

Our Super-Handbook, "The Home Constructor" with its supplementary incorporates

- *20 CIRCUITS—Superhets, T.R.F. Sets, Amplifiers, Feeder Units.
- *SUPERHETS—Full constructional details, supra-simplified diagrams and point-to-point wiring.
- *COIL PACK—Full constructional details for a superhet coil pack.
- *CAR RADIO—Full constructional details.
- *RADIO GEN—Pages of information, Resistance Colour Code, Formulae, and "know-how".
- *RADIO CONTROL—Supplement with theoreticals.
- *RADIOGRAM Supplement.
- *INFORMATION LETTERS—The latest issues of our popular Information Letters.
- *CATALOGUE—Profusely illustrated catalogue and price list.

"The most helpful book in the Trade." SEND FOR A COPY TO-DAY

SUPACOILS (Dept. M.12) 21 Markhouse Road, London, E.17

Jubilee The Finest Clip in the World

Make SURE it's a genuine Jubilee!

JUBILEE

L. ROBINSON & CO. (GILLINGHAM) LTD. London Chambers, GILLINGHAM, KENT. Phone 5282

upper end, by means of which the boiler is filled with water. The pipe serves to a great extent as a dome, for from near the top the steam to the engines is taken.

The cross connecting of the steam spaces is achieved by means of a flattened tube, which, with its ends sealed with tiny plates, is filed to saddle on to the two boiler shells, which are both pierced with holes in order to give free steam communication between the two shells. On the centre of this tube, and on the centre-line of the vessel, the safety valve is mounted. As shown in Fig. 6 this valve should come under the box, at the foot of the funnel, on which the pipe on the after side of the funnel is mounted. For the full-size vessel this pipe carries off steam from the safety valves. The model safety valve and filler plug, with their respective collars, and also the union cock for the main steam supply to the engines, have been selected from the catalogue of Messrs. Bassett-Lowke, Ltd.

Beside the water cross tube and the steam saddled tube two more cross stays should be fitted between the boilers; one of these is a tube, for the sake of lightness, and the other just a flat strip of brass at the extreme after end. Both are shown in Fig. 6. Neither of them enters the boiler; they are merely stays to stiffen up the structure.

The casing of the boiler is made up of thin

to build up the rest of the tube structure: the down-flow tubes, the cross-water tube and the four water-circulating and evaporating tubes. The safety valve collar should be silver soldered, but the filler-cap collar and the steamcock collar may be soft soldered if

spirit burners, the spirit tank and the drip-feed supply. The fuel is methylated spirit. The burners are of slightly flattened brass tubes filled with wicks made from asbestos string. They are arranged in two rows 2in. apart, and each burner is separated a distance of 1in.

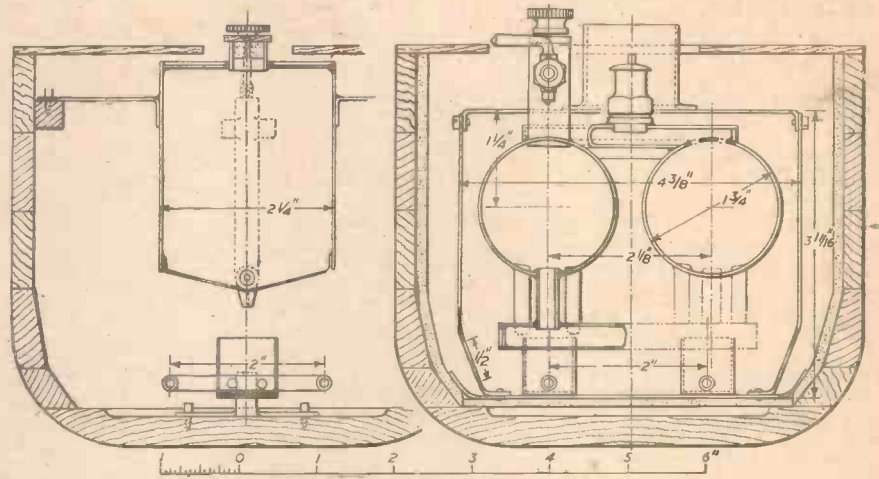

Fig. 10.—Cross section of the boiler and fuel supply.

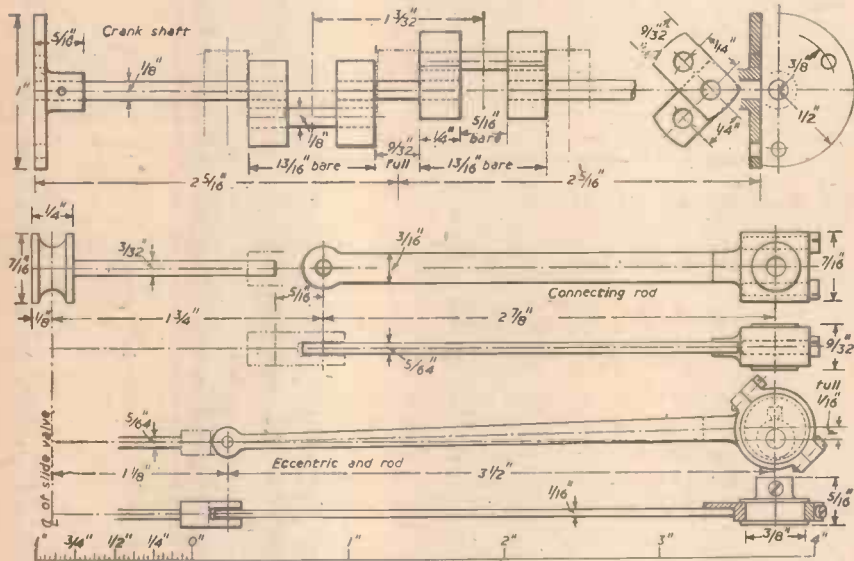

Fig. 9.—The complete cranked shaft.

iron or steel plates of about No. 22 s.w.g. The cross-sectional view of the boiler on the right-hand side of Fig. 10 clearly shows the form of this. The bottom plate is bent upward on each side to fit on to the asbestos lining of the hull, and the side plates are riveted to it. The top plate is flanged, pierced for the steam dome pipe, safety valve and inner funnel and the front and back plates have circular openings, 1 3/4 in. diameter and 2 1/2 in. apart to receive and support the boiler shells.

Soldering Up

Now I think it is imperative that the whole boiler shall be silver soldered together, not soft soldered, in order to guard against the risk of it running dry and fusing the solder by overheating. Therefore, after the end plates, which can be Bassett-Lowke castings, are silver soldered in their places the casing should be made, the shells fitted into the end plates of this and, whilst they are so held, with the top of the casing omitted, the steam cross tube and the two stays silver soldered to the shells. By this means there will be rigid fixings between the two boilers, which will ensure their fitting again into the casing after all the tubes, etc., have been added. Next proceed

desired. These are outside of the casing, but the dome pipe must be silver soldered into the boiler. The side plates of the casing will each have seven 1/2 in. holes cut through them where shown and the back plate about five 3/8 in. holes, quite low down. The front plate will have two rectangular openings measuring each 1 1/2 in. high from the bottom plate by 1 in. wide. The centres of these will be 2 in. apart and through them the burners and their wicks will have to pass.

Pressure Gauge Location

It will be noticed that no pressure gauge on the boiler has been shown. Although a gauge is not necessary for safety, as bursting pressure is far above that at which the safety valve would blow off, it is not possible to set the valve for any predetermined pressure without a gauge, and, in this connection, a working pressure of 30 or 40 lb./sq. in. will be ample. Therefore it would be desirable to fit a gauge, and in that case let its dial be horizontal and be seen through a hole in the deck on the opposite side to the steam dome. From the dome the pipe to the gauge can be taken.

The Fuel Supply

Taken together Figs. 9, 6 and 10 show the

from the next. Each burner has the fuel pipe passing through it and this pipe is drilled at each burner for the egress of spirit. The fuel pipe is continuous for both rows of burners and where it passes through the drip-feed receptacle, which is circular and 3/4 in. in diameter, the fuel pipe is drilled on the bend with two or three holes to admit the spirit to the pipe. No part of this fuel system is fastened down in the hull; to keep the burners in position there are two screws, without heads, passing into the bottom of the hull and over these screws there is a plate with an upturned angle, the upturn being soldered to the drip receptacle.

The same arrangement for detachability is made for the main spirit tank; here the screws are inserted into little wooden blocks glued to the sides of the hull. All the foregoing is embodied in both the plan and elevation in Fig. 6 as well as in Fig. 10.

The tank can be made of tinplate, soft soldered together. The drip-feed valve is turned, drilled and tapped in brass rod with a boss silver soldered on near the bottom. This boss is drilled into the bore of the valve. The bore will be of two diameters: a long one with a diameter of a full 1/2 in. and, at the bottom, a short one of about 3/64 in. On the shoulder formed by the difference the needle valve will make its seating. The upper end of the larger bore is tapped with a No. 4 B.A. thread and the needle valve screwed with the same. There will be a knurled wheel at the top of the valve, just above the deck level, for regulating the valve opening.

For filling the tank there is a tube in its top of about 7/16 in. or 1/2 in. diameter soldered into the tank; this has its upper end closed by a cork, on the top of which a small disc of plywood is glued. A tiny hole must be bored through the disc and the cork for the admission of air.

The size of the flames for generating the required pressure and quantity of steam in the boiler can be regulated by the lengths of wicks projecting from the burners and by the rate of drip of the spirit through the needle valve. When the correct adjustment of the valve opening is arrived at it would be advisable to mark an arrow or put some form of pointer on the milled wheel of the valve and a corresponding mark on the deck, so that the same amount of valve opening can be obtained every time that steam is raised.

(To be continued)



Letters to the Editor

The Editor Does not Necessarily Agree with the Views of his Correspondents

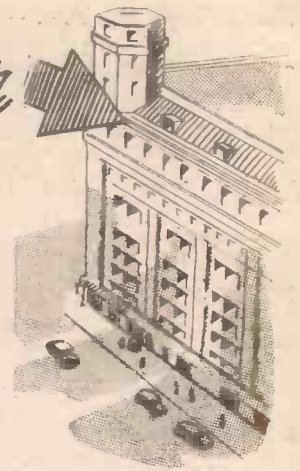

Astronomy

SIR,—That Mr. Twining has considerable knowledge of astronomy is very evident

from his article on the moon; but surely the theory of meteorite bombardment causing the craters has been thrashed out, down to its every possible detail. Practically every book on the subject goes into the theory very completely. So much can be said against it that one wonders where to start.

To dismiss the volcanic and bubble theories by saying "Where has the gas, steam and water gone to?" (which in effect he does) shows a lack of knowledge somewhere. It is quite probable that we have got it. Gravity is so low on the moon that it could not hold it for any real length of time. The weight of the moon proves that it is considerably more porous than the earth. So it could easily be composed of large hollows.

It is considered that we are very slowly losing atmosphere; how much more must the moon lose when the gravity is only one-sixth of the earth! The meteorite theory ignores the heat of the collision of a huge piece of matter about 100 miles in diameter with the moon. Such a collision would be certain to create sufficient heat to melt all the surrounding country. There would hardly be any steep walls. The crater in Mexico shows the shape of a meteorite caused crater. This is very "dish-like," or perhaps "saucer-like" would be a better description.

It is only lately that domes or maybe unburst bubbles have been seen on the moon. These domes sometimes have a small hole in the middle. This surely shows volcanic action and bubbles.

The furrow he mentions near the crater Plato is, I think, obviously a crack. Of which there are a very large number. In fact, I am rather surprised he hasn't mentioned them.

The quiet volcanos of Hawaii (Mauna Loa and Kilauea) resemble the moon's craters in every possible respect, Kilauea even having the central cone.

There are plenty of other theories of how the craters came but too long to be the subject of a letter. One thing is very obvious, and that is the large craters came first as there are signs of the molten material bursting through the walls and flowing down outside. But I don't think there are any signs of this happening to the small craters. The overlapping does, I admit, show bombardment, but the same thing happens in the bowl of porridge.

Much can be said for both sides, but the one great thing in favour of volcanic action is the steep sides of the walls. This does not happen with a bombardment. And it surely would be too much to say that immediately after the collision the surface froze into the shape it now has. I don't know what the heat of such a collision would be, but it would be tremendous and probably take a long time to cool. During which time subsidence must have taken place.—C. V. THOMPSON (London, W.14).

SIR,—I note that Mr. Twining would like to see a photograph of the "Great Bear Spiral" (I assume he means M101) showing stellar images, and would refer him to the centre page of the Harvard College

Observatory, U.S.A., November, 1953, edition of the *Sky and Telescope*, where he will find one which measures 11 in. x 17 in., taken with the 200 in. Hale telescope.

An article which deals with this photograph gives the following information: Hubble classified it as an Sc type spiral; a super-nova was discovered in M101 in the year 1909 by Max Wolf; in 1917 three ordinary novae were seen and M101 is resolved into stars by the 200 in. telescope.

For information as to how the spiral structure of the Milky Way is being ascertained with the aid of radio telescopes, Mr. Twining should read "Radio Studies of Interstellar Hydrogen," by Bart. J. Bok, page 408, October, 1954, issue of the *Sky and Telescope*.

I also recommend "Edwin Hubble, Observational Cosmologist," by N. U. Mayall, page 78, January, 1954, issue of *Sky and Telescope*.

I would also like to point out that with present equipment it is not possible to detect planetary systems around any of the nearest stars, at distances of four or so light-years, yet alone detect them in galaxies at least 10^6 light-years away. Please note I am not saying they do not exist, I believe they do, but we just cannot detect them.

Mr. Hamilton may like to know that the distance of M31 (Andromeda Nebula) is now considered to be 1,500,000 light-years, and all other Extragalactic Nebulae distances at least doubled, this fact was recognised by astronomers in 1952, some of the important information being obtained with the Hale 200 in. telescope, see "The Distance Scale of the Universe," parts 1 and 2, *Sky and Telescope*, June and July, 1953, issues.—B. H. BEESTON (Enfield).

Xylophone Keys

SIR,—I have always been interested in musical instruments, especially one-stringed fiddles and xylophones. A short time ago I made a small xylophone, using the note scheme given in the present article, that is, making C2 half the length of C1, and so on. This I got from the usual formula for organ pipes, and have since proved it to be wrong for bars or tubes that are struck as opposed to being blown.

Having made C2 half the length of C1, I found that when struck it gave a note two octaves above C1. I next tried the formula given for the tubes in the PRACTICAL MECHANICS "Westminster Chimes," which was C2 being .707 of C1, and used all the other constants given in the article for the other notes. I was pleased to find that this gave the correct results.

A point not mentioned in your present article is that if it is desired to flatten the pitch of a note slightly, this can be done by scooping out the centre of the underside of the bar. Also, better results are obtained if the bars are supported at a quarter of their length from the ends.—NORMAN C. BANFIELD (YEOVIL).

Flying Saucers

SIR,—I have read, if I suppose, everything that has been written about the objects collectively named Flying Saucers. That there have been strange objects seen in the sky for very nearly 100 years has never been doubted.

All the writers whose books I have so far read suffer from the same unfortunate

disability, that they attempt to prove something; either that the whole idea is an illusion or that we are visited by inhabitants of other planets.

The only fact that appears indisputable to me is, that a large number of Saucer Sightings are quite inexplicable by any causes so far within the scope of our present knowledge. I cannot help noticing that those who attempt to "explain" the whole business away as an illusion do not trouble to make themselves acquainted with all the facts at their disposal, and the simple explanations of scientists and astronomers are quite untenable, and demand far more credulity than I am prepared to possess.

Adamski's book, which, by the way, is a very valuable contribution to the literature of the subject, is obviously written in all sincerity, but there is one point upon which I feel he falls. It is suggested that the "Visitor" communicated by a sort of mind-reading process. Popular science fiction has so often used this theme that it is high time that the essential absurdity of the idea is exposed.

We have on this earth a highly civilised race of beings in addition to the race we call Man. I refer to the ants. Now it seems to me that someone should surely have been able to discuss their problems with the ants on a thought transference plane. No one has done so yet, and I fail to see that we have any right to suppose we can communicate with any other races alien to Man.

It is fairly certain that, with what little knowledge we have at the moment, the inhabitants of other worlds are entirely alien to Man.—K. E. NICHOLLS (S.E.3).

Atomic Explosions and the Weather

SIR,—I was very interested to read H. H. Porritt's letter in the September issue of PRACTICAL MECHANICS on the effect of atom explosions on the weather.

While I agree that his scale model of the earth and an exploding atom bomb is correct, and that the explosion and heat alone would not affect the weather, I feel that what really needs looking into are those radio-active particles he mentions.

I have thought for some time that A bombs might affect the weather, and his letter induced me to delve into some science books. I discovered some startling facts, which I think other readers might be interested in.

To begin with, sunspots affect our weather. They cause cyclones, and the latitude of the storm belt on earth changes as the latitude of sunspots changes on the sun. One book gives an interesting chart showing that an increase in sunspot activity means increased magnetic activity, increased aurora effects, and an increase in the height of the water level in Lake Victoria Nyanza—in other words, more rain, so that the waxing and waning of sunspot activity corresponds with a change from cold and wet to hot and dry summers respectively.

Now, sunspots affect the weather thus

(Continued on page 129)

HIGHSTONE UTILITIES

Soldering Irons. Our new streamlined iron is fitted with a Pencil Bit. 200/250 v. 50 watts, 11/8, post 6d. Standard iron with adjustable bit, 200/250 v., 60 watts, 13/6, post 6d. Heavy Duty Iron, 150 watts, 16/6, post 8d. All parts replaceable and fully guaranteed. Small Soldering Irons, for use on gas, 1/4, post 6d. Resin-cored solder for easy soldering 6d. packets or large reels 5/-, post 9d.

Bell Transformers. These guaranteed transformers work from any A.C. Mains, giving 3, 5, or 8 volts output at 1 amp., operate bulb, buzzer or bell. Will supply light in bedroom or ladder, etc. PRICE 9/-, post 8d. Similar Transformer but with output of 4, 8 or 12 volts, 12/6, post 10d. Transformer with similar output, but with fused secondary and earth terminal, 18/-, post 1/- BELLS for use with either the above or batteries, 6/8, post 6d. "Big Ben" Chimes. Housed in Cream Plastic Case. Easily connected to give Two-Note Chime from Front Door, and Single Note from Rear. Operated from 6-9 volt Batteries or Transformer (shown above), 21/2, post 1/-.

EX-R.A.F. 2-valve (2-volt) Microphone Amplifiers as used in plane inter-com., in self-contained metal case; can be used to make up a deaf-aid outfit, intercommunication system, or with crystal set; complete with valves and fitting instructions, 20/-, post 2/-. Useful wooden box with partitions to hold amplifier, 2/- extra. Ditto, less valves, 10/-.

Sparking Plug Neon Testers, with vest-pocket clip, 3/3, and with gauge, 3/8, post 3d. S.H.C. Neon Indicator Lamps, for use on mains showing "live" side of switches, etc., 3/6, post 4d. Neon Indicator, complete with condenser (pencil type), with vest-pocket clip, indispensable for electricians, etc., 7/6, post 5d.

Crystal Sets. Our latest Model is a real radio receiver, which is fitted with a permanent crystal detector. Why not have a set in your own room? 12/6, post 8d. Spare Permanent Detectors, 2/- each. When ordered separately, 2/6. With clips and screws, 2/10, post 3d. Headphones, brand new, S. G. Brown, G.E.C., etc., 23/-, and super-sensitive, 30/- a pair, post 1/-.

Headphones in Good Order, 6/-. Better quality, 7/6 and 10/-. Balanced armature type (Very sensitive), 13/6. All post 1/-. **New Single Earpieces**, 3/6. Balanced armature type, 4/6 (two of these will make an intercom set). Ex R.A.F. earpiece, 2/6, all post 4d. **Headphones with moving coil mike**, 15/-. Similar phones with throat mikes, 12/6, post 1/-. **Headphone Cords**, 1/3 a pair, post 3d. **Replacement Bands**, 1/3, post 4d. **Wire Bands**, 6d. (All Headphones listed are suitable for use with our Crystal Sets.)

Hand Microphones, with switch in handle and lead, 5/6. Tannoy, 7/-. Similar instrument, moving coil, 8/6. All post 1/-. **Mik type with switch**, 3/6, post 4d. **Mike Buttons (carbon)**, 2/- **Moving Coil**, 4/6; **Transformers**, 5/- All post 4d, each.

Rotary Transformers, 24 v. Input : Output 120 v., 2 amp. in case with suppressors, etc., easily converted to run as a high-voltage motor, 25/-, carr. 5/-. Also 12 v. Input : Output 6 v., 5 amp.; 150 v., 10 mA.; and 300 v., 20/240 mA., 22/6, carriage 5/-.

Morse Keys.—Standard size keys wired to work Buzzer or Lamp, 3/-, post 6d. Slightly smaller keys, 2/6, post 4d. BUZZERS, 3/9, or heavy duty, 4/6, post 5d.

Terminals, brass, 2BA, mounted on strip 6d. pair. .0005 Airspaced Variable Condensers, 2/6, post 4d. .0003 twin gang with trimmers, 2/6, post 4d. 24 volt, 15 m.m., M.E.S. Bushes for model railways, etc., 1/- each, 10/- doz., post 4d. **Wander Plugs**, Brass, 1/6 doz., post 4d. **Fuses**—1 amp., 1 1/2 in., packet of 10, 2/6, post 3d. Also 150 mA. and 250 mA., same price. **Hydrometers**, Standard Type, 6/-, post 6d. Ex-G.P.O. Telephone Twin Bells, with box, 5/-, post 1/- Single Telephone Bell, 3/6, post 6d.

Bargain Parcels, of really useful equipment, containing Switches, Meters, Condensers, Resistances, Phones, etc., 10/- or double assortment, 17/8; treble 25/-, All carriage 2/-. This country only.

Meters, 20 amp, 2 1/2 in. m.l. 12/6. 15 v., 2 1/2 in. m.c., 150 v., 2 1/2 in. m.c., 10/-; 3.5 amp., 2 1/2 in. T.C., 6/-; 4 amp., 2 1/2 in. T.C., in case with switch, 9/6; 100 mA. 2 1/2 in. m.c., 7/6; Meter Units containing 2-500 microamp. movements, 7/-, post 1/-.

Money refunded if not completely satisfied.

HIGHSTONE UTILITIES
58, New Wanstead, London, E.11
Letters only.
New Illustrated List sent on request with 11d. stamp and S.A.E.



said a silversmith, "Pleasant to handle, very sensitive controls."

He was one of the many users of our Flamemaster Mark II and the three comments he made probably sum up the main reasons for the Flamemaster's immense popularity.

- Also:
- It burns coal-gas or bottled-gases of the butane type with equal efficiency . . .
 - The air or oxygen pressure needed is comparatively low . . .
 - All the different flame-units are easily interchangeable . . .
 - It won't splutter or give you an unstable flame . . .
 - It won't leak, even on high pressures . . .
 - It won't raise your running-costs (our economiser-trigger sees to that) . . .
 - But it *will* bring speedy and reliably controlled heating right to the spot where you need it . . .

remember the name

FLAMEMASTER MARK II

Write for full details to :-

STONE-CHANCE LIMITED, DEPT. F27, LIGHTHOUSE WORKS, SMETHWICK 40, BIRMINGHAM. TELEPHONE: BROADWELL 2651.
LONDON OFFICE: 28, ST. JAMES'S SQUARE, S.W.1. TEL.: WHITEHALL 6002.

SPECIAL OFFERS

TERRY ANGLEPOISE LAMPS.—Complete with flex and S.B.C. holder, shade, etc. Will stay put in any position, wall or machine fixing. 35/-, post 2/6.

TELEPHONE HAND SETS.—Brand new with cord, 15/- each; post 1/6.

WALL TELEPHONES.—"Call and reply." Perfectly made, robust and efficient, suitable for home or office. £5 per pair.

TELEPHONE EARPIECES.—Sound powered, suitable as receiver or microphone. These self-energised units will provide perfect 2-way communication without the use of batteries. 6/- each. Post 6d.

LOW VOLTAGE CIRCUIT TESTER.—A self-contained unit for making a complete and rapid check of the generator-battery circuit of a vehicle. Battery voltage, regulator and cut-out settings and generator performance can all be easily determined. American made. Complete with instruction book. £5/10/-, post 2/-.

BALL RACES.—No. EE2, 1/2 in. x 1/2 in., 3/-, 30/- doz., post free.

TIRUST RACES.—13/16 in. x 1/2 in., 1/6, 15/- doz., post free.

SWITCHES.—A row of 5 in a flush mounting bakelite moulding 5 1/2 in. x 1 1/2 in. x 2 1/2 in. Ideal for model railways, etc., 5/6, post 8d.

P.M. SPEAKERS.—In cases, ideal for extension speakers, 6 1/2 in., 30/-; 5 in., 17/6, postage 2/-.

THERMOSTAT.—For frost protection, on at 34 deg. F., off at 49 deg. F., 11 amps. at 250 volts adjustable, 4/8, post 6d.

THERMOSTAT SWITCH.—Bimetal type in sealed glass tube, 2 1/2 in. x 1 1/2 in., 30 deg. Cent. Ideal for Aquariums, Wax and Oil Baths, Gluepots, etc. Will control 1 amp. at 240 v., 5/- each, post 6d.

THERMOSTAT.—Satchel 12 in. stem., 0/250 v. A.C./D.C. 15 amps. A.C., 1 amp. D.C. 10 to 90 deg. Cent., 35/-, post 1/8.

24-VOLT D.C. MOTORS with double ended shaft 2 in. x 3/8 in., 8/6, postage 1/-.

KLAXON GEARED MOTORS No. K5S3-W7. Torque lbs./in. 15. R.p.m. 175. Motor r.p.m. 1,400 at 230 v. A.C. Split phase induction type, £10 each.

GEARED MAINS MOTORS.—Universal Series Type for 230 volt A.C./D.C. 100 r.p.m. torque 7 lbs./ins. Klaxon No. EK3UB1-W3 complete with control box to enable speed to be varied, 115/-, complete.



ELECTRO MAGNETIC COUNTERS.—Post Office type 11A, counting up to 9,999, 2 to 6 volts D.C., 3 ohm coil, 12/6 each, post 1/-. Many other types in stock. Lists sent with order or send S.A.E.

MECHANICAL COUNTERS to 99,999 only 7/6 each, Post 6d.

ROTARY CONVERTERS.—From 24 volt D.C. to 230 volt A.C. 100 watts, 92/6 each; also available with 12 volt input, cpe., 7/6.

AUTO CABLE for car wiring and all electrical purposes, waterproof. Single, 4/- doz. yds., 20/- 100 yds. Twin 3 core or single heavy, 5/- doz. yds., 37/6 100 yds., 5 core, 6/- doz. yds., 45/- 100 yds.

VACUUM PUMPS or Rotary Blowers.—Ex R.A.F. Brand new, 7 cu. ft. per min. 10 lbs. per sq. inch at 1,200 r.p.m. Ideal for a brazing torch, etc. Size 6 in. x 4 in. x 4 1/2 in. 2 x 1/2 in. shaft, 22/8 each, post 2/-.

MASTER CONTACTOR.—A precision made clock movement, contact making and breaking twice per second, with regulator. Brand new in soundproof oak case. Many uses, blinking lights, etc. Only 12/6, post 2/-.

PORTABLE ELECTRIC BLOWER.—This unit is a powerful 220 watts electric motor, operating on 220/230 volts. Enclosed type with handle. 6 1/2 in. of metallic flexible hose and nozzle is included, also 7 yds. C.T.S. flex for connection to the mains, 130/- complete. Carriage 7/6.

INSPECTION LAMP.—Complete with Battery Case. Fits on forehead. Leaves both hands free, 7/6, post 1/-. Takes a standard Ever Ready battery. No. 1215, 2/9, post 6d.

MICROAMMETERS, 250 F.S.D. 3 1/2 in. FLUSH. MODEL S37. Specially scaled for cost meters. Knife edge pointers, magnetic shield, Guaranteed. Brand new. Not Govt. surplus. Offered about half usual price. 55/-, post free.

VOLTMETERS.—0-300 volt A.C. 50 cycles. 2 1/2 in. flush moving coil, rectifier type, 30/-, post 1/2/-.

VOLTMETERS for A.C. Mains 50 cy. reading 0 to 300 volt with clear 5 in. dial only 60/-; worth double.

VOLTMETERS.—0-300 Flush D.C. moving Coil, 10/6; 0-20, 2 1/2 in. Flush Moving Coil, 7/6; 0-40 2 1/2 in. Flush M.C., 10/6, post 1/-.

AMMETER.—2 1/2 in. Flush 0-25 amps. Moving Iron. D.C. 7/6, post 1/2/-.

MOVING COIL METER with 1 M/A movement, 2 1/2 in. flush, rectifier type, scaled 0/100 volts A.C. Resistance 100k, ohms. A very useful basic meter, 30/-, post free.

LISTS AVAILABLE.—Motors, Meters, Telephone, Rectifiers, Relays, Potentiometers, Resistances. Send S.A.E.

WILCO ELECTRONICS
DEPT. P.M.,
204, LOWER ADDISCOMBE ROAD,
CROYDON.



**THE SUPER MODERN
"FLIGHT LIEUTENANT"
HANDLESS WATCH
NO GLASS • NO DIAL
• NO HANDS •**

Sent
for 5/-
DEPOSIT

Built for strength, fitted with Aircraft shock resisting movement. Lever escapement. Anti-magnetic and recoil click spring to prevent overwinding. Handsome chrome case. Expanding bracelet 10/6 extra if required. Time shown by revolving figures. Sent for 5/- deposit. Balance 10/- monthly. Non-luminous Night Dial 6/6 extra. Manufacturer's full guarantee. Cash price 79/6. Post etc., 1/3. Send now.

**LIEBERMAN
and GORTZ
21x47**

Sent for 17/6
WONDERFUL 21
MAGNIFICATION!



Brighter, more powerful and wider angle than any other Continental Prismatic Binoculars. Fantastic, and a revelation to all. ONLY Lieberman & Gortz 21 x 47 (O.G. internal diameter) lenses will give you such 3-D viewing. Day and night BLOOMED LENSES. 9 1/2 in. x 6 1/2 in. 28 ozs. Complete in case with leather slings. 17/6 deposit. 39/6 monthly. Cash 19 Gns. Worth much more. OTHER MODELS: 8 x 25, £10.17.6; 8 x 30, £11.17.6; 8 x 32, £13.19.6; 8 x 40, £15.19.6; 10 x 40, £17.19.6; 12 x 40, £18.19.6; 15 x 40, £19.19.0; 20 x 40, £19.19.0; 16 x 50, £48. OR ALL ON TERMS.

Send for FREE illustrated catalogue of other Binoculars, Tents, Marquees, Camping Equipment, Tarpaulins, Watches, etc. TERMS. State Catalogue required.

HEADQUARTER & GENERAL SUPPLIES LTD. (Dept. PMC/3), 196/200, COLDHARBOUR LANE, LOUGHBORO' JUNCT. LONDON, S.E.5. Open all Saturday. 1 p.m. Wednesday. Personal Callers Welcomed.



COMPLETE SET OF
**CAR SEAT
COVERS**
ALL SIZES

ONLY 49/11
THE SET, POST 1/7
(8 to 10 H.P.)
Renew your Car Upholstery in a 5-minute fitting. Real tailored seat covers. Red, Green, Blue and Brown of really super hard wearing smart material. Transforms interior of your car like new. 12 to 14 h.p., 69/6; Over 14 h.p., 79/6. Cars with arm rests 12/6 extra. State make, year and h.p., or 2 or 4 door. Post and Pack. 1/7. Only a tremendous turn-over enables us to offer at such a reasonable price. So send now and don't miss this wonderful bargain.

CHEMISTRY

EQUIP YOUR HOME LABORATORY FOR EXPERIMENTAL WORK

Send 2½d. Stamp for copy of Complete Price List of Wide Range of Apparatus and Reagents.

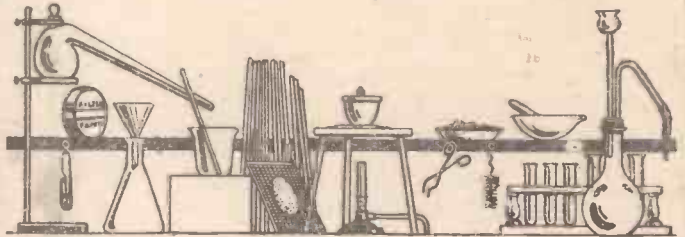

Beakers, Bunsen Burners, Crucibles, Flasks, Funnels, Gas-Jars, Glass Tubing, Spirit Lamps, Test-Tubes, Thermometers, Tripods, and many other pieces of APPARATUS also choice of 120 different CHEMICALS

BOOKLETS

"EXPERIMENTS IN CHEMISTRY," 10½d. "FORMULAE & TABLES," 10½d. "EASY HOME CHEMISTRY FOR BOYS," 2/3. (including Postage)

ORDER BY POST OR PAY US A VISIT

A. N. BECK & SONS, 60, STOKES NEWINGTON HIGH STREET, LONDON, N.16 (Dept. A). Phone: Clissold 0335.

SPECIAL OFFER G.E.C. & B.T.H. GERMANIUM CRYSTAL DIODES

1/- each. Postage 2½d.

Diagrams and three Crystal Set Circuits Free.

A large purchase of these fully GUARANTEED diodes from the manufacturers enables us to make this attractive offer.

COPPER INSTRUMENT WIRE ENAMELLED, TINNED, LITZ, COTTON AND SILK COVERED.

All gauges available.

B.A. SCREWS, NUTS, WASHERS, soldering tags, eyelets and rivets. **EBONITE AND BAKELITE PANELS,** TUFNOL ROD, PAXOLIN TYPE COIL FORMERS AND TUBES. ALL DIAMETERS.

Latest Radio Publications. SEND STAMP FOR LISTS

CRYSTAL SET

INCORPORATING THE SILICON

CRYSTAL VALVE

Adjustable Iron Cored Coil.

RECEPTION GUARANTEED

Polished wood cabinet, 15/-, post 1/-. A REAL CRYSTAL SET NOT A TOY

POST RADIO SUPPLIES

33 Bourne Gardens, London, E.4

16 SWITCH BOX UNIT. Containing 16 on/off toggle switches, slide and enclosed terminal block, size 7-in. x 4-in. x 2-in. Price 10/6, plus postage 1/6. Suitable for control of model railways, etc.

ROTARY CONVERTER. 230 d.c., 12 V, 3-amp. d.c. complete in case with switch and lead. Radio suppressed. Price 25/-. P. & P. 2/6.

ARTHUR T. SALLIS (P.M.), 93, North Road, Brighton, Sussex. Tel.: Brighton 25806

The IDEAL CHRISTMAS GIFT

for all HANDYMEN



**Cub
Drill**
£5.19.6

Wolf Cub

HOME CONSTRUCTOR EQUIPMENT

comprising accessories for DRILLING, SAWING, SANDING, GRINDING, POLISHING, BUFFING and WOOD-TURNING. Complete £16.17.6

Individual Kits from £7.0.5

Sold by all good tool dealers. Write for folder "Profitable Pleasure"

WOLF ELECTRIC TOOLS LTD · PIONEER WORKS · HANGER LANE · LONDON · W.5
Tel: PERVALE 583114 · Branches: BIRMINGHAM · MANCHESTER · LEEDS · BRISTOL · NEWCASTLE · GLASGOW

MAKE MONEY — making casts

with VINAMOLD

A grand spare-time occupation

WITHOUT any previous experience you can mass-produce any object, from a chessman to a candlestick, statuette or model ship, in plaster, resin, concrete, etc. with "VINAMOLD" the flexible mould that gives the BEST results. Easy to work, can be used over and over again. Needs NO special equipment, provides a profitable and enjoyable spare-time occupation with minimum outlay.

Write for full details and instructions. Also available: Illustrated booklet describing "VINAMOLD," methods of heating and melting, preparation of models and moulds, etc. Price 1/6 post free, from:—

VINATEX LTD. (Dept. P.M.3), CARSHALTON, SURREY



Micromodels

MODELS IN CARD

MAKING these tiny three-dimensional volumetric models is a fascinating lifetime hobby: neat and tidy, too. Your workshop goes into a cigar box. Authentic detailed subjects shrunk to small dimensions. Each gives up to 100 hours of fascinating re-creation. Printed in colour on special cards and costing only pence models often sell for guineas.

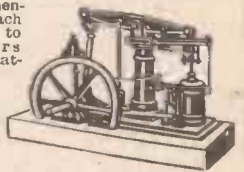

OVER A 100 SUBJECTS

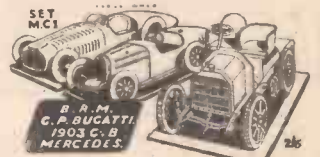

HISTORIC, ARCHITECTURAL, MECHANICAL, RAILWAY, MARITIME, AERO, ETC.



SEND stamped addressed envelope for Illustrated List of over 100 models.

MICROMODELS LTD., 3 (U), Racquet Court, London, E.C.4.

because of the particles they spray out—electrons, ions, ultra-violet, alpha, beta, gamma, cosmic rays, etc., but most ultra-violet rays and the rest cannot penetrate our atmosphere far, but ions apparently do, and moisture condenses on ions, forming clouds and rain.

Now uranium gives off rays that ionise air, just as sunspots do, and certainly an atomic explosion fills the air with radio-active particles and all sorts of rays from ultra-violet to cosmic that ionise the air, condensing moisture and producing rain. The conditions prevailing in the sun and an atomic explosion must be similar, as the temperatures reached are similar and in both cases radio-active particles are thrown out.

Another point is that those ultra-violet rays and the higher forms of energy released

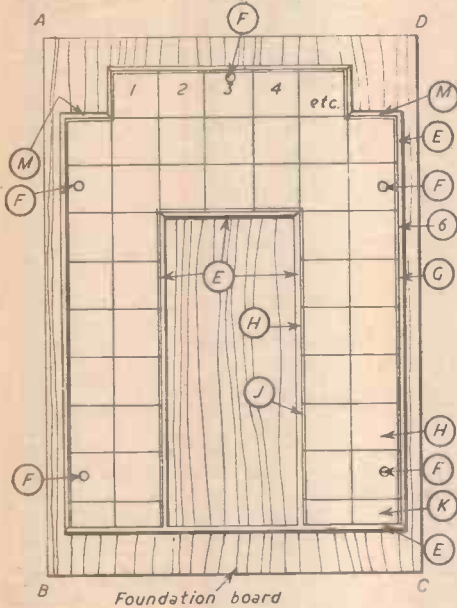

Fig. 2.—Laying out the tiles on the baseboard.

convert oxygen to ozone—in the upper air in the case of the sun, in the lower levels in the case of the A or H bomb. This brings me to what seems like direct evidence that what I have written might be true.

I have, mounted on a post, a quartz tube containing methylene blue, which during daylight is more or less bleached by ultra-violet rays, thus roughly measuring their intensity. By means of a scale of tints one supplies a number to the degree of bleaching.

From March to May, when I had this instrument in action, the ultra-violet intensity generally never rose above 2, but now and again it very suddenly rose to 8 or 9, accompanied at the same time by a wave of cold air lasting from one to three days. In view of the increased U.V. radiations I would expect to find the quantity of ozone in the air also in excess of normal, and possibly magnetic disturbances too, but I have no means of measuring these. Possibly the almost unbearable "freshness" of the air at these times was caused by excess of ozone.

In the early days of atomic bomb tests, when each new explosion was announced, I noticed that each explosion seemed to be followed by a cold spell in from five to ten days. The Russian explosion this September was also followed by a marked cold patch.

In view of this and the rest of the evidence it seems not unreasonable to say that atomic explosions do affect the weather a lot—in fact, as we have exploded bigger and better bombs in the spring so our summers have become steadily worse.

Finally, I have looked at the sun through a 3in. telescope on two or three occasions this year, and each time his "face" seemed remarkably free from spots—which suggests

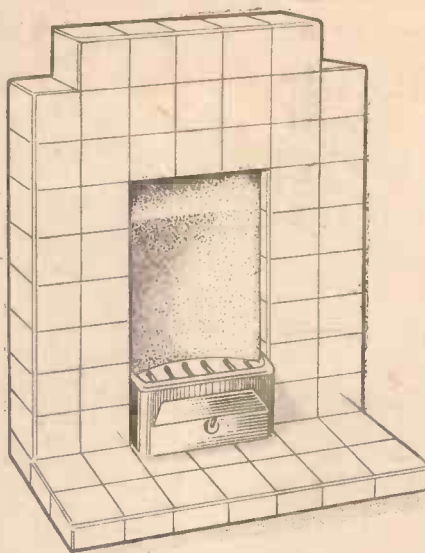

Fig. 1.—How the completed fireplace should look.

that if it had not been for man's atomic explosions we would have had a hot, dry summer.—M. M. DAVIES (Margate).

A Tiled Fireplace

SIR,—With reference to the request from Mr. E. Ratcliffe regarding materials and construction of a tiled fireplace (Information Sought, October issue) the following particulars may help him.

Having chosen a bedroom grate as pattern, illustrated in Fig. 1, proceed as follows:—

Secure a large flat board to make foundation base A, B, C, D, and upon this design the grate. In all measurements carefully allow a comfortable fit for tiles.

In Fig. 2, E represents battens 2in. x 1/2in. cut and screwed into position.

The tiles chosen may have a mottled effect; these are 4in. square, H for the main body and patterns G and M (Fig. 3) for sides and top, with J for the inner portion. This tile could be 4in. x 2in. as shown. The lower tiles K being 4in. x 2in.

The local builders' merchants would probably supply suitable tiles, also a special hardening cement for their fixing.

From the ironmonger purchase iron rods N (Fig. 3) 1/2in. diameter bent to shape and used either straight or wavy. These are for reinforcing. Further, obtain, say, five or six pieces of 20 gauge 1in. wide hoop iron, bent to shape F (Fig. 3). These are to be inserted at points F in Fig. 2 and used to fix grate to wall.

Having procured all items required, commence by setting tiles in "frame" or "jig," faces down, and also against the battens.

Number each one to make final assembly easy. Place these in order in a large bath of water; the damping will assist the cement to adhere when placed in frame.

Mix the prepared cement to a smooth consistency and smooth all over tiles in the frame. Into this body of cement lay the reinforcing rods N and the small fixing brackets F. Finally, body-up with further cement, smoothing surface and making sure that all joints have had a small fillet of cement between them. When all is set hard gently remove from frame, clean down, and then, having fitted back tile, line grate and front, the grate is ready. Should a small hearth be required, then the same procedure could be followed. This grate has been designed for a 12in. fire and no difficulty should arise in fitting either grating or fret.—R. B. G. (Ilfracombe).

Coal Flowers

SIR,—In the October issue of PRACTICAL MECHANICS, in Information Sought, Mr. L. A. Fantozzi asks for an effective recipe for a depression garden or coal flowers. I think I may be able to help him, as I have a recipe, dating from pre-war days, for what is called a "Coalie Flower":—

- 1 zd. bottle of red ink (now 4d.).
- 3 tablespoonsful of household ammonia (clear).
- 2 tablespoonsful of salt.
- 3 packets of Hayes Powder Blue.
- 3 tablespoonsful of water.

Take several medium-sized pieces of coal and put them in a bulb bowl. Pour the

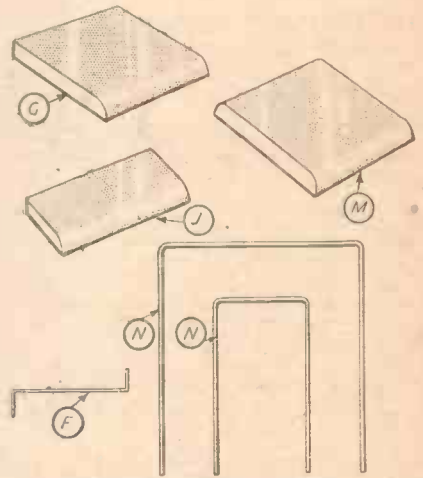

Fig. 3.—The various tiles used and the reinforcing rods.

mixture over the coal and place in a warm, dry spot. Every day add 1 tablespoonful of water, 1 teaspoonful of salt.

The final result is like a multicoloured cauliflower. I have often done it and it is always successful.—M. M. DAVIES (Margate).

SIR,—Regarding the query from Mr. L. A. Fantozzi on the subject of coal flowers the following is a copy of a cutting taken from the *Evening Post* some time ago; this might be what is wanted.

Put a fair-sized lump of coal in an ornamental basin or dish. The coal's grain must be upright. Mix two tablespoonsful of geissen blue, one tablespoonful of red ink and two tablespoonsful of common salt; each day pour one tablespoonful of this mixture and one of water over the coal.

Then you watch a beautiful coloured plant creep over the coal. Chemists sell geissen blue.—H. L. GRIMSHAW (Doncaster).

Table Tennis Table Construction

SIR,—With reference to the request for constructional details of a table tennis table (Information Sought, August issue), I would point out that the suggested construction as given by a Mr. Garnish in your October issue is far from adequate.

First, the size of each half of the table was given as 4ft. by 4ft. This is incorrect as the official size of a T.T. table is 5ft. wide by 9ft. long. Each half should therefore be 5ft. by 4ft. 6in.

Secondly, the wooden framework and legs as suggested are much too frail and should all be of 1 1/2in. square or 2in. square timber.

Thirdly, the surface of the table is proposed to be made of hardboard. If serious table tennis is proposed it will be absolutely necessary to have plywood at least 1/2in. in thickness. If possible 3/4in. thick plywood is preferable and the plywood should be as free as possible from air holes or defects so that

a uniform response be obtained from the entire surface.

It is also necessary that each half of the table has one or preferably two battens underneath the surface of the table as the area is too large to be supported only at the edges by the framework. Without these battens the centre will react soggily and also warping will occur.

Lastly, it is much better to provide each half of the table with four legs, and to leave each half separate from the other. A properly constructed table is quite weighty and it is much easier to handle in separate halves. If you must construct it hinged at the centre, then do so so that the surface folds *inside* and is thus protected when stacked away.—E. W. PHILLIPS (London, N.2).

Conversion to Oil Firing

SIR,—Regarding the oil firing query of Mr. T. S. Gooch (Farnham), *PRACTICAL MECHANICS*, September, 1954. We note his consternation at the running costs of a pair of Potterton Rex D.6 gas-fired domestic boilers, and assure him that a very efficient oil burner conversion can be carried out on these boilers. The saving effected on two similar boilers in this area was 40 per cent. off the previous quarter's gas accounts for the same amount of washes at the machines.

We do not advise heat exchange units being installed; the saving is so little, as the mean temperature of the H. and C. mixed water from the Bendix wastes is so low that little exchange takes place. In any case prevention of expense is better than a cure!—ROSS BROTHERS (Heating and Sanitary Engineers).

The Walton Mole

SIR,—In reply to the query in Information Sought (September issue) regarding the Walton Mole, the device consists of a brush which is propelled along a tube by water pressure. Its design is such that it will negotiate bends and will pass a'ong "T" pieces and will operate in any pipe irrespective of length, orientation or construction, subject to the one qualification that at no time must the bore be restricted more than $\frac{1}{8}$ in. below nominal sizes.

The device is at present marketed in sizes from $\frac{1}{8}$ in., $\frac{3}{16}$ in., then rising by small increments to 2 $\frac{1}{2}$ in.

The device is designed to remove semi-solid residues. Its chief use at the moment is in removal of residues from pipes carrying beers and other alcoholic liquids, though there is no reason why it should not be used to remove sludge or similar deposits from any pipe line provided the liquid is not a rubber solvent.—THE WALTON MOLE COMPANY (Middlesbrough).

Ancient Egyptian Tools

SIR,—Readers interested in the above subject which was mentioned in the Editorial of the August issue, should consult "I Monumenti dell'Egitto e della Nubia"; illustrated by Professor Ippolito Rosellini, in the library of the British Museum. Other works on tools generally are: "The Arts of Mankind," by Van Loon. "Tools and Contrivances Used in Handicraft," by the Rev. Arthur Riggs, M.A. Vols. 21 and 22, of "English Mechanics" (1875), being the Cantor Lectures on the material, form, and principles of tools, etc., delivered before the Society of Arts. "Theatrum Instrumentorum et Machinarum," Besson, 1582. "Les Raisons des Forces Mouvantés," De Caus, 1624. Moxon's "Mechanic Exercises," 1677-1683. "Theatrum Machinarum," etc., revised, Leupold, 1724-1727. "Panoplia Omnium," Hartman Schopper, 1548. Nearer our own times Holtzapfel, Evans, Lukin, Northcott, etc., books on turning, and quite a number of craft anthologies. Some of Moxon's illustrations are reprinted in "A Short

History of the Building Crafts," by Briggs.—J. E. D. (Tyne Dock).

An Electric Gas Lighter

SIR,—I have read one or two articles in *PRACTICAL MECHANICS* describing electric gas lighters, and thought you might be interested in one I have been using these past two years.

It consists of a fountain pen type battery torch which costs about 2s. without batteries. This consists of an outer case in two parts with a bayonet-type fitting; the top part carries a bulb which is replaced by a gas-

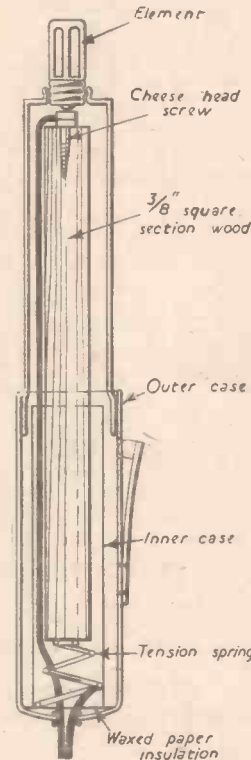

The gas lighter details.

lighter element obtained from a well-known multiple store for 1s.

The bottom half has an inner lining of brass insulated from the outer and making contact, when the switch is depressed, with the outer case, see sketch.

A hole is drilled in the bottom of the case through which is taken the twin flex. One end of the flex is attached to the tension spring in the bottom of the case (taking care to replace the waxed paper insulation), the other is taken to the piece of wood as shown in sketch, and takes the place of the battery which the torch normally contains. I have it connected in the usual way to the 5-volt tapping of a transformer, the voltage drop in the wire giving me a nice red glow on the 1 $\frac{1}{2}$ -volt element.

A small curtain ring is taped on to the flex near the torch, which is hung on a cup-hook near the stove, but no doubt further refinements are possible.

The present lighter has been in use for over two years at the cost of a replacement element.—G. KEENAM (Hamilton).

A 3-D Fallacy ?

SIR,—In connection with the use of 3-D spectacles by the public when viewing 3-D films or 3-D television you might think it worth while drawing to their attention in one of your journals the fallacy that a system which requires no glasses would be preferable to one which requires them. A considerable number of critics and correspondents, including the Marquis of Donegall, in the November issue of *PRACTICAL TELEVISION*, hold such a view, and on that account their readers, the public, hold the same view.

Experts who have seen 3-D films without glasses in Moscow reported that the polarised light method of projection and viewing is far superior. There is no method by which a 3-D effect can be obtained without glasses from every position in the cinema, which forces every patron to sit rigidly still, as a deviation from that position by as little as two inches to either side destroys the effect and causes severe eyestrain. The comment of these experts after the show was, "We thoroughly enjoyed ourselves, with a splitting headache at the end." This disposes of the fallacy that

eyestrain is attributable to the polarising spectacles. The only time eyestrain is from that cause is when the spectacles are defective in quality. Any system which dispenses with the use of spectacles would have the same causes of eyestrain as a system which requires glasses. In fact, a system for which no glasses are required would have two serious additional causes of eyestrain. One the lack of crisp definition due to the splitting of the screen into narrow bands, and the other due to the necessity of keeping the eyes rigidly in one position in space.

It is true that the spectacles absorb some light, but the lack of light is due to the lack of additional illumination in the projectors to compensate for that absorption.

One more disadvantage of 3-D without glasses; that is the fact that one cannot see the picture in 2-D if one so wishes except by closing one eye. Thus conservative tastes would not be catered for. The same people who object to the use of polarising spectacles go to the expense of going on holiday to the South of France, where they may wear polarising sunglasses every day and all day. From the popularity of various makes of sunglasses, good and bad, it is obvious that the public do not object to wearing spectacles, provided they are their own. When at a later date the Polaroid Vectograph method of projection is available, no doubt a considerable number of low-priced, good quality polarising glasses will be on sale, and the public will not object to wearing those any more than they object to wearing sunglasses.

So obviously it is nonsense to say that 3-D without glasses would be better, and it would be interesting to know what reasons those people who believe it would give. So far as I am aware not one of these critics has endeavoured to explain the superiority of such a system.

It would be interesting to know also whether people who are already spectacle wearers would object to wearing polarising filters as clip overs. I think they would object only in so far as the Press tell them they are objectionable.

Graining Woodwork

SIR,—Regarding the reply to E. J. Ormerod in the November, 1954, issue the material should not be light-coloured varnish, but a light, flat undercoating and darker coloured scumble for figure.

Rub down woodwork. Give flat ground paint first, let dry, and the dark scumble follows and figuring is done with brush or comb. Finally, varnish with indoor varnish.—E. J. HIGGINS (Essex).

Fluorescence Under Ultra-violet Light

SIR,—Re the letter from F. G. Morgan (Manchester) concerning the above, Mr. Morgan would find a great deal of interest in "Fluorescence Analysis in Ultra-violet Light," by Radley and Grant. This book is available at the Manchester Central Lending Library, St. Peter's Square, Manchester.—C. R. O'CONNOR (Manchester).

Reinecke's Salt

SIR,—In answer to Mr. L. A. Fantozzi's inquiry (October *PRACTICAL MECHANICS*) "Ammonium reineckate" appears to be an incorrect name for the compound known as Reinecke's Salt. Its chemical name is ammonium tetrathiocyanotodiammine chromite and its formula is

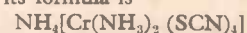

It crystallises in rose-coloured plates and may be prepared by adding ammonium dichromate to fused ammonium thiocyanate (sulphocyanamide) and extracting the cold mass with cold water, when the chromite will dissolve. The solution should be evaporated by warming, but the temperature kept below 50 deg C., since above this temperature the compound decomposes.—R. I. BELLAMY (Dorset).

READERS' SALES AND WANTS

The pre-paid charge for small advertisements is 6d. per word, with box number 1/6 extra (minimum order 6/-). Advertisements, together with remittance, should be sent to the Advertisement Director, PRACTICAL MECHANICS, Tower House, Southampton Street, London, W.C.2, for insertion in the next available issue.

FOR SALE

STARLON PLASTIC ENAMEL PAINT in tubes, 1/- each, covering approximately 8 sq. ft., or complete cycle frame; suitable for all paintable surfaces. Colours: rich brown, bright red, pink, bright blue, maroon, turquoise, cream, yellow, black, deep green, bright green, mid-grey, white and clear; home trade and export. Obtainable from Handicraft, Hobbies and other shops, or send 1/3 for sample tube and colour card, post free, to sole manufacturers: Starline, Southend, Essex.

NUTS, BOLTS, SCREWS, Rivets, Washers, and hundreds of other items for model engineers and handy-men; s.a.e. for list. Whiston (Dept. PMS), New Mills, Stockport.

HOW TO RE-WIND and service Electric Motors, Generators. Complete Practical Book only 3/- p.p.d. Below:-

10,000 FORMULAS, Processes, Recipes, Trade Secrets. This is the 1,000-page money making and money saving book of the century. Limited number again available. Full approval against payment, 27/6. p.p.d. Below:-

BUILD YOUR OWN PHOTO EQUIPMENT, 12 designs in two books, Enlargers, printers, dryers, timers, etc. 6/-; p.p.d. Below:-

AMERICAN BOAT BUILDERS Annual; 28 boat plans, 8-22ft., and other helpful articles, 7/6; p.p.d. Below:-

TELESCOPES—DESIGN AND CONSTRUCTION, only 3/- p.p.d. Really outstanding American designs at lowest cost to make. Below:-

LATHE HANDBOOK, 3 books in one, 5/- p.p.d., wood-turning, metal turning, metal spinning, ligs, attachments, special operations; 200 illustrations; outstanding, practical, "how-to-do-it" material throughout. Below:-

CAR BODY REPAIRING. Complete A B C course; illustrated; 7/6. p.p.d.; lists free. American Publishers Service (P), Sedgford, Norfolk.

HOUSE SERVICE METERS, credit and prepayment; available from stock. Universal Electrical, 221, City Road, London, E.C.1.

COMPRESSORS for sale, 2½ CFM, 180lbs. sq. in., on metal base, with driving wheel and receiver, price £3; 4 h.p. Heavy Duty Motors, price £3; carriage forward. Wheelhouse, 1, The Grove, Isleworth. (Telephone: Hounslow 7558.)

TYPEWRITERS / D U P L I C A T O R S ; Easiest Terms; Free Delivery Anywhere. Verney Clayton, M.C., Market Rasen, Lincolnshire.

TUFNOL: Rod and Sheet, "Perspex" Coloured and Clear Sheet, Clear Rod, Cements and Polishers, Vulcanised Fibre Sheet, Acetate, P.V.C. and Formica; no order too small; send s.a.e. for price list. Lawrence & Jefferys Ltd., 16, Gloucester Road, Brighton, Sussex, Eng.

NEW TIMBER. Imported Softwood, Quarterings, Boards, Battens, Weatherboards, Greenhouse Bar, etc., cheapest in trade; all sizes stocked. Cannon's (Forest Gate), Dept. P.M., 383, 395, Romford Road, London, E.7.

NEW EX-W.D. fitted Tap and Die Cases to hold 6 13/16in. O/D Dies, 12 Taps, Die Stock, and Tap Wrench, price, including postage, 4/-. Bullers, Printing Office Street, Doncaster.

ARE YOU STUCK ON ELECTRICAL OR RADIO CONTROL? Large stock of Transformers, Rectifiers, Lamps, Rotary Converters, Motors, Technical Books. S.A.E. for bargain lists. Lawrence, 134, Cranley Gardens, N.10. (C.L.I. 664.)

FRACTIONAL HYPERSYNCHRONOUS GEARED MOTORS, 230v. A.C. S/Ph, 50c., final speed 2 r.p.m.; price 12/6 each, plus 1/- postage. Universal Electrical, 221, City Road, London, E.C.1.

COMPRESSOR EQUIPMENT. Miscellaneous Items; catalogue 1/6. Fryce, 157, Malden Road, Cheam.

GRAINING BY TRANSFER. Perfect reproduction oak, walnut, etc. Samples 1/-; complete range 3/-. P.M., DECAÑO CO., 20, Clarendon Road, Jersey, C.I.

STEAM CARS, Launches and small Stationary Units. Dimensioned Drawings include Modern Steam Power Unit for 8 h.p. cars. Magazine, Books; s.a.e. for free lists. "Light Steam Power," Kirk Michael, Isle of Man.

"LIGHT MACHINES FOR WOODWORK," written by Charles Hayward, Editor of "Woodworker," illustrates use of saws, planers, spindles, sanders, powered hand tools. 10/-, post paid from Stobart & Son, Ltd., Handicraft Book Specialists, 9, Victoria Street, London, S.W.1.

LENSES BY THE THOUSAND! Send 2/6 for lists of Lenses, Prisms, etc., Achromatics from 2/6; Special offer.—Kodak Bromide Paper, soft grade, in rolls 10ft. by 9½in., add 3d. per roll postage; Fenner Vee Belts, 46in. long x ½in. section, 2/6 each; Photo-electric Cells, type G.S.18 (new), 2/1 each. Burgess Lane & Company, Sunleigh Works, Sunleigh Road, Wembley. (Wembley: 2378.)

PLATED NUTS, Screws, Washers, Bolts, Soldering Tags, Hank-bushes, Self-tapping Screws, Grub-screws, Socket-screws, Wood-screws; large quantities or gross cartons. List sent post free. Sinden Components Ltd., Dept. E, 117, Churchfield Road, Acton, W.3. (ACORN 8126.)

MULTISTRAND ELASTIC, ½in. thick, 1/2 yard, remnants, 6d. yard; Cellulose paint, stone, green, brown, blue, 5-gallon drums, 40/-; Clear Varnish, 45/- drum; French Polish, 4-gallon drums, 50/-; Bostik, black, 8/6 drums 5/6; Galvanised Wire Sheets, 27in. x 10in., 3 square mesh for lin., 2/-, 25 for 30/-; Perforated Metal Sheets, various, stock rusted, 40/- cwt.; Red Rubber Tubing, ½in. bore, 100ft. 15/-; Fabric-covered Air Pressure Tubing, ½in. bore, 10yds. 12/6; carriage extra. Batley & Co., Gorsey Works, Stockport.

50X ASTRO TELESCOPE KITS, for simple assembly, efficient, 2ins. dia. instrument at 40ins. focus, easily prepared in few minutes. Ready adaptable parts comprising:—(1) Selected 50mm. dia. objective mounted in special, long aluminium cell, exterior stoved instrument black crystalline finish; (2) Turned eyepiece focussing mount; (3) adjustable brass knurled eyepiece, length 4½in., magnification 50 diameters linear equivalent, 2,500X area, shows intricate lunar detail, Saturn's Rings, etc.; (4) test certificate with large self-explanatory drawings, details of simple altazimuth mountings, notes, etc., all parts machine turned precision lenses; numerous testimonials; price 55/-; registered postage and packing 2/6. High Power, 80X Eyepieces, 25/- extra; Polarized Eyepieces for daylight astro and lunar observation, 50X, 32/6 extra; fitted with special half-wave polaroid filter; instructions included. Complete telescopes made to order, prices from 95/- to 115/-; stamp for particulars. Below:-

ATOMIC KITS. Reveals actual splitting of atoms, alpha particle bombardment, transmutation, etc., lasts for centuries, half life period, 1,600 years; modified Crookes spintharoscope; harmless miniature nuclear emitter built between standard micro slides, incorporating target screen and observation window, with viewing microscope, 15/- box, post 6d.; Atomic Slide alone, 10/-, post 6d.; both with instructional data. Below:-

POLARIZING EXPERIMENTAL KITS, containing 6 assorted sizes laboratory grade polarizing screens for simple adaptation to cameras, microscopes, projectors, 3D cinema viewing, making polariscopes, etc., with optical exciters, Photo-elastic "U," etc., 100X area microscope in metal frame, illustrated instructions, detailing application, experiments, 21/- box, post 6d. Below:-

ZAMBONI ELECTRO-STATIC PILES, 1,500 volts, inexhaustible potential for static electric experimenting, charging electroscopes, etc., size 1 x 9½ins., ebonite cylindrical case, fitted with lin. dia. brass electrodes, containing thousands of dissimilar metal discs, no chemical action, with instructions, price 12/6. Post 6d. Below:-

ABOVE KITS from actual makers, unobtainable elsewhere; schools and colleges supplied; terms c.w.o., c.o.d. 1/6 extra postage extra overseas; stamp for lists. J. E. M. Holmes, Scientific Instrument Makers" (Dept. P.M.6), 38, Linden Road, Gosforth, Newcastle-on-Tyne, 3.

1/12 IN. OIL IMMERSION OBJECTIVE, £7/10/- Also various slides, Microscope, 51, Millers Rd., Brighton.

RUBBER MOULDS for Plaster Ornaments from 2/- each. Moulding compound for mould making 8/6 per lb. Granulated ready for use. Metal casting moulds from 3/- each, s.a.e. for list. F. W. Nuthall, 69, St. Mark's Road, Hanwell, London, W.7.

PERSPEX for all purposes, clear or coloured dials, discs, engraving. Denny, 15, Netherwood Road, W.14. (SHE. 1426, 5152.)

SWISS MUSICAL MOVEMENTS for use in cigarette boxes, soft toys, etc., direct from the importer; s.a.e. for price and tune list. Mulco Manufacturing & Trading Co. Ltd., 72, Greyhound Hill, Hendon, N.W.4. Trade supplied.

CASTING MOULDS for lead soldiers, animals, etc. Complete illustrated catalogue, 6d. Sample mould 6/-. G. F. Rhead, Botesdale, Suffolk.

FOR SALE, 180 copies P.M., no duplicates, generally good order. May, 1958-Dec. 1953. What offers? Box No. 122, c/o PRACTICAL MECHANICS.

GLORIOUS, Health-giving Sunshine. Bathe in the wonderfully luxurious Ultra-Violet Infra-Red rays of the Scientific Supertonic Sunlamp and get a marvellous tan. A £7 Sunlamp for only 60/-; s.a.e. brochure. Scientific Products, Shipley, Yorks.

LATEX FOAM UPHOLSTERY. 2ft. 6in. Damask Mattress £7/10/-; carr. 2/-; 14½in. x 13in. x 1½in. Seat Unit, 8/6; carr. 1/-; 24in. x 18in. x 4in., 30/-; carr. 2/-; all shapes and sizes; s.a.e. list. B. & M. (Latex) Sales, 35, Station Road, Addlestone, Surrey. (Telephone: Weybridge 331.)

WATCHMAKERS

LET US SOLVE your repair problem; none too small, none too difficult. If your Watch or Clock can be repaired, we can repair it. Hereford Watch Co., 42, Broad Street, Hereford.

WATCH REPAIRERS, Hobbyists, etc., send s.a.e. for list of Watches, Movements, etc., priced from 9d. each. Loader Bros., Dept. P.M., 36, Milestone Rd., Carterton, Oxford.

RELIABLE TRADE REPAIRS— Balance staffs fitted to movements 7/6; Cylinders 8/6; Hairsprings 7/6; Wheel pivots 5/-. Also Watch Mainsprings 10/- a dozen, buttons 4/6 and stems 4/6 a dozen; 3-day service. B. A. Ball, "Ridgeway," Carlton Avenue, Bognor, Sussex.

RADIO

CAN YOU SOLDER? That's all you need to make a really good radio from guaranteed Osom components. Send 5d. (stamps) to-day for free circuits and lists. Dept. P.M., Osom Radio Products Ltd., 418, Brighton Road, South Croydon, Surrey. (Croydon 5148/9.)

10/6 CRYSTAL RADIO KIT. Build with a screwdriver and pliers. Send P.O. 10/6 plus 6d. postage. Wiring diagrams and illustrated parts list for 6 experimental sets. 1/-, post free. Blanchard's, 13, Gainford Gardens, Manchester, 10.

PHOTOGRAPHY

ENLARGER and Camera Bellows supplied; also fitted. Beers, St. Cuthbert's Road, Derby.

GR ELECTRONIC TIMER,—1.60 seconds, instant push button re-set. Construction kit 70/- P. and P. 2/6, 7 days' approval. S.a.e. details. G.R. Products, 22, Runnymede Avenue, Bristol, 4.

WANTED

WANTED, surplus stocks of Twist Drills, Milling Cutters, Hack-saw Blades, Reamers, Chasers and all kinds of Hand and Cutting Tools. Send details to B. Draper & Son, Kingston Hall Road, Kingston-on-Thames, Cash on delivery.

WANTED: 12 volt Oil Dilution Magnetic Valves, type F.A.W. Cooper McDougall & Robertson Ltd., Chemical Works, Berkhamsted.

ELECTRICAL

BARGAINS FOR ELECTRICIANS. Brand new Cables in 25-100yd. coils: T.R.S. twin 1/044, 42/-; 3/029, 55/6; 3/029 and Earth, 63/3; 7/029 and Earth, 112/6; P.V.C. twin 1/044, 35/-; 3/029, 52/-; transparent P.V.C., 14/36; twin, 15/9; all per 100yds.; Lampholders, 6/6; Switches, 1-way, 16/3; 2-way, 19/- doz. Requests lists. Jaylow Supplies Ltd., 93, Fairholt Road, London, N.16.

BRAND NEW Brooks & h.p. Motors, ball-bearing, 230v., A.C., single phase, 50 cycles, 2,800 r.p.m.; ideal for driving woodworking machines, grinders, etc.; latest type in maker's sealed box; £8/15/-; also Capacitor Type, £9/15/-; carriage paid. F. Blood & Co., Wolsey Bridge, near Stafford.

AMAZINGLY powerful miniature Electric Motors, size 1½in. x 1½in.; drives model boats, trains, gramophones, aeroplanes, radio controls, etc.; 4/5.00 r.p.m.—3 to 6 volts D.C. amps. 06 to 01; original price 1/16, now 8/-, carriage paid. Etna Products Ltd., Dept. P.M., "Highland," Alkington Green, Middleton, Manchester.

HANDICRAFTS

MUSICAL MECHANISMS. Swiss made for fitting in cigarette boxes, etc., 21/- each. Send s.a.e. for complete list of handicraft materials. Metwood Accessories, 65, Church Street, Wolverton, Bucks.

MAKE YOUR OWN MUSICAL BOX. Swiss-made Movements, 22/6; s.a.e. list of tunes; largest stockist in the country. Albert's Music Shop, 45, Heath Road, Twickenham.

CRAFTWORKERS (either sex)! Soft toy assembling; the ideal profitable pastime; details s.a.e. Cuddlycraft Supplies, East Road, London, N.1.

"BUILT-IN FURNITURE," by Arthur Brown, will enable you to modernise and re-space every room in your home. 7/11, post paid from Stobart & Son, Ltd., Handicraft Book Specialists, 9, Victoria Street, London, S.W.1.

"MAKE IT YOURSELF" FURNITURE. Kits of Parts ready for you to assemble. Timber cut and machined to your exact sizes. Call or send for Price Lists. Eames (Wembley) Ltd., (Dept. P.M.), Stanley Works, Stanley Ave., Alperton. (Opp. Dorothy Ave.) Wem. 0034.

WOODWORKING

"THE WOOD TURNING LATHE," an authoritative book by Ray Haines, Department of Vocational Education, New York University. 21/9, post paid, from Stobart & Son, Ltd., Handicraft Book Specialists, 9, Victoria Street, London, S.W.1.

PLYWOOD, 36 x 12 x 3/16, 13/- doz.; 24 x 12 x 3/16, 9/6 doz.; c.p.; s.a.e. for list. Parmount, (Dept. P.M.), Burnley Road, Rawten-stal.

WOOD LATHES, Attachments, Motors and Control Gear, Circular Saw Blades, Spindles or Benches, Turning Tools, etc.; interested? Then send 6d. for illustrated literature, price list and H.P. terms. D. Arundel & Co., Mills Drive, Farn-don Road, Newark, Notts.

EDUCATIONAL

FREE! Brochure giving details of courses in Mechanical and Production Engineering, Draughtsmanship, etc., for the A.M.I.Mech.E., A.M.I.P.E., City and Guilds, and other professional examinations. Train with the Postal Training College operated by an industrial Organisation; moderate fees. Dept. PM30, E.M.I. Institutes, London, W.4.

M.C.C. CORRESPONDENCE COURSES for Craftsmen (Woodwork or Metalwork) give training for London City and Guilds Certificate for teachers. Personal attention by Tutors. Greatest percentage of passes in over 50 years. Write Director, Charnwood, Leslie, Fife, or Regional Secretary, Bushby, Nr. Leicester.

I.P.R.E. TECHNICAL PUBLICATIONS. 5,500 Alignment Peaks for superheterodynes, 5/9; Data for constructing TV aerial; strength meter, 7/6; sample copy "The Practical Radio Engineer" quarterly publication of the Institute, 2/-; membership and examination data, 1/-; Syllabus of 7 postal courses free and post free. Sec., I.P.R.E., 20, Fairfield Road, London, N.8.

(Continued on next page)

(Continued from previous page)

BOOKS

NEW AND USED Correspondence Courses. Educational Books. bought, sold. Catalogue. Courses. 28, Dean Road, London, N.W.2.

MODEL DEALERS

HOBBIES LTD. have over 50 years' experience of catering for the needs of modelers, handymen and home craftsmen. Branches at 78a, New Oxford Street, London and in Birmingham, Glasgow, Manchester, Leeds, Sheffield, Hull, Southampton and Bristol. Head Office, Dereham, Norfolk.

HOBBIES

SHIPS IN BOTTLES—The constructional kit that tells you how to make them; build for pleasure or for profits; kits 6/- ea. from Hobbies Ltd., and model shops. Cooper-Craft Ltd. The Bridewell, Norwich. "THE AMATEUR'S WORKSHOP," by Ian Bradley, shows how to equip and maintain the workshop with machine tools and metalworking hand tools. 8/9, post paid, from Stobart & Son, Ltd., Handicraft Book Specialists, 9, Victoria Street, London, S.W.1.

MISCELLANEOUS

BOOKLETS. "How to use ex-Gov. Lenses and Prisms," Nos. 1 and 2, price 2/6 ea.; ex-Gov. Optical lists free for s.a.e. H. English, Rayleigh Road, Hutton, Brentwood, Essex. **BUILD YOUR OWN REFRIGERATOR,** all components available at reasonable prices. Frigidaire flowing cold units £5; small units, Kelvinator, etc., £4; 1 h.p. heavy duty Motors, £3; Chrome Cabinet fittings, new, £1; money back guarantee; s.a.e. for list and schematic diagram. Wheelhouse, 1, The Grove, Isleworth, Middx. (Phone: Hounslow 7558). "FORTUNES IN FORMULAS," 900-page American book of formulae. American technical, hobby and other books covering every interest. Stamp for lists. Herga Ltd. (Dept. P2), Hastings.

WORK WANTED

IS THERE A METAL PART YOU WANT MAKING? A Spindle Turned, a Thread Cut? We do Turnings, Milling, Drilling, Press Work, etc.; 1 off or quantity; send drawing with stamped-addressed envelope for free estimate to T. A. Winter, Electrical & Mechanical Engineers, 66, Stonhouse Street, London, S.W.4.

POTTERY

Potter's wheels from £24. 3 kW. Electric kilns from £12 to £50. Also a wide range of pottery materials. Write for illustrated catalogue. **MILLS & HUBBALL, Ltd.,** 244, Borough High St., London, S.E.1.

CABLE CHEAPER IN SMALL COILS
No coil under 25 yds. unless requested. All prices per 100 yd. lot.
3/029 7/029
TWIN FLAT 1/044 3/029 W/E W/E
Rubber ... 42/- 53/- 63/- 109/-
Plastic ... 38/- 52/- 61/- 107/-
Single V.I.E. 18/- 33/- 36/-
Earth Wire 7/029 tinned copper 8/8100ft. lot.
If less than 100 yd. lot wanted add 5%. Add part carriage to small orders please. Send for lists of flexes, all cables, wiring accessories. **BRITISH DISTRIBUTING (Desk M),** 591, Green Lanes, London, N.8.

GOVERNMENT

SURPLUS BARGAINS

LANDING LAMP MOTORS exactly as described for SELF-OPENING GARAGE DOORS—"Practical Motorist," Aug. '54 (copy of article sent with motor). 12/24v. D.C. also 30 v. A.C., drive via gear and quadrant giving lateral movement of about 2in. and reverse. Each 25/-, post 1/9.
HAND GENERATORS. Complete with handle and 72/1 gearbox. Output 28 volts and 300 volts. As described for WASHING MACHINE in "Practical Mechanics" Aug. '53 and WRINGER Mar. '54. Each 25/-, post 1/9.
EPICYCLIC GEAR MOTORS. (Aircraft cowling motors) operate through 4-stage 625/1 gear (5-25-125-625 one or more stages easily locked to give any of these ratios) 24 v. D.C., 5 amps. 12 v. D.C., app. 4 amps. also operate 16/30 v. A.C., app. 5.7 amps. Each 25/-, post 1/9.
ELECTRIC FANS. New in maker's boxes. 230-250 v. A.C. 7 1/2 in. Blades. Suitable extraction or circulation. Bargain at 50/-, post 2/-.
TELEPHONE HANDSETS. Streamlined P.O. type suitable intercom system. Each 17/6, post 1/6.
PRESSURE TANKS (R.A.F. Oil Reservoirs). Each 5/-, post 1/6.
Send 3d. Stamp for list of MOTORS, TELEPHONES, TRANSFORMERS, PUMPS, LAMPS, SWITCHES, BOXES, etc., etc. Hundreds of Bargains.

MILLIGANS

24, HARFORD ST., LIVERPOOL, 3.
Money Back Guarantee.



Build your own SPRAYING PLANT

BRAND NEW Heywood Bendix Compressors, with Driving Shaft, 40/- each, 2/6 Carr.
Approx. 2 c. ft. at 600 r.p.m. & 100 lbs. per sq. in.

TANKS, complete with gauge, taps, etc. Tested to 400 lb. per sq. in. on platform.
40/-, Carr. 6/-

C. H. VINCENT

47/49 Essex Road, Islington, London, N.1.
Canonbury 3720

ROGERS,

31, Nelson Street, SOUTHPORT

TEST METER CONSTRUCTION UNITS. Sensitive movement in case with scale 6in. x 4in. Calibrated 10 to 10,000 ohms, and with volt ranges. Unit with Scale and Detail Sheet ... 9/9
Assorted Springs, 50 in box ... 3/-
Grinders, A.C. mains. Twin ended, 45/-
Self-Tap Screws, 100 asstd. ... 3/-
Thread Gauges, 28 arms. ... 4/9
Saw Bench Tops, with Ball Race, Spindle, Pulley, etc., 18in. x 10in. 52/6
Grommets, 50 assorted ... 1/9
Rotary Files, 12 in case ... 11/9
D.C. Generators, 6 v., 12 v., 250 v. 12/6
3in. Green Grit Grinding Wheels 4/9
Admiralty Rotary Compressor Plants, complete, less motor £5.7.6
May we send our list of hundreds of interesting items, 11d. stamp please.

RATCHET & REVOLUTION COUNTERS



Ask for Leaflet No. 18/7
Speeds up to 6,000 r.p.m.
B. & F. CARTER & Co., Ltd., Bolton 5

SENSATIONAL NEW STYLE



MOTOR CYCLE COVERS

Made from heavyweight ONLY "VYNYL" sheeting. These superb motor-cycle covers have transparent inserts front and rear to permit night parking with lights visible. Welded seams, completely waterproof. These superb covers are shaped to ensure a snug fit, thereby avoiding use of tapes and loops. Fits all cycles up to 500 c.c. Folds very compact.
MARCUS STORES (51), GRAVESEND

THE FAMOUS

HARRIS ELECTRIC WELDER

and Complete Kit

For Welding, Soldering, Brazing and metal extraction & repairs in the home, on the car or cycle. Instant heat 6,000W P. Works from 6v. or 12v. car battery or transformer from A.C. mains. Complete kit of Welding Tools, 9 ft. cable, clip carbons, cleansing fluid, fluxes, filler rods, goggles, instructions, hints. Thousands in daily use. As supplied to Dept. of H.M. Government. I.C.I., Standard Telephones, etc. Welds all Metals. Up to one-eighth inch. C.O.D. IF REQUIRED. Obtainable only from **HARRIS ENGINEERING CO. (Dept. P.M.)** 269 Kingsland Road, London, E.2. **53/6** Post Free.

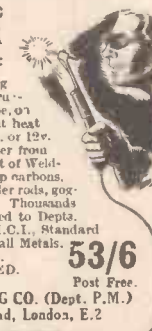

GENERAL CERT. OF EDUCATION

THE KEY TO SUCCESS & SECURITY

Essential to success in any walk of life! Whatever your age, you can now prepare at home for the important new General Cert. of Education Exam., on "NO PASS—NO FEE" terms. You choose your own subjects—Educational, Commercial or Technical. Recently announced big extension of subjects gives everyone chance to get this valuable Certificate.

SEND FOR FREE 134 PAGE BOOK
Full details of how you can obtain the General Cert. are given in our 136-page Guide—Free and without obligation. Personal advice on request. Write today. Dept. 160, S.O.C. 29-31, Wright's Lane, London, W.8. "NO PASS—NO FEE"

HIGH QUALITY TOOLS

For the Craftsman
Terms as low as 2/6 per week. Send 1/- for catalogue containing over 400 items.

H. J. BOULTING LTD.
21, Wellington Street, Leicester

ELECTRIC WELDING PLANT

Large stock of new and unused surplus Arc and Spot Welders by leading makers. Prices from £23 10s.—£70. Outputs from 85 amps. max. to 400 amps. max. Sets for 220/250 volts with low mains consumption available in wide range. Catalogue from: **HARMSWORTH, TOWNLEY & Co.,** 1, Brook Road, Manchester, 14.

Offers Ex-Stock

ALL CARRIAGE PAID AND MONEY BACK GUARANTEE

MINIATURE ANGLE LAMPS

Take Standard Low Voltage Bulbs. Just the job for Boat or Caravan, Workshop or Darkroom. Fix anywhere by Clip Grip or stand firm on flat surface.

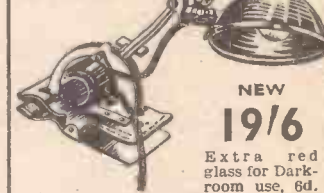

NEW 19/6
Extra red glass for Dark-room use, 6d.

COWL GILL MOTORS. The motor with 100 uses. 24 v., will run on 12. 4-stage reduction gear 625/1 magnetic brake and reversing switchgear, 26/9.

ASTRO COMPASSES for conversion to many purposes (see September "Practical Mechanics"), 9/11.

R.A.F. COMPASSES, ALTIMETERS AND OTHER INSTRUMENTS—wide variety from 20/-.

GENERATORS for Welding, etc. 200 amps 23 volts, £9/10/- Others, lower output, from £8.

LOW VOLTAGE MOTORS (D.C.)—G geared, etc., from 15/-.

GYRO SIGHT UNITS (U.S.A.)—Comprising precision-made motor and gyro driving rotating mirror, two 2in. lenses, mirrors, anti-glare screens, gearing, etc., in very useful metal housing, fraction of original cost, 24 volts D.C. 35/-.

And a host of other Ex-British and U.S. Air Services Surplus.

SEND YOUR ENQUIRIES TO:



(DISPOSALS DIVISION)
Blackbushe Airport, Camberley, Surrey

ACCURATE HARD HITTING
Webley
AIR PISTOLS
AIR RIFLES - ACCESSORIES
Write for catalogue WEBLEY & SCOTT Ltd. 106, WEA-MAN ST., BIRMINGHAM 4, ENGLAND

PORTAS 4 1/2" x 37" S.C. LATHE
Cast Iron Tray and Peds in 2 lengths.
Charles Portas & Son, Dept. P.M. Buttermere Works, Sheff. 8.

NON-FERROUS METALS

- BRASS
- COPPER
- PHOS. BRONZE
- ALUMINIUM
- DURALUMIN
- NICKEL-SILVER
- TIN-PLATE
- ZINC-SHEETS
- GUN METAL
- TEE
- RODS
- TUBES
- STRIPS
- SHEETS
- BLANKS
- ANGLES
- RIVETS
- CHANNEL

CITY METAL WORKS
ESTABLISHED 1800
CENTRAL 5760, 5769

STANTON BROS. (METALS) LTD.
73, SHOE LANE, LONDON, E.C.4

THE MOST COMPREHENSIVE STOCK AVAILABLE
WHOLESALE AND RETAIL

Trade Notes

New Saw Attachments

BLACK AND DECKER, LTD., Harmondsworth, Middlesex, recently announced details of new features connected with their range of "Utility" electric tools.



Black and Decker lathe saw table.

First, there are two new saw attachments which can quickly convert the sander-polisher or $\frac{1}{2}$ in. drill into a portable or bench saw. The $\frac{1}{2}$ in. portable saw attachment turns either tool into a powerful portable saw. Light in weight, entirely safe in use, this labour-saving attachment is easy to fit. Its $\frac{1}{2}$ in. diameter blade has a depth of cut of $1\frac{1}{2}$ in.—adjustable bevel cutting up to 45° , $\frac{1}{4}$ in. deep—adjustable rip fence for widths up to $5\frac{1}{2}$ in. The lathe saw table attachment increases the versatility of the B. and D. lathe, converting it quickly into a rigid saw bench. Fitted with automatic moving safety guard, its $\frac{1}{2}$ in. diameter blade has a depth of cut of $1\frac{1}{2}$ in. and rip fence adjustable for widths up to 9 in.

For the first time B. and D. electric tool kits are available on hire purchase. Black and Decker, Ltd., have introduced five different home workshop outfits, which are available under this scheme.

A third introduction with which B. and D. have associated themselves is the new "Easi-Bild" woodworking patterns. These consist of full size paper patterns which one traces on wood, cuts and assembles just like a dress-making pattern. There is a range available from a workbench to a child's rocking horse.

P.B.K. Canoe Plans

FROM P. W. Blandford, Quinton House, Newbold-on-Stour, Stratford-on-Avon, Warwick, we have received a price list of the canoe designs and various accessories which they supply. The designs listed (there are 16 of them) are for rigid canvas-covered canoes, rigid plywood-skinned canoes and folding canoes of various types and sizes. Prices for complete instructions and drawings range from 6s. 6d. to 12s. Accessory drawings, covering

the construction of such things as paddle, spray cover, trolley, rudder, sailing gear, etc., are available for two or three shillings and photographs for 1s. each. The firm of P. W. Blandford claims to be able to supply any nautical book in print and supplies, in addition, a wide range of accessories and materials—from an outboard motor to sail eyelets. For any further information write to P. W. Blandford at the above address, enclosing a stamped, addressed envelope.

A New Shelf Support

THIS new wall fitting is being marketed by Oznal Couplings, Ltd., 65, High Street, Sutton, Surrey. Simplicity and strength are the two main features and they are made from pressure diecastings in Mazac 3 and are almost invisible. The physical proportions and method of fixing should be apparent from the sketch. The shelf fittings are hooked into the wall fittings and the shelf held in position by its own weight. The couplings are rustless and can be painted or enamelled, do not damage the walls and are instantly removable, thus making cleaning and decorating work easier. They are suitable for use for everywhere in the home or elsewhere where hygiene, neatness and strength are required.

Rustless cadmium-plated screws are provided, and for supporting more than normal weights an arm assembly unit, also made in Mazac 3, is available. This unit is also instantly removable.

The whole set, including the arm assembly unit, Rawlplugs, screws and instructions, is provided complete with carton for 6s. Separate units may be bought as follows: Couplings with cadmium screws and Rawlplugs and instructions, 3s. 3d.; one arm assembly unit with cadmium screws and

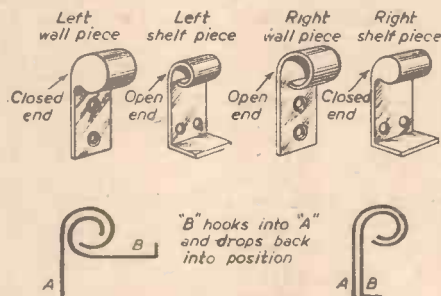

The Oznal couplings and how they fit together.

Rawlplugs, 3s. 3d. All are packed in smart cartons.

Eclipse Hacksaw Frame

THE tubular design of the "Eclipse" 20T frame is familiar to engineers and needs little description, but now it appears in a different form. The new design of the handle gives greater comfort to the hand and

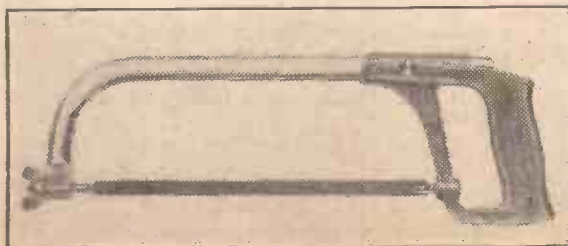

The new Eclipse hacksaw frame.

directs the pressure at the angle required for maximum efficiency. The adoption of a tubular bow of oval section provides greater strength and rigidity and a clearer view of the work.

The frame is supplied complete with an "Eclipse" high speed steel hacksaw blade. It is made by James Neill & Co. (Sheffield) Ltd., Napier Street, Sheffield, 11.

A Miniature Relay

MODERN developments have brought about the need for a multi-purpose relay which is small in size and yet strong and

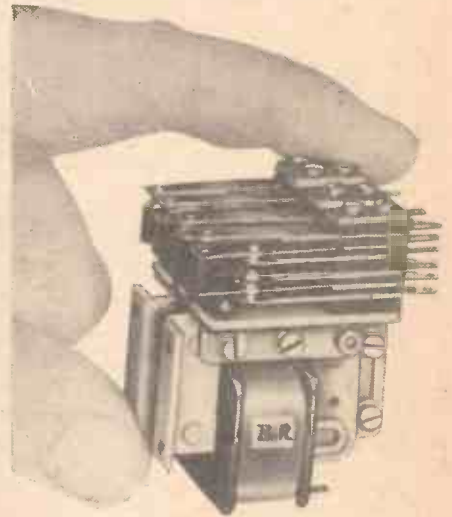

The miniature relay.

reliable coupled with a long life and ample safety margins. Besson and Robinson, Ltd., 6, Government Buildings, Kidbrooke Park Road, London, S.E.3, have designed such a miniature relay. In spite of its small physical dimensions, many of the constructional refinements which are normally only found in high quality full size units, including a laminated armature and frame, a stainless steel armature shaft, "Oilite" bearings, and buffered contacts, are incorporated. Among the design features are rapid operations on both A.C. and D.C., inherent freedom from buzz while operated on A.C., heavy contact pressure, and low coil consumption. The relay is particularly suitable for close stacking in applications where many millions of operations may be required.

Belleville Washers

THE range of these washers and their uses are described in a leaflet just published by the makers, Messrs. Herbert Terry and Sons, Ltd., Redditch, England. It also contains prices and load-deflection charts.

A Hand Weaving Loom

INSTRUCTIONS and a plan for making a 9 in., 12 in., 15 in. or 20 in. loom are available from "The Handweaver and Spinner," Dane John Oast, Canterbury, and lists of materials required and suppliers are also included. We understand that a correspondence course is available also on the subject of handweaving.

"Negro" Accessories

FROM Neville Brown and Co., Ltd., we have received a catalogue of their famous Negro photographic equipment and products of Aldis, Betram, Carl Braun, Cremer, Cyldon, Dallmeyer, Ferrania, Robot, Wray and many others which they distribute. This firm does not deal directly with the public, but the Negro catalogue and all the Negro lines may be obtained through an approved photographic dealer.

Your Queries Answered



RULES

A stamped, addressed envelope, a sixpenny, crossed postal order, and the query coupon from the current issue, which appears on the inside of back cover, must be enclosed with every letter containing a query. Every query and drawing which is sent must bear the name and address of the reader. Send your queries to the Editor, PRACTICAL MECHANICS, Geo. Newnes, Ltd., Tower House, Southampton Street, Strand, London, W.C.2.

Periscope Design

I WISH to make a small periscope which is required to be used out of a window to view a 10ft. square area of street below. It is to work horizontally from a first-floor window and to protrude through the window frame.

I would like this to be made of 1in. to 1½in. diameter tubing and to be adjustable in length, one tube sliding inside the other.

I have some 1in. square mirrors of good quality, which could be used in the tube.—G. W. Foreman (S.W.16).

WITH two plain, flat mirrors in your periscope, both fixed in tubes of from 1in. to 1½in. diameter, it would be impossible to see an area of the footpath below of more than about 4in. square, possibly not quite so much as that. In order to view the amount of pavement which you desire to see, all that you will have to do is to substitute for the outer mirror a convex one retaining the flat mirror at the inner end. Such a convex mirror can be cut from a driving mirror of a car, which car fitting would provide sufficient domed glass for three or more periscopes. The smaller the camber radius of the mirror the greater will be the area of pavement seen. We should think that a normal driving mirror would have a curvature sufficiently small to show footpath measuring about 10ft. or 12ft. in area. Set both mirrors at the same angle of 45 deg., the inner flat one looking upwards and the outer curved one downwards.

Obtaining High Frequency Current

I WISH to pass an electric current through a large volume of water. I shall need high voltage with low current and, to prevent dangerous shocks, it would have to be high frequency.

Please state how high frequency current is obtained. I have a 230-volt generator, A.C., engine-driven and would like to know what else I require to make alive my static tank approximately 12ft. by 16ft. by 4ft. deep.—E. B. Hooper (Pemb).

THE resistivity of water depends on its mineral content. Water drawn from public supply mains with a normal content of

salts, usually found in solution, may have a resistivity of 800 to 2,000 ohms per inch cube. Rainwater supplies may have a resistivity of 4,000 to 5,000 ohms per inch cube.

High frequency currents may be produced by special high frequency alternators, which have been built for frequencies up to 100,000 cycles per second. A more common method these days is to use a valve oscillator circuit. The only way of obtaining a higher frequency of output from your alternator is to rewind it with a larger number of poles, which would probably be impracticable; or to drive it at a higher speed, the frequency being proportional to the number of poles and speed. The increased frequency obtainable by increase of speed will be very limited due to increased centrifugal stresses in the rotating parts, such stresses being proportional to speed². At increased speed you may require to connect a resistance in the field circuit, if the machine has a direct coupled or integral exciter, in order to limit the field current to its normal value and to avoid overheating of the field coils.

Possibly you could use a high current at low voltage for your unstated purpose by means of electrodes of large area mounted very close together.

OO Gauge Points and Signals Motors

I WISH to modernise an OO gauge electric railway, by making up a few electric signals and some points motors. Could you please give me any instructions, etc., how to make the little solenoids to

operate (1) OO gauge signals; (2) OO gauge points both on 12 volts D.C.?

I should like the signals solenoids to be as small as possible and the points motors for attachment under the baseboard to operate a crank through and above the board. The throw of these motors is about 5/32in.—F. Hardstone (Tooting).

IF you can consult a copy of "Indoor Model Railways," by E. W. Twining (George Newnes, Ltd., London), now, unfortunately, out of print, you will be considerably helped in your scheme of making electrically-operated points and signals.

Solenoids may very well be all placed underneath the baseboard, not only for points but for signals also. These latter are

Readers are asked to note that we have discontinued our electrical query service. Replies that appear in these pages from time to time are old ones and are published as being of general interest. Will readers requiring information on other subjects please be as brief as possible with their enquiries.

mounted vertically with the rod, operating the signal arm, passing straight down through the base and attached to the sliding core of the solenoid. This core would normally be at the bottom of the coil and when current is switched on through the coil the core would be lifted and with it the rod, so depressing the arm to the down (or up, in the case of upper quadrants) or off position.

The bobbins can be made of paper-rolled tubes to enclose the cores, which cores should be of ½in. diameter soft iron rod, the tubes would then have a diameter of 9/32in. inside, their lengths can be ½in. to ¾in. Cheeks, cut from Bristol board having a diameter of ½in., are glued on the tubes at each end and the bobbin so formed is wound with No. 40 enamelled or silk-covered wire. Attachments to the baseboard can be made by gluing on the cheeks small pieces of wood. Before winding, the whole of the card, paper and wood should be well coated with thick shellac varnish.

The points solenoids will have to be mounted horizontally and so the cores will need to be supported in sliding; this can be arranged by fixing an extension wire in the back end and providing metal brackets back and front in which the extension and the point rod will slide. The size of these cores and coils will depend upon the power required to move the points; it would be as well to make them a little larger than those for the signals.

Preserving Flowers

I HAVE seen pictures advertised, composed of woodland flowers and plants. Can you tell me how these flowers and plants are preserved without discoloration?—R. Longhurst (Grave-send).

FLOWERS and plants will rapidly fade and turn brown when exposed to light, no matter in what way they are preserved. This is because the colouring matters of flowers and plants in general are notoriously unstable to light. We suspect that the pictures composed of flower and plant parts to which you refer have been artificially dyed on making-up.

The very best method of preserving these
(Continued on page 136)

THE P.M. BLUE-PRINT SERVICE

12FT. ALL-WOOD CANOE. New Series. No. 1.
3s. 6d.*

10-WATT MOTOR. New Series. No. 2, 3s. 6d.*
COMPRESSED-AIR MODEL AERO ENGINE.
New Series. No. 3, 5s.*

AIR RESERVOIR FOR COMPRESSED-AIR
AERO ENGINE. New Series. No. 3a, 1s.

"SPORTS" PEDAL CAR. New Series. No. 4, 5s.*

F. J. CAMM'S FLASH STEAM PLANT. New
Series. No. 5, 5s.*

SYNCHRONOUS ELECTRIC CLOCK. New
Series. No. 6, 5s.*

ELECTRIC DOOR-CHIME. No. 7, 3s. 6d.*

ASTRONOMICAL TELESCOPE. New Series.
Refractor. Object glass 3in. diam.
Magnification X 80.
No. 8 (2 sheets), 7s.*

CANVAS CANOE. New Series. No. 9, 3s. 6d.*

DIASCOPE. New Series. No. 10, 3s. 6d.*

EPISCOPE. New Series. No. 11, 3s. 6d.*

PANTOGRAPH. New Series. No. 12, 1s. 6d.*

COMPRESSED-AIR PAINT SPRAYING
PLANT. New Series. No. 13, 7s. 6d.*

MASTER BATTERY CLOCK.*
Blue-prints (2 sheets), 3s. 6d.
Art board dial for above clock, 1s.

OUTBOARD SPEEDBOAT.
10s. 6d. per set of three sheets.

LIGHTWEIGHT MODEL MONOPLANE.
Full-size blue-print, 3s. 6d.

P.M. TRAILER CARAVAN.
Complete set, 10s. 6d.*

P.M. BATTERY SLAVE CLOCK, 2s.
"PRACTICAL TELEVISION" RECEIVER
(3 sheets), 10s. 6d.

P.M. CABIN HIGHWING MONOPLANE.
1s.*

P.M. TAPE RECORDER
(2 sheets), 5s.

The above blue-prints are obtainable, post free, from Messrs. George Newnes, Ltd., Tower House, Southampton Street, Strand, W.C.2.

An * denotes constructional details are available free with the blue-prints.



Beau Nash modelled in 'Plasticine'

There are so many practical uses for

Plasticine

—always keep some of this handy modelling material on your bench.

From stores and stationers, in 16 attractive colours

HARBUTT'S PLASTICINE LTD.

Inventor: and Sole Manufacturers

BATHAMPTON, BATH, SOMERSET

SPARKS' DATA SHEETS are "PLANNED PLANS"

"Planned Plans" means that every detail is shown in the simplest possible manner with the greatest clarity, by means of bold Black and White Full Size diagrams. These are but two of the very important differences between Sparks' Data Sheets and other "Constructional" sheets and pamphlets.

Plus **2/6** 2½d. Stamp.

Battery Operated Designs.

- LO/23. 1-V. Portable. Med. Waves ('phones)
- LO/31. 2-V. Portable. M/L. Waves.
- LO/30. 2-V. Set. M/L. Waves. Very Popular.
- LO/34. 3-V. Ditto. Det. plus 2 L.F.
- LO/35. 4-V. T.R.F. M/L. Waves. Good Range.
- LO/21. 3-V. T.R.F. M/L. Waves.

Short-Waves.

- LO/42. 1-V. S.W. Receiver. Plug-in Coils.
- LO/43. 2-V. Ditto. Greater Range and Power.

A wide range of A.C. and AC/DC Designs is available, from a 2-Valve plus Rect., to a 9-Valve Radiogram, to suit all requirements.

THE MULLARD 10W. A.C. AMPLIFIER

MS/LO/44. The Sparks' Data Sheet (27 x 20) of this outstanding Mullard circuit, shows every constructional detail of a Tested Simplified modern layout, having a separate Control Panel. Fully Tested. Data Sheet, etc., 3/9 Post Free.

MANY OTHER DESIGNS AVAILABLE Send 2½d. Stamp for Latest List. **COMPONENTS AND DRILLED CHASSIS SUPPLIED**

L. ORMOND SPARKS (M) 5, COURT ROAD, SWANAGE, DORSET.

RADIO SUPPLY CO. (Leeds) Ltd. 32, The Calls, Leeds, 2

Terms: C.W.O. or C.O.D. over £1. Postage 1/- extra under 10/-; 1/6 extra under £2; 2/- extra under £3.

All Goods guaranteed. Catalogue 6d. S.A.E. enquiries.

R.S.C. BATTERY CONVERTER KIT.—A complete kit of parts for the construction of a unit which will replace both H.T. Battery and L.T. Accumulator where 200-250 v. A.C. Mains supply is available. Outputs fully smoothed are 120 v., 90 v., 60 v., 40 mA. and 2 v. at 0.4 a. to 1 amp. for all normal Battery Receivers. Only 48/9. Or assembled ready for use 8/9 extra.

R.S.C. BATTERY SUPERSEDER KIT.—All parts to assemble a unit (housed in metal case approx. 5½ x 4 x 1½ in.) to replace H.T. and L.T. Batteries in ALL DRY RECEIVERS when mains supply of 200-250 v. A.C. is available. Outputs fully smoothed 90 v. 10 mA., 1.4 v. 250 mA. For 4 valve sets only 35/9, or ready for use 42/6.

H.M.V. LONG PLAYING RECORD TURNTABLE WITH CYRSTAL PICK-UP.—(Sapphire Stylus.) Speed 33½ r.p.m. For A.C. mains 200-250 v. Brand New Cartoned and Perfect. Only £31/9/6, plus Carr. 5/-. Limited number only. (Normal price £8 approx.)

BATTERY CHARGER OR 12 V. D.C. SUPPLY UNIT. For Electric Train. Assembled in strong steel case. Will charge 6 v. or 12 v. battery at 1 amp. For mains 230-250 v. 50 c/cfs. 19/6.

R.S.C. BATTERY CHARGER KITS.—For A.C. mains 200-230-250 v. operation. Kit comprises Mains Transformer, F.W. Selenium Rectifier Fuses, Fuseholders, etc., and Louvred Black Crackle Case.

6 v. 2 a. ... 25/9
6 v. or 12 v. 2 a. ... 31/9
6 v. or 12 v. 4 a. ... 49/9

Supplied assembled and tested, 6/9 ex. **HEAVY DUTY BATTERY CHARGER KIT.** For normal mains input, 200-250 v. 50 c/cfs, 3 outputs totalling 35 amps. 12 v. 20 amp, 12 v. 10 a., 6 v. 5 a. Consists of mains trans., 4 F.W. (Bridge) rectifiers, 3 meters, 3 rheostats, 6 terminals, 6 Sylelock fuses and circuit, £11/19/-. plus carr. 10/-. Or assembled ready for use in well-

ventilated case, £15, plus 15/- carr. **PLESSEY 3-SPEED MIXER AUTO-CHANGERS** with high impedance magnetic pick-up with duo point alloy stylus for long playing or standard records. (Will play 2,000 records before replacement stylus required.) Brand new, cartoned, guaranteed. Limited stocks at only 10 gns., plus 5/- carr. **HEAVY DUTY EX. GOV. TRANSFORMERS.**—Suitable soil heating; spot welding, etc. Primary 200-250 v. 50 c/cfs. Sec. 0-11-22 v. 30 amp., 72/6; or Sec. 0-16-18-20 v. 35 a., 79/6.

AMMETER.—G.E.C. 2 in., M/c 0-5 amp., 11/9.

SELENIUM RECTIFIERS
2/6 v. ½ a. H.W. ... 1/9
6/12 v. ½ a. H.W. ... 2/9
6/12 v. 1 a. F.W. (Bridge) ... 5/9
6/12 v. 1½ a. F.W. (Bridge) ... 7/9
6/12 v. 2 a. F.W. (Bridge) ... 9/9
6/12 v. 3 a. F.W. (Bridge) ... 12/3
6/12 v. 4 a. F.W. (Bridge) ... 14/9
6/12 v. 6 a. F.W. (Bridge) ... 19/9
6/12 v. 10 a. F.W. (Bridge) ... 35/-
250 v. 50 mA. H.W. ... 5/9
250 v. 80 mA. H.W. ... 7/9

VARIABLE RESISTORS.—10 ohms 3 amps., 8/9; 0.4 ohm 25 amps., 8/9; 60 ohms 1.5 amps., 11/9; suitable for speed control battery chargers, etc.

R.S.C. FILAMENT TRANSFORMERS.—Primaries 200-250 v. A.C. 50 c/cfs 6.3 v. 1.5 a., 5/9; 12 v. 1 a., 7/11; 6.3 v. 2 a., 7/6; 12 v. 3 a., 17/6; 6.3 v. 3 a., 9/9; 24 v. 1.5 a., 17/6; 0-4-6.3 v. 2 a., 7/9; 6.3 v. 6 a., 17/6.

R.S.C. CHARGER TRANSFORMERS.—Primaries 200-230-250 v. A.C. 50 c/cfs 0-9-15 v. 1½ a., 11/9; 0-9-15 v. 6 a., 22/9; 0-9-15 v. 3 a., 16/9; 0-9-15 v. 4 a., 18/9; 0-11-22 v. 15 a., 45/-. **EX GOV. ACCUMULATORS (NEW).**—2 v. 16 A.H. with Non-spill Vents, 5/9.

EX. GOV. AUTO-TRANSFORMERS.—50 c/cfs 15-10-5-0-195-215-235 v. 500 watts, 27/9.

HAND GENERATOR BATTERY CHARGER.—These fine instruments will boost a "PLAT" battery to enable starting cold mornings. They are rated at 6 volts at 120 r.p.m., will give up to 18 volts at about 4 amps. If turned faster. An ideal stand-by. Can be also easily converted into WIND CHARGERS as per "P.M." article. Has handle for turning, cut-out, output sockets, all contained in strong metal case, ready for use. New, in makers' cartons, 30/- each, carriage 7/6.

ELECTRO-MAGNETIC COUNTERS.—P.O. Subscriber Type. Has 3 ohm coil, will count to 9999, will operate off any low volt battery supply, from 3 volts up. Would act as remote counter. 5/- each, post 9d.

HIGH RESISTANCE HEADPHONES.—Good condition, 4,000 ohms, limited quantity. 8/6 each, post 1/-. **TELEPHONE SETS.**—Ideal Christmas present. Consist of two microphones or earphones, with 8 yards twin flex, speech enervised. No batteries required. Will give speaking communication up to 500 yards. Make good baby alarm or remote listener, new, 12/6 each, post 1/-; 120/- dozen, carriage 3/6.

GEAR UNITS.—These are bevel geared and make a complete back axle for model car, size approx. 6in. long by 2½in. wide. Space to fit wheels. 1/6 each, post 9d.

UNIVERSAL COUPLERS to fit above, 1/- each extra.

U.S.A. THROAT MICROPHONES. Carbon type, 1/6 each, post 4d.

BATTERY CHARGING UNITS.—Consists of 1½ amp. full-wave rectifier, with matched transformer mounted on wood base. Will charge 4-6 or 12 volt car battery. Ready for use, these can also be used for train sets or other models. 30/- each, post 1/2.

P.O. RELAYS.—Type 3,000, with 2,000 ohm coil, single pole 1 make. 3/6 each, post 7d. Another Type 3,000 with 300 ohm coil D.F. 3/6 each, post 7d.

SELENIUM RECTIFIERS.—4 amp. full wave, new, 15/- each, post 1/-. **PROJECTION UNITS.**—Contains high-grade Dalmeyer lens, 40 mm. F.L.3.5, 24 v. 15 w. lamp, chromed reflector, dark ground concave glass with sighting hair-line. 10/- each, post 1/-. Many other interesting items. Send 6d. for new catalogue.

THE SCIENTIFIC INSTRUMENT CO.

16, HOLLY ROAD, QUINTON, BIRMINGHAM, 32. Callers welcomed at 353, Bearwood Road, Smethwick. Phone: WOO 3166.

WOLF HOME CONSTRUCTOR EQUIPMENT

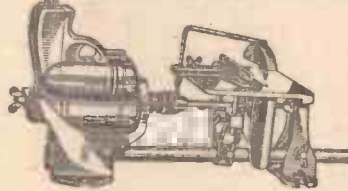

← THIS CAN BE YOURS FOR 25/1 DEPOSIT AND 8 MONTHLY PAYMENTS OF THE SAME AMOUNT. (CASH PRICE £10.5.0) Other items as follows:—

	Cash Price	Deposit of	8 Monthly Pymts. of
Wolf 1in. Electric Drill	£5.19.6	or 14/8	and 14/8
Drill Stand	£3. 4.6	" 7/11	" 7/11
Sanding and Polishing Kit (including Drill)	£7. 0.6	" 17/2	" 17/2
Lathe kit (complete with Drill and Tools)	£10.17.0	" 26/7	" 26/7
No. 5 Saw Set	£2.19.6	" 7/4	" 7/4
No. 8 Fretsaw Set	£3.15.0	" 9/2	" 9/2
Wolf Cub Complete Outfit (exc. Fretsaw)	£16.17.8	" 41/3	" 41/3

We will also supply accessories of your own choice over 30/- in value and quote you our terms. Did you know we also supply Burgess Vibro Sprayers, Vibro Tools, Bridges and B. & D. equipment, X-Acto Kits, Battery Chargers, Headlamps, Car Heaters, Valve Reseating Outfits etc., etc., all on the same advantageous easy terms? Send for quotations and leaflets.

SEND YOUR P.O. TO DESK 86

LAFCO COMPOUNDS, LTD., 3, CORBETTS PASSAGE, ROTHERHITHE NEW ROAD, LONDON, S.E.16. Telephone: BERmondsey 4341, Ext. 1.

Tipped with 100% TUNGSTEN CARBIDE

MASON MASTER

ARE THE BEST YOU CAN BUY

AND TO BE ON THE SAFE SIDE USE **MASO-PLUGS** FOR FIXING

Accept no substitute for masonry drilling.

JOHN M. PERKINS & SMITH, LTD., BRAUNSTON, Nr. RUGBY Telephone: Braunston 238. Telegrams: Drills, Braunston Rugby.

Picture Marquetry



INN SIGNS SERIES

EACH INN SIGN SET CONTAINS MATERIAL FOR TWO COMPLETE SIGNS



Size of each Sign: Approx. 4½ in. x 4 in., including frame.

Here is another subject in the popular Modelcraft series of Picture Marquetry Kits. The designs will form the basis of an interesting collection and provide excellent home decorations.

- No. 1 SET "King's Head" and "Red Lion."
- No. 2 SET "Cross Keys" and "White Hart."

Price of each set (including P.T.). 7/-, Postage and packing 6d. extra.

From all Model, Hobby and Handicraft shops or send S.A.E. for full details to:—

MODEL CRAFT LTD. 77(L) Grosvenor Road, London, S.W.1.

botanical specimens is to dry them slowly in the air and then to spray them with a solution of a suitable synthetic resin or of paraffin wax in ligroin (light petroleum ether). The spraying must be done in a vacuum so that the wax solution enters the pores of the plant tissue. This necessitates a rather complicated and expensive apparatus. For simple trials, however, we suggest that you use a thin solution of celluloid in a mixture of 2 parts of acetone and 1 part of amyl acetate, dissolving about 1 part of scrap celluloid in 10-15 parts of these mixed liquids. Immerse the dried plant parts wholly in the above solution, and then place the impregnated tissue in a draught of air to dry quickly. This is as far as you are likely to get without expensive equipment.

Electric Cable Sealing Compound

COULD you give me a formula for a sealing compound suitable for sealing the ends of electric cables against dampness? It must soften with the heat of the hands and have good adhesive properties, also be white in colour, if possible.—P. Campbell (Glasgow).

ONE of the best sealing materials for electric cables is a 50 : 50 mixture of hard and soft bitumens, the two grades being gently melted together. The proportions of the two bitumen grades can be varied to almost any extent. The product will not soften under very moderate heat. It is highly water-resistant, is cheap and is highly electrically insulative. In colour, it is black which, we suppose, will render it disadvantageous for your requirements. If you want a perfectly white sealing compound, melt together about equal proportions of beeswax, paraffin wax and pale resin powder. Then stir into the molten product sufficient zinc or titanium oxide to bring the material up to the required consistency when in the solidified state. This product will be of a creamy white colour, but for general durability and insulative effectiveness it will not be the equal of the previously-mentioned black bituminous product. Many bitumen refiners prepare a special "electric-toughing" compound especially for electric cable work. You should consult any bitumen refiner, asphaltting firm or builder's merchant in your district in order to obtain these materials.

Laying Terrazzo Floor

I PROPOSE laying a terrazzo floor in my kitchen; the present floor is concrete but somewhat uneven. Please give me details of the usual methods employed for laying and finishing, mixtures, thickness and colouring?—B. D. Ivory (Preston).

THE laying of a terrazzo floor is never easy. The details of the work depend upon the nature of the materials which are intended to be used. The real Italian terrazzo consists of a matrix of asphalt mastic in which coloured stones have been embedded, the whole then being smoothed off level.

It will be necessary for you to lay a thin bed of asphalt mastic (red, brown or black at your choice). Whilst the asphalt is still soft, suitable fragments should be scattered over the material and embedded therein either by means of a roller or with the flat side of a shovel. The maximum size of the fragments of coloured stone, etc., should be approximately three-quarters the thickness of the asphalt layer. When, but not before, the asphalt has become perfectly cold, the entire surface must be gone over with a flat stone, using water as a lubricant. The stone can be of any nature but it must be harder than the hardest of the stones used for the terrazzo work. With careful work, you will be able to grind the surface of the floor level, leaving a

sort of mosaic of the coloured stones embedded in the asphalt matrix. This constitutes the true terrazzo which, we think, you desire. There are other types of so-called terrazzo, in which cement composition and various other materials are used as the matrix and, in some instances, tiles are embedded therein. This type of work, however, is by no means the authentic terrazzo of the Italian tradition.

You should be able to get asphalt material locally from Northern Asphalt Co., Walton-le-Dale, Preston, or from British Asphalt and Bitumen, Ltd., The Docks, Preston.

The existing floor need not be levelled previous to the laying of the asphalt matrix.

Optical Copying Device

I HAVE seen an American advertisement for an inexpensive device which enables accurate drawings to be made from life. It appears to reflect the subject down on to the drawing-board, requiring the artist merely to trace the outline. According to the advertisement it can also enlarge or reduce. Can you please explain the optical principle?—G. J. Chalk (Torquay).

THE optical principle of the instrument is probably as shown in the diagram. The essential parts are a mirror placed at an angle of 45 deg. and a lens. If it is inexpensive, the instrument can permit of nothing more than an ordinary reading-glass type of lens, as shown in our sketch. Now such a reading glass of 4in. diameter and about 15in. focus

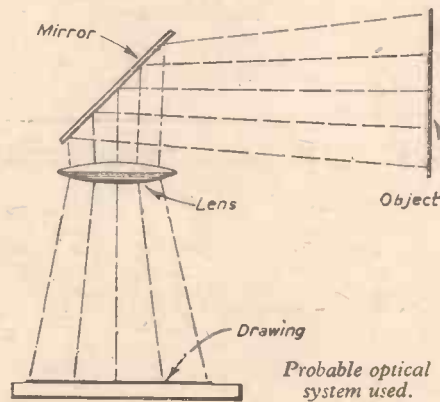

could be used but the image projected on to the drawing paper would not be equally and sharply defined all over the paper. Focusing is done by raising or lowering the lens and mirror and it would be found that when the image is sharp at the centre it is ill-defined at the edges, and vice versa. The fault is in the lens.

What is required to give good definition all over is either a photographic lens or a projection (lantern type) lens, working at a big aperture, such as f 3.5. However, it may be worth while to obtain a reading glass as indicated and experiment with it; some amount of satisfaction will be obtainable with it, and where the image is not dead sharp approximate outlines can be found and followed with the pencil.

A shield around the drawing-board will be found necessary in order to cut off extraneous light; that is to say, all light other than that coming through the lens from the mirror. If the lens is 4in. diameter the mirror should be rectangular and measure, say, 5in. wide by 6in. deep.

Zinc Chloride as a Wood Preservative

COULD you give me any information on the use of chromated zinc chloride as a wood preservative?—L. Carter (Romford).

IT is not possible to prepare a true "bi-chromated zinc chloride" because the addition of a chromatic salt would immediately give rise to zinc chromate or zinc bichromate which would be insoluble and which would not effectively penetrate the wood. Zinc chloride itself is an extremely soluble salt, and as such, it has been used a good deal for wood preservation, particularly against dry rot and other fungus attacks. The wood is usually immersed in a strong solution of zinc chloride (say, 1 part in 6 parts of water). The solution is used warm or hot and for as long a duration as circumstances permit.

The objection to the use of aqueous solutions for wood preservation is that they do not penetrate the wood adequately, that they may cause twisting, splitting and warping of the wood and that they tend to attract moisture to the wood afterwards. The modern method is to replace such solution by solutions of the various toxic metallic soaps such as copper, zinc and barium naphthenates, any of which materials may be obtained from Messrs. Thomas Tyrer and Co., Ltd., Stratford, London, E.15. About 5 parts of any of these compounds being dissolved in 95 parts of warm paraffin or white spirit and the resulting solution liberally brushed on to the timber several times. The objection to using copper naphthenate for this purpose is that it stains the wood a bright green, but zinc naphthenate solutions do not stain. Since these compounds are insoluble in water, they do not tend to become leached out of the wood on exposure to wet weather. They also help to waterproof the wood, whilst zinc chloride solutions have precisely the opposite effect.

Information Sought

Readers are invited to supply the required information to answer the following queries:

Mr. Gilfillan, of Belfast, writes: I am interested in the construction of a rain gauge. Can you explain to me how this can be made?

D. Trevithick asks: Could you please give me details for making a rope-making machine for model boats? I am making a model of a sailing ship of about 1700, and so require ropes of various thicknesses. What is the best material to use?

Mr. S. A. R., of Cambridge, writes as follows: Please supply me with details for grinding lawn-mower cylinders. This machine could be an already made job, but reasonable in price, or home made; these cutters would be from 10in. to 14in. I have a good workshop at hand.

The following is an extract from a letter from **F. Dunbobbin, of Warrington:** Please supply details of a permanent magnet electric motor, using two small Eclipse magnets for 4½ volts D.C. working. This is to drive a 3ft. model boat.

Mr. K. A. Maccuish, of Scotland, writes as follows: I wish to convert a Ford 10 engine for use in a 20ft. inshore fishing boat, using sea water as a coolant and T.V.O. for fuel.

Could you give me details of the necessary modifications and the address of a possible supplier of the required parts? What is the best kind of propeller and its size? Can I use the Ford gearbox, using first and reverse gears?

We have received the following request from **L. Edmonds, of Bushey, Herts:** Could you give me some ideas on the design and making of "Mobiles"?

From **Mr. J. S. Bowden, of Blackpool, comes the following:** Could you please supply the necessary information for constructing a small charcoal-stove, suitable for heating the cabin of a boat?

Mr. E. P. Jacobs, of Grimsby, writes: Please inform me how to make one of those writing tablets, wherein the writing is erased by withdrawing an interleaved strip or sheet.

A.C./D.C. MOTORS 24v. 2a., 6in. x 2 1/2 in. dia. spindle 1in. x 1/2 in. New 18/6.
Frequency Crystals 9,100 and 4,500 kc/s. New. 1in. space, 10/6; 4,860, 594, 561, 559, 505 kc/s, 6/6.

Powerful small Blower Motors, 24 v. A.C./D.C., 14/6. As used for the Hedge Trimmer.

Type 6C Oscilloscope Unit. With VCRI38 3 1/2 in. Tube, and conversion circuit for standard "Scope," 58/6.

Transformers, Input 200/240 v. Sec. tapped 3-4-5-6-8-9-10-12-15-18-20-24-30 volts at 2 amps., 21/6. 17-11-5 volts, at 5 amps., 22/6. 17-11-5 volts at 1 1/2 amps., 16/6. 6.3 volts, 2 1/2 amps., 8/6. 12 months' guarantee.

Selenium Rectifiers F.V. 12-6 volt, 1 A., 8/6. 3 A., 14/6. 4 A., 23/6. 6 A., 30/-, 24 v. 2 A., 30/-, 250 v. 100 mA. H.W., 9/-, 250 mA., 17/6, 60 mA., 6/6.

D.P.D.T. Relays. Operates at 200/300 volts D.C., 8/6. D.P. Make and Break, 8/6. Any combination or voltage can be supplied at varying prices.

0-5 amp. 2 1/2" Square M/c Ammeters, 11/-, Veeder Counters. P.O. Type, 24/50 v. D.C. 0,9999, 15/6.

M/c Microphones with matched transformer, 15/6.

6 volt Vibrator Packs. Self contained in steel box. Output 150 v. 30 mA., 22/6. Ideal for Battery Radios.

Rheostats, 12 v. 1 A., 2/6. 12 v. 5 A., 10/6
Latest Car Lights Relay Assembly "Flasher" Unit, 6 or 12 v., 17/6; or with 2 lamps and switch, 50/- STATE BATTERY CONNECTION TO CHASSIS.

4 ft. Fishing Rod Aerials, Set 3, 7/6. Base, 3/6.

TR.1196. Transmitter Section. NEW and complete—less valves—4.3-6.7 Mc/s. Easily converted, 15/-. Valves are EF50, TT11, EL32, set 25/-.

Carbon Twist Drill Sets of six, — to 1/2" or 3/8" to 1 1/8", 3/6 set.

All Carriage Paid in U.K.

THE RADIO & ELECTRICAL MART

253, Portobello Rd., London, W.11 Park 6026

THE HANDYMAN WILL TREASURE THIS 'THIRD HAND'



The Improved **MOLE** Self Grip **WRENCH** 7"-12/6 10"-15/-

This multi-purpose tool locks on to work with tremendous grip and stays there with hands off until the release lever is touched—how often have you wished for just that? Use it as super pliers, a vice, wrench, clamp and so on. The Mole Wrench is your "third hand"—sturdy, easy to handle—really something to treasure.

If any difficulty write to:—**M. MOLE & SON, BIRMINGHAM, 3.**

From **Ironmongers, Motor and Motor Cycle Accessory Dealers.**

This is a **H.S. Milling Cutter Bargain**. All 1" bore, 3"-3 1/2" dia., 1"-1 1/2" thick, including side and face cutters, plain and angle cutters. A most useful lot for any tool room, 6 ass. for 50/- The present maker's price of the cheapest cutter in this selection is 40s. You must get this lot, remember you get same on approval against cash.

2,000 Small H.S. Twist Drills, approx. 1/32"-3/32", 4/- doz. approx.; 1/16"-1/8" 7/6 per doz. approx.; 9/32"-15/32", six for 10/-.

All items brand new. £1 orders post paid. Prompt delivery. Inspection by appointment only. All items sent on approval against cheque or P.O. Refund without question if any item returned.

3,000 Circular Split Dies 1" dia. cutting 1/8", 5/16", 1/2", 7/16", 1" Whit. E.S.P. also brass thread, 26 thread all sizes and American N.F. 12/- per set of 5 sizes, 2 sets 22/6, 4 sets 42/6. Taps to suit 9/3 per set, either taper or second or plug. 1" die-stocks 5/- each; 3/16" to 1/2" tap wrenches 12/6 each.

1,000 Hand Reamers, 1", 5/16" and 1", 5/8 per set of three; 3/6 each.

1,000 High Speed Inserted Blades Expanding Reamers, 17/32" to 19/32" 14/-, 9/16" to 1" 18/-, 11/16" to 1" 17/6, 1" to 31/32" 18/6, 31/32" to 1" 22/6 each.

7,000 Pratt & Whitney, circular split dies, superior quality precision ground cutting edges, 13/16" dia., suitable for machine or hand use. Sizes: 2, 4, 5, 6 B.A., 8/6 per set.

5,000 Ball Races, 1/2" bore, 1" o.d., 1" thick, 4/- pair; 1/2" bore, 1" o.d., 7/32" thick, 4/- pair; 6 mm. bore, 19 mm. o.d., 6 mm. thick, 4/- pair; 9 mm. bore, 26 mm. o.d., 8 mm. thick, 4/- pair; 1" bore, 1 1/2" o.d., 7/32" thick, 5/- pair.

4/9 Assorted. Five lots 22/6. 2 Cutters 1/2" dia., 1/2" hole, 1" and 3/16" thick, worth 7/6 each. Set 3/32", 3/16" 7/32", 1" all in 40 thread, 13/16 Split Dies: 8 assorted Centre Nail Pin and Belt Punches, total value 12/6; one H.S. Tap or Reamer Fluting Cutter, 2 1/2" dia., 1" thick, 1/2" hole; one 1" H.S. Hand Reamer, worth 10/-. Every item a good bargain.

500 Sets Metal Figure Punches, nine punches 0 to 8, the six is used reverse for nine; size 5/64" 6/6 set, worth 15/-; ditto 1" size, 8/6.

2,000 Files, 4" to 6" flats, half-rounds, rounds, squares, warding assorted, cuts, good general lot, 10/6 doz.; three doz. 28/6.

800 Circular Split Dies, B.T.D. make 2 1/2" dia., 1" hole, 1" o.d., 1" Gas; worth 11/- each. Clear 7/6 each, new 2 1/2" die-stock to suit, worth 30/- each, clear 10/- each.

200 Boxes A to Z Steel Letter Stamps for marking metal, 5/64" size, 17/6 set; ditto 1" size, 22/6 set, worth treble this price.

2,000 Straight Shank End Mills, size 1", 5/32", 3/16", 7/32", 1/2", 5/16". List price 30/- set, handy bargains, 15/- set, also 1", 5/16", 1/2" ditto, 12/6 set, all in makers' wrappings.

500 H.S. 90° Countersinks, body 1" dia., teeth cut to point. An essential tool for any workshop using c/s screws. Gift 5/- each.

1,000 Bevelled Wood Chisels, handed, 1", 5/16", 1/2", 3/4", 1", 1 1/4", 1 1/2", 1 3/4", 2", 2 1/2", 3", 4", 5", 6", 8", 10", 12", 14", 16", 18", 20", 24", 30", 36", 42", 48", 54", 60", 72", 84", 96", 108", 120", 144", 168", 192", 216", 240", 270", 300", 360", 420", 480", 540", 600", 720", 840", 960", 1080", 1200", 1440", 1680", 1920", 2160", 2400", 2700", 3000", 3600", 4200", 4800", 5400", 6000", 7200", 8400", 9600", 10800", 12000, Actual value 32/6. Gift 15/- set, 15/-.

3,000 High Speed Routing Cutters, straight shank, two lip, as used for cutting slots in wood, sizes 1", 1 1/4" dia., clear 4/- each.

1,000 Toolmakers' Needle Files, good assortment of shapes and cuts, worth 1/9 to 2/6 each, 12/6 doz.

200 Ace Dial Gauges, 2 1/2" face, reads to 0.001", plus and minus, very useful instruments worth 60/-, gift 45/-.

10,000 High Speed End Mills Straight Shank, 3/32" to 3/16" dia., some with teeth cutting both end but not standard sizes, clear 5 assorted, 10/-.

100 doz. 6" Three square Saw Files, 10/6 per dozen.

1,000 "Leytool" Ratchet Spanners, 3/16", 1/2", 5/16", 1", 7/16", 1" Whit. Makers' price 70/- per set. Very useful bargain, 35/- per set.

1,000 Semi High Speed Centre Drills, Slcombe brand, 5/16" body dia., 3/32" point, 1/8 each, 16/6 per doz.

1,500 H.S. Morse Taper Shank Twist Drills. Brand new, Fifth Speed-cut, Balfour Capital, etc. All best quality drills, No. 1 and 2 Morse Taper shanks, sizes from approx. 1/8" dia. to approx. 1" dia. Five assorted 1/2", actual value £3. One dozen assorted 42/6.

20,000 Small High Speed Milling Cutters, various shapes and styles. We want to clear these quickly, 12 assorted, 15/-.

800 Small Rotary Files, 3/32" shanks, various type heads, another clearance line, 4/9 per doz.

250 Three-Jaw Drill Chucks, No. 1 Morse taper shank, 0-to-1" capacity, 5/- each.

J. BURKE, 192 Baslow Road, Totley, Sheffield

Inspection Only at Rear 36, Fitzwilliam Street, Sheffield

TAKE UP PELMANISM

For Courage and Clear-Thinking

The Grasshopper Mind
YOU know the man with the 'Grasshopper Mind' as well as you know yourself. His mind nibbles at everything and masters nothing. At home in the evening he tunes in the radio—tires of it—then glances through a magazine—can't get interested. Finally, unable to concentrate on anything, he either goes to the pictures or falls asleep in his chair. At his work he always takes up the easiest job first, puts it down when it gets hard and starts something else. Jumps from one thing to another all the time.

Reduced fees for members of Her Majesty's Forces. (Apply for Services Form.)

There are thousands of these people with 'Grasshopper Minds' in the world. In fact, they are the very people who do the world's most tiresome tasks—and get but a pittance for their work. They do the world's clerical work, and the routine drudgery. Day after day, year after year—endlessly—they hang on to the jobs that are smallest salaried, longest houred, least interesting, and poorest funded!

What is Holding You Back?

If you have a 'Grasshopper Mind' you know that this is true. And you know why it is true. Even the blazing sun can't burn a hole in a piece of tissue paper unless its rays are focused and concentrated on one spot. A mind that balks at sticking to one thing for more than a few minutes surely cannot be depended upon to get you anywhere in your years of life!

What Can You Do About It?

Take up Pelmanism now! A course of Pelmanism brings out the mind's latent powers and develops them to the highest point of efficiency. It banishes such weaknesses and defects as Mind Wandering, Inferiority and Indecision, which interfere with the effective working powers of the mind, and in their place develops strong, positive, vital qualities, such as Optimism, Concentration and Reliability, all qualities of the utmost value in any walk of life.

Remember—Everything you do is preceded by your attitude of mind.

The Pelman Course is simple and interesting, and takes up very little time; you can enrol on the most convenient terms. The Course is fully described in "The Science of Success," which will be sent you, gratis and post free, on application to:

PELMAN INSTITUTE, 130, Norfolk Mansions, Wigmore Street, London, W.1.

Established over 50 years.

POST THIS FREE COUPON TO-DAY

To The Pelman Institute, 130, Norfolk Mansions, Wigmore Street, London, W.1.

"The Science of Success," please.

Name

Address

PELMAN (OVERSEAS) INSTITUTES, DELHI: 10, Allpore Road. MELBOURNE: 386, Flinders Lane. DURBAN: Natal Bank Chambers (P.O. Box 1489). PARIS: 176, Boulevard Haussmann. AMSTERDAM: Prinsengracht 1021.

WATSON'S SPECIAL OFFERS

LYON ALCO

12/18v. 360w. £22-10-0

Carr. 12/6

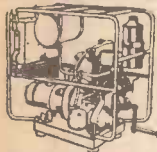

These are very fine Generating Sets, self contained in steel frame and complete with switch panel UNWID ready for service. **MINE DETECTORS**.—A fine article with hundreds of uses for detecting concealed metal objects. £4.10.0. Carr. 10/-.

IMMERSION HEATERS.—Each with control switching, giving 250 w., 500 w. and 1,000 w. as required. Suitable for 220-230 v. Well made and ideal for a variety of heating jobs. 35/- each. Carr. 3/-.

EX R.A.F. TOOL BOXES.—Size 14in. x 9in. x 8in. Dometalled and metal bound. 8/6 each. Carr. 2/6. Larger size 20in. x 12in. x 11in. Price 13/6. Carr. 3/6.

FLEXIBLE DRIVES.—As used on A.M. Tachometers, Heavy duty flexible metal sheath with brass connecting nuts.

Rectangular hardened steel driving ends. 1in. long x 9/64in. square. Three lengths approx. 1ft., 3/6; 2ft., 6/6; 7ft., 15/-.

BARGAIN PRICE OF AIRCRAFT INSTRUMENTS.—Containing one Altimeter, Air Speed Indicator, Rate of Climb, and three assorted instruments, six in all. Amazing value at 29/6. Also a LARGER PACKAGE containing in addition to the above One Turn and Bank Indicator, Boost Gauge, Repeater Compass. Nine in all. 49/6.

LENS UNIT.—Consisting of two 1/2in. lenses in 2in. brass focusing mount with adjustment 2in. overall. 14/6. Post 1/-.

CO-AXIAL CABLE.—Impedance 50 ohms. 1/- yd. Plus carriage.

RELAYS.—12 volt in bakelite case, 4in. x 1 1/2in. x 1 1/2in. 6/6. Post 6d.

DRAIN TAPS in brass, 1/2in. gas thread. 1/9. Post 6d.

DYNAMOS.—Shunt wound, foot mounted, ball bearing, 14/32 v. 9 amps. 288 w. 67/6. Carr. 3/6.

CLOCKWORK MOTORS.—Exceptionally well made, heavy brass double spring motors taken from gun predictors, 37/6. Post 2/-.

Hundreds of other bargains available. Send Stamp for List. **EASTERN MOTORS, ALDEBURGH, SUFFOLK.** Phone: 15.

Telephone: MUSEUM 9594

H. FRANKS

58-60, New Oxford St., London, W.C.1

One Minute from
Tottenham Court Rd. Station

ELCO SYNCHRONOUS CLOCK MOVEMENTS, 200/250 v. A.C. 50 cys. with spindles for hours, minutes and seconds, in bakelite dust cover 3in. diam. 2in. deep, with flex lead, one hole fixing, up to 1in. panel. Inclusive set of 3 hands, suitable for 10/12in. dial. 27/6 each, post paid.

ELECTRO-MAGNETIC COUNTERS, P.O. type. Four digit, 6 volts, 3 ohm coil, 10/- each. Ditto 24 volts, 400 ohm coil, 12/6 each.

HIGH QUALITY EX-AIR VACUUM PUMPS, size 6in. x 4in. x 4in. approx. Flange mounting, weight 5lb., spline shaft 2in. long 1in. diameter; needs a 1 h.p. motor to drive same. Price 37/6 each.

SELF-PRIMING IMMERSION PUMPS (Electric) Ex-Air Ministry. Fitted 24 v. D.C. motor, will work on 24 v. A.C., overall length 20/24in., delivers approx. 150 g.p.h., ideal for use in caravans, boats, laboratories, etc. 37/6 each.

ALTIMETERS, Ref. 6A/1537. Ideal for conversion to barometers, etc. 7/6 each.

SENSITIVE TYPE ALTIMETERS by Kelsman, Ref. M. XIV A, reads to 35,000ft. by means of 3 pointers, 3in. dial and adjusting knob, as recommended in P.M., September, 1954. Ideal for conversion to barometer. 27/6 each.

SYNCHRONOUS CLOCK UNITS. Self-starting 200/250 v. A.C. 50 cycle, fitted Sangamo motors, consumption 24 watts, size 2 1/2in. diam., 2in. deep, geared 1 rev. 60 mins., friction reset. Ideal movements for electric clocks. With gear train and 6in. hands. Price 22/6 each, post paid.

AIR TEMPERATURE GAUGES, Ref. No. 6A/510, fitted Mercury in Steel Capillary Tube, Transmuting type. Reading -30/0/80-Centigrade. Suitable for greenhouses, etc. 18/6.

TUFNOL PULLEYS. Fitted ball-races, external diam. 2 1/2in., internal diam. 1 1/2in. 2/9 each, 30/- per doz.

DITTO, 4 1/2in. external, 1 1/2in. internal, 5/- each, 55/- per doz. 2,000 of both types available.

CLOCKWORK MOVEMENTS fitted "VENNER" Escapement, run 10 hours one full wind, final speed 1 rev. 75 secs. Price 9/- each, post paid.

VARIABLE RHEOSTATS. Graduated 1 amp. to 2 amps., 45 ohms. Ideal for chargers, voltage control, etc. Ref. 5C/728, fitted in bakelite case 4in. square, 1 1/2in. deep, 12/6 each.

"KLAXON" 1/40 h.p. permanent capacitor induction motors, 220/240 v. A.C. 50 cycles, 2,700 r.p.m. continuous rating. Reversible, diam. 3 1/2in. length 5 1/2in. plus spindle 1 1/2in. long, 5/16in. diam., £3.5.0 each.

WORM GEAR UNITS, fitted 5 start steel worm. Fitted in ball-races, on pedestal, with 51 tooth Bronze wheel (loose) to mesh. Ratio 10.2/1 reduction, 11/- each.

SPERRY 1/70th h.p. 115 volt A.C. 50/60 cycle motor constant speed 3,000 r.p.m. governor controlled, continuous rating. Can be used with series resistance or transformer off 200/250 v. mains, ideal for line projectors, light drilling, etc. Radio suppressor unit included, £2.0.0 each.

INFINITELY VARIABLE SPEED GEAR BOXES fitted 1in. diam. shafts, mounted in ball-races, adjustable torque, reversible, overall size 5in. x 5in. x 4in. approx. Precision made, 47/6 each.

DITTO. Smaller type, overall size 3in. x 3in. x 3in. approx., 40/- each.

PRECISION DIFFERENTIAL GEAR UNITS, fitted 1in. diam. spindle, 48 D.P. Gears, size 2in. diam. 1in. deep, 8/- each.

CLOCKWORK-DRIVEN TIMERS, variable, 5 to 30 mins. Fitted 15 amp. A.C. contacts. Totally enclosed crackle finish, 17/6 each.

SANGAMO MOTOR UNITS, MODEL 7, final speed 1 rev. per 7 days, 200/250 v. A.C. 50 cycles, 30/- each.

Ex-Air Min. GEAR PUMPS. Type RFP/1, made by Rolls-Royce, size approx. 6 x 5 1/2 x 5in. Price 30/- each, post paid.

4 to 1 RATIO GEAR BOX UNITS, ex-Wind-screen Wiper Units, mounted in ball-races, overall size 5 x 3 x 3in., 14/6 each.

12/24 VOLTS HOOVER BLOWER MOTORS, Ref. 10KB/115, as recommended for car heaters in a recent issue. Price 27/6 each.

FULL MAILING LIST PRICE 6D.

RUSTED FITTINGS?

Free them quickly with

Shell Easing Oil

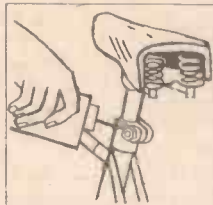

Shell Easing Oil comes in a handy 8 oz. tin with special power spout — very good value at 2/6.

Here's the way to free those rusted fittings! Free them quickly, too. Shell Easing Oil is sure and swift, penetrates deeply to loosen and free.

From nuts and bolts to taps and pipe joints, from bicycle frames to window catches, Shell Easing Oil is the answer to your rusted parts problem.

SHELL EASING OIL is very handy in the house—and very good value at 2/6! Buy some to-day—good ironmongers stock Shell Easing Oil.



BE IN THE LEAD ...

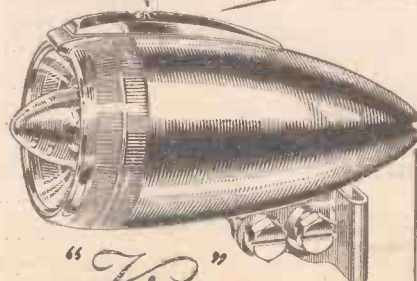
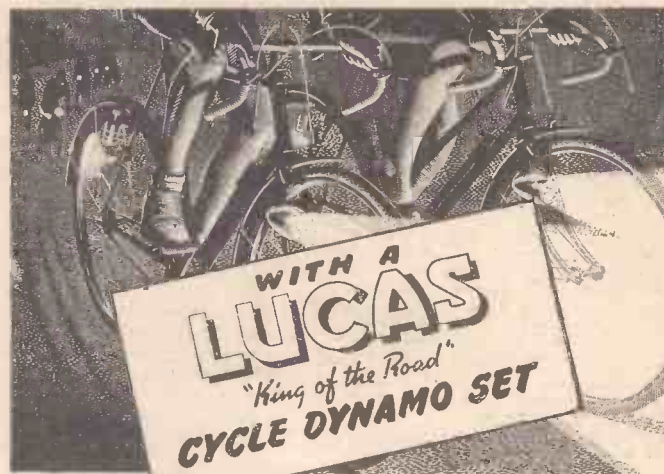

Weights only 6 1/2 ozs., has a single bulb light unit which projects an intense spot beam yet gives ample local light. 32/6 complete.

"King"
SPORTS

JOSEPH LUCAS (CYCLE ACCESSORIES) LTD · CHESTER ST · BIRMINGHAM 6.

GALPIN'S

ELECTRICAL STORES

408, HIGH STREET, LEWISHAM, S.E.13

Tel.: Lee Green 0309. N.r. Lewisham Hospital.

TERMS: CASH WITH ORDER. NO C.O.D.

All goods sent on 7 days' approval against cash.

EARLY CLOSING DAY THURSDAY

HEAVY DUTY SPOT WELDER TRANSFORMERS, input 200/250 volts. OUTPUT a combination of 2, 4, 6, 8, 10, 12 volts at 120/150 amps. New £6/15/- each, carriage 6/-.

LIGHT ARC WELDING TRANSFORMERS, 200/250 volts Input, Output 40/60 volts, 30/40 amps, £7/5/- each.

MEDIUM SPOT WELDING TRANSFORMERS, input 200/250 volts, OUTPUT a combination of 2, 4, 6, 8, 10, 12 volts at 50/70 amps. New £5/2/6, C/paid.

HEAVY DUTY L.T. OUTPUT TRANSFORMERS, 200/250 volts Input. Output a combination of 6, 12, 18 and 24 volts at 30 amps. £4/2/6 each. C/paid.

Another Input as above, Output 0, 6, 12, 18, 24 volts at 12 amps. 55/- each, post 2/-. Another Input as above, Output 0, 6, 12, 18, 24 volts, 6/8 amps, 46/6 each.

HEAVY DUTY L.T. TRANSFORMERS suitable for rectifiers, soil heating, etc. Input 200/250 volts. Output a combination of 6, 12, 18, 24, 30, 36 volts at 15 amps. 67/6 each, post 2/6. Another Input and Output as above but at 6 amps. 47/6; post 2/-. Another input and output as above but at 4 amps., 36/6 each.

CONVERTORS, 400 watts output, 24 volts D.C. input, 50 volts 50 cycles 1 phase output. Complete with step-up transformer from 50 volts to 230 volts at 400 watts, £12/10/- each C/F. Ditto 200 watts. £9/10/- each C/F., fully guaranteed.

ROTARY CONVERTORS, 230 volts D.C. input, 230 volts A.C. output, 50 cycles 1 phase at 250 watts. £15 each C/F.

EX-RADAR MAINS TRANSFORMERS. Input 230 volts. Output 4 or 5 Kilo-volts at 30 min., also 3 L.T. windings 4 v. 2 a., 6.3 v. 2 a., 2 v. 2 a., these transformers are capable of a larger output than stated and are immersed in oil. £3/15/- each, carriage 5/-.

MAINS TRANSFORMERS (NEW), input 200/250 volts in steps of 10 volts, output 350/0/350 volts, 180 m/amps., 4 volts 4 amps., 5 volts 3 amps., 6.3 volts 4 amps., 45/- each, post 1/6; another 350/0/350 volts 180 m/amps., 6.3 volts 8 amps., 0/4/5 volts 4 amps., 45/- each, post 1/6; another 500/0/500 volts 150 amps., 4 volts 4 amps., C.T., 6.3 volts 4 amps., C.T., 5 volts 3 amps., 47/6 each, post 1/6; another 425, 0/425 volts 160 m/amps., 6.3 volts 4 amps., C.T., twice 5 volts 3 amps., 47/6 each, post 1/6.

MAINS TRANSFORMERS, 200-250 volts input, output 400/0/400 volts, 280 m/amps., 6.3 v. 8 a., 2 v. 3 a., 5 v. 3 a., 4 v. 2 a., 4 v. 2 a., the last two heaters insulated at 8,000 volts, 85/- each; another 200/230 volts input, output tapped 0, 9, 18 volts at 4 amps., 25/- each, post 1/-.

MAINS TRANSFORMERS, 200/250 volts input, 300/0/300 volts 150 m/amps., 6.3 v. 4 a., 4 v. 2 amps. output. Makers Rich & Bundy. 32/6 each, C/paid.

EX-U.S.A. ROTARY CONVERTORS, 12 volts D.C. input, outputs 500 volts 50 mA. 275 v. 100 mA. Complete with smoothing, 22/6 each, carriage 2/6. As new.

EX-NAVAL ROTARY CONVERTORS, 110 v. D.C. input 230 volts A.C. 50 cys. 1 ph. 250 watts, output. Weight approx. 100 lbs. £12/10/-, C/F.

ELECTRIC LIGHT CHECK METERS, useful for sub-lighting, garages, etc., all for 200/250 volts A.C. mains, 5 amp. load, 19/- each; 10 amps., 22/6; 20 amps., 27/-; 25 amps., 32/6.

METERS. Moving coil, 0 to 14 amps., 18/6 each. Ditto, Moving Iron, suitable for A.C. 0 to 30 amps., 25/- each. Another moving coil, 100 to 250 amps., D.C. 35/- each, all 4in. scale.

1,000 WATT AUTO WOUND VOLT-AGE CHANGER TRANSFORMER tapped 0/110/200/230/250 volts. £5/15/- each, carriage 4/6. 1,500 watt ditto, £7/15/-, carriage 7/6. 350 watt 55/-, 500 watt 75/-, 200 watt 45/-.

PRE-PAYMENT 1/- ELECTRIC LIGHT SLOT METERS, 5/H, reconditioned, variable tariff. 10 amp. load, 200/250 volts A.C. 55/- each.

Clients in Eire, please allow at least double the carriage stated to allow for customs clearance charges.



VOL. XXIII

DECEMBER, 1954

No. 391

All letters should be addressed to the Editor, "THE CYCLIST," George Newnes, Ltd., Tower House, Southampton Street, Strand, London, W.C.2.

Phone: Temple Bar 4363

Telegrams: Newnes, Rand, London

COMMENTS OF THE MONTH

By F. J. C.

The Cycle Show

BY the time this issue appears the Cycle Show will be over, and we can now consider what it revealed. Nothing very startling. Indeed, if there has been any change in bicycle design during the past 10 years, it has been towards flamboyant and somewhat garish colour schemes. The black finish with a gold line is a thing of the past, except, perhaps, for utility cyclists. It is open to question whether these highly-coloured machines add to the dignity of the sport or to the rider. We would have preferred to have seen greater attention given, not to eye-appeal, but to improvement in braking systems, lighting systems, the elimination of unsightly cables, saddles which are really seats instead of perches, the complete abolition of the flap-down oiler and the introduction of oil-gun lubrication, improved head bearing design, the introduction of sprung frames for touring machines (instead of relying upon the tyre to provide the cushioning effect), every manufacturer to state the weight of the machines he is selling so that the purchaser can ascertain whether they are really lightweight, improved chromium plating (plating generally is poor, sometimes "flashed" straight on to the metal instead of a copper-nickel chrome finish), greater attention to weatherproofing and improved transmission. The exposed chain, especially when it is used in conjunction with a Derailleur gear, should surely not figure in a 1954 specification. In our view, the proper place for a gear is either in the bottom bracket or in the hub. All chains should be enclosed until such time as manufacturers have learned

the advantages of the shaft drive, with its minimum of moving parts and the total enclosure of the gearing. One or two motor-cycle manufacturers have developed a shaft drive. It is a matter of surprise that the chain still persists in spite of its obvious disadvantages. Its efficiency when it is new is, of course, high, but that efficiency soon drops off by the time that grit has been converted into a grinding paste by mixing with the oil. This not only laps the pins of the chain, but also the chain wheel and sprocket. There is plenty of room still for improvement of bicycle design. Someone should surely produce a lighting set which incorporates a chargeable storage battery.

There were 21 exhibitors of cycles and 88 exhibitors of accessories and components. The exhibitors were mainly the large companies whose products now include those of many other famous trade names.

The British bicycle is still the best in the world and Great Britain the largest manufacturing and exporting country. Perhaps that is the reason why the export and home demand for British bicycles is running ahead of output and causing leading manufacturers to expand to meet current and future requirements. A fair percentage of the industry also manufactures motor cycles, and world sales of these have achieved a bigger percentage increase than cycles. Exports of motor cycles in the first nine months of this year totalled £6,400,000, compared with £5,700,000 in the same period last year, while cycle exports were up from £12,800,000 to £13,600,000. The

home market has become livelier for cycles since the introduction of easier hire-purchase terms, and contributory factors have been rising public transport costs and inability of undertakings to deal with rush-hour travel. This has resulted in growing sales of power units for cycles, with its concomitant demand for bicycles. The sale of lightweight motorised cycles continues to increase. Indeed, the Cycle Show revealed the growing interest in motorised bicycles, which the C.T.C.ites superciliously referred to as "buzz bikes" or "bicycle-assisted motors." Already, owners of motor-assisted bicycles have their own national body watching their interests. The C.T.C. made a grave mistake in sneering at the newcomer, and making ridiculous statements that the law of the land did not permit the C.T.C. to take an interest in motorised bicycles. The law of the land does nothing of the sort. They did not accept our challenge to name that law. The fact is that the C.T.C. did not want to take an interest in motorised bicycles. They must be gazing with envious eyes at the market which they have turned aside, for road vehicle registrations in the first six months of this year show that nearly 26,000 power units were bought, compared with less than 20,000 in the same period of last year, and there is now a total of 207,000 on the road, and this growth has been achieved in the short space of five years. There is a swing from attachable units to factory-designed motorised cycles with strengthened frames and brakes. A newcomer in the field is the firm of Philips, a subsidiary of Tube Investments, Ltd., and another is B.S.A., who now supply a special frame with sprung front forks for the "Winged Wheel" unit. The makers of the "Cyclemaster" have commenced production of a complete motorised bicycle—the "Cyclemate." Hitherto they have only supplied a rear wheel unit.

Two exhibitors exhibited all-British scooters for which there is likely to be a fair demand. Those at present seen on the roads of Great Britain are of Continental design and made under licence. The export and home market potential for powered cycles and scooters is undoubtedly brilliant. Those members of the C.T.C. who have turned to motorised bicycles should consider joining the National body concerned with motorised bicycles and whose address may be had upon request. They may consider it embarrassing to remain members of a body which has made such offensive remarks concerning their mounts.

We repeat our suggestion that at next year's show there should be a competition for models of pedal bicycles. This year the Auto-Cycle Union exhibited models submitted in connection with their Model Motor Cycle Competition, in which there were three classes—Pioneer, Vintage and Modern. We were awarded the first prize in the Pioneer Class, and photographs of the winning machines are reproduced on page 14 of this issue. We have refunded the cash part of the prize, which included an engraved plaque, to the Auto-Cycle Union Benevolent Fund.

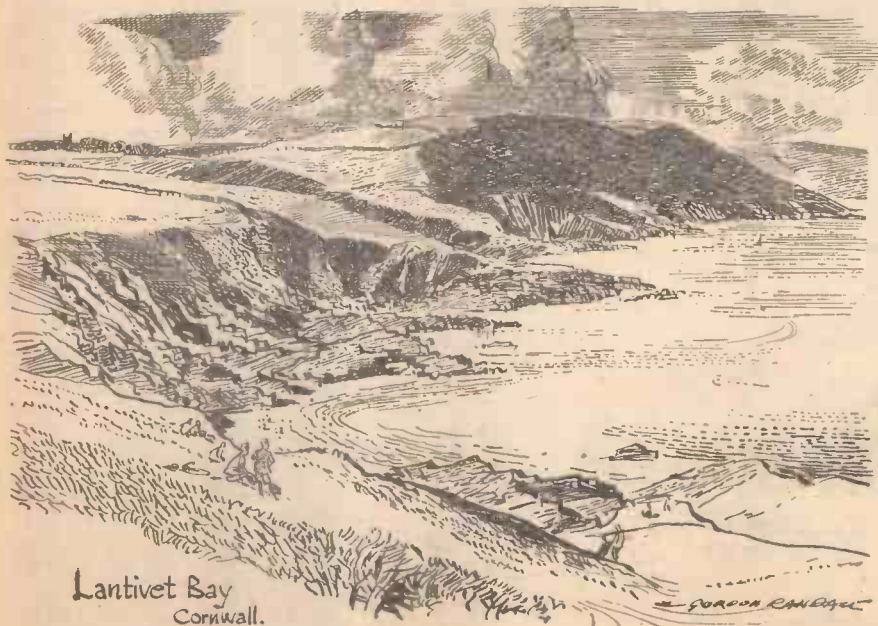

Lantivet Bay
Cornwall.

A lovely bay lying east of Looe. On the horizon can be seen the tower of the fine 15cent. church of Lansallos.

AROUND THE WHEELWORLD

The Late George Ernest Osmond

GEORGE ERNEST OSMOND, who died in his home at High Wycombe recently in his 84th year, was a man of singular ingenuity, versatility and charm. In the 90's, when he was a young man and cycling was the most popular pastime and sport of the day, he built a bicycle of his own and had distinguished success in racing. He was a brother of the famous Fred Osmond, but his achievements were overshadowed by those of his brother. Indeed, it is possible that Fred inspired him to enter the field of cycling. Much was expected of him, but he was not of the same calibre. His first notable race was that for the Brixton Cup—10 miles—in which he clipped all records from three to six miles, but failed to hold his own to the end against the South African flier, L. S. Meinjies. On several occasions G. E. Osmond shone as a record breaker and was particularly successful in his tandem rides with R. G. Merry and later with J. W. Stocks. He was a great friend of the Wright Bros., and spent his later years in mechanical inventions, taking out over 80 patents.

New Headquarters for the Union

IT has been announced that the British Cycle and Motor Cycle Manufacturers' and Traders' Union, Ltd., has purchased a building site adjacent to Coventry Station, upon which it is intended to erect a new and modern headquarters. Coventry had been the traditional home of the Union for more than 40 years and although to-day there are few cycle and motor cycle manufacturers located in the city, it is still regarded as the birth-place of the industry and the most appropriate central location for the industry's trade organisation. Within a few hundred yards of both the industry's present and future headquarters is a statue of James Starley, one of the pioneers and founders of the industry, inventor of the differential (first applied to a tricycle). England is the world's largest producer and exporter of bicycles and motor cycles.

By ICARUS

Eileen's Marvellous Record

EILEEN SHERIDAN now holds all of the W.R.R.A. professional records—there are 21 on the books. Recently she broke the shortest record recognised by the W.R.R.A., namely, the 25 miles out and home ride. Her time was 1 h. 3 m. 58 s. This is not the best time over the distance for a woman, although it is 2 m. 15 s. faster than the professional record for the same distance, which was made by Marguerite Wilson.

In thus holding all of the records, she has created a new record for herself in that no man has ever held all of the R.R.A. records. Indeed, she has beaten the record of Marguerite Wilson, who held 16 of the W.R.R.A. records. What will Eileen do now? Seek fresh lands to conquer, or should the W.R.R.A. create a new series of records?

Incidentally, the W.R.R.A. recently celebrated the 20th anniversary of its foundation. It is a thousand pities that the R.R.A. did not some years ago recognise women record breakers. Their long experience would have saved the W.R.R.A. from many of its teething troubles which were due entirely to lack of experience and in some cases to outright incompetence. It really needed men to organise the W.R.R.A.

An Overall Body?

AT the General Council Meeting of the N.C.U., held in October, it was agreed that proposals from other bodies relating to the formation of an overall body would be considered. The B.L.R.C. considered this point and forwarded the following proposals. This overall body is, of course, intended to assume control over all branches of the sport. Here are the B.L.R.C. conclusions:

1. The association should issue all licences.
2. There shall be three categories of licences—Amateur, Independent and Professional.
3. All clubs would affiliate direct to the association.
4. U.C.I. recognition shall be transferred to the new body as at the date of its formation.
5. Each body would contribute £500 to the association.
6. The association would be formed by not later than 1st January, 1955.
7. Licences would be issued from 1st January, 1955.
8. All existing bodies shall cease to exist as from that date.

As a matter of fact, the original proposal, much on the same lines, was submitted to the joint committee on the 7th February, 1944, before the U.C.I. decision was made known.

In a press statement the B.L.R.C. says that: "it would appear that following M. Joinard's letter to Mr. Anderson (N.C.U. president) of 17th March, 1953, the N.C.U. felt it imperative to secure an agreement with the B.L.R.C. as it was quite evident that there was a very good chance of U.C.I. recognition being transferred to the League in 1954."

Having secured this agreement the N.C.U. did everything in its power to ensure that the B.L.R.C. recognition was withdrawn at the 1954 congress. This, in fact, was the case and the N.C.U. have, since that date, used every pretext and excuse for not implementing the legal and binding agreement which they

(Continued on page 17)



Mr. F. J. Camm's 1/8th scale model of the 1895 Werner motor cycle, which secured 1st prize (Pioneer Class) in the Auto-cycle Union's Model Competition. The wheels are correctly spoked with screwed nipples, and every part is faithfully to scale. It was on show at the recent Cycle and Motor Cycle Exhibition. For full results, see next page.

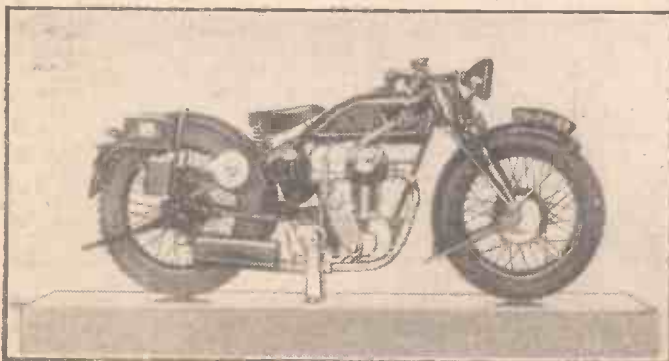

Mr. E. J. Graves' model of the 1930 K.S.S. Velocette—winner of 1st prize in the Vintage Class.

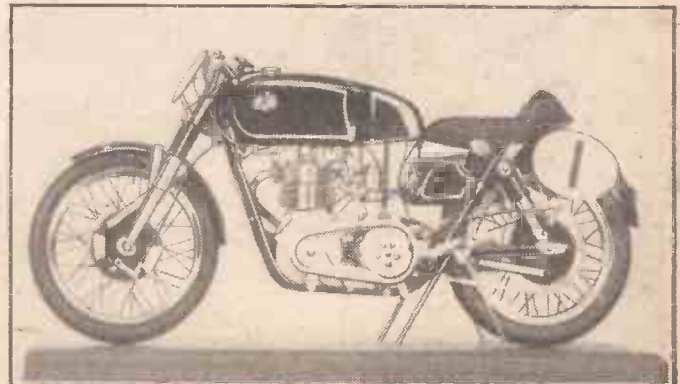

Mr. C. A. N. Rose's model of the A.J.S. 7R, winner of the 1st prize in the Modern Class.

BLACK & DECKER ELECTRIC TOOLS on EASY TERMS

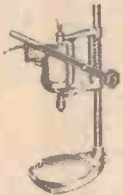

Build up your home workshop stage by stage on easy terms. The 1/2 in. drill shown drills, polishes, sands and grinds and can be used with the vertical stand and lathe, besides other attachments. Write for free full catalogue and easy terms schedule.

As Illustrated	Cash Price	8 Month Deposit	or 12 Month Deposit
1/2 in. Drill ...	£5.10.0	14/8	14/8
1/2 in. Stand ...	£3.7.6	8/3	8/3
Not Illustrated			
1/2 in. Drill ...	£12.7.6	30/3	30/3
1/2 in. Stand ...	£5.10.0	13/6	13/6
Craftsman's Lathe ...	£5.5.0	12/10	12/10
5in. Sander/Polisher ...	£8.7.6	20/6	20/6
5in. Sander/Polisher Kit ...	£9.17.8	24/2	24/2
1/2 in. Drill Kit ...	£11.17.8	29/1	29/1
6in. H.D. Saw ...	£17.5.0	42/2	42/2
Disc Sanding Table Att. ...	£1.12.6	3/11	3/11

When ordering please send Cash Price or Deposit and state Mains Voltage. All items are post free.

THE "I & G" UNIVERSAL SAW

Fits any electric hand drill. Will Jig saw, Cross cut, Rip Saw, Hack saw, etc. Complete with attachments and two extra saw blades. Send for leaflet.

Cash Price
49/6

(Postage & Packing 1/3)
or EASY TERMS

If purchased with any Black & Decker equipment, 10/- deposit and eight monthly payments of 5/9.



BURGESS PAINT SPRAYER

For spraying Paint, Varnish, Lacquer, Light Oils, Insecticides, etc. As easy to handle as a brush. Just plug in and spray. A.C. mains only. State Voltage.



YOURS FOR 9/2 DEPOSIT!!

Cash Price
75/-

Post Free or 9/2 Deposit and 8 monthly payments of 9/2. Send for Leaflet.

AUTOMATIC MINIATURE BLOWLAMP

No pumping—it's self-pressurising. No working parts to go wrong. Burns methylated spirit. Weighs only 7 ounces and is 5 1/2 in. in height. All parts are interchangeable and spares obtainable. Attains temperature of 2,000 deg. F. Ideal for SOFT SOLDERING, SILVER SOLDERING, PAINT STRIPPING, GLASS BENDING and DRAWING. This pocket size blowlamp is a valuable addition to every tool kit. Made of solid brass without soldered joints. SEND FOR ILLUSTRATED LEAFLET.

12/6 Post 9d.

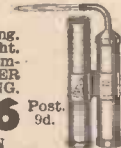

THE MAIL ORDER HOUSE FOR PROMPT ATTENTION
We would like to wish our customers a Happy Xmas & a Prosperous New Year.
KINGSWOOD SUPPLIES (Dept. PM.4) 2, 3 & 4, SALE PLACE, LONDON, W.2. Telephone PAD 8189

IT IS EASY TO MAKE THESE LUXURIOUS ELECTRIC BLANKETS

★ NEW EXTENDED RANGE

DRAWINGS AND INSTRUCTIONS: for Single Heat Blanket, 60in. x 30in. Price, 1/6. Post Free.

Or with 27 yds. Heater Cable. Price, 20/- Post Free.

DRAWINGS AND INSTRUCTIONS:

for Three Heat Blanket, 60in. x 30in. Price, 2/- Post Free.

Or with 2 x 27yds. Heater Cable, 2 Temp. set thermostats, 1 3-Heat Switch, 18in. Triple, 23/36 Flex. Price, 45/- Post Free.

DRAWINGS AND INSTRUCTIONS: for Single Heat Blanket, 60in. x 50in. Price, 1/6. Post Free.

Or with 30 yds. of Heater Cable. Price, 30/- Post Free.

DRAWINGS AND INSTRUCTIONS: for Three Heat Blanket. 60in. x 50in. Price, 2/- Post Free.

Or with 2 x 30 yds. Heater Cable. 2 Temp. set thermostats, 1 3-Heat switch, 18in. Triple Flex and 3 yds. twin 23/36 Flex. Price, 55/- Post Free.

DRAWINGS AND INSTRUCTIONS: for Single Heat Heating Pad. 16in. x 12in. Price, 1/6. Post Free.

Or with 8 yds. of Heater Cable, 3 yds. twin 23/36 Flex, and ON/OFF switch. Price, 12/6. Post Free.

DRAWINGS AND INSTRUCTIONS: for Three Heat Heating Pad. 16in. x 12in. Price, 2/- Post Free.

Or with 2 x 8 yds. Heater Cable, 3 yds. twin 23/36 Flex, 18in. triple 23/36 flexible and 1 3-Heat switch. 2 Temp. set thermostats. Price: 17/6. Post free.

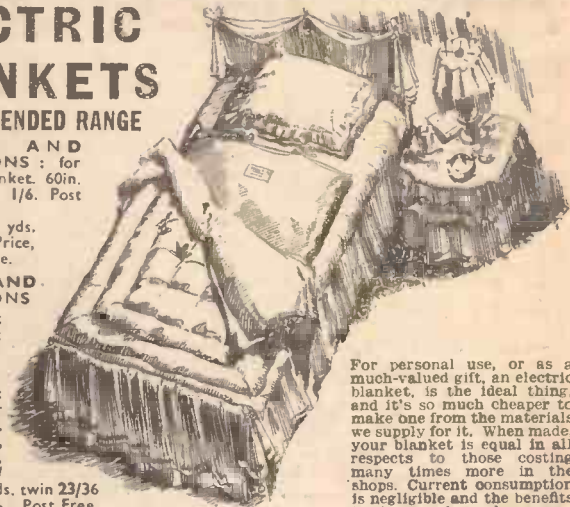

For personal use, or as a much-valued gift, an electric blanket, is the ideal thing, and it's so much cheaper to make one from the materials we supply for it. When made, your blanket is equal in all respects to those costing many times more in the shops. Current consumption is negligible and the benefits it gives are beyond measure. Absolutely safe. Easy to make. This blanket is a boon to health and comfort.

★ SUPPRESSIT ★

(TELEVISION SUPPRESSOR KIT)

For the suppression of Domestic Motor Driven Appliances. Comprises two chokes, and two condensers mounted on a card with wiring instructions. Ideal for Vacuum Cleaners, Hairdryers, Sewing Motors, etc., up to 1 Amp. Price, 3/6. Post Free.

REPLACEMENT ELEMENTS

FOR DOMESTIC ELECTRICAL APPLIANCES

We stock over 200 types of element replacements for Fires, Irons, Kettles, Hairdryers, Toasters, and Boiling Rings. Our range includes replacements for appliances which are no longer manufactured and if you have any difficulty in obtaining the particular element you want you would be well advised to drop us a line.

WE HAVE A REPUTATION FOR HIGH QUALITY THERMOSTATS AND LIST SOME OF OUR STOCK ITEMS HERE :

THERMOSTAT, CS. Convector Thermostat for Space Heaters and Low temperature Ovens. 15 amps., 250 volts A.C. 40/80 deg. F., 25/-, post 6d.

THERMOSTAT, MB. For control of Electric Immersion Heaters up to 3 KW. 30/100 deg. F. 15 amps., 250 volts A.C. £2/0/0, post 9d.

THERMOSTAT, PP. Room Thermostat. 15 amps., 250 volts A.C. 5 1/2 in. x 1 1/2 in. x 2 in. A beautiful instrument. Temp. ranges 30/90, 40/100, 40/80, 60/100 deg. F. as required. £2/0/0, post 6d.

THERMOSTAT, BW/1. 3 amps. 250 volts A.C. For control of hot-plates, vulcanisers, etc. 50-550 deg. F. 15/6, post 4d. We are only too glad to send illustrated leaflets on any of these Thermostats if you will send a S.A.E. stating which model interests you.

AMMETERS Moving Iron. A.C./D.C. 0/5 amps., 1 1/2 in. dial. Projection mounting. Price 18/- Post 1/-. As above but 0/10 amps. Price 18/- Post 1/-.

GREENHOUSE THERMOSTAT

Type ML. Constructed especially for the amateur gardener. The scale plate is calibrated "High-Medium-Low," and has a temperature range of 40-90 deg. F. Current-carrying capacity is 10 amps. 250 v. A.C. Differential, 4 to 6 deg. F. Dimensions: 4 1/2 in. x 2 in. x 1 1/2 in. Price 35/- Post 6d.

Model PJ. Miniature Thermostat for control of domestic Electric Irons and special purpose machines where space is limited. Capacity: 5 amps. 250 v. A.C. 3/4 in. x 3/4 in. x 1 1/16 in. Single screw fixing. Price 9/3. Post 3d.

Model SN/40. 1 amp. 240 v. A.C., 50-250 deg. F., 5/6. Post 3d.

FIRE BARS

- No. 41. Bowed. 3in. x 9 1/2 in. 7/6 ea.
- No. 42. Bowed. 3in. x 7 1/2 in. 7/4 ea.
- No. 43. Bowed. 3 1/2 in. x 8 1/2 in. 7/6 ea.
- No. 44. Bowed. 3 1/2 in. x 8 1/2 in. 7/6 ea.
- No. 45. Flat. 3in. x 9 1/2 in. 7/6 ea.
- No. 46. Flat. 2 1/2 in. x 7 in. 7/4 ea.
- No. 47. Bowed. 3in. x 9 1/2 in. 9/- ea.
- No. 41. Suitable for Sunbeam, Revvo, Belling, Dudley, Swan.
- No. 42. Suitable for Small Revvo and various types.
- No. 46. Suits Belling, Brightglow.
- No. 47. Suitable for Creda.

SPIRALS

- No. 70. Spiral, 1,500 w. 2/9 ea.
- No. 70a. Spiral, 1,000 w. 2/2 ea.
- No. 70b. Spiral. 750 w. 1/10 ea.
- No. 70c. Spiral, 600 w. 1/5 ea.
- No. 70d. Spiral: 500 w. 1/4 ea.
- No. 70e. Spiral, 200 w. 1/2 ea.
- No. 70f. Spiral, 100 w. 1/1 ea.

CAR HEATER ELEMENT

No. 87. 6in. x 1 1/2 in. x 200/250 v. 100 w. ... **6/3** ea.

THE TECHNICAL SERVICES CO.
SHRUBLAND WORKS . BANSTEAD . SURREY.



S.G. Brown
SINGLE
HEADSET
with
BOOM
MICROPHONE
for:—

TELEPHONE OPERATORS
CONFERENCE INTERPRETERS
BROADCASTING TECHNICIANS

Designed with fully adjustable single earpiece and microphone. Leaves both hands free. Enables operators to listen and speak, independently.

Earpad and Microphone housings moulded from dermatitis-proof rubber. Designed to withstand very heavy wear. (Available with two earpieces if desired).

S. G. Brown provide Headphones and associated equipment for all known purposes. Brochure "P" sent on request.

S.G. Brown, Ltd.

SHAKESPEARE STREET, WATFORD, HERTS

Telephone: Watford 7241.

ANEROID BAROMETER



AS SOLD FOR 5 Gns. YOURS FOR

5/- DEPOSIT

Balance by monthly payments of 11/- or 55/- CASH.

A well-made and accurate instrument of handsome appearance and great sensitivity. Offered at half the usual price. BRAND NEW and in perfect order. Make splendid gifts.

I.C.S. TRAINED MEN are in Greater Demand than ever—Maximum production depends on high technical skill, such as that acquired by I.C.S. Students

**TENS OF THOUSANDS MORE TRAINED
MEN ARE URGENTLY NEEDED NOW
—BUT THERE IS NO WORTH-WHILE
PLACE FOR THE UNTRAINED**

*Ambitious men everywhere have succeeded through
I.C.S. Home-Study Courses. So also can you.*

The man with an I.C.S. Training in any one of the subjects listed below knows it thoroughly, completely, practically. And he knows how to apply it in his everyday work.

Accountancy
Air Conditioning
Architecture
Architectural Drawing
Boiler Engineering
Book-keeping
Building Construction
Building Specifications
Business Training
Business Management
Carpentry and Joinery
Chemistry, I. & O.
Civil Engineering
Clerk of Works
Coal Mining
Concrete Engineering
Diesel Engines
Draughtsmanship
Drawing Office Practice
Electrical Engineering

Electric Power, Light-
ing, Transmission,
Traction
Eng. Shop Practice
Fire Engineering
Foremanship
Fuel Technology
Heating and Ventilation
Hydraulic Engineering
Illumination Eng.
Industrial Management
Machine Designing
Machine-Tool Work
Maintenance Eng.
Marine Engineering
Mechanical Drawing
Mechanical Engineering
Mining Engineering
Motor Engineering
Motor Mechanics

Motor Vehicle Elec.
Municipal Engineering
Plumbing
Production Engineering
Quantity Surveying
Radio Engineering
Radio Service Eng.
Refrigeration
Salesmanship
Sanitary and Domestic
Engineering
Sheet-Metal Work
Short-Story Writing
Steam Engineering
Structural Steelwork
Surveying
Television Technology
Welding, Gas and Elec.
Woodwork Drawing
Works Engineering

Students intending to sit for examinations in Mech. Eng., Architecture, Quantities, Civil Eng., and others, should enrol NOW for preparatory Courses. Using a specially prepared Study Programme, the student studies in his spare time at his own pace and, with time for revision, sits with full confidence of success.

Courses are also available for General Certificate of Education and most other Technical, Professional, Commercial and Civil Service Exams.

(I.C.S. Examination Students are coached until successful.)

Moderate fees include ALL books required.
REDUCED TERMS TO H.M. FORCES.

If you need technical training, our advice concerning your work and your career is yours for the asking—without obligation. Let us send our special free booklet on the subject in which you are specially interested.

The successful man DOES to-day what the failure INTENDS doing to-morrow. Write to us TO-DAY
Dept. 169A, I.C.S., 71, KINGSWAY, W.C.2.

CUT HERE

INTERNATIONAL CORRESPONDENCE SCHOOLS

Dept. 169A, International Buildings, Kingsway, London, W.C.2.

Please send me free booklet on.....

Name..... Age.....
(USE BLOCK LETTERS)

Address.....

Addresses for Overseas Readers

Australia : 140, Elizabeth Street, Sydney. Egypt : 40, Sharia Abdel Khalek Sarwat Pasha, Cairo. Eire : 3, North Earl Street, Dublin. India : Lakshmi Bldg., Sir Pherozsha Mehta Rd., Fort, Bombay. New Zealand : 182, Wakefield Street, Wellington. N. Ireland : 26, Howard Street, Belfast. South Africa : Dept. L, 45, Shortmarket Street, Cape Town.

CHOOSE YOUR DYNAMO LIGHTING

—WITH THE SAME
CARE YOU CHOSE
YOUR CYCLE

No cycle is complete without efficient Dynamo Lighting. Make absolutely sure you get the best by choosing Miller. For with Miller you buy much more than a set—you also get years of unfailing service—in terms of thoroughly reliable Cycle Dynamo Lighting at all speeds.





H. MILLER & CO., LTD., BIRMINGHAM, 6

STOP!!

Pull up in time
by fitting



Fibrax

BRAKE BLOCKS

You brake gently, but firmly with FIBRAX brakes. The great thing is they are SURE in emergency. And they spell S-A-F-E-T-Y on the steepest gradients. For Steel rims, Fibrax Black Blocks; for alloy rims, Soft Red Blocks.

**FOR SAFETY'S SAKE
—FIT A SET NOW**

FIBRAX LIMITED
2 Tudor Street, London, E.C.4.

Entered into with the B.L.R.C. on 26th April, 1953.

We can only feel that this latest move is the result of "power politics" and that the sport, as a whole, will suffer considerably as a result.

At the B.L.R.C. National Executive Committee Meeting on 17th October, a resolution was passed that the racing licence for all amateurs shall be 2s. 6d.; representing a reduction of 2s. 6d. for all senior amateurs. The meeting also defined an independent rider as one who declares that he practises the sport of cycle racing whilst continuing his normal occupation. He may receive prizes in any form whatsoever, and bind himself by contract (to manufacturers) but at the same time, must belong to a club. An independent can compete only in the name of the club with which he is registered and he shall only be registered with one club. Under this definition, what is the position of an independent rider who has no occupation? Suppose he signs himself as of independent means? Or that for some reason he is not permitted to work, such as looking after aged parents? Would he be debarred from calling himself an independent?

However, following the proposals for a new overall body, the N.C.U. in acknowledgment asked whether the proposals are submitted as a basis for discussion or whether a straight yes or no to the proposals as they stand was required. The B.L.R.C. reply was that the proposals were sent as a sincere effort to reach amicable agreement and that they wished to have a straight yes or no to the individual eight points put forward, although if the N.C.U. had any particular difference of opinion on any of the points, the B.L.R.C. would be prepared to discuss them provided that the proposals are accepted in principle, and the formation of the new overall body was completed by 30th September, 1954. This would prepare the way for complete harmony in the sport at the beginning of 1955.

The Ministry of Transport has already

stated that they will not allow the two bodies to run events in competition with each other, and unless there is unified control the prospect of road racing continuing after 1955 becomes even more remote.

Model Motor Cycles—Competition Results

THERE were three classes in the competition for model motor cycles organised by the Auto-Cycle Union—Pioneer, Vintage, and Modern. Mr. F. J. Camm (editor of this journal) entered a very accurately-made scale model of the 1895 Werner, and this secured first prize in that class. The wheels are correctly spoked and nipples, the saddle is exactly to scale with tensioning screw and springs, and the chain is a scale miniature roller chain. Every detail throughout has been faithfully scaled down. Mr. Camm has donated the cash part of his award to the Auto-Cycle Union Benevolent Fund. Photographs of the three first prizewinning models in their respective classes are on the previous page. Here is a full list of prizewinners. All of the models submitted were exhibited at the recent Cycle and Motor Cycle Show.

PIONEER CLASS

First Prize of £20 and an Engraved Souvenir Plaque: Mr. F. J. Camm, of Tower House, Southampton Street, Strand, W.C.2, for his model of an 1895 WERNER.

Second Prize of £10: Mr. Manuel Olive, of Calle Rubinstein 2, Barcelona, Spain, for his model of a 1913 SUN AND SIDECAR.

Third Prize of £5: Mr. J. J. Coles, of 47, Winchendon Road, Fulham, S.W.6, for his model of a 1912 PREMIER (3 1/2 h.p.) and CANOLET SIDECAR.

VINTAGE CLASS

First Prize of £20 and an Engraved Souvenir Plaque: Mr. E. J. Graves, of 8, Roc Green Lane, Hatfield, Herts, for his model of a 1930 K.S.S. VELOCETTE.

Second Prize of £10: Mr. E. C. D. Ashton, of Lane House, Simplemarsh Road, Addlestone, Weybridge, Surrey, for his model of a 1929 T.T. SUNBEAM 500 c.c.

Third Prize of £5: Mr. A. Exelby, of c/o 481, Gilmerton Road, Edinburgh, 9, for his model of a 1929 FRANCIS BARNETT 149 c.c. For his ingenuity and originality the judges awarded a special Consolation Prize to Mr. I. Currie, of 37,

Mayfield Road, Sanderstead, Surrey, for his model of a 1930 BROUGH SUPERIOR 996 c.c. and Sidecar which was contained within the glass portion of an ordinary 6 watt motor cycle bulb.

MODERN CLASS

First Prize of £20 and an Engraved Souvenir Plaque: Mr. C. A. N. Rose, of 21, Greystoke Park Terrace, Ealing, W.5, for his model of an A.J.S. 7R.

Second Prize of £10: Mr. A. B. Bass, of 5, Oak Terrace, Grange Hill, Chigwell, Essex, for his model of a 500 c.c. NORTON.

Third Prize of £5: Mr. P. Burgess-Allen, of 6, Fulton Mews, Porchester Terrace, Bayswater, W.2, for his model of a DOUGLAS 80 Plus.

The judges "Highly Commended" the models of: Mr. W. J. Charnley, of 4, Coronation Crescent, Distington, Workington, Cumberland. (650 c.c. B.S.A. Gold Flash.)

Mr. T. W. Roelich, of 47, Welbeck Road, Doncaster, Yorks. (500 c.c. SUNBEAM 58.)

Mr. J. de Rippe Berry, of 53, North Devon Crescent, Keyham, Plymouth, Devon. (225 c.c. FRANCIS-BARNETT Cruiser.)

Mr. Manuel Olive, of Calle Rubinstein 2, Barcelona, Spain. (MONTESA BRIO 80)

and Mr. Manuel Olive, of Cal le Rubinstein 2, Barcelona Spain. (SANGLAS 350.)

N.C.U. Membership

THE N.C.U. councillors have voted in favour of £1 per club per annum for club affiliation, in an effort to retrieve the union's waning financial position. The argument arises as to whether this will achieve the object in view; whether it will not, in fact, deter individual members from affiliation. The subscription is low enough for the benefits conferred—third party insurance, legal backing and the touring, social and racing services. If all the clubs rally round, the union can afford to ignore the loss of a few hundred individual member affiliations. But will any such financial arrangement re-establish the fortunes of the N.C.U.? It is my view that members and clubs do not affiliate, not because of the sum of money involved, but because of the dictatorial attitude the club has adopted. In reality, a member gets good value for his money, but the attitude of the union over mass start has caused such disruption in the sporting side of cycling that it is unlikely to retrieve its lost prestige by its new affiliation scheme.



A Novel Cycle Drive

By D. V. PRIEST

5. 20T sprocket mounted on shaft and bearing "C" (RHS).
6. 14T sprocket mounted on shaft and bearing "C" (LHS).
7. 46T normal chain wheel.
8. 18T sprocket on hub "B" in rear wheel.
9. Driving chains.
10. Wheels 26in. x 1 1/4in.
11. Pedals and cranks.
12. Trigger cable to hub "B."
13. Trigger cable to hub "A."

THE photograph and drawings illustrate a novel form of drive which gives the rider a choice of nine gears. The initial drive goes from the normal chainwheel (46T) to the 18T sprocket on the right hand side of 3-speed hub A, see Fig. 2. From the 14T sprocket on the left hand side of hub A to the 14T sprocket on the left hand side of free running shaft, C. From the right hand side of this shaft, the drive is from a 20T to the 3-speed hub, B in rear wheel of machine.

The following is the key to Fig. 1. A and B. Sturmey Archer A-W Standard ratio 3-speed hubs fitted on special mounting "M" and rear wheel "10" respectively.

1. 3-speed trigger to hub "A."
2. 3-speed trigger to hub "B."
3. 18T sprocket fitted to hub "A" on RHS.
4. 14T sprocket fitted to hub "A" on LHS.

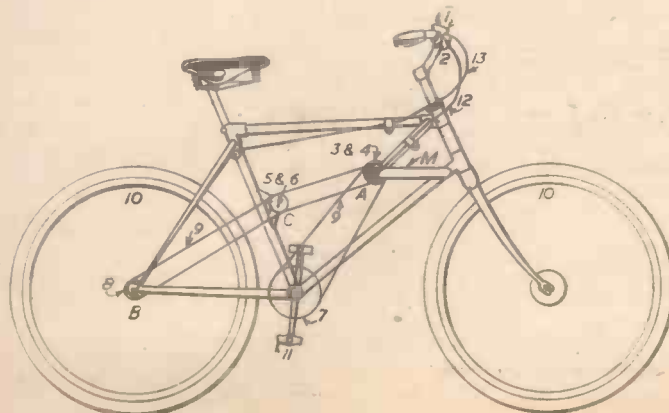

Fig. 1.—A diagrammatic side view.

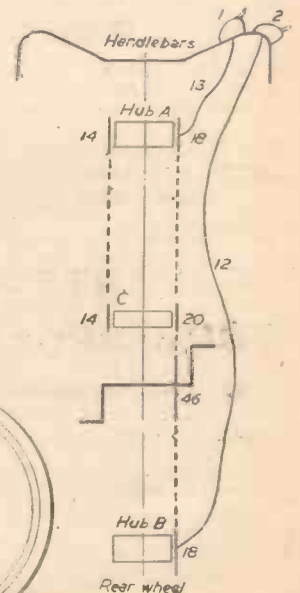

Fig. 2.— Plan view showing layout of chain and sprocket positions.

An Old Story

SO every motor vehicle must now wear a couple of reflectors, one each side of the rear, denoting roughly the width of the car. Curious how night eyesight must have improved during the last two decades, because when Noel-Baker fastened live rear lights on cyclists, he said, and most motorists agreed with him, that cyclists and their reflectors could not be seen. The reflector has not improved since that date, so we must conclude either the average driver has grown more perfect optically, or the old prejudice against the reflector has died as a result of its continued use on telegraph poles, bridge-ends and cat's eyes. The latter, of course, is the explanation; it is, as we said at the time of the rear light controversy, the perfect warning, better even than the live light, and now it seems we are being proven correct by the very folk who were our most vigorous critics.

The time is past when we can be relieved of live rear lights; they are fastened on us for ever I suppose, but one cannot refrain from a little dig at the know-alls of yesterday. In any case, let us forget it and only remember that one small injustice to the cycling tribe makes us chary of any movement for our protection from people who never knew, or have forgotten the practice of cycling. But it is ironic that the thing they condemned now becomes a symbol of safety to the condemners if their live rear lights should fail!

Sartorial Fashions

THE cool mornings and evenings when gloves are a comfort are here. Soon it will be jersey time, preferably those with long sleeves to keep the wind from streaming up our arms, and then, when winter really sets in, I shall be grateful for the Grenfell coat and the sheepskin gloves. How the "tribe of shortists" keep warm in arctic conditions puzzles me, and sometimes I envy them the possession of heated blood streams when they tell me they are comfortable. If they are happy while riding, what happens when they stop for a meal? Even if there is a fire to help warm the air, they cannot all get close enough to expect to remove the blue tinge from chilled legs. Perhaps, being old, I don't understand these sartorial cycling fashions, and that may be the answer. I do know, however, that to enjoy my riding in the cooler weather I must be warm, and if it happens I am too warm I can always shed a garment and add a little additional cargo to the bag. These are the kind of thoughts that move the mind when the autumnal chill invades the air, and I cannot but think there would be more winter wanderers if this matter of cycling attire were not quite so rigid, and the club folk were less determined to ape the fashion they have inaugurated.

Lacking Fire and Purpose

RECENTLY a cyclist and a motorist argued their respective points of view on TV but, in my opinion, the performance was disappointing. The motorist wanted all cyclists number-plated (which, of course, means taxation) so that identification would be simplified in case of accident. He cited a case where a Dutch rider tried to evade identification after causing an accident witnessed by the speaker, but the number plate on his bicycle brought him to justice. This was his case for imposing taxation on 12 million people, a case unsupported by data, and so puny that to me it was almost laughable. Unfortunately, also in my view, the cyclist's reply was feeble, for surely such a charge deserved nothing more than the laughter of scorn

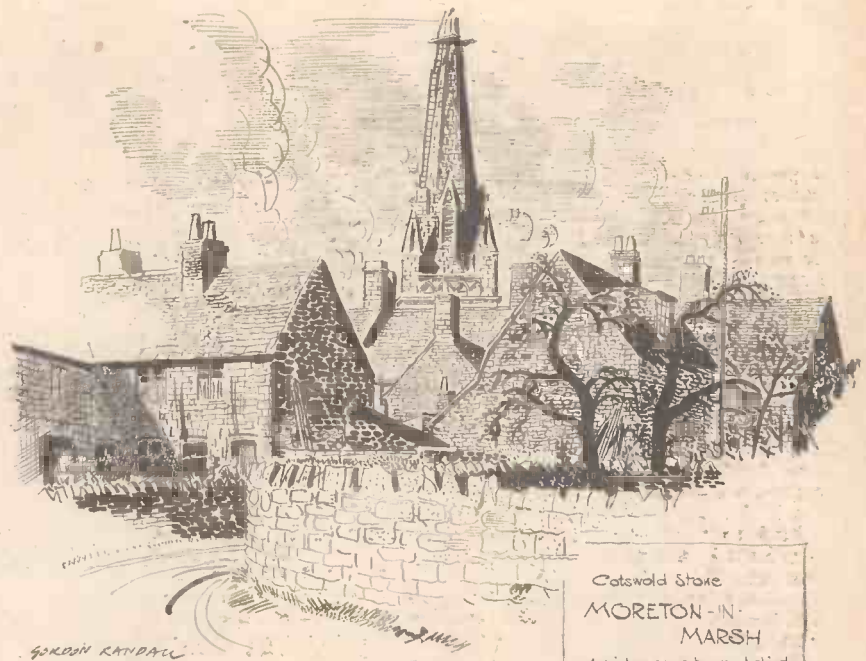

GORDON RANDALL

Cotswold Stone
MORETON-IN-MARSH
A picturesque by-way behind the great wide high street of this fine Gloucestershire town.

Wayside Thoughts

By F. J. URRY, M.B.E.

rather than some little detail of what organised cycling is doing to teach the younger generation the rules of the road. But let us try to be fair. B.B.C. editing probably takes all the real argument out of such controversy, and so probably the performers are not to blame for a very weak display. Personally, I would not lend myself to this kind of thing unless I could completely interpret my thoughts and argue the matter with the force of conviction. To give six minutes' time to such a subject is just waste of six minutes. No one interested on either side of the controversy is any wiser, or less determined, prejudiced, or what you will, on their particular point of view at the end of the story.

The Old Roads

A FEW nights ago a young friend called in to return some road maps of Scotland he had borrowed, and we spent an hour or so exchanging experiences on, or rather reactions to, that land of beauty. A sudden call had taken him to Dundee, and with a few days left after settling his troubles he wandered up Glen Affric, and made the journey from Fort William to Mallaig, routes he had never previously travelled but of which he had heard me speak.

I have not been up Glen Affric since the hydro-electric schemes were completed; indeed, last time I was that way it was as Nature made it after the ice age, so I was very glad to hear that he considered it the most lovely glen he has ever traversed. I thought that, too, in 1925 when the road was very rough and riding a gymnastic exercise in steering; but he tells me the way is smooth to beyond Affric Lodge, and his only regret was he had to return because of time, for he had an urge to go over the moorlands to Loch Duish, a full day's tramp, with fine weather necessary to make the journey in reasonable condition. He had the luck of the weather on the road to the Isles, and agrees that the 40 miles from Corpach to Mallaig is the most

beautiful road in Britain. But on the return journey next day he had some little difficulty in getting through on account of floods.

And that was a pity, because no one can say they know the loveliness of this road until they have ridden it both ways.

The Quiet Beauty of It

I RECENTLY spent a family holiday in Galloway, and there was no cycling. I missed my bicycle, but in the circumstances was not too badly served, for the motoring (except getting there) was very leisurely, and as all the days but one were either sprinkled or swilled with rain, it did not much matter. Galloway is still in the remote class of touring country and its fine roads and by-ways are as quiet as they are lovely. It is a beautiful corner of Scotland that appears to be bypassed by the people in a hurry to get to the Highlands, and though a few coaches have penetrated they are rare, and on the lesser roads are never seen. It is these ways that give the wanderer a real sense of the beauty of these shires, Dumfries, Kirkcudbright and Wigton. You are seldom 20 miles from the sea, and the twists and turns of this Solway-side and its immediate mountains means the winds are as often with as against you.

I think most cycling tourists would love the pleasant pastures of Galloway; within a few miles it can change outline and outlook to "Caledonia stern and wild." There are, of course, no big through routes, and beyond Dumfries the serving roads are mainly for the agricultural traffic; cattle trucks being the off-met items. The small townlets are interesting, being largely self-sufficient, with an artist colony at Kirkcudbright. Here, pottery and pictures interested my friends and reduced the weight of my note-case. Accommodation appeared plentiful and the welcomes were warm, but it is only fair to say prices are not by any means low. It was a happy little holiday in a watery period, and when the storms did thresh—and they surely did—I was not sorry for a roof. But how good it was to pattern a pedal circle on the Sunday after my return.

"ZYTO" B.G.S.C. LATHES BRITAIN'S FINEST LATHE VALUE

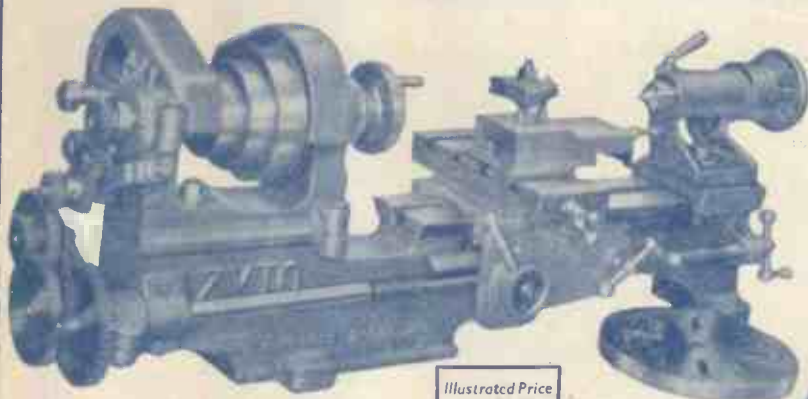

THE "ZYTO 16" LATHE

Height of centres	38 in.
Distance between centres	16 in.
Height from gap	4 1/2 in.
Height from Saddle	2 in.
Guide Screw	8 T.P.I.
Headstock Mandrel Admit	1 in.
Tailstock Barrel Admit	1 in.
Headstock Pulley, 3-speed	3/4 in. flatbelt
Faceplate, dia.	8 in.
Overall length of Lathe	34 in.
Change Wheels: 20, 25, 30, 35, 40, 45, 50, 55, 60, 65.	

Complete Gear Guard, Extra long Compound Slide rest. Gear Chart included.

Cash Price **32/10/0**

or first payment of **£8/10/0**
balance payable over 12 months.

Illustrated Price
List of Tools for
all trades. Free
and Post Free.

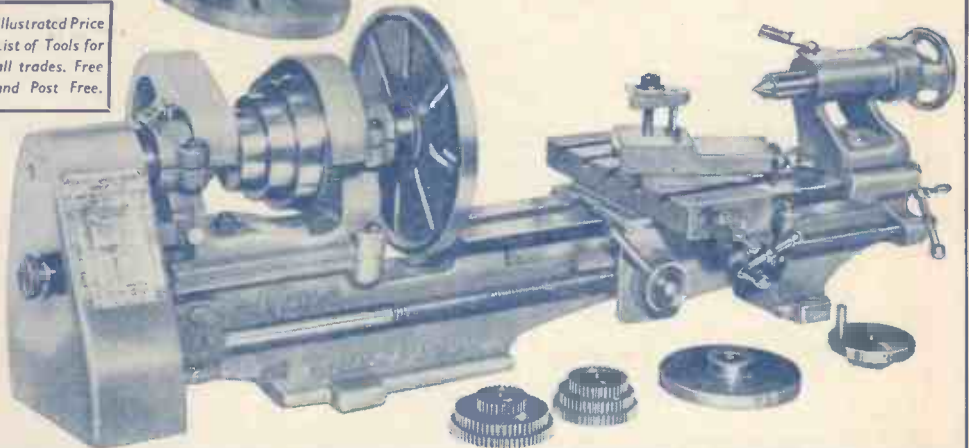

★ *Accurate & Dependable* ★
★ **12 1/2" 16" BETWEEN CENTRES** ★
Cash Price **26/0/0** or first payment of **£7** balance payable over 12 or 18 months

THE "ZYTO 12" LATHE

Height of centres	23 in.
Distance between centres	12 1/2 in.
Height from gap	4 1/2 in.
Height from Saddle	2 in.
Guide Screw	8 T.P.I.
Headstock Mandrel Admit	1 in.
Tailstock Barrel Admit	1 in.
Headstock Pulley, 3-speed	3/4 in. flatbelt
Faceplate, dia.	6 in.
Overall Length of Lathe	30 in.
Change Wheels: 20, 25, 30, 35, 40, 45, 50, 55, 60, 65.	

Back Geared Guards and Change Wheels, together with Catch Plate and Finished Back Plate for Chuck are all included.

S. TYZACK & SON LTD 341, 343 & 345, OLD STREET, LONDON, E.C.1.
Telephone: SHOREDITCH 8301 (10 lines)



THORNTON'S DRAWING INSTRUMENTS

PIC SLIDE RULES

We are the largest manufacturers of high-grade Drawing Instruments and Slide Rules in the British Empire, and our Kinwest Drawing Materials have gained a reputation throughout the world for superb quality and accuracy. Insist on using only Thornton's for complete satisfaction.

Our illustrated Catalogue which includes particulars of Drawing Instruments, Drawing Boards, Tee and Set Squares, Scales, Curves, etc., is sent Post Free on request.

A. G. THORNTON LTD
Drawing Instrument Specialists
WYTHENSHAW, MANCHESTER
Tel: WYThenshawe 2277 (4 lines)

*It's exciting to see
your photos in colour!*



Yes, and you can colour them yourself, too! You'll find it so easy with Johnson Photo Tints. Ordinary black and white prints can be transformed into vivid colours—makes something really surprising to show your friends! You can obtain any desired tone by blending the tints. The smaller Johnson Photo Colouring Outfit contains 9 small bottles of normal strength tints and a camel-hair brush—everything you want to make a start. Price **5/6**

There is also a more expensive set consisting of 12 one ounce bottles of triple strength tints with two camelhair brushes, and two china palettes. Price **19/6**

JOHNSONS OF HENDON LTD

Full instructions are enclosed with each set and individual tints can be replaced.
THE WORLD FAMOUS MANUFACTURERS OF PHOTOGRAPHIC CHEMICALS, APPARATUS AND ACCESSORIES
LONDON N.W.4. Established 1743

"Practical Mechanics" Advice Bureau. **COUPON**
This coupon is available until December 31st, 1954, and must be attached to all letters containing queries, together with 6d. Postal Order. A stamped, addressed envelope must also be enclosed.
Practical Mechanics. December, 1954.

Free Guide — SUCCESS IN ENGINEERING

One of the following Courses taken quietly at home in your spare time can be the means of securing substantial well-paid promotion in your present calling, or entry into a more congenial career with better prospects.

ENGINEERING, RADIO, AERO, ETC.

Aero. Draughtsmanship Jig & Tool Design Press Tool & Die Design Sheet Metalwork Automobile Repairs Garage Management Works M'gmt. & Admin. Practical Foremanship Ratefixing & Estimating Time & Motion Study Engineering Inspection Metallurgy Refrigeration Welding (all branches) Maintenance Engineering Steam Engine Technology I.C. Engine Technology Diesel Engine Technology Ordnance Survey Dr'ship.	Elec. Draughtsmanship Machine " " Automobile " " Structural " " R/F Concrete " " Structural Engineering Mathematics (all stages) Radio Technology Telecommunications Wiring & Installation Television Radio Servicing Gen. Elec. Engineering Generators & Motors Generation & Supply Aircraft Mainten. Licences Aerodynamics Electrical Design
--------------------------------------------------------------------------------------------------------------------------------------------------------------------------------------------------------------------------------------------------------------------------------------------------------------------------------------------------------------------------------------------------------------------------------------------------------------------	---------------------------------------------------------------------------------------------------------------------------------------------------------------------------------------------------------------------------------------------------------------------------------------------------------------------------------------------------------------------------------------------------

BUILDING AND STRUCTURAL

L.I.O.B. A.M.I.San.E. Building Construction Costs & Accounts Surveying & Levelling Clerk of Works Quantity Surveying	A.I.A.S. A.A.L.P.A. Building Construction Costs & Accounts Surveying & Levelling Clerk of Works Quantity Surveying	A.R.San.I. L.A.B.S.S. Builders' Quantities Carpentry & Joinery Building Inspector Building Draughtsmanship Heating and Ventilating	M.R.San.I. A.R.I.C.S. Builders' Quantities Carpentry & Joinery Building Inspector Building Draughtsmanship Heating and Ventilating
----------------------------------------------------------------------------------------------------------------------------------------	--------------------------------------------------------------------------------------------------------------------------------------	------------------------------------------------------------------------------------------------------------------------------------------------------	------------------------------------------------------------------------------------------------------------------------------------------------------

GENERAL, LOCAL GOVERNMENT, ETC

Gen. Cert. of Education Book-keeping (all stages) College of Preceptors Woodwork Teacher Metalwork Teacher Housing Manager (A.I.Hsg.)	Common. Prelim. Exam. A.C.L.S., A.C.C.S. A.C.W.A. (Costing) School Attendance Officer Sanitary Inspector Civil Service Exams.
------------------------------------------------------------------------------------------------------------------------------------------------------	----------------------------------------------------------------------------------------------------------------------------------------------

BECOME A DRAUGHTSMAN—LEARN AT HOME AND EARN BIG MONEY

Men and Youths urgently wanted for well paid positions as Draughtsmen, Inspectors, etc., in Aero, Jig and Tool, Press Tool, Electrical, Mechanical and other Branches of Engineering. Practical experience is unnecessary for those who are willing to learn—our Guaranteed "Home Study" courses will get you in. Those already engaged in the General Drawing Office should study some specialised Branch such as Jig and Tool or Press Tool Work and so considerably increase their scope and earning capacity.



★ OVER SIXTY YEARS OF CONTINUOUS SUCCESS ★

NATIONAL INSTITUTE OF ENGINEERING

(Dept. 29)

148, HOLBORN, LONDON, E.C.1

SOUTH AFRICA: E.C.S.A., P.O. BOX 'NO. 8417, JOHANNESBURG

FOUNDED 1885 - FOREMOST TODAY

132-PAGE BOOK FREE! SEND FOR YOUR COPY

This remarkable FREE GUIDE explains :

- ★ Openings, prospects, salaries, etc., in Draughtsmanship and in all other branches of Engineering and Building.
- ★ How to obtain money-making technical qualifications through special RAPID FULLY-GUARANTEED COURSES.

MANY INTERESTING COURSES TO SELECT FROM!

A.M.I.Mech.E., A.M.I.M.I.,
 A.M.Brit.I.R.E., A.M.I.P.E.,
 A.M.I.C.E., A.M.I.Struct.E.,
 A.M.I.Mun.E., M.R.San.I.,
 A.M.I.E.D., A.F.R.Ae.S.,
 London B.Sc., Degrees.

Fully guaranteed postal courses for all the above and many other examinations and careers. Fully described in the New Free Guide



THE ACID TEST OF TUTORIAL EFFICIENCY SUCCESS—OR NO FEE

We definitely guarantee that if you fail to pass the examination for which you are preparing under our guidance, or if you are not satisfied in every way with our tutorial service—then your Tuition Fee will be returned in full and without question. This is surely the acid test of tutorial efficiency.

If you have ambition you must investigate the Tutorial and Employment services we offer. Founded in 1885, our success record is unapproachable.

**ALL TEXTBOOKS ARE SUPPLIED FREE
 PROMPT TUTORIAL SERVICE GUARANTEED
 NO AGENTS OR TRAVELLERS EMPLOYED**



Free Coupon

To : NATIONAL INSTITUTE OF ENGINEERING
 (Dept. 29), 148-150, Holborn, London, E.C.1.

Please Forward your Free Guide to

NAME.....

ADDRESS.....

My general interest is in : (1) ENGINEERING
 (2) AERO (3) RADIO (4) BUILDING
 (5) MUNICIPAL WORK



(Place a cross against the branches in which you are interested.)

The subject of examination in which I am especially interested is

To be filled in where you already have a special preference.
 (1)d. stamp only required if unsealed envelope used.)