

A SENSITIVE RESISTANCE BRIDGE

NEWNES

# PRACTICAL MECHANICS

1/4

EDITOR: F. J. CAMM

APRIL 1951



## PRINCIPAL CONTENTS

An Electronic Alarm Unit

A Camera View-meter

B.R. New Standard Locomotive

Radio-controlled Models

Model Engineering Practice

Building Aluminium Boats

World of Models

Queries and Enquiries

Cyclist Section



**THAT CLIP YOU NEED**



**IS MADE BY**



**TERRY'S** *(the Spring people)*

*and 3 Special Clips*

Two very popular types, 80 and 81. In a range of sizes from  $\frac{1}{2}$ " to 2" from stock. No. 300 is a very popular drawing board clip with a host of additional uses. 5/- a doz. (incl. P.T.) from stock.



Clips in every shape, size and form . . . steel clips, bronze clips, stainless clips, little clips, big clips, clips made exactly as you want them. If you desire it we can design any kind of clip to your own exact specification. (We've been designing clips for 95 years!)

Sole Makers:  
**HERBERT TERRY & SONS LTD.,**  
 REDDITCH  
 London • Birmingham • Manchester

WANT TO KNOW ALL ABOUT SPRINGS? HERE IS THE MANUAL — 10/6 POST FREE.



# TYZACK'S 'ZYTO' MACHINERY



Back geared, with tumbler reverse, hollow mandrel and tailstock, fully compound slide rest rack feed set over tailstock. 12 1/2 in. between centres.

**6/10/0**

First Payment and 12 Payments of 35/10  
Cash Price 25/10/0

### DIMENSIONS

Height of centres	3 1/2 ins.
Distance between centres	12 ins.
Height from gap	4 1/2 ins.
Height from saddle	2 ins.
Guide screw	8 T.P.I.
Headstock mandrel admits	1/2 ins.
Tailstock barrel admits	1/2 ins.
Headstock pulley, 3 speeds	1/2 in. flat belt
Faceplate—diameter	6 ins.
Overall length of lathe	30 ins.

FULLY ILLUSTRATED LEAFLET FREE AND POST FREE ON REQUEST.

### SPECIAL TOOL LIST FREE & POST FREE

The "ZYTO" motorised precision saw bench will rip, crosscut, groove, mitre, chamfer, etc. Table size, 18 in. x 14 in. Takes 10 in. saw blade. Right and left mitre slide. Long rip fence. 1 h.p. motor, 3 phase, with vee-belt drive and built in dust chute.

£9/10/9

First payment, and twelve payments of 54/9 cash price £39/18/9

Other voltages can be supplied.

Extension tables, as illustrated, £3/15/0 extra.



Telephones Clerkenwell 8301 Ten Lines

## S. TYZACK & SON LTD

341-345 OLD ST. LONDON E.C.1

# MODEL POWER BOATS

CENTRE FLUE LAUNCH BOILER

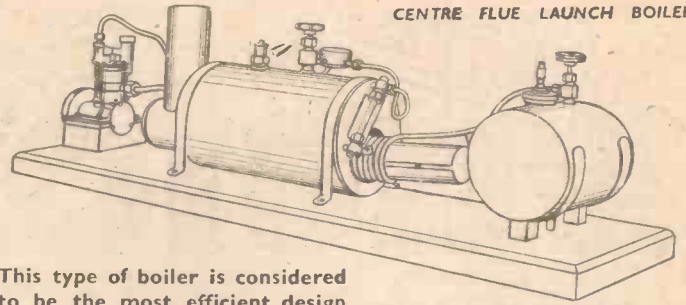

This type of boiler is considered to be the most efficient design for power boats. It is made of solid drawn copper tube, is brazed throughout and every unit is tested to 150 lbs. pressure.

The illustration shows the boiler connected to our 1/2 in. bore by 1/2 in. stroke Uniflow Engine, but it is capable of steaming an engine having a 1 in. bore and stroke double acting cylinder.

### Specification

Fittings include Safety Valve, Regulator, Pressure Gauge and Syphon, Water Gauge and Check Valve.

Length 6 1/2 inches.  
Diameter 3 1/2 inches.

Height over funnel 5 1/2 inches.  
Weight 3 1/2 lbs.

Price £5.18.0, Purchase Tax £1.7.8.

Write for new edition of "Model Ships" Catalogue (MSC/12), price 1/-. For full range of other models and accessories write for our popular "Model Supplies" catalogue (MS/12), price 6d.

## BASSETT-LOWKE LIMITED NORTHAMPTON

LONDON 112, High Holborn, W.C.1.

MANCHESTER 28, Corporation Street.

# The Leytool HAND DRILL



The "Leytool" Hand Drill Brace is a noteworthy improvement on all previous hand drills. Well balanced, with a comfortable grip that fits snugly into the hand, it is compact in size and is positively a pleasure to use. Solid one-piece die-cast body. All gears accurately cut and totally enclosed. Specially hardened chuck spindle and jaws. Self-lubricating bearings. Takes drills up to 1/4-inch diameter. Standard of manufacture equal to a high-grade precision tool for accuracy. 27/6

If any difficulty in obtaining locally, send your order direct, or write for fully descriptive booklet.

Patent No. 587049

### OTHER LEYTOOLS



### LEYTOOLS are QUALITY TOOLS

All Leytools are entirely original and patented designs. Write for free illustrated booklet.

LEYTONSTONE JIG & TOOL CO., LTD., High Road, Leyton, London, E.15  
Telephone: LEYtonstone 5022-3-4

ALL AMATEUR PHOTOGRAPHERS SHOULD TRY THIS WONDERFUL NEW DEVELOPER

# Unitol

A CONCENTRATED LIQUID FINE GRAIN DEVELOPER



A one-solution, fine grain developer with excellent keeping qualities and always instantly ready for use. Dilute one ounce with just the right amount of water to fill YOUR tank, develop the film and pour the solution away. No trouble, no waste. Gives maximum speed consistent with fine grain and yields negatives of superlative enlarging quality. No filtering or dissolving necessary. A standardized technique gets you the same superb results every time.

225 cc. (8 oz.) size.....3/6  
570 cc. (20 oz.) size.....6/6

Get the UNITOL CALCULATOR with your first bottle of Unitol. It gives the right developing time for any film in any tank at all dilutions. It only costs 4d. and your dealer will be able to supply.

JOHNSONS OF HENDON LTD.  
LONDON, N.W.4. ESTABLISHED 1743

ONE ounce for ONE film then

POUR IT AWAY





# X-acto

HOBBY KNIVES & TOOLS . . .

**MORE** skill at your fingertips



Just try the scalpel-keen sharpness of X-acto blades and enjoy the perfect balance of precision engineered knives and tools. You'll feel the extra skill they put in skilful hands. You'll know the pride of better workmanship.

Whatever your hobby—model making, leathercraft, wood carving, or any other handicraft—you can make your hands more creative with "designed-for-the-job" X-acto knives and tools. Illustrated are the three X-acto knives. A card to us will bring you a folder showing the whole wide range of X-acto knives, tools and sets.

**No. 5 Knife**  
for really heavy duty. Takes all blades, the six gouges, the four routers and the two punches. With one No. 19 blade, **5/6**

**No. 2 Knife**  
for normal cutting. Takes all thirteen blades. With one No. 22 blade, **2/6**

**No. 1 Knife**  
for light and delicate work. Takes blades Nos. 10, 11, 16 and 17. With one No. 11 blade, **2/6**

★ X-acto blades are available separately in packets of 5 short blades 2/6 and 2 long blades 1/3.

TRIX LTD., 11 OLD BURLINGTON ST., LONDON, W.1.

## LAWRENCES

**STAGGERING OFFER !!!**—A wonderful assortment of valuable Aircraft Instruments including Aneroids, Gauges and other intricate types. Eight instruments, really worth over £10, to clear at 9/6 the parcel, plus postage, 1/6.

**NEW AMERICAN AIR BLOWERS**—3in. 24 v. D.C. (run on A.C. with transformer). Precision motor with ball races. Di. 2in., diam. x 4in. long. Superbly engineered. 12/6 each.

**SPERRY AUTOMATIC COMPUTING BOMBSIGHTS, TYPE K4.**—An exceptionally intricate electro-mechanical optical unit, approx. 18in. cube, contains a large number of miniature to medium-size ball races, pinions, wormwheels, rack and pinions, differentials. Also projection lamp, lenses, miniature gear boxes and sensitive clutches. This is the one-time top secret bomb sight made in America at fabulous cost; the complex construction and quality has to be seen to be believed. Model makers, engineers, do not miss this item at only 50/- each.

**NEW AMERICAN BOX KITES.**—Large size, folding alloy frame. The type that really fly high. 11/- each.

**NEW IMMERSION HEATERS.**—Tubalox, 220 v. 840 watts. Given away at 7/6 each.

**A.M. EBONITE DRAUGHTSMANS RULERS.**—1in. dia. Uncalibrated, 2/6.

**SMITHS REVOLUTION INDICATORS.**—Dial readings up to 5,000 r.p.m., 7/6.

**FLEXIBLE DRIVE SHAFTS.**—Suitable for small hand tools up to 5ft. long, 5/-.

**NEW AMERICAN STAR IDENTIFICATION INSTRUMENTS.**—Complete in leather case, 5/-.

**NEW AMERICAN HAND GENERATORS.**—Fitted with precision gear box, speed governor, etc. Precision dynamo, fitted ball bearings, provides outputs of 28 v. D.C. and 300 v. D.C. Complete with hand crank, 15/-.

**NEW AMERICAN RELAYS.**—Made by Leach, etc. 6 well assorted types, 13/- the package.

**NEW PHOTOMULTIPLIER CELLS, TYPE 931A.**—High vacuum type with high response in visible region. Gain over 1 million. Great sensitivity, low noise level, freedom from distortion, low dark current and small size. Ideal for film scanning, colorimetric measurements, spectography, astronomical measurements. Alpha particle counting and facsimile transmission, etc. Direct equivalent to type 27MI, complete with holder, resistance network, lightproof chamber and circuit, 23/-.

Experienced Export shippers. All prices include U.K. carriage. TERMS: Cash With Order. Satisfaction guaranteed or money immediately refunded.

**LAWRENCES, 61, BYROM STREET, LIVERPOOL, 3**

Telephone: CENTral 4430

## S.G. BROWN

Precision

### Sapphire Needle

For high Fidelity of Reproduction with minimum of wear on the record



### FIVE TYPES TO CHOOSE FROM

The above are designed and manufactured to suit all types of pick-ups.

- No. 1. "Miniature" jewel tipped needle for *light-weight* pick-up.
- No. 2. "Straight" jewel tipped needle for *crystal* pick-up.
- No. 3. "Trailer" jewel tipped needle for *medium-weight* pick-up.
- No. 4. "Knee Bend Trailer" jewel tipped needle for the older *heavy-weight* pick-up.
- No. 5. "Miniature Solid Sapphire" needle for *light-weight* pick-up.

PRICES:— Nos. 1-4, 7/- plus Purchase Tax 3/1. Postage 6d.  
No. 5, 9/3 " " " 4/1. " 6d.

Your local dealer can supply.  
In cases of difficulty, apply direct.

### A "TIP" WORTH TAKING

An interesting and instructive Brochure giving advice on the choice of a S. G. Brown precision Sapphire Needle to suit your pick-up will be sent on request. Write Department "P.M."

Telephone:  
Watford  
7241.

**S.G. Brown, Ltd.**

SHAKESPEARE STREET, WATFORD, HERTS



**THORNTON'S DRAWING INSTRUMENTS**

# PIC SLIDE RULES

We are the largest manufacturers of high-grade Drawing Instruments and Slide Rules in the British Empire, and our Kinwest Drawing Materials have gained a reputation throughout the world for superb quality and accuracy. Insist on using only Thornton's for complete satisfaction.

Our illustrated Catalogue, which includes particulars of Drawing Instruments, Drawing Boards, Tee and Set Squares, Scales, Curves, etc., is sent Post Free on request.

## A. G. THORNTON LTD

*Drawing Instrument Specialists*  
WYTHENSHAW, MANCHESTER  
Tel: WYThenshawe 2277 (4 lines)

### FRANK'S of GLASGOW

#### SELECTED MISCELLANEOUS ITEMS

- PRISMATIC ELBOW TELESCOPES**  
Power 7 x. Weight 6 lb. Image erect. Definition is crisp and free from distortion. Post free ... .. 27 6
- HAND SIGNALLING LAMPS**  
Diameter of reflector 5in. Bulb pre-focus 12 volt, 36 watt. This lamp gives a brilliant beam and is suitable for use as spotlight, inspection lamp, etc. Cover glass available in green, amber or clear. Post 1/- extra ... 15 0
- 1/6th H.P. ELECTRIC MOTORS**  
Hoover repulsion/induction with automatic overload cut-out. 240 v.-250 v., 1,425 r.p.m. Single-phase A.C. Mounted on rubber cushion, sprung cradle ensuring silent running. New and unused, although outer casing is slightly soiled. Inc. carriage ... .. 4 9 6
- HOOVER BLOWER MOTORS (Ex-Govt.)**  
12 and 24 v. A.C./D.C. Overall length. Suitable for ventilation, car heater system, etc. Used but in sound condition. Post free ... .. 14 6
- POCKET FOCUSING MICROSCOPES**  
A precision instrument constructed in our own workshops. The optical system consists of 8 lenses (4 achromatic doublets). Definition is crisp and free from colour and distortion. Magnification 20 x. Post free ... .. 27 6
- ASSORTED LENSES & PRISMS**  
Parcel of 10 assorted lenses and prisms. The lot. Post free ... .. 10 0

SATISFACTION ON ALL PURCHASES OR REFUND OF PAYMENT

*Charles Frank*

67-73 SALT MARKET, GLASGOW, C.I.

PHONE: BELL 2106

INSTRUMENT MAKERS AND DEALERS SINCE 1907

# One plastic material



## MAKES MANY PERMANENT MODELS

and utility objects, from simple instructions in illustrated Booklet—please read below.



## ONLY 4<sup>D</sup> IN STAMPS BRINGS BOOK

... showing how such models as those above, and many others, can be made, without skill or special tools, from Sankey's PYRUMA Plastic Cement. Ready for immediate use in its plastic state, Pyruma sets or bakes to stone-hardness, and can be painted or enamelled in all colours according to instructions. Therefore realistic natural-colour models can be made from Pyruma, including

HOUSES, BUILDINGS, FOR MODEL RAILWAYS, DOCKS AND AIRPORTS, SHIPS, MODEL FURNITURE, ANIMALS, FIGURES, RELIEF MAPS, Etc. as well as utility objects such as ASH TRAYS, BOOKENDS, MENU HOLDERS, PAPER WEIGHTS, ORNAMENTS and DECORATIVE OBJECTS.

Pyruma is inexpensive, and easily obtainable in tins from Ironmongers, Art Material Dealers and Hobbies Shops. Send 4d. in stamps to the address below for illustrated Instruction Book.



Dept. 4

**J.H. SANKEY & SON, L<sup>TD</sup>**

ILFORD

EST. 1857

ESSEX

# I.C.S. TRAINED MEN are in Greater Demand than Ever

—Maximum production depends on high technical skill, such as that acquired by I.C.S. Students

**TENS OF THOUSANDS MORE TRAINED MEN ARE URGENTLY NEEDED NOW—BUT THERE IS NO WORTH-WHILE PLACE FOR THE UNTRAINED**

*Ambitious men everywhere have succeeded through I.C.S. Home-Study Courses. So also can you.*

The man with an I.C.S. Training in any one of the subjects listed below knows it thoroughly, completely, practically. And he knows how to apply it in his everyday work.

- |                         |  |                                   |
|-------------------------|--|-----------------------------------|
| Accountancy             | Draughtsmanship                        | Motor Engineering                 |
| Advertising             | Drawing Office Practice                | Motor Mechanic                    |
| Air and Vacuum Brakes   | Electrical Engineering                 | Motor Vehicle Elec.               |
| Air-Conditioning        | Electric Power, Lighting, Transmission | Municipal Eng.                    |
| Arable Farming          | Traction                               | Plastic                           |
| Architecture            | Eng. Shop Practice                     | Plumbing                          |
| Architectural Drawing   | Fire Engineering                       | Quantity Surveying                |
| Auditing                | Foremanship                            | Radio Engineering                 |
| Boiler Engineering      | Free-Lance Journalism                  | Radio Service Eng.                |
| Book-keeping            | Fuel Technology                        | Refrigeration                     |
| Building Construction   | Heating and Ventilation                | Sales Management                  |
| Building Specifications | Horticulture                           | Salesmanship                      |
| Business Training       | Hydraulic Engineering                  | Sanitary and Domestic Engineering |
| Business Management     | Illumination Eng.                      | Sheet-Metal Work                  |
| Carpentry and Joinery   | Industrial Management                  | Short-Story Writing               |
| Chemical Engineering    | Lettering                              | Steam Engineering                 |
| Chemistry, I. & O.      | Machine Designing                      | Structural Steelwork              |
| Civil Engineering       | Machine-Tool Work                      | Surveying                         |
| Clerk of Works          | Marine Engineers                       | Telegraph Engineering             |
| Coal Mining             | Mechanical Drawing                     | Television Technology             |
| Commercial Art          | Mechanical Engineering                 | Welding, Gas and Elec.            |
| Concrete Engineering    | Mine Surveying                         | Woodworking Drawing               |
| Diesel Engines          | Mining Engineering                     | Works Engineering                 |

And most of the Technical, Professional, Commercial and Civil Service and Educational Examinations.  
(I.C.S. students preparing for Examinations are coached till successful)

If you need technical training, our advice on any matter concerning your work and your career is yours for the asking—free and without obligation. Let us send you our special free booklet on the subject in which you are specially interested. **DON'T DELAY. Make ACTION your watchword.**

The successful man **DOES** to-day what the failure **INTENDS** doing to-morrow. Write to us **TO-DAY**

----- Use this Coupon -----  
**INTERNATIONAL CORRESPONDENCE SCHOOLS LTD.**  
Dept. 95, International Buildings, Kingsway, London, W.C.2.

Please send me the free booklet describing your Courses in

Name ..... Age.....  
(USE BLOCK LETTERS)

Address .....

- Addresses for Overseas Readers**  
Australia: 140, Elizabeth Street, Sydney.  
Egypt: 40, Sharia Abdel Khalek Sarwat Pasha, Cairo.  
Eire: 13, Anglesea Street, Dublin, C.4.  
India: Lakshmi Bldgs., Sir Pheroosha Mehta Rd., Fort, Bombay.  
New Zealand: 182, Wakefield Street, Wellington.  
N. Ireland: 26, Howard Street, Belfast.  
South Africa: 45, Shortmarket Street, Cape-Town.



# The acid-free cored solder for every handyman

This new non-resin cored solder is an indispensable addition to every home workshop, replacing stick solder and fluid and paste fluxes. It contains two cores of Arax Flux, a flux so fast that Arax Multicore Solder can even be used for soldering blued spring steel without pre-cleaning. Flux continuity is assured, there is no waste, and no extra flux is required. If desired, the flux residue can be easily washed off with water.



SIZE 8 CARTON 5/- EACH



2/- KIT

A COMPLETE RANGE OF MULTICORE SOLDERS IN THIS SINGLE HANDY KIT  
*The Multicore 2/- Solder Kit contains two specifications of Arax Multicore for metal soldering and two specifications of Ersin Multicore for electrical and radio work.*

**MULTICORE SOLDERS LTD.**  
MELLIER HOUSE, ALBEMARLE ST., LONDON, W.1 REGent 1411

## "KARLENITE" PLASTIC MARBLE

The entirely new Artificial Stone for casting Bookends; Ashtrays; Wall-vases; Statuettes, etc. "Karlenite" sets granite-hard with a scintillating crystalline structure which very closely resembles marble or alabaster. It is enormously strong; highly resistant to heat and impervious to water. Literally any type of natural "veining" can be simulated in any colour and a range of pigments is available for this purpose.

### MAKE YOUR OWN FLEXIBLE MOULDS IN "ELASTOMOULD" SYNTHETIC RUBBER

Prepared in liquid form for making permanent elastic moulds. Ideal for repetition-casting Plaques, Bookends, etc., in plaster, cement or "Karlenite." It will faithfully reproduce even the most minute details of ornamentation and surface texture. "Elastomould" is incredibly simple to use and moulds can be taken from any type of pattern, including wood, metal, plaster, stone, glass, ivory, etc.

Send 1s. for full details of this easy, fascinating and profitable hobby. Money refunded to bona fide enquirers.

**KARLENA ART STONE CO. LTD.**  
(Dept. PM2), 55, Deansgate Arcade, Deansgate, MANCHESTER, 3

Contractors to Education Authorities and many of the large industrial laboratories

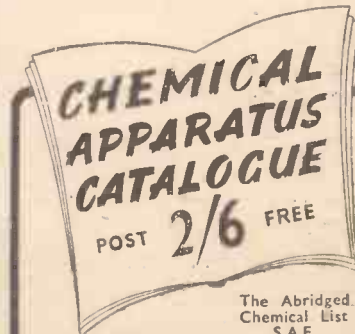

The Abridged Chemical List S.A.E.

**VICSONS LTD**  
148 PINNER RD, HARROW, MIDDLESEX.  
FOR ALL LABORATORY APPARATUS

**1951  
CHEMICAL  
PRICE  
LIST**

NOW-READY  
SEND STAMP

# M.O.S "EASY-TO-BUILD"

## Home Constructor Kits

### A.C. AMPLIFIER, TYPE A1

including pre-drilled chassis, pre-wired group-board, valves and all items including nuts, bolts, solder tags and solder. With Instruction Manual. For A.C. ONLY. 200-250 v. As previously £4.2.6 advertised.

INSTRUCTION MANUAL if purchased separately. (Contains full construction details) ... 3/6

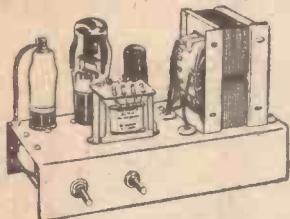

### A.C./D.C. AMPLIFIER, TYPE A2

The amplifier type A2 is based on the same fundamental design as the A1, but while the A1 can be used only on A.C. mains, the A2 may be used on A.C. or D.C. To those on A.C. the A1 is to be preferred since the safety factor is so much higher. Owing to the use of a transformer-less power supply the A2 amplifier is offered at a price which is extremely competitive, and places good equipment in a price range so far unheard of.

All the components of the A2 amplifier are tested and of first grade. Each kit is fully guaranteed.

The kit is supplied complete in every detail right down to nuts, bolts, solder tags and

solder. A pre-drilled chassis is supplied. A comprehensive instruction manual gives the fullest construction details, the instructions being written in such a way that those without previous knowledge can construct the A2 amplifier with the sure knowledge that it will operate, without trouble, from the time of first switching on. The instructions are supplemented with many clear diagrams. The circuit is simple and straightforward, but by the careful choice of component values the performance is outstanding. Primarily designed for crystal pick-ups, the amplifier can be used with magnetic pick-ups if desired. Output 2.5 to 3 watts. Complete kit with valves for A.C./D.C. Mains ... £2.19.6

Instruction Manual ONLY ... 3/-

HOME BROADCASTER MICROPHONE with matching transformer, mounted on desk stand ... 7/6

### RADIO FEEDER UNIT, TYPE RF1

Designed for use with the A1 amplifier in response to many requests, N.B.—Not suitable for use with the A2 amplifier. As with the A1 amplifier itself, simplicity, coupled with good performance, is the keynote. The tuning unit uses a "straight" TRF circuit tuning the Medium Wave Band only and the power to operate it is drawn from the A1 amplifier. If provided with its own power unit, it can be used with the A2 or any other amplifier.

Although a TRF circuit is employed, the unit is exceptionally sensitive: it can be used in areas of only moderate signal strength from the transmitter. Its selectivity, however, debars its use in areas of low signal strength.

By the use of a TRF circuit the bandpass is such that the output fed into the A1 amplifier is of very high fidelity, and full advantage can be taken of the transmitted quality.

The unit is provided with only two controls—Tuning and Sensitivity—and is very simple to operate. No tuning scale is provided as the great majority of constructors will prefer to fit the unit into a cabinet and so be able to choose an assembly to suit the housing. Adequate spindle length is provided in all cases.

As with other "easy-to-build" kits, the kit is complete in every detail, and the instruction manual fully detailed and illustrated.

\*Complete Kit, £2.5.0 Instruction Manual only, 2/-

HIRE PURCHASE TERMS ARE AVAILABLE ON ORDERS OF £10 OR OVER. Terms: one-third of total cash price as deposit. Balance, plus 10 per cent. interest, spread over six months to make six equal payments.

M.O.S MAIL ORDER SUPPLY CO., THE RADIO CENTRE, 33, Tottenham Court Road, London, W.1.

## Experimenters! Build the MATCHBOX RADIO SET

With the aid of our full instructions you can build a complete radio set in a matchbox, using parts purchased from your radio dealer.

Tuning arrangements include a medium wave inductor with station selector switch, and a long-wave coil for the B.B.C. Light Programme on 1,500 metres.

Demodulation is achieved by the use of a non-linear impedance unit of a new type, giving loud, clear reception.

This receiver works off a short indoor aerial in many districts, and being powered entirely by the incoming signal, requires no batteries.

Full step-by-step instructions, working drawings, and theoretical wiring diagram.

Price 3/- Post Free.

JOHN O'BEIRNE (P), 137, Cotham Brow, Bristol, 6. MAIL ORDER ONLY.

**FREE-**  
to  
purchasers  
of  
**MASON MASTER**  
**DRILLS**



This handsome wallet is given away with each of three sets of standard Mason Master Drills. Made of superior Rexine in a useful pocket size it provides a fitting storage for Mason Master Tungsten Carbide tipped drills—the drills which bore clean round holes in bricks, tiles, marble, rock and concrete. Also Glazemaster glass drills. Write for illustrated leaflet 'L'

JOHN M. PERKINS & SMITH LTD. Braunston, Near Rugby Phone: Braunston 238

OBTAINABLE FROM ALL GOOD TOOL STOCKISTS

**LOOK!** You Home Constructors!



# Wolf Cub

HOME CONSTRUCTOR KITS

- HAVE YOU EVER SEEN ANYTHING SO SIMPLE - SUCH VALUE FOR MONEY?



You buy a Wolf Cub Electric Drill for only £4. 19. 6

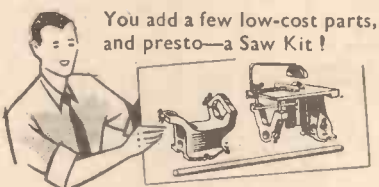

You add a few low-cost parts, and presto—a Saw Kit!

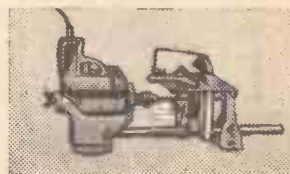

Add a few more—now it is a Lathe Kit!

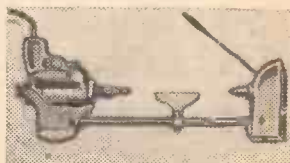

For a few shillings you have now a Drilling, Grinding and Polishing Kit!



- AND THAT'S NOT ALL THE STORY!

Write at once for large size, fascinating fully picturised folder. "Profitable Pleasure."

WOLF ELECTRIC TOOLS LTD., PIONEER WORKS, HANGER LANE, LONDON, W.5  
Branches: BIRMINGHAM, MANCHESTER, LEEDS, BRISTOL Telephone: PERVALE 5631-4.

# FREE!

to every ambitious engineer  
this valuable 176-page handbook!

# B

Better days lie ahead if you add "ENGINEERING OPPORTUNITIES" to your bookshelf. If you want to put yourself in line for quick promotion, higher pay and all that goes with it, as well as the sort of job you've always wanted, this enlightening guide to success—176 pages of vital, right up-to-date information—is your blue-print for a brighter future.

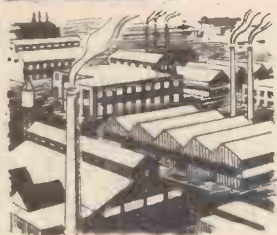

# I

In this book you will find out how to take advantage of to-day's opportunities; how you can rise to a position that ensures success, prosperity and security—the sort of job which, in Peace or War, Prosperity or Slump, makes you a "key" man on whom the craftsman or fighting-man is equally dependent.

# E

"ENGINEERING OPPORTUNITIES," besides showing how you can be helped to become a trained technician in your spare time, describes our unique Advisory and Employment Depts. Read about them and also about the superb range of Home Study Courses you can choose from... learn something of the methods that have already brought success to men in all branches of engineering throughout the world.

# T

# T

Thousands of B.I.E.T. Students—ordinary people with no special advantages except a real desire to succeed—have, under our guidance passed A.M.I.Mech.E., A.M.I.C.E., CITY & GUILDS and other major examinations. Because of our outstanding successes, you, too, can be confident of your success, under the guidance of B.I.E.T.



WRITE IF YOU PREFER NOT TO CUT PAGE

**POST THIS COUPON TODAY!**

Please send me a FREE copy of the latest 176-page edition of "ENGINEERING OPPORTUNITIES" IT IS UNDERSTOOD THAT NO REPRESENTATIVE WILL CALL ON ME

NAME .....  
ADDRESS .....  
.....  
.....

I am interested in.....  
(State subject, exam, or type of appointment that appeals to you.)

B. I. E. T. 410A SHAKESPEARE HOUSE,  
17-19, STRATFORD PLACE, LONDON, W.1.

Which  
of  
these  
is  
your  
Pet  
Subject?



### Mechanical Engineering

A.M.I.Mech.E.—CITY & GUILDS—General Mechanical Eng.—Maintenance Eng.—Diesel Eng.—Sheet Metal Work—Welding—Metallurgy—Machine Drawing & Design—Refrigeration, etc.

### Electrical Engineering

CITY & GUILDS—General Electrical Eng.—Installations—Illuminating Eng.—Electrical Science—Electricity Supply—Meters & Measuring Instruments—Mains Eng., etc.

### Radio & Television

A.M.Brit.I.R.E.—SERVICING CERTIFICATE—C. & G. Telecommunications—General Radio Eng.—Radio Servicing—Television Servicing—Sound Film Projection—Electronic Eng., etc.

### Production Engineering

A.M.I.P.E.—Works Management—Foremanship—Staff Supervision—Planning Eng.—Costing, etc.

### Automobile Engineering

A.M.I.M.I.—CITY & GUILDS—General Automobile Eng.—Automobile Repairs—High Speed Diesels—Garage Management, etc.

### Building & Civil Engineering

A.M.I.C.E.—F.R.I.C.S.—L.I.O.B.—General Building—Architectural Drawing—Sanitary Eng.—General Civil Eng.—Surveying—Specifications & Quantities—Heating & Ventilating—Painting & Decorating—Plumbing—Carpentry & Joinery—Timber Technology, etc.

PLASTICS—DRAUGHTSMANSHIP—AERONAUTICAL ENG.—FORESTRY

### SOME LETTERS AFTER YOUR NAME?

A.M.I.Mech.E. A.M.I.C.E. F.R.I.C.S. A.M.S.E. A.M.I.Struct.E. L.I.O.B. A.M.Brit.I.R.E. A.F.R.Ae.S. A.M.I.P.E. A.M.I.M.I.

HUNDREDS OF OTHER COURSES  
(Tell us what interests you)

**WE DEFINITELY GUARANTEE  
"NO PASS-NO FEE"**

We have printed "ENGINEERING OPPORTUNITIES" more than a hundred times and distributed over a million copies to ambitious men. Whatever your age, education or experience, if you are earning less than £12 a week; you really cannot afford to miss reading it. Send for your own copy to-day—FREE and without obligation.

**BRITISH INSTITUTE OF  
ENGINEERING TECHNOLOGY**

**THE B.I.E.T. IS THE LEADING INSTITUTE OF ITS KIND IN THE WORLD**



# PRACTICAL MECHANICS

EDITOR  
F. J. CAMM

APRIL, 1951  
VOL. XVIII. No. 208

Owing to the paper shortage "The Cyclist," "Practical Motorist," and "Home Movies" are temporarily incorporated.

## FAIR COMMENT

By The Editor

### PNEUMATIC GAUGING

**T**HE accurate gauging of the diameter of wires, the thickness of yarn and textile materials has been a problem which has not been satisfactorily solved until recently, when a new application of continuous pneumatic gauging to materials in motion during production was developed by the Metrology Section of the National Physical Laboratory, that famous national institution which has done such a vast amount of work in the realms of discovery, measurement and the solution of manufacturing problems.

Some of the finest brains in the country are employed in that famous establishment at Teddington. The new system employs a new principle of pneumatic gauging which has been in use in engineering for many years. The material being measured is passed through a measuring head to which compressed air is supplied. The material restricts the outlet of air, and the varying degrees of restriction as the material moves are reflected in variations of pressure in the pneumatic system.

These variations can be amplified when necessary and used to operate a recorder, so providing a permanent record of the fluctuations in size of the materials being measured.

In the manufacture of tyres rubberised cord is used, and this material comes off the calendaring rollers at about 180ft. per minute. It is 5ft. wide and impregnated with rubber in a tacky condition, which makes accurate measurement almost impossible. Variations in the thickness of the fabric can give rise to serious difficulties when the tyre is built up later, and so it is important to produce it of an accurately uniform thickness. No satisfactory method of measuring continuously the thickness of the tacky fabric had been discovered until this form of pneumatic gauging was tried.

A special type of pneumatic unit was designed for the job. The measuring head consists of two opposing jets, one above and one below the material. The material passes between the jets, and variations in its thickness cause variations in the pressure in the measuring head.

As in the original equipment for measuring fibres, these are magnified, and can be used not only to indicate on a meter the varying thickness of the material, but also to control the calendaring rollers so that unevenness can quickly be corrected. A measuring head was fixed at each edge of the rubberised fabric, and it was found that the method worked very satisfactorily. Without touching the material the equipment can measure and control its thickness to tolerances of less than one 3,000th of an inch.

### THE STORY OF SILICONES

**T**HE silicones are a new class of synthetic materials which occupy a position intermediate between plastics and the mineral silicates such as glass, mica and asbestos. They are available in many forms, including fluids with low viscosity change over a wide temperature range, greases, insulating resins, lubricants, and silicone rubber. All these materials are characterised by their temperature, stability, inertness, water-repellency, and excellent electrical properties.

Despite the notable research work of Professor Kipping, of Nottingham University, at the beginning of the century, silicones remained little more than a chemical curiosity until just before the recent war, when their industrial possibilities were appreciated in the United States, production difficulties overcome, and their manufacture undertaken there. The silicones' unique combination of properties quickly established them in a wide variety of industries, notably for electrical insulation operating at extremes of temperature, as insulating materials for sealing high-tension ignition systems, as damping and hydraulic fluids, high temperature lubricants, bonding agents, and protective coatings. Silastic rubber is flexible at -110 deg. F. and at 500 deg. F., and electric motors, for example, insulated with silicone resins and varnishes will give good service at 400 deg. F. and will withstand intermittent exposure to temperatures as high as 570 deg. F. It is thus possible to accomplish a greatly prolonged service life for machines operating under adverse conditions; ensure reduced fire hazards; greater freedom from overload failures; and increased output per unit weight.

The unusual characteristics of silicones are peculiarly adaptable to car polishes since, as will be seen, they are resistant to the effects of wide ranges of temperature, ranges indeed so wide that they would

never normally be met with under working conditions. They present a glass-hard surface resistant to all known elements and they produce a sheen rivalled only by glass. Thus a car polish based on silicones may be expected to produce a surface resistant to all known elements, hard enough to resist the attack of abrasive dust or dirt. Since silicones will not allow anything to stick to them, they will reject water, dust and dirt, enabling them to be wiped cleanly away with a soft cloth. The incorporation of silicones in car polish represents the most significant step forward in the motor industry in 25 years.

### "PRACTICAL ENGINEERING" DATA SHEETS

**T**HERE is a heavy demand for our companion journal "Practical Engineering," each issue of which contains eight Data Sheets dealing with machine design, and the principles of mechanical movements. Eight of these sheets are being given every week for at least thirteen weeks, and they cover most of the known mechanical principles.

The early sheets deal with the formulae and the laws which govern machine design, and later sheets give practical examples.

When complete they will form a valuable textbook of hitherto unpublished information on a subject on which information is extremely scarce. All those readers who followed my series on "Elements of Mechanics and Mechanisms" will find these Data Sheets of great interest, because they carry that series several stages further.

A special loose-leaf binder is available for 2s. 9d. "Practical Engineering" costs 4d. every Friday.

### A NEW EDITION

**T**HE fourth edition of "Newnes' Engineers' Reference Book," which costs 50s., or by post 50s. 10d., has just been published. This important book, which contains over 2,000 pages, has been enlarged in this edition by over 120 pages of new and hitherto unpublished matter. Mechanical, Civil, Structural, Automobile, and Aeronautical Engineers, Designers, Draughtsmen, Works Managers, Gauge and Toolmakers, Fitters and Turners, Foundry Workers, Diecasters, Milling, Planing, Grinding and Shaping Operatives, Wire Workers, Gear Cutters, Diesinkers, Heating and Ventilating Engineers, Costing and Production Engineers, Electroplaters, Welders, etc., will find this volume invaluable.—F. J. C.

#### SUBSCRIPTION RATES

including postage for one year

Inland - - - -	14s. per annum.
Abroad - - - -	14s. per annum.
Canada - - - -	13s. per annum.

Editorial and Advertisement Office: "Practical Mechanics," George Newnes, Ltd., Tower House, Southampton Street, Strand, W.C.2  
Phone: Temple Bar 4363

Telegrams: Newnes, Rand, London

Registered at the G.P.O. for transmission by Canadian Magazine Post.

Copyright in all drawings, photographs and articles published in "Practical Mechanics" is specially reserved throughout the countries signatory to the Berne Convention and the U.S.A. Reproductions or imitations of any of these are therefore expressly forbidden.

# Modern Gliders and Sailplanes

## A Review of Post-war British Machines

By J. C. REUSSNER

**T**HE revival of gliding in this country since the war has been very rapid, and reflects great credit on the enthusiasm and initiative shown by the devotees of this sport. The difficulties facing the clubs have been great; many of them had to restart their activities without either machines to fly or premises to accommodate them. Many of the machines owned by the clubs were requisitioned during the war, and these have had to be replaced at a price considerably higher than that received from the Government.

The cost of aircraft is a major obstacle in the way of the clubs, and this is particularly so in the case of new clubs. Before the war an intermediate glider of the Kirby Tutor type could be bought for about eighty pounds; to-day, the price is more than three hundred pounds. This rise in price is typical of all types of gliders and sailplanes. The increase is largely due to greater material and labour costs. Pre-war, good aircraft quality ply-wood could be bought for five-pence a square foot; to-day's price is nearer two shillings. Labour costs also have more than doubled.

### Smaller Machines

The increase in cost has reflected in the design of gliders developed since the war. The tendency in design has been to concentrate on simplicity of construction and generally to reduce the amount of expensive materials, such as plywood used in the airframe, to a minimum. That this has not resulted in any loss of progress is best shown by the fact that the most advanced British



*The Gull IV. This machine was specially designed for the British team to fly in the International contests held in Switzerland in 1948.*

### The Olympia Eon

Three different types of sailplanes, which can be classed as high-performance machines, have been developed since the war. These are the Olympia Eon, made by Elliotts, and the Gull IV and Type 34A, made by Slingsbys.

The Olympia is a development of the German D.F.S. Miese sailplane, which was originally designed for the gliding events in the Olympic Games of 1940. An international design contest was held for a standard sailplane to be flown by all competitors in these Games, and the Miese took first place. It is undoubtedly a first-rate aircraft, and is deservedly popular with many pilots. The Olympia has a span of fifteen metres, and is of the high wing arrangement. The pilot sits with his head just inside the leading edge of the wing, and the cockpit is covered with a "Perspex" bubble coupé. The original German machine had a fixed skid undercarriage, but in the later versions produced by Elliotts this has been supplemented by a landing wheel.

The Gull IV was specially designed for the 1948 International Gliding Contest held in Switzerland. Although only a few of these machines were made, they have been flown by some of Britain's leading pilots, many of whom have said it is the best fifteen-metre sailplane yet designed. The first prototype of this machine is now owned by the London Gliding Club, and several of their pilots have made "Gold C" flights in it.

The success obtained with the Gull IV encouraged its designers to further develop the type, and as a result the machine never went into full production. The outcome of this further development was the Slingsby Sky or Type 34A which flew last August.

The Type 34A, which is an 18-Metre span machine, can be said to mark the highest point yet reached in British sailplane design. From the test flights so far carried out it is apparent that its performance will be higher than any other production type sailplane yet made.

The 34A has been specially designed for contest flying, and incorporates several new features. In addition to the weight of the pilot and a full set of flying instruments 70lb. of equipment can be carried in the form of such things as radio and oxygen apparatus. The controls and structure are designed to operate with full efficiency at any height up to 40,000ft.; such heights as this are being attained by present day sailplane pilots.

The 34A has a gliding angle in the region of 1 in 30 and a minimum sinking speed of 2ft. per second. Flying alongside the German Weihe sailplane it has shown itself to be superior, the difference being especially noticeable at high speeds.



machines now have a gliding angle of 1 in 30, a gain of at least five points over the equivalent pre-war machine. The clubs, and to a large extent the export market, have been interested in the simpler utility machines which are suitable for intensive flying, and several new types have been produced to meet this demand.

There are, at the present time, only two firms in this country engaged on the production of sports gliders in any quantity. These firms are Elliotts of Newby, and Slingsby Sailplanes of Kirbymoorside. Several other firms have announced that they intend to make gliders, but, so far, none has appeared.

(Above) *The Sedbergh. This is the only two-seater to go into quantity production in this country since the war.*  
(Right) *Front view of the Slingsby "Sky" (Type 34A):*

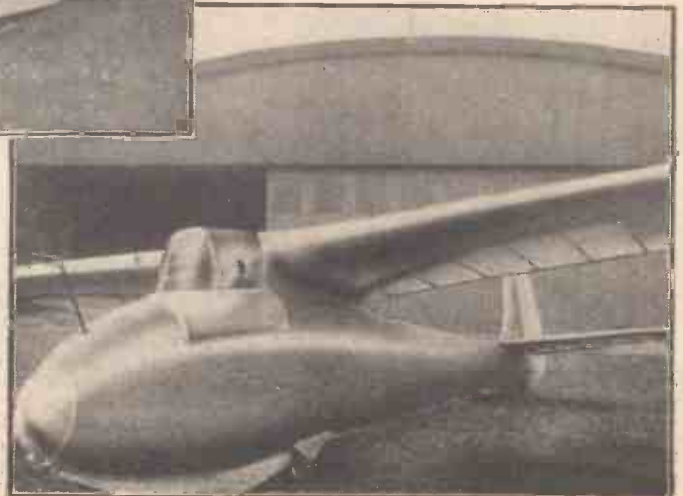

Providing sufficient funds are available, the 34A will form the standard equipment for British teams flying in future international contests. A machine of this type is to be on view at the Festival of Britain Exhibition.

machine of the same name. Its performance is not very high, but it is a robust machine capable of standing a lot of rough handling, and for this reason it has long found favour with the clubs.

A small number of these primaries have been ordered by the Air Ministry and are to be issued to the Combined Cadet Force units for glider training purposes. They will principally be issued to units at large schools whose members are unable to attend the regular Home Command gliding schools.

The Kirby Cadet is basically a pre-war design and, with the exception of the lower performance wing, it is identical to the Tutor. The Kirby Cadet was the first type to be adopted by the A.T.C. when they took up gliding during the war, and, at the present time, several hundred of this type are still in service.

**Two-seater Machines**

The idea of using two-seater gliders of medium performance to train newcomers to gliding has found increasing favour since the war, but here again the obstacle has been the cost.

There have been several experimental two-seater gliders designed since the war, but only one has gone into quantity production. This is the Sedbergh, produced by Slingsby Sailplanes. The machine is a high wing monoplane of 54ft. span, and an all-up weight of 1,050 lbs. It was designed for both elementary and advanced training, and its side-by-side seating arrangement makes it ideal for this purpose. The Sedbergh has been a marked success, most of the leading clubs in the country own one, and it has been adopted by the R.A.F. as their standard two-seater training glider.

The introduction of the Sedbergh glider has, to a large extent, altered the initial training methods of the clubs that possess them. In place of the old method of ground sliding in a single-seater, the pupil is now taken up in a two-seater with an instructor; this gives him a far better idea of the controls and results in far less hair-raising crashes.

Another two-seater which is attracting considerable interest at the present time is the Two-Seater Tutor. This machine is essentially a two-seater version of the stan-

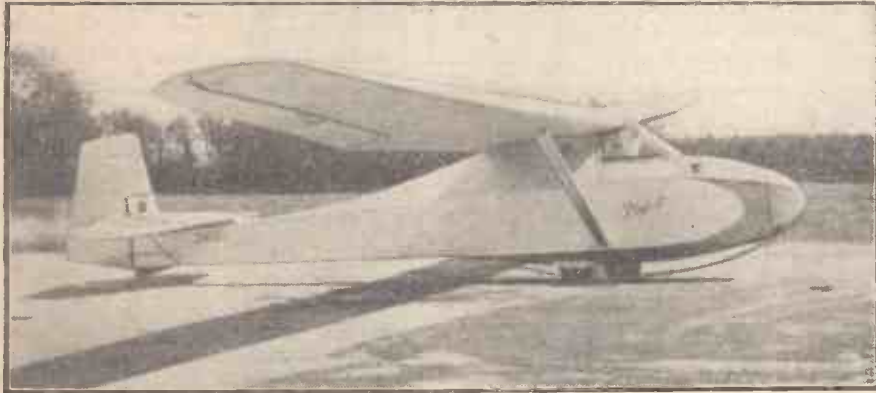

*The Prefect Intermediate Sailplane. Although the type has only been in production for a short time it is rapidly proving to be an ideal club machine for training pilots to fly the advanced performance sailplanes.*

**Intermediate-type Sailplanes**

Three intermediate-type sailplanes are at present in production in this country. These are the Baby Eon, the Kirby Prefect, and the Kirby Tutor. The first is made by Elliots, and the other two by Slingsbys.

The Baby Eon is a development of the German Grunau Baby II B. The Grunau is probably the most popular intermediate sailplane in the world. It has been produced in its various forms in countries as far apart as Germany and Japan. The Baby Eon has several improvements over the standard Grunau; a main landing wheel has been introduced, the fuselage nose has been re-designed, and the cockpit has been altered to make it more comfortable.

The Kirby Prefect is an entirely new design that has been developed in the last two years. Its airframe has been designed to suit present-day conditions; the rear fuselage and most of the wing are fabric covered, thus making a saving in the cost and weight of plywood. The Prefect has received high praise from the pilots that have flown it. Its high stability and good handling qualities make the machine ideal for soaring in thermals and clouds. One point on this type, which is particularly interesting, is the dive brake. This was specially designed to fit into the limited space available in the wing. The brakes are aerodynamically balanced so that the manual operating load in the cockpit does not vary with the speed of the aircraft. They are just as light to operate at a speed of thirty miles an hour as at a hundred.

The third intermediate glider, the Kirby Tutor, is developed from the pre-war

The Tutor, under the name of Cadet II, is one of the standard types used by the R.A.F. for teaching the boys of the Air Training Corps to glide. Well over a hundred of these aircraft are in service with the R.A.F.

Elementary training in single-seater gliders is largely going out of favour in this country, but there are still two types of elementary training gliders in production at the present time. These are the Primary Eon and the Kirby Cadet.

The Primary Eon is an open Primary of the old type. The machine is of very rugged construction and is specially designed to withstand the heavy landings encountered in elementary training. The construction and controls are of the simplest possible type; the whole accent of design is on ease of handling and repair, rather than performance.



*(Above) The Tutor two-seater. This machine has been evolved to try and provide a cheap training machine for clubs. (Left) A side view of the Slingsby "Sky" (34A).*

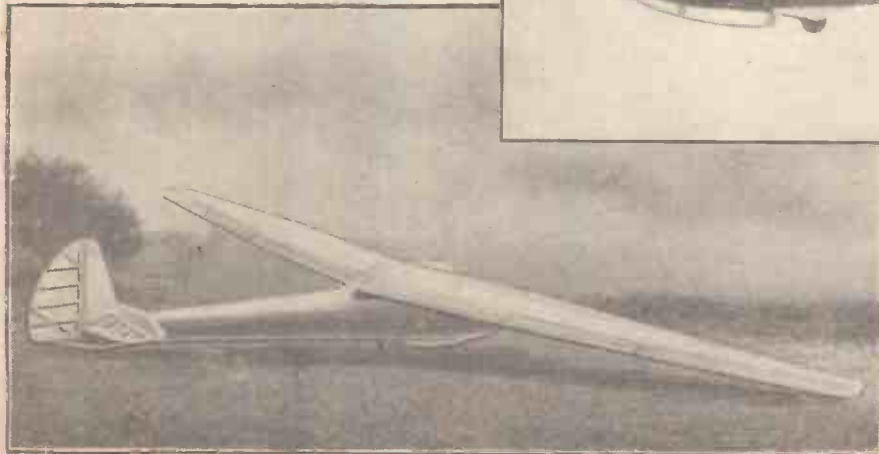

dard Tutor, and uses the same wings and tail unit as that machine. This two-seater is intended as an inexpensive training machine for club use, and as such is fulfilling a useful role. In addition to the complete aircraft, the makers are marketing kits of parts for assembly in amateur workshops. Aircraft of this type have already been supplied to several countries abroad, including India,

Australia, New Zealand and South Africa. The performance of the Tandem Tutor is only slightly below that of its single-seater counterpart; this fact makes it considerably easier for the trainee pilot to proceed from his two-seater training to his first flight in a solo machine.

entries sent in had to be complete. Assembly drawings of all the components were required, together with full strength and performance calculations in the form of a typed record, all of which involved a great deal of work for the entrants. Sufficient funds have now become available to allow

aileron droop adjustment, which allowed higher lift to be obtained from the wings when flying at low speed, and the neat and unobtrusive centre landing wheel under-carriage. The Nimbus never went into quantity production, but the prototype was flown by many pilots and favourable com-

TABLE OF SAILPLANE AND GLIDER TYPES AND THEIR CHARACTERISTICS

Name	Maker	Span	Length	Wing Area Sq. ft.	Wt. Empty Lbs.	Load Lbs.	Best Gliding Angle	Minimum Sinking Speed F.P.S.	Remarks
<b>HIGH PERFORMANCE</b>									
Olympia Eon	Elliotts of Newbury	15 m.	23ft. 10in.	161	410	210	25 to 1	2.2	Cantilever Wing.
Gull IV	Slingsby Sailplanes	15 m.	23ft. 10in.	156	467	250	25.5 to 1	2.4	Cantilever Wing.
Sky	Slingsby Sailplanes	18 m.	24ft. 10in.	186	535	265	30 to 1	2	Cantilever Wing.
<b>INTERMEDIATE</b>									
Baby Eon	Elliotts	44ft. 5in.	19ft. 11in.	153	340	210	17 to 1	2.78	Strutted Wing.
Kirby Prefect	Slingsbys	45 ft.	20ft. 8in.	156	364	240	21 to 1	2.7	Strutted Wing.
Kirby Tutor	Slingsbys	43ft. 4in.	21ft.	170	340	200	17 to 1	2.9	Double Strutted Wing.
<b>ELEMENTARY</b>									
Primary Eon	Elliotts	34ft. 2in.	20ft. 7in.	172	264	200	10 to 1	4.25	Wire Braced.
Kirby Cadet	Slingsbys	38ft. 6in.	20ft. 11in.	170	297	210	15 to 1	3.5	Double Strutted Wing.
<b>TWO-SEATERS</b>									
Nimbus	Short Bros.	62ft.	27ft. 4in.	240	800	450	25.4 to 1	2.3	Low Wing Cantilever.
Sedbergh	Slingsbys	54ft.	26ft. 8in.	260	600	450	21 to 1	2.8	Strutted Wing.
Two-Seater Tutor	Slingsbys	43ft. 5in.	20ft. 11in.	170	380	450	16 to 1	3.7	Double Strutted Wing.

An event which took place in 1947, which is of particular interest, was the British Gliding Association's two-seater design contest. The contest was for a high performance two-seater of 60ft. span, designed to a specification laid down by the B.G.A. Over 30 entries were sent in from this country and various parts of the Empire, and from these the best six were chosen. The contest was of a high standard and the

the winning entry to be built, and the prototype is now under construction at F. G. Miles's factory.

An interesting two-seater sailplane was developed by Short Brothers, the famous flying-boat builders. This aircraft was called the Nimbus and it had several novel features, the most noticeable of which was its low wing arrangement. Other points of interest were the long, one-piece moulded coupé, the

ment on its performance was received.

Since the war, the trend in British glider design has been towards more simple machines that can be produced at the lowest possible cost. It is probable that this trend will continue and that any new machines which appear in the next few years will be small utility types which have been developed to give the greatest efficiency possible for their size.

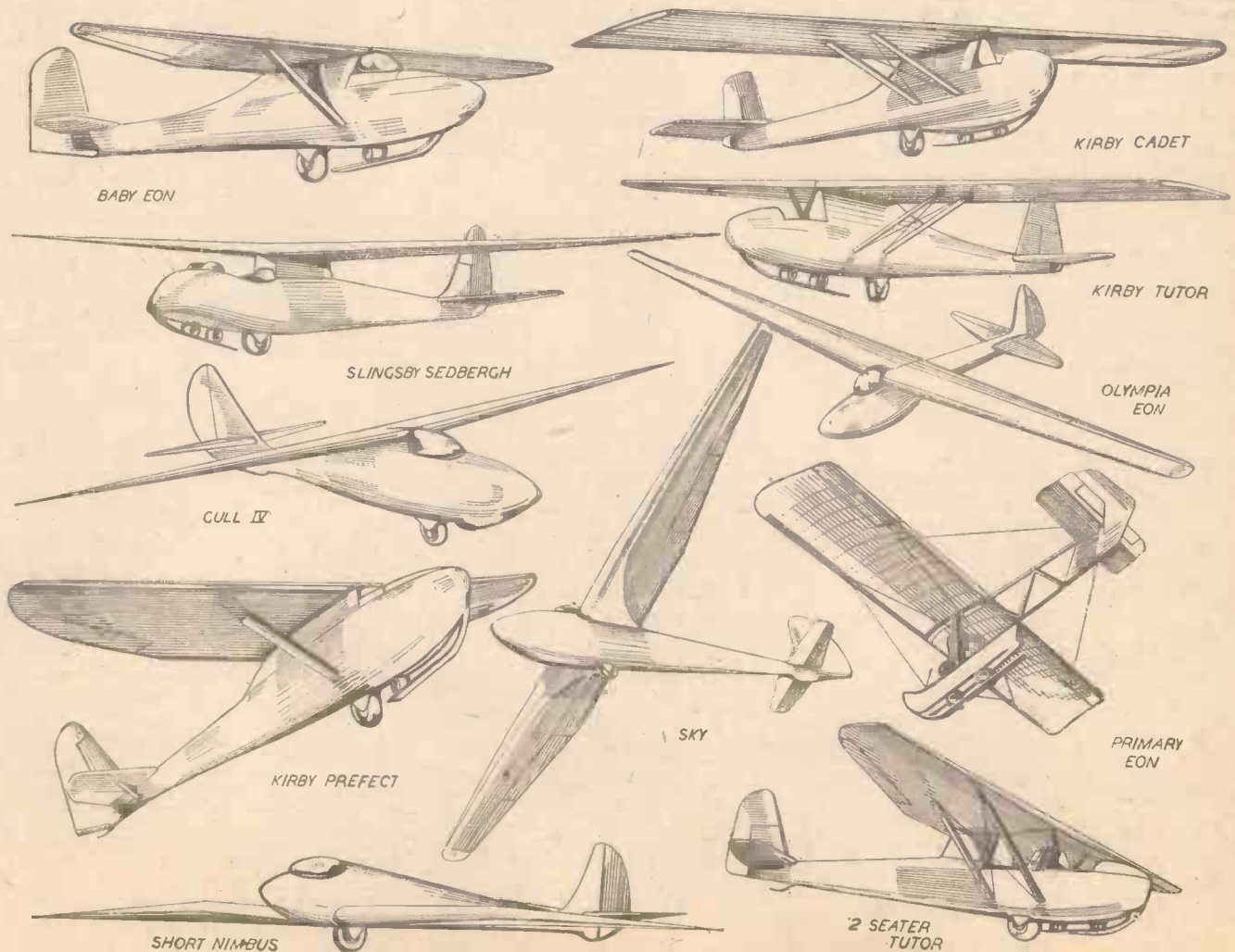

A Group of Modern British Sailplanes and Gliders.

# Making an Electronic Alarm Unit

Constructional Details of a Useful Unit for Domestic Use

By G. SYMONDS



The completed alarm unit with casing removed.

QUITE a number of baby-alarms are at present advertised in various journals and newspapers, but they appear to take the form of either a normal microphone-amplifier-loudspeaker arrangement, or are designed to connect to a radio receiver in such a way that the baby's cries can be heard over and above the programme. The latter arrangement is most undesirable, since it assumes that the "baby-sitter" is continually listening to the radio.

The unit to be described differs in that it gives warning by means of a bell or buzzer (whichever is preferred) only when the volume of sound emanating from the restless youngster rises above a predetermined level.

## Circuit

As can be seen from Fig 1, comparatively few components are needed. They can be readily and cheaply obtained from advertisers in this journal, but it is felt that most constructors will have a number of parts which they will wish to utilise. It is for this reason, bearing in mind the variations in size of components, that no dimensions for the chassis have been given.

Starting at the microphone the operation is as follows: The output from the carbon mike, used for maximum sensitivity, is stepped up by the 100:1 ratio transformer, and is further amplified by V1. V2 receives the amplified signals, conducts only on the positive half-cycles and charges C4 in the positive direction. V3 is normally biased back by R8 to such an extent that the anode current is just insufficient to hold the relay closed, but the arrival of a positive charge on C4 reduces the bias thus increasing the anode current sufficiently to

operate the relay and switch on the warning device. After the sound input has ceased there is a time delay of a second or so before the alarm stops ringing, this being due to the time taken for C4 to discharge through R7 restoring the normal bias on V3. A longer or shorter delay can be obtained by substituting a different value for R7.

The polarising voltage for the microphone is provided from the H.T. supply by R1

LIST OF COMPONENTS	
<b>RESISTORS</b>	<b>CAPACITORS</b>
R1. 1k. $\Omega$ . 5 w.	C1. 50 $\mu$ F. 25 v.
R2. 25k. $\Omega$ . 3 w.	C2. .1 $\mu$ F. 350 v.
R3. 50k. $\Omega$ . 5 w.	C3. .25 $\mu$ F. 350 v.
R4. 150 $\Omega$ . 25 w.	C4. .1 $\mu$ F. 350 v.
R5. 22 m $\Omega$ . 5 w.	C5. 50 $\mu$ F. 25 v.
R6. 1 m $\Omega$ . 25 w.	C6, C7. 8-8 $\mu$ F. 450 v.
R7. 5 m $\Omega$ . 25 w.	C8. .1 $\mu$ F. 350 v.
R8. (See text.)	
<b>VALVES</b>	
V1, V3. V.R.65 (SP61).	
V2. NR.54 (EB34)	
<b>MISCELLANEOUS</b>	
T1. 100 : 1 microphone transformer.	
T2. Mains transformer. (See circuit diagram or text.)	
CH. 10. H midget choke. (See text.)	
Rectifier. 250 v. 30 mA. half-wave, Selenium.	
Microphone. G.P.O. type carbon.	
6-v. bell or buzzer, as preferred.	
Relay. (See text.)	
S.W. S.P.S.T. Bulgin.	

and R2, R1 being included merely to prevent the decoupling capacitor, C1, being ruined in the event of the microphone being disconnected with the unit switched on.

The 100:1 ratio transformer was chosen in the interest of sensitivity. It is really intended for use with a moving-coil microphone, but as quality is of no importance it is desirable to get as much voltage gain here as possible. A further slight increase in amplification can be obtained from V1 by providing R4 with a 50 mf. by-pass capacitor, but as the overall sensitivity was found to be quite adequate, its inclusion did not seem justified.

C8 is included to absorb the back E.M.F. impulses which occur each time the coil of the bell or buzzer is switched off. These, it was found, without C8, are stepped up by the mains transformer and introduce a pulse into the H.T. line of sufficient magnitude to re-operate V3.

## H.T. Current

In the quiescent state the H.T. current required by the unit is in the order of 15 mA. and rises to about 20 mA. on the arrival of a sound input to the microphone. The mains transformer, however, as is usual with half-wave rectification, must be capable of supplying twice this amount. No provision has been made for the extra L.T. current required by the alarm bell, as it is only expected to be drawn from the transformer for very short and infrequent periods.

## Relay

The relays used by constructors are likely to be the most widely differing components used, as a great variety of shapes and sizes are available. Any relay will do, providing it does not require more than 10 mA. for positive operation. Of a number of ex-Government relays tested for suitability, it was found that those of about 1,000 ohms resistance and over required downwards of 8 mA. The one shown in the photograph was rewound with very fine wire to a resistance of 2,000 ohms, and opens and closes at 4 mA. and 6 mA. respectively.

## Construction

The general layout of components can be seen in the photograph, the only important points being to mount the mains transformer and microphone transformer as far apart as possible, and with the centre limbs of the cores at right-angles to each other to prevent pick-up of A.C., which might be sufficient to operate the unit.

No. 20 S.W.G. aluminium sheet will be found quite suitable for the chassis and cover, and is very easy to work.

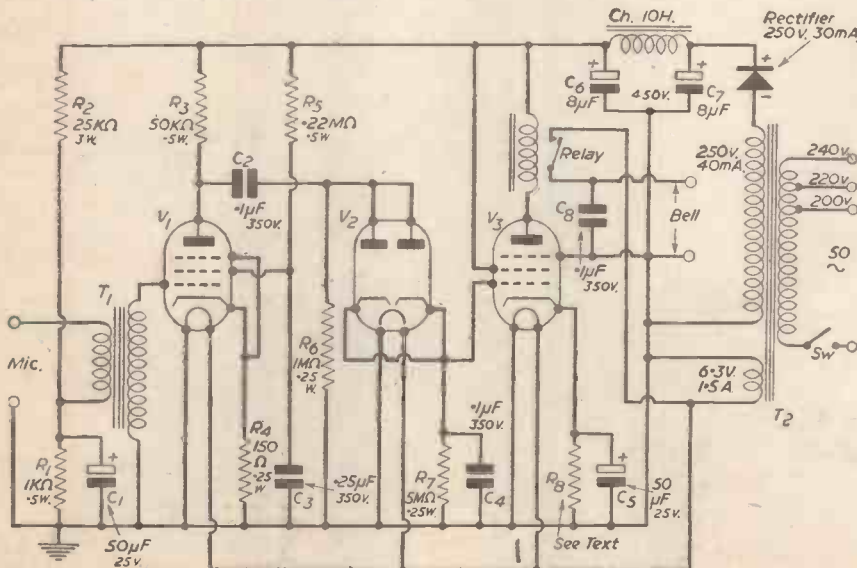

Fig. 1.—Theoretical circuit diagram.

**Adjustment**

The value of resistor R8 will depend on the relay used, and the best way of ascertaining this is to connect in its place a 2,000 ohms variable resistor. Starting at maximum, the value should be decreased until the relay just closes and then increased to the point where it opens again. A fixed resistor of the same value as that left in circuit should now be connected in place of the variable resistor. The unit will now be set at its maximum sensitivity, and it will be found quite adequate for the intended purpose.

Imaginative constructors, who find other uses for the unit, may prefer to include a sensitivity control. A convenient method of doing this is to include a 2,000-ohm variable resistor in series with R8, thus enabling the hold-off bias on V3 to be varied, and causing C4 to require a greater charge before the relay is operated.

**Transformer and Choke**

The specifications for the mains transformer and smoothing choke are given in the components list, and no difficulty should be experienced in obtaining suitable types, but for those constructors who wish to make these, suitable core sizes are given in the table in Fig. 2. Both are commonly used for output transformers, so a search through the junk box will probably prove fruitful. The dimensions given in the table need not be adhered to strictly, especially in the case of the choke, but the mains transformer dimensions are definitely the smallest permissible, it being found just possible to get the required number of turns on by careful winding. A constructor inexperienced in winding transformers, would probably do well to choose a core having a centre limb with a larger cross-sectional area, or a larger window area, or both.

If a larger cross-sectional area is used, the number of turns per volt required for each winding for 50 c/s mains can be calculated from the formula:— $T = \frac{8}{A}$ , where T=turns per volt, and A=the cross-sectional area in sq. ins. 10 per cent. more turns

must then be added to both secondaries to allow for losses.

**Windings**

When the cores to be used have been chosen, stout cardboard bobbins should be made to fit them, and given two coats of shellac varnish and allowed to dry thoroughly. The choke, being the least critical, is best wound first to enable experience to be gained in winding evenly, and should have its bobbin filled to capacity with No. 40 S.W.G. enamelled wire. This will be found to have a resistance of about 1,000 ohms. As 40-gauge wire is too fine to use for connections, three or four inches of 30 S.W.G. wire, or Litz, should be soldered to the ends of the winding, and brought out through holes previously drilled through the cheeks of the bobbin. The connections may

be insulated by folding a piece of waxed paper over the join.

The mains transformer may now be wound. If the core size given in the table is used, the number of turns required for the primary (which should be wound first), will be 1,840, 2,024 and 2,208 for 200 v., 220 v. and 240 v. respectively. Alternatively, if the mains voltage on which the unit is to be used is known the primary may be wound for this voltage only and the tapplings dispensed with. Number 36 S.W.G. enamelled

wire is needed. It is not necessary to interleave each layer, as is usual in mains transformer construction, but merely to include a single turn of waxed paper at about every 500 turns. Having wound the primary, it should be insulated from succeeding windings by several turns of waxed paper, or empire tape. This should be cut slightly wider than the bobbin so that the edges curl up and prevent turns of the secondary winding slipping down and becoming mixed up with the primary. The H.T. secondary needs 2,475 turns of 40 S.W.G. enamelled wire, the ends being brought out as for the choke. For the L.T. winding, 65 turns of 24 S.W.G. enamelled wire are needed, wound double. The reason being, it is much easier to manipulate two strands of 24 S.W.G. wire than a single strand of 20 S.W.G. which would otherwise be needed.

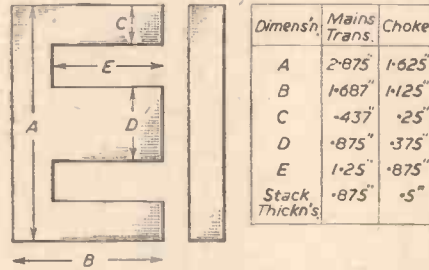

Fig. 2.—Details of suitable cores for the mains transformer and choke.

**Waxing**

After completing both transformer and choke, but before assembling the cores, any moisture must be driven out of the windings by placing the bobbins for an hour or so in a warm oven. Immediately they are removed, they should be immersed in molten wax (bees-wax is quite suitable), removed, and allowed to cool. This will leave a casing of wax around the bobbin thus preventing any further ingress of moisture. When assembling the cores the E and I sections should be interleaved in the mains transformer, but in the choke they should be assembled all the same way round. If a coil winder is not available, a convenient method of winding and counting the number of turns is to use a geared hand-drill cramped to the bench, with the bobbin to be wound mounted on a spindle held in the drill chuck. The number of turns of the handle can easily be counted and a note made of each 100 turns. To obtain the number of revolutions of the handle required, the turns, needed on the bobbin should be multiplied by the number of teeth on the small gear wheel, divided by the number on the large wheel.

**Items of Interest**

**New Wheel-making Plant**

THE manufacture of railway wheels at the Trafford Park Works of Taylor Bros. and Co., Ltd., is being transferred to a new plant constructed as part of the steel industry's development plan. This plant, said to be the most modern of its kind in the world, will manufacture forged and rolled steel solid wheels and disc centres at a continuous rate of sixty per hour. With the new equipment wheels will be produced within close tolerances so that subsequent machining may be reduced to a minimum.

**The Latest All-purpose Helicopter**

ACCORDING to a recent announcement the Westland Aircraft Company, of Yeovil, are to construct in England the latest type of Sikorsky helicopter, known as the "S.55." This remarkable aircraft can be adapted for many uses in peace and war. With modifications of the internal arrangements it can be employed as a passenger-freight carrier, as a flying ambulance, and as a troop carrier with accommodation for ten men. An important feature of the helicopter is the powerful hoist, by means of which people can be raised from the ground to the aircraft when the nature of the ground makes a landing impossible. When at sea the machine can carry out many duties, such as observing for naval gunnery, submarine

hunting, and ship to shore transport. At first, the British-built "S.55" will be powered by American 600 h.p. Pratt and Whitney Wasp engines, but British engines will probably be used later. The three-bladed main rotor has a diameter of 53ft. Dual controls are fitted, and the normal fuel capacity is sufficient for a range of about 400 miles. The aircraft has a maximum speed of 110 m.p.h. and can cruise at 86 m.p.h. at 1,000ft. It can climb at a rate of about 1,000ft. per minute.

In Korea the "S.51," an earlier type of helicopter, has been used in large numbers by U.N. forces.



A fine example of precision modelling. Built to a scale of 1in. to 1ft., this model of a twin Bofors 44 mm. gun, made by J. B. Glossop and A. D. Trollope, was exhibited at the Model Engineering Exhibition held at the Horticultural Hall, Westminster, last year.

# Building Aluminium Boats—2

With Notes on Design

By G. F. WALLACE, A.F.R.Ae.S.

**I**N general the material for a single chine (see Fig. 8a) must be at least one gauge thicker than the plating, whereas the material for a double chine can be of the same thickness as the plating. Only a soft material that does not rapidly work harden is suitable for the manufacture of chine angles, and this practically limits the choice to soft commercially-pure aluminium sheet. The chine is formed by beating it to shape on a wooden former, as illustrated in Fig. 9. In plan, the former is shaped to the curvature

(Continued from page 159, March issue)

it springs away and does not exactly conform to the curvature of the former. On assembly the chine can usually be clamped to the correct shape again on the hull, but this difficulty can also be overcome by increasing the curvature of the former to allow for the spring. As the increase to be made varies with the thickness, curvature and hardness of the material, this method is not recommended for the amateur. If the curves of

angle except that its angle is the complement of the chine angle. Only the single type of construction is used for the gunwale, which joins the deck to the sides in the same way as the chine angle joins the bottom to the sides. There are two types of well construction, as shown in Fig. 11. If the inboard edge of the well is a straight line, the edge of the deck can be turned over to form the longitudinal stiffening, as shown in Fig. 11a. If the inboard edge is curved, a separate stiffening angle must be used, as shown in

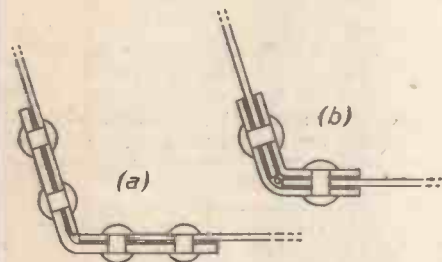

Fig. 8.—A single and a double chine.

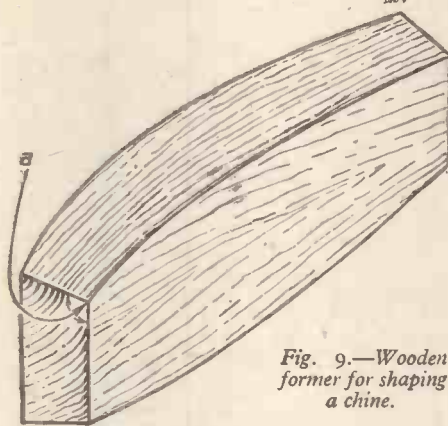

Fig. 9.—Wooden former for shaping a chine.

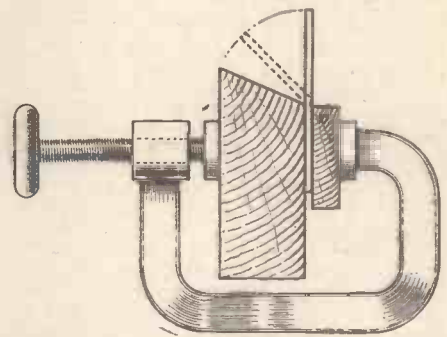

Fig. 10.—Using a clamp for holding the former and aluminium strip for shaping a chine.

of the sides and in elevation to the curvature of the bottom, the angle "a" is the angle between sides and bottom. The chine is formed by first cutting a strip equal in width to the two sides of the chine angle. This strip is laid on the former so that half the width projects over the edge and the remaining half is clamped on to the former by a clamping bar and "G" clamps, as shown in Fig. 10. The free edge is now beaten down with a wooden mallet until it conforms to the other face of the former. Even with soft aluminium there is a certain amount of spring and it will be found that when the chine angle is taken off the former

the boat are arcs of circles all that is needed is a short length of former, say, 2-3 feet, for each arc, and the chine can be formed up progressively. If the curves are not arcs of circles a series of formers totalling the entire length of the boat will be required.

### Decked Boats

In the case of decked boats the gunwale angle is made in the same way as the chine

Fig. 11b. This can usually be made from the same angle as used for the frames. In an open boat, the gunwale can be made as a version of the well deck shown in Fig. 11b, or the same angle as used for the frames can be used as shown in Fig. 11c. This is only suitable for small boats. As the angle usually faces outwards, as shown, it serves as a rubbing strip as well. There is one other method of making chines which, although not recommended for the ordinary

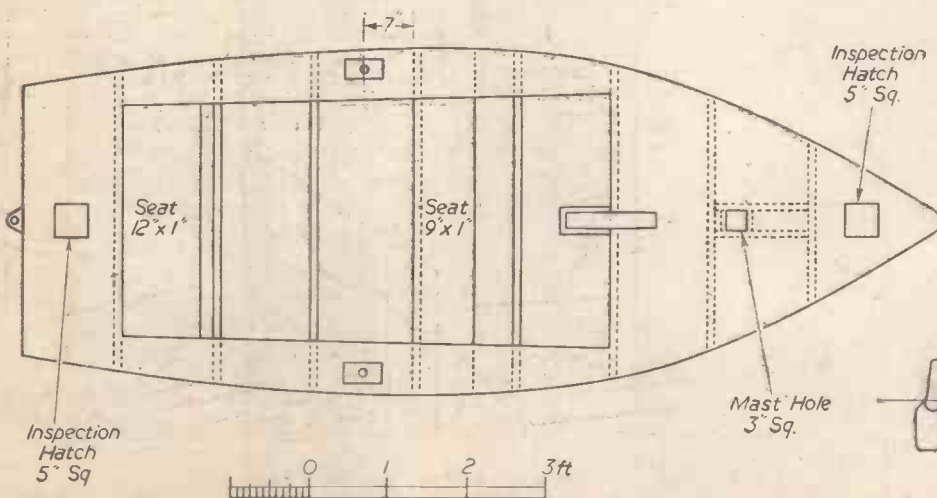
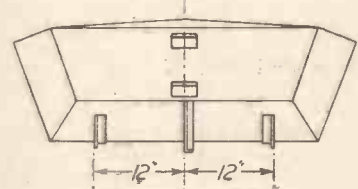
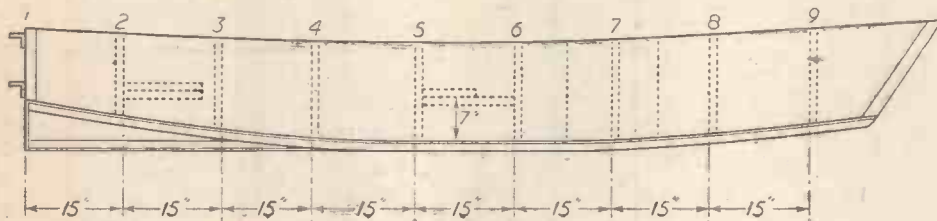

Inspection Hatch 5' Sq.

Seat 12' x 1'

Seat 9' x 1'

Mast Hole 3' Sq.

Inspection Hatch 5' Sq.

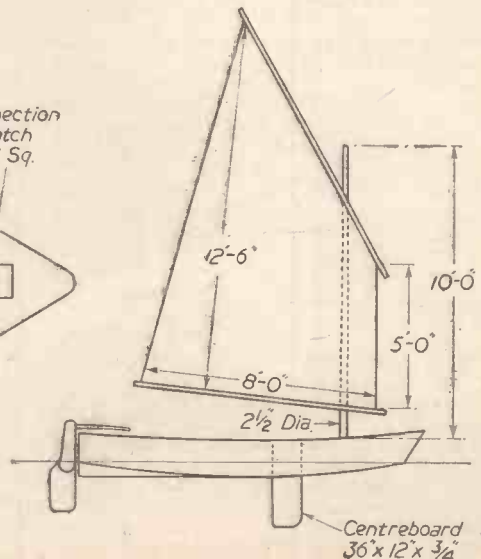

Side and rear elevations and plan of a 12ft. aluminium dinghy, with a profile of the completed boat.

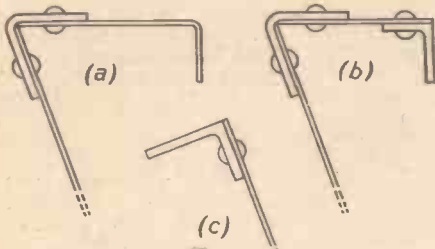

Fig. 11.—Three types of gunwale.

amateur, may be of interest to anyone who could make up the necessary tools. This is to use an extruded section and form it to shape by means of a set of rolls. The advantage of this method is that it enables a thicker chine angle to be used and would be particularly suitable for the larger boats. The angle is bent by passing it through rolls, as shown in Fig. 12. The two lower rolls "a" are fixed, but the upper one "b" can be moved up and down by the screw "c." The angle is placed in the rolls at one end, as shown, and the roll "b" screwed down

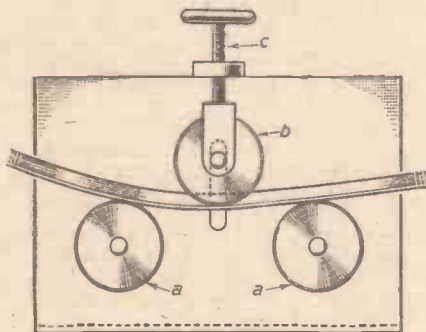

Fig. 12.—Method of using rolls for bending chines.

so that the angle is slightly bent between rolls "a." By moving the section backwards and forwards through the rolls a curve is imparted to the whole length of the angle. This curve can be increased progressively by gradually screwing down roll "b."

**Fittings and Details**

The first thing to remember about fittings is that because the main construction of the boat is aluminium it does not follow that all fittings must be of aluminium. There is no sense, for instance, in providing aluminium seats or an aluminium tiller. Another point is that some fittings require very small quantities of special sizes of aluminium rod, bar, or sheet, and it may be more economical

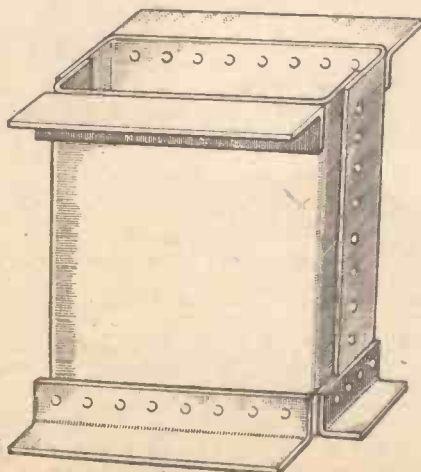

Fig. 15.—Showing the construction of a centre-board trunk.

to use some more easily obtained material. It is also important in the design of the boat to utilise the plating and frame angle material as far as possible in the construction of fittings.

As regards timber, on no account must oak be used if it comes in contact with aluminium. Mahogany, ash and pine or fir are satisfactory, but if wood and aluminium are in permanent contact the mating surfaces must be painted with bitumen paint and assembled wet. The following are the woods recommended for various uses.

Builder's deal for floorboards. Mahogany for seats, rudder and centre-board. If mahogany cannot be obtained, builder's deal can be used for seats and centre-board.

On no account must brass or any other copper-rich metal be used on aluminium boats; cast-iron and mild-steel fittings are satisfactory providing they are heavily galvanised and a bitumen paint used between mating surfaces. Various fittings and details will now be considered in more detail.

**Centre Boards**

For boats of 14ft. length or under, the dagger type centre board is recommended.

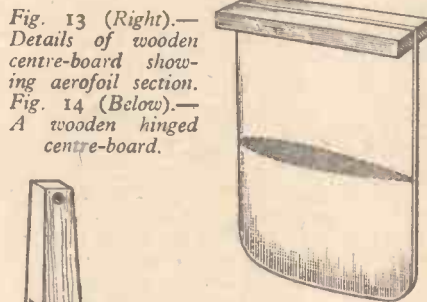

Fig. 13 (Right).—Details of wooden centre-board showing aerofoil section. Fig. 14 (Below).—A wooden hinged centre-board.

In particular, it gives a much smaller and easier centre board trunk. The centre-board should be made of wood and shaped to an aerofoil section over the submerged section, as shown in Fig. 13. It should be weighted so that it just floats when fully down. This makes it very easy to raise and lower. The hinged type of centre-board can be made of wood or 3/16in. thick aluminium, although wood is recommended as it is easier to obtain. The construction of a wooden hinged centre-board is shown in Fig. 14; this type of board must also be weighted. Fig. 15 shows the construction of the centre-board trunk for a dagger-type centre-board. The

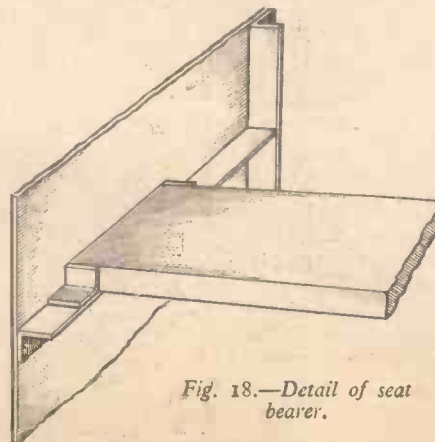

Fig. 18.—Detail of seat bearer.

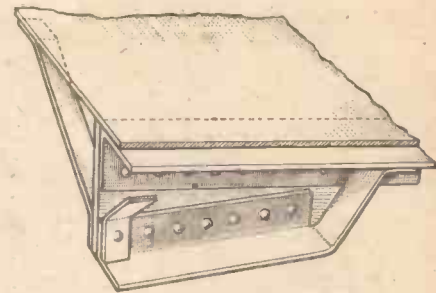

Fig. 16.—Part sectional view showing the construction of an aluminium skeg.

construction of trunks for hinged centre-boards is similar, except that they are larger and have a hinge pin in addition.

**Skegs and Keel**

No keel in the ordinary sense is needed in an aluminium boat, and its place is taken by the centre one of the longitudinal stiffening angles. Skegs can be made of the same material as the sides and bottom, suitably

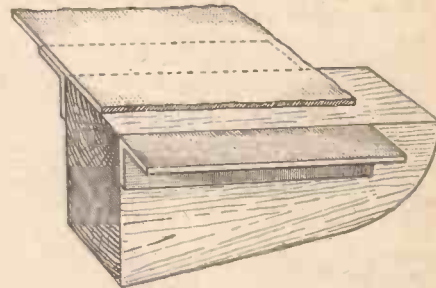

Fig. 17.—Details of a wooden skeg.

stiffened by angle; or can be made of wood. A wooden skeg can usually be made stiffer, but only a good quality, well-seasoned wood should be used, preferably mahogany or pitch-pine. Fig. 16 shows the construction of an aluminium skeg and Fig. 17 shows the construction of a wooden skeg. If a keel is required, it can be made by extending the skeg the length of the boat.

**Seats**

In a boat of the decked and well type of construction, the seats are best made of loose planks, resting on seat bearers formed of frame angle, as shown in Fig. 18. Even if the seat is not the same width as the distance between frames, the bearers should be carried from frame to frame as shown. If the boat is of the completely open type with the gunwale formed by a single piece of angle, the seats are required to contribute to the stiffness of the hull and should be made as shown in Fig. 19. The wooden seat (a) is secured to the two angles (b) which are permanently riveted to the hull at each end.

(To be continued)

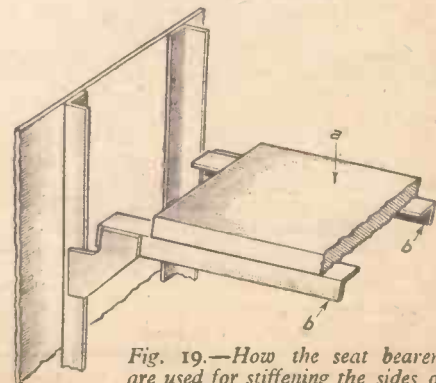

Fig. 19.—How the seat bearers are used for stiffening the sides of a completely open type of boat.



18th Article of a New Series

# MODEL ENGINEERING PRACTICE

by F. J. Camm

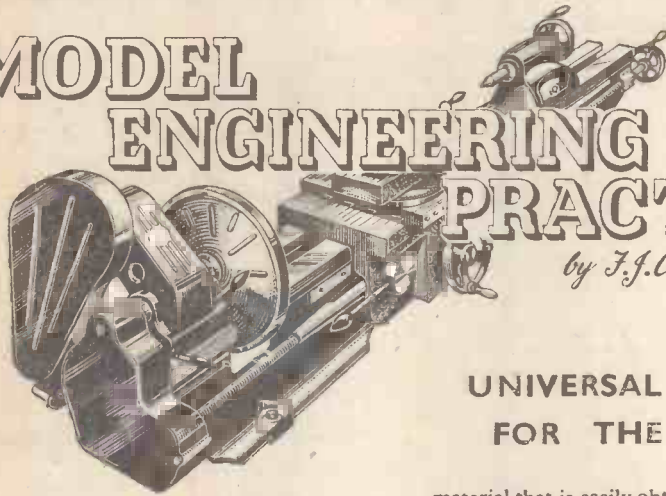

## UNIVERSAL HOLDER FOR THE LATHE

**M**AKE sure that the thread fits easily. Being satisfied about this, bore the register about 1/16in. deeper than the length of the plain portion, so that the plug previously made is a good push-fit in the hole. Slightly radius the sharp corner at the front edge.

The remainder of the machining is carried out with the part screwed on in position, machining the front so that the face is just proud of the end of the spindle. Measure the depth of the register in the back of the chuck and turn a short spigot on the face of the casting to fit this closely, seeing that it is clear of the bottom by 1/32in. Turn the outside diameter of the flange, and if it is necessary to reduce the thickness reverse the adaptor, placing a distance piece on the nose to take up the plain portion. Except for drilling, the adaptor is complete. Mark an accurate pitch circle for the bolt holes with the point of a screw-cutting tool. Subdivide the circumference into three equal parts and drill holes to clear the fixing bolts. When the adaptor is placed into position, the bolts should enter the threads in the chuck body without any suggestion of binding in the plain holes.

The commonest trouble is that resulting from constantly using the chuck for holding rough work such as castings, which do not allow the jaws to take an even bearing throughout their entire length. This practice should be avoided, as also that of holding short pieces of bar material near the front ends of the jaws for turning purposes.

Another thing to avoid is using undue strain on the key when tightening the chuck. The tommy-bar fitted to the key affords sufficient leverage, and the practice of obtaining extra leverage by supplementing the length of it is one to be condemned. A thorough occasional cleaning will do much to maintain the chuck in good working condition. To do this satisfactorily the chuck is taken to pieces. Remove the jaws and the backplate.

Much can be done to restore a chuck that has become out of condition owing to straining or wear of the jaws. Where jaws are worn so that they grip only on the back end, as shown in Fig. 66, they can often, provided that they are not too bad, be corrected by lapping. Fix the jaws rigidly by expanding them into a true ring, such as a ring from a ball-race. The lapping process is then carried out with an expanding lap held in the tailstock, as in Fig. 67. (See last month's issue.)

### Universal Holder

The universal work-holder or fixture illustrated in Fig. 68 is simple to make and has the added advantage of the fact that in its present form it can be constructed from

material that is easily obtainable. No castings are required.

It will be noticed that there are three main parts, namely, a pair of v-blocks and clamps, a circular base, and a narrow-slotted angle-plate. The base is adjustable in a vertical direction on the angle-plate and may be locked in any position within the restriction of the slot. Independent of this the centre of vees may be set to lie in a vertical or horizontal position, or, for that matter, at any angle between these positions.

### The V-block Unit

This is removable and is extremely useful in the preparation or marking out of parts. Further, it may be used on a drilling machine in the usual manner for holding bars or

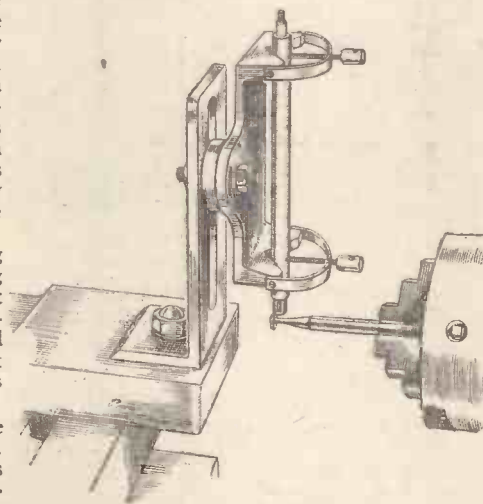

Fig. 68. — The universal holder.

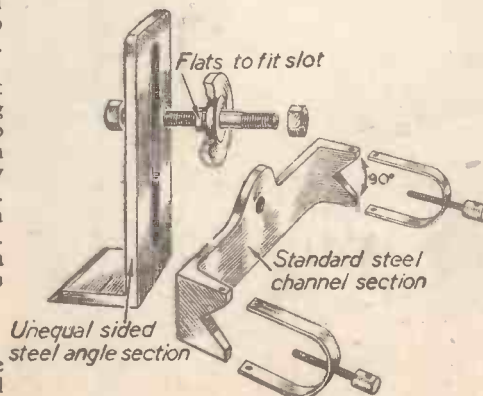

Fig. 69. — Components of the universal holder.

shafts whilst drilling pin or cotter holes. A hole often has to be drilled in a shaft or piece of bar material at an angle other than 90 degrees to the axis, as in the case of the cutter holes in certain types of boring bars. Such holes are easily drilled with the aid of the complete fixture clamped to the table of the machine. To overcome the difficulty of starting the drill on an inclined surface, a shallow hole is drilled in the correct position, the depth being governed by the diameter of the hole before the shaft is elevated to the intended angle. This precaution will prevent the point of the drill from running down the inclined surface of the material. Spot-facing or counter-boring can be, where necessary, carried out with a pin drill at the same setting.

### Cutting Keyways

For use on a lathe the fixture is bolted in place of the tool-holder. The hole in the base of the angle-bracket is passed over the centre stud of the tool-holder, with the clamp plate removed, of course, and clamped down with a distance piece and a nut. Where the lathe is fitted with an American type tool post, a stud screwed into a plate to fit the slot will be necessary.

With a suitable cutter mounted in the chuck, any type of keyway may be cut. Fig. 68 shows a shaft after cutting a woodruff keyway. For cutting a key or feather-way with an end mill the v-blocks are set to bring the shaft in a horizontal position. Slots in a tube are produced in a like manner.

Squares are milled by releasing the clamping screws and turning the shaft in the vees after the completion of each face. Thus it will be seen that any round material of a size within the limits of the v-blocks, and that will span them, can be conveniently held for this class of machining. Bushes or bush-like objects can be mounted on a mandrel to facilitate the process.

Fig. 69 shows the various parts comprising the fixture. The angle-bracket is made from a narrow piece of structural angle steel and the v-blocks from channel section. No dimensions are given, as it will be realised that they must necessarily vary according to the average size of the work being handled and the size of the lathe. Where the height of the angle-bracket equals 4in., its width should equal 2in. After removing all burrs and rounding the corners, the front and bottom should be carefully filed flat and square with each other. The long slot on the front is drilled and filed out parallel, and a short slot made in the base to suit the stud on the top slide of the lathe. A thick washer is turned from cast iron, the outside diameter being equal to the width of the angle bracket.

### The Centre Stud

This should be machined solid, a flange equal to about twice the diameter of the stud being left in the centre: behind this is a smaller portion that must be sufficiently larger than the stud to allow for flats which fit into the slot. The object of these flats is to allow for vertical adjustment to be made without interfering with the previous setting of the v-blocks. The washer is bored to suit the centre of the stud, and counterbored to let the flange in flush with the surface. A pin should be fitted through the flange and into the washer to prevent movement. Mark out and drill the channel section steel to the shape shown. The projecting radius is equal to that of the washer, and the hole a good running fit on the front portion of the stud. Before cutting the vees, make certain that the largest size shaft that can be held will not foul the fixing nut which is mounted on the stud. After sawing and filing out the vees, check for accuracy with a piece of bright mild steel, measuring from the back of the channel steel, which should have previously been filed up flat.

# RADIO-CONTROLLED MODELS

Their Development, Construction and Operation

By C. E. BOWDEN, A.I.Mech.E.

(Concluded from page 164, March issue).

THE positioning of the meter or earphones socket, and the switches, are of considerable operational importance when tuning the receiver and sending the model off. These items must be handy and grouped together so that the operator does not have to dash wildly around the model when tuning, starting the engine and, finally, when launching the model. Let us first look at Fig. 18, which shows the two instruments that can be used to check up or tune the E.D. "modulated" three-valve set. The earphones are the cheap, low-resistance ex-W.D. type and plug into a panel on the fuselage side, as shown in Figs. 19 and 21. These phones are all that are strictly necessary with this system, but I always keep the meter shown in Fig. 18, for, if there is trouble, it is possible to check that the "standing current" is O.K. and that the rise in current on signal is up to the mark. These facts tell one if the grid-bias battery and the H.T. batteries are effective or require changing. The meter should show a "standing current" of not more than  $\frac{1}{2}$  milliamp when the trans-

mitter will be remembered that the relay clicks in at 2 ma. If the grid-bias battery is low the "standing current" will be too near the 2 ma. mark, and may cause the rudder to remain on. It is important for this test to switch on the transmitter, for until the "carrier" comes in the "standing current" will be higher and give a false reading for operation. This is known as the idling current. In operation the transmitter should always be switched on before the receiver in drain in the model.



Fig. 21.—The author's 8 ft. span radio model is flown by a glow plug engine. Note the tuning lever hole below the cabin window, with earphones socket and switch nearby. A tail wheel is used to assist the heavy model to take off.

order to save battery a friend presses the transmitting button. The small tuning arm on the receiver is gently moved until the loudest and strongest note is heard. The receiver is now ready for action.



Fig. 18.—The "modulated", "raised current" type of set uses an ex-W.D. earphone to tune by. The milliammeter seen on the right is useful to check up receiver "standing current" and "rise in current."

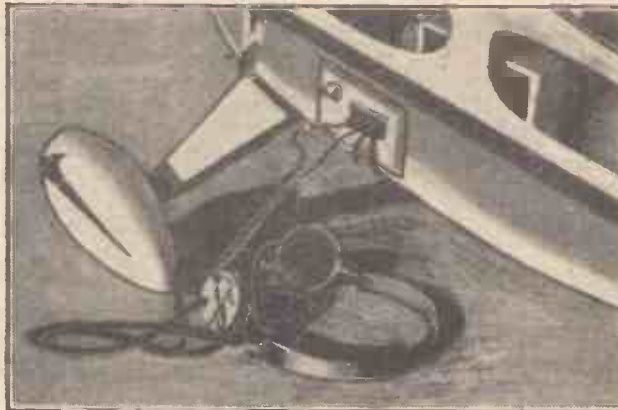

Fig. 19.—With the "modulated" E.D. three-valve set, the single switch is located side by side with the tuning earphones socket. When tuned the phones are withdrawn.

mitter is switched on but sending no signals. As the signal button is pressed the meter should read between 3 and 4 milliamps. It

plugs in the earphones (one phone will do) and at a range of about 50 yards from the transmitter listen to the note received whilst

"thyatron"—"dipping" type of receiver —has aerial lengths of between 30 in. to 5 ft. The older type of "dipping" sets

### Aerials

Aerials should be of thin insulated flexible wire, kept away from the other wiring, which should be neatly taped together to prevent movement and thereby upsetting the aerial operation. If a spark ignition motor is fitted the batteries should be at least six inches forward of the radio gear and batteries. This prevents interference. The same thing applies in a radio boat. Aerials for the E.D. "modulated" type of receiver should be of not more than three feet in length. The lightweight "dipping" type of receiver has aerial lengths of between 30 in. to 5 ft. The older type of "dipping" sets



Fig. 20.—A three-valve E.D. "modulated" receiver is seen fitted inside the fuselage of an 8 ft. span model. The receiver is slung by rubber bands to four stout hard-wood dowels built across the cabin.



Fig. 22.—The rudder flap is hinged by fabric hinges like the elevator of a control line model. The two rudder lines are of fishing cord. These are adjustable for length.

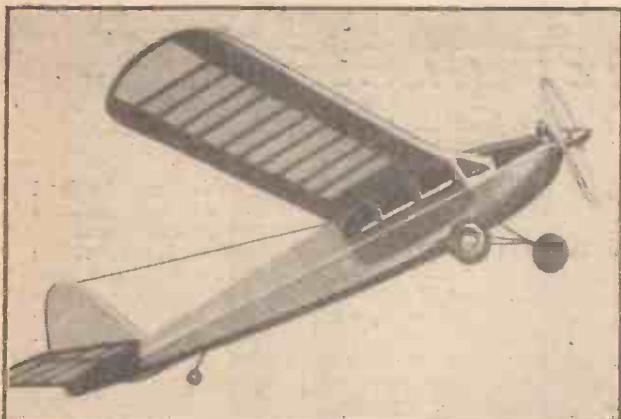

Fig. 23.—Colonel Taplin's radio-controlled model "Radio Queen" is caught by the camera climbing under radio control.



Fig. 24.—Small radio models of approximately 45 in. span are possible with the new lightweight "thyatron" gas-filled valve receivers, such as the E.C.C. and the E.D., which weigh all-up in the model around 7½ oz. This is a 45 in. span model of the author's, called "Radio Brunas."

required aerials up to about 9ft. in length for really first-class operations. These were difficult to house on most models, as the aerial should not be doubled back on itself. I use a 3 ft. aerial on my speed boat,

recently been drastically reduced by the new mini-gas-filled valve, due to its very low consumption. The wingloading of a flying model should be anything from 8 to 16 oz. per sq. ft., according to the speed of flight desired, and the engine power employed. The 16 oz. loading will fight medium winds when adequately powered. The 8 oz. loading is

22½ volt, dry deaf-aid batteries wired to produce 45 volts as H.T. current. One half-pencell suffices for the L.T. The servo, probably assisted by a twisted rubber skein, requires three half-pencells wired in series to produce 4½ volts. (See Fig. 26.)

The E.D. "modulated" receiver requires three B.122 H.T. batteries wired in series to produce 67½ volts. One D.18 deaf-aid battery is employed for L.T. current. One flash-lamp battery, Ever-Ready 1285, of 4½ volts,

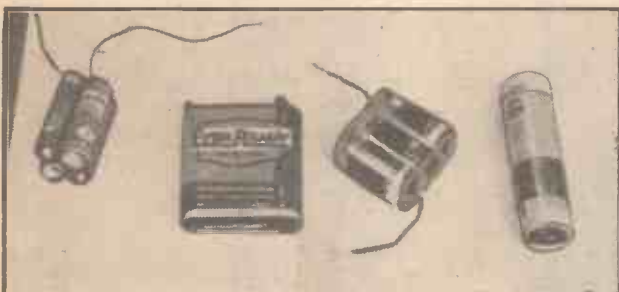

Fig. 27.—The three valve "modulated" E.D. set requires the dry batteries, seen in the photograph, to be carried by the model. On the left is the 6 volt grid-bias battery. Next, the servo flash lamp battery; next, the three H.T. batteries. On the right the L.T. battery.

stretched from the stern to a short mast. Mr. Curwen uses a 30 in. aerial on his little radio boat, *Clovis*. The aerial in this case is stuck around the deck by cellotape, as range on a pond is quite short. I always attach the ends of my aerials to a rubber band which hooks on to a wire hook fitted at the top of my aeroplane fins. (See Fig. 22.)

**Radio Batteries**

It is not so much the weight of the receiver or the servo that causes the designer of a model aircraft concern. It is the battery weight which is the trouble. This has



Fig. 25.—The author's large 8-ft. span experimental model flying boat is fitted with a "modulated" receiver.

suitable for calm weather flying and very slow speed flight with great stability. It is rather delightful to watch, and reminiscent of powered glider flight. (See Fig. 25.)

The new "dipping" gas-filled valve sets operate on the following batteries in the model. The receiver requires two B.122,

for the servo is suitable, whilst the vital grid-bias battery must be four half-pencells wired in series to produce 6 volts. My experience has been that the original early "dipping" sets, with the old type "hard" valves, required a 12 oz. H.T. battery if reliability was required against a sticking-on control.



Fig. 26.—The transmitter of the lightweight E.D. set is shown in this photograph. The radio batteries to be carried by the model are shown below, with the very light servo motor above these. Note the thumb switch and flex for sending signals. These batteries suit most modern "dipping" receivers.

**NOW READY!**

The Entirely New 12th Edition of the Famous Standard Work

**THE PRACTICAL WIRELESS ENCYCLOPÆDIA**

By F. J. CANN

Considerably enlarged, amplified and entirely re-written and re-illustrated. Complete Television Section, with theoretical and constructional data.

All the facts, figures, and constructional data of Radio and Television—Definitions, Terms, Units—Principles, Circuits, etc. Over 300,000 copies sold!

Price 21/- or 21/10 by post from:

GEORGE NEWNES LTD., Tower House, Southampton Street, Strand, W.C.2

# A Camera View-meter

A Useful Photographic Aid for Amateur or Professional Use

By J. F. STIRLING

**H**OW often does the serious photographer, when contemplating the photographing of a view or a close-up object, require to know exactly how much of the view will be recorded on the plate or film which he is using?

Naturally enough, this information can be obtained at once by setting up the camera and by bringing the view-finder or back-focusing-screen into action. But it is not always convenient—or desirable—to erect a hand-and-stand camera, or even to bring out a more portable camera, merely for the purpose of estimating how much of the view will be included in a photograph taken from any given standpoint on any given plate or film, and with a lens of any given focal length.

Fortunately, it is by no means necessary to go to the above trouble. By using a simple and portable device, known usually as a "view-meter," a quick and accurate pre-determination of the above-mentioned factors can be made in an instant.

There are various types of view-meters, but the one described here is the simplest of them all, and for average work it is, in practice, quite accurate.

As will be seen from the accompanying illustrations, the view-meter consists merely

will readily fold up and fit in an inside pocket.

## Construction

To make it, a strip of wood is required (mahogany is about the best), 12½ in. long, 1½ in. wide and about 3/16 in. thick. To one end of this wooden bar is hinged a wooden strip of similar width and thickness, but only 3½ in. long. A ¼ in. dia. sight-hole is drilled centrally in the hinged wooden strip ½ in. from its upper end.

The frame, which measures 5½ in. x 5 7/8 in., should be made in ¼ in. wood.

in regard to the relation between the focal length of the camera lens and the distance between the view-meter sight-hole and the frame aperture. If, therefore, the camera has a lens of 6 in. focal length, the frame must be 3 in. distant from the sight-hole. If the camera lens has a focal length of 4 in., the distance between sight-hole and frame aperture is 2 in., whilst (in the case of larger cameras) if the focal length of the camera lens is, say, 14 in., the distance between sight-hole and view meter frame must be 7 in.

It is, therefore, advisable in the case of a view-meter of this type which is to be used in conjunction with a number of lenses of different focal lengths, to scale the horizontal bar of the view-meter for the various focal lengths which are likely to be used.

To do this, measure exactly 1 in. from the near end of the horizontal bar. Mark this distance with the figure "2." This will indicate the view included by a 2 in. focus lens. Then measure another inch onwards. Mark this distance "4" to indicate the amount of view included by a lens of 4 in. focus. Continue the scaling until you have reached the mark for the longest focal-length lens which you are likely to use.

Mark the scale numbers clearly in Indian ink or a fine black enamel. Then varnish the bar with shellac for the sake of protection.

## Dead Black Frame

It is best to have the frame a dead black, to cut out reflections which, in strong light, might dazzle the eye.

It will be noticed in the illustrations that the frame is provided with a narrow slot at its lower edge through which the scaled bar is pushed. This is a crude method of sliding the frame along the bar, but it is serviceable and accurate enough. If thought necessary, the slot may be lined with felt glued to its sides.

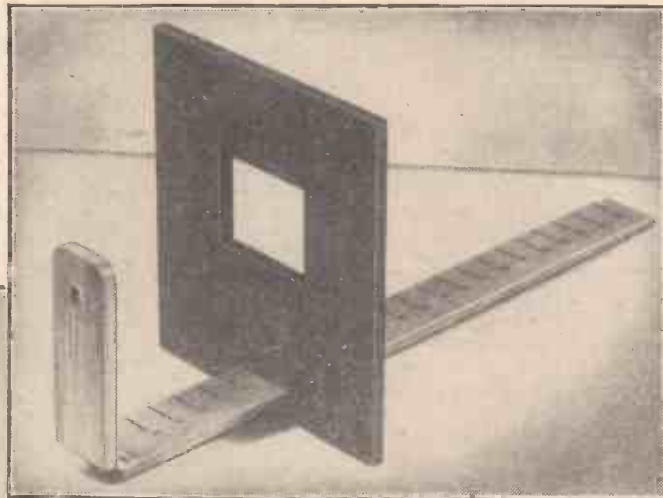

The simple view-meter described in this article. It can be used in conjunction with any lens or plate or film size.

Plywood will do for the purpose, but it is not easy to cut a sharp-edged rectangular aperture in it.

The size of the frame aperture is governed by the size of the plate or film with which the view-meter is to be used. The view-meter aperture must be proportional to the plate size or film.

Thus, if a quarter-plate (4½ in. x 3½ in.) camera is being used, the frame aperture will be 2½ in. x 1½ in. If the camera is of the ever-popular 3½ in. x 2½ in. size, the frame aperture will be 1½ in. x 1¼ in., whilst if the professional "half-plate" size (6½ in. x 4½ in.) is to be used, the view-meter frame aperture will be 3½ in. x 2½ in.

The centre of the cut-out frame aperture must coincide with the centre of the view hole in the hinged upright member. If this detail is not attended to in the construction of the view meter the device will be inaccurate.

If one has a number of cameras of different sizes, it may be convenient to make the same number of view meter frames in order that the device can be adapted for use with all the cameras.

It will have been noticed that the dimensions of the frame aperture are exactly one-half that of the plate or film size with which the view-meter is to be used.

## Scaling the View-meter

The same proportion must also be kept

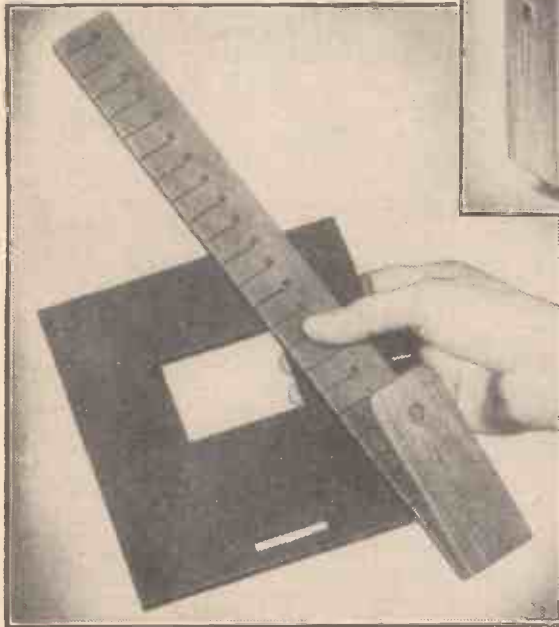

The device folded up for slipping into a large pocket.

of a rectangular frame having a central opening, and arranged to slide along a scaled or graduated rod or bar which is provided with an upright member carrying a sight-hole.

## How it Works

Suppose, with this device, we wish to ascertain the extent of view which would be included in a negative made on a quarter-plate taken from any standpoint with a lens of 6 in. focus. We merely slide the rectangular frame to the scale-number "6" on the bar and apply an eye to the sight-hole. The precise amount and extent of view is thereby seen at once, and without the trouble of erecting or even bringing out the camera.

The view-meter is light and portable, and

## BOOKS FOR ENGINEERS

By F. J. CAMM

Refresher Course in Mathematics, 8/6, by post 9/-.

Newnes Metric and Decimal Tables, 3/6, by post 3/9.

Newnes Electrical Tables and Data, 10/6, by post 11/-.

Slide-rule Manual, 5/-, by post 5/3.

Mathematical Tables and Formulæ, 5/-, by post 5/3.

Published by

GEORGE NEWNES, LTD. TOWER HOUSE, SOUTHAMPTON STREET, STRAND, W.C.2

# B.R. New Standard Locomotive

## A Brief Description of the Chief Constructional Features

THE first of 159 British Railways' standard locomotives to be built in 1951 has just been turned out from Crewe Works. It is a Class 7, 4-6-2 mixed traffic locomotive, No. 70,000, to be named "Britannia."

Like the other B.R. standard types, which will appear during this year, it has been designed and built under the direction of R. A. Riddles, Member for Mechanical and Electrical Engineering, Railway Executive.

Although Derby is the parent office for the design of this particular type, important sections were designed at Brighton, Doncaster and Swindon as part of the policy of using the resources of all the regional mechanical drawing offices to cover the standard types as a whole.

Having two 20in. x 28in. cylinders, 6ft. 2in. dia. coupled wheels, 250lb./sq. in. boiler pressure and a starting tractive effort of 32,160lb., No. 70,000 is intended for main line passenger and fast-fitted freight services of the kind now undertaken by W.R. "Castle," L.M.R. rebuilt "Scot," E. & N.E.R. V2 class, and S.R. "West Country" locomotives, having equal or better route availability.

The first 15 of the 25 engines of this type to be built at Crewe, Nos. 70,000-70,014, will be allocated to the Eastern Region for service in East Anglia. The last 10, Nos. 70,015-70,024, will go to the Western Region.

Leading dimensions and weights are shown under the accompanying diagrams, and the following notes describe some of the principal features.

### Boiler

The boiler is the normal design with riveted joints throughout. The shell is of high tensile carbon manganese steel and the barrel consists of two rings, the second ring being tapered and forming a true cone. The two rings are rolled from 19/32in.-thick and 21/32in.-thick plate respectively, the outside diameters being 5ft. 9in. at the front and 6ft. 5 1/2in. at the firebox end.

The smokebox tube-plate is of the drum-head type, 3/4in. thick, and there are 40 large flue tubes 5 1/2in. diameter outside, 7 S.W.G. thick, and 136 small tubes 2 1/2in. diameter outside and 11 S.W.G. thick. The length between tube-plates is 17ft.

The regulator is of the Superheater Com-



The new British Railways' Locomotive "Britannia," No. 70,000, in standard livery ready for a trial run.

Photo by courtesy of British Railways.

pany's multi-valve type, and is incorporated in the superheater header fitted in the smokebox. Access to the regulator valves is by a detachable cover in the top of the smokebox.

The boiler is fed with water through two separate clack valves placed at approximately 30 deg. on each side of the vertical centre line of the front barrel. Two direct loaded safety valves are mounted on the hind barrel immediately behind the dome.

### Firebox

A "Belpaire" firebox with wide grate is fitted. The steel wrapper plate is 1/2in. thick and the inner firebox is of copper and has a 3/8in.-thick wrapper plate. The front of the firebox is extended into the boiler barrel to form a combustion chamber having a 1in. thick tube-plate. All firebox waterspace stays are of monel metal, fitted with steel nuts inside the firebox. The roof, longitudinal and transverse stays are of steel, the former being riveted over outside the steel wrapper.

The firebox is 7ft. long outside, the width tapering from 7ft. 9in. at the front to 7ft. 4in. at the back, giving a grate area of 42 sq. ft.

The boiler and firebox are lagged with a mattress.

### Grate and Ashpan

A rocking grate is provided consisting of 12 rocking sections, six each side of the centre line. Each rocking section carries 14 renewable firebar units, making a total of 168 units for the whole grate.

The ashpan has three hoppers, one between and one each side of the main frames, and is of the self-emptying type, having bottom flap doors on the hoppers connected by a shaft with universal joints and operated by a lever at ground level. Front damper doors on each hopper are opened and closed by screw gear worked from a handwheel on the fireman's side of the cab.

### Smokebox

This is of the cylindrical type, resting on a fabricated saddle. The blast pipe has a plain circular cap of 5 1/2in. nozzle diameter, which incorporates the blower ring. The smokebox is of the "self-cleaning" type, having plates and a wire-mesh grid so arranged as to prevent accumulation of ash in the smokebox when the engine is working.

On the right-hand side is mounted a tri-tone chime whistle, operated from cab by flexible cable passing down the right-hand handrail on the boiler.

### Main Frames

The main frames are 1 1/2in.-thick plates spaced 3ft. 2 1/2in. apart, the centre lines coinciding with the centre of the axlebox guide faces. The axlebox guides are welded integrally with frame plates and are fitted with manganese liners.

The rear end frame extension consists

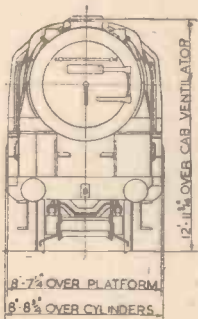

Front end elevation.

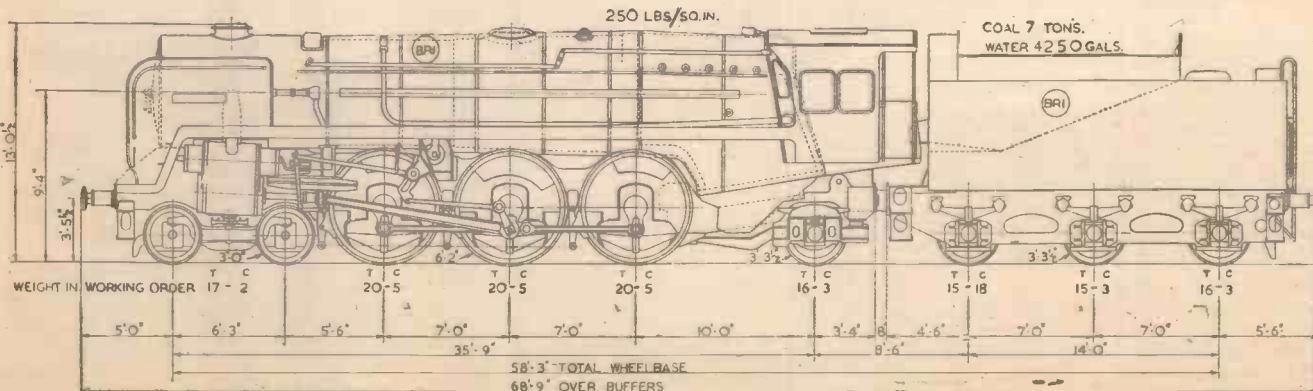

Side elevation of the new locomotive and tender, giving some of the leading dimensions.



The new locomotive under construction in the erecting shop.

Photo by courtesy of British Railways.

of two 2in.-thick slabs riveted to the main plates behind the trailing coupled wheels and carrying a fabricated dragbox at the hind end.

A single drawbar transmits the tractive effort to the tender through rubber springs.

#### Axleboxes

The engine and tender are carried on Timken self-aligning roller bearing axleboxes throughout, those for the bogie and coupled axles being of the non-split cannon type. The faces of the axleboxes in contact with the horn guides are provided with manganese steel liners welded to the body of the axlebox.

#### Springs and Suspension

All springs for engine and tender are of the laminated type with plates of carbon steel, which are secured in the spring buckles by a vertical centre rivet. Underhung spring brackets with rubber damping pads and hangers in tension are provided for the coupled axle springs, which have a span of 4ft. when loaded.

#### Cylinders and Valve Gear

The two outside cylinders are 20in. diameter and 28in. stroke, and are steel castings with cast iron liners, both in the barrel and valve chest. The 11in. diameter valves have a steam lap of  $1\frac{11}{16}$ in. and lead of  $\frac{1}{4}$ in., and are operated by valve gear of the conventional Walschaerts type, giving a travel in full gear of  $7\frac{1}{2}$ in. and full gear cut-off of 78 per cent. The slidebars are of the three-bar type with underhung crosshead.

Lubrication of motion pins is by grease nipple and gun, those for the reversing shaft and expansion link being grouped together on the motion bracket. The eccentric rod big end runs on a "Skefko" self-aligning ball bearing.

Reversing is by handwheel and screw, the latter being situated at the reversing shaft lever and rotated by a tubular shaft from the cab.

The coupled wheels are 6ft. 2in. diameter on tread, the tyres being shrunk on and secured by two small lips, one each side of the wheel centre, there being no separate securing ring, studs or rivets. Built up weights in the wheels balance the revolving and 40 per cent. of the reciprocating weight.

#### Bogie and Pony Truck

The bogie has four wheels of 3ft. diameter on tread, and is carried on "Timken" roller bearing axleboxes of the non-split cannon type. The engine weight is carried by side bolsters and laminated springs fitted in compensating beams. Side-play control

of the bogie is by means of double coil springs.

The pony truck wheels are 3ft. 3 $\frac{1}{2}$ in. diameter on tread, and are fitted with "Timken" roller bearings running in outside axleboxes.

#### Cab and Fittings

The cab structure is carried by cantilever supports attached to the firebox backplate

and by a diaphragm plate at the dragbox, this arrangement allowing full freedom for the cab to move with the boiler as expansion takes place. All boiler fittings and pipes are kept free from the main frames to avoid differential expansion and secure freedom from fracture due to this cause.

All the driver's controls are grouped to give easy access and operation, the vacuum brake, sanding and blower valves being carried on a control column at the driver's right hand.

Sanding is by steam, and is fitted to the front of all coupled wheels and the rear of the driving wheels.

#### Tender

The tender, which is carried on six wheels of 3ft. 3 $\frac{1}{2}$ in. diameter, is arranged to give a good view to the rear when running tender first. The welded tank has a large radius at the corners to facilitate the welding of the plates. The coal bunker is of rectangular shape and is narrower than the tank.

Two external feed water sieve boxes are provided to collect dirt and foreign matter from water before passing to the injectors, the sieve portion being easily withdrawn for cleaning or renewal purposes. Water pick-up gear is provided.

The tender water and coal capacities are 4,250 gallons and 7 tons respectively.

#### Braking

The engine and tender have steam brakes which can be worked independently or in conjunction with the vacuum brake by means of a separate driver's valve.

## New V.H.F. Transmitting Station

Built by the B.B.C. at Wrotham, Kent

**D**URING 1945 the B.B.C. Engineering Research Department began a series of tests in order to get first-hand information on the possibilities of broadcasting on very high frequencies (V.H.F.). It was decided to carry out comprehensive tests at high power and to this end a station was built at Wrotham, Kent, to carry out experimental transmissions. Situated about 20 miles south-east of London the station is just off the main London-

Folkestone road, on one of the highest points in Kent, and consists of a single-storey brick building and a 470-foot mast, the base of which is 730 feet above sea level. Two transmitters, A.M. (amplitude modulation) and F.M. (frequency modulation), are controlled and monitored in a single kiosk, which has windows looking out on to the transmitter hall so that the engineer on duty gets a clear view of the transmitters he is controlling.



Engineers taking readings at the amplitude modulation (A.M.) transmitter.

# Autobiography of a Gadget Maniac—1

YOU may ask the question: What is a Gadget Maniac?

Let us get this quite clear at the beginning. A gadget maniac is not Beach-comber's inventor, who, as you will remember, invented a machine whereby a pianist could read a piece of music nailed to the back of a piano. Nor indeed has he any affinity to Dr. Strabismus of Utrecht; on the contrary, the gadget maniac is one of those lunatics who, by their particular disease, are so logical that they are maniacs.

His first step in the wrong direction is when he sees something that somebody else has invented and he says to himself: "That would be useful!" Secondly, he says: "I must find out how that works." His third step on the downward path is to say: "I must have one of these for its usefulness, also, it would amuse my friends and, incidentally, also annoy them, because they don't know where to get one!"

Well, you might say that this is a selfish attitude and perhaps there is a certain amount of egotism in it. But there is also tragedy. Because, although the gadget maniac discovers the gadget, the moment his friends have seen it, they find out how to get one themselves and eventually it becomes a household word. That, of course, stimulates the gadget maniac to go in search of more modern and better gadgets. So the poor soul never gets to the end of his self-imposed Calvary. Indeed, a tragic personality, he goes searching the world like the Wandering Jew of fiction, searching for a button that will act as a crown-cork opener, without seeming unsightly, thus providing every man with a crown-cork opener automatically on his suit; or indeed a Pianola with magnetic keys whereby the fingers of the operator are tipped with metal, thus attracting the fingers to the keys, giving the impression that the operator can really play the piano.

## Improving Our Daily Lives!

Let us take a few of the things that the gadget maniac always seeks for but which civilisation has so far denied him. Let us try to look at a few of the things which civilisation should certainly have improved on for our daily lives, but, as far as I am aware, has never yet done so, and leaves the gadget maniac on his continual and restless search.

Now to take one small example. A feather duster is a very useful thing. In fact, for dusting books, it is the only thing. But nobody as far as I know has ever thought of inventing a feather duster which would dust your books, and yet blow the dust into a collecting bag instead of scattering it again all over your room. You see, there the gadget maniac is up against it because all housewives seem to think that by knocking the dust off one thing, they eliminate the dust. Of course, they don't do anything of the sort. All they do is to knock it on to something else.

Some years before the war a friend presented me with a standard lamp in which was incorporated an alarm clock mechanism. Furthermore, an electric attachment connected with your kettle. As the alarm bell rang, so the light went on and the kettle started up.

Now that was a step in the right direction. But for the benefit of bachelors in these servantless days, the thing should be carried much further. For instance, the front door should open when a switch on the bedside control-panel is operated. Again, all the electric fires should be switchable while lying in bed, and a little elementary thought should provide a means of turning on and off the

By THE MARQUIS OF DONEGALL

bath water and regulating the temperature from the same panel.

Windows should open and shut and a loudspeaker device should enable the recumbent bachelor to converse with a would-be caller standing outside the front door. Such a device does exist for the housewife, but I have never heard of all these things being incorporated in a bedside panel.

Now the reason that most of us rise just a little too late every morning, and spend the rest of the day chasing those stolen minutes of warm dozing, is the contemplation of that frigid walk to the bathroom, and the even bleaker wait until there is enough hot water in the tub to get into it.

Here we are up against a more difficult problem. Obviously, either the bath must come to the bed, or the bed must go to the bath. Probably the latter is the easier, as it

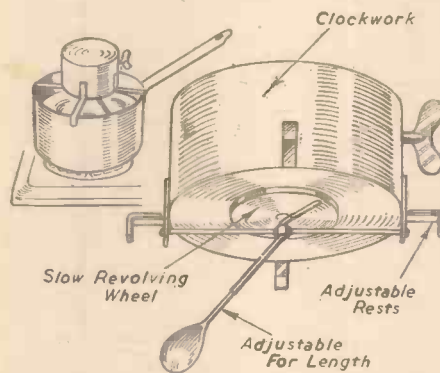

A suggested automatic gadget for stirring jam, etc.

involves only widening the bathroom door, in laying a pair of rails and fitting a small electric motor. To bring the bath to the bed would, I fear, involve some form of elastic plumbing which is beyond my meagre powers of invention.

The problem of shaving has long been the Mecca of gadget inventors. It is insoluble, for the simple reason that the two essentials of comfortable shaving are incompatible. First, the civilised way to shave is in the bath, and, unless you are determined to commit suicide, you cannot use an electric shaver. Yes, battery shavers exist. But batteries are a curse. Whoever has the battery he wants just when he most wants it?

## Lighters

Take lighters. A more inefficient lot of contraptions than the majority of the hundred or so that have passed through my hands it would be difficult to conceive. To this day, as far as I know, there is only one on the world-market that has spare flints arranged on the principle of bullets in a revolver. So far so bad. But what about the burned-up wick—true, a less frequently recurrent nuisance than the missing packet of flints! The everlasting wick should give some human benefactor food for thought. Some of the patients in our mental hospitals might give up squaring the circle in favour of this most knotty problem.

The spillable ink-bottle—quite a simple matter on the valve principle, surely? Bolts being much safer than locks, has anybody invented a bolt that can be operated from the other side of the door if you know the secret?

One could go on for ever, but, finally, it might be possible to devise some painless contraption which would remind doctors not to leave cyanide of potassium all round the countryside in motor-cars!

As a child they put me in a pen surrounded by coloured balls on rails. It was a fluke, I admit, but I discovered that the mechanism which enabled the sequence of colours of the balls to be altered also operated the opening of the pen. This opened up an entirely new world from which, I hope, I have never looked back.

It was at this point that I first learned that gadgeteering is not all milk and honey.

We had a lovely fire in the house. The fire brigade put it out in less than five minutes. One of the firemen took off his shining brass helmet to mop his brow. That experiment cost me a badly cricked neck for about three weeks.

There was rather a dull period after this until the Hon. Charles Rolls appeared over our house and waved to my mother from his "flying machine." This started a lot of trouble because, although the Hon. Charles agreed with me that he could perfectly well take me up, sitting on his knee, Mother took a poor view of the whole thing. So I had to wait some 13 years before experiencing the joys of a "flying machine."

That, however, did not prevent the destructive child from depleting the whole house of blotting-paper. It found out that by rolling up the end of a piece of "blotch" and folding it down the middle you could make a passable imitation of Mr. Rolls's contraption.

Furthermore, it would glide quite nicely, sometimes for a considerable distance.

## Gadget for the Bullring

There came a period in Spain—a backward country in 1914—with little to interest the gadget-seeker. However, I found myself wondering about the horrible cruelty to the horses in the bullring as I saw them depicted in the "aficionado" magazines. My mother had always been connected with societies formed to mitigate unnecessary suffering of animals, and I sketched out a kind of blanket-shield which my mother took to the head of the infant Spanish Society for the Prevention of Cruelty to Animals. This was a gentleman called Señor Julia, who worked on the British Embassy staff throughout the last war and was duly decorated.

It took no less than 14 years for this idea to become acceptable. The benevolent dictator, Primo de Rivera, introduced the "peto"—a development of my shield—which he made obligatory in all Spanish bullrings.

On arrival at school in Switzerland I acquired a truly magnificent gadget which was the envy of the population. People would stop and stare as I bicycled up the extremely steep and mile-long hill from Territet to Les Planches, where my school was perched on the mountain-side.

The fact is that an American had brought over a bicycle with a 12-speed gear. By pedalling like fury you could go up almost any gradient in the world, and naturally I pestered both this innocent American and my mother until I became the proud owner of this contraption. I believe that these freak bicycles are well known to pioneer cyclists, but I have never seen another.

(To be continued.)

# A Sensitive

## Constructional Details of a Compact Precision



Fig. 1.—The completed resistance bridge, with battery.

As the foundation of the experimenter's electrical equipment, a D.C. bridge excludes guesswork so far as resistance is concerned. With its aid accurate resistances can be produced, meter resistances measured, and shunts and series resistances added to provide other ranges. The 9-volt battery, shown in Fig. 1, enables accurate measurement to be made between 1/10th ohm and 1,000,000 ohms, three-figure accuracy being obtainable from 10 ohms to about 200,000 ohms. Over part of the range a fourth digit can be found by noting galvanometer readings and interpolating. In Fig. 1 a radio resistor is shown connected to the front terminals, but the accuracy of measurement is, of course, greater than is necessary for ordinary radio work.

### The Null Indicator

To achieve the above range and accuracy, a sensitive indicator is needed. Without valve amplification this entails a microammeter. Fortunately, these expensive instruments may at present be obtained cheaply in the form of ex-R.A.F. blind-landing indicators. A visual indicator of the cross-over pointer type, containing two 60-microamp. meters can be got for a few shillings. Usually it is necessary to saw through the soft iron jacket encasing the indicator. This is best done with a fretsaw, using a fine metal saw blade. All dust must be removed—especially from the hands—before opening the inner case, as a particle lodging in the gap of a meter will cause its movement to stick.

One meter is removed, and if great care is exercised to avoid damage to the springs and pointer, the remaining meter can be made a centre zero instrument by moving the lower spring adjuster, and drilling new holes in the case. The zero adjuster buttons on the top of the

case can be removed and the holes filled with black sealing-wax. One of them can be re-positioned centrally to engage the top spring adjuster. The leads from the instruments should be brought direct to the terminals.

An evenly divided scale, say of degrees, should be fitted. I have calibrated mine roughly in microamperes, although this is unnecessary. The scale can be glued on the iron scale-plate if the latter is temporarily removed after the central position of the pointer has been marked on it.

### Switches

Four low-resistance switches are assembled on the lower panel. A device to make the switch stop positively at each stud is procured in a wafer switch. Only the "locator" and shaft are needed, the wafer itself being taken off. In the type I found most suitable, the shaft (which was more than long enough) ended in a tongue 1/16in. thick (see Fig. 4). This can be strengthened in its attachment to the shaft by soldering. One small bracket (F. in Fig. 9) is fastened to the tongue of each "locator," the tongue having two holes drilled and tapped 8 B.A. for this purpose. Five leaves of phosphor bronze (G in Fig. 9) are bent and secured to each bracket by an 8 B.A. bolt. Three feet of 33 S.W.G. phosphor bronze strip 5/16in. wide should supply all the leaves needed. Each group of leaves

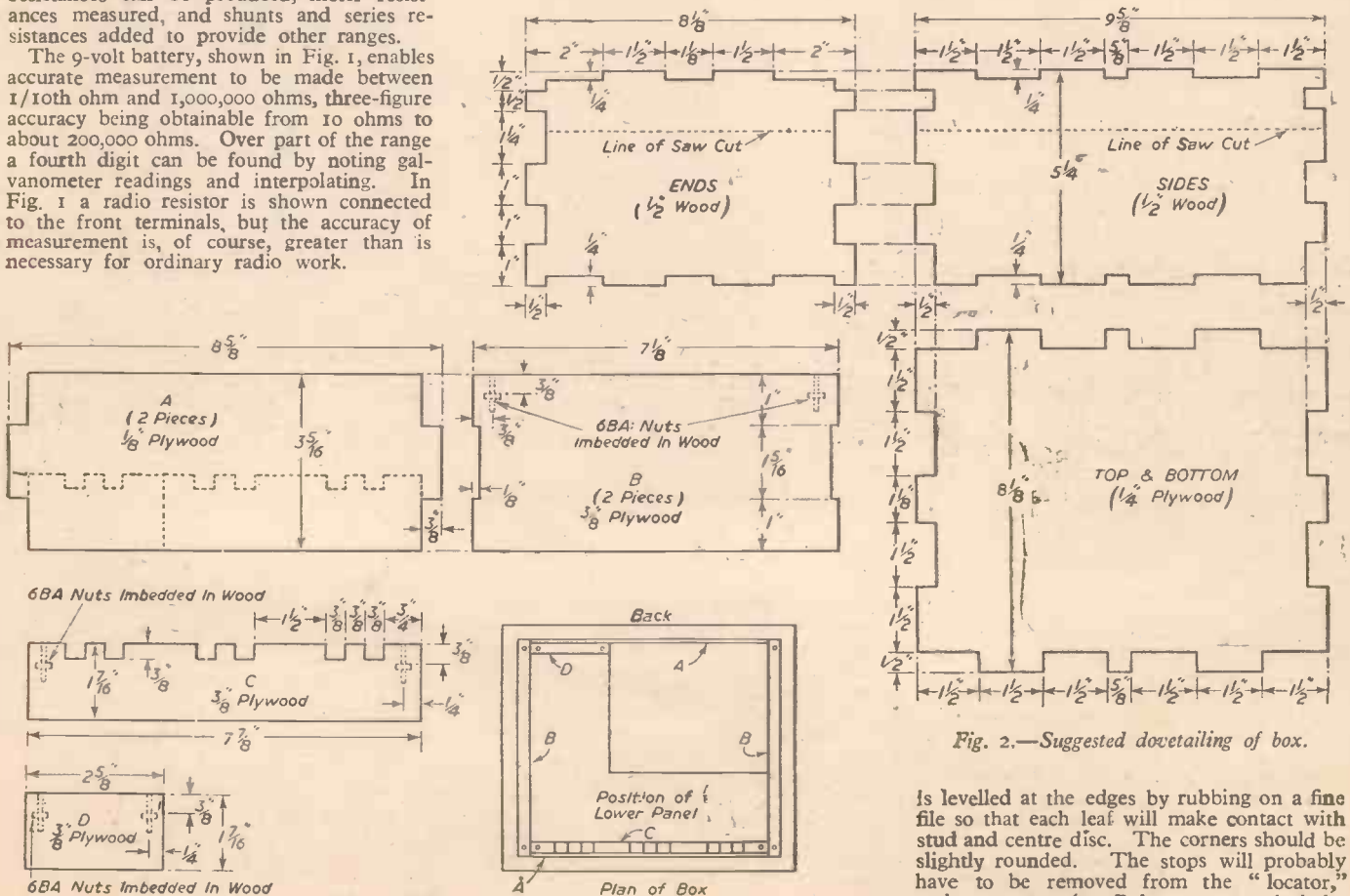

Fig. 2.—Suggested dovetailing of box.

Fig. 3.—Details of supports for panels.

is levelled at the edges by rubbing on a fine file so that each leaf will make contact with stud and centre disc. The corners should be slightly rounded. The stops will probably have to be removed from the "locator," and new ones (10 B.A. countersunk bolts with nuts) fitted in the required limit positions.



# Resistance Bridge

Instrument of Wide Range

By W. CLELAND

The "locators" are supported on brackets of type E. (Fig. 9). A 1/16in. thick aluminium plate had to be added to the top of each bracket to enable the nut to tighten on the bracket. The studs are 2 B.A. half-inch un-slotted hexagonal head brass bolts, and the tiny burr in the centre of the head can be removed by one or two rubs on a file. The centre discs of 19 S.W.G. brass are raised on discs of 1/16in. paxolin, and secured by 2 B.A. countersunk brass bolts, 3/4in. long.

### Terminals and Conductors

The pair of 1/4in. Whitworth terminals at the front are shown in section in Fig. 10. They screw into nuts fastened on the lower panel. Two holes are drilled and tapped in each nut for 8 B.A. securing bolts. Brass tubes carefully cut to size and with their ends smoothed are fitted on the screws of the terminals to improve the connection and prevent uprooting of the nuts.

Copper wire 3/4in. diameter is used to connect these nuts with other points, as shown in Fig. 7. The dotted portions run 1/4in. above the panel. The thick wire is flattened at the ends, bent round the nuts, and soldered. Solder should be kept off the tops of the nuts where the tubes rest. The other heavy connections are made on the underside of the lower panel (Fig. 8) and consist of 19 S.W.G. brass strips, cut to the shapes given in Fig. 11.

pleted, the bobbins received two coats of black cellulose enamel.

Eight discs of 1/16in. paxolin are used to mount the bobbins, four of the discs having projections as shown in Fig. 12, to prevent any turning. The sectional elevations, Figs. 4 and 5, show the bobbins mounted in pairs on 6 B.A. brass bolts, 1 1/4in. long, between the paxolin discs.

### Top Panel

On the left side of the top panel (Fig. 6) are a pair of small terminals for the battery. Of the two potentiometers on the top panel, one is for battery current, and the other to vary the sensitivity of the galvanometer. The former is a 250,000 ohm logarithmic volume-control with built-in switch. The latter, of 5,000 ohms, proves almost unnecessary since the logarithmic potentiometer gives a gradual increase; and it might well be omitted.

The push-button switch at the corner of the top panel must occupy little space. A contact assembly from a relay is bolted on the underside of the panel, and a push-button arranged above it. This can be part of an old radio pull-out switch.

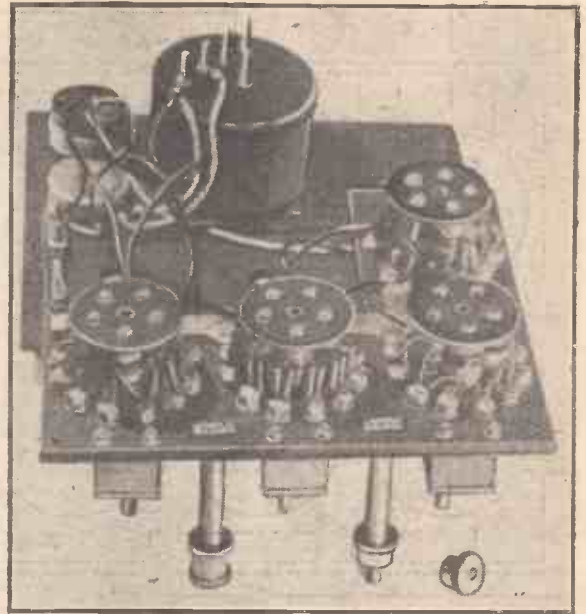

Underside of bridge showing layout of components.

are at first connected only at the top panel.

### Resistance Wire

The Constantan wire used may be obtained through a scientific instrument maker: 2 oz. of No. 30 S.W.G. and 1 oz. of No. 44 S.W.G. (double silk covered).

An accurate 10 ohm standard is required. With accuracy to one part in 1,000 this standard will not be expensive. Also required is an equal ratio, which can be made, using a base-board such as those sold for switches. Three terminals are fitted, and about two yards of No. 44 S.W.G. Constantan is doubled and soldered at the middle and ends to the three terminals. Before this it is rolled up in a hank, and a little sealing wax will hold it in place. A disc may be fastened over the recess in the board.

### Ten-ohm Bobbins

By calculation about 62 1/2in. of No. 30 S.W.G. Constantan should give 10 ohms, but a length of, say, 64in. should be cut in case there is an appreciable deviation. This is doubled, tied to the bobbin with thread, and wound on. It can be held in place with wax from a candle. The ends are bared and wrapped round 3/4in. pieces of No. 20 S.W.G. tinned copper wire. The equal ratio, 10-ohm standard, and 10-ohm bobbin, are connected together with heavy wire to form a bridge, and the four flexible leads from the top panel are soldered at the appropriate points. More of the Constantan

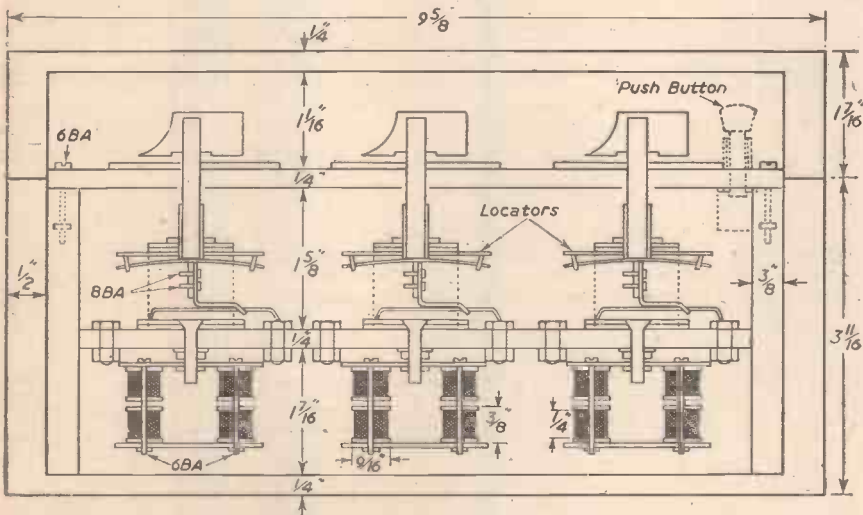

Fig. 4.—Sectional elevation through bridge.

### Bobbins

Thirty-four bobbins are required for the standard and ratio resistances. For these, copper washers 1/16in. thick, 9/16in. outside dia., and 3/16in. dia., were soldered to 3/4in. pieces of copper tube, 3/16in. outside diameter. Each washer was first smeared with glue and pressed on a sheet of paper which was cut around the washer. The centre of the paper disc left on the washer was punched out with a piece of tube.

To facilitate soldering a slot was cut in a scrap of 1/4in. paxolin from the side. The bobbins were slid on to the slotted paxolin and soldered without singeing the paper. To insulate the tube of the bobbin, 1/4in. paper strip was glued round it. When com-

The dials are inked on card which is stuck to Perspex discs with Perspex cement. Perspex cement is also used to stick them to the paxolin.

The wiring of the top panel should be rigid, but does not need to be heavy. The top panel is connected to the lower one by four pieces of plastic-covered wire, one foot long. These

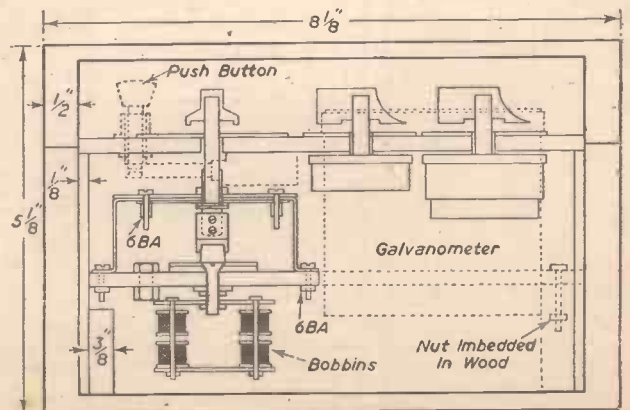

Fig. 5.—Cross section through bridge.



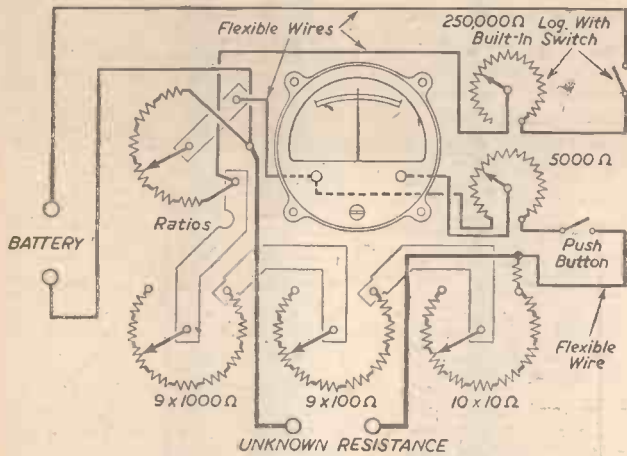

Fig. 13.—Wiring diagram of bridge.

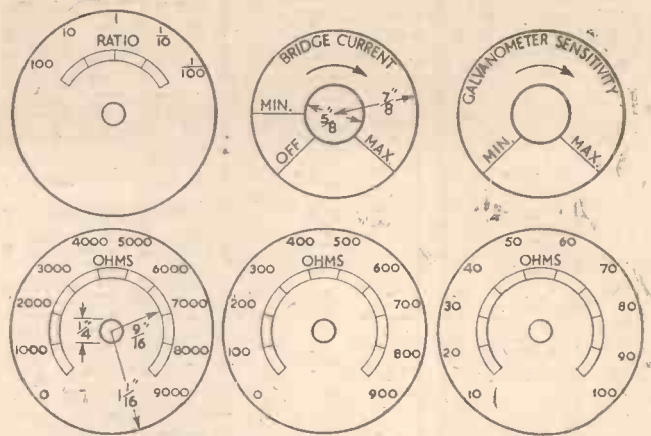

Fig. 14.—The various dials showing the graduations.

180, 22 ohms. For the 22-ohm bobbins cut about 11ft. 8in. of No. 30 S.W.G.; for the 180-ohm, about 6ft. 5in. of No. 44 S.W.G.; and for the 909-ohm, about 32ft. of No. 44 S.W.G.

The 180-ohm bobbins are adjusted exactly, and the 909-ohm bobbins are first adjusted to 910 ohms. The six bobbins are then mounted and the leads temporarily soldered to the studs, except for the outer leads (of the 22-ohm bobbins), which are connected to

a pair of terminals soldered temporarily in place, so that the leads can be easily reversed. If the unknown resistance terminals are "shorted," and the flexible leads from the top panel connected to the appropriate points, the other resistances can be switched in to give the ratios 1:100, 1:10, 1:1, by means of which the ratios can be rapidly checked, the end leads being reversed to check the reciprocals of these ratios.

The galvanometer deflections are tabu-

lated and give an idea of the excess or deficiency of any ratio. If the six ratio resistances are thought of as a tapped potential divider, it will be seen that the tappings should be moved up or down to correct the ratios. This is done in effect by reducing appropriate resistances. Only the 180-ohm bobbins are left untouched. After each small adjustment the ratios are checked over, and perfect balance is approached by stages, the work being done systematically.

## Induction Soldering

### New High-frequency Equipment

**T**HE use of high-frequency induction heating in the manufacture of the copper base of a sink-type water heater illustrates how this modern method of soldering can very often effect considerable improvements in production whilst ensuring a better and more consistent product.

The copper base is reinforced with a copper ring soldered in position so that it may carry the weight of the heater assembly and outer casing. The hand torch method of soldering results in the heating and consequently the softening of a large area of the base. As far as cleanliness is concerned this method leaves much to be desired, so that in the subsequent nickel-chrome plating process continual vigilance is needed to avoid contamination of the solutions by excesses of flux and soluble metal.

#### Localised Heat

The inherent cleanliness of induction soldering is thus of particular advantage for this application. The heat is localised so that the finished part is stronger and can be more easily polished. The solder in which a resin flux is so positioned that it flows before the solder melts is applied as a preform, and waste of the material is avoided.

The soldering process can be carried out with a 5 kW. high-frequency generator by an unskilled operator at a rate of over 250 per hour without recourse to special handling gear. The operations consist of assembling the parts with a preformed ring of solder and placing them in the heating position, using a small jig to exert the slight pressure required on the joint. The door of the screening enclosure is then closed (Fig. 1)

and the high-frequency power is applied by pressing the "start" button. Another assembly can be prepared during the heating time.

A close-up of the concentrator-type heating coil used for this application is shown in Fig. 2. A Paxolin plate (which has been removed) is used to prevent contamination of the coil by flux. The primary coil is coated with alkathene, which serves not only to keep the coil clean but also to protect it when the plant is located in a corrosive atmosphere.



Fig. 2. Close-up view of alkathene-covered work coil. The protective Paxolin cover is to the right of the coil at the rear.

The high-frequency installation for this process was manufactured by The General Electric Co., Ltd.



Fig. 1. General view of the equipment in use.

### A NEW HANDBOOK THE MODEL AEROPLANE HANDBOOK

By F. J. CAMM

312 pages.

303 illustrations.

12/6 (13/- by post).

Construction and Principles of all Types

From GEORGE NEWNES, LTD., TOWER HOUSE, SOUTHAMPTON STREET, STRAND, W.C.2



A Fine Model Sailing Ship : 00 Gauge Layout in Leipzig : Model Beyer Garratt Loco

**D**ESPITE the fact that the sailing ship has almost passed into oblivion for practical merchant shipping purposes, sailing ship models still have a very great attraction for model-ship builders. The grace and romance that the old sailing vessels carried with them over hundreds of years still cling to many lovely models of these ships, seen in exhibitions and museums.

To the modelmaker the sailing ship presents a problem of very fine, small detail work on rigging, blocks and the numerous deck fittings. The carving of a figurehead is an interesting piece of craft work in itself and the modelmaker can use his skill in bone or hard wood.

**Model of the "Naworth Castle"**

The beautiful model pictured here (Fig. 1) is the entire work of Dr. S. Rowland, of Northampton, now retired. Before settling down on shore, Dr. Rowland served twelve years at sea, seven in sail and five in steam, and he obtained his master's certificate in sail. He is a confirmed ship lover, with a special weakness for sailing ships. The Doctor is now well known in model circles for his many lovely replicas of old-time ships: the prototype of this one was the *Naworth Castle*, the last sailing vessel built for Messrs. James Chambers and Company, of Liverpool, in 1892, by the well-known builders, Messrs. Wm. Pickersgill and Sons, of Sunderland. The model was made from drawings kindly supplied by the builders.

The *Naworth Castle* was 264ft. long, 39ft. wide and had a depth of 23ft. In 1898 she passed to Knöhr and Burchard, NFL, of Hamburg, and she was then renamed *Tarpenbek*. In 1921 she was transferred to another German firm and again renamed, this time *Tamara XII*. Then, in February, 1923, she was posted missing and omitted from Lloyd's register in 1924. No details are available as to the circumstances of her loss.

The present model is to a scale of 1/4 in. to 1ft., a size which he considers to have many advantages in building a model. For instance, builders' rigging plans are drawn to this scale, which is most helpful to the modelmaker.

**Deck Fittings**

When making deck fittings and other small details, the Doctor insists on keeping to scale, so that all details are shown without overcrowding of the decks. Those who wish to do all detail work themselves, such as the making of blocks, bollards, davits, capstans,

and spars, as they can be turned in the lathe without difficulty: he contends that metal is so much stronger than wood, especially when it comes to making small upper yards, which in a scale of 1/4 in. to the foot means that they are very slender spars and are easily broken if made of wood. If, how-



Fig. 1.—A bow view of Dr. Rowland's beautiful model of the sailing ship, "Naworth Castle." This model is to a scale of 1/4 in. to 1ft., and is rich in extremely fine detail.

etc., need the use of a small lathe and a small electric drill. But nowadays it is possible to purchase ready-made scale deck fittings from the model shops, and these are often most satisfactory.

Dr. Rowland also strongly favours the use of non-ferrous metals for model masts

ever, wood is preferred, then it is better to use lance wood.

Model ships' blocks are almost impossible to make to scale in wood, and here again the commercial scale model blocks recently put on the market and made of plastic material are of great assistance: they give



Fig. 4.—A broadside view of an interesting railway model, representing a 4-8-4 + 4-8-4 Beyer Garratt locomotive, to a scale of 1/4 in. to 1ft. This exhibition model has gone to the East African Railways, Nairobi.

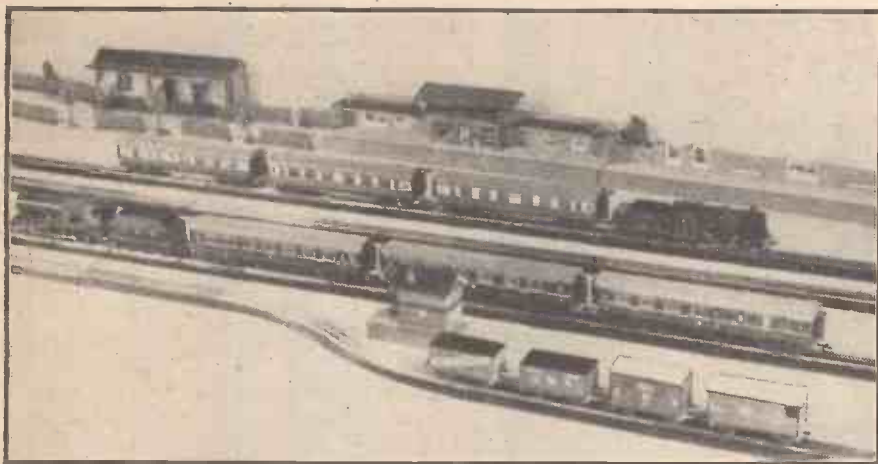

Fig. 2.—A layout showing some of Mr. W. Richter's English-style 00 gauge railway models, in their appropriate setting. Both trains and accessories have been either built entirely by Mr. Richter or have been converted by him from old German models.

a neat appearance and are not expensive. With reference to rigging, the Doctor prefers to use wire, although he admits it is more difficult to manage than silk twist. He generally uses yellow pinewood for the hulls of his models and for  $\frac{1}{4}$  in. scale carves the hull out of the solid block, having first marked out sheer and deck plans. If there is to be a figurehead then it must be a good one or it will spoil the appearance of the whole model. A figurehead made by a professional craftsman is sometimes used.

I am indebted to Dr. Rowland for letting me have his comments on ship modelling and the interesting information about the *Naworth Castle*.

**00 Gauge Layout in Leipzig**

It is always a pleasure to hear from Mr. W. Richter, of Leipzig, Germany, as he is such an enthusiastic model-railway fan. I have just received two interesting pictures showing parts of his 00 gauge layout. Readers may remember from my past comments that all this layout is built by Mr. Richter to represent English designs, either by making accessories and rolling stock himself, or by converting old German models into English-style ones.

The two illustrations, Figs. 2 and 3, this month show varied arrangements of the

track and equipment. The first shows two passenger trains, with Mr. Richter's latest coaches made up with litho papers. The L.M.S. train in the foreground is in the old company colours, but the Southern Region train behind is in the new British

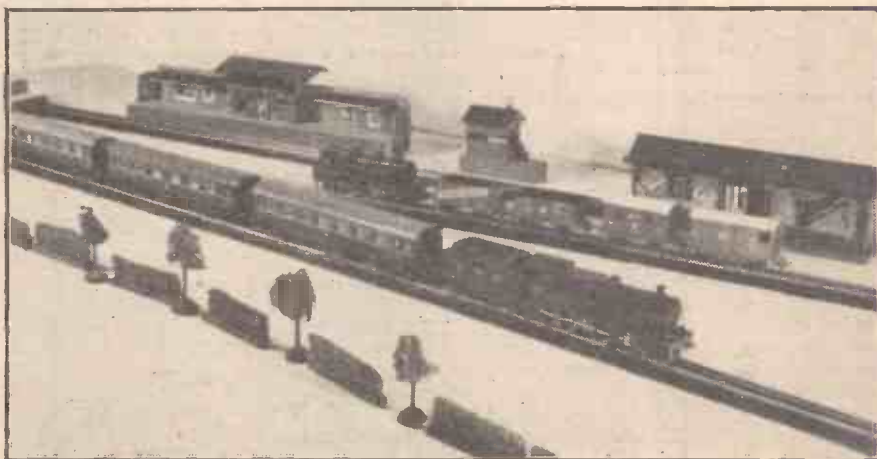

Fig. 3.—Another view of the 00 gauge models of Mr. W. Richter of Leipzig, showing an express passenger train and a small goods train.

Railways colouring. Miniature British Railways posters adorn the station walls; the signal box is an example of adaptation, as it was originally a German one, from an old "Bing" model railway.

The second illustration (Fig. 3) shows again the L.M.S. express passenger train, together with a small goods train, with wagons built in cardboard and finished with litho papers. The locomotive of the goods train has been rebuilt in English style from an old "Trix" German locomotive, and the L.M.S. express locomotive from an old German, "Maerklin" one.

In addition to these, Mr. Richter now also has an attractive-looking Pullman express, which is one of his favourites, as it is so colourful.

**Model Beyer Garratt Locomotive**

The well-known firm of Beyer Peacock & Co., Ltd., recently presented to the East African Railways a display model of a 4-8-4 + 4-8-4 Beyer Garratt locomotive. The model (Fig. 4), to a scale of  $\frac{1}{4}$  in. to 1 ft., was built for them by Bassett-Lowke, Ltd., of Northampton, and incorporated all essential details, being finished in maroon colour, with yellow lining. The model is static, without any moving parts, and was despatched to Nairobi, Kenya Colony, last autumn. It should make a most attractive exhibition piece.



A rear view of the potato harvester at work.

**POTATO HARVESTER**

A NEW British-made potato harvester known as the "Solanum" was recently demonstrated at a farm at West Horsley, Surrey. The machine is controlled by one man and is drawn by any 20 h.p. tractor, which provides the power for the many moving parts of the machine. The harvester automatically cuts off all the potato haulms or strands before they are lifted—together with soil covering—on to an endless conveyor. After the soil is broken up and shaken off, the partially cleaned potatoes fall gently into the final cleaning barrel, which revolves continuously. Any soil or stones still clinging to the crop are automatically discharged, together with the haulms. The clean and undamaged potatoes are then collected by another conveyor and discharged direct on to an accompanying wagon. It is claimed that this new machine lifts 98 per cent. of the crop and saves hundreds of man hours, as it can lift four acres of potatoes from any type of soil in one day.



**Velocity of Escape.**

SIR,—The query by "Planetas" (December issue) regarding the velocity required to escape from a planet is very interesting.

I doubt whether it is true, however, to say that "most scientific writers" put velocity of escape directly proportional to the "g" of the planet, since, neglecting resistance of the atmosphere, it is not difficult to show that V.E. is proportional to the square root of this quantity, as well as to the radius of the planet.

Consider a projectile of mass *m* ready to be fired from the surface of a planet of mass *M* and radius *r*. If the acceleration due to gravity at the surface is *g*, then by Newton's inverse square law:

Force of attraction between the two bodies  
 $= f = mgr = G \frac{mM}{r^2}$ , where *G* is the gravitational constant.

$$\text{i.e. } gr = \frac{GM}{r^2} \quad (i)$$

Also, work done in moving projectile from surface to infinity,

$$W = \int_r^\infty f \, dr = \int_r^\infty \frac{GmM}{r^2} \, dr = \frac{GmM}{r} \quad (ii)$$

From (i) and (ii):  $W = grmr$ .

Thus, for projectile to escape from planet it is to be supplied with kinetic energy  $grmr = \frac{1}{2}mV^2$ , whence *V*, the velocity of escape,  $= \sqrt{2gr}$ .

Excepting Mars, this will explain both the relationship between the values quoted by "Planetas" and, since he assumes a direct proportionality, why that relationship was so disconcerting to him. The value for Mars, however, should not be the same as for Moon (1.5 miles per second), but should be about 3.1. Perhaps there is a misprint in the book from which he takes the figures.—S. F. W. HART, B.Sc. (London, E.).

SIR,—I have read with interest the replies appearing in the February issue on this matter, and wish to thank the correspondents concerned. I cannot quite agree with Mr. Scammell that a new approach is unnecessary.

Whilst it cannot be said that spatial transport is going swiftly ahead there is nevertheless a rapidly growing interest in the subject, in which, I may say, films, radio, television, magazine and newspaper articles are all playing their part. A reader can now be expected to look for a more precise exposition of the main points of the subject: he can at present get a wrong, or at least an imperfect, idea about V.E.; he thinks it is the velocity necessary for a space ship to leave the earth which can be misleading, for in the popular treatises he learns that if one could project a body from the top of a high mountain at 20,000 or 22,000 m.p.h. (theoretically 18,000) it would get off (and keep off) the earth, the primary condition being that the motion is tangential to the surface, or in some way productive of a closely circular orbit. In fairness, I must admit that this is escape from surface only

and not from planet as a whole, and a more qualified approach to the matter would clarify this. It is now due.

Difficulty was set up in the first place by a small crop of unfortunate typographical errors in the book ("Stratosphere and Rocket Flight," Philp). The V.E. for both Moon and Mars was put at 1.5, and "g" for Mercury reads 13! Again, in the main text, in rather different vein, we read, "for a journey to the moon it is not possible to apply the ordinary simple gravitational formula  $S = \frac{1}{2}at^2$  and  $T = \sqrt{2s/a}$ " both of which are wrong.—PLANETAS (Northampton).

**Testing Spirit Levels**

SIR,—With reference to the method of trueing a spirit level mentioned in a recent issue, I feel that if the piece of timber floated is not of uniform thickness throughout its length, or if there is a heavy knot

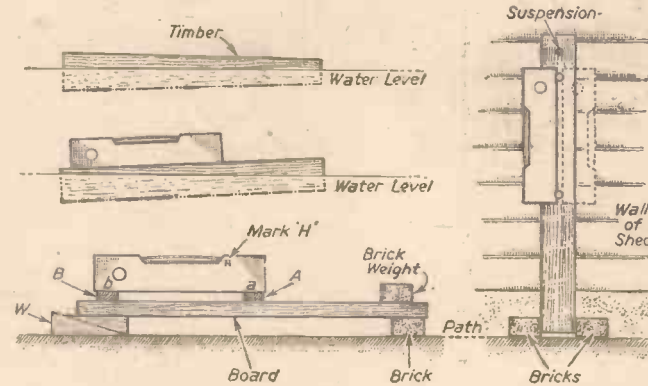

A method of testing a spirit level.—(C. A. Fone).

at one end, or if the level is not placed on it exactly central, the timber will be out of level, as indicated in Figs. 1 and 2.

An easy and quite accurate method is shown in Fig. 3. (A prerequisite is that the base of the level is truly flat and the level should be made of hardwood such as beech or mahogany. The base at either end should be tipped with brass, let in flush.) Obtain a board—rough, smooth or uneven—a little longer than the level, and nail to it, at a distance apart equal to the length of the level, two pieces of wood of a thickness sufficient to give clearance to the central portion of the level.

Support this board at its extremities on two bricks, or blocks of wood placed on a path or wall. Have a wedge "W" at one end and adjust the board as level as the eye will show (very approximately) as shown.

Put some soft putty into the bubble-tube bed and insert the tube, convex side uppermost, but embed only sufficiently to hold the tube firm. Mark, provisionally, one end of the bubble-tube "H" with a piece

of chalk or a pencil (mark on the wood adjacent).

Now place the level on the blocks "A" and "B" and adjust wedge "W" till the bubble is just to the left (or right) of the centre line on the tube. Observe the amount of deflection from centre line on the side called, say, "H." Reverse the level through 180° till "a" is adjacent to block "B" and again observe the position of the bubble. This should be on the same side "H" (chalk-marked) as before, and some distance from centre line. If it is not, adjust wedge "W" for half-correction, reverse level on blocks "A" and "B" and check. Continue thus till equal deflection is obtained, when the blocks "A" and "B" will be level.

Now gently press the side "H" (the higher) of the bubble-tube till the bubble is dead centre, reverse the level and check and finally bed the tube well home so that its centre point is just below the wood surface, and screw on the brass retaining plate for which holes have already been made.

For the vertical bubble replace the wooden blocks with large nails of the same diameter knocked in parallel, or the level will wobble. Place the board upright and nail, pendulum fashion, to the shed or wall (Fig. 4). Adjust for vertical with two bricks at the base and, by holding the level against the nails, first one side and then the other and by using the same principle as before, obtain true plumb. When the nails are truly vertical nail the lower end of the board and adjust the bubble-tube as before.

A genuine bubble-tube is part of the circumference of a circle, the greater the radius (within reason) the greater the accuracy. A straight tube should not be used. A very sensitive tube has a barrel-shaped section, but this is not necessary for industrial purposes.—C. A. FONE (Brighton).

**Varnishing A Violin**

SIR,—Your enquirer, Mr. J. Martish (Glasgow), may find the following information helpful with regard to violin varnish. The reference is: J. Michelman, Science 112, No. 2908, September 22nd, 1950. Old Italian Varnish. This may be

available in his local reference library, but in any case here are the working instructions for preparation of the varnish:—

- Wood ashes ..... 30gns.
- Distilled water ..... 300ml.
- Lime ..... 12gns.

Allow to stand overnight, filter through fine cloth until clear, add 15gns. powdered resin slowly, with shaking, allow to stand a few days, filter off the undissolved resin. Add a solution of aluminium and iron sulphate until no further precipitation occurs. Heat on water bath until precipitate coalesces, filter and dry resin in air.

The dried resin is then dissolved in turpentine until a varnish of a suitable consistency is obtained. The yield is not very great and several batches may have to be taken through in order to obtain sufficient varnish.

According to the author's spectrographic analysis this varnish is very similar to the "Strad" varnish, and the method of manufacture is based on that probably used by the old violin makers.

(Continued on page 210).

# POWER for the ambitious craftsman!

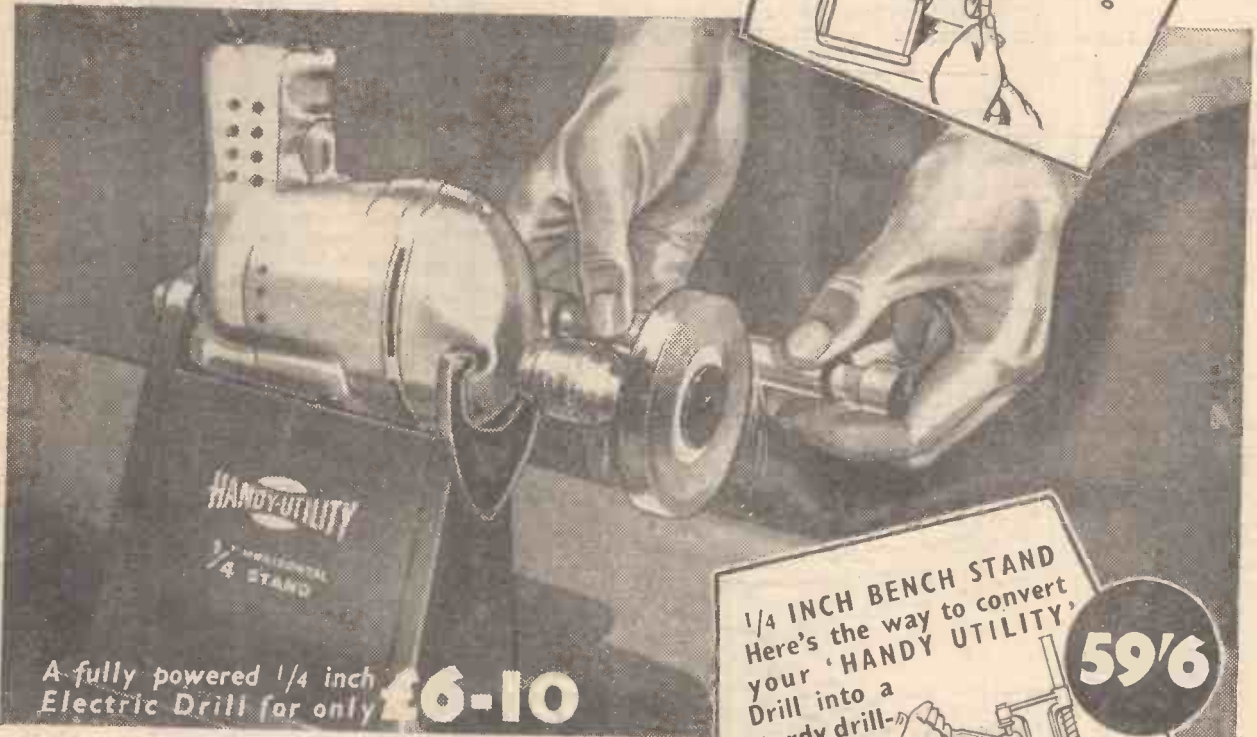

**17'6**  
**HORIZONTAL STAND**  
 for grinding and tool sharpening, buffing and polishing

A fully powered 1/4 inch Electric Drill for only **£6-10**

**59'6**  
**1/4 INCH BENCH STAND**  
 Here's the way to convert your 'HANDY UTILITY' Drill into a sturdy drill-press. You'll find plenty of jobs that demand a Bench Stand.

NOT just a drill but almost an electric workshop on its own—that's 'HANDY UTILITY,' the versatile power tool for faster, smoother, deeper drilling in steel, cast iron, brass . . . for easier drilling in wood, perspex, ceramics . . . for grinding, buffing and polishing metal parts . . . for cleaning off rust and old paint! Drilling capacity in steel 1/4 in.—in hardwood at least 1/2 in.

The mate of all work

**ELECTRIC**  
**HANDY-UTILITY**  
**TOOLS**

A PRODUCT OF BLACK & DECKER LTD.

**£11-15**  
**1/4 INCH DRILL KIT**  
 Drill, 13 h/s Bits, Horiz. Stand, Grinding Wheel, Wire Wheel Brush, Buff, Arbor, Metal Carrying Case.

**19'6**  
**ACCESSORY KIT**  
 Grinding Wheel, Wire Wheel Brush, Buff, Arbor, etc.



OBTAINABLE FROM YOUR LOCAL TOOL SHOP, IRONMONGER OR STORE

I have made some myself, and can certainly agree that it is a high-quality varnish. Wood ash can be prepared at home, the other ingredients can be obtained quite easily from a chemist or paint and colour merchant.—E. W. RICHARDSON (Bath).

#### "Hammered Silver" Effect

**S**IR,—In the December, 1950, issue F. H. Swingler (Gedling) describes a "hammered silver" finish which can be obtained by the use of a paint sprayer. A similar effect can be produced by using Fleetwood's hammered silver finish air-drying enamel, which gives a beautiful hammered effect with only one coat, and without using an undercoat. I have tried this paint and given it a

rigorous test against the weather, and it has stood it very well. Paint-spraying pressure, 40-45 lb. with the gun held 18in. to 22in. away from the object. Air-drying time is 4 to 6 hours.—K. A. BENNETT (St. Leonards-on-Sea).

#### Engraving on Glass

**S**IR,—May I add a few remarks to the information given to your Cardiff inquirer, C. E. Cleves.

In the process of glass engraving with the acid mentioned, laminated lead is laid over a surfacing of Russian tallow which firstly is spread upon the glass surface. The design to be etched is then cut out (of the laminated lead) and the appropriate sections removed,

exposing the glass to be etched. These areas are then cleaned with turpentine and the acid applied. If a wax dam is built around the edge of the glass the acid can be left until enough "bite" has been taken, and then (extremely carefully) poured off into a suitable container.

To effect different expressions in the "bite" place chippings or granules of mica on the glass before applying the acid.

Vegetable black is a "paint" used for outlining, etc., after the acid process has been completed; I think your correspondent is confusing Brunswick black with vegetable black. Brunswick black is used as a backing to the completed work.—A. WYNNE (Hungerford).

## Trade Notes

#### The "Bullfinch" Gas Torch

**T**HIS handy self-blowing gas torch has been placed on the market by Rainsford and Lynes, Ltd., Emily Street, Birmingham, 12. Connected to the normal gas supply, the torch, without compressed air, is capable of producing a flame temperature

priced at 65s., is 1½lb., and the diameter of the nozzle is 11/16in. A hose of 3/8in. bore is required for connection to the gas supply.

#### "Graphos" Indian Ink Fountain Pen

**A**NOTHER instrument for the use of draughtsmen is the "Graphos" Indian

#### Curvimeter Map-measurer

**M**ARKETED in this country by W. G. Pinner and Co., 1, York Road, Birmingham, 16, this well-known French instrument is recognised by civil engineers and surveyors as an outstanding map-measurer. By its use the draughtsman and mechanical engineer can reduce the solving of tedious calculations to one simple multiplication of the number of inches which the little wheel in his hand has travelled along complex lines, or around a contour and which can be read on the dial. The Curvimeter is made in two patterns; the BA54, a two-dial model with a large dial registering 0-48in.

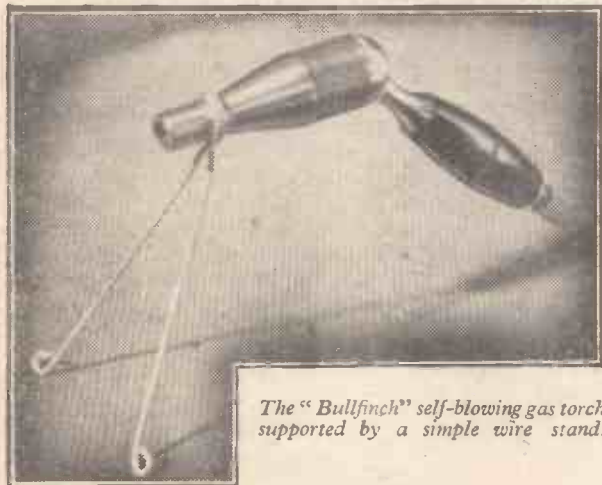

The "Bullfinch" self-blowing gas torch supported by a simple wire stand.

of 1,450° Centigrade (2,600° Fahrenheit). It is equally useful for brazing, silver soldering, forging small tools and many other workshop uses. For the plumber especially it is claimed to be superior to the ordinary blowlamp, as it gives a clean, smokeless flame. The weight of the torch, which is

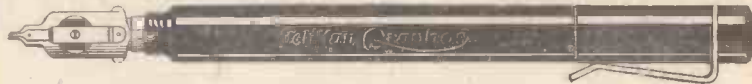

The "Graphos" Indian ink fountain pen.

ink fountain pen, which has been added to their range of drawing-office requisites by W. G. Pinner and Co., of Birmingham. This pen, which is the product of the makers of "Pelikan" drawing inks, requires only one easy filling instead of 50-100 filling manipulations of ordinary drawing pens. By the choice of nib the width of drawing lines is defined and exactly reproducible without variations through frequent refills. The pen is easily cleaned and can be refilled from either bottle or

cartridge. Various types of nibs are available for ruling fine or thick lines; tubular nibs for lettering with stencils; slant nibs for square end lines; round nibs for round end lines; and fine freehand drawing nibs. Further particulars are obtainable from the above firm.



This illustration shows the two-dial Curvimeter Map-measurer full size.

**Jewellers' and Watchmakers' Pocket Book.** Advisory Editor, A. Selwyn. Published by Heywood and Co., Ltd. 504 pages. Price 15s. net.

**T**HE object of this book is to present in convenient form information likely to be required by jewellers and watchmakers in their everyday work, in addition to providing a useful work of reference. The main sections of the book are grouped under five headings: Weights: Measures, Conversion Tables. Metals: Solders, Plating, Hall Marking. Gemstones: Cutting, Settings, Testing, etc. Horology: Weight, Spring, Electric Clocks, Watches. Commercial and Legal Information. In order to ensure that the information imparted in this pocket encyclopaedia is authoritative, the services of a number of specialist contributors were enlisted. In addition to numerous line

## Books Received

diagrams and half-tone illustrations, a very comprehensive technical index is included for facilitating quick reference.

**Engineering Metrology.** By K. J. Hume, B.Sc., A.M.I.Mech.E. Published by Macdonald and Co. (Publishers), Ltd. 294 pages. Price 18s. net.

**T**HIS book deals with the application of metrology in the field of mechanical engineering, and is intended to meet requirements of people engaged in industry, either directly or indirectly, and concerned with precision measurement in production, inspection and tool room or standards room work. The practical and theoretical aspects of engineering dimensional measurement are fully dealt with, and descriptions of typical

modern instruments, apparatus and methods have been included. The subject matter covers the metrology syllabuses of the A.M.I.Mech.E. and A.M.I.Prod.E. examinations, and should be of particular value to technical college students taking this subject in their Higher National Certificate course. The book is profusely illustrated in line and half-tone, and also contains a very full index.

## FOURTH EDITION. REFRESHER COURSE IN MATHEMATICS

By F. J. CAMM  
8/6, by post 9/-



# WIN SUCCESS IN LIFE

## Pelmanism Develops Your Latent Talents

IN this crowded world there are more good jobs looking for good people than good people looking for good jobs. For so few of us are ready for opportunity when it occurs.

Are you ready to grasp it, whether it is the chance of a more interesting and more remunerative post or a fuller and freer life in some other direction. Will you have the courage and clear-headedness to seize and use your chance?

Take up Pelmanism and prepare now for to-morrow's opportunities. You are then training, not only your mind, but your whole personality. Pelmanism rids you of handicaps which hold you back — be it self-consciousness, lack of initiative, fear or self-doubt or simply a tendency to worry about trifles.

Pelmanism also automatically develops your real self. Talents which you never knew you possessed come to the surface. For Pelmanism trains your mind and character just as physical exercise trains your body.

Remember—Everything you do is preceded by your attitude of mind.

The Pelman training for successful living has been proved by over 750,000 men and women of every type and calling. It is so clearly explained and carefully graded that anyone can follow it. It is modern psychology made practical.

Reduced fees for serving and ex-Service members of His Majesty's Forces. (Apply for Services Enrolment Form.)

The general effect of the training is to induce an attitude of mind and a personal efficiency favourable to the happy management of life.

### Send for Free Book

The Pelman Course is simple and interesting and takes up very little time. You can enrol on the most convenient terms. The Course is fully explained in "The Science of Success," which will be sent you, gratis and post free, on application to-day to:—

### PELMAN INSTITUTE,

130, Norfolk Mansions, Wigmore Street, London, W.1. Established over 50 years. Callers welcomed.

### POST THIS FREE COUPON TO-DAY

To the Pelman Institute, 130, Norfolk Mansions, Wigmore St., London, W.1. Please send me, gratis and post free, "The Science of Success"

Name .....

Address .....

PELMAN (OVERSEAS) INSTITUTES, PARIS: 176, Boulevard Haussmann. AMSTERDAM: Prinsengracht 1021. MELBOURNE: 386, Flinders Lane. JOHANNESBURG: P.O. Box 4928. DURBAN: Natal Bank Chambers (P.O. Box 1489). DELHI: 10, Alipore Road.

### DRAWING ARM

Designed for R.A.F. use as a plotter, but is ideal for all draughtsman's purposes. Includes a long metal rail for mounting at edge of drawing board, elbowed parallel arms, freely movable in all directions and a large protractor straight edge. The whole will give cover for a board 3ft. x 1ft. 9in., i.e., more than Imperial size. Tough tubular metal rods throughout. All moving parts. Lockable in all positions. Does the same work as a drawing machine of eight times the price. Special offer. (Post 22/6 and packing 1s. 6d.)

### MONSTER SPARES KIT

Biggest assortment of spare aircraft parts ever made available. Guar. to include four fine aircraft instruments, such as Air Speed Indic., R.P.M. Indicator, Rate of Climb Indic. Turn and Bank Gyro Indic. Electric Thermo., etc., plus miscell., parts of use to the model engineer. Large number of small gears, movements, syphon tubes and other movements of use to the amateur mechanic, experimenter, etc. Car. Pd. in U.K. only. 25/-

### SENSITIVE TACHOMETER

As fitted to all B. Aircraft, reading 0-5,000 r.p.m. and incorporates 4:1 gearbox. Also be used as 1:1. Outfit consists of flexible drive for connecting to crankshaft, motor, etc., 3-phase a.c. generator which should be connected by 3-core wire to the sensitive indicator. For large or small h.p. installation and complete with instructions. All instru. is tested before despatch, all made by leading British manufacturers, Smiths, Record, etc. Carr. paid. 45/-

### STUDENTS' DRAWING INSTRUMENT SETS

Each set in case contains spring-bow dividers, spring-bow compass, spring-bow combination pen-pencil compass large dividers, large combination compass and drawing pen. Draughtsmen's instruments of quality. Includes Regis. Post. 50/-

### DI-POLE AERIAL

Ex-Government television aerials, good working order, but require cleaning. Full size "H" type, 10ft. high, 5ft. wide with bracket for mounting on pole or against brick-work. Complete with 36ft. of co-axial cable; frame of heavy tubular metal construction. Also suitable for short-wave transmitting, etc. (Carriage paid.) 27/6

### AERO-SPARES CO. (Dept. 87)

70-71, High Holborn, London, W.C.1. Telephone: AMBassador 2871 2 (All depts.)

Most sizes available from stock!

# Bridges MICRO-DRILLS

STRAIGHT FLUTE DRILLS. A well-designed drill particularly recommended for drilling brass. Range of sizes: .35 mm. (.0138") to 3.0 mm. (.1181")

<h3>PIVOT DRILLS</h3> <p>Widely used by watch and clock making trades for drilling very small holes. Range of sizes: .05 mm. (.002") to .5 mm. (.0197")</p>	<h3>FLAT DRILLS</h3> <p>Similar to pivot drills but made in larger sizes. Range of sizes: .25 mm. (.0098") to 3.0 mm. (.1181")</p>
<h3>STANDARD SPIRAL FLUTE DRILLS</h3> <p>A general purpose drill of improved flute design for easy ejection of swarf. Range of sizes: .1 mm. (.0039") to 3.0 mm. (.1181")</p>	<h3>SINGLE SPIRAL FLUTE DRILLS</h3> <p>For drilling small holes to extremely fine limits. Range of sizes: .1 mm. (.0039") to 3.0 mm. (.1181")</p>

## WRITE FOR STOCK LIST

S. N. BRIDGES & CO. LTD.

Bridges Place, Parsons Green Lane, London, S.W.6.

# GALPIN'S

ELECTRICAL STORES

408, HIGH STREET, LEWISHAM LONDON, S.E.13.

Tel.: Lee Green 0309. Nr. Lewisham Hospital. Terms: Cash With Order. No C.O.D. Early Closing Day Thursday. All Goods sent on 7 days' approval against cash.

**MAINS BOOSTER TRANSFORMERS.** 1,500 watts tapped 0, 6, 10, 19, 175, 200, 225, 240 and 250 volts, good condition, electrically guaranteed, £41/5/- each. Carriage 5/-.

**HIGH CYCLE ROTARY CONVERTERS.** 24 volts D.C. Input 100 volts, 3 phase, 400 cycles, approx. 60 watts output, as new, 35/- each. Carriage 3/6.

**DOUBLE WOUND 3,000 WATT VOLTAGE CHANGER TRANSFORMERS.** 130 to 250 volts or vice versa, weight 100 lbs., £10 each. Carriage 10/-.

**SWITCH-BOARD METERS.** 4in. scale 0 to 14 amp. D.C., 17/6 each. 0 to 30 amp. AC/DC, 22/6. 0 to 14 amps. AC/DC, 22/6 each. All fully guaranteed.

**MAINS TRANSFORMERS (New).** all 200/250 volt primaries in steps of 10 volts. Output 350/350 volts, 450 m/a., 6.3 v. 8 a., 6.3 v., 8 a., 4 v. 4 a., 5 v. 4 a., 62/6 each; 500/1500 volts 300 m/a., 6.3 v. 8 a., 6.3 v. 8 a., 4 v. 4 a., 5 v. 4 a., 62/6 each; 500/1500 volts, 300 m/a., 6.3 v. 8 a., 6.3 v. 8 a., 6.3 v. 4 a., 5 v. 4 a., 3 v. 4 a., 67/6 each; 350/1350 volts, 250 m/a., 6.3 v. 8 a., 4 v. 8 a., 4 v. 4 a., 6.3 tapped 2 v. 2 amps. (Electronic), 57/6 each. Carr. 3/6.

**MAINS TRANSFORMERS (New).** all with 200/250 volt primaries in steps of 10 volts; output 350/1350 volts, 180 m/a., 6.3 v. 8 a., 5 v. 3 a., 37/6 each; 350/1350 volts, 180 m/a., 6.3 v. 4 a., 5 v. 3 a., 4 v. 4 a., 37/6 each; 500/1500 volts, 150 m/a., 6.3 v. 4 a., 4 v. 4 a., 5 v. 3 a., 42/6 each; 425/1425 volts, 160 m/a., 6.3 v. 3 a., 6.3 v. 3 a., 5.3 a., 39/6 each. Carriage extra 1/6.

**MAINS TRANSFORMERS.** 230 volts, 50 cys., 1 ph. input, tapped output, 0, 6, 12, 18 volts at 4 amps., at 17/6 each, post 1/6; another 230 volt input, 700/1700 volt, 70 m/a., 12 v. 1 a., 4 v. 2 1/2 a., 27/6 each, post 1/6.

**METERS EX-W.D. SURPLUS (New).** 2in. scale, moving coil 0 to 20 volts, 6/- each, post 9d.; another 0 to 40 volts, 7/6 each, post 9d.; another 0 to 10 amp., 12/6 each, post 9d.

**DUCOIN VARIABLE TARIFF ELECTRIC LIGHT Id./Is. SLOT METERS,** all fully guaranteed 200/250 volt A.C. mains 5 amp. load, 42/6 each, carriage 2/6; 20 amp. load, 57/6 each, carriage 2/6.

**SMALL SIZE CREDIT TYPE ELECTRIC METERS,** 200/250 volt A.C. mains, overall size 4 1/2 in. x 3 1/2 in. x 3 1/2 in., weight 4 lbs., 10 amp. load, 35/-, post 1/-; 20 amp. load, 30/-, post 1/-; 25 amp. load, 35/-, post 1/-, fully guaranteed electrically.

**BRIDGE MEGGERS,** by well-known makers, 250 volt type, complete in leather carrying case, as new, £12/10/0 each, carriage and packing 7/6.

**ROTARY CONVERTERS,** 24 volts D.C. input, 50 volts 50 cycles, 1 ph. at 450 watts output, complete with step-up transformer from 0 to 230 volts, £7/10/0 each, carriage 10/-, condition as new.

**ROTARY CONVERTERS, EX-NAVAL,** well-known makers, 100 volts D.C. input, 230 volts 50 cys., 1 phase at 250 watts output, capable of 100 per cent. overload, weight 100 lbs., condition as new, £10/10/0 each, carr. paid.

**POWER TRANSFORMER AUTO WOUND,** voltage changer tapped 0, 110, 150, 180 and 230 volts at 1,600 watts, £5/5/0 each, carriage 3/6; ditto, 2,000 watts, £6/5/0 each, carriage 3/6; another tapped 0, 110, 200, 230 volts at 350 watts, at 48/6 each, carriage 2/6.

**EX-R.A.F. MICROPHONE TESTERS.** These contain a 2 1/2 in. scale 0 to 450 micro-amp. meter shunted to 1 m/a., calibrated 0 to 10 volts, moving coil, complete with 1 m/a. rectifier, "mike transformer," etc., all contained in polished wood box, as new, 17/6 each.

**ELECTRIC LIGHT CHECK METERS,** quarterly type, for sub-letting garages, apartments, etc., all fully guaranteed electrically for 200/250 volts A.C. mains, 50 cys., 1 ph., 5 amp. load, 17/6 each; 10 amp. load, 20/-; 20 amp. load, 25/- each, 50 amp. load, 37/6 each; carriage 2/- extra on each; special discount of 10 per cent. on quantities of one dozen or more.

**MAINS TRANSFORMERS (New).** All 200/250 volts input in steps of 10 volts. Outputs, 0, 6, 12 and 24 volts at 10/12 amps., 47/- each; 0, 18, 30, 36 volts at 5/6 amps., 42/6 each; 0, 6, 12 and 24 volts at 25/30 amps., 68/6 each; 0, 6, 12 and 24 volts at 5/6 amps., 35/- each.

**ENLARGERS** up to 2½in.  
**EPISCOPES**  
**TELESCOPES**  
**BINOCULARS**  
**RIFLE SIGHTS**  
**EPIDIASCOPES**  
**FILM STRIP**  
**PROJECTORS**  
**PROJECTION LENS**  
**CONDENSERS** up to 2½in.  
**MICROSCOPES**  
**STEREOSCOPES**  
**MAGIC LANTERNS**

If you are interested in making any of the above then you are badly in need of our new booklet "How to use ex-Govt. Lens and Prisms" price 2/6 each. We hold a large and varied stock of ex-Govt. lens and prisms and general optical gear. New and enlarged lists free on receipt of your S.A.E.

## H. ENGLISH

Rayleigh Road, Hutton, Brentwood, Essex  
 Phone: Brentwood 1685

### Announcing "LINESIDE" KITS

"00" Gauge

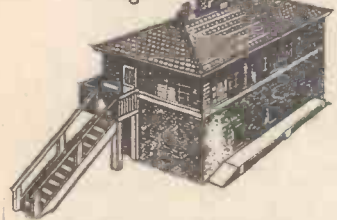

### for Railway Modellers

These kits are ideal for the man who would like to find out just where the fascination lies in scenic railway modelling for they enable him to make a start on a simple but satisfying job at small expense. They contain printed card and wood parts, printed celluloid windows, detailed authentic plans, brick and tile building papers. The first off are

- LARGE SIGNAL CABIN.....3/8
- WATER TOWERS (2 types in 1 kit) 2/9
- COUNTRY STATION.....5/6
- LARGE GOODS STATION.....3/8

Postage: Single kit 6d., two or more 10d.

★ **The full MODEL CRAFT LIST for 1951** gives details of more than 600 plans, planbooks, kits and accessories covering every aspect of the model-maker's art, ships, aircraft, road vehicles, houses, etc. It costs 1/- post free and includes a 1/- refund voucher for use in buying Modelcraft goods.

**Modelcraft Ltd**  
 7(L), Grosvenor Rd., London, S.W.1

STUDY AT HOME

IN YOUR SPARE TIME

# THE BENNETT COLLEGE

*will set you on the right course for success*

You make sure of planned progress in the career of your choice when you let the most progressive, most successful Correspondence College in the world coach you through the post. By friendly, individual training we equip you with the specialised knowledge you must have for a well-paid, key position. Make the first move TO-DAY—post the coupon below!

**ALL TEXT BOOKS ARE FREE!**

We send you as many volumes as the subject chosen demands, and they become your personal property.



## IS YOUR CAREER HERE? IF NOT, WRITE FOR FREE ADVICE

Accountancy Examinations  
 Agriculture  
 A.M.I. Fire E. Examination  
 Applied Mechanics  
 Auctioneers and Estate Agents  
 Aviation (Engineering and Wireless)  
 Blue Prints  
 Boilers  
 Book-keeping, Accountancy and Modern Business Methods  
 Builders' Quantities  
 Building, Architecture and Clerk of Works (A.R.I.B.A. Exams.)  
 Carpentry and Joinery  
 Chemistry  
 Civil Engineering  
 Civil Service  
 All Commercial Subjects  
 Commercial Art  
 Common Prelim. E.J.E.B.  
 Concrete and Structural Engineering  
 Diesel Engines  
 Draughtsmanship  
 Electrical or Mechanical Engineering, all Branches, Subjects and Examinations  
 General Certificate of Education Examinations  
 General Education  
 G.P.O. Eng. Dept.  
 Heating and Ventilating  
 Institute of Housing  
 Institute of Municipal Engineers  
 Journalism  
 Languages  
 Mathematics  
 Metallurgy

Mining, all Subjects  
 Mining, Electrical Engineering  
 Motor Engineering  
 Naval Architecture  
 Novel Writing  
 Plastics  
 Play Writing  
 Plumbing  
 Police, Special Course  
 Preceptors, College of  
 Press Tool Work  
 Pumps and Pumping Machinery  
 Quantity Surveying—Institute of Quantity Surveyors Exams.  
 Radio Service Engineering  
 Radio (Short Wave)  
 Road Making and Maintenance  
 Salesmanship  
 Sanitation  
 School Attendance Officer  
 Secretarial Examinations  
 Sheet Metal Work  
 Shipbuilding  
 Shorthand (Pitman's)  
 Short Story Writing  
 Social Welfare  
 Structural Engineering  
 Surveying (R.I.C.S. Exams.)  
 Teachers of Handicrafts  
 Telecommunications (City and Guilds)  
 Television  
 Transport Inst. Examinations  
 Viewers, Gaugers, Inspectors  
 Weights and Measures Inspectors  
 Wireless Telegraphy and Telephony  
 Works Managers

**COUPON. CUT THIS OUT**  
 IF YOU ATTEND TO THIS NOW IT MAY MAKE A WONDERFUL DIFFERENCE TO YOUR FUTURE

**TO DEPT. 76, THE BENNETT COLLEGE LTD.**  
**SHEFFIELD, ENGLAND.**

Please send me (free of charge) particulars of.....

Your private advice about.....

(Cross out line which does not apply)

PLEASE WRITE IN BLOCK LETTERS

NAME.....

ADDRESS.....



## MIDLAND INSTRUMENT CO.

For Govt. Surplus Stock, Etc.

**MOTOR BLOWERS**, identical to those described in Feb. issue P.M., for constructing a Hand Vacuum Cleaner, 80 v. amp., requires 150 watt lamp, etc., series resistor to run from 200/250 v. A.C. mains, condition as new, 12/6, post 1/3. **MAINS TRANSFORMERS**, multiple L.T., input 200-220-240 v. 1 phase 50 cycles output tappings giving 3, 4, 5, 6, 8, 9, 10, 12, 15, 16, 20, 24, 30 v. at 2 amps. a superior transformer, new boxed, 20/-, post 1/3. **LONDEX RELAYS**, 9-12 v. 2 pole make contacts, new unused, 2/6, post 4d. 24/- doz., post 1/-. **BELL WIRE**, twin twisted 0.20 tinned copper, covered red/blue, suitable for telephones, extension speakers, etc., etc., 50 yd. coils, 3/-, post 6d. 440 yd. coils, 22/6, post 1/6. **MOTOR GENERATORS, TYPE 72**, can be converted to an efficient 200 v. A.C. mains motor, suitable for sewing machines, polishing, etc., etc., takes approx. 1 amp., fitted 3/16in. shaft, standard base mounting, new, unused with conversion data, 15/-, post 1/3. **VEEDER METERS**, plated case enclosed pattern, 0-9999, 5/-, post 3d. **UNIVERSAL JOINTS**, for coupling 5/32in. shafts, length 1½in., 1in. dia., superior job, 1/6, post 3d. 15/- doz., post 6d. Allen keys to fit set screws for above couplers, 2d. extra. **METERS**, 25-0-25 amps., projection fitting, 2½in. dia., new boxed, 5/-, post 6d. **CRYSTAL RECTIFIERS**, CV-102, the ideal crystal set permanent detector, new in lead capsules, 3/6, post 3d. **MOTOR GENERATORS, TYPE 34**, 3-commutator P.M. field, input 24 v. 1.7 amp., output 6.3 v. at 2 amp. also 200 v. at 30 mA, also suitable for 6 or 200 v. input at corresponding voltage output, new unused in metal cases with other incidentals, bargain, 5/-, post 1/6. **MOVING COIL HEADPHONES**, together with attached moving coil microphone, special offer, 7/6, post 1/-. **CAR LAMPS**, S.B.C. fitting, double contact, twin filament, 12 v. 5 plus 24 watt, new boxed, 1/-, post 3d. 10/- doz., post 10d. Ditto, 24 plus 24 watt, same price. **MICRO-AMMETERS**, 0-100, 2½in. scale, flush panel mts., fitted damping short, new boxed, 30/-, post 6d. **VOLTMETERS**, 100 v. A.C., moving coil with internal instrument rectifier (basic movement 1 mA), 2½in. scale, flush panel mts., new boxed, 20/-, post 6d. Send s.a.e. for current 20-page lists.

**MOORPOOL CIRCLE,**  
**BIRMINGHAM, 17**  
 Tel.: HARborne 1308 or 2684

### Valves

**Rectifier, type VU133 (CV1133)**, half wave, indirectly heated cathode, 4 volts, 1.35 amp., max. A.C. plate volts 2,500, D.C. output current 60 m.a., peak inverse volts 7,000, peak plate current 400 m.a. Top cap anode. Price 4/6 each. Post and packing, 3d.  
**Rectifier, type 5U4G**, full wave, 5 volt, 3 amp. filament. Max. A.C. plate volts 500, D.C. output current 250 m.a., peak inverse volts 1,400, octal base. Price 7/6. Postage and packing, 3d.  
**H.F. Pentode SP41**, Price 3/6 each. Postage and packing 3d. All valves are guaranteed and tested before despatch.

### Goggles

Brand new, boxed tinted goggles: edges fur lined and complete with elastic strap; large lenses for wide angle viewing. Price 8/6 each. Postage and packing, 6d.

### Meters

**Ammeters**, 0-9 amps.; A.C./D.C. hot wire, in 2 amp. divisions; 3½in. diameter panel mounting. Brand new; boxed; 6/- each. Packing and postage, 3d.

### Ensura-Lite Chargers

Made by Ediswan, consisting of a steel cabinet, 17½in. by 10in., complete with carrying handles; for 20-250 volt C. operation, the output is 12 volts at 5 amps., and the unit is complete with ammeter, tungar rectifier, switching, fuses, etc., ready for operation. This unit was designed for providing an emergency automatic lighting supply in the event of power cuts or mains failure. A relay circuit automatically brings in the emergency battery lighting in the event of the A.C. supply failing. Provision is also made for trickle charging at 80 mA. A space is provided inside the cabinet for a 12 volt accumulator, making the whole unit self-contained. Apart from its original use, this could be used quite satisfactorily as an ordinary charging unit. Price 24/10/0 each, carriage paid.

Send S.A.E. for our Super Detailed List

**WILFLO PRODUCTS**  
 216-222, GORBALS STREET  
 GLASGOW, C.5

# QUERIES and ENQUIRIES

A stamped, addressed envelope, three penny stamps, and the query coupon from the current issue, which appears on page 48 (THE CYCLIST), must be enclosed with every letter containing a query. Every query and drawing which is sent must bear the name and address of the reader. Send your queries to the Editor, PRACTICAL MECHANICS, Geo. Newnes, Ltd., Tower House, Southampton Street, Strand, London, W.C.2.

## Colouring Cement for Paths

I INTEND to lay a number of "crazy paving" paths, using different coloured cement. Could you inform me of the materials used and where they can be obtained to colour the cement as follows: Red, green, brown, yellow, black and white? The mixture would be poured into moulds on the paths to a depth of about 1/4 in. When the cement is dry the mould would be used somewhere else.—A. D. J. Bullock (Wednesbury).

YOU can colour the cement by mixing with it (before the addition of water) about 20 per cent. of its bulk of any dry pigment. To this end, you may have to decrease the proportion of "fines" in the cement mix, because the pigment itself will act, also, as a fine filler.

Only very enduring pigments can be used in cement mixes, since many pigments cannot withstand the alkalinity of the cement, nor the action of light and other agencies.

We would suggest the following pigments for your use, all of them being permanent and light-fast:—  
Red: high-grade red iron oxide.  
Green: chromium oxide. (This is the only available fast green.)

Black: drop black (with or without admixture of manganese dioxide and carbon black).  
White: 50:50 mixture of titanium oxide and barytes. (Do not add any blue to "improve" the white. This practice tends to greyness of the whites.)  
Yellow: yellow ochre. (Cadmium yellow gives a stronger colour, but is much more expensive and less durable.)

Brown: Burnt sienna with a little umber, and, possibly, a very slight trace of black. (For dark brown, use umber alone.)  
All the above dry pigments can be obtained from any colour or decorator's shop, except, possibly, titanium oxide ("titanium white"), which can be obtained in small lots from Anchor Chemical Co., Ltd., Clayton, Manchester, 11. The price is around 1s. 6d. lb. Barytes can be obtained from Messrs. A. M. MacCarthy, 36, Sandford Road, Moseley, Birmingham, 13.

## Hydrated Copper Carbonate

WILL you please give me the modern names for: 1. Bitartrate of potassium; 2. Carbonate of potash; 3. Wet hydrated carbonate of copper; 4. Sweet oil? How is wet hydrated carbonate of copper made?—T. C. Pearson (Southsea).

THE correct names for the materials which you list are:—

Potassium bitartrate (frequently called "Cream of Tartar").

Potassium carbonate (sometimes, but not always, called "potash").

Copper carbonate.

Olive oil.

In connection with the last-named substance, the term "Sweet oil" is very loosely applied. Sometimes it designates olive oil and mixtures thereof. At other times sweet almond oil is designated.

The expression "wet hydrated" is almost meaningless when applied to a material. What we think is indicated here is the hydrated copper carbonate  $CuCO_3 \cdot Cu(OH)_2$ , which is found as the green mineral malachite. This is the hydrated carbonate of copper. It can be obtained artificially when a solution of sodium carbonate is added to a solution of copper sulphate. Under these conditions, the hydrated copper carbonate will be precipitated, and since it will have water clinging to it, we suppose that one would be entitled to call it in this condition a wet hydrated carbonate of copper. After this insoluble material has been washed and dried, it would still be a hydrated copper carbonate, but no longer a wet one. The term "hydrated" merely refers to the elements of water being held in chemical union with the substance.

## Solid Deodoriser

CAN you inform me if it is possible to make a good deodoriser cheaply? I want something that can be made in liquid form but that will set hard when cold. Also where can I get supplies of the necessary ingredients?—E. Wright (Barrup-in-Furness).

YOU do not say for what purpose you wish to use the deodoriser. There are many types of deodorisers, each having a special purpose. Some are specially perfumed; others are not so treated.

A good solid deodoriser can be made by gently melting down together about equal quantities of white naphthalene (moth balls) and para-dichlorobenzene. You will be able to obtain the latter from any chemical merchant in your district, or from Messrs. James Beard & Co., Ltd., 16, Great Ancoats Street, Manchester, or Messrs. Vicsons Ltd., 148, Pinner Road, Harrow, Middx.

## Dope for Model Aeroplanes

CAN you give me a formula for making a shrinking dope for model aeroplanes? I have a quantity of clear cellulose lacquer and believe that by adding something to it this will shrink the paper.—H. Pasco (Wirral).

THE so-called "shrinking" dope for model aeroplanes is merely a solution of scrap celluloid in a mixture of approximately equal parts of amyl acetate and acetone. This is brushed on to the material and allowed to dry. The celluloid solution enters into the fibres of the material and stiffens them, thus effecting an apparent shrinkage.

In place of the above preparation, you can use a preparation made by dissolving 15 parts of polyvinyl acetate resin in 85 parts of warm methylated spirit. This resin (under the name of Gelva Resin, No. 7) can be obtained from Shawinigan, Ltd., Marlow House, Lloyd's Avenue, London, E.C.3. Price about 5s. lb.

Readers are asked to note that we have discontinued our electrical query service. Replies that appear in these pages from time to time are old ones and are published as being of general interest. Will readers requiring information on other subjects please be as brief as possible with their enquiries.

## Polishing Ebonite

COULD you please inform me of a method whereby I can polish sheet ebonite, particularly the edges? I am making a multi-range meter and wish to make a box of ebonite panels.—W. L. Crocker (Walkhampton).

IT is not easy to bring ebonite to a high polish, particularly when dealing with articles which cannot be revolved in a lathe. However, the essence of the

polishing process is to get the finest possible surface on the ebonite by means of several grades of emery cloth, finishing up with two or three fine grades of glasspaper. After this, the surface is rubbed down with putty powder, the power being sprinkled on an oily piece of flannel or thick cloth and applied with vigour to the ebonite surface. Finally, it is rubbed down with fine whiting applied to a piece of soft leather.

The surface thus obtained can be given a rubbing over with wax polish or with shellac polish. Alternatively, it can be lacquered with a clear, transparent lacquer, applying one or more coats. Unless a very lustrous surface is required, shellac or lacquer treatment will be unnecessary, but a wax treatment is often desirable on account of the richness which it imparts to the black surface.

## Wood Naphtha

PLEASE inform me if commercial wood naphtha is the same liquid as wood alcohol which is used as an embrocation for the skin. Also, what will deodorise wood naphtha, and to what extent may wood naphtha be used in making shellac varnish?—F. O'Driscoll (Ballina, Co. Mayo).

WOOD naphtha is an impure form of wood alcohol, which latter consists chiefly of methyl alcohol. It is the latter liquid which is usually employed for embrocations. It must always be remembered that methyl alcohol in its various commercial forms is poisonous to drink because it gives rise to formic acid in the body.

No single substance will deodorise wood naphtha, but an excellent deodoriser for the purpose is made by Crepin & Doumin, Ltd., 15, Cooper's Way, Crutched Friars, London, E.C.3. You will also be able to obtain a similar product from Messrs. W. J. Bush & Co., Ltd., Ash Grove, Hackney, London, E.8.

You can incorporate wood naphtha (1 part) with about 2 parts of methylated spirit in making shellac varnish. If you add more, the varnish becomes too volatile and dries too quickly.

## Marble Powder Mixture for Moulding

I HAVE at my disposal large quantities of pulverised white marble (powder form). I have been experimenting with this with the object of trying to produce objects from flexible moulds that can be polished to look like white marble when finished. I have tried mixing white cement and other binders, but without success.

Can you help me out in this, and let me know what could be mixed with pulverised marble to achieve the result as stated above? Also, can you let me have a formula for liquid marble?—W. Sedwards (Galway, Eire).

THE characteristic appearance of marble depends upon its colourations and its glass-like polished surface. When you powder marble, you destroy both these characteristics, and, thereafter, no amount of re-constituting or mixing the marble powder with other binding materials can restore the original appearance of the marble.

The best thing you can do is to mix intimately equal parts of Portland cement and powdered marble. Slake this with water, and then allow it to set. The product will have a rough surface. It can, however, be semi-polished by means of an abrasive powder and water. You will never, however, obtain the true marble surface, simply because the continuity of the original marble surface has been broken up and cannot be restored.

Strictly speaking, there is no such thing as "liquid marble". The name has been applied (quite wrongly) to a variety of compositions similar to the above mixture of cement and marble dust when slaked with water. Certain paints, too, have been made up with marble dust—paints essentially consisting of sodium-silicate solutions which are heat-resisting. All these fanciful names, however, mean simply nothing.

If you want to experiment, try the following: Dissolve 3.5 parts (by weight) of ammonium aluminium sulphate in 1 part (by wt.) of water. Dissolve by heat. Mix the liquid to the condition of a slurry with talc, marble dust or plaster of Paris (or with a mixture of these). Pack into mould to set. The resulting product will set with a certain amount of surface sheen. Hence the title of "liquid marble" which is sometimes applied to the wet product.

## Compressing Carbon Dioxide

I WISH to compress carbon dioxide gas in a tank to a pressure of 80-120 lb./sq. in., and I intend to take it from a standard cylinder. I have a pressure-tank with a motor, etc.

Will a mixture of carbon dioxide and air compressed cause any trouble? Also, how can I reuse the gas after use instead of just letting it escape into the atmosphere? Can I take it back from the pressure tank, and if so, what will I require to do so?—J. R. Ford (Stratford).

THERE will be no special trouble in compressing a mixture of carbon dioxide and air. Carbon dioxide is quite incombustible, so that there will not arise any danger of ignition of the gas mixture on compression.

The question of reusing the carbon dioxide after it has once been used depends to some extent on the exact use which you propose to make of it in the first place. We presume that the gas will remain perfectly dry and uncontaminated, in which case you will require a second cylinder or pressure tank fitted with a one-way charging valve. The waste gas will have to be compressed into the tank or cylinder by means of a separate pump. It

## THE P.M. BLUEPRINT SERVICE

12FT. ALL-WOOD CANOE. \*New Series. No. 1  
3s. 6d.

10-WATT MOTOR. New Series. \* No. 2. 3s. 6d.  
COMPRESSED-AIR MODEL AERO ENGINE.\*  
New Series. No. 3. 5s.

AIR RESERVOIR FOR COMPRESSED-AIR  
AERO ENGINE. New Series. No. 3a. 1s.  
"SPORTS" PEDAL CAR.\*New Series. No. 4. 5s.  
F. J. CAMM'S FLASH STEAM PLANT.\* New  
Series. No. 5. 5s.

SYNCHRONOUS ELECTRIC CLOCK. New  
Series. No. 6. 5s.\*

ELECTRIC DOOR-BELL. No. 7. 3s. 6d.  
ASTRONOMICAL TELESCOPE. New Series.  
No. 8 (2 sheets). 7s.\*

CANVAS CANOE. New Series. No. 9. 3s. 6d.  
DIASCOPE. New Series. No. 10. 3s. 6d.  
EPISCOPE. New Series. No. 11. 3s. 6d.\*

PANTOGRAPH. New Series. No. 12. 1s. 6d.\*  
COMPRESSED-AIR PAINT SPRAYING  
PLANT. New Series. No. 13. 7s. 6d.\*

£20 CAR\*  
(Designed by F. J. CAMM).  
10s. 6d. per set of four sheets.

MASTER BATTERY CLOCK  
Blueprints (2 sheets), 3s. 6d.  
Art board dial for above clock, 1s.

OUTBOARD SPEEDBOAT  
10s. 6d. per set of three sheets.

SUPER-DURATION BIPLANE  
Full-size blueprint, 2s.

The 1-c.c. TWO-STROKE PETROL ENGINE  
Complete set, 7s. 6d.

STREAMLINED WAKEFIELD  
MONOPLANE — 3s. 6d.

LIGHTWEIGHT MODEL MONOPLANE  
Full-size blueprint, 3s. 6d.

P.M. TRAILER CARAVAN  
Complete set, 10s. 6d.

P.M. BATTERY SLAVE CLOCK\*—2s.

The above blueprints are obtainable, post free,  
from Messrs. George Newnes, Ltd., Tower House,  
Southampton Street, Strand, W.C.2.

An \* denotes constructional details are available, free,  
with the blueprints.

will not do merely to connect the one pressure tank with a second one in the expectation that the gas will flow out of the one tank into the other.

The whole arrangement, however, necessarily depends on what use you are making of the gas or gas-mixture, and, in the absence of this information, we are afraid that we cannot give you all the advice which you ask for. Carbon dioxide is fairly cheap, so much so that if you are only going to use relatively small quantities of it we doubt whether it would be worth your while to go to the expense and trouble of providing for its recompression and storage.

**Sealing Spirit-level Tubes**

**CAN** you inform me how the end of a spirit-level tube is sealed off after filling? In my experiments the liquid gasifies and blows through when the tube is hot enough for sealing.—S. Thompson (Sutton Coldfield).

In most commercial processes of spirit-tube making the spirit is very strongly cooled in the tube by dipping the latter in solid carbon dioxide ("carbonic acid snow") or some other refrigerant. The nipple of the tube is then quickly sealed by passing it through a small but very hot flame.

Since you will be working on a small scale, you would be advised to utilise the small flame of a gas blowpipe, or even a petrol or paraffin blowlamp, and to dip the tubes for a minute or two in a mixture of ice and water before sealing. The separate tubes are wiped quite dry on the outside, and are held lightly in a pair of forceps while they are passed rapidly through a small blowlamp flame. This will seal the glass before the spirit has had time to heat up and to develop a vapour pressure sufficient to blow through the softened glass.

We assume, of course, that you are using the usual soda glass, which is employed for laboratory tubing on account of its low melting-point.

**Simple Hygrometer; Beeswax Polish; Oxygenating Aquarium Water**

SOME time ago in "Practical Mechanics" you gave a formula for soaking paper to make a simple hygrometer. Would you kindly repeat this formula and also state what kind of paper should be used? About how long will the treated paper be effective?

Could you also suggest a good recipe for a beeswax polish?

In my aquarium I am troubled with algae. Is there anything I could put in the water to kill these minute plants? Is there any other way of oxygenating the water apart from using plants or a pump?—E. J. Harmsworth (London, N.).

A SIMPLE hygrometer can be made by soaking white blotting paper in the following solution:—

- Cobalt chloride . . . . . 1 oz.
- Common salt . . . . . 1 oz.
- Gelatine powder . . . . . 15 grains

The paper is then hung up to dry in a warm room. When perfectly dry, its colour will be blue. When very moist, it will be rose-red.

The rough humidity indications which it will give are:—

- Rose-red . . . . . Moisture-saturated.
- Pale red . . . . . Very moist.
- Bluish-red . . . . . Moist.
- Lavender-blue . . . . . Nearly dry.
- Blue . . . . . Very dry.

These colour changes are reversible, and the paper will last almost indefinitely in working condition, provided that it does not become dirty, greasy or oil-contaminated.

You can make a simple beeswax polish by dissolving beeswax in an equal weight of turpentine or in a mixture of genuine turpentine and white spirit. This gives a good polish on woodwork, but because beeswax is relatively soft, the polish is apt to fingermark.

A better polish is made by using a 50 : 50 mixture of beeswax and Yellow Carnauba wax. These two waxes are gently melted together and about 1½ times their bulk of turpentine (or turps-white spirit mixture) is slowly added. The mixture is well stirred. It may be dyed by the addition of a little oil-soluble dye, and perfumed by adding a few drops of a strong perfume liquid, such as pine essence.

The mixture should be poured out into tins before it solidifies. It will be very economical to use. If too thick for your liking, re-melt it, and add some more of the turps. The addition of some pure D.D.T. to the molten polish will render it fatal to any insect which walks across a polished surface.

The whole of your aquarium troubles seem to be due to the fact that the water has not become adequately "balanced." You do not tell us what type of aquarium you have, but there is certainly no method of oxygenating the water therein other than by splash-agitation (the fountain method) or by the use of plants.

We would advise you to stock the aquarium up with oxygenating plants, and also to keep at least half a dozen water-snails in it. Snails are great scavengers and will quickly deal with algae and cloudiness. You can also treat the algae trouble by adding a little copper sulphate to the water (not more than 1 part in 10,000), but if you have living creatures and fish in the tank, we do not advise this course of action. Rely on the snails and plants and the agitation of the water. The aquarium will then soon become "balanced."

**Watermark Detector**

**I WISH** to make a watermark detector for stamp-collecting. I believe that the stamp, illuminated from behind, is viewed through a piece of filter glass. Can you please give me particulars of this glass? Can I make it at home or where can I buy it?—W. E. Round (Bristol).

THE "filter" type of watermark detectors are not universally successful, although they give very good results in some instances. The principle involved is to view the stamp (illuminated by strong transmitted light) through a glass or gelatine film filter of approximately the same colour as the body of the stamp. In this way, the details on the stamp surface are minimised and the watermark shows through more clearly. You would, therefore, view a red stamp through a red filter or glass, a blue stamp through blue glass, and so on. You need not use glass for the purpose. From Ilford, Ltd., Ilford, London, you can obtain dyed gelatine visual filters (i.e., the gelatine film only), so that, for a few shillings, you can acquire an assortment of different filters. Naturally, the presence of heavy postcards hampers this mode of watermark detection very greatly, which is one of the reasons why the system is not universally acceptable. If this type of detector can be purchased anywhere in this country, it will be available at Messrs. Stanley Gibbons, Ltd., Strand, London, W.C.2.

**Rewinding a Small Motor**

**I WISH** to rewind a small "Universal" motor to run off 240-volt, 50-cycle mains. According to the maker's plate, the motor is rated at 1/16 h.p., and is designed to work a small grinding wheel.

I should be grateful if you can advise me as to the number of turns and wire gauge of the windings.

I enclose a rough sketch of the field magnet. The armature is 1½ in. in length and has 12 slots 9/32 in. deep; there are 24 commutator segments; the air-gap clearance between the armature and field poles is 1/64 in.—T. H. Clinton (Bushey).

WE suggest that you wind each pole of the field magnets with 400 turns of 31 s.w.g. enamelled wire, the two coils being connected in series with each other so as to create poles of opposite magnetic polarity, and in series with the armature.

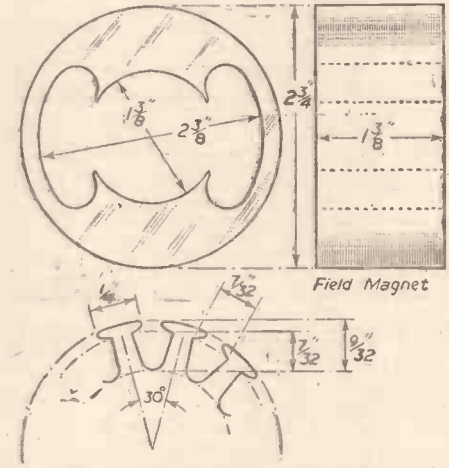

Field magnet and armature for a small motor.

The armature could have 12 coils, each with 120 turns of 38 s.w.g. D.S.C. wire, a loop being brought out from the centre of each coil for connection to the commutator. Use a coil span from slots 1 to 6, etc. With the armature placed so that slots 1 and 6 are equidistant from the centre of one pole face, number the commutator segment which then lies under the nearest brush, Number 2. All numbering is considered clockwise at the commutator end.

For clockwise rotation at the commutator end connect the start of the coil in slots 1 and 6 to commutator segment 3, the loop to segment 4, and finish of the coil to segment 6. Connect the start of the coil in slots 2 and 7 to segment 6, loop to 7, finish of the coil to segment 8, and so on. For counter-clockwise rotation at the commutator end, subtract four from the numbers of the segments quoted above for the coil connections.

**Renovating an Asphalt Path**

**CAN** you inform me how to renovate an asphalt path? Is it possible to float a concrete layer successfully or, if not, could bitumen and granite chippings be used?—C. Johnson (Manchester).

THE mode of renovation of an asphalt path depends altogether on how far the path in question has been damaged or subjected to wear. If the path has developed a few small holes or two or three larger ones, it may be repaired merely by filling up the holes with mastic asphalt and grit. On the other hand, if the condition of the path is very bad, the holes should be filled up with asphalt, after which a thin layer (say 1/3rd inch) of ungritted asphalt should be laid down and a sprinkling of sharp ½ in. grit immediately rolled into the surface.

A concrete layer floated on top of an asphalt surface would, more likely than not, cause much trouble owing to the unequal expansion of the upper concrete and the low asphalt layers. We advise you not to consider this proposition, but if you do elect to carry on with it, take the precaution of spreading stout brown paper (preferably "Kraft Union" paper) over the upper asphalt surface so that the concrete is laid on the paper surface. The presence of this paper membrane

between the two layers of the different materials will, to some extent, enable a small sliding thermal movement to take place and thus may avert partial disruption of the path during very hot weather. In our opinion, however, if you favour a concrete path, the entire asphalt material should be removed, and the concrete laid on a good rubble foundation.

Do not use merely a mixture of pure bitumen and chippings for covering your existing path. The bitumen would soften in hot weather and become a great source of annoyance. The same applies even more so to tar, which has a very poor "temperature susceptibility," and which very readily softens in hot weather. Additionally, water draining from tar surfaces is very bad for a garden or for plants in an adjacent flower bed.

**Renovating Stained Leather**

**I HAVE** a new leather dispatch case which has been badly stained on the outside with indelible printing ink (as used for hand numbering machines).

Can you please advise me how to remove the stain without damaging the leather, and if the cleansing treatment removes the natural tan colour, how can it be restored to its original appearance?—W. Rudledge (Morden).

WE assume that your dispatch case has been stained by black printing ink. In this instance, it will be almost impossible to remove the stain, because carbon (the constituent of the ink) is absolutely unbleachable.

The appearance of the leather can be much improved, however. Go over the stained area with vaseline on a cloth pad. Then treat the stained area with a similar pad charged with hot paraffin oil. After this, repeat the process with a cold solvent, such as carbon tetrachloride, solvent naphtha, trichloroethylene or any other available grease solvent. It is no use applying any bleaching agent, since the carbon of the ink will resist its action and because the leather may suffer in consequence.

After these processes, the leather should be allowed to dry out slowly. It will look very unattractive and dull. You might now get over the difficulty by having the case dyed a deep shade of brown which would lessen the appearance of any remaining black stain. Otherwise, you should apply hot castor oil to the leather surface, allowing it time to sink in. This will revive the leather considerably, putting back the oil which the solvent treatments have taken out and rendering the leather supple again. The castor oil treatment will also darken the leather, thus making the remaining stain much less noticeable.

**Cement Paint for Roughcast Walls**

**I AM** told that any good quality oilbound distemper with lime added will provide a waterproof paint suitable for outside use on exposed roughcast walls. If this is so will you kindly inform me as to the proportion of lime required?

Can you also give me details of any other suitable paint mixture for the purpose apart from proprietary brands?—T. J. Page (Wolverhampton).

DISTEMPERS are usually based on casein, the glue-like substance extracted from skim milk. This is mixed dry with lime and borax (plus, of course, the necessary pigment). It is then made into a paste with water or with an oil emulsion. When the powder is mixed with water the lime and the borax react with the casein and render it soluble in water. On drying, the casein returns to its original insoluble condition and binds the pigment particles together in the paint film. The oil film which is deposited also acts as a binder.

If you add lime or borax to an existing distemper you will merely upset the "balance" of the mixture and will thus convert it into a glorified whitewash. Besides which some distempers do not contain casein, relying on the oil-binding properties of the medium. A good quality distemper will not be improved by the addition of lime or of any other compound. Distempers are not designed as outside paints. Although a distemper film is washable, it is not rainproof, and no amount of manipulation of the product will make it water-resistant. For outside use, therefore, you might just as well use an ordinary white or colour wash, consisting of the colour ground up with water or a weak solution of glue size.

For outdoor uses you can employ cement paints or silicate paints, but, in our opinion, the most reliable are the ordinary oil paints of either the flat or the gloss variety. Cement paint consists of white or coloured Portland cement. Mixed with materials to adjust their working qualities, they are supplied in powder form. The powder is then merely mixed with water for application. Such paints are suitable for new or old cement, lime and plaster surfaces, but are not suitable for wood or metal.

Silicate paint consists of the pigment ground into a solution of sodium silicate (waterglass), which becomes insoluble on drying. This paint is only suitable on cement, brick, concrete, plaster, asbestos cement and similar surfaces. It is strongly alkaline, and is not suitable for metal or wood. Used on metal, it may cause corrosion.

On a roughcast wall such as you mention either a cement or a silicate paint would be suitable. We would prefer a cement paint which is simple in composition, cheap and is not unduly alkaline. You can make such a paint by mixing Portland cement (about 70 parts) with a suitable pigment (about 30 parts). Both cement and pigment must be very finely ground. Make a paste of the mixture by adding water. Grind the paste well. Then thin it out gradually with additional water until you get a paint of good working consistency. As usual, the difficulty here is that of getting a fine grinding of the ingredients in the paste form, a difficulty which is inherent in all efforts at home paint manufacture.

# WILCO ELECTRONICS

204, Lower Addiscombe Rd., Croydon

**AIRCRAFT CLOCKS** with splendid 8-day jewelled movement, flange type, made to stringent Govt. specification. Brand new guaranteed. Ideal for car, study, bedroom, etc., will withstand vibration and shocks. Special offer, 65/- each, post free.

**PORTABLE TEST METER**.—Just the job for the home constructor, in neat case, 6in. x 5in. x 4in., reading 1.5, 3, 150 volts, 6 and 30 m.a., 5 k. and 25 k. ohms. D.C., 50/- post free.

**CLOCKWORK MECHANISM**.—Precision made movement with contacts making and breaking twice per second, can be used for switching on and off lamps, etc. Brand new in sound-proof cabinet with thermostat temperature control. Ideal for flashing signs. Price 15/6, postage 1/6.

**SHOWCASES**.—Hardwood with plate glass opening front, 3ft. 3in. x 2ft. 3in. x 3 1/2 in. Ideal for shops, factories, etc., 45/-, carriage 10/-.

**GEARED CAPACITOR MOTOR**, 200/240 v. A.C. 30 watt, size 7in. x 4in., 1,500 r.p.m., with 300 r.p.m. on final shaft, standard foot mounting, brand new, reversible, with capacitor, 84/-, post 1/6.

**KLAXON GEARED MOTORS** No. KKSBE—W17. Torque lbs. ins. 15. R.p.m. 175. Motor r.p.m. 1,400 at 230 v. A.C. Split phase induction type, £10 each.

**KLAXON CAPACITOR INDUCTION MOTORS** with 4in. fan, 1/40 h.p. 220/240 v. A.C., 2,700 r.p.m. No. EMSCB2 with condenser, 55/- each.

**24 VOLT D.C. MOTORS** with double ended shaft 2in. x 3in., 10/6, postage 1/-.

**THERMOSTAT SWITCH**.—Bimetal type in sealed glass tube, 2 1/2 in. x 1/2 in. 30 deg. Cent. Ideal for Aquariums, Wax and Oil Baths, Gluopots, etc. Will control 1 amp. at 240 v. 5/- each.

**VOLTMETERS**.—0-300 A.C. Moving Iron 2 1/2 in. Flush, 17/6; 3in. Flush or Surface, 22/6.

**MASTS, TELESCOPIC**, extending to 12ft. in 7 sections, 15/6, post 1/-.

**THERMOSTAT**, Satchwell 12in. stem 0-250 volts A.C./D.C., 10 to 90 deg. Cent. 35/-.

**SPEAKERS**.—P.M. 8in. Goodman, in wall case, with transformer, 21/-, Post & pks. 2/6.

**CYCLE LAMP BATTERIES TYPE 800**.—2, B. Make. Sealed Carton of 20 for 10/-, Post Free.

**RECEIVER R.1155**.—One of the best communication receivers covering 7.5 Mc/s to 75 Kc/s in 5 wavebands, complete with 10 valves. Brand new in maker's transit case. £12/10/0, carriage 8/6.

## For Metalworking and Woodworking

# MYFORD

## Lathes

remain

### THE CRAFTSMAN'S CHOICE

# Plastics LTD

(MANCHESTER)

11 Whitworth Street, Manchester, 1. Tel: Gen. 0272-1725.

BRITAIN'S LEADING STOCKISTS OF:

"PERSPEX" (Acrylic) sheet, rod and tube.

"CRINOTHENE."

B.X. ACRYLIC ROD.

P.V.C. SHEETING (Admiralty Specification).

"CASEIN" Rod, Sheet and Tube.

CELLULOSE ACETATE Film and Sheet.

Official Stockists for: IMPERIAL CHEMICAL INDUSTRIES LTD., ERINOID LTD., B.X. PLASTICS LTD., UTILEX LTD.

Catering especially for Industry, The Hobbyist and the Model Maker.

Contractors to the Admiralty, most Government Departments, Schools, Institutions, etc.

Trade and Technical enquiries solicited. Fabrication, Engraving, Moulding, Cutting to Size, Shape, Contour a speciality.

## MACHINE TOOLS AND ACCESSORIES

### METAL LATHES, Etc.

From 1 1/2 in. to 5in., Bench Millers, Drilling Machines, Hand Bench Shapers.

All Loose Tools and Equipment.

### WOOD LATHES, Etc.

From 3in. to 5 1/2 in., Ball Bearing Planers 4 1/2 in., 7in., 10 1/2 in. Ball Bearing Saw Benches 6in. and 12in. Sanders, Band Saws, Grinders, Jigsaws.

All Loose Tools and Equipment.

Write at once for details.

### NUTTALL'S (LATHES) LIMITED, MANSFIELD, NOTTS.

## You Can Become a HANDICRAFTS INSTRUCTOR

### EXPERIENCE NOT ESSENTIAL

Men who enjoy making things in wood or metal can turn their hobby into a permanent and interesting Career! Short hours, long holidays, and security in a job you would really enjoy, can be yours if you become a Handicrafts Instructor. Let us send you details of the easiest and quickest way to get the necessary qualification.

We definitely Guarantee "NO PASS — NO FEE"

If you would like to know about our unique method of preparing you for one of these appointments, write today, and we will send you an informative 176-page Handbook—FREE and without obligation. Mark your letter "Handicrafts Instructor."

British Institute of Engineering Technology  
591, Shakespeare House,  
17/19, Stratford Pl., London, W.1 **BIET**

### CIRCULAR-SAW BENCHES

6in. Saw Benches equipped for drilling, grinding and polishing. 1in. Cap. Chuck, Fast and Loose Pulleys, 92/6. Circular-Saw Blades, 4in., 7/6; 6in., 12/-; 8in., 18/6. Endless Vee Belts, 1in., 1in., 1 1/2 in. wide, all sizes. Round Leather Belting, 1in. to 1 1/2 in. dia. from 4d. ft. Shafting Collars, 1in. to 1 1/2 in. Send 6d. for Illustrated Catalogue D27.

**BEVERLEY PRODUCTS,**  
28, OAKWOOD AVENUE, LEEDS, 8

## ADANA PRINTING MACHINES

Print in the odd hours with an Adana—still the most absorbing of crafts. No. 1 H/S Machine £4.10.0 No. 2 H/S Machine £9.15.0. Will quickly pay for itself. Send for illustrated folder to Dept. P.M. 42

**ADANA (Printing Machines) Ltd.,** Twickenham, or call 8, Grays Inn Rd., London, W.C.1.



## DRILLS!!! DRILLS!!! DRILLS!!!

Immediate Delivery

### SET OF 10 HIGH SPEED DRILLS

CONSISTING OF 1" 1 1/8" 1 1/4" 1 3/8" 1 1/2" 1 5/8" 1 3/4" 1 7/8" 2" 1 3/16" 1 1/2"

OR COMPLETE WITH ATTRACTIVE METAL DRILL STAND

15/6 POST PAID. Satisfaction Guaranteed. TRADE ENQUIRIES INVITED

**J. SIMBLE & SONS**  
76, QUEENS ROAD, WATFORD, HERTS

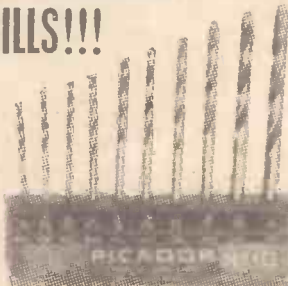

**PRACTICAL MECHANICS** (full Apprenticeship or Pupilage) may secure status of Professional Membership by using this COUPON.—To the Secretary, INSTITUTE OF EXECUTIVE ENGINEERS AND OFFICERS, EXECUTIVE CHAMBERS, 241, BRISTOL ROAD, BIRMINGHAM, 5. I AM INTERESTED IN MEMBERSHIP: PLEASE SEND ME AT ONCE PARTICULARS AND APPLICATION FORM:

NAME IN FULL (Block Letters).....

ADDRESS (Home) (Block letters).....

Present position..... Industry.....

Date..... 1951 Age..... Signature.....

Britool 0-9 B.A. Tool sets. Chrome Alloy Steel, in steel boxes, 26/-.

Moving Coil Microphones with Pressel Switch, 6/6. Matched Transformer, 5/6.

Small 24 v. D.C. Multi-gear Motor with reversible clutch, 11/6.

Westinghouse F.W. Bridge. 1 mA. Meter Rectifiers, 8/6.

Meters, Mic., 0-250 Milliamps. 2 1/2 in., 10/-, 2in. 0-300 v. 10/-, 0-1 mA., 11/6.

Multimeter Kit, 2 1/2 in. Meter. Volts 0-3-30-150-300-600 m/a 60. Ohms 5,000. With 1 1/2 v. Battery, 17/6.

250-watt Double Wound Transformers, 230/115 v. Made by G.E.C. With Steel Shroud. New. £2/7/6 each.

New Osram, Crompton, Mazda, etc., 12 v. Car Bulbs. Double contact. 10 watt, 1/3.

Transformers 230/24 v. 1 a., 13/6.

New Ultra 12in. Elliptical Energised Speakers, 400 ohm Field with Output Transformer, 21/6.

Powerful Small Blower Motors, 24 v. A.C./D.C., 14/-, Transformer 230/24 v., 13/6.

Army Carbon Microphone with switch, 4/6. Trans. to match, 3/6.

Admiralty 3 1/2 in. S.M. Dials, 100-1 with vernier. White Ivorine dial 0-100. Worm drive. New and Boxed, 8/6.

U.S. Army Lightweight Headphones. Fit inside the ears. 8/6 per pair.

Signal Generator 200 mcs. Easily converted to 144 mcs. or T.V. Bands. 11/6, or with 6-volt Vibrator Pack, 32/-.

All Carriage Paid. Money Back Guarantee from:

### THE RADIO & ELECTRICAL MART,

253B, Portobello Road, London, W.11  
Park 6026.

## NOW AVAILABLE GERMANIUM CRYSTAL DIODES

LATEST, SMALLEST, SUPREME CRYSTAL DETECTOR.

Midjet Size, 5/16in. x 3/16in. Wire Ends for Easy Fixing. 4/6 each, postage 2/6.

Wiring instructions for a cheap, simple but high quality Crystal Set included. Technical Details and Selected Types available.

**SILICON CRYSTAL VALVE** 3/6 each, postage 2/6. Fixing Brackets 3d. Extra

### COPPER INSTRUMENT WIRE

ENAMELLED, TINNED, LITZ, COTTON AND SILK COVERED. Most gauges available.

B.A. SCREWS, NUTS, WASHERS, soldering tags, eyelets and rivets. EBONITE AND BAKELITE PANELS, TUFNOL ROD, PAXOLIN TYPE COIL FORMERS AND TUBES. ALL DIAMETERS.

Latest Radio Publications. SEND STAMP FOR LISTS.

### CRYSTAL SET

INCORPORATING THE SILICON CRYSTAL VALVE

Adjustable Iron Cored Coil.

### RECEPTION GUARANTEED

Polished wood cabinet, 15/-, post 9d. A REAL CRYSTAL SET, NOT A TOY.

### POST RADIO SUPPLIES

83 Bourne Gardens, London, E.4

## WEBLEY AIR PISTOLS

Marvelously accurate for target practice.

No licence required to purchase for use on enclosed premises.

Senior. Mark I Junior. Webley Air Rifle

Write for List. **WEBLEY & SCOTT, LTD.** 106, Weaman Street, Birmingham, Eng

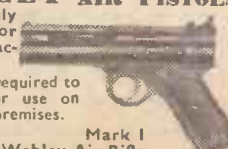

# POSTAL BARGAINS



TYPE 3

Type 4 for low temperatures, minus 300° F. up to 110° F. As for mounting through pipe line or tank, etc. Price **32/6**  
 Type 5 is as type 4 except that there is a much longer reach. Price **39/6**

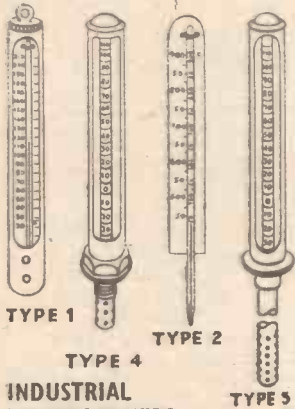

TYPE 1  
 TYPE 2  
 TYPE 4  
 TYPE 5

## INDUSTRIAL THERMOMETERS

Type 1 for ordinary temperatures, extra robust, heavy brass case with hook. Price **12/6** each

Type 2 reading up to 900° F., can be used without back plate, graduations engraved on glass. Price **7/6** each  
 \* Plus 2/6 for returnable transit case.

Type 3 for door or wall of baking or processing oven. Heavy brass case and protective cover. This reads up to 600° F. Price **32/6**

## 2 volt ACCUMULATOR

Suitable for radio or model driving, house lighting, etc. Heavy mass type plates—precharged—only need filling. New unused—size 7in. x 2in. x 2in. 15/- value for only **5/9** Post and ins. 1/3d.



## 4 VALVE RADIO

Means you can now have that extra radio. Ready to work, not a kit. AC/DC all mains. Four modern valves, gang tuning—high precision coils, condensers, resistor and other parts. Metal chassis, tunes Long and Medium Wave bands—large clear dial with station names—gets Home, Light, Luxembourg, etc. Ample volume. Complete and with **2 YEARS FREE SERVICE**



Chassis **57/6**  
 Moving coil speaker **15/6** ex. Nothing else needed.

## METAL TRIPOD

Tremendously strong, but not at all heavy. 3ft. high and with brass male and female thread top. Black Japanned pressed steel, unused, but may need repainting. 3/6 each, plus 2/6 post and packing.



**E. P. E. LTD.** (1) Electron House, WINDMILL HILL, RUISLIP MANOR, MIDDLESEX.

Meters. 10v., 21in. Rectifier (a.c.) in wooden carrying case, 14/6; 15v., 21in., m.c. 9/6; 150v., 2in., m.c. 10/-; 3,500v., 2in., m.c. 20/-; 6,000v., 3in., m.c., 57/6; 15,000v., 2in., m.c., double reading, 8/-; 100 m/a., 2in., m.c., 7/6; 3.5 amp. 2in., T.C., 5/-; 4 amp., 2in., T.C., in case with switch, 7/6. Meter Movements, 2in. size with magnet and case (500 microamp), 2/6. All meters post extra.

**Bell Transformers.** These guaranteed transformers work from any A.C. Mains, giving 3, 5 or 8 volts output at 1 amp., operate bulb, buzzer or bell. Will supply light in bedroom or larder, etc. PRICE 3/-, post 8d. BELLS for use with either the above or batteries, 6/-, post 6d. BUZZERS 3/-, or Heavy Duty 4/6, post 5d.

**EX-R.A.F. 2-valve (2-volt) Microphone Amplifiers** as used in 'plane inter-com., in self-contained metal case: can be used to make up a deaf aid outfit, intercommunication system, or with crystal set, complete with valves, 20/-, post 1/6. Useful wooden box with partitions to hold amplifier, 2/- extra. Ditto, less valves, 10/-, One valve amplifier, complete with valve, 9/6, post 1/-.

**Hand Microphones,** with switch in handle, and lead, 4/-, Similar instrument, moving coil, 7/6, post 6d.

**Mike Buttons (carbon)** 2/-, Moving Coil, 4/6, Transformers, 5/-, All post 4d, each.

**Sparkling Plug Neon Testers,** with vest-pocket clip, 3/3, or with gauge, 3/6, post 3d.

**S.B.C. Neon Indicator Lamps,** for use on mains to show "live" side of switches, etc., 3/6, post 4d.

**Soldering Irons.**—Our new streamlined Iron is supplied with two interchangeable bits, one each straight and curved; 200/250v. 50 watts, 10/-, Standard Iron with adjustable bit, 200/250v., 60 watts, 11/-, Heavy Duty Iron, 150 watts, 14/6, all post 6d.

**Crystal Sets.** Our latest Model is a real radio receiver, fitted with a permanent crystal detector. Have a set in your town room, 10/6, post 6d. De Luxe Receiver in polished oak cabinet, 18/6, post 1/-.

**Spare Permanent Detectors,** 2/- each. When ordered separately, 2/6, with clips and screws.

**210, post 3d.** **Headphones,** brand new, S.G. Brown, G.E.C., etc., 15/-, 23/-, and super-sensitive, 30/- a pair, post 8d.

**New Headphones,** 10/- a pair. Balanced armature type (very sensitive), 12/6 a pair. Both post 6d.

**New Single Earpieces,** 3/6. Bal. armature type, 4/6. ex R.A.F. earpiece, 2/-, post 4d.

**Headphones,** in good order, 4/6 and 5/6 (better quality), 7/6, all post 6d. (All Headphones listed are suitable for use with our Crystal Sets.)

Money refunded if not completely satisfied

**HIGHSTONE UTILITIES**  
 58, NEW WANSTEAD, LONDON, E.11.  
 New Illustrated List sent on request with 1d. stamp and S.A.E. Letters only.

*For*  
**ECONOMICAL**  
**CYCLE**  
**LIGHTING**

*Get a*  
**DYNAMO SET**

*Be sure it's*  
**LUCAS**  
**"KING OF THE ROAD"**

Sets, Prices: 27/6 to 75/-  
 No. 853 as illustrated 40/-

JOSEPH LUCAS (CYCLE ACCESSORIES) LTD • CHESTER STREET • BIRMINGHAM 6

# ENGINEERS

## ★ FREE BROCHURES ★ NEW COURSES

Technical training is vital to your success. Our Home Study Courses have now been very widely extended in range.

Write or 'phone for FREE BROCHURES detailing our courses of TECHNICAL TRAINING IN ALL BRANCHES OF ENGINEERING covering the syllabuses of the various professional examinations, City and Guilds, etc.

Moderate terms. Facilities for easy payment.

"THE COLLEGE BACKED BY AN INDUSTRY"  
 Write to Dept. 144:

# E.M.I. INSTITUTES

10, PEMBROKE SQUARE, NOTTING HILL GATE, LONDON, W.2. TELEPHONE: BAYSWATER 5131/2

Associated with  
 "H.M.V."  
**MARCONIPHONE**  
**COLUMBIA**  
 ETC.

1.12a.

## PRECISION TOOLS FOR PRACTICAL MECHANICS FOR IMMEDIATE DELIVERY



**JAGROSE 3" LATHE**  
 Surfacing, Screw-cutting, Set-over Tailstock, Hollow Mandrel, Complete with set of Screw-cutting Gears.

**£28-10-0**  
 E.P. Terms £7-10-0 deposit, 7 monthly payments of 69/-.

**3 1/2" MODEL £49-10-0 or E.P.**  

Jagrose Bench Drill	60/-	Jagrose Bench Grinder	10/9
Columbus Type Gauges	15/9	Jagrose Hand Vices	2/11

Send for particulars P.M.2.  
**JAMES GROSE LTD.,**  
 379-381, EUSTON ROAD, LONDON N.W.1. EUS 5231

## CHEMISTRY APPARATUS Send Stamp for COMPLETE PRICE LIST

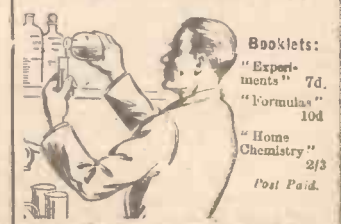

Booklets:  
 "Experiments" 7d.  
 "Formulas" 10d.  
 "Home Chemistry" 2/3  
 Post Paid.

**BECK** (Scientific Dept. A)  
 60 HIGH STREET,  
 Stoke Newington, London, N.16



Editor: F. J. C. AMM

VOL. XIX

APRIL, 1951

No. 347

All letters should be addressed to the Editor, "THE CYCLIST," George Newnes, Ltd., Tower House, Southampton Street, Strand, London, W.C.2.

Phone: Temple Bar 4363

Telegrams: Newnes, Rand, London

## Comments of the Month

Lord Lucas on the Accident Problem: His Address to the Roadfarers' Club, and the Club's Reply

By F. J. C.

**L**ORD LUCAS, Parliamentary Secretary to the Ministry of Transport, gave a talk to 120 members of the Roadfarers' Club at the Savoy Hotel recently, when he dealt with the subject of road accidents.

He anticipated that at the end of 1951 there will be 6,000 killed and over 250,000 injured on the roads of this country. He thought that the only hope was to influence the conduct of all road users, impressing them with the need for more care, more courtesy and more consideration. This, of course, is roughly the policy of Rospa, as the Royal Society for Prevention of Accidents is now known. He said that young people have more road sense than adults, but he did not know of any system for educating a woman who wanted to catch a bus! "If propaganda is useless we have to look for the greater enforcement of the existing law.

"I would like to see a greater number of police, as I am convinced that the respect of the British citizen for a uniform transcended everything else. It is hoped to increase the number of mobile police and of school children's wardens.

"Pedestrians must be prepared to have some liberty curbed, and the question of bringing them under some reasonable control by law is under review. And something must also be done about cyclists, who were almost in the privileged position of the pedestrian. At the moment there is only one thing upon which they can infringe—to ride furiously. I would not ride a bicycle at all. I am not going to lay the blame for accidents on any particular section of road user. I think that the vast majority of accidents are caused by carelessness on the part of all road users."

We were deputed to express the viewpoint of the Roadfarers' Club, which has since been transmitted to Lord Lucas as he had to leave the luncheon immediately after his own speech.

We told Lord Lucas that the Club had, at the invitation of his Ministry, prepared two memoranda which dealt with accidents and road safety and submitted them, and it was hoped that the recommendations would soon be adopted, as Mr. Noel-Baker, his predecessor, had promised to do so. The club feels that if you want to keep death off the roads you must keep pedestrians on the pavements. A great deal of money has been spent in constructing pedestrian crossings, and pedestrians should be made to use them. Pedestrians are in the privileged position of having absolute use of the roads and the pavements, a privilege not accorded to any other section of road user, and they must be made to use the devices erected for their benefit, otherwise such were a waste of money.

It has been argued, and particularly by the cycling organisations and those associated with those organisations, that greater enforcement of the existing laws as they

applied to motorists would reduce the toll of the road. This is dealing with the matter after the event. But if that argument is right then severe penalties must be inflicted on all road users.

We hear far too much about the number of accidents which occur and nothing at all about the far greater number which do not. It is grossly unfair to presume that motorists are always to blame. They have paid many thousands of millions of pounds to have the roads made suitable and safe for road users, but the money had been diverted to other purposes. Self-preservation is the first law of nature, and you cannot make a man careful by Act of Parliament any more than you can make a man sober by Act of Parliament.

Accidents, you tell us, and we agree, are due to carelessness, and as there are more careless pedestrians and more careless cyclists than motorists, some modification of the law must be made to bring them into line. Quite often they cause accidents in which they are not involved.

A large number of traffic lights should be removed now that it has been discovered that speed *per se* is not the prime cause of accidents. A collateral problem is the slow rate of traffic in London and other populous places, due to traffic lights.

What would be said of the Thames Conservancy if, when the river was in spate, they erected more weirs instead of pulling up the sluices! Roads are rather more dangerous when traffic is coagulated. What is wanted in London is a minimum speed limit, not a maximum.

As far as rear lights on cycles are concerned, the club sees no particular reason for rear lights on any vehicles. As the State has decided otherwise it could logically be argued that pedestrians should carry rear lights, since everything that moves along the road can be considered as a vehicle. Whether the feet are used for walking or for pedalling really makes no difference.

It is very evident that the Ministry of Transport agreed with most of these points of view, and the threatened legislation can be expected as soon as Parliamentary procedure permits.

### Death of Bob Carlisle

**W**E regret to record the death at the beginning of March of one of the last remaining links with the early days of the pneumatic tyre—Bob Carlisle, who passed away on his 86th birthday. He was associated with John Boyd Dunlop in the 'Eighties, and rode on one of the earliest of Dunlop's tyres.

He was also present at the Queen's College Sports, Belfast, when William Hume won the very first races on a bicycle fitted with pneumatic tyres. He was associated with the first Pneumatic Tyre Company in Dublin, and in 1896 joined the Dunlop Rubber Company at Coventry, transferring in 1902 to their sales ledger department at Birmingham. Since 1922 he was attached to the statistical department.

One of the first members of the Roadfarers' Club he last attended one of their functions when honour was paid to vice-president Sir Arthur Ducros, sole survivor of the family which founded the company.



Lord Lucas of Chilworth addressing the Roadfarers' Club. He is between Lord Kenilworth and Lord Donegall. Sir Miles Thomas, C. G. Grey and E. Coles-Webb are also in the picture.



JORDON RANDALL  
1950

Templecombe,  
Somerset.  
The old and picturesque little  
church.

*Paragons.*

#### More Cycle Racks

**B**EDFORD TOWN COUNCIL have approved a request by the Bedford and District Trades Council that more cycle racks should be provided in the town. The Trades Council felt that the provision of more racks would make for increased safety in the town, and racks are to be provided in Dame Alice Street and Allhallows Lane car parks and also, as an experiment, on the other side of Lime Street. Further racks may be provided as the need arises.

#### Obstructions Welcomed!

**O**BJECTS dropped on to the roadway from lorries are not usually welcomed by users of the road, particularly in country districts where street lighting is conspicuous by its absence, but residents in some of the coalfield areas are welcoming badly loaded lorries. On cycles and on foot they go out to cross-roads, sharp turns, steep hills and other strategic spots and wait for the coal lorries to pass. Sometimes as much as a hundredweight of coal has been seen to fall from one lorry—but it hardly had time to reach the ground before the watchers swooped! For once they are hoping that the police will not be too strict about the correct loading of the lorries.

#### He Kept Pedalling

**M**R. EDMUND SIDNEY WILSON, of Daventry, who entered the employment of a local firm of grocers in 1900 on a month's trial, has just completed 50 years with the firm, and during that time he calculates that he has cycled some 60,000 miles. In addition to cycling on the firm's business, he cycled from Daventry to Coventry every week-end for 45 years to visit his sister. Originally he used a pony and trap, but when he came back after serving in the 1914-18 war he used a cycle.

#### Best Year Ever

**I**T was stated at the annual meeting and prize-giving of the St. Neots and District Cycling Club that 1950 has been the best year since the club was formed. There are now 64 active members of the club and, including vice-presidents and honorary

members, a total membership of over 80. Mr. C. S. Williamson, treasurer for 12 years, announced his resignation at the meeting, after reporting a satisfactory financial year, and for his services to the club he has been appointed a vice-president. New awards are to be offered next season in addition to existing awards.

#### Smoothing the Shocks

**T**HE Huffman Manufacturing Co., of Dayton, Ohio, is now producing a lightweight shock absorber which can be attached above the front wheel of a cycle and is something on the lines of the motor-cycle shock absorber. For lightweight riders, or when riding on a good road, the tension is slackened, while the heavyweight rider or the rider on the average bad road has the

tension increased.

#### Started Cycling at 70

**M**R. JOHN THOMAS, the oldest resident of Immingham, who learned to ride a bicycle when he was 70 years old so that he could take up a new job 14 miles away from his home, has just died at the age of 98. He worked as a stationary engine-driver when Immingham Dock was being built, but when he reached the age of 70 he felt it was time he had a change of work. He had been living with his 65-year-old daughter, and he leaves two sons also, one aged 77 and the other 75.

#### Went Too Far!

**M**EMBERS of the Welland Valley Wheelers were told at this year's annual meeting that their 25-mile T.T. in the Market Harborough district has for years been run over a course measuring about 25½ miles. Originally the course was measured by means of a cyclometer, but this was apparently not quite accurate and a course of the correct length has now been measured by a proper instrument.

#### Sports Stadium for Leicester

**F**URTHER consideration is being given to the erection of a sports stadium at Leicester which, if it ever comes into being, will be known as Riverside Stadium. The proposed stadium would cover some 75 acres and would include a banked cycle track, running track, football pitch and accommodation for such sports as throwing the javelin, high and long jumping and putting the shot. Controlled tipping has taken place for some time at Aylestone, in the area of a proposed riverside development scheme, and if a stadium is to be built the drains and sewers will have to be laid before any further tipping is carried out.

#### The Gibbet Hill Ghost

**W**ARWICKSHIRE County Council is likely to go down in history as the "body" which laid the Gibbet Hill ghost, which for 300 years is said to have haunted the Gibbet cross-roads on the Watling Street outside Rugby. In 1678 the body of a murdered man was found in a field near the

cross-roads and ever since then his ghost is supposed to have haunted the fields and spinneys round about. His murderer was caught and his body hung in chains for weeks on a gibbet at the cross-roads and he, too, could not apparently settle in his grave. The County Council are now cutting down the trees on either side of the road and arranging for a traffic roundabout in an attempt to prevent the far too numerous accidents that have been occurring at this spot.

#### On to the Century

**P**ETERBOROUGH Cycling Club has celebrated its 76th anniversary with a dinner, dance and prize-giving, and among those present was Mr. W. S. Gibson, the oldest member of the club and treasurer of the British Road Records Association. He presented to Ray Needle and Len Young the association's special certificates for their tandem ride from London to York recently in less than eight hours. This was the first time in the history of the club that an attempt had been made to beat a national record, and the first time the club had gained national honours.

#### How Long?

**T**HE thought: "How long shall I have to wait before the traffic lights change?" often causes impatient motorists and cyclists to try to beat the lights. A Colsterworth (Lincs) man has invented an attachment for traffic lights which will show just how long it will be before the lights change. The device looks like a square box with a set of horizontal traffic lights on top and the whole surmounted by an illuminated globe. On the face of the box there is a large revolving disc, worked by a clockwork mechanism, which covers or exposes the colours, red, yellow and green, as the traffic lights themselves move through their regular cycle. The watcher can therefore see by the disc how long it will be before the lights change from one colour to the next. The inventor estimates that the device would cost less than £20 to make.

#### Bailey Bridge Chaos

**C**ASTLE DONINGTON (Leics.) Parish Council has in its area a Bailey bridge standing on the main road from London to the North, but the bridge is causing such chaos to traffic that it has been decided to press Leicestershire and Derbyshire County Councils to assist in getting the bridge removed and a new permanent bridge built. There are frequent hold-ups of traffic at the bridge and on one occasion the traffic lights failed completely, allowing two lines of traffic to meet at the centre of the bridge. Several members of the parish council cross the bridge daily, and they are prophesying a serious accident if something is not done at once.

#### Grass Gives Them a Headache

**T**HOSE grass verges along our country roads, which we usually ignore except when we manage to get our pedals caught by a tuft of grass on a dark night, seem to be causing local authorities throughout the country a good deal of worry. Nothing looks worse than stretches of untended and untidy grass verge, but the cost of the work these days is becoming prohibitive. At a recent congress of local authorities in London the whole matter was considered. One rather crafty suggestion was that in built-up areas part of the grass verge should be altered so that the footpath is next to the roadway, leaving a strip of grass in front of the houses. This strip, the local authorities think, would then be kept more or less in order by the various householders.



# Around the Wheelworld

By ICARUS



On route to the Kirkstone Pass, looking towards Kertmere fell with Sour Howes on the right, from near Troutbeck, Westmorland.

they brought in £1,702,792, as against the previous record, in March, 1949, of 221,710 for £1,535,910. The largest purchasers were Malaya (38,848), Brazil (21,207), India (19,998), British West Africa (17,484), Pakistan (16,007), and Southern Rhodesia (10,306). U.S.A. bought 8,513 for £68,946, more than twelve times the number and value of a couple of years ago.

## R.R.A. Watch Regulations

**I**N view of the abolition of the Kew "A" tests for watches and the substitution of a new test which checks up watches for isochronism, R.R.A. timekeepers in future will need to have and use a watch which has passed the new test. It must have hitherto passed a supplementary test, certifying that it is still performing within its original limits, every two years.

The position briefly is this. Holders of watches with current Kew "A" certificates will now submit them for the sporting test instead of the supplementary test. New watches must pass the craftsmanship test with the sporting test as a supplementary every two years. This ruling was made at the fifty-fourth annual general meeting of the R.R.A.

A surprise at the meeting was that Frank Armond, of the North Road C.C., was not re-elected. He has served for 24 years continuously on the R.R.A. committee. This was brought about by the fact that W. S. Gibson, the hon. treasurer, did not offer himself for re-election, that position now being held by George Martindale, of the Southgate C.C.

Mr. Gibson secured election as a committeeman, which displaced one of last year's committeemen. I am sorry that Armond has been displaced, for he was a useful man and had an enviable knowledge of cycling.

## The "Philite" Reflex Pedal

**J**A. PHILLIPS & CO. LTD. announce a new addition to their range of pedals for the home market—the No. 157 Philite Reflex Pedal. An adaptation of the No. 102 pedal, built with a solid one-piece aluminium alloy centre, it is fitted with replaceable rubber treads which are shaped to cradle the foot, as shown in the accompanying illustration. White silvered reflectors are fitted in front and rear side-plates, and their accurately formed surface ensures perfect visibility by motorists and other road users alike. Retail price is 13s. 7½d. per pair.

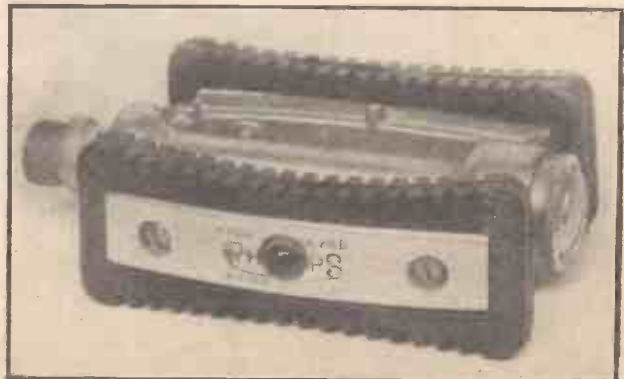

The New Philite Reflex Pedal.

## Motorised Tandems—Amended Law

**F**OLLOWING the anomaly in the Driving Licence Regulations which made it necessary for the rear rider on a motor-assisted tandem-bicycle also to have a driving licence as well as the learner rider on the front seat, representations were made to the Ministry of Transport, and the driving licence regulations have now been amended, so that the rear driver no longer has to carry a licence.

It would appear that the rear rider of an ordinary tandem-bicycle is still equally responsible with the front rider in cases of accidents. I do not know whether the amended driving licence regulations relating to motor-assisted bicycles will cause that particular law to be modified, too, but it ought to be.

## "On the Word of a Constable!"

**A** WRITER in a contemporary refers to the fact that cyclists can be charged on the uncorroborated word of a constable—or should I say *ipse dixit*? By inference he implies that this is not good enough, and that there should be corroboration. I fear this is impracticable. In cases of law-breaking, with the possible exception of speed limit cases, the word of the constable is mostly uncorroborated. Even when it is, the evidence agrees so closely that it is impossible to rule out the suggestion that they must have compared notes. All other witnesses are ordered out of court, whilst a particular witness is giving evidence, and it is thus possible by cross-examination to get witnesses to give contradictory evidence, even though their notes agree. However, as we in the cycling movement like to use Latin tags perhaps I ought to say that the rules of evidence vary according to the *corpus delecti*!

It can be a disadvantage to have two corroborating witnesses, for their evidence fortifies the case, and it is often impossible to rebut it. With a single officer there is always the possibility that under gentle cross-examination you can get him to weaken and to make certain admissions.

## Tour of Great Britain

**I** LEARN that the B.L.R.C. Brighton-Glasgow event is confined to first and second category amateurs only. The tour and the Butlin's event is open to independent and first and second category amateurs, whilst the first ten in the Final General Classification in the Brighton-Glasgow event will be entered in the tour as an invitation.

## London Traffic Problems

**A** FIVE-YEAR plan to relieve traffic congestion in inner London is proposed by the London and Home Counties Traffic Advisory Committee in a report to the Minister of Transport.

Essential and practical measures that, in the view of the committee, should be carried out or started within this period include the following:

The provision of more parking places off the street, including some above ground and others below ground.

Grants from central funds towards the cost of buying land and providing car parks.

An experiment with street parking meters, the revenue from which would help to pay for car parks off the highway.

Introduction of a system of unilateral waiting in streets within a radius of one mile from Piccadilly Circus.

Speeding up road repairs on the most important traffic routes by the general introduction of double-shift and week-end working.

Major road improvements.

## Our Cycle Record

**M**ORE British bicycles were exported during January than in any previous month of the industry's history. There were 236,519 of them, and

# Wayside Thoughts

By F. J. URRY

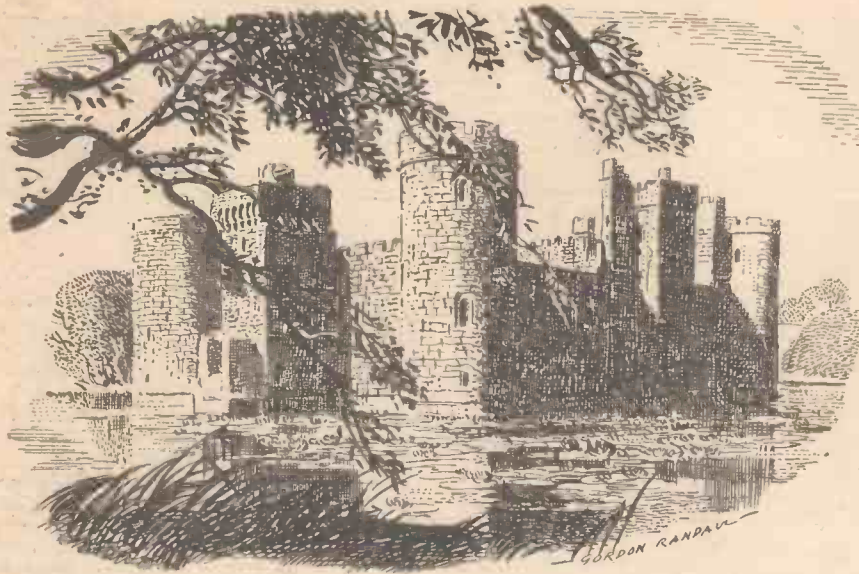

*Bodiam, Sussex. The last great medieval castle to be built in England (1386). The actual setting and approach to the castle is one of great beauty. It is now National Trust property.*

## Make a Date

OF the making of dates there is no end, nor, unfortunately, of the breaking of them. Before destruction I had a glance through my 1949 diary and found an astonishing number of assignments that were not fulfilled. This, however, will not discourage me from making similar dates during this year of grace, and I'll tell you why. If you allow the weeks ahead to go unframed by intention, then almost certainly you will find some of the days will run to waste in the cycling sense. The opportunity to go roaming will come and the companionship will be missing, the area undecided and no arrangement made, with the result that as often as not, the free hours will be frittered away, generally in an unsatisfactory manner. So make your dates, and if perchance you cannot keep them all because of the pressure of circumstances, the other fellow will understand if he or she is a real friend. It will surprise you how easily and happily the leisure hours slip away if you will use a loose sort of programme to act as a guide to intention.

## Easier and Easier

A GOOD thing is going to happen in the not too distant future. About a year ago I was presented with an inner tube and told I would never need to inflate it once it had been blown tight. Most of the summer I carried that tube around on my long journeys as a spare, then, needing its help, put it inside a front cover. Within a hundred yards it was flat, but the cause was a fat hobnail in full advertisement, and I repaired the damage in 10 minutes and wondered if this perforation would affect the supposed virtue of air-tightness. That was many weeks ago, and morning after morning I thumbed that tyre, but the pressure held, and now I've given up the examination and should be very surprised if it let me down. The secret, I'm told, is some preparation now difficult to obtain, but that position will be remedied in due course, and air tubes in future will be really air-tight, and the inflator will have a rest.

That will be good for us, for the pumping of a tyre was never a joy, and, furthermore, because so many people shy at it, tyres are frequently misused. This is Mr. Dunlop again, and as soon as he is ready to say the word I'm all for the air-tight tube. While on this subject I ask in all seriousness why the solution tubes in our repair outfits are such wretched things. I find as often as not in a new outfit the solution is a mere jelly instead of being fluid. The right thing is to carry a screw-top tin of solution separately, I agree; but why should a repair outfit not be complete and, if necessary, contain a screw-top tin of solution instead of the collapsible tube, which seems to be correctly named!

## This is True

DURING the last year I have bought four new bicycles, all the best type made, all 21in. frames with 1 1/2in. wheels and Dunlop Sprites, and all four-speeded with 50in. normal gears. The makes are Raleigh, James, Phillips and Enfield, and from the "feel" of them a wheel I don't believe I could tell one from the other. The first question you will ask is why do I want four new bicycles, and my simple answer would be because I like 'em, and as a man must have a main extravagance, that is mine. What I want to say here is that all these machines are excellent, and I wish for none better. I'm told that the specially made lightweight *must* be a better bicycle. Now I've used many such machines lately, and long ago, when the big factory was concentrating on the mass-produced article, and apparently was unaware or didn't care about the folk who wanted the best and were prepared to pay for the privilege. True, they were few in the days of the early 'thirties, but since then quality cycling has advanced enormously, and I think is only now in its infancy. To-day the big makers are aware of this change, and the machines I own—and many another—are the signs of their trading interest. All these bicycles of mine weigh well under

30lb., are made with intimate attention detail and run as silkily as any I have ever ridden; so you see the big factory can make quality as well as quantity. Not that surprising; Dunlop make quality tyres as well as quantity, so why shouldn't the cycle makers do the same with bicycles. These thoughts are expressed as the result of a query raised by an old friend of mine who seemed to be firmly of the opinion that only the specialist could make the real stuff. Thirty years ago he may have been right except, in a few instances, Sunbeam and Lea-Francis; but not to-day. The good bicycle carrying a world-famed transfer has come to stay, and, I firmly believe, will increase enormously during the next decade.

## It's Always Good

OUT into the rain and home. What a fool you are, they say, when a car can take you to your door. Am I? Maybe you are right, but I don't think so. You see, I get a seven-miles ride and 40 minutes exercise after a day in the office. I stretch my legs and my lungs and—this is important—I enjoy it. To be whisked home may suit some people, but verily I believe I would be more weary, and I know if the easy habit grew upon me I would grow older more rapidly. And I am free to start a stop when I like, almost as simple as the walker, but with four times his speed and almost costless. Indeed, the nearest thing in travel to something for nothing. The week later I was out on a day when the sparkling showers went over me in little grey battalions with the sunshine dropping between in all the glory of spring. My companion complained, because it was a day of mock exercises, or a chase for shelter but what does it matter? We were out among the hills, and the far visions seemed of another world, so plain did they appear against the purple background of the late storm that had sprayed us. And if a man never feels the rain on his face, the cool splash of it, how shall he understand the varied delight of this climate? Perhaps we take too much care of ourselves and grow soft, which is a thing not in the catalogue of health wisdom. I like the good weather best, but is all the good compacted of sunshine and following winds? Were it so—and most assuredly it is not—then part of the adventure of the road would disappear and if the average cyclist is not an adventurer physically and mentally then he would be wise to forget that the hum of a wheel is the music of magic.

## A Resolution

DURING the next few weeks—I hope—is my intention, made in this slack period of fireside reflection, to undertake as many cycle journeys as Fate will let me. I am not in the least ambitious to make big daily rides, but to potter around in comfort, especially to the old places that filled me with eminent satisfaction when I was younger but often in too much of a hurry to pass on and change the scene, as in the way of the virile and mileage opulent. So I am waiting for the spring, for that superb adventure of the years when everything is in promise and the world seems very young. That's my mood now, and it is encouraged by my nearest relatives—because, praise be—they think I have done enough work! How much of their mood is due to ridding their modern notion of the old man so that they can push forward changes without his criticism, if would be hard to say. That may be an unworthy thought because deep down I believe they wish me mellow days and happy ones as the toll of them runs out.



**THE "FLUXITE QUINS" AT WORK**

"Oh, please see what you can do,"  
To our cuckoo clock," exclaimed OO.  
"It will never be right Without some FLUXITE,"  
Cried OI, "That's occurred to me, too."

For all **SOLDERING** work—you need **FLUXITE**—the paste flux—with which even dirty metals are soldered and "tinned." For the jointing of lead—without solder; and the "running" of white metal bearings—without "tinning" the bearing. It is suitable for **ALL METALS**—excepting **ALUMINIUM**—and can be used with safety on **ELECTRICAL** and other sensitive apparatus.

**With Fluxite joints can be "wiped" successfully that are impossible by any other method**

Used for over 40 years in Government works and by leading engineers and manufacturers. Of all Ironmongers—in tins, from 1/- upwards.

**TO CYCLISTS!** For stronger wheels that will remain round and true, here's a time-tested tip. Tie the spokes where they cross with fine wire **AND SOLDER**. It's simple—with **FLUXITE**—but **IMPORTANT**.



THE "FLUXITE" GUN puts "FLUXITE" where you want it by a simple pressure. Price 2/6 or filled 3/6.

ALL MECHANICS WILL HAVE

**FLUXITE**

IT SIMPLIFIES ALL SOLDERING

Write for Book on the **ART OF "SOFT" SOLDERING** and for Leaflets on **CASE-HARDENING STEEL** and **TEMPERING TOOLS** with **FLUXITE**. Also on **"WIPED JOINTS."** Price 1d. Each.

**FLUXITE LTD., Dept. P.M., Bermondsey Street, S.E.1**



**SAFE BRAKES**  
rain or fine

Ferodo All Weather Brake Blocks are made of a special friction material that is practically unaffected by weather and can be relied on to give you safe, positive control for long hills or emergency stops.

The price of standard sizes is now

**6<sup>d.</sup> A PAIR**

**HUB BRAKES.** Ferodo Linings are supplied in boxed sets, complete with rivets, for all makes of hub brake. The size is exact, and the friction characteristics correct, for each type. Also available in roll form.

**FERODO**

**ALL WEATHER BRAKE BLOCKS AND LININGS FOR HUB BRAKES**

REG'D TRADE MARK  
**FERODO LIMITED, CHAPEL-EN-LE-FRITH**  
A member of the Turner & Newall Organization



**CYCLING SAFETY CAMPAIGN**

**PALCO Shock Absorbers**

- Reduce skidding on any surface
- Assure safety when cornering
- Lessen wobble over bumps
- Eliminate broken lamp bulbs
- Lengthen life of tyres
- Reduce fatigue over long distances
- Minimise shock in case of impact

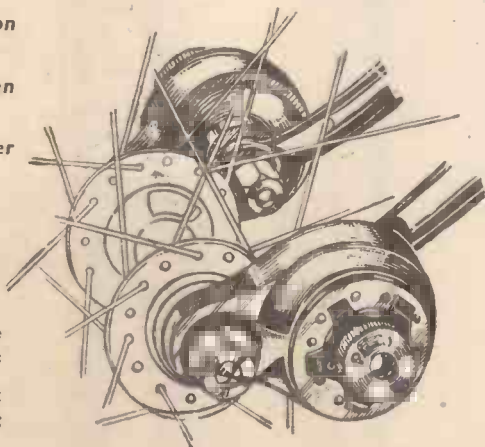

If these and many other advantages are gained by fitting **PALCO Shock Absorbers**. Why not join the **Palco Safety Campaign** now?

**LIGHTWEIGHT De LUXE TYPE**  
(for all normal requirements)

**HEAVY DUTY De LUXE TYPE**  
(for motorised cycles, tandems, etc.)

**25/6**

**30/-**

asily fitted. Adjustable to rider's weight. Approved by leading Cycle Clubs. From good Cycle Shops everywhere or direct from

**PALCO CYCLE PRODUCTS LTD**  
21 KNIGHTSBRIDGE LONDON S.W.7

# TOURING • CLUBWORK • RACING • HACKWORK



*whatever you do...*

# ..rely on- DUNLOP

also in the range but not illustrated  
CUSHION, JUNIOR, OVERSIZE & BALLOON

## THE WORLD'S LARGEST RANGE OF CYCLE TYRES

50H/350

*Cycling is grand fun....*  
**IT'S TIME YOU HAD A**

# BSA



CYCLING really is grand when you ride a B.S.A. with B.S.A. 3-speed hub with Snap Control for quick, positive change of gear.

**COUPON:** To B.S.A. Cycles Ltd.,  
12, Armoury Rd., Birmingham, 11

*Please send me at once the B.S.A. Cycle catalogues*

NAME .....

ADDRESS .....

**IMPORTANT NOTICE to**  
**Owners of MOTORISED BICYCLES**  
You've got the **EXTRA MOTIVE POWER**  
**NOW** you need the **EXTRA BRAKING POWER**

## “Cantilevers”

(REGD.)

**MOST POWERFUL and SMOOTH ACTING**  
**CYCLE BRAKES in the WORLD**

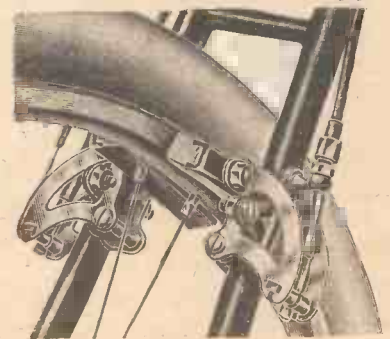

CANTILEVERS have been given special tests on bicycles fitted with many of the leading Motor Units, and as a result they are being strongly recommended for their complete **EFFICIENCY** and **RELIABILITY**. Your life depends upon your brakes, and the addition of a motor unit to your bicycle makes it vital that you are equipped with the best brakes obtainable. CANTILEVERS will give you complete **CONFIDENCE** in ANY EMERGENCY. Fixed rigidly on the forks or stays, they are always positive in action, smooth and powerful, grip well in the wet, and give long service. Special models available for use on Westwood rims. Fitted with our Locking Lever, they make the ideal **SAFEGUARD** against petty thieving. Twelve month guarantee with all new brakes.

**SAFETY FIRST! Second Thoughts are Too Late**

THE RESILION CO. LTD., 200, LIVERPOOL ROAD, LONDON. N.1.

# CYCLORAMA

By  
H. W. ELEY



Inigo Jones Windmill,  
Chesterton  
Warwickshire

Originally built by the great architect as a look-out tower for Sir Edward Repto.

## Royal Patronage for the Cycle Show

IT is good news, and a compliment to the British cycle and motor-cycle industry, that their Majesties the King and Queen have agreed to be patrons of the 1951 show (to be held at Earls Court from November 10th to 17th)—and that Princess Elizabeth and the Duke of Edinburgh will be vice-patrons. No industry more richly deserves a Royal gesture of interest and approval; and, incidentally, I do not think that any industry stages a more attractive show. Dull November days seem brighter after a visit to Earls Court, and an inspection of the gleaming models from our busy cycle and motor-cycle factories.

## "Warnings in Triplicate"

THE National Committee on Cycling reminds us that no other cyclists in the world have to show three different types of "warning" on their bicycles. The committee recently sent a memorandum to the Minister of Transport pointing out this burdensome obligation, and reminding him that under the 1945 Act, he, as Minister, may compel all cyclists, when the supply of materials permits, to carry a rear light, a reflector and a white patch. It is the committee's suggestion that the situation could now be met to everybody's satisfaction by reverting to the pre-war practice of giving a choice between a rear light and a combination of reflector and white surface.

## Boston "Stump"

CORRESPONDENCE still reaches me from cyclists who share my love for the scenes and places of England, and I always welcome these good letters which tell of interesting tours, of happy week-end rides, and of places seen and enjoyed. The other day a rider wrote to me and enthused over Boston, in Lincolnshire . . . and particularly over Boston's famous "Stump." Now I am one who loves Lincolnshire, and I recall that Boston "Stump" was at one time used as a lighthouse for men at sea, also for travellers over the Fens. But Boston does not rely for its charm and fame on the ancient "Stump" . . . it is a fascinating old place, with its narrow, cobbled streets, its old warehouses, its

market-square, and its old Guildhall. In the latter one may still see the cells in which the Pilgrim Fathers were imprisoned for daring to try and leave the country in the year 1607! However, they did leave . . . and, as every schoolboy knows, sailed away in the *Mayflower* in 1620. Yes, I could browse for a long time in Boston, with its market, its quays and shipping, and its reminders of history.

## The English Village

THE face of old England has changed a lot in recent years; the individuality of many of our old towns has gone . . . the standardised sign of the multiple-shop tends to rob the old market town of its character, the inn signs—in many places—have lost their charm, and all look alike. But . . . many an old village remains as it was a century ago. There is the grey old church, the little inn with its low-ceilinged rooms, the cottages which, in high summer, are embowered with flowers, and the old farms where patient-eyed cows gaze at one over gates, and hens cluck proudly as they escort their chickens to the stack-yard. Our villages are our bulwarks and our pride, and the other Sunday morning, as I walked through my own particular village to church, I met with a happy little company of cyclists from a neighbouring big town. They had come to "see a bit of the real England" . . . so said their spokesman when I stopped for a chat. They had the right idea . . . these fellows and girls who worked all the week in a factory. They had cycled out to the goodly sights and sounds and smells of the English countryside. Jasmine Cottage enchanted them; the ancient walls of the church impressed them, and the sight of a handsome roan mare and long-legged foal intrigued them . . . more than did the tractor in the inn yard. They told me that every Sunday they "did a run" out to some village and felt all the better for it when Monday morning came and the factory claimed them. How firmly I agreed with them!

## "One Man's Meat . . ."

SOME little time ago I made reference to the best form of food for the cyclist when on a long ride. I believe I plumped for cheese and chocolate. Now I have a letter from a rider who sings the praises, and voices the virtues, of bananas! This

rider thinks that no food has such sustaining qualities, and talks of the "clean and handy" form of the fruit. Well, I suppose that bananas are good and convenient to eat whilst on the road, but I am afraid I remain staunch to bread and cheese . . . washed down with a pint of ale at some friendly little tavern. But I do not expect all riders to share my enthusiasm for cheese, or for old inns; I think it depends largely on one's age . . . and when one has reached sixty, the less said about age the better!

## Value for Money

EARLY in 1940 I bought a bicycle in the ancient Royal Borough of Sutton Coldfield, and the price was £5 15s. 6d. I am sure of the cost because, delving among some old bills and papers recently, I came across the receipted account. I have ridden that machine regularly ever since—and I cannot but think that my purchase represents astonishing value for money. What miles of pleasure I have had from this old friend! What good moments I have spent, the bike propped up against a gate, looking across Midlands fields, smoking my pipe, musing upon the hedges and streams and little hills of the countryside! There can surely be no better "buy" than a bike . . . and it rather surprised me to find that even after the war had started one could purchase a first-class machine for such a modest sum. Other bikes are in my "stable" . . . but I have an affection for this wartime model . . . an "Armstrong" . . . and I hope it will carry me many more miles now that I am living in pleasant Derbyshire, with fair Dovedale not far away, and awesome Kinder Scout within easy reach. . . .

## Market Day

I HAVE always loved market-day in an old English town, and the other week I spent a day in ancient Uttoxeter, in Staffordshire, and the market was in full swing. A farmer had told me previously that Uttoxeter was one of the best markets in the Midlands if you "were interested in cattle." Well, I'm interested in cattle, and watched with fascination the buying and selling of Shorthorns and Ayrshires, and I revelled in all the hustle and bustle of the place . . . talked with farmers in little inns, bought daffodils, wandered around the colourful open-air market stalls where everything from nylons to yard-brooms, from ties to tin-openers, from chocolates to corsets was displayed; and I walked round the fine old parish church which towers like some guardian angel over the place, and noted the impressive stained-glass windows and the beautiful "Children's Corner." A good day . . . and never once in all my ramblings did I hear the place called "Utcheter" or "Uxeter"!

## EVERY CYCLIST'S POCKET BOOK

Owing to an unprecedented demand, and in spite of a large print order, the first edition of this cyclist's "Bible" went out of print shortly after publication.

We are pleased to be able to announce, however, that special arrangements have been made to produce a Second Edition which is now on sale. Copies may be ordered from newsagents, or direct from us. Copies cost 7s. 6d., or 7s. 10d. by post, from the Publisher, Book Dept., George Newnes, Ltd., Tower House, Southampton Street, Strand, W.C.2.

The book measures 5in. x 3in., is strongly bound in green cloth with gilt lettering, and contains 400 pages of valuable information and tables on every aspect of cycles and cycling, including 84 pages of indexed road routes of Great Britain.

Order Your Copy Now!

## Montacute House.

Somerset.

One of the finest specimens of Elizabethan architecture in Somerset. It dates from 1580. The great Gallery extends the whole length of the house and is sixty yards long. The great house is set in magnificent formal gardens.

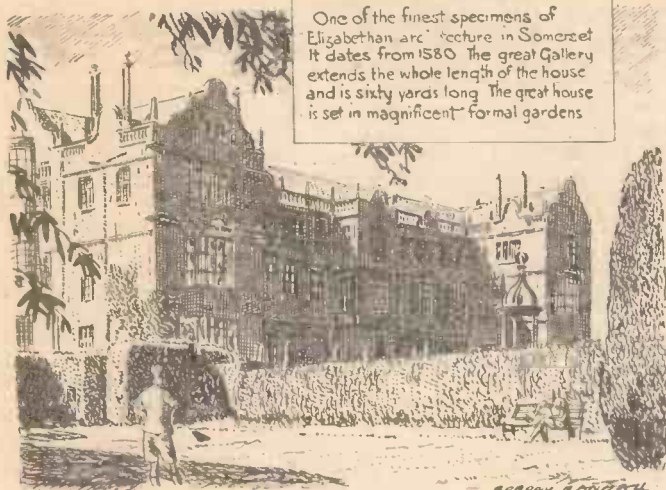

### Hills and the Sea

WITHIN a very short time after the preparation of these notes I shall hope to be on the way to one of my usual playgrounds, in search of hills and the sea, and of lakes and valleys and rivers, and woods and forests and moors. Easter—for as I write, it is the eve of that great festival—produces many provocative thoughts and most cyclists look forward with tremendous enthusiasm to the first statutory holiday of the year. Of that enthusiasm it may well be said that “age cannot wither nor custom stale its infinite variety.” All this will be history by the time these words appear, and Easter will have taken its place with the things that were. For the moment, however, I am revelling in the delights of anticipation, and the circle will not be complete until anticipation is dethroned by realisation, and retrospection—to endure for “as long as memory holds its seat”—succeeds realisation. There are three main joys—always three—attached to this grand game of ours.

My intention is to go to Wales, in search of those two topographical features which have never failed to inspire me and fill my heart with joy. Hills and the sea! My very first Easter week-end as a cyclist, now nearly 60 years ago, was spent in that gracious land, almost in sight of which I was born, and pictures of which came distinctly into all the walks of my childhood. That first Easter week-end was memorable if only because I did everything, or nearly everything, wrong, despite the fact that my parents had been active cyclists for years, and despite the fact that my companion, much older than I, was a man of considerable cycling experience. The most wrong things I did was to wear a yachting cap, and to convert, temporarily, a pair of trousers into knickers by the simple process of turning them inside out and then drawing the legs as far as they would go up my thighs. They were then internally secured with string below the knees and turned over into their normal position, and fastened with braces in the ordinary way. Believe me, it was not clever!

I have always deprecated the use of long trousers for cycling, but such garments, worn normally, are the very acme of comfort and

efficiency as compared with the burlesque—and, indeed, comic opera—result I achieved . . . and be it noted it was done under the supervision and on the advice of my experienced companion.

A greater mistake, for which the responsibility also lies elsewhere, was the inclusion in our outward and homeward itinerary of that stodgy and uninspiring coastal road which helps to link Queens Ferry with Rhyl. I was in my teens and knew no better. My experienced companion should have used his grey matter and found a much more alluring

with its calls on “all sorts and conditions of men,” provides me with many interesting contacts, and emphasises the extreme value of the vast cycling background I possess, I regret the repetition. A member of the committee which gave me the appointment asked: “Do you know the region?”—and I refrained from bursting into laughter, which I am sure would have been misunderstood! My reply was that I had lived in, and cycled throughout, the district for at least a quarter of a century, and that seemed to settle the matter. Frankly, it is tremendous advantage to know the locality. If I am not on speaking terms with every little place, I pretty well know where to find it and how best to get there, and this cycling background of mine is really a tremendous advantage. My lifetime of wheeling has been indulged in purely for pleasure purposes and now, in these latter days, there comes this important by-product which is proving so valuable. In my view, the pastime of cycling takes second place to none, and here, superimposed on all that the great game can do for one in the way of physical and mental health, is the education factor.

### In the Black Country

IN my business journeyings it is frequently borne in upon me that I am a man with a past. For instance, I went into a grim factory in the Black Country a few weeks ago and was just about to present my card when an official who was standing there said: “Oh! there’s no need to tell me who you are!” and he began to talk of the work I had done for cyclists in the early years of the present century.

Another angle may be mentioned. While waiting in the drawing-room of a large country house in North Staffordshire my attention was attracted by a painting which hung over the fireplace. “Paul Henry,” I ejaculated—and I was quite excusably wrong. The picture might well have been painted by that famous Irish artist. It depicted a scene in Connemara, and I stood there in silent worship of those colourful mountains and glorious lakes. I was 300 miles away in a moment, wheeling along the rugged roads of the West, and steadily drawing the Twelve Pins nearer and nearer, when I was brought back to earth by a lady’s voice which said: “Good morning! You wanted to see me?” To that greeting and question my irrelevant retort was: “I thought it was a Paul Henry!” So we left business alone for a few minutes and talked about Ireland—the land of her birth—thus providing a solid platform for afterwards explaining the purpose of my visit.

What has all this to do with cycling? Well, but for cycling I would not be familiar with Connemara—and a thousand-and-one other places. But for cycling I might be unfamiliar with the works of Paul Henry. Just that! These points might well be borne in mind in connection with our pastime, which we follow, primarily, because of the health-giving exercise it provides. Cycling makes and keeps us fit. It weather-proofs us. It develops us into knowledgeable men and women—travelled men and women. It provides us with that invaluable background of which I have spoken. It turns us into folks who can speak of places with an air of authority. It fills the storehouse of the mind with permanent pictures of Connemara, the Hills of Donegal, the Outer Hebrides, the Trossachs, the Lake District, the Yorkshire Moors, the Cotswolds, the Conway Valley and Devon. And yet people decry cycling as something almost unclean!

## My Point of View

By “WAYFARER”

route than that. My subsequent attitude towards the road in question carries with it a permanent vote of condemnation. In the succeeding 60 years or so I have not travelled that way again!

### Round the “Wrekin”

SO, returning to my main theme after this digression—this excursion “round the Wrekin” (a hill, by the way, of considerable charm)—I hope to be stretching out for hills and the sea within a few hours of typing these words. It will not be my fault if I do not obtain great optical gulps of Cardigan Bay. As I go by, I shall hope to see all the shapely hills of Shropshire. I shall confidently expect to gaze at Snowdon and at all those mighty uplifts constituting the tumbled group of which that famous mountain is the central figure. I hope to pass in the shadow of Plynlimon and Cader Idris. I may feel slightly hurt if those picturesque hills wrongly called “The Rivals” elude me. Possibly I shall look directly upon the Irish Sea, but water in other forms—Lake Bala, for instance—should come within my view, while I shall gleefully anticipate gazing at those alluring variants of the sea proper, the estuaries of the Maddach and the Dovey.

So hills and the sea for me. The sea has a crippling effect on a cyclist’s activities, for it closes the door in certain directions. Hills may have a retarding effect, for your average speed—if you have one!—tends to crash when the roads go up and down without a break. But, to my mind, this is the type of country where the real joys of cycling abound. I like the speedy main road “bash” as well as anybody, but, for the sheer joy of living as a cyclist, give me the ups and downs of a hilly road—for example, the English Lake District, the Scottish Highlands, the playgrounds of Western Ireland, and Wales. The “going” may not be easy, my masters, but how rewarding to the cyclist of discernment are hills and the sea.

### Out of the Past

IF I have previously remarked that I rather special job of work I am now doing,

“Practical Mechanics” Advice Bureau  
This coupon is available until April 30th, 1951, and must be attached to all letters containing queries, together with 3 penny stamps. A stamped, addressed envelope must also be enclosed.  
Practical Mechanics  
April, 1951

COUPON

Published about the 30th of each month by GEORGE NEWNES, LIMITED, Tower House, Southampton Street, Strand, London, W.C.2, and Printed in England by W. Spaight & Sons, Ltd., Exmoor Street, London, W.10. Sole Agents for Australia and New Zealand—Gordon & Gotch (A/asia), Ltd. Sole Agents for South Africa—Central News Agency, Ltd. Subscription Rate (including postage): For one year, Inland and Abroad 14s. (Canada 13s.). Registered at the G.P.O. for transmission by Canadian Magazine Post.

**"They Laughed at First**

but when I began to play—hush fell upon the room.  
I played the first few bars of Beethoven's immortal "Moonlight Sonata." My friends sat spellbound, and when the last notes died away, the excitement on their faces! "Who was your teacher?" "How do you get that lovely singing tone?" I receive similar letters daily from students of MY POSTAL Lessons for the PIANO who started, without knowing or note. My class is seldom less than 2,000 pupils. I have taught over 88,500 and I CAN TEACH YOU. Ordinary musical notation only used (no "breakish" methods), enabling you to read and play at sight any standard musical composition. Send p.c. for FREE book and tree advice. Say Moderate, Elementary or Beginner.

MR. H. BECKER  
(Dept. 558),  
69, Fleet St.,  
E.C.4.

**Jubilee**  
PATENTED  
WORM DRIVE  
CLIP



Absolutely leakproof joints on Air, Water, and Oil lines are swiftly and easily made by using "Jubilee" Worm Drive Clips. They stand up to any pressure.

★ Write for details and prices  
R.P.12. THE FINEST CLIP IN THE WORLD.

**NO MAN CAN KNOW TOO MUCH OF HIS PRODUCT**

For the close scrutiny of every conceivable object, metals, tools, fabrics, fibres, minerals, precious stones, paint, print, manuscripts, biological and botanical specimens, cutting edges, fractured surfaces, raw materials, powders, granules, and innumerable other purposes, the ULTRA LENS is invaluable, and presents in many instances hitherto unsuspected data which can be used to advantage.

The Ultra Lens is a revealing eye of six actual diametrical magnifications, which brings out points of strength or weakness, and enables the most minute measurements to be gauged accurately. Whether you are engaged in manufacturing, buying or selling, it is an ally of real value. No instrument you can buy will more quickly justify and pay for itself. Full particulars on request.

PRICE £4 15s. 0d., complete in case with spare bulb, battery and transparent measuring scale. ADAPTOR, A.C. Mains, 27/- Transformer, if required, 6/6.

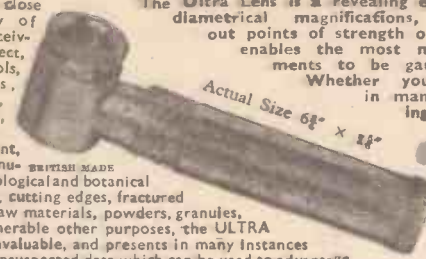

**THE ULTRA LENS COMPANY,**  
75, Finsbury Court, Finsbury Pavement, London, E.C.2.

**SPARKS' DATA SHEETS**

Now recognised as the Safest, the simplest and the Finest Radio Constructional Sheets obtainable. All my Designs being Fully Tested and Guaranteed, you are sure of

COMPLETE SATISFACTION.

**GOOD LISTENING WITH ECONOMY**

Four more of my TESTED and PROVED All-dry Battery Designs

**THE POCKET PAK.** The finest little self-contained Pocket Portable One-valve obtainable. Med. waves. Good 'phone sigs. Most widely used and always praised ... 3/-

**THE JUNIOR.** A very efficient one-valve for use with short aerial. Med./Long waves. Good range and an ideal "stand-by" ... 3/-

**THE CRUISER.** A three-valve T.R.F. High-gain Set. Specially designed for use where only a short aerial can be used. Ideal for Caravans, Camping, Yachts, etc. M.L. Waves ... 3/-

**THE CORVETTE.** A compact all-wave Superhet. Good results anywhere with "hook-up" aerial, or a good Portable with self-contained aerial. Chassis size 5 1/2 x 4 1/2 x 2 1/2 ... 3/-

The above are only 4 of the 40 designs available.

SEND STAMP FOR COMPLETE LIST. COMPONENTS SUPPLIED.

**L. ORMOND SPARKS (M)**  
48A, HIGH STREET,  
SWANAGE, DORSET.

**A. J. REEVES & CO.**

**CHAMPION No. 2 Drilling Machines,** 0-1/2 in., £13-15-0 carriage paid.

**SELECTA 4 1/2 in. double-ended portable Grinders,** £7-5-0 carriage paid.

**WOLF TG6. 6 in. bench Grinders,** single phase, £13-15-0; three phase, £14-15-0 carriage paid.

**WOLF CUB Home Constructor,** 1/2 in. Electric Drills, 99/6 carriage paid.

"THE LIVE STEAM BOOK," by "L. B. S. C.," price 12/6 post paid in U.K.

"TRACTION ENGINES WORTH MODELLING," by W. J. Hughes, price 12/6 post paid in U.K.

"THE AMATEURS LATHE," by L. H. Sparey, price 12/6 post paid in U.K.

**416 MOSELEY RD., BIRMINGHAM, 12**  
Grams: "Reevesco, Birmingham." Phone: CALthorpe 7554.  
"THE CHOICE OF EXPERIENCE"

**L. ROBINSON & CO. (GILLINGHAM) LTD.**  
Gillingham Kent

**MATRIC.**

WHY needlessly handicap yourself and watch other people winning success and security? Whatever your age, you can now prepare for the all important Matriculation Examination at home on "NO PASS—NO FEE" terms. Write now for our valuable "GUIDE TO MATRICULATION" which explains the new regulations, etc., and the easiest and quickest way to matriculate—FREE and without obligation.

BRITISH TUTORIAL INSTITUTE  
(Dept. 160), 356, Oxford Street,  
LONDON, W.1.

**"NO PASS—NO FEE"**

**AMATEUR LENS WORKERS**

All Supplies:  
GLASS — EMERIES — ROUGES  
CLOTHS — PITCH  
LAPS and LATHES

Lists on Request.

**MASON & GANTLETT LIMITED**  
3, ORFORD PLACE, NORWICH

**TARGET BLOWPIPES**

The "Target" FINE FLAME Gas Blowpipe (self-blowing) is ideal for all those small and delicate soldering and brazing jobs essential to model making. Fine intense flame easily melts small copper rivets. Soldering and small brazing jobs done in no time. PRICE 2s. 9d. each. POST FREE.

The "Target" FIERCE FLAME Gas Blowpipe (self-blowing). For soldering and brazing LARGER jobs. Gives a fierce roaring 4-inch flame. Guaranteed to melt 1/2 in. copper tube. PRICE (with full instructions) 3s. 6d. each. POST FREE. Retailers Enquiries Welcomed

**TARGET MFG. CO.,**  
Wollaston, Wellingborough  
(Dept. P.M.)



*Keep a*

**THOR**  
SOFT  
HAMMER

*at hand!*

COPPER  
RAWHIDE

Fitted with replaceable faces of compressed rawhide and pure copper these THOR Hammers never damage the work. Can also be supplied with both faces of the same material. Plastic hammers, and mallets of Rawhide, Lignum, Lead, Bronze and Rubber are also supplied.

THOR HAMMER CO., SALOP ST., BIRMINGHAM, 12. Phone: VICTORIA 0987/8

**REFILL YOUR OWN BALL PEN**  
VISCROID REFILL KIT

Post Free 3/8 inc. tax

Complete with Tool and Illustrated Filling Instructions.

CONTAINS SUFFICIENT INK FOR 15 LARGE REFILLS

Available in Blue, Red and Green. Trade Enquiries Invited.

**VISCROID INKS (P.M.)**  
6, Sherlock Mews, Baker St., London, W.1.

**RATCHET & REVOLUTION COUNTERS**

Ask for Leaflet No. 18/6

Speed up to 6,000 r.p.m.

**B. & F. CARTER & Co., Ltd., Bolton 5**  
Members of B.E.S.T.E.C. Organisation.

CLEAN COPIES "Practical Mechanics," Jan., 1941 to Dec., 1949 (less Dec., 1942). Offers, whole or part.

**L. BICKERTON,**  
Welsh Row, Alderley, Chelford, Cheshire.

Price 28 6s. 6d. Carr. Extra.

The 'Adept' Bench Hand Shaper

Length of stroke of ram, 3 1/2 ins.

No. 2B. H. Shaper, 6 1/2 in. stroke.

Price £15 0s. 0d.

Ask your dealer. Manufactured by:

Machine Vice 23/-

The SUPER 'ADEPT' LATHE

1 1/2 in. centres, 6 in. between centres.

The "Adept" 2 1/2 in. 4-Jaw Independent

Price 100/-

Postage and Packing, 2s. 3d.

Chuck. Reversible Jaws, 35/-

A Good Range of Accessories is available.

**F. W. PORTASS.**

ADEPT WORKS, SELLERS STREET, SHEFFIELD, 8

**ELECTRIC AMERICAN LOW-PRICED PAINT SPRAYER**

JUST PLUG IN AND SPRAY

Complete outfit, no extras to buy. Works off any 200-250 v. (A.C. only) light socket or plug point. Extra nozzle discs supplied free.

EASIER THAN A BRUSH AND TWICE AS FAST

**75!**

**J. BULL**  
(7PM), 246 High St., Harlesden, N.W.10

Telephone Sets. Consists of two combined microphones and telephones, 25ft. flex, gives perfect two-way communication; no batteries required, ready for use, cheapest form of intercom. Price 7/6 per set. Trade supplied. Send S.A.E. for list. Many other bargains.

**L. C. NORTHALL,**  
16 Holly Rd. Quinton, Birmingham 32.  
Retail Branch: 416, High St., Smethwick.

Mains Transformers UPRIGHT — DROP THROUGH AS ILLUSTRATED.

Two Types Only.

Guaranteed.

No. 1: 250-0-250v., 80 mA., 0-4-6.3v., 5 amp.

No. 2: 0-4-5v., 2 amp. No. 2: Same, but 350v. Both 17/-, post 1/- for 1 to 3.

**HILLFIELDS RADIO,**  
8, Burnham Road, Whittles, Coventry

**"THAMES VALLEY" BATTERY CHARGERS**  
2-6-12 VOLTS 1 AMP. 52/6 (Post Free)

These are brand new and are in enamelled steel cases with ammeters. Suitable for 200-250 volt A.C. mains.

**Thames Valley Products (P),**  
28, Camden Ave., Feltham, Middx.

# Free Guide - "Success in Engineering"

One of the following Courses taken at home in your spare time can definitely be the means of securing substantial promotion in your present calling, or entry into a more congenial career with better prospects.

## ENGINEERING, AERO, ETC.

Plastic — Radio — Aero Engines — Aircraft Design — Welding — Aerodynamics — Electrical Engineering — Television — Electric Wiring — Diesel Engineering — Generation and Supply — Works Management — Metallurgy — Refrigeration — Planning, Estimating, Rate-fixing — Time and Motion Study — Aero Inspection — Automobile Engineering — Sheet-metal Work — Engineering Draughtsmanship — Aero Draughtsmanship — Jig and Tool Draughtsmanship — Press Tool and Die Draughtsmanship — Structural or RIF Concrete Draughtsmanship — Sanitary Engineering.

## GENERAL

Gen. Cert. of Educ. — College of Preceptors — A.C.C.S. — A.C.I.S. — Aircraft Apprentice.

## MUNICIPAL SERVICE

School Attendance Officer — Handicraft Teacher — Registrar — Housing Manager — Sanitary Inspector — Weights and Measures Inspector — Inst. of Mun. Engineers — A.R.I.C.S. — L.A.B.S.S.

"PRACTICAL ENGINEERING" said—

We recommend all readers interested in improving their position to apply for a copy of this valuable book. "Success in Engineering" is not a pamphlet. It is a 132-page book, containing valuable and vital information on all branches of engineering. . . . There are many engaged in engineering who owe their success to The National Institute of Engineering.

The FREE GUIDE explains :

- Openings, prospects, salaries, etc., in Draughtsmanship, Inspection, and opportunities in all other branches of Engineering and Building.
- How to obtain money-making technical qualifications through special RAPID FULLY-GUARANTEED COURSES.

Write now for your copy of this remarkable publication.

A.M.I.Mech.E., A.M.I.M.I.,  
A.M.Brit.I.R.E., A.M.I.P.E.,  
A.M.I.C.E., A.M.I.Struct.E.,  
A.M.I.Mun.E., M.R.San.I.,  
A.M.I.E.D., A.F.R.Ae.S.,  
London B.Sc., Degrees.

Fully guaranteed postal courses for all the above and many other examinations. Fully described in the Free Guide.



## THE BUILDING BOOM— SECURE YOUR SHARE!

The Free Guide also gives particulars of our extensive range of modern Building and Structural Courses, Building Draughtsmanship, etc. The great post-war Building programme offers unlimited prospects to technically trained men.

## BECOME A DRAUGHTSMAN— QUALIFY AT HOME AND EARN BIG MONEY

Men and Youths urgently wanted for well paid positions as Draughtsmen, Inspectors, etc., in Aero, Jig and Tool, Press Tool, Electrical, Mechanical and other Branches of Engineering. Practical experience is unnecessary for those who are willing to learn—our Guaranteed "Home Study" courses will get you in. Those already engaged in the General Drawing Office should study some specialised Branch such as Jig and Tool or Press Tool Work and so considerably increase their scope and earning capacity.



## THE ACID TEST OF TUTORIAL EFFICIENCY SUCCESS—OR NO FEE

We definitely guarantee that if you fail to pass the examination for which you are preparing under our guidance, or if you are not satisfied in every way with our tutorial service—then your Tuition Fee will be returned in full and without question. This is surely the acid test of tutorial efficiency.

If you have ambition you must investigate the Tutorial and Employment services we are able to offer. Founded in 1885, our success record is unapproachable.

Why not fill in and post the attached Coupon NOW for further details and Free Authoritative Guide to openings in Engineering and Building? This book contains a mine of valuable and exclusive information and may well prove to be the turning point in your career.

PROMPT TUTORIAL SERVICE GUARANTEED

## FREE COUPON

To NATIONAL INSTITUTE OF ENGINEERING  
(Dept. 29), 148, Holborn, London, E.C.1.

Please Forward your Free Guide to

NAME.....  
ADDRESS.....

My general interest is in : (1) ENGINEERING (Place a cross against the branches in which you are interested.)  
(2) AERO (3) RADIO (4) BUILDING  
(5) MUNICIPAL WORK

The subject or examination in which I am especially interested is

To be filled in where you already have a special preference.  
(Id. stamp only required if unsealed envelope used.)

NATIONAL INSTITUTE OF ENGINEERING

(Dept. 29)

148, HOLBORN, LONDON, E.C.1

OVER SIXTY YEARS OF  
CONTINUOUS SUCCESS

SOUTH AFRICA: E.C.S.A. P.O. BOX 8417 JOHANNESBURG.

FOUNDED 1885—FOREMOST TODAY—OVER 100,000 SUCCESSES