

LARGEST CIRCULATION OF ANY WIRELESS PAPER.

Popular Wireless

Every Thursday

PRICE
3d.

No. 286. Vol. XII.

INCORPORATING "WIRELESS"

November 26th, 1927.

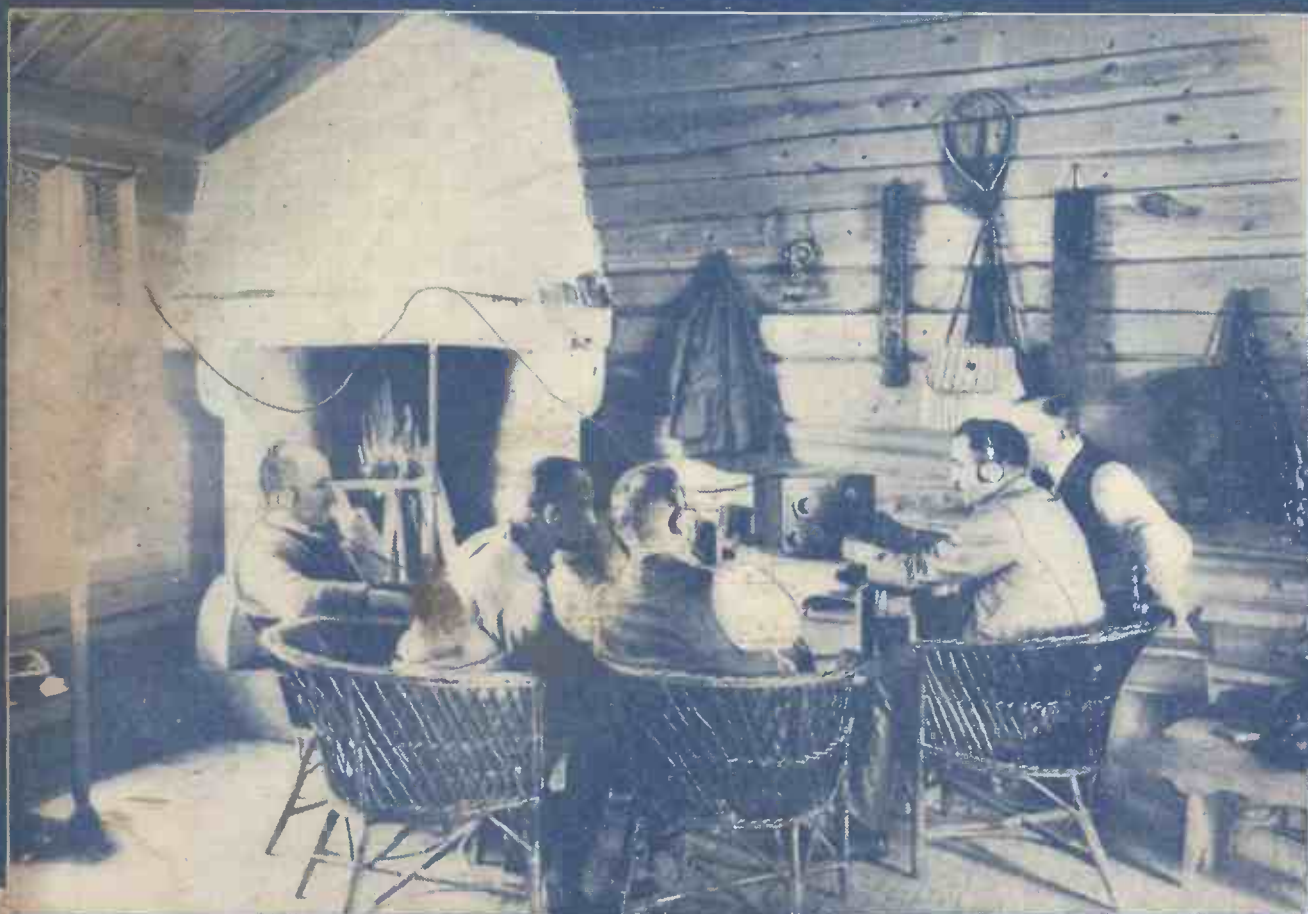

Special Features In This Issue

Wireless at Westminster. Distortionless Amplification?

THE "REGIONAL" TWO-VALVE SET

The B.B.C. Has Its Say. The Lure of Short Waves.

THE FIRST OF THE NEW "PROGRESSIVE" RECEIVERS

In the vastness of the snowfields in Norway wireless provides, as our cover photo illustrates, a welcome evening's entertainment to Winter Sports enthusiasts.

For sheer brilliant performance build this ultra-modern 5-valve receiver

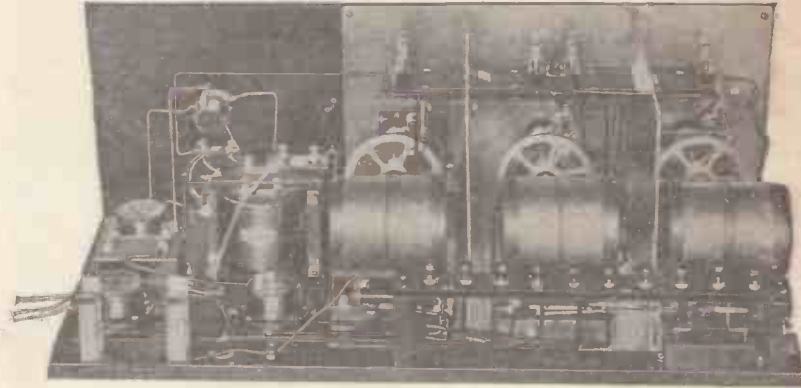

Interior view of the T.2 receiver.

If you want a receiver that incorporates the very latest developments in radio, build this 5-valver—the T.2, designed by Marconiphone. Incorporating two H.F. stages, using the wonderful Marconi S.625 Shielded Valves, it possesses extraordinary qualities of selectivity and sensitivity. Stations hundreds of miles away can be tuned in at full loud-speaker strength with complete stability, whilst purity of tone is doubly assured by the resistance and transformer-coupled L.F. stages.

Or there is the T.1, a 4-valve receiver, incorporating one Marconi S.625 Shielded Valve in the H.F. stage.

There are also four other circuits designed by Marconiphone for the home constructor. Easy to build, they bring the convenience and economy of—

OPERATION ENTIRELY FROM THE ELECTRIC MAINS

For A.C. Mains

- K.1. 3-valve receiver employing the famous K.L.I. valves.
- K.2. Similar to K.1, but in addition incorporates an H.F. stage.

For D.C. Mains

- D.P.1. 3-valve receiver—simple to construct.
- D.P.2. Similar to D.P.1, but gives greater range and selectivity by means of a neutralised H.F. stage.

FREE CONSTRUCTIONAL BOOKLET,
including blue print and full details will be supplied for any one of these receivers. Booklets, including blue print of the other five receivers, 6d. each.

MARCONIPHONE

To the MARCONIPHONE CO. LTD., 210-212, Tottenham Court Road, London, W.1.

Please send me **FREE** constructional booklet, including blue-print for circuit.....

I am also enclosing..... for the following booklets.....

NAME..... TOWN.....

ADDRESS..... COUNTY.....

No need to screen it

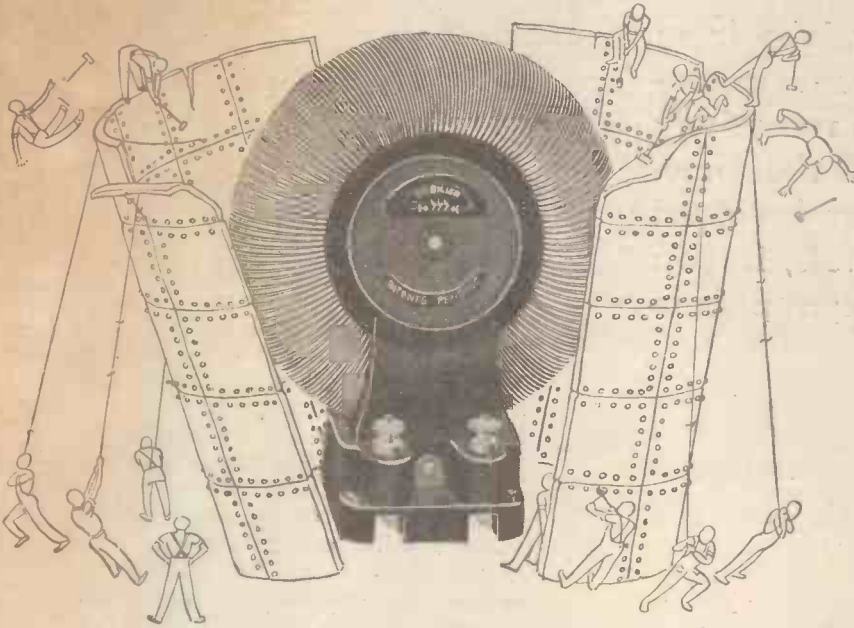

FIT Dubilier Toroid High Frequency Transformers to your set and do away with elaborate screening. You will gain efficiency in numerous ways because there will be no more of the eddy-current losses for which metal screens are inevitably responsible, your set will be more compact, more attractive in appearance, simpler to wire, and less expensive.

In addition, you will confer great stability on your set because Dubilier Toroids cannot "pick up" even powerful local oscillations. There is thus no risk of your fine tuning on distant stations being upset by direct pick up in the coil windings.

There is a wealth of information upon these products in the booklet shown here. In addition there are full instructions on how to make up five different valve circuits each possessing unique advantages. Don't be without your copy. Your dealer will hand you one, or, if he is out of stock, we shall be pleased to send you one, post free 3d.



Dubilier Toroids.
Long Wave 750
to 2,000 metres,
Broadcast 250
to 600 metres,
supplied with
detachable terminal
and soldering
base, each

10/6



DUBILIER DICTA



No. 1.



Valves are cheaper now but they are still valuable. An accident with your H.T. leads may ruin the emission of your pet valve even if it does not actually burn out the filament. If fuses could be relied upon to blow in time to prevent filament damage they might afford a solution to the difficulty.



The Dubrescon is not a fuse. It is a permanent safety device which positively prevents a rush of current from the source of H.T. supply. It does not in any way restrict the flow of H.F. current, and it costs only 6/-. To fit this "safety first" device in your H.T. lead is the work of a moment.



The dear old lady who visited our Stand at the Exhibition was apparently under the impression that we supplied complete sets. Or did she mean Loud Speakers! At any rate she asked us for "A wireless in a box that talks at you."

Probably she had seen on our Stand one of the "Toreador" Sets and, with unerring feminine instinct, had come to the conclusion that that was what everyone, including herself, really needed.



Incidentally the Toroids have a very important application other than in the H.F. Amplifying Stages of a receiver. They make highly efficient tuning couplers for crystal or valve sets as explained in the booklet.



A K.C. condenser shunted across the secondary in such cases gives true straight line frequency tuning independent of the constants of the aerial employed.

We shall have more to say on the Toroids next week.



Advt. of The Dubilier Condenser Co. (1925) Ltd., Ducon Works, North Acton, London, W.3.

WHAT YOU SAVE WITH THE LOTUS VALVE HOLDER

You save your valves from shock; you prevent microphonic noises in reception; you save yourself the time, trouble and expense involved by constant renewals, if you fit Lotus Anti-microphonic Valve Holders.

And now you can save money, too. Big price reductions have been made possible by big turnover.

Lotus Valve Holders are still the best you can buy—perfectly finished and carefully made from the finest materials. At their new prices they defy competition.

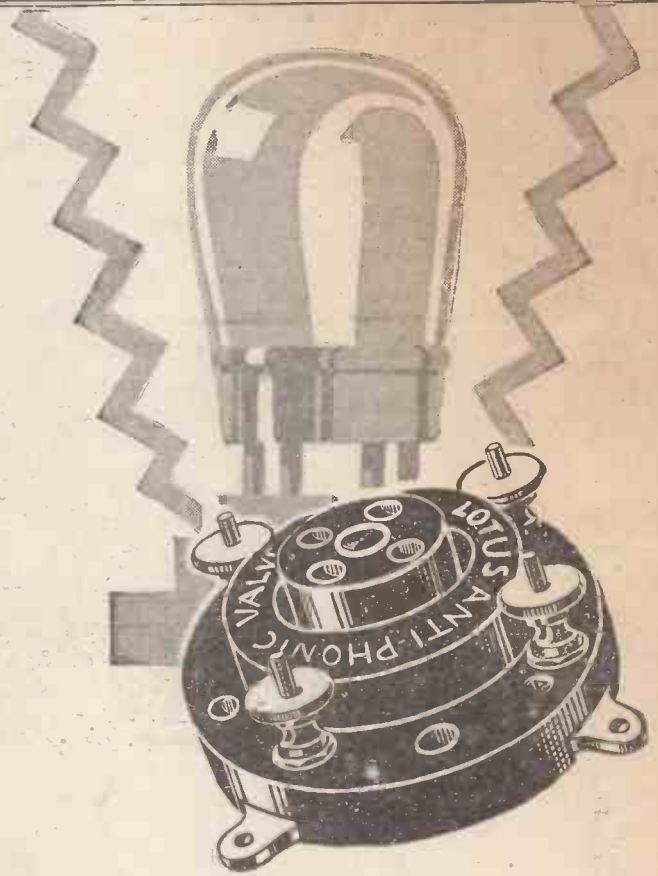

Used and recommended by the important set makers of Great Britain, and for the famous MULLARD "RADIO FOR THE MILLION" Circuits.

LOTUS
 BUOYANCY
VALVE HOLDER
 ANTI-MICROPHONIC

NEW PRICES:

Without Terminals . . . 1/6

With Terminals . . . 1/9

Made by the makers of the famous Lotus Remote Control, Vernier Coil Holders, Jacks, Switches and Plugs.
GARNETT, WHITELEY & CO., LTD.
 "Lotus Works" - Broadgreen Road, Liverpool

ABSORBS SHOCK -- ELIMINATES MICROPHONIC NOISES

Getting better results from 2 volts

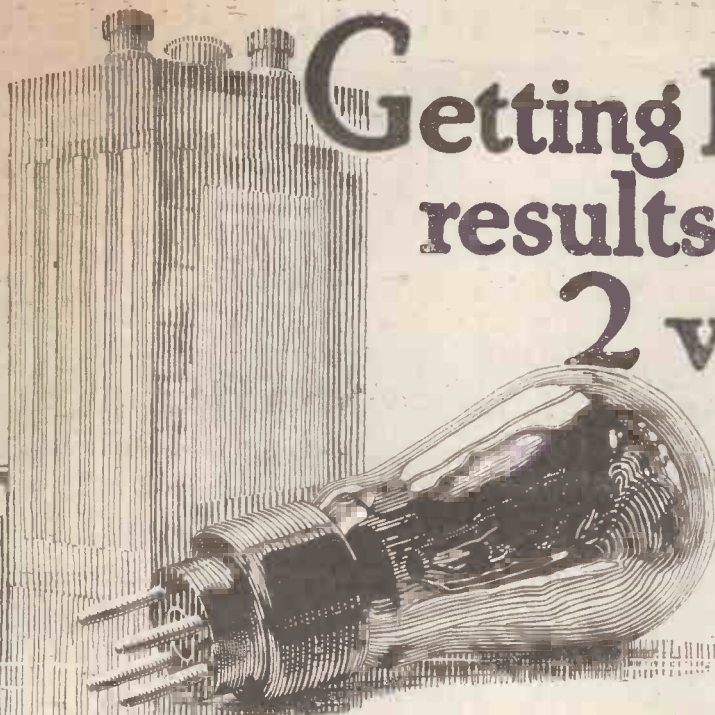

B. 210H

R.C. and H.F.

Fil. Volts... 2

Fil. Amps.. 0.10

Max H.T. V. 150

10s. 6d.

B. 210L

General Purpose

Fil. Volts... 2

Fil. Amps.. 0.10

Max H.T. V. 120

10s. 6d.

B. 215P

Power

Amplifying

Fil. Volts..... 2

Fil. Amps.. 0.15

Max H.T. V. 120

12s. 6d.

The above prices are applicable in Gt. Britain and N. Ireland only.

WHEN we say that the B.T.H. Nickel Filament Valves are superior to all other 2-volt valves, we are not referring merely to subtle improvements in construction or characteristics. We mean that the new valves give results which, to the average listener as well as to the critical expert, are quite obviously better in volume, tone and length of service, than those given by any other 2-volt valves.

To get the very best from your 2-volt accumulator you must use Nickel Filament Valves. But don't take our word for it. Try them in your set. You will be delighted and astonished at the wonderful improvement in reception—a result that will more than justify the cost of the change.

Your dealer holds adequate stocks of these valves.



VALVES

NICKEL FILAMENT

Made at Rugby in the Mazda Lamp Works.

The British Thomson-Houston Co., Ltd.

**“MUSIC HATH CHARMS TO SOOTHE
THE SAVAGE BREAST.”**

“The VIKING IV more than proves the truth of this proverb,” says our friend on the left. “Its quality is wonderful.”

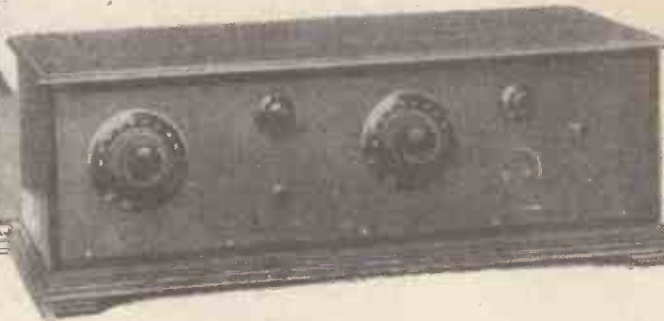

THE VIKING IV

Fully described in the special CHRISTMAS DOUBLE NUMBER
of the December Issue of

“MODERN WIRELESS”

together with a full-size

SHILLING BLUE PRINT FREE

• • • •

Place an order with your Newsagent NOW, and on no account miss getting your copy of the Christmas Double Number of “Modern Wireless” on Sale December 1st.

Besides the full-size blue print and many special articles of interest to all amateurs the issue will contain the first announcement about a new 1928

SOLODYNE RECEIVER.

“Modern Wireless” has secured the rights to publish full details of a Solodyne Receiver from Mr. John Scott-Taggart, A.M.I.E.E., F.Inst.P. An important preliminary article about this famous receiver will be found in the December issue.

ORDER YOUR COPY NOW.

50
FOR
PARTS

**2 HOURS
TO BUILD**

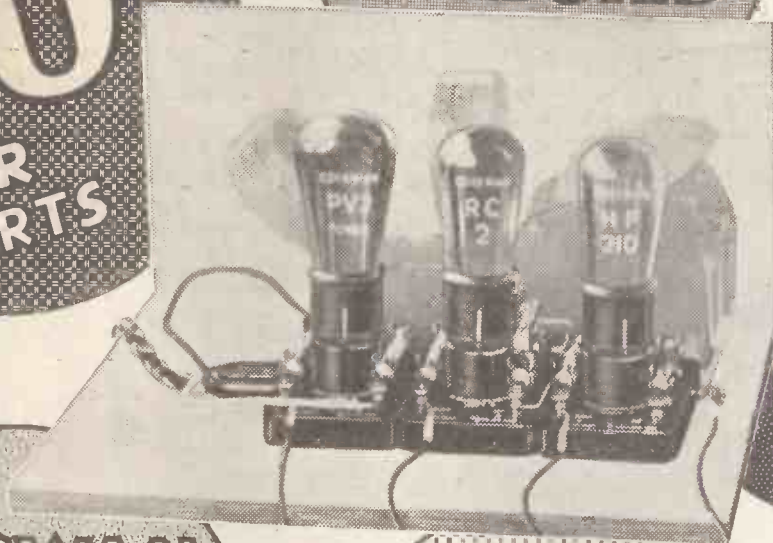

**BOOK
AND
BLUE-
PRINT
FREE**

**EDISWAN
VALVES**
*Clearer
Strongest
Last the
longest*

**VALVES
ESSENTIAL
for BEST RESULTS**
**H.F.210 · R.C.2
P.V.2**

Ask your dealer for particulars of the New **EDISWAN Local Station Eliminator.** Price 25/-.

To **THE EDISON SWAN ELECTRIC CO., LTD.** (Publicity), 123/5, Queen Victoria St., London, E.C.4. P.W. 26.11.27

Please send, post free, presentation copies of the New R.C. Threesome Instruction Book and Blue Print.

NAME

ADDRESS

V. 70.

EDISWAN

NEW R.C. THREESOME

Cossor

*The valve which
made possible the
wonderful Cossor
"Melody Maker"*



The Sensation of the Season!

THE wonderful Cossor "Melody Maker" gets concerts from France, Holland, Germany, Spain, Italy and Switzerland. Also full range of B.B.C. programmes. Anyone can build it. No soldering. No wiring. Success guaranteed. Costs little to build. Send coupon for chart showing new constructional system which removes all difficulties.

THE amazing success of the wonderful Cossor "Melody Maker" is due largely to its splendid Cossor Valves. Its superb tone—its uncanny ability to sense out distant Broadcasting and to re-create it in full volume—with all the warmth and colour of the original transmission—is due to its Cossor Valves. All who have heard the "Melody Maker" have been thrilled with its performance—with its exquisite purity—with its glorious volume. Use Cossor Valves in your Receiver and get all the advantages of the super-efficient Kalenised filament—purity—volume—long life—low current consumption. In a wide range of types for all voltages from 10/6 each.

FREE!

To A. C. Cossor, Ltd.,
Highbury Grove, London. N.5

Please send me free of cost your constructional system "How to build the Cossor "Melody Maker.""

Name

P. W.

Address



Popular Wireless



Scientific Adviser :
 Sir OLIVER LODGE, F.R.S.
 Editor :
 NORMAN EDWARDS, M.Inst.R.E., M.R.S.L., F.R.G.S.
 Technical Editor : G. V. DOWDING, Grad.I.E.E.
 Assistant Technical Editors : K. D. ROGERS, P. R. BIRD,
 G. P. KENDALL, B.Sc., A. JOHNSON RANDALL.

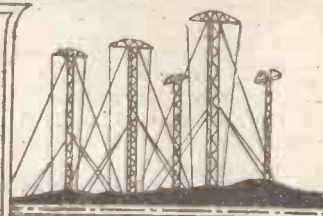

RADIO NOTES AND NEWS.

Fireside Radio—Beware!—Empire Broadcasting—A Hopeful Sign—The New Amateur—Bombay Hears Albert Hall—Chitos in Sydney.

Really Fireside Radio.

THE cold snap which prevails as I write these Notes, causes me to realise, by the absence of a goodly number of thermometric degrees, that my set might with great comfort be nearer to the fire. The thing is all right for straight listening, but for "searching," when I have to stay by it, I think I might as well be at the North Pole. I want a one-dial control, with the dial screwed to the arm of my fireside chair. Inventors! There's the germ of an idea

Beware!

I HEAR that there is a bogus Post Office wireless inspector loose amongst us. He gets into the house on the score of wireless and when he goes he leaves you spoonless or jewelless—which is a score for him! But there is an easy way to detect this fraud. You have only to say to the next alleged P.O. inspector who calls, the word "Supervisor." If he then shows fear or disgust, he is *pukka* Post Office. Or the word "Rugby," when, if he is a real P.O. wireless man his face will light up with honest pride. Try it!

Empire Broadcasting.

5SW is now well under weigh, and I have great hopes of it, because of the collaboration with the B.B.C. of the men who worked out the short-wave Beam system and set it going so successfully. The other day a cabled inquiry as to its transmission times was received from Paris, and it is safe to assume that the ears of the world are focused, so to speak, on Chelmsford.

A Hopeful Sign.

W. M. (Warlingham) tells me that on November 5th, while receiving 2XAF on a Reinartz Two, that station announced, "We have successfully re-broadcast 5SW, Chelmsford, England, this afternoon and evening at fair strength, fading slightly." So there you are! Perseverance, practice, and a little luck—and overseas Britons will get their hearts' desire. Who said "service"? Why, the men in the outposts of Empire will be satisfied and inspired if they can get Big Ben and a cheery English voice now and then. I know, because I, too, have been isolated in foreign

parts for years together and used to feel homesick when I heard the North Foreland working with ships.

"The Humour of It."

I HAVE just read a story of a listener who, one wet Sunday evening, when the greater part of his county was flooded, turned on his set and had the pleasure of hearing a part of an oratorio—the Israelites' song of rejoicing for deliverance from a drought. The words were, "Thanks be to God, for He laveth a thirsty land."

B. E. A. B. C.

THE British East African Broadcasting Co. has been formed, with Lord Delamere as Chairman, and Commander L. M. Robinson, Managing Director. So far as my present information goes, the times

valve Reinartz he gets from 25 to 30 stations, almost all of which, except Swansea, arrive with greater power than any B.B.C. station, Langenberg being louder than 5GB. He gets Oslo as loud as 2LO, and Stuttgart louder than Swansea; Milan louder than Manchester, and Berlin louder than Newcastle. This must be a case of "skip distance," surely, for 2LO is a pretty fair traveller. Mountains, too, are the dickens on wireless.

"Blind" Licences.

THE issue of free licences to the blind began on January 1st, 1927. In one month 2360 had been granted. In two months the total was 4404, and by October 1st it had increased to 9,150. The Braille edition of the "Radio Times" now has a circulation of 1,500.

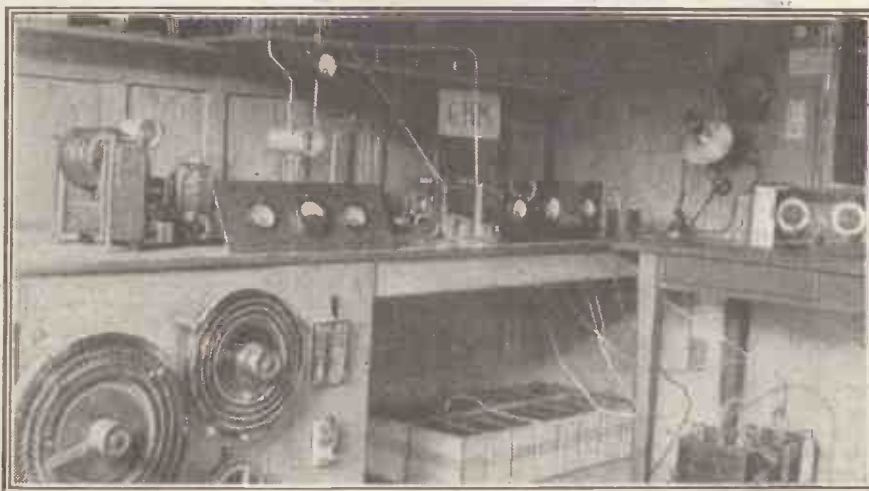

The amateur station, 6HM, operated by Mr. C. C. Buokle, Carbury, Grosvenor Road, Richmond, Surrey.

of working will be from 1 to 2 (p.m.) and from 6.30 to 10.30 (p.m.). All good luck to the enterprise. They will need it, what with the X's and so forth.

"Punch."

APROPOS my recent note about the lack of punch in B.B.C. signals in certain districts, W. T. of Godrergraig, Glam., tells me that with his Two-

"Padded Chamber" Music.

IN a very fair letter, which deserves a fair show, E. H. B., writing from a Glasgow hotel, puts in several words for Chamber Music. He says that I, having heard some C.M. that I do not like or understand, condemn all compositions under that heading. He asks if I have ever given C.M. a fair trial; he says I am not
 (Continued on next page.)

NOTES AND NEWS.

(Continued from previous page.)

sufficiently tolerant of it, and offers to cover my expenses if, having bought the Columbia records of the Trout Quintet, I consider I have wasted the money.

Why I Shun It.

FIRST, I do not listen to *any* music in order to "understand" it, nor does the average listener. We judge it mostly by its response to our individual ideas of sweetness, and by its sensuous appeal. My experience is that music which requires to be understood is not popular, and what is not popular is obviously that which the majority consider they do not like very much. I do not condemn all C.M., but as I have heard so little of it which appeals to me with the force of, say, the overture to "The Mastersingers," I think it might be replaced for something from which I get more pleasure.

And, Thirdly.

I HAVE tried C.M. many times. When it has no melody it is an infernally silly row, and when it has a melody it drones on and on like a musical box that can't stop. I speak generally. Here and there one gets a happy moment, and then suddenly some tom-fool bit of twiddle work is savagely thrust upon a sedate little tune. H. D. W. (Watford) says he thought Bela Bartok was a record played backwards. My sentiments! Dear E. H. B., let us respect each other's tastes and each grouse as he pleases. C.M. is *not* popular—and there are reasons. I regret I cannot accept your sporting offer, *because I do not possess a gramophone.* I am a radio listener. Chcerio!

Drastic?

NOT long ago at the Manchester Athenæum Debating Society the Chairman of the Manchester Association of Radio Societies moved, "that this meeting considers the administration of the B.B.C. is in entirely wrong hands and the policy hitherto adopted with regard to programmes is not wholly in accordance with the general public taste." It was carried unanimously. A bit hot, though, wasn't it? Especially when one realises that the general public's taste has as many facets as a fly's eye.

The New Amateur.

MR. DOWDING asks me to say that he has received so many letters expressing appreciation of his articles for the new amateur, that if he were to undertake to reply to the writers individually he would have no time to write any more of the articles. Therefore, he extends his sincere thanks to all his readers for giving him such pleasant "proof of the pudding."

Radio's Latest Recruit.

BIRMINGHAM is credited with having produced the first radio night-watchman, who lights his lamps, banks up the coke fire, and then slings his aerial and gives himself up to the joys of Daventry. One hopes that his concentration on the "talks" will never cause his vigilance to relax so much that somebody is allowed to fall down the hole in the road, or his coffee to boil over.

Short-Wave Note.

THE Associated Radio Company is arranging to build a short-wave broadcasting station for Melbourne, 3 AR, which will use a wave-length of 55 metres and, at first, a power of a quarter kilowatt. We shall be delighted to report on its reception by our ever-hungry short-wave enthusiasts. By the way, the new station at Huizen, Holland, built by the Protestant and Catholic Radio Group, was supposed to have been inaugurated last month. Anyone heard it? Wave-length, 1,840 metres. (That is not a short wave! Is it not? Then tune for Rugby and see.)

Fans in Egypt.

SERGEANT N. A. NORCROSS and Corporal W. E. Corbett, of No. 1 Wireless Company, Egypt Signals, Polygon, Cairo, beg to announce that they have erected two short-wave C.W. transmitters. Wave-band,

SHORT WAVES.

A wireless invention enables a piano to be used as a loud speaker. This is really no help, because when the piano is not being used as a loud speaker it can still be used as a piano.—"London Opinion."

FLUENT.

Wireless, it is said, has added hundreds of new words to the language. Most of them, of course, are used when the wretched thing won't work.—"Sunday Pictorial."

We always pin our faith to a component that has the dealer's name on it, but I have my doubts whether my friend did the other day when he picked up a coil and remarked that it was a "Frost"!

Short-sighted lady to motor-car salesman: "Can you guarantee to get Daventry Junior on it?"—"News of the World."

THE STUD NUISANCE.

Motor-cars, ships and aeroplanes can now be entirely controlled by radio.

An inventor is, we understand, now concentrating on a radio-controlled collar stud, which will emit a Morse signal when anywhere but in the shirt-collar.

"One of the latest German inventions is a rod, fixed up on a sort of wireless receiver which, when a hand is waved round it, produces musical sounds resembling a violin," we read in a London newspaper.

But that's not original; what about the sounds produced when rod and hand were waved at school?

Radio talks are all right in reason, but I think the average man would willingly dispense with a few of them in favour of something a trifle more entertaining and cheerful. The only point in their favour is that your accumulators last longer!—"Yorkshire Evening Post."

A scientist is of opinion that there is much to be said for the progress of radio this year; but, of course, we couldn't print it here.

"Standard English is an ephemeral thing; but broadcasting is the most powerful instrument that has ever been available for investigating standard English. Perhaps it may do more. It may help to stabilise English the world over."—George Bernard Shaw.

"Do not judge the B.B.C. by the 'Children's Hour' or variety entertainments. I know they are dreadful. I have not much opportunity of listening in at my own house, but there are occasions when I cannot get across the room quick enough to turn the set off."—Sir John Reith (Director-General of the B.B.C.).

Well, well! That's "Home Truth" with a vengeance!

20-45m. Calls, A 1 WT and A 2 ES. Normal working hours 01.00 to 02.00 G.M.T. and 03.30 to 04.30 G.M.T. Input about 100 watts. These gallant key-pounders would like reports on their signals and would not disdain tests with all-comers.

The B.B.C. Birthday.

HEARTIEST CONGRATULATIONS to the B.B.C. on the completion of its fifth year, and on the special programme arranged, I believe, by the "Brothers Eck." The take-off of a certain well-known broadcaster was excellent, and I especially enjoyed the potted "play of the future." A thoroughly good bit of fun and I thank all concerned for a most amusing hour.

Bombay Hears Albert Hall.

OUR old friend, Gerald Marcuse, of 2 N M fame, showed me the other day a Bombay cable he received in connection with the broadcasting of the Armistice Festival at the Albert Hall. It read, "2 N M's Transmission received—not strong—fading bad—nevertheless very enjoyable—nobody Bombay succeeded getting Chelmsford."

Rather a fine feather for 2 N M's cap, what?

Short-Wave Stations.

HERE are a few telephony stations. Java, AN H, 17-4, 27-32; Berne, EH 9 OC, 32; Johannesburg, JB, 32; Melbourne, 3 L O, 33-4, 29-8; Eindhoven, PC J J, 30-2; Radio Malabar, PC G, 17; Cincinnati, WL W, 52-02; Atlantic Broadcasting Corporation, New York, WA B C, 64; Nauen (Germany), A G A, 13-5 and others. G. Marcuse, Caterham, 2 N M, wave-length 32.4. Chelmsford, B.B.C. Experimental, 5 S W, 24 metres. I have more to follow.

Chitos at Antipodes.

BLESS me, how "P.W." travels! That Chitos, born of a misprint, has now passed into radio history. B. A. V. G. of Sydney, N.S.W., sends us a coo-ee of praise for Chitos, he having made a one-valver. He gets 3 L O and 3 A R, Melbourne, 400 miles; 4 Q G, Brisbane, 500 miles; 7 Z L, Hobart, 700 miles; 5 C L and 5 D N, Adelaide, 800 miles; and 2 Y A, Wellington, N.Z., 1,480 miles. He thinks Chitos is "dinkum." Good for the digger! When is he going to pick up Britain?

"On Dit" from Paris.

THE Paris radio exhibition, which closed on November 13th, had exhibits by about 238 firms. It revealed a deplorable lack of fine cabinet work, which is surprising, when one remembers what the French can do in that respect. Further, portables seem to be some two years behind our own models, and are not much more than experimental. But fancy being able to get a six-valve Supersonic, "all in," for the equivalent of £21!

Personal Note.

GOOD-MORNING, readers all! (Cribbed from Sir Walford Davies.) This is to announce that the front-door mat is choked with letters, mostly from Valve Baronets who get Australia on half a valve, etc., etc. I will sort the sheep from the goats, and the Baronets from the Barons, and deal with them as soon as possible. Patience, *mes amis*. "P.W." is a weekly, thank goodness, or I should be six months behind. By the way, I have not had a letter from a Knight of the Cat's-Whisker for several months. Can it be that the reduction in valve prices has exterminated the species?

ARIEL.

Wireless at Westminster



NOW Parliament has re-assembled more will be heard of the proposal for introducing the microphone near the Treasury Bench.

Any proposal for increasing the popularity of Parliament is to be welcomed, for a keener interest in the House of Commons deliberations is bound to be an advantage to the community generally. A democracy politically enlightened and fully well informed is likely to fulfil its duties of citizenship more efficiently than a democracy frigid with ignorance and apathy.

The question will naturally arise as to the extent to which it would be possible to broadcast the proceedings at Westminster. Anyone familiar with the procedure will readily realise that the whole of the proceedings could not be transferred through the ether to the listening millions. If this were done by way of trial the British public would soon realise what they owe to the reporters and sub-editors in polishing the ragged and disconnected sentences of some of the occupants of the green benches.

Very Poor Oratory

Although, thanks to the skilled work of the Hansard official staff, the verbatim reports read with clarity and smoothness, many Parliamentarians would not appear to advantage were their speeches to be heard in their raw state. Except in the case of a select few, the speaking fails to rise to a high level—much of it is on a level with the oratory of a small provincial council. The phrasing is generally of a colloquial character, and in some cases the speeches would be unintelligible but for the finished touches of the reporters. Even in the case of the Ministers on the Front Bench it is rarely that the same standard is reached as was customary in the days of Disraeli and Gladstone. There are, of course, exceptions, such as the speeches delivered in both Houses on the worth and work of the late Lord Curzon. There is now not the same attempt made to prepare set orations, whilst piquant epigrams are infrequent, and apt quotations from the classics an unknown quantity. Some excellent impressions of the rotund oratory

Should Parliamentary proceedings be broadcast? If so, how much could the listener stand? Westminster debates are not so interesting as many might imagine.
By A PARLIAMENTARY CORRESPONDENT.

formerly heard within the walls of St. Stephen's were given at 2 L O, when the 18th century programme broadcast included one of Edmund Burke's sonorous orations.



Capt. Ian Fraser, C.B.E., the well-known radio M.P.

Another objection against dealing with the whole of the proceedings from the time when the House of Commons assembles at 2.45 each day until the rising hour at 11 p.m., is that wireless enthusiasts would profoundly object to listening to a stodgy debate on the question of the alteration of the burgh boundaries of a Scottish area, in substitution of a programme of the Queen's Hall promenade concerts. The time when the

wireless is most in use is generally the period of dullness in the House of Commons.

The first hour of the sitting is devoted to questions. This is the period when the clever heckler uses his wit and resource against the official reserve of the Minister questioned.

"Deadly Dull" Procedure

The close observer is amused at the clever way in which an Under-Secretary will read a long reply, couched in the most courteous and nebulous language. Before the inquirer can fire in a supplementary query, the Speaker has passed to the next one on the list. Except when an important pronouncement is made by a Minister this part of the sitting would prove deadly dull and perfectly puzzling. The following is the procedure. The Speaker takes the questions in rotation and calls out each number in succession. The Minister's reply is sometimes made as follows: "The answers to the first and second parts of the question are in the negative, and the third part consequently does not arise." A reticent Under-Secretary may use this formula: "In reply to the Hon. Member I must refer him to the answer given to a similar question raised by the Member for Loamshire on March 25th." Listeners would not gain much enlightenment or inspiration from replies of this character.

One Good Effect.

The whole project seems to narrow itself down to limiting the broadcast to the delivery of an important speech by one of the Ministers, or the closing speeches on some great national debate.

If this were done it would be welcomed by the Press Gallery, the members of which suffer from the indistinct utterances of some of the Front Bench occupants on both sides of the House. These offenders would have to speak with a greater distinctness before the microphone, and there would be less strain on the arduous Gallery reporters. It would then be possible to hear without any difficulty Mr. Ramsay MacDonald, Mr. Snowden, and others who have not yet succeeded in mastering the acoustic properties of the House of Commons.

THE B.B.C. HANDBOOK is a commendable production reflecting much credit upon those who are responsible for its compilation. Printing, paper and general "get-up" attain a high standard, and the heavy sprinkling of photographic and other illustrations have added considerably to the general interest. The price of 2/- is very low, and is only made possible by the very large sale which will undoubtedly be obtained.

The first question the reviewer asks himself is: "What is the purpose of this book?" It is apparently an endeavour by those responsible for the British Broadcasting Corporation to tell the public just what they are doing, how they do it, and the motives which actuate them. The introduction by Sir J. C. W. Reith, Director-General of the B.B.C., is characteristic of one who exerts such a powerful influence over the service.

Too Much "Education"?

As one reads Sir John's article one is driven to the conclusion that in Sir John's mind the first duty of a broadcasting service is to instruct and educate. As an example there are many, we imagine, who will question the following: "Of the potentialities of radio for *instruction* for adults and children in continuous courses or by way of single appetisers, there is no room here to speak. *The mere fact that such a medium is there—able to override distance, to overcome inequalities of teaching ability, to broadcast seed on a wind which will take it to every fertile corner—imposes the duty of taking advantage of it.*" (The italics are ours). Substitute the word "propaganda" for "instruction" and see what would be involved! The logic is the same in each case.

Excellent articles on the old and the new régime, the administrative system, the programme policy (including most valuable analyses of a typical winter month) and other allied matter, come quite suitably

THE B.B.C. HAS ITS SAY.

A review of the handbook recently published by the B.B.C.
By A SPECIAL CORRESPONDENT.

in such a volume and will do much to enlarge the public mind on such matters. The article entitled "Listeners' Criticisms" is, perhaps, rather patronising in tone: "The B.B.C. has not infrequently benefited by honestly constructive criticism which is always welcome to us," and contains little real information. Again, take for example the opening sentence in "Chamber Music in Broadcasting": "... Until these days of wireless in the home the average man completely shunned that mysterious something which for an unknown reason was called 'Chamber Music.' He had probably never heard any of it; it was something remote, intangible, incomprehensible to all but a few mad enthusiasts who, for a quite inconceivable reason, would sit for an hour on end in an uncomfortable seat listening to four fiddles to the complete disregard of anyone else who happened to be present. . . ." The B.B.C. must drop this attitude, which crops up in more than one article in the volume under review, and, quite incidentally, is frequently heard from the microphone.

The Regional Scheme.

A thirteen-page article entitled "The Regional Scheme" calls for some criticism. After wading through it and concentrating one's attention with the strongest effort, the reader is left in such a state of mental confusion that he seems to know even less about the regional scheme than before! One would hazard a guess that the B.B.C. itself is not quite sure where it is with regard to this scheme, and it would have been better to say nothing whatever.

Readers of POPULAR WIRELESS will find much more interest in the many valuable technical articles, as well as in those of a semi-technical nature such as "Sound Balance and Control." Articles on the London studios, the positions of performers in the various productions, broadcasting transmitters, studio construction and technique, and so forth are valuable.

An Injustice.

The author of the article entitled "The Broadcast Receiving Set," when dealing with home construction, makes a peculiar error in saying that one's panel may be wood, or "best quality ebonite *preferably with a matt finish.*"

This is doing an injustice to the large number of really excellent polished panels now sold. In the early days of wireless, when ebonite was cut from a sheet as required, and special ebonite was not made for radio panels, the polish had to be removed as it had been obtained by rolling the ebonite during manufacture in contact with a sheet of tinfoil, which left a leaky surface.

All the branded radio panels now sold are leakage free and nearly all have polished surfaces. To remove this is to spoil the appearance and gain no advantage whatsoever.

These are minor criticisms, however, and on the whole the book is exceedingly well done. A feature which alone justifies the price, and which makes it a handbook which should be on the table of every home constructor is the section entitled "Foreign Identification Panels." Particulars are given of the large number of broadcasting stations, the wave-lengths, frequencies, power, approximate distance from London and, most important of all, the call and any little peculiarities which characterise the station. We have already found the book most useful for identifying foreign stations by these little peculiarities.



This is the transmitting outfit of the famous Sydney Station, whose short-wave broadcasts have frequently been heard in this country on simple, inexpensive sets, such as the "Sydney" Two, which was recently described in "P.W."

The PROGRESSIVE ONE



IN this article I am going to describe the construction of an efficient and modern one-valve receiver, and in successive articles I am going to show how this set can be extended stage by stage until it forms a high-class four-valver capable of receiving

COMPONENTS AND MATERIALS REQUIRED.

- 1 Piece of hard wood (such as mahogany) for panel, 17½ in. × 6¼ in. × ¾ in.
 - 1 Piece of hard wood for baseboard, 17½ in. × 9½ in. × ¾ in.
 - 1 Terminal strip (ebonite), 8 in. × 2 in. × ¼ in.
 - 1 Terminal strip (ebonite), 2½ in. × 2 in. × ¼ in.
 - 1 3½-in. length of 3-in. tubing (ebonite, Pirtoid, or cardboard).
 - 2 Ounces of 26 S.W.G. double-cotton-covered wire.
 - 8 Terminals.
 - 1 Valve holder.
 - 1 Variable condenser, .0005 mfd. capacity, with vernier control (any good make).
 - 1 Variable condenser, .0003 mfd. capacity (any good make).
 - 1 H.F. Choke (see text).
 - 1 Variable resistor (for filament control) baseboard mounting (Lissen, Igranic, or similar type).
 - 1 2-meg. grid leak (Dubilier, Igranic, Lissen, Mullard, etc.).
 - 1 .0003 mfd. fixed condenser (Clarke, Mullard, Lissen, T.C.C., Dubilier, etc.).
 - 2 Single-coil holders for baseboard mounting.
- Tubing for coil former, terminals, wire, screws, etc., as per instructions given in the article. You should carefully read the article before actually purchasing any of the above components.

quite a number of stations on the loud speaker. Now this is going to be no "hodge-podge" unit set. When it has grown up to its H.F., Det., 2 L.F. magnificence, it will bear no signs of its growth; it will be just as neat and compact as the best of conventional four-valvers, but it will be 100 per cent efficient, for no addition must be made during its building at any one period until the existing assembly is operating properly.

As I said before, at first we will have a

Here we have something entirely new in radio-set construction, and it is impossible to explain in a few words exactly how much fresh ground is broken by this original scheme. The idea will appeal to all classes of radio enthusiasts from the veriest tyro upwards and in five instalments the construction of a One-Valver, H.F., Det. Two-Valver, Det., L.F. Two-Valver, H.F., Det., L.F. Three-Valver, Det., 2 L.F. Three-Valver, and H.F., Det., 2 L.F. Four-Valver receivers are dealt with, and in easy stages a one-valve set grows up to four valves. How is all this done? It is not a unit system. Read this first article, which describes the construction of an efficient one-valve set, and you will appreciate the novelty of the "Progressive" method of receiver construction. By G. V. DOWDING, Grad. I.E.E. (Technical Editor.)

one-valver and this will be tested and made to work as a good one-valver before the next step is taken. Then this one-valver will be extended to two valves and then to three valves, and, finally, to four valves. If a constructor desires to stop at two valves he can do so, or, if he likes, he can miss a stage. It won't matter a bit, for at any point the set will be quite complete. For instance, many constructors might want but two—a detector and one L.F. amplifying valve for loud-speaker work on the local station. If so, there is no reason at all why they should not skip the addition of the H.F. valve—which comes next week—wait for the addition of an L.F. valve and then gracefully retire from the series.

Pay While You Listen!

Obviously, too, those readers with rather shallow pockets can regard the scheme as a sort of "wireless set by instalments" stunt, with the added advantages that they not only "pay while they listen," but that if they cannot face the financial drain—not a very large one, by the way—of the whole four valves, they can leave off at either two or three valves.

(Continued on next page.)

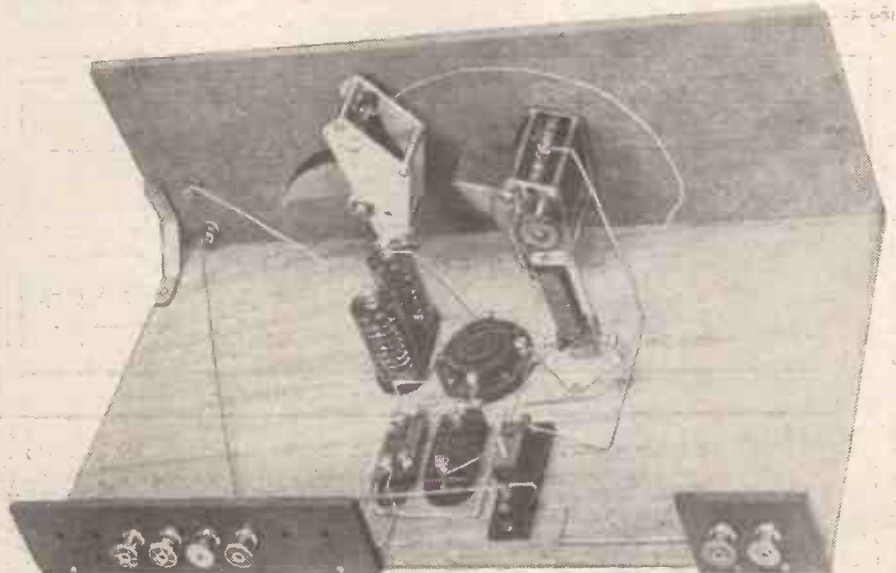

This is the back-of-panel view of the "Progressive" One. Rather a lot of wasted space, isn't there? But next week you will be shown how this set can have an H.F. stage added without altering a single lead or shifting one component. You can cut the panel and baseboard down if you want to stop at one valve.

The PROGRESSIVE ONE.

(Continued from previous page.)

Similarly, constructors who have hitherto thought that the construction of a multi-valver is something to be tackled only by the advanced amateur can follow me stage by stage through this series of articles and learn how really simple such a task can be.

Now just let me briefly describe the programme so that everything is quite clear before we start. This week I am describing the construction of a one-valve receiver with Reinartz reaction. With no alteration in existing wiring, and with but the simple addition of a few components, this will become next week a:—

Two-valve receiver employing one stage of H.F. amplification suitable for long-distance telephone reception. In a following week this will grow quite unobtrusively into a:—

Three-valve receiver employing a stage of transformer-coupled L.F. amplification. This set will then be extended so that it becomes a:

Four-valve receiver employing a stage of choko or resistance-capacity coupled L.F. amplification.

Then, finally, will come the one or two little refinements which will make the four-valver everything that the most ambitious constructor could desire.

Truly Elastic.

Now, it will be appreciated that it will be necessary for us to start work with a panel and baseboard large enough to take the complete outfit if we would evade the horrible business of stringing up separate panels. But by using a wooden panel and carefully arranging the lay-out of components, I have made it possible to cut down, if a halt is made at one, two, or three valves. All that is necessary is to shift up the terminal strips—a very simple task. Additionally, by making the baseboard rather deep I think readers will agree with me that the panel will not look huge even if it is not cut down and even if it harbours but two valves.

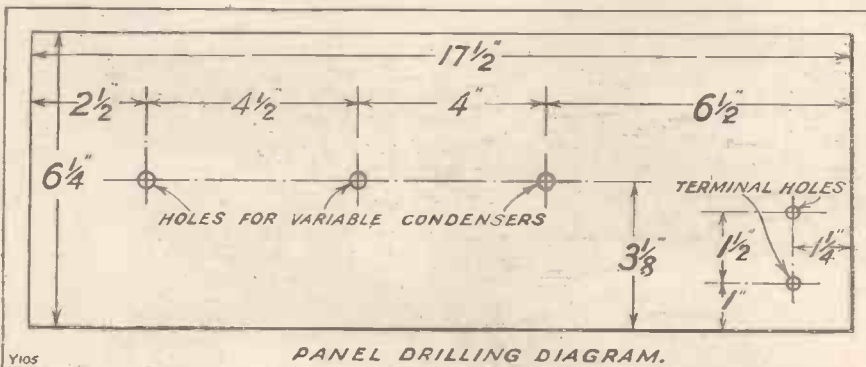

Of course, I am really against any panel snipping for, although the constructor might at one time be perfectly convinced that he will never need or desire to go further than three valves, there may come a day in the distant future when to be able to do so would be extremely gratifying.

And here I must point out that I have already built the four-valver stage by stage,

and have had each stage photographed and all the diagrams drawn, so that readers need have no hesitation in embarking on the voyage of construction for every snag has been overcome, and there will be no revolu-

be obtained in a finished condition from any radio store. It will be noticed that one terminal strip carries the aerial and earth terminals, and this can be screwed on at the one end of the baseboard. The other

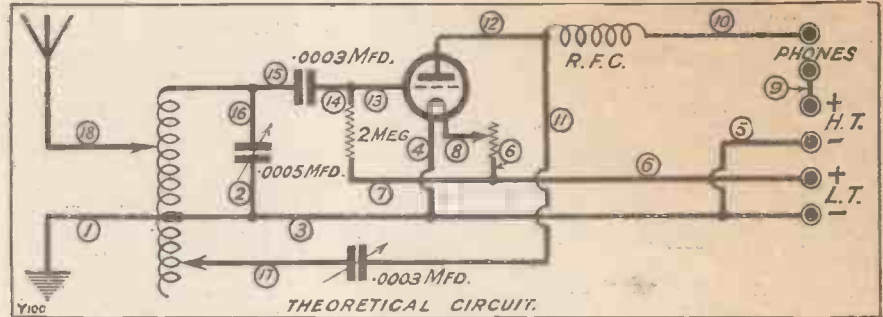

tionary rearrangements of components or wiring.

Using a Wooden Panel.

I enjoyed the work immensely, just as much, in fact, as I shall enjoy its description. And I am going to take you step by step, almost wire by wire, through every phase of it, placing myself in the position of the average constructor and endeavouring to the best of my ability to see the work, and any of its little difficulties, through his eyes.

First of all, the wood for the panel and baseboard must be obtained. You need have no fear that the use of wood instead of ebonite will result in a loss of efficiency, in fact, money spent on ebonite for this particular set would be so much waste, for it has been designed so that the cheaper material will prove equally suitable. But a good hard wood must be used, and mahogany is to be specially recommended. It should be $\frac{3}{4}$ -in. in thickness. Few "wood yards" stock anything else but soft woods, but if any difficulty is experienced in obtaining the material locally, Messrs. Hobbies, the fretwork people of Dereham, Norfolk, will supply it at a reasonable price on a postage-extra basis.

The wood should be obtained planed up and cut to size but not polished. The panel piece should be screwed to the baseboard with three or four $\frac{3}{4}$ -in. brass screws. To

strip must be drilled to take eight terminals although only four will be required for the one-valve set as described this week. If the set stays as a one-valver this strip can, of course, be cut down.

Now let us see what components will be needed. First of all, we require two variable condensers, one of 0.0003 mfd. capacity and another of 0.0005 mfd. maximum capacity. Both of these variables should be of the straight-line-frequency type, and should have some sort of geared movement enabling fine adjustments to be obtained.

The Components.

If cost is to be seriously considered, the 0.0003 mfd. can be of the straightforward direct-drive type, but, as we will be aiming at a fair degree of selectivity, the 0.0005 mfd. really must have a vernier control.

The variables can be of any good make. The H.F. choko must be an efficient choke, for a great deal of the efficiency of the receiver will depend upon this component. I used a Climax, but there are many reliable makes to choose from as you will see by referring to the advertisement pages. The variable filament resistor should have a maximum resistance of at least 15 ohms if it is to be of any great value, and the valve holder should be of the anti-microphonic type. The grid leak and grid condenser are straightforward items, as are also the baseboard-mounting single-coil holders.

A little trouble may be experienced in mounting the variable condensers owing to the thickness of the panel. It may be necessary to cut away a little of the wood in order to "countersink" the mounting nut or nuts. Two terminals should be mounted on the panel as shown in the panel diagram. These are the 'phone terminals.

The Space to Leave.

Brass screws of $\frac{3}{4}$ -in. will be found to be extremely useful for mounting the other components, and it will be advisable to get a good stock of these in. It will be noticed that the baseboard-mounted components form a group approximately in the middle of the baseboard. Get them fairly close together. I am not giving baseboard measurements, for doubtless in some cases there will be deviations from the makes of components I used. But the photographs will at least show you how much space should be left clear in order to allow room for the additional stages, and you will also obtain a clear idea as to the disposition of the components. You will not go far

(Continued on next page.)

The PROGRESSIVE ONE.

(Continued from previous page.)

wrong if you arrange so that there is a clear 5 inches clearance between the filament resistor and the one end and 6½ inches between the H.F. choke and the other end.

Screw everything down tightly and moved again, for nothing will have to be moved again. Now let us leave this part of the work for a while and deal with the coils, for it will be these which will govern, to a certain extent, the actual wiring of the receiver; that is it will be necessary to have a coil in position during the wiring to ensure that the leads keep well clear of this accessory.

formed. A further 20 turns then follows; at this point a small hole should be pierced in the former and a long loop carried through. The end of this loop can be bared and connected to the socket of the coil holder (see diagram). The winding is then continued for another 10 turns and another small tapping loop made.

On again for ten turns, one more tapping loop, and finally a last 10 turns and the coil can be finished off by passing the wire through two small holes. This end should be made into a tapping loop by twisting up the wire similarly to the other loops. We now have a coil consisting of 90 complete and continuous turns of wire provided with tapping loops at its 20th, 40th, 60th, 70th, 80th, and 90th turns. The bottom of the winding and the 60th turn are connected to the coil-holder plug base.

The Daventry coil (if such is required) will be very similar, except that it should consist of 320 turns of 32-gauge wire. The "bottom" end of its winding will be connected to the coil-holder plug, it will have tapping loops at its 75th, 120th, 250th, 265th, 285th and 300th turns, and the 250th turn will be connected to the socket of the coil holder. The wire on this 5 X X coil can be wound in small bunches to get it on the reasonably small former.

'Patent Wiring Scheme.'

Now we can plug one of the coils in, and also a valve, and commence the task of wiring. I am not going to let any one of you go wrong in this most important part of the work, and I want you to read the following few paragraphs closely and study the diagrams carefully.

I have not yet said much about the circuit employed in this one-valve stage because I wanted to discuss this while detailing the wiring. You see, I have polished up my patent wiring scheme in such a way that I am hoping that it is going to make it not only easier for you to wire up the set, but also easier for you to understand how to read a theoretical diagram. It is not essential that you should be able to do this before you build a set, but, at the same time, it is very useful to have the ability to interpret theoreticals, and it makes radio work much more interesting.

The circuit I have employed is a straightforward detector circuit introducing the

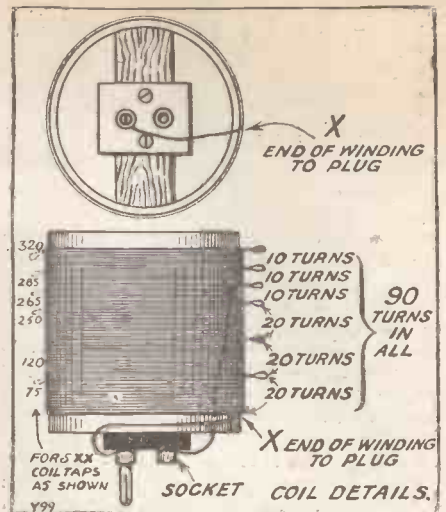

so-called Reinartz method of reaction. As you will see by the theoretical diagram (if you cannot see, hold on a minute!), a coil is so arranged that it enables the aerial to be "tapped" at any one of several points in order to provide a varying degree of selectivity. Part of this coil is used as a reaction coil, the control of regeneration being carried out by a 0003 mid. variable condenser.

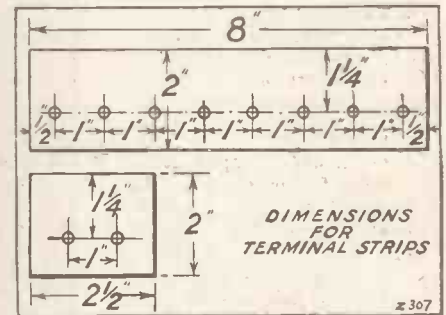

Now you will notice that this theoretical diagram is covered with numbers, ranging from 1 to 18, you will also see that the wiring diagram bears a similar series of numbers. Further, you will notice that the point-to-point checking list has numbers inserted here and there. All these numbers are
(Continued on next page.)

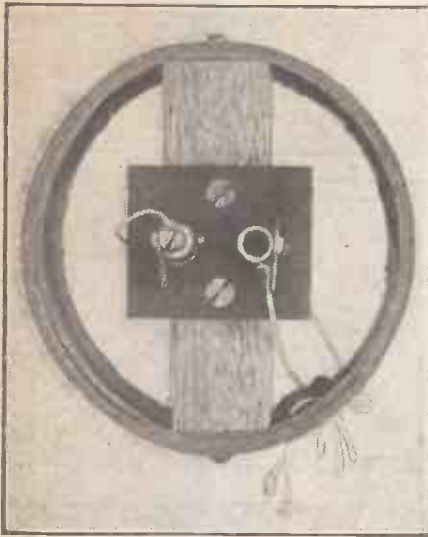

A photograph of the base of the coil, showing its simple construction.

Two coils will be required, one to cover the normal broadcast band of wave-lengths, and the other to cater for Daventry, and such stations. For the first, two ounces of 26-gauge D.C.C. wire will have to be obtained. The former consists of a 3¼-in. length of 3-in. diameter tubing. This tubing can be of "Pirtoid" (Clarke Bros.), ebonite, or even cardboard, providing it is fairly substantial. I have included a special diagram of the coil and a "close-up" photograph of its base in order that you can see exactly how it is made.

Winding the Coils.

A piece of wood is screwed into one end of the former, and on this is fixed an ordinary single-coil holder of the baseboard-mounting type. This forms the plug of the coil, and the end at which this is mounted I shall style the "bottom" of the coil. The winding should be commenced at this end. Two or three small holes should be drilled in the former, ¼ in. or so from the end, and the wire threaded through, leaving an inch or two for connecting purposes. This end can, if desired, be connected right away to the plug of the coil holder fixed at the bottom of the former.

Twenty turns should then be wound on tightly and evenly, and at the 20th turn a loop should be made. This is a tapping point. The wire should not be broken, and the winding should be carried straight on for another 20 turns and then another loop

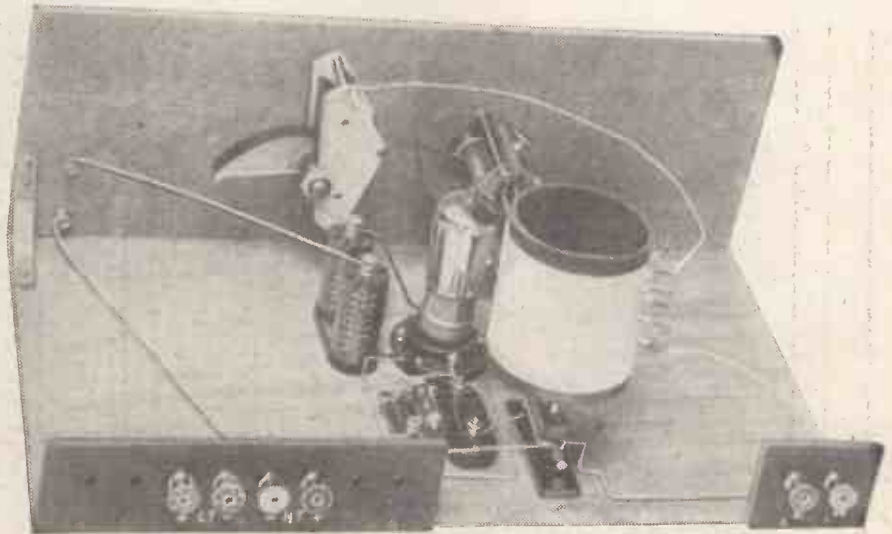

Here the valve and coil are shown in position. You must get this one-valve set working properly before you allow it to grow up to a two-valve.

The PROGRESSIVE ONE.

(Continued from previous page.)

related. In effect, 3 on the theoretical diagram corresponds with 3 on the wiring diagram, and 3 in the list of connections.

Now have you got the idea? If this does not enable you to dig out what those funny little symbols mean in the theoretical, then nothing will! Of course, you must allow just a little latitude in the interpretation, because the two diagrams are of different types. A long lead shown in the wiring diagram might look very short in a theoretical. However, it should not take you long to connect the two up together in such a manner that you will be able to gain as much from a theoretical diagram as from a wiring or a pictorial representation of a circuit.

But these numbers are going to be of even greater assistance to you in the construction of this particular set, and as the weeks

roll by and H.F. and L.F. stages are added you will more and more realise their value—at least that is my great hope!

Let us get on with the wiring. It does not matter very much what sort of wire you use for this, although I personally prefer square or round section 18-gauge tinned

copper. Soldering is advisable, but if you are not an adept at the art I would rather you dodged it wherever possible, because bad soldering makes for bad connections and all their subsequent troubles. Keep all the wiring down as low as possible, but well spaced and clear of the baseboard.

(Continued on page 680.)

WIRING INSTRUCTIONS.

Join Earth terminal to plug of coil holder (1) and thence to moving vanes of .0005 variable condenser (2) and also to H.T. — terminal or nearest wire which goes to it (3).

Join H.T. — terminal to one filament socket of valve holder (4) and to L.T. — terminal (5).

Join L.T. + terminal to one side of filament resistor (6) and to one side of grid leak (7).

Join remaining filament socket of valve holder to remaining terminal of filament resistor (8).

Join one 'phone terminal to H.T. + terminal (9).

Join other 'phone terminal to one side of R.F. choke (10).

Join other side of R.F. choke to one side of .0003 variable condenser (11) and to plate socket of valve holder (12).

Join grid socket of valve holder to one side of .0003 fixed condenser (13) and thence to remaining side of grid leak (14).

Join remaining side of .0003 fixed condenser to socket terminal of coil holder (15), and thence to fixed vanes of .0005 variable condenser (16).

Join a flexible wire to remaining side of .0003 variable condenser (17).

Join a flexible wire to aerial terminal (18).
Eighteen leads in all.

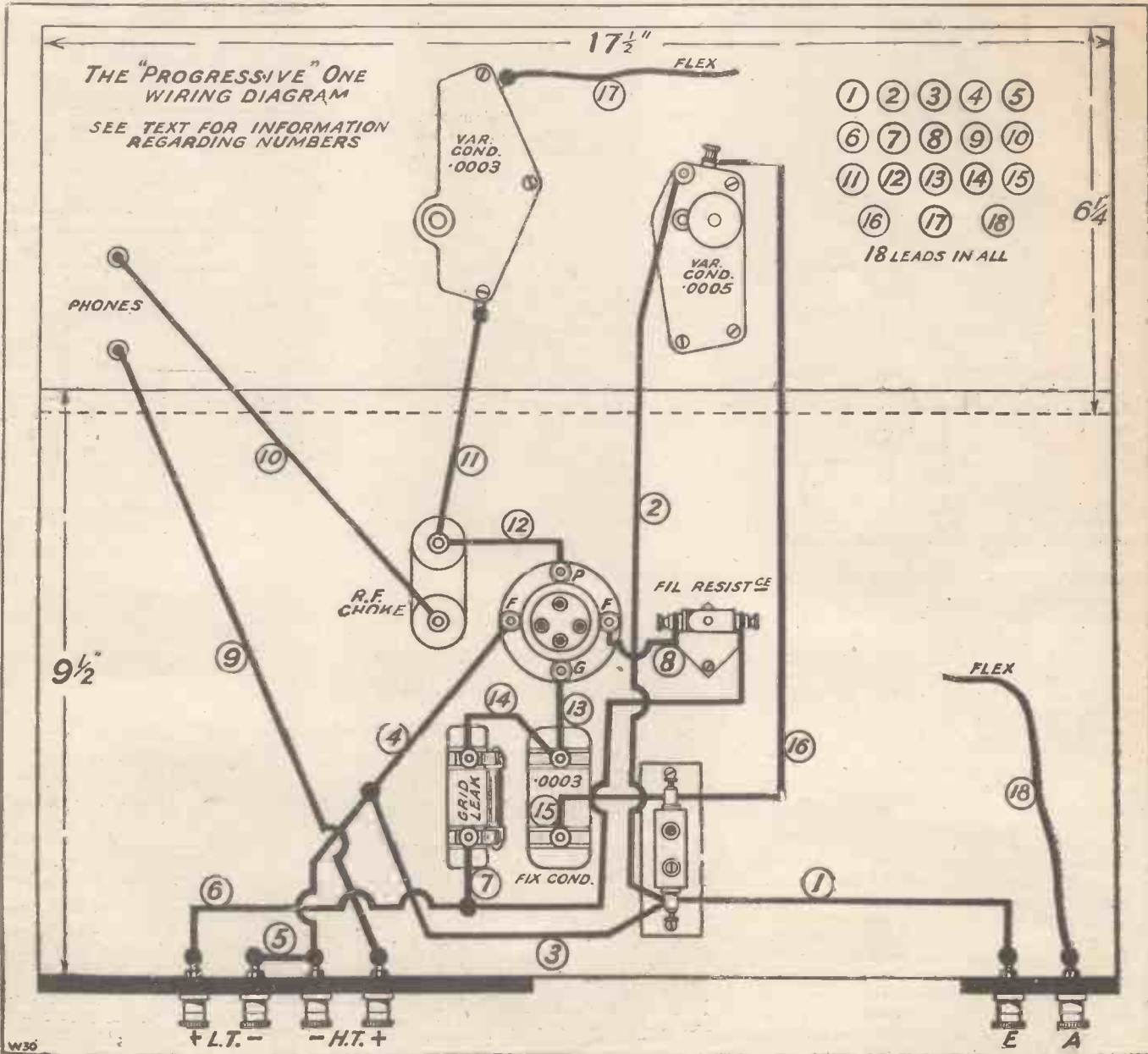



DISTORTIONLESS AMPLIFICATION?

"With certain reservations R.C. Coupling has entered upon a new lease of life as a remarkably efficient form of valve coupling," says the author of this article, and discusses the question of distortionless amplification in a way which will appeal to the practical amateur.

By J. ENGLISH.

RESISTANCE-CAPACITY coupling has occupied a prominent place in the design of amplifiers ever since the advent of the thermionic valve. In the early days, when long wave-lengths were the rule, it was even used extensively in H.F. amplifiers, but with the introduction and increasing use of short waves, R.C. coupling in H.F. stages was found to be useless. This was due to the disturbing effect at high radio-frequencies of valve and other stray capacities. As we shall see later, these capacities also play an important part in the design of R.C. coupled audio-frequency amplifiers.

However, R.C. coupling has never been entirely lost sight of as a valuable method of obtaining practically distortionless amplification. Like other things in wireless, it has had its vicissitudes, being temporarily forsaken at times for the greater attractions of transformer and choke coupling.

While the battle raged furiously over the respective merits of the latter, a few earnest

filament connections are not shown for sake of clearness.

We will suppose that the input of the first valve is connected to some form of detector in such a manner that L.F. voltage variations are applied to the grid. From first principles

Now if this resistance is free from self-capacity and has no self-inductance, the transformation of anode current into volts will be constant whatever the frequency of the input voltage. This means that distortionless amplification will be obtained, certain conditions of valve operation being satisfied.

The Anode Resistance.

The next step is to decide on the correct value of anode resistance, which we will call R . The limitation in the choice of R was the chief cause of the poor results given by the earlier methods, as we shall see later.

First of all the other part of the anode circuit, from anode to filament, has a resistance of its own. This internal valve resistance R_a must be added to the external resistance R , giving the combination of Fig. 2. This is really a potentiometer arrange-

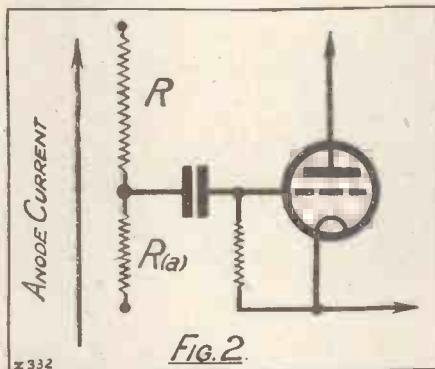

it follows that corresponding variations of anode current will be set up. In order to get any amplification at all we must insert in the anode circuit something which will turn these current variations into voltage variations. The latter will then be magnified versions of the original grid voltages. This change is essential because the grid of the next valve will respond only to voltage changes.

Whatever "something" we insert in the anode circuit, the ratio of volts produced to volts on the grid is the measure of the actual amplification obtained, so that the greatest voltage transformation is highly desirable.

The technical term for this "something" is an "impedance" which, in any coupling, may be a resistance or a combination of the three fundamentals, resistance, inductance and capacity, such as a transformer primary. In the system under discussion we shall use a resistance.

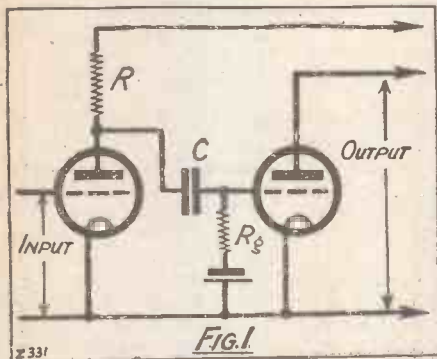
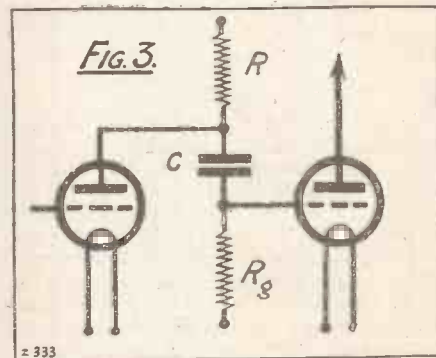

experimenters remained faithful to the R.C. method, hoping eventually to evolve the perfect amplifier.

Within the last year or so there have been developed new methods which offer great promise of entirely vindicating the hopes of these early enthusiasts. With certain reservations R.C. coupling has entered upon a new lease of life as a remarkably efficient form of valve coupling for L.F. and possibly H.F. amplification.

Early Methods.

Now the earlier methods suffered from several disadvantages, chief of which were low amplification, the necessity for high anode voltage, and unreliability.

In order to appreciate these disadvantages and the way in which they have been overcome by modern methods, let us examine briefly the electrical mechanism of R.C. couplings, the classical circuit being shown in Fig. 1. It is necessary to show two valves, as in any amplifier the output of one valve and the input of the next are one inseparable whole. Batteries and

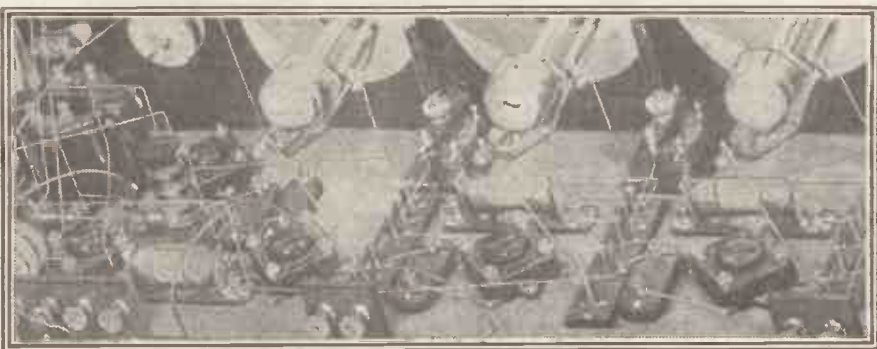

Practically every modern multi-valver incorporates at least one stage of R.C. coupling. This is the back of a five valver, and on the left will be seen the wire-wound anode resistance and other R.C. components.

DISTORTIONLESS AMPLIFICATION?

(Continued from previous page.)

of anode volts to grid volts, this ratio being the voltage factor (μ) of the valve. By calculation, it is found that very little advantage is gained by making R more than ten times R_a , the amplification then being 90 per cent of the full theoretical value.

$$\text{(Amplification)} = \frac{R}{R_a + R} \times \mu$$

Now let us see how this affected the earlier experimenters. The best valves available to them had an R_a never less than 25,000 ohms. As the voltage factor of these valves was about 6, the maximum amplification obtained would be some 51.

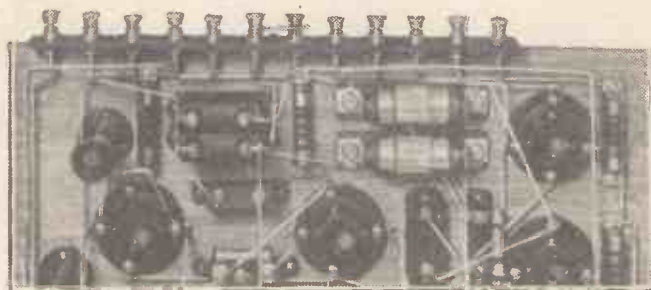

A receiver that is wired up on the lines of the circuit shown in Fig. 3.

But consider what happened when these experimenters tried to use an R of 250,000 ohms. The valves needed an average anode current of one milliampere with an anode voltage of some 50 volts for reasonably pure amplification. But one milliampere flowing through 250,000 ohms causes a drop of 250 volts, so that to get 50 volts on the anode they had to use a 300-volt H.T. battery!

This huge H.T. voltage was impracticable for general use, so that a smaller R had to be used with a corresponding loss of magnification. The anode resistances also gave rise to trouble as they were not constant, the passage of even such a small current as one milliampere causing disintegration and much noisiness. The introduction of wire-wound resistances, however, solved this difficulty.

The final step in amplification is to transfer the anode voltage variations to the grid of the next valve in the most efficient manner. We cannot connect the anode direct to the following grid, because the latter would then receive a high positive D.C. potential, paralysing the valve. In fact, the merest trace of positive bias on the grid of R.C. coupled valves is absolutely fatal to distortionless working. Therefore, we use a fixed condenser which insulates the grid from the high D.C. potential, but passes the L.F. voltage variations more or less readily according to its capacity.

The New System.

Since the grid is effectively insulated, it is necessary to use a grid leak, a resistance large enough to prevent serious leakage of L.F. voltage variations while preventing the accumulation on the grid of an excessive negative charge.

Negative bias can be communicated to the grid of this valve via the leak by means

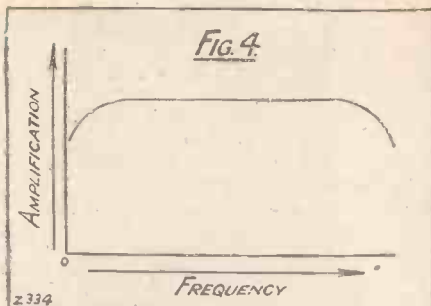

of a bias battery at the filament end, and as no grid current flows the grid voltage will be that of the bias battery. This is a point which some amateurs have difficulty in grasping.

Now the anode resistance, grid condenser and grid leak are all inter-related and for efficient amplification the value of each is a matter of great importance. We will leave this subject until later when dealing with the modern methods of R.C. coupling. The relative values of these components in either method are derived from the same principles.

Some time ago, two German scientists, Von Ardenne and Heinert, developed a new method of R.C. coupling. This consisted essentially in the employment of anode resistances of much higher value than formerly used, resistances of 2 megohms and more being specified. These investigators also showed the necessity for using valves having large voltage factors, and this led to the development of special valves having factors some five times greater than any previously known. Doubtless, some of you are aware of the strides recently made by our own valve manufacturers in the production of these special valves, and of the good results obtainable with them.

High Magnification.

Now the electrical mechanism of Von Ardenne and Heinert's amplifiers does not differ appreciably from that described above. The anode resistance changes current variations into voltage variations, which are passed to the grid of the next valve via a fixed condenser, the grid being stabilised by a leak resistance as before.

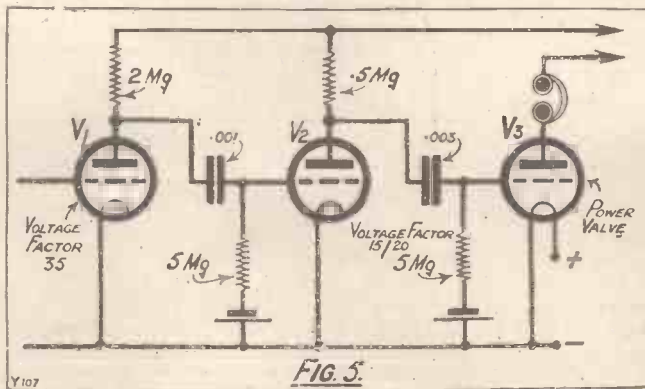

There is a difference in the new method in that the operating part of the valve characteristic is slightly curved instead of being straight. However, the effect of using a very high anode resistance is to make the resulting distortion of negligible importance.

Where the new method differs most from the old is in the results obtainable. With the special valves mentioned above, an amplification of some 15 to 20 per stage is possible, the output being remarkably free from distortion. Moreover, these amplifiers

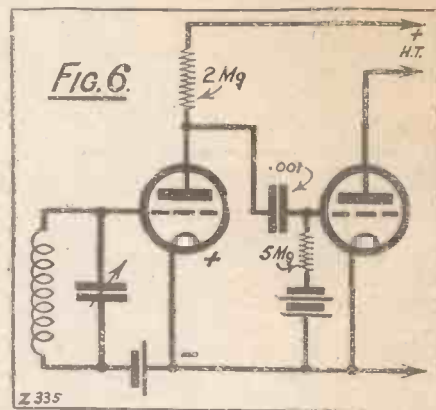

are entirely reliable, while the battery power required is less than normal. Thus the disadvantages under which the earlier experimenters laboured have been largely overcome.

For this new method to be of practical use to us, it is necessary to know the correct values of coupling components, the proper operation of valves, and the limitations of the method, if any.

Resistance Values.

Let us examine first of all the anode resistance R. As before, the larger we make this the greater the amplification per stage. But there is a limit to the value of this resistance. On the higher frequencies corresponding to the top notes of the piano, etc., the effect of valve and stray capacities will be similar to a resistance in parallel with R, thus lowering the effective resistance of the latter. Also the grid-leak resistance must always be greater than R, so that in general the anode resistance need not exceed 2 or, in some cases, 3 megohms.

The anode current flowing through these resistances is but a fraction of a milliampere, so that wire-wound resistances are not necessary for quiet working. A most satisfactory form of resistance is the metallised type of grid leak, in which the current path consists of a minute film of metal deposited on a glass thread. These resistances are cheap, and will carry all the anode current required without noise. For the utmost reliability the grid leaks should also be of the same type.

There now remain the coupling condenser and the grid leak to be considered. The value of each has a profound influence on both

(Continued on next page.)

DISTORTIONLESS AMPLIFICATION ?

(continued from previous page.)

quality and amplification. Taking the grid leak first, suppose that the coupling condenser, C, in Fig. 3, offers no resistance to the transfer of L.F. impulses to the next grid. In Fig. 3 we have another potentiometer arrangement similar to Fig. 2. This time we want to get the maximum voltage drop across R_g so that it is obvious the latter must be large compared with R. As in the case of the latter, the limiting factor is again the shunt resistance of valve and other stray capacities. In general, it is found that no benefit accrues from making R_g greater than 5 megohms.

Coupling Condensers.

Now we come to the grid-coupling condenser, which is theoretically the weakest link in the chain. The resistances R, R_g

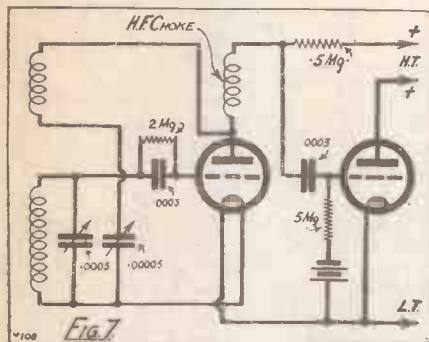

are independent of frequency, so that we should obtain perfectly even and distortionless amplification of all notes from bass to treble if the grid condenser were also independent of frequency. Actually, it passes a percentage of the L.F. impulses applied to it varying with the frequency of the latter, a falling off occurring on the lowest notes. If we made this condenser very large, say 2 mfd., it would be almost independent of frequency for all practical purposes, but amplification would not be distortionless. The grid of the next valve would tend to choke up unless a much smaller grid leak were used, when amplification would suffer seriously. This demonstrates another important relation between the grid condenser and leak.

Loss of Bass Notes.

From theoretical considerations it is found that the correct capacity of the grid condenser decreases with an increase in both R and R_g . If R and R_g are increased to large values, as in the new method of R.C. coupling, quite a small grid condenser will ensure almost even amplification over a large range of frequencies.

The question of grid-condenser capacity is not so vital in practice as theory would lead us to suppose, for even the better class loud speakers reproduce bass notes very badly. It requires an ultra-modern loud speaker, such as the Rice-Kellogg, or other moving coil types, to show up any deficiency in the amplification of the lowest frequencies.

With a good cone loud speaker no appreciable loss of volume of the lower notes of the piano is noticeable when using less than the calculated capacity. When anode resistances of .5 to 2 megohms and grid leaks of 2 to 5 megohms are used, a fixed condenser of .001 mfd. is a good all-round value, any increase in capacity over this value effecting no noticeable improvement.

An extremely important point about the coupling condenser is that its insulation resistance must be of the very highest order obtainable. Even a leak of a few megohms will upset the amplifier. Well-known brands of mica dielectric, however, are quite satisfactory in this respect.

So far we have only dealt with one stage of R.C. coupling. With more than this further problems arise, stray capacities and the impedance of the coupling condensers having a more noticeable effect. The valve capacities cause a drop in the amplification of high frequencies while the coupling condensers weaken the lower, so that the amplification curve of a three-valve R.C. amplifier appears somewhat like Fig. 4.

This fact has led to the development in Germany of multiple valves in which the coupling resistances and condensers together with the electrodes of as many as three valves are assembled in one glass-bulb. These marvels of manufacturing skill are much less susceptible to capacity effects as all the wiring is inside the "valve" itself. Merely by connecting suitable batteries the multiple valve becomes a complete three-stage R.C. amplifier giving an average amplification of nearly 1,000. Similar valves are said to be successful as H.F. amplifiers.

Problem of Overloading.

Although the new R.C. amplifiers are so efficient and free from distortion under proper conditions, the method suffers from one disadvantage. By reason of the high anode resistance the working characteristic is rather small, the portion available for distortionless amplification being usually between zero and 3 volts negative. In the first stage this is no disadvantage because the input is not likely to produce a grid swing greater than 2 volts. Owing to the high amplification, however, the input to the next stage will be some twenty times larger, so that if the incoming signals are strong, distortion is bound to occur. With a large input to the first stage it is better to use a combination similar to Fig. 5.

For the amplification of weak signals, a full three-stage amplifier can be used resulting in very high magnification.

Where the new method of R.C. coupling does score is in the coupling of a detector valve to a first stage L.F. amplifier, and in such a position it is good. In the future there is every reason to believe that R.C. coupling will become standardised where distortionless amplification is desired. Besides being capable of giving better results than either transformer or choke coupling, R.C. coupling is decidedly cheaper, while requiring considerably less battery power and taking up less space.

In the detector stage the R.C. coupled valve is not so limited to a small L.F. input as in the L.F. stage.

The best circuit to use for a non-regenerative detector is one similar to Fig. 6, anode bend rectification giving the purest signals

with sharp tuning. This is also the best detector to use if preceded by H.F. amplification for D X work.

For a regenerative detector it is necessary to use a lower anode resistance to get sufficient reaction. This would entail a loss of amplification but for the fact that the "leaky grid" method of detection, by making the grid positive, reduces also the internal valve resistance, thus partially restoring the ratio of R and R_a .

Suitable Two-Valver.

A representative circuit is shown in Fig. 7, this being ideal for a plain detector followed by L.F. stages, as reaction control is remarkably free from "backlash," making the receiver very sensitive.

Notice that in the valve following an R.C. coupling, negative grid bias is highly important and essential. If the grid of the next valve becomes at all positive the flow of grid current causes distortion in the second valve, while the effective resistance of the grid leak is so much lowered that the amplification of the first valve is greatly reduced.

In conclusion, it will be evident that recent developments in the technique of

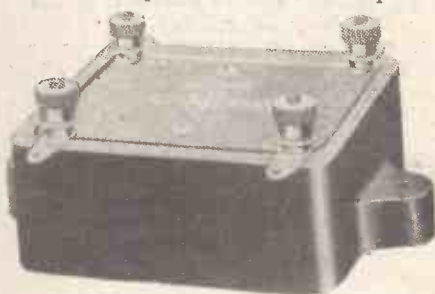

A complete R.C. coupling unit which embodies the grid condenser and grid resistance, and the anode resistance.

R.C. coupling have placed in our hands a very economical and simple method of low-frequency amplification providing at the same time the desirable qualities of high magnification with great freedom from distortion.

A DIAL INDICATOR.

By H. J. B. C.

As each station is tuned in on a set it is advisable to log the condenser readings and keep these logs by for future reference, so that when a particular station is desired it is necessary merely to re-set the condenser dials to their correct values. With movable dials some form of dial indicator or pointer should be incorporated on the panel, in order to allow accurate condenser readings to be made.

It is only necessary to make a cut or incision on the panel with a sharp penknife blade or scriber just above the condenser dial and in a vertical line with the condenser shaft centre. This line, say a 1/4-in. in length, can be finished off at the top by inserting the end of a small drill at the top end of the line and with one or two turns of the drill make what really mounts to an enlarged centre-punch mark. Now fill up both this and the line with white paint and a neat indicator will be the result.

TECHNICAL NOTES

By Dr. J. H. T. ROBERTS, F.Inst.P.

H.F. AMPLIFIER CONTROL.

VALVE LIFE—REMOTE CONTROL—A USEFUL TRANSFORMER

H.F. Amplifier Control.

ONE of the main difficulties with high-frequency amplifiers is to control the oscillation. All kinds of more or less intricate methods have been suggested and used, ranging from delicate balancing and neutralising systems to the use of non-inductive resistances in the grid-return leads and the well-known potentiometer stabiliser, as well as variable plate voltage.

Some of these methods, however, are beyond the ability of the ordinary set user or are very inefficient.

One of the simplest and most effective methods of controlling oscillation in high-frequency circuits is to use, in series across the grid and plate of the high-frequency valve, a very small variable condenser and a variable high-resistance with a range from practically zero to several megohms, and with a fairly fine adjustment.

A suitable arrangement includes a .00025 mfd. mica condenser, together with the proper resistance as mentioned above, wired in series and connected to the grid and plate terminals of the valve. The high resistance should be mounted alongside the valve, together with the condenser, so as to keep the H.F. wiring as short as possible, and the resistance should be so arranged that several turns of the knob are required to cover a range of, say, 500 ohms to 5 megohms.

Anode Resistance.

Whilst on the subject of valves, I should remark that it is always a good plan to use a variable filament resistance with a valve which has a high ohmic resistance in its anode circuit. The full emission from the filament will usually not be required, and it will be found that better results will often be obtained with the filament current reduced a little, apart from the obvious advantage that the L.T. battery is conserved.

Valve Life.

The life of a valve is shortened by excessive anode current. In many cases it is advantageous to use a high anode voltage, perhaps higher than that which is specified for the valve in question. The ill-effects of using this high voltage may, however, be neutralised by employing negative grid bias greater than that specified for the valve.

In other words, if you wish to increase the applied H.T. voltage for any reason, increase the negative bias to such an extent that the actual anode current remains about the same value as it would have been if the specified H.T. voltage and grid bias had been used. In this way the advantages of the higher H.T. voltage may be obtained without the danger of shortening the life of the valve unduly.

Invisible Radiation.

Reverting to the subject of television, I would like to say something about a point on which a number of readers have written

to me. This is the question as to whether it is possible for some creatures to see in the dark. It is popularly supposed that night-prowling animals, such as cats, are able to see in absolute darkness, and it has been suggested either that they see by rays emitted from their own eyes and reflected to them from the prey, or that they are able to perceive the heat radiations from their prey. It has been ascertained, however, that although a cat (for example) can certainly see very much better in nearly complete darkness than a human being (owing to the ability to open the pupils of the eyes very wide) the cat cannot see in a *totally* dark room.

The so-called "seeing in the dark," which has recently been demonstrated, is done by illuminating the object to be



An interesting receiver made up from Blue Print No. 20 by one of our Kentish readers. A glass panel has been employed.

viewed by means of rays which are outside the human visual range and then subsequently converting the reflected radiation into visible light.

Remote Control.

If you are sitting at the opposite corner of the room from a wireless receiver, and you wish to switch on the receiver without taking the trouble of going over to it, you may do so by the use of any of the various systems of so-called "remote control" which are now available. The newest addition to the simpler remote control devices is due to the Runbaken Company, and consists of a little ratchet-operated switching arrangement, contained in a case, and connected by means of a length of fine rubber tubing with a rubber bulb, the whole device being similar to that which is commonly used for operating the shutter of a photographic camera. With this arrangement you may leave the fine rubber tube trailing on the floor or you may run the same inconspicuously along a wall. You have thus only to press the rubber bulb and the little ratchet arrangement is actuated; this has the effect of switching on the set. A further depression of the bulb switches off the set, whilst a still further depression switches it on again,

and so on. So if a "talk" suddenly presents itself from the loud speaker, you are at any rate, spared the necessity for any great exertion; you merely give the rubber bulb a savage pinch, and that's that!

A Useful Transformer.

A very interesting transformer which was shown at the Exhibition is the "multi-former," by G. E. Pohn. This may be adapted to serve either as an output or intermediate transformer, or as a variable ratio low-frequency transformer. It may also be used as a resistance-capacity coupling unit, as a choke-coupling unit, or as a smoothing choke or choke-output unit.

All this is accomplished by using a laminated stalloy core with the centre section removable. Interchangeable windings, contained in moulded cases of uniform size, slip over this centre section and connect with spring contacts when they are in position. The resistance units have non-inductive windings.

Dry Plate Rectifier.

In view of the rapid development of the dry rectifier, it is interesting to note that a British patent has just been issued to

Samuel Ruben, of New York City, U.S.A., in connection with the rectifier which employs symmetric pairs or couples of the dry surface-contact variety. Samuel Ruben was, if I remember rightly, the originator of the dry rectifier, or, at any rate, he was one of the earliest investigators to produce a practical working device. His original device suffered from the fact that the action depended wholly or partly upon some obscure electrolytic effect which was influenced by atmospheric moisture. I understand that in his latest device this defect is entirely ruled out.

The electrode elements, which are referred to as electro-positive and electro-negative, when pressed together have opposite current-impeding or film-forming properties. One of the electrode elements is made of a metal of the chromium group, the other electrode element consisting of metallic oxide. To enable the rectifying device to operate satisfactorily in intermittent service it has been found that the electrode elements must be kept in contact under a pressure sufficient to overcome the electrostatic repulsion of the conducting surfaces. A suitable pressure is about one ton to the square inch, whilst the current density must not be more than about half an ampere per square inch. The pressure, of course, is obtained in a very simple way by the use of a screw bolt which passes through central holes in the various elements; in this way the whole series of elements may be firmly bolted together.

Clips.

Spring clips are very useful to the wireless experimenter, not only for making quick connection to battery terminals

(Continued on page 684.)



BE A RADIO MISER

THE IMPULSES your aerial receives from foreign stations are doubly precious because of their weakness. You must arrange your receiver so that none of the energy is lost. You must guard against leakage. You must be miserly in the way you save each minute portion. This means more than using good radio parts—it means using the one make of parts that have been conspicuously notable for their low loss qualities for many years—LISSEN.

ECONOMISES H.T.

By putting a Lissen 2 mfd. Mansbridge Condenser across your H.T. Battery (1 mfd. will do, but larger size is better) you will lengthen its life by 10 per cent.



LISSEN Mansbridge Type Condensers

2 mfd. 3/6	1 mfd. 2/6
Other capacities:	
'01 1/9	'25 2/-
'05 1/9	'1 1/9
'025 1/9	'5 2/3

A specially moulded solid insulating case totally encloses each Lissen Mansbridge Type Condenser.

NEVER LEAK OR VARY

Lissen fixed condensers are accurate to within 5 per cent. of their marked capacities. They never leak, they never vary. Less than a year ago they were being sold at twice the price—and since then they have been still further improved. You can't buy a finer condenser



LISSEN Fixed Mica Condensers

'0001 to '001, 1/- each (much reduced)
'002 to '006, 1/6 " " "
A pair of clips is included free with every grid condenser.

NOW COSTS 1/- LESS

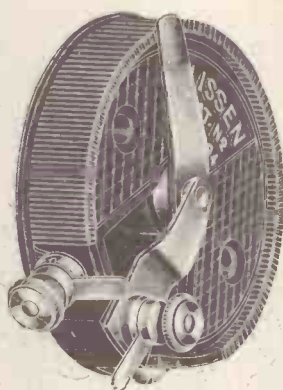

The baseboard type of Lissen Resistor is now reduced from 2/6 to 1/6. This type has, of course, no knob, dial or pointer, but is provided with 2 holes for screwing to baseboard. 7 ohms Rheostats: 400 ohms Potentiometer, previously 2/6, NOW 1/6

ALSO REDUCED

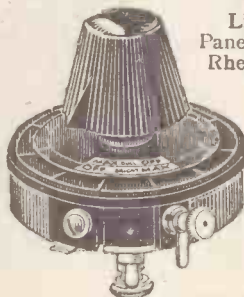

Lissen Panel Type Rheostats

The wires do not loosen, the arm keeps in perfect contact—nothing ever goes wrong.

Rheostats 7 and 35 ohms .. NOW 2/6 (Previously 4/-)
Potentiometer 400 ohms 2/6 (Previously 4/8)
Dual Rheostat 35 ohms 4/6 (Previously 8/-)

SAVE CURRENT

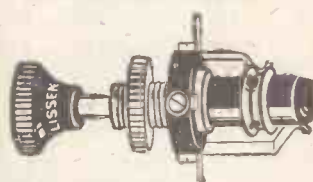

Energy is often lost at the switch points. These Lissen SWITCHES are designed to prevent energy leaking away while they do their work efficiently. There is one for every switching need—each one is very neat.

- Now
LISSEN TWO-WAY SWITCH 1/6 (Previously 2/9)
LISSEN KEY SWITCH 1/6 (Previously 2/6)
LISSEN REVERSING SWITCH 2/6 (Previously 4/-)
LISSEN SERIES PARALLEL SWITCH 2/6 (Previously 3/9)
LISSEN FIVE-POINT SWITCH 2/6 (Previously 4/-)
LISSEN D.P.D.T. SWITCH .. 2/6 (Previously 4/-)

STRONGER SIGNALS



There is not a square inch of superfluous ebonite in this Lissen Valve Holder. That means low capacity, and therefore stronger, clearer signals. Shown ready for baseboard mounting, but can also be used for panel mounting by bending springs straight. Patented. Previously 1/8. NOW 1/-.

ABSOLUTELY SILENT



Lissen Leaks are absolutely silent in use; their resistances never alter. This was proved some time ago by exposing them to the rain and sun on our factory roof. All resistances, Previously 1/8. NOW 1/-.

WHENEVER RADIO PARTS ARE WANTED USE LISSEN
LISSEN LIMITED, 8-16, FRIARS LANE, RICHMOND, SURREY.

Managing Director: THOMAS N. COLE.

If you prefer
 a cork-tipped cigarette
 say

Player's
 cork tipped
 please

10 for 6^{D.}

20 for 11¹/₂^{D.}

50 for 2/5 100 for 4/8



REGISTERED TRADE MARK No. 154,011.

TIPPED WITH CORK OF PURE NATURAL GROWTH

How to take out a RADIO PATENT

Some Valuable Advice to the Home Constructor and Amateur Inventor.

By A PATENT EXPERT.

INVENTIONS of commercial value may be divided into two classes. The first and probably the rarer kind is born of a sudden inspiration. It comes in a flash, sometimes when one is pottering about at the work-bench, and sometimes as the outcome of a placid day-dream.

The other kind is the hard-won reward of concentrated thought and laborious experiment steadily directed towards a definite objective.

In the long list of wireless inventions one finds examples of both classes. The highly technical subjects of beam telegraphy, multiplex signalling, and wired-wireless working belong essentially to the realm of costly experiment and laboratory research.

On the other hand, there are innumerable gadgets and contrivances associated with crystal and valve reception which owe their origin to the fertile brain of the enthusiastic amateur. And, it may be added, there is plenty of room and a good market for as many more, provided they are such as either create a new demand or supply an existing need.

As a side issue, one also finds curious receiving circuits of a type which will not bear systematic analysis, although they claim to give extraordinary results. These seem to be merely the outcome of a happy-go-lucky assembly of component parts in which the "lucky" factor happens to predominate.

The Stamp Fees.

The amateur who thinks he has got a good "notion" will be well advised to protect himself by taking out a patent.

It is necessary to do this, because there is no common-law right to an abstract "idea." Once the idea is published or communicated to other people, it becomes the property of anyone who likes to use it.

On the face of it, this is unjust, and accordingly the law provides special machinery for giving legal protection to literary, artistic, and inventive ideas provided certain conditions are fulfilled.

In the case of inventive ideas this legal machinery is vested in the Patent Office, and the essential conditions to be fulfilled are set out below.

In the first place there are certain fees to be paid. These are necessary to defray the cost of maintaining the Patent Office, and represent the price to be paid for

regularising the legal position of the inventor.

The full cost in stamp fees for obtaining Letters Patent is £5. For this sum protection is given for four years from the date of the grant. After the first four years an annual renewal fee must be paid, which increases from £5 for the fifth year to £16 for the sixteenth and last year of the patent's life.

Renewal Costs.

The renewal fees may seem unduly heavy. In most cases, however, they need not be further considered by the amateur inventor. He will either have sold or abandoned his patent by the end of the fourth year; or, if not, he will be making so much money out of it that the cost of keeping it alive will be a relatively small item.

If the first cost of £5 seems too heavy, this need not be paid down at once. An inventor may get what is called provisional protection by merely paying £1.

At any time within nine months of this first payment he may file what is called the complete specification, this costing a further £3. When the complete or final application has been examined and passed by the Patent Office, he will be called upon to pay a Sealing fee of £1, thus making £5 in all. His patent will then cost nothing further until the first renewal fee falls due, four years later.

So much for stamp fees. A second and equally important condition to be fulfilled by the would-be patentee is to file at the Patent Office a full description of his invention.

This description must be complete and above-board. It must, in fact, be sufficiently explicit to enable the general public to make use of the invention when the monopoly granted to the original patentee has expired.

If any essential part of the invention is omitted from the description as supplied to the Patent Office, this omission may result in rendering the patent grant invalid and of no effect, should the holder ever try to enforce it in a court of law.

Full Description Required.

The reason why this condition is so stringent is this: A patent is only granted to an inventor on the understanding that after he has had a monopoly for so many years the general public shall thereafter



be entitled to have the free benefit and use of the invention.

After all, it is the State (which is another name for the general public) which grants the monopoly to the inventor and, through the medium of the Patent Office, invests his "idea" with the legal rights and privileges of a form of personal property. It follows that the inventor owes a duty in return to the public, i.e. that of giving a full and fair description of his invention.

In other words, he must put the public in the position of being able to take free advantage of his contribution to general progress, after his own privileged monopoly period has come to an end. If he fails to do so, he strikes at the root of the implied contract on which the patent grant rests, and in such an event the law will naturally hold that the contract is void.

This full and complete disclosure of the invention, it should be added, need only be supplied in the complete specification.

Drafting the Specification.

When a patentee applies for provisional protection, he need only describe the general nature of his invention, although he must give sufficient detail to enable the broad idea of the invention to be identified with the complete description when this is subsequently filed.

It must, however, be clearly understood that the filing of a provisional specification gives no legal rights to the applicant, beyond establishing a priority of date. If he does not proceed to file a complete specification in due course, the application is held to be abandoned, and the matter is at an end.

A certain amount of skill is naturally called for in preparing or drafting a patent specification. If the invention is of a comparatively simple nature, it is usually possible for the inventor to set it out in proper form without the help of professional assistance.

If, however, the invention is of a complicated nature, or capable of wide application, he would be well advised to seek the aid of a chartered patent agent, so that he may not lose the full benefits to which he is entitled, owing to a technical or legal defect in the drafting of his specification and claims.

BROADCAST NOTES.

FROM OUR BROADCASTING CORRESPONDENTS.

Falkland and Palestine—A Hungarian Conductor—Why Act Shakespeare?
Modern Life in Japan—Wedding March for Sixpence—Newcastle's New Bishop.

Falkland and Palestine.

SOME of the big things that happened during the war followed so closely on each other that, except by those who saw or took part in them, they are remembered to-day only as mere incidents. Even to us who remember clearly those four years, there is much to be told of stories, well known by name or in outline, though not in that intimate detail which alone can reveal the heroism of our kinsmen, our friends and our enemies alike, and bring us face to face with the horror of the war—that blot on civilisation which the whole world will, sooner or later, decide to obliterate once and for all time.

The forthcoming programmes from London contain two important talks which should assist to fill the gap. One is to be given at 9.15 p.m. on Monday, December 5th, by Paymaster Commander Gordon Franklin, R.N., who will describe his experiences in the Battle of the Falkland Islands, the anniversary of which falls on December 8th. Commander Franklin was on board H.M.S. "Invincible" during the engagement, the battle-cruiser which, with H.M.S. "Inflexible," was sent out secretly from England to annihilate the German squadron under Admiral Von Spee after he had wiped out an inferior British force at Coronel.

Commander Franklin, who is now the editor of the "Empire Record," the monthly magazine of the British Empire Union, had unique opportunities of providing a vivid eye-witness account of the most decisive sea engagement in which our war vessels participated, and his subject contains all the elements for a fascinating talk.

The other talk, somewhat different in character, inasmuch as it will be given by a bishop and not by a fighting man, is in connection with the tenth anniversary of Lord Allenby's entry into Jerusalem. The Right Rev. Bishop MacInnes has spent over thirty years in the Near East, in the course of which he has travelled all over Palestine and Egypt, and his work naturally brought him in close touch with our troops. No one has had greater opportunities for observing the effects and changes in the Holy Land which the British occupation has brought about, and his talk at 7 p.m. on Tuesday, December 6th, will deal largely with the progress made during the last ten years.

A Hungarian Conductor.

The eminent Hungarian composer, Kodaly, is to conduct a performance of his "Psalmus Hungaricus" in the course of a light orchestral and choral concert which will be given under the direction of Mr. Stanford Robinson by London, Daventry and other stations on Sunday, December 4th. The programme will include both vocal and instrumental excerpts from popular classics. The soloist will be Hans Buttermund, principal cellist in the Berlin

Philharmonic Orchestra, which at that time is to give some performances under its conductor, Dr. Furtwengler.

Why Act Shakespeare?

Mr. William Shakespeare, a distinguished singing master of the Victorian era, will, it is hoped, preside at the first of a series of six debates arranged by the B.B.C. in conjunction with the King Edward's Hospital Fund for London, to take place in the

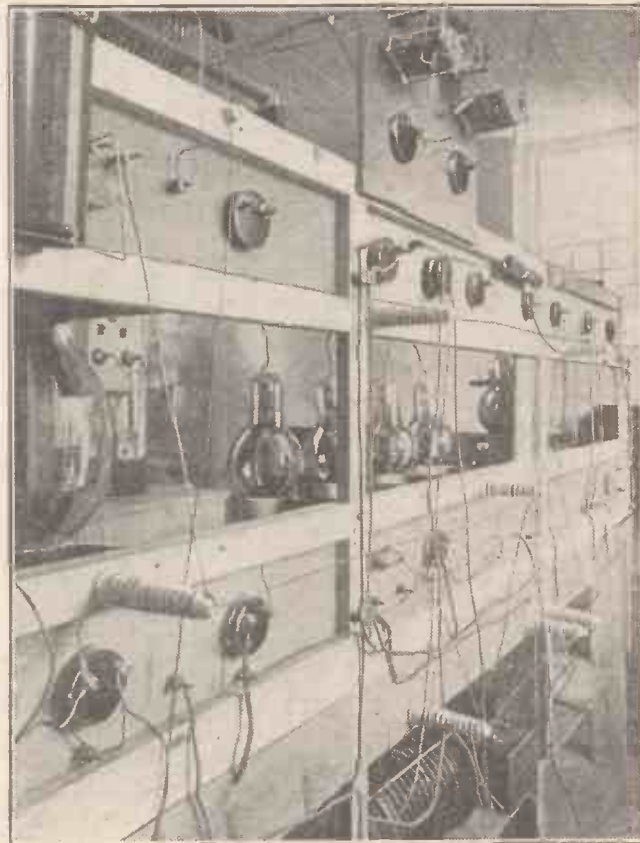

The back of the main transmitting panel at 2 N M, Mr. Gerald Marcuse's famous amateur station.

Central Hall, Westminster, on Wednesday evening, December 7th.

The subject to be discussed is "Why Act Shakespeare?" Rebecca West, the well-known book reviewer, essayist, and author of the novels "The Return of the Soldier" and "The Judge," and Ben Greet, famous as the head of the Ben Greet Repertory Players, and an authority on the playing of Shakespeare, are the "contestants."

Arrangements are in hand to get in touch with as many other people as possible who can boast the name of Shakespeare, and invite them to be present. In addition to being broadcast, the whole of the series of debates will be open to the public, the pro-

ceeds going to the King Edward's Hospital Fund for London.

Modern Life in Japan.

Every year, in the month of November, the Emperor of Japan sets a subject for the Japanese New Year Poetry Contests. Then things really do begin to happen, and by the end of the year twenty thousand or more poems are submitted to the adjudicators, from which fifteen or twenty are selected and read to the Emperor and Empress on the Japanese New Year's Day, together with poems by the Emperor and Empress and other members of the Royal family, which, of course, are read first.

Dr. Neville Whyment, who up till August 1925 was a Professor under the Japanese Board of Education, translated many of these poems into English, as he has also done many other Chinese, Japanese, Mongolian and Polynesian works. This and other sides of his research work in the Far East will be dealt with in a talk, entitled "Modern Life in Japan," which Dr. Whyment is giving in the London Studio at 9.15 on Thursday evening, December 8th.

Wedding March for Sixpence.

Dr. A. Eaglefield Hull, one of the greatest authorities on music, three of whose series of four organ recitals at the Manchester Town Hall in December are to be broadcast, tells an amusing story of how he was once offered a fee of sixpence for playing the Wedding March. It was in the East End of London, where he was practising on a church organ, when the curate asked him if he would mind waiting for about twenty minutes as a wedding was to take place.

Dr. Hull saw the couple before the ceremony and told them he would play the same music as was played in all fashionable West End churches. Everything went well until the bridal couple were half the distance

down the aisle on their way out of the church. Then the bridegroom came back and, placing a sixpenny piece near the organ stops, smiled gratefully at Dr. Hull, and said "That's for you."

Newcastle's New Bishop.

Dr. H. E. Bilbrough, who was recently installed Bishop of Newcastle, is to preach in St. Nicholas' Cathedral on Sunday, December 8th, and the service is to be broadcast from the local station. This will be the first occasion on which Bishop Bilbrough has spoken before the microphone in his new surroundings, and this event should create great interest.



the latest receiver complete with battery compartments.

A competent receiver, tractable and ingeniously contrived; a beautifully executed cabinet with a snug chamber for the less pleasant-looking accessories. The Brandeset IIIB has precisely the same specification as the Brandeset IIIA, with the addition of battery compartments as shown in the illustration. The receiver is arranged for 1 detector and 2 L.F. valves, with simplified tuning control, and guaranteed for good loud-speaker reception from all English and the majority of Continental stations. Access to the roomy battery compartments situated immediately beneath the receiver is obtained by hinged doors, and the whole cabinet is executed in wax-polished fumed oak, with silver oxidised metal fittings. It allows for a beautifully compact, self-contained outfit, the only external arrangements being the wires for aerial and earth connection.

THE BRANDESET IIIB £8 : 5 : 0
(Royalty and Accessories extra)

the new Brandes Laminated Plate Accumulators

A new type of slow discharge accumulator which will hold its charge over long periods without sulphation, and is thus eminently suitable for the increasingly popular Dull Emitter Valve. It introduces the laminated plate which, besides retaining the charge for weeks, or even months, is proof against most of the abuses which rapidly destroy the ordinary plate. For instance, a Brandes R.B.10 can be fully charged in 8 hours as against the usual 2 days for ordinary slow discharge accumulators. With the stout girder-like construction of the plates, buckling is unknown, and even a direct short circuit does not harm them. The laminated plate feature is of the greatest possible value to slow discharge accumulators.

Accumulator R.B.10 (10 amp. hours actual) 5/6
Accumulator R.B.20 (20 amp. hours actual) 9/-
(Manufactured under Oldham Activation Process)

Send coupon below for full information on the complete Brandes range.

OTHER BRANDES PRODUCTS:

Brandeset IIIA	6	15	0
Ellipticon Cone Speaker	4	15	0
Table Cone	1	19	6
Brandola Loudspeaker	2	17	6
Table-Talker	1	10	0
L.F. Transformer (1:5)	0	15	6
L.F. Transformer (1:3)	0	15	0
Variable Condenser (.0005)	0	15	6
Variable Condenser (.0003)	0	15	0
Headphones	0	13	6

Brandes
RADIO PRODUCTS



Brandes Ltd.,
2/3, Norfolk St., Strand, W.C.2
Please send me your free illustrated catalogue.

Name

Address

.....

P.W.

Brandes products are only obtainable where you see this sign



Look at your face in the tea-pot

THERE you will see a reduced, distorted, and almost unrecognisable reproduction of your own features. A travesty of the truth—an insolence to the original.

You may have *heard* the same sort of thing in Radio. DO NOT BLAME RADIO—you might with equal justice blame your own face. Just as a good mirror can provide a truly realistic reproduction of your features so can good radio apparatus reproduce with fidelity the original studio performance. But it must be good radio apparatus, properly installed, properly maintained and, of course, there must be a good loud speaker.

The

AMPLION

is a

GOOD LOUD SPEAKER
25 models from 37/6

Announcement of Graham Amplion Limited, 25, Savile Row, London, W.1.

Components of Distinction & Quality

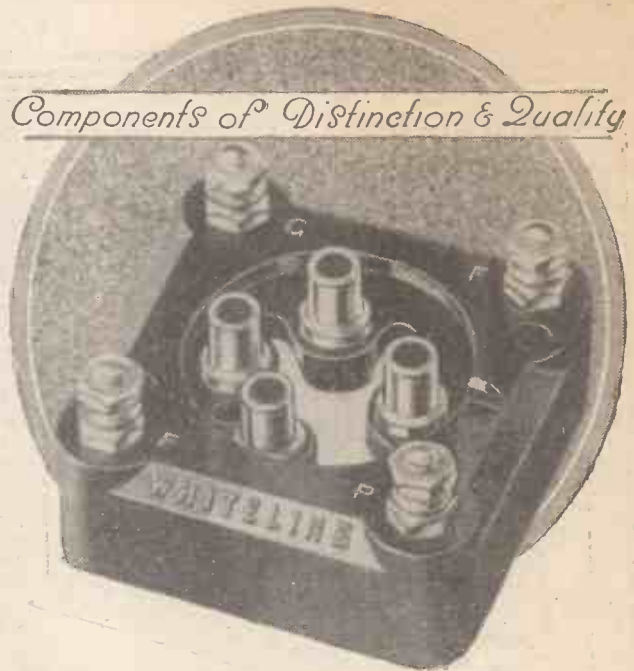

Whiteline Valve Holder

A great advance over all previous types of "Springy" valve holders. Inter-electrode capacity is reduced to a minimum and is constant. Thus the "Whiteline" holder is admirably suited for super-heterodyne and short-wave receivers. The springs are so designed that while the initial amplitude to any given shock is as large as required, the damping is quick and gentle. Made of genuine Bakelite and supplied with terminals, soldering tags and fixing screws. Overall dimensions of base, 1½ ins. square.



L.F. TRANSFORMERS
List 284. Ratio 3-1.
22/6.
List 285. Ratio 6-1.
25/-.
Also in Multi-ratio
giving 1-8, 3, 5-66.
4-5 and 6 to 1.
List 286. 27/6.
Also LOW FRE-
QUENCY CHOKE
List 287. 20/-.



UNIVERSAL
H.F. CHOKE.
List 288. 9/-

THE "WHITELINE" FOR SAFETY
LIST 282 2/3

Send 1½d. in stamps for the new Bowyer-Lowe Catalogue



BOWYER-LOWE CO., LTD., LETCHWORTH

A BOOK THAT EVERY EXPERIMENTER SHOULD HAVE.
"THE BOWYER-LOWE STANDARD 7- and 8-VALVE SUPER-
HETERODYNE." How to Build and Operate.
By A. R. BOWYER-LOWE. Price 2/-
Send your remittance for a copy to-day.



BRITISH BROADCASTING

THE other day I happened upon an old journalistic colleague who in recent years has become a successful stage artiste. He was telling me of the quite extraordinary change in the manner, method, and attitude of the B.B.C. Four years ago, he appeared frequently before the microphone. Then, more lucrative engagements elsewhere precluded him from continuing his microphone work.

And it is only now, after an interval of four years, that my friend finds himself able to take fresh broadcasting engagements. As he is a man of marked artistic attainments, wide experience and sound judgment, I was extremely interested and not a little alarmed at the account he gave me of the contrast in his experiences.



The control room at Birmingham. Mr. Cooper, the Engineer-in-Charge, can be seen in the centre checking a transmission.

Four years ago he found an atmosphere of electric enthusiasm, freshness of outlook, surpassing ambition, and abounding vigour. Broadcasters then were a band of devoted zealots animated with the pure fire of inspiration. Arthur Burrows, Rex Palmer, Cecil Lewis, Jack Frost, P. F. Anderson, Stanton Jefferies, K. A. Wright, Captain Eckersley, and the General Manager, Mr. (now Sir John) Reith—this was the team of indefatigable pioneers that so impressed my friend.

Boundless Enthusiasm.

There they were, working night and day, thinking about broadcasting and broadcasting only, regardless of their own interests, eagerly receptive of all new ideas, feverishly anxious to welcome new talent. And what has happened since as the result of four years' development?

My friend described how several of his letters were ignored, and then, finally, he managed, after a fortnight of persistent endeavour, to gain admission to the sanctified presence of one of the new bureaucrats of Programme Administration. There his

This is the fourth of a short series of critically constructive articles on British Broadcasting, in which the reader will find an explanation of the origin, development, and evolution of policy of the B.B.C.

By THE EDITOR.

The B.B.C.—New Ideas and New Talent.

impression was one of well-ordered, symmetrical, smooth-running mechanism. Having braved the terrors of the protecting barrage, my friend was welcomed, not without courtesy: but it was the courtesy of cold, calculating distinction, rather than the courtesy of warm humanity.

When they got down to discussing ideas it became evident at once that the official was tied and manacled by red tape, by precedent, and by the dread of higher authority. There was no longer the same splendid enthusiasm to break new ground. It was rather the attitude of one whose job depended upon his taking no risks, even to the point of having nothing new, either in talent or in ideas. My friend ultimately fulfilled his engagement, but he admitted that it was not half as good as some of his earlier performances before the microphone. The cause of his falling off was the depression left on his mind by the pervading atmosphere of Savoy Hill. He felt that he had been in a perfectly organised factory.

Now, in deducing correct conclusions from my friend's impressions it is necessary, of course, to begin by discounting some of his artistic enthusiasms and by

allowing something for the inevitable encroachment of bureaucracy in the course of development. It is probably quite true that the spontaneous enthusiasms and the intensity of the very early days of broadcasting are not literally paralleled to-day. Human nature being what it is, such pioneering enthusiasm is bound to wane; such supreme indifference to self-interest must acknowledge hard facts.

More Ponderous Organisation.

Then again, in the old days, with only about two stations working, and with about three rooms to house the whole of the staff, the B.B.C. was a kind of small family affair. But it must be remembered that its listeners were correspondingly few. During the four years that have passed, the nucleus has become a national service and the concern of fifteen million people.

It has outgrown the Company form of administration and has become a State Corporation, responsible to Parliament through the P.M.G. This process could not have taken place without a certain formalising and a certain slowing down of procedure.

But, having entered these two *careats*, is there some residual truth in the criticism I have described? My alarm is due to the fact that I think that there is too much truth in it. Fortunately, however, I have enough faith in the adaptability and good sense of the B.B.C. to believe that once I have called attention to the danger it will lose no time in attempting to remove it.

(Continued on next page.)

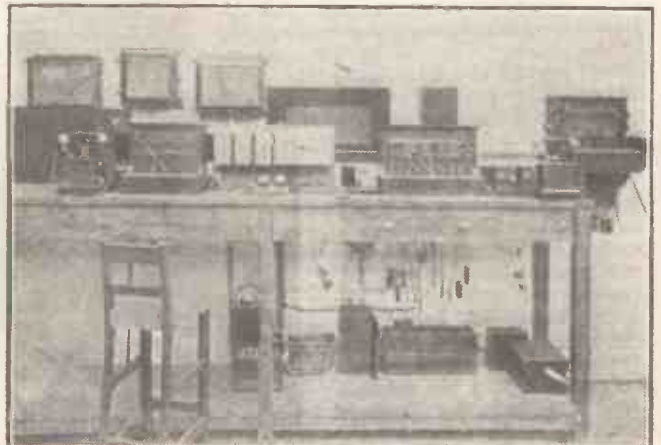

In the earlier days a complete control outfit was installed immediately behind the studio. Nowadays the control room may be some distance away.

AN EASY MISTAKE.

NO doubt readers of this journal have from time to time been disappointed to find that on joining up a newly-constructed receiver to the appropriate battery, aerial and earth terminals, the anticipated results of range and volume have failed to materialise. Unless the wiring instructions are followed implicitly a wrong connection can very easily be made, and the fault I located the other day in a

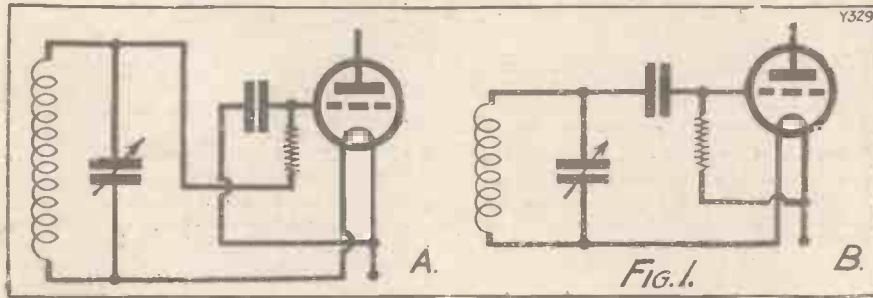

friend's receiver was clearly a case of a misunderstanding on his part. His knowledge of wireless and components was quite small, so perhaps he may be forgiven, but I pass on the tip in case others fall into the same trap.

Wrong Tags Connected.

The absence of signals was traced, finally, to the detector valve, where a grid leak and condenser had been employed of the usual combined pattern. That is to say, the grid leak and condenser were brought out to a single connection on one

side but were separated on the other side so as to allow the grid leak to be joined either to L.T. + direct or in parallel with the grid condenser, according to circuit requirements. In connecting up the leads the respective grid leak and condenser soldering tags had been mistaken, with the result that the grid leak was soldered to the top end of the grid tuning circuit, while the grid condenser made circuit with L.T. +.

The Actual Wiring.

Fig. 1A shows the arrangement and it will at once be obvious why the set failed to function. It was due to the presence

of such a high impedance (2 megohms) in the grid circuit, as compared with the relatively low impedance of the usual condenser. Reversing the connections to their correct orientation—i.e. Fig. 1B, brought about the radical change desired and the set is now working splendidly. It is really surprising how very elementary mistakes in wiring wholly upset a receiver's performance, so do not be disheartened if your set fails to come up to expectations on its initial trial, just retrace your connections and the reason will soon be forthcoming.

A SWITCH TIP.

PRACTICALLY all radio receivers are fitted with on-off push-pull switches these days. Unfortunately, push-pull switches are not standardised, and some are "off" when they are in, and others are "off" when they are pulled out. And when you change over from one set to another it may so happen that the switches in the new set work in the reverse direction, and because of this, one night you may leave the set switched on and waste a considerable amount of current, even if you do not entirely exhaust the L.T. battery.

A Safeguard.

To guard against this it is a good plan to leave a small pea lamp connected in parallel with the L.T. circuit of a new set for a few weeks. Thus there will be visual evidence when the set is switched on, for the small lamp will light up. A pea lamp consumes very little current and, in any case, after a short while it can be dispensed with. It is better to waste, if you can use that word in this case, a little extra current while the set is running than stand the risk of leaving it switched on all night running the L.T. battery right down.

ON SALE DECEMBER 1st.

The Only Shilling Radio Magazine Worth While.

"Modern Wireless."

Special Xmas Number with Full Size Blue Print FREE.

ORDER YOUR COPY NOW.

BRITISH BROADCASTING.

(Continued from previous page.)

What then are the practical manifestations of this particular disease? I should say that the first is the absence of any section or department whose sole concern it would be to accept and try out new ideas. Captain Eckersley has an excellent development department. This has no counterpart in his brother's organisation. New ideas quite frequently originate within the B.B.C. itself. There is, fortunately, quite a sprinkling of bright young men and women, both at Savoy Hill and in the country. These "spark" new ideas. But the sparking process is not nearly as active as it was.

Nobody's Business.

The idea having originated, what is to be done with it? It is nobody's business in particular. More than this, it seems most people's business to avoid handling any new idea. This is not unnatural, but it is definitely inimical to the advancement of broadcasting. The result is that the original minds are becoming discouraged.

If this is the case, with ideas originating within the B.B.C. what earthly chance have new ideas coming from outside? No doubt, most of these are promptly and courteously acknowledged and then duly pigeon-holed. Some few may trickle through. But what is fundamentally wrong is that new ideas, whether from within or from without, should have to fight their way through a lot of unnecessary opposition instead of being warmly welcomed. The result is that "peaks" have almost disappeared from programmes, which follow a steady level, no doubt excellent on the average, but more reminiscent of consistently good workmanship, in the sense of mass production, than distinctive achievement in artistic endeavour.

Carried to its logical conclusion, the

present discouragement of originality will deprive B.B.C. programmes of what still is left to them of individuality and "flair." The urgency of providing special machinery for dealing with new ideas cannot be over-emphasised. And there is another point of equal importance. The B.B.C. must be prepared to spend money on new ideas. There should be no question of cast-iron budgeting for this end of the work.

Question of New Talent.

These criticisms also extend to the region of new talent for programmes. There is at present altogether too much difficulty put in the way of promising artistic personnel. Young singers of real and proved promise have sometimes to wait months for an audition, and just as long afterwards for an engagement.

As for capable and ambitious stage artistes, the difficulties are even greater. It may be quite unfair to the B.B.C., but the impression does exist and is gaining ground that a certain limited and specially favoured group of artistes has secured a practical monopoly of B.B.C. patronage.

While there is, probably, no substantial ground for such a serious accusation, there is, nevertheless, crying need for the exercise of more intelligence and more humanity on the artistes' recruiting side of the B.B.C.



2 LO's transmitter, which is probably the best of all the British transmitters in point of quality.

The "REGIONAL" TWO



THE best two-valve receiver for all-round work is without doubt a detector and one L.F. stage, with transformer coupling. Such a set will give loud-speaker results on the local station at distances up to about 10 miles, in fact, with a good aerial and sensitive

Here is a receiver which, handsome in appearance and giving first-class loud-speaker results, is both easy and cheap to make. It was designed, built, and tested by the "P.W." Research and Set Construction Department.

Described by
A. JOHNSON RANDALL.

cut down the total cost of a set very considerably, thus bringing it within the reach of those who find the price of the "De Luxe" type of receiver rather in excess of the figure they are prepared to pay.

The set described, therefore, has been designed with a view to fulfilling the needs of the home constructor requiring a simple, moderately-priced and efficient two-valver.

The Circuit.

Reference to the theoretical diagram will show that the circuit is of an up-to-date type. The aerial-grid circuit consists of the well-tried "aperiodic" arrangement, which has proved so very successful from the standpoint of selectivity combined with maximum signal strength. Three tappings are taken at points along the winding, thus permitting various degrees of selectivity

(Continued on next page.)

COMPONENTS REQUIRED.

- 1 Cabinet and baseboard, size 12 in. x 7 in. x 9 in. (Peto-Scott). (Artercraft, Camco, Caxton, Picket, Raymond, etc.)
 - 1 Panel, 12 in. x 7 in. x $\frac{1}{8}$ in. (Radion). (Any good branded material.)
 - 1 .0005 slow-motion variable condenser (Jackson Bros.). (Any good make.)
 - 1 .0003 slow-motion variable condenser (Jackson Bros.). (Any good make.)
 - 1 6-contact coil former and base (Becol).
 - 1 On-off switch (L. and P.). (Igranic, Lissen, Lotus, etc.)
 - 1 .0003 fixed condenser (Dublier). (Igranic, Lissen, Mullard, T.C.C., etc.)
 - 1 Grid leak, 2 megohms (Mullard). (Dublier, Igranic, Lissen, etc.)
 - 2 Valve Holders (Lotus). (Any good sprung type.)
 - 1 H.F. choke (Ormond). (Bowyer-Lowe, Lissen, R.I. & Varley, etc.)
 - 1 I.F. transformer (Lissen). (Any type of moderately low ratio.)
 - 2 Baseboard-mounting rheostats (Lissen). (Igranic, etc.)
 - 1 Terminal strip, approx. 6 in. x 1 in. x $\frac{1}{4}$ in.
 - 8 Terminals.
 - 3 Aerial sockets, 1 plug for same (Clix). (Eelex or similar type.)
 - 2 Wander plugs for G.B. + and -.
- Some flex and tinned copper wire (or any of the standard special materials for wiring, such as Glazite, Junit, etc.)

so long as they are of reputable manufacture, can be moderately-priced ones.

The aerial and reaction coils can be home wound, and for that matter, the H.F. choke also, but in the latter case the job is rather tedious owing to the large number of turns required and the comparatively thin wire used. In this way it is possible to

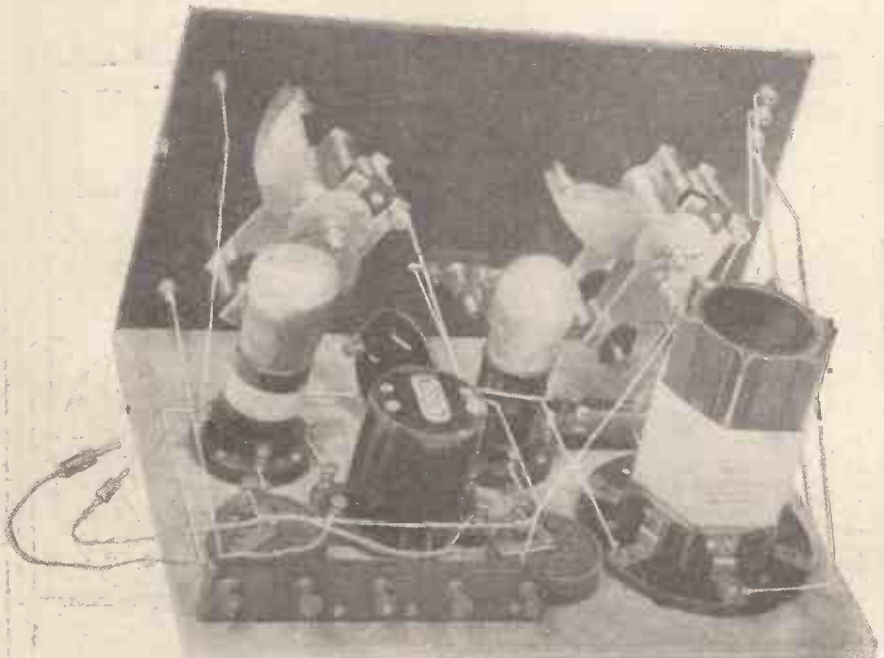

This is the back-of-panel view of the assembled set with the coil and valves in position.

speaker I have known quite good results to be obtained at 15 miles. In addition, it is usually possible, with this combination, to do a certain amount of "DX" work. For instance, a large number of Continental stations will come in at very good strength on the 'phones, some of them probably on the loud speaker.

A receiver of this type need not cost a great deal to make. There are, of course, certain essential components, but these,

THE "REGIONAL" TWO.

(Continued from previous page.)

to be obtained. Apart from this the signal strength with a given tapping on any coil tends to decrease when the wave-length is increased beyond the limits between which the chosen tapping gives its optimum results. To put it more simply, a coil will not give maximum signals over more than a small band of wave-lengths if only one tapping is employed. The coil used in this set, however, will give really good results over the whole of the lower B.B.C. band. Reinartz reaction is obtained by means of a small "bunch"-wound winding on the lower end of the former;

Constructional Details.

The detector circuit is tuned by a .0005 variable condenser with slow-motion control. Although it is not essential to purchase this type of condenser I strongly advise the constructor to do so, since on any but the local station he will find the refinement well worth while. This will be especially noticeable on weak stations.

A leaky-grid detector followed by a transformer-coupled L.F. stage completes the circuit. In order that the L.F. valve may be correctly adjusted for distortionless loud speaking, a separate H.T. tapping and grid-bias flexible leads are provided. It is intended that the grid battery should be placed inside the cabinet, preferably at the back. The standard Siemens' grid battery has a flap provided which permits it to be fastened in a vertical position with the aid of a couple of drawing pins, or tacks.

The actual constructional work will not be found very difficult. Three $\frac{3}{8}$ -in. holes will be required for the purpose of mounting the two variable condensers, and the filament holes are fairly small. For the three sockets to which the coil windings are taken a $\frac{7}{32}$ drill will suffice. The same drill could also be used for the terminals, provided these have 2 B.A. shanks. Finally, five small holes will be necessary along the bottom edge of the panel for the screws which

secure the panel to the baseboard. The holes for these screws should be countersunk with a rose bit, which may be obtained for about one shilling from any tool shop.

The terminal strip at the back of the baseboard can be a small piece of ebonite,

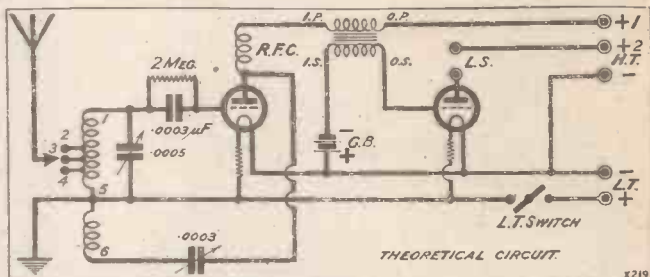

6 in., by 1 in. by $\frac{1}{4}$ in., but its size is not important so long as there is plenty of clearance between the terminals.

Place the six-contact coil base so that contact No. 1 is near to the terminal on the grid condenser to which it is joined. This will be the best position for easy wiring. When joining the wire from the L.T. + terminal to the filament switch be careful to place it in a position so as not to foul the detector valve. Apart from this point the remainder of the wiring is quite straightforward. Note that the two flexible connections for grid bias - and + are taken direct to IS on the transformer and L.T. - respectively. The lead which is joined to IS is G.B. -, and it is the wander plug attached to this wire which is varied according to the value of grid bias required.

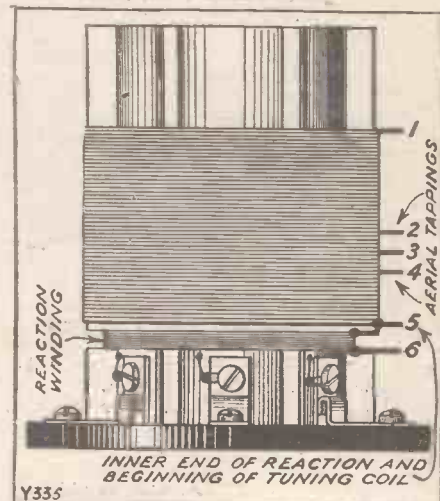
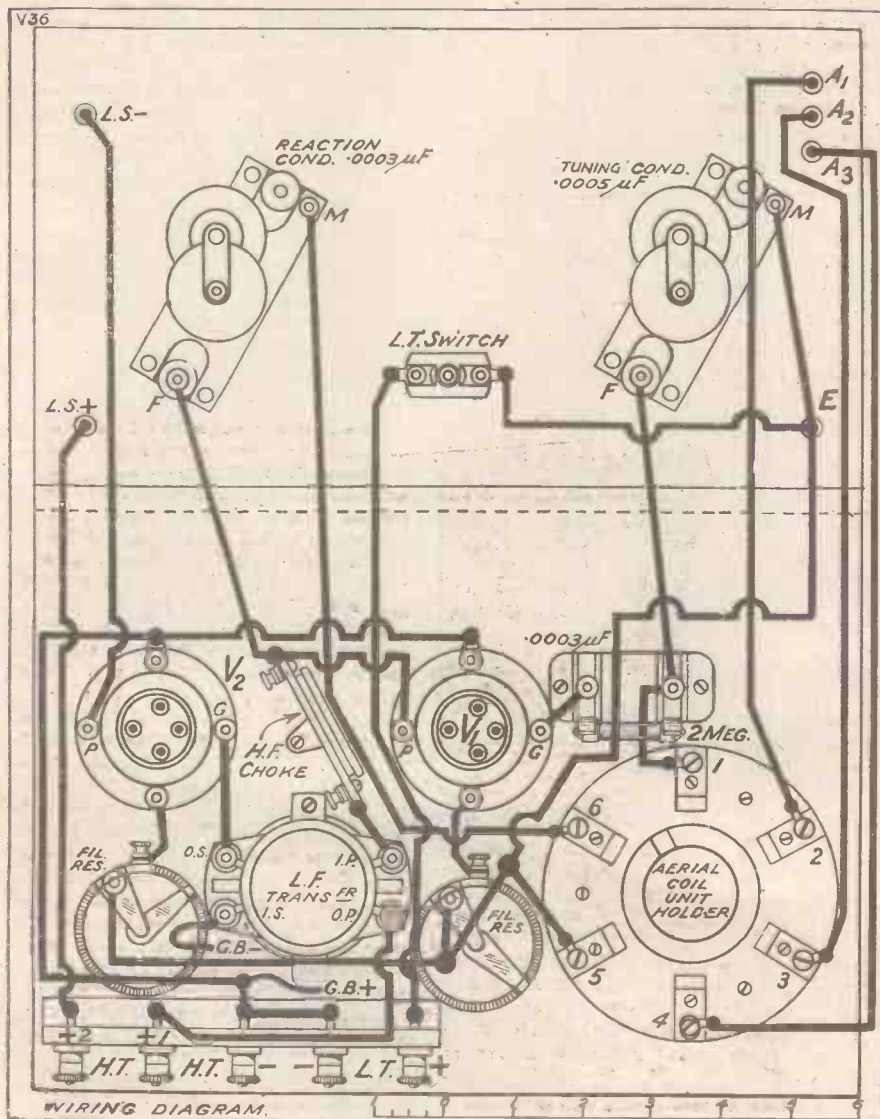

The other wander plug (G.B. +) is inserted in the + socket on the grid battery and left there.

Having completed the wiring, the next plan is to wind the coil. The secondary winding consists of 60 turns of No. 22 D.C.C. on a 3-in. ribbed former and occupies a length of 2 inches. The upper end of this winding is taken to contact No. 1. Commencing from this end 35 turns are laid on in a clockwise direction. A tapping is then taken and joined to contact No. 2. Another five turns are then wound on and a second tapping is taken to contact No. 3. Then five more turns are laid on and another tapping taken, this time to contact No. 4. The winding is then completed by laying on fifteen more turns, making 60 in all. The

(Continued on next page.)

THE "REGIONAL" TWO.

(Continued from previous page.)

lower end of the coil goes to contact No. 5. This is also the commencement of the reaction winding, which consists of 20 turns of No. 34 gauge D.S.C. "bunch" wound in a clockwise direction below the secondary winding. The beginning of the reaction coil, as stated, is joined to contact No. 5, and the end of the winding to contact No. 6.

Place the completed coil in its holder and the set is ready for work. To operate the receiver insert two valves in the detector and L.F. sockets. Practically any valve will

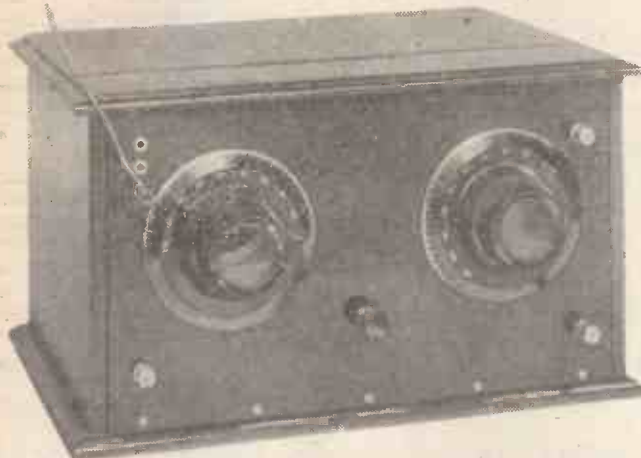

Varying degrees of selectivity can be obtained by plugging the aerial lead into one or other of these sockets.

work as a detector, but for maximum results I suggest a valve having an impedance of about 20,000 ohms and the highest

POINT-TO-POINT WIRING.

Join top aerial socket to contact 2 on coil base. Join middle aerial socket to contact 3 and bottom socket to contact 4.

Join contact 5 to moving vanes of tuning condenser, to earth terminal, to one side of filament switch, and to arms of both filament rheostats. Join other side of each filament rheostat to one filament terminal on its respective valve holder.

Join L.T. + terminal to remaining terminal on filament switch. Join L.T. - to H.T. -, to flexible lead for G.B. +, and to remaining filament terminal on each valve holder.

Join contact 1 on coil base to one side of grid condenser and leak, and to fixed vanes of tuning condenser.

Join other terminal on grid condenser and leak to grid terminal of first valve holder. Join plate of first valve holder to one side of H.F. choke and to fixed vanes of reaction condenser.

Join moving vanes of reaction condenser to contact 6 on coil base.

Join other side of H.F. choke to I.P. on L.F. transformer. Connect C.P. to H.T. + 1 terminal. Join I.S. to length of flexible wire for G.B. -. Join O.S. to grid of second valve holder. Join H.T. + 2 to lower L.S. terminal and connect upper L.S. terminal to plate of second valve holder.

This completes the wiring.

possible amplification factor. It is impossible to give a complete list of suitable valves because there are so many. In general, however, any valve suitable for H.F. amplification should give good results as a detector.

The Marconi and Osram D.E.L. 610, Cossor 610 H.F., Mullard P.M.5 X all make good rectifiers, and, of course, their equivalents in the 2- and 4-volt classes are quite satisfactory. In the I.F. socket, if a loud speaker is to be used, I recommend you to employ a small power valve. In the 6-volt class we have such valves as the D.E.P. 610, P.M.6, B.T.H. B.4, Cosmos S.P.55/R, Cossor 610 L.F., etc. In the 2- and 4-volt classes there are a whole list of similar valves.

Connect up the L.T., H.T. and grid batteries. The terminals on the strip looking at the back of the baseboard are, left to right, H.T. + 2, H.T. + 1, H.T. -, L.T. - and L.T. +. H.T. + 2 feeds the last valve and the lead from this terminal is taken to the higher voltage tapping on the battery. I suggest an H.T. battery having a value of at least 100 volts, with tappings at every 3 or 6 volts. Place the H.T. + 2 wander plug in, say, the 100-volt tapping, and the H.T. + 1 plug in the 60-volt tapping. Connect up the loud speaker or

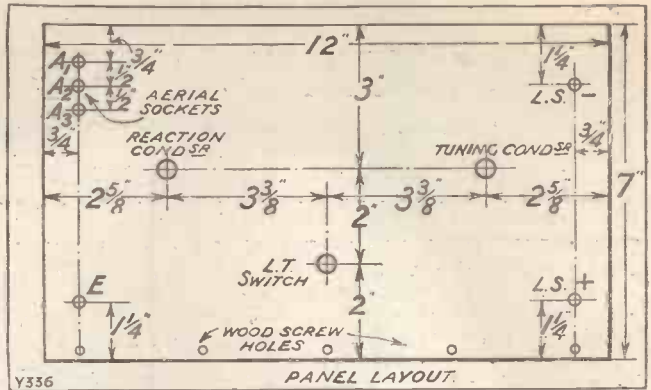

phones, also aerial and earth. Use the highest aerial tapping (contact No. 2). Switch on the valves and rotate the aerial tuning condenser until you hear the local station. The reaction condenser should be at its minimum position, that is, with the moving vanes right out.

Concluding Hints.

Now try increasing the value of the reaction condenser and signals should increase in strength until a point is reached where oscillation occurs.

The reaction condenser must always be kept adjusted below this point. Try different aerial tappings and H.T. voltages until you obtain the best results. If you wish to search for distant stations rotate the aerial condenser very slowly, keeping the reaction condenser just below the position where self oscillation occurs.

If you wish you can increase selectivity by using the smallest tapping on the aerial coil winding (Contact No. 4).

The grid bias should be adjusted in accordance with the valve maker's instructions, and with ordinary valves a 9-volt grid battery will be ample.

Next week I shall describe the construction of a coil for Daventry.

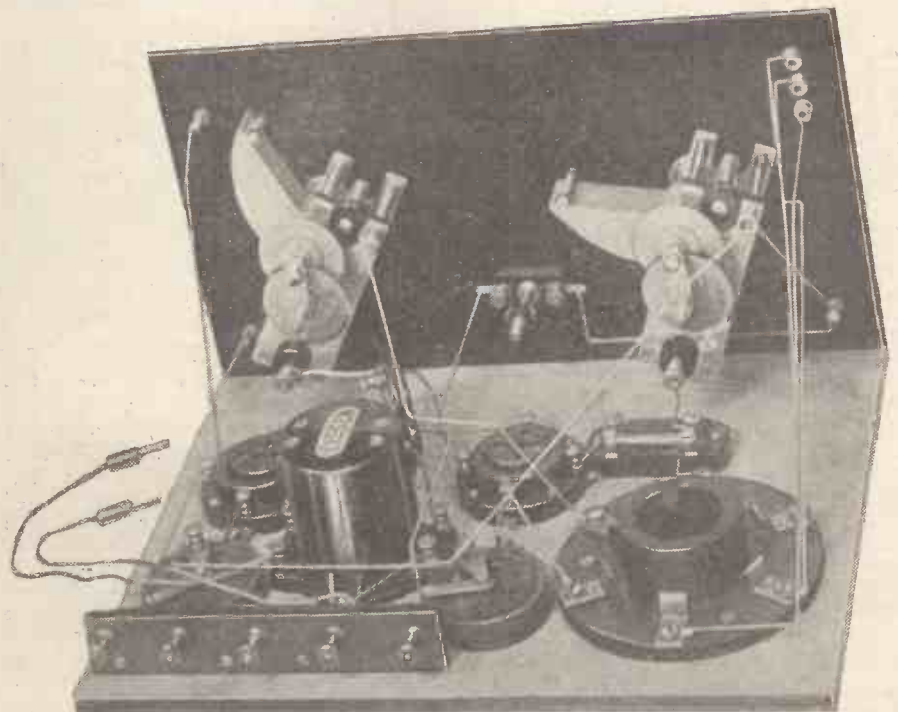

The H.F. choke is just behind the L.F. transformer. The two leads on the left carry the grid-bias plugs.

CURRENT TOPICS.

"Dreadful!"—The Heaviside Layer—Down-coming Waves.

By THE EDITOR.

SIR JOHN REITH, Director-General of the B.B.C., recently delivered himself of some candid home truths about broadcasting which, to say the least of it, have caused a good deal of surprise.

Speaking at a meeting of the Manchester Luncheon Club, a few days ago, he asked his hearers not to judge broadcasting by programme items they might periodically hear.

"Don't judge them," he said, "by children's hours or variety entertainments. I know they are dreadful. I haven't much opportunity of listening in my own room, but there are occasions when I cannot get across the room quickly enough to turn my set off."

Need for Improvement.

When the executive head of a great public service corporation utters words like this in public, which are widely reported by the Press, one can only arrive at one of two conclusions, namely, that Sir John considers the quality of the entertainment provided during the children's hours and the variety programme hours very bad; or else the children's hours and the variety hours in the programmes bore him, however fine the quality of the broadcasters.

If the latter is the true expression of Sir John's remarks, then the only harm done is the obscure way in which he gave vent to a purely personal opinion regarding the appeal certain items in the programmes made to him; but if he made these remarks because he felt the children's hour programmes, and the variety programmes, were, at times, of inferior quality, then he lays himself open to criticism.

Apart from the question of criticising his own staff and their programme work in public, one hardly expects the head of the B.B.C. to admit—apparently with some real feeling—that sections of the programmes of the B.B.C. are "dreadful." If he really believes that, surely it is up to him to see that they are improved?

Supposing Mr. Baldwin said, at a big public meeting, "Don't judge the Government by the work of the Home Secretary and the Chancellor of the Exchequer: I know they are dreadful," what should we think of Mr. Baldwin and his Government? The answer would probably be, "Clear out at the next General Election!"

Reflected Radiation.

But that is where Sir John Reith has the joke on us. In the words of the classics, "There ain't goin' to be another B.B.C. election"—at least, not for a long, long time. Let us hope Sir John will have seen to it, in the meanwhile, that certain programme items arranged by his staff are no longer "dreadful." Well, well—it's a queer world!

It is a well-known fact that wireless waves transmitted from a station are radiated upwards until they reach a height where the

atmosphere is highly ionised and, consequently, electrically conductive. From this ionised layer, generally known as the Heaviside layer, the electro-magnetic waves are curved over and deflected down towards the earth again. Therefore, waves of this nature which have travelled through the upper atmosphere are more or less free from various objects close to the earth which have the property of absorbing wave energy.

Waves travelling in the upper atmosphere are consequently able to travel considerably longer distances than the waves which have passed closer to the earth.



2 N M. The handsome and well-equipped studio from which Mr. Gerald Marcuse, of Caterham, "tells the world" on short waves.

One of the reasons why 2 N M cannot be heard, say, at forty miles from Mr. Marcuse's station, but can be heard clearly in Australia, is due to what is known as a "skip" distance effect, but according to the angle made when the waves strike the Heaviside layer and are deflected to earth again, so just about the place where, when deflected, they strike the earth, the signals will be extremely loud and clear, although perhaps thousands of miles from the source of origin.

These downcoming waves, as they are called (that is, waves which, when deflected

by the Heaviside layer, return to earth) have been the subject of scientific investigation by Dr. R. L. Smith-Rose and Mr. R. H. Barfield, and interesting details are given in the current number of the Proceedings of the Royal Society.

The record describes measurements made at the Radio Research Board's Station at Slough on the transmissions made from four of the B.B.C. stations covering a period of about six months.

Interesting Observations.

In the case of the transmissions from 2 L O at a distance of twenty miles the signal strength was practically constant both by day and night over a period of several months, while the normal day strength from the Newcastle station, 245 miles away, was, on the whole, weak, but increased to nearly twelve times the strength during the night periods of transmission.

These results are instructive because they show that in the case of London's transmissions received at Slough the downcoming waves are weak compared with the ground waves, but the reverse holds good for the much greater distance of the transmissions from the Newcastle station.

The paper points out that the variation in strength and polarisation of the atmospheric wave results in the fact that the received signal strength in the latter case is always changing, thus explaining fading. In the hours of daylight the sunshine ionises the lower portions of the earth's atmosphere, with the result that the upgoing wave is very weak, thus giving the explanation for the fact that the signal strength is due to the ground wave by itself.

Records made over a period of six months from May to October indicate that there is a tendency for the downcoming waves to decrease in intensity as the season progresses, but the authors point out that further measurements over a much longer period will have

to be made before any definite conclusions can be arrived at with regard to this matter.

**DON'T FORGET THE
"P.W."**

SPECIAL XMAS NUMBER

Out Dec. 8th. Price 3d.

The SAME OLD TALE but—

Here we are again—the ghostly violinist, the man smoking the same old pipe in the same armchair, you've seen it all before, of course you have, but here's the difference, you've never heard anything like the Ormond. No—never!!

Such natural tone, such marvellous distinctness with complete absence of discordance. Of course it's different, different design, different driving unit, different cone. That is why listening in with the Ormond really creates the illusion of actually hearing the artist in the room.

A command performance as often as you wish with the

ORMOND

PRICE

£3-3-0

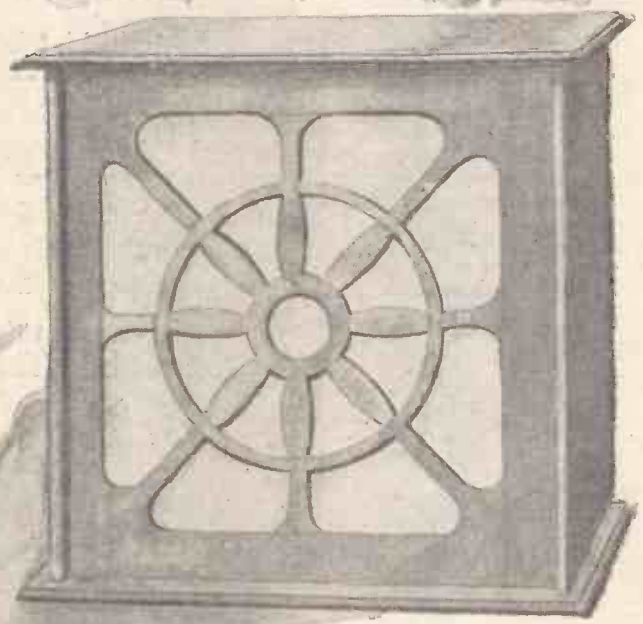

Let us send you particulars and arrange a demonstration. You know the common faults of loud-speakers, see the Ormond in its handsome Jacobean oak cabinet, hear it and then judge if the Ormond could be bettered on

**PERFORMANCE,
APPEARANCE AND PRICE.**

**199-205 PENTONVILLE RD.,
KING'S CROSS, LONDON, N.1**

Telephone : Clerkenwell 9344-5-6.
Telegrams : "Ormondengi, Kinross."

Factories : WHISKIN STREET AND HARDWICK STREET, CLERKENWELL, E.C.4

Continental Agents : Messrs. Pettigrew and Merriman, Ltd., "Phonos House," 2 and 4 Bucknall Street, New Oxford Street, W.C.1



**Shut
your
eyes**

IF, some evening, you lie back in your chair and, soothed by the music from your **BROWN Cabinet Loud Speaker**, you shut your eyes, you will have a thrilling experience. The broadcasting will no longer be broadcasting, and the loud speaker will be transformed—to your ears—into the singer himself. Soon, because the realism of it is so uncanny, you will rouse yourself and come to earth again to make sure that you are not dreaming. Then, when you are satisfied that you are still alone, you will sink again into oblivion, to capture the thrill once more.

If you would this experience were yours, ask your **Wireless Dealer** to demonstrate the **BROWN Cabinet Loud Speaker** to you. He will be proud to. £6. 6s. is its cost.

S. G. BROWN, LTD., Western Avenue, North Acton, London, W.3. Showrooms: 19, Mortimer Street, W.1.; 15, Moorfields, Liverpool; 67, High Street, Southampton. Wholesale Depots throughout the Country.



BROWN
CABINET LOUD SPEAKER

The Lure of Short Waves

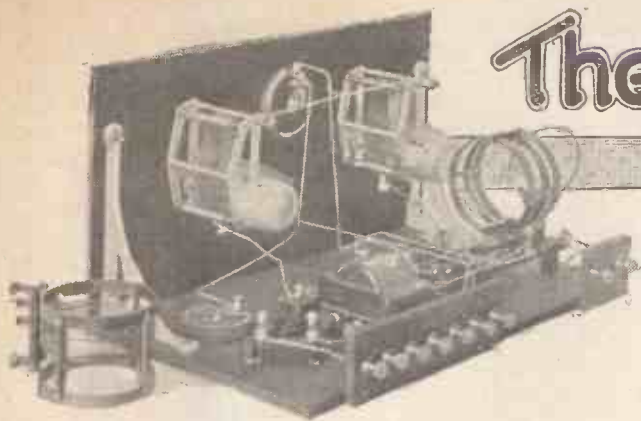

"No one who builds a short-wave receiver ... ever gives it up again ..."
 An article on the fascination of short-wave reception.
 By W. L. S.

THE fact that no one who builds a short-wave receiver and spends a fortnight or so listening on it ever gives it up again speaks for itself. One may query the truth of this assertion, but there is very little room for doubt.

There may be a few who are unlucky enough not to meet with success at their first attempt to probe the mysteries of this branch of radio reception, and who, perhaps, in a fit of discouragement, decide that short-wave work is "no good." These are, however, from the writer's experience, such a very small minority that they are hardly worth considering.

The short wave-lengths are probably the most useful, and certainly the most interesting, part of the spectrum of wireless waves; by short wave-lengths I mean anything below 100 metres, going down as low as 5 or 8 metres. If one only uses common sense and a little care, the simplest type of receiver will yield the most astounding results, and, moreover, the simple receiver is practically the only type that will work!

Simple Sets Best.

Neurodynes with their terrors for the uninitiated may be put out of all consideration for high-frequency amplification has hitherto not been persuaded to operate on these short waves in a manner efficient enough to render it worth while. What may be termed the "universal" receiver for this purpose is the favourite detector and one stage of L.F.

There is, after all, no mystery attaching to the properties of short waves now. Some years ago the amateur transmitters were bodily "removed" from the 1,000-metre wave which they had been allowed to use, and were given instead the 440-metre wave, and a band ranging from 150-200 metres, which was not then believed to be of the slightest use to anyone. They soon proved it to be the better of the two waves, and evacuated the 440-metre band with joy as soon as the organised broadcasting commenced.

Useful Wave-lengths.

One or two daring spirits decided to probe still lower, and the 90-100-metre band was found to have even better properties, for signals radiated with quite low power managed to make themselves heard in the United States and, later, even in New Zealand. Not content with this triumph, they proceeded in their downward journey, to find that the waves between 30 and 45 metres were vastly more useful for their purpose even than the 90-100-metre band.

The chief advantage about the 45-metre

band was that it was a "daylight" wave, and that the work which was interrupted on the longer wave-lengths with the coming of daylight could be carried on quite well on 45 metres. And so the "great trek" went on, and is still going on, for at the present time the 20-metre band is receiving rather more attention than the others, and new properties are still being discovered.

Large Number of Stations.

It was not, however, until fairly recently that commercial use was made of wave-lengths below 100 metres. They were not considered suitable for broadcasting at first on account of their apparently erratic properties. It was soon found that these properties were due to the low powers used by the amateur transmitters, some of whom cover great, but inconsistent, ranges with powers of 2 watts or so! When higher powers were employed, quite naturally, more consistent results were obtained, as witness the triumphs of the famous K D K A on its first wave-length of 109 metres, afterwards dropping to 65 metres.

The results of all these progressions is rather a happy one for the amateur listener, for there are now numerous distant broadcasting stations working on the short waves that were once "useless," and in addition

to these there are literally hundreds of amateur stations working in all parts of the globe. There is no reason why all these innumerable stations should not be received with the simple "det. and mag."

The chief point requiring attention, after the construction of the set, with which it is not proposed to deal, is "what to listen for, and how." It will be assumed that the reader has constructed a short-wave receiver to one of the many excellent designs published in "P.W." from time to time, and is now ready for anything.

Principal S.-W. Broadcasters.

If he can read Morse, his lot is doubly enjoyable. If, however, he is confined to the reception of speech and music, he will still find ample to keep him busy. The broadcasting stations will be dealt with first, and the amateur traffic afterwards.

The principal broadcast stations are the three or four short-wave branches of W G Y (the G.E.C. at Scheneectady), the two main stations of K D K A, and Eindhoven, Holland. The latter, using the call-sign of P C J J, works on about 30 metres, his regular times at the date of writing (subject to alteration) being Tuesdays and Thursdays

(Continued on next page.)

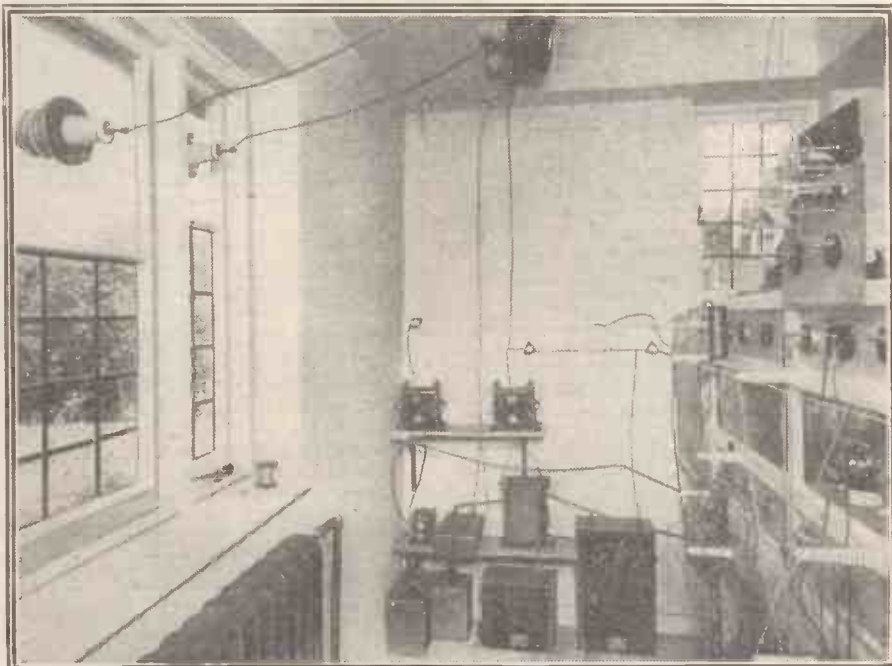

The lead-in and the smoothing gear at Mr. Marcuse's amateur station, 2 N M. ("P.W.," Photo-Exclusive.)

THE LURE OF SHORT WAVES.

(Continued from previous page.)

from 17.00 to 20.00 G.M.T. He is often working, however, at other times, and is usually to be heard for half an-hour or so every evening of the week.

Sydney and 5 S W.

After 7.30 G.M.T. he is sometimes liable to fade out, and by the time this appears in print he may be disappearing even earlier. This need not worry the reader, however, for it appears to be a fairly safe general rule that when Eindhoven starts to fade out the Americans start to come in! 2 X A F, Schenectady, works on 32.79 metres, and therefore obeys most of the laws that govern the transmissions from P C J J. He is quite easy to pick up about 10 or 10.30 most evenings, and though not so strong as P C J J (who can only be compared with 2 L O at ten miles or so) is very good indeed, and on a good night may often be put on the loud speaker with two valves in use.

2 X A D, another transmitter at the same station, works on about 22.5 metres, and is usually even stronger than 2 X A F. K D K A works on 65 metres, and also 14 metres, and although the latter transmission requires a certain amount of care in tuning-in, and a reasonably efficient receiver on account of the rather short wave-length, it is considerably stronger than any of the others.

In addition to these "milestone" stations, there is 2 M E, Sydney, Australia, working on 29 metres, and 2 N M, the station of Mr. Marcuse, at Caterham, famous in connection with "Empire Broadcasting," 5 S W (Chelmsford) on 24 metres and many others whose times are uncertain.

Amateur Transmissions.

Regarding the amateur transmissions, these are, mostly, of course, in Morse code, although quite a fair number of telephony experiments are carried out from time to time. Naturally, the Morse signals carry much further with a given power than telephony would, and are therefore more interesting both from the transmitter's and the receiver's point of view.

There are so many different countries engaged in the "amateur game" at present that each has been allotted an "intermediate" consisting of two letters which must be sent in front of the call-sign itself, to serve as an indication of the nationality of the transmitting station. A list of these "intermediates" appears with this article, and the method of using them is as follows:

French 8 A B, for example, uses the prefix for France, E F. United States I A W would, of course, use N U. The French station calling the American would, therefore, send "I A W I A W I A W N U E F 8 A B 8 A B 8 A B." The American replying would send: "8 A B E F N U I A W."

It is, therefore, the two letters immediately preceding the call-sign that indicate the nationality of the station. As far as wave-lengths are concerned, amateur stations may be heard practically anywhere between 8 metres and 100 metres!

British stations are licensed for 23 and

45 metres, and most of the other European countries may be heard during the hours of daylight on the 45-metre wave. After dark the distant stations begin to come through on this wave-length, and by sitting through the night it is possible to hear a station in every country on the earth!

The American stations predominate, and the writer has logged 150 different United States amateurs between 10 p.m. and midnight on the 38-42-metre range of wave-lengths. On 20 metres the Americans may be heard during the winter at as early an hour as 6 p.m., and all through the summer one does not have to wait till after 10.30 or so.

The Australian and New Zealand amateurs are also to be heard fairly early in the evening, and also at about the same time (6 a.m.) in the morning. No definite

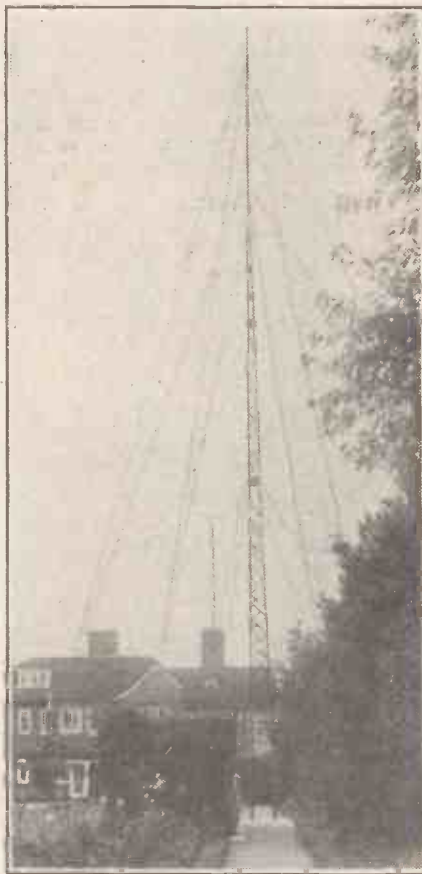

The main aerial mast at 2 N M.

rule can really be given, however, for the times at which they are most easily heard depend upon the wave-lengths they use.

One thing is certain, however, and that is, that with a short-wave receiver and a little perseverance it does not take one long to become so interested in the work and to build up such a circle of "acquaintances" all over the world that one will never give up this branch of reception.

Amateur "Intermediates."

EUROPE.

EA: Austria.	EN: Holland.
EB: Belgium.	EP: Portugal.
EC: Czecho-	EQ: Bulgaria.
	ER: Rumania.
	ES: Finland.
ED: Denmark.	ET: Poland and
EE: Spain.	
EF: France.	Latvia.
EG: Great Britain.	EU: Russia.
EH: Switzerland.	EV: Albania.
EI: Italy.	EW: Hungary.
EJ: Jugoslavia.	EX: Luxemburg.
EK: Germany.	EY: Greece.
EL: Norway.	EZ: Zone of the
EM: Sweden.	Straits

ASIA.

AA: Arabia.	AN: Nepal.
AB: Afghanistan.	AO: Oman.
AC: China.	AP: Palestine.
AD: Aden.	AQ: Iraq.
AE: Siam.	AR: Syria.
AF: Indo-China.	AS: Siberia.
AG: Georgia.	AT: Turkey.
AH: Hedjaz.	AY: Cyprus.
AI: India.	AZ: Persia.
AM: Malay States.	

AFRICA.

FA: Abyssinia.	FN: Nigeria.
FB: Madagascar.	FO: Union of S.-
FC: Belgian Congo.	
FD: Angola.	Africa.
FE: Egypt.	FP: Portuguese
FF: French W.	Guinea.
	FQ: Cameroons.
	FR: Rio de Oro.
FG: Gambia.	FS: Sierra Leone.
FH: Italian Somali-	FT: Eritrea.
land.	FU: Rio Muni.
FI: Libya.	FV: French Somali-
FJ: Somaliland Pro-	land.
tectorate.	FW: Gold Coast.
FK: Kenya.	FX: Seychelles.
FL: Liberia.	FZ: Mozambique.
FM: Morocco.	

NORTH AMERICA.

NA: Alaska.	NN: Nicaragua.
NB: Bermuda.	NO: British Hon-
NC: Canada.	duras.
ND: Dominican Re-	NP: Porto Rico.
public.	NQ: Cuba.
NE: Newfoundland.	NR: Costa Rica.
NF: Bahamas.	NS: Salvador.
NG: Guatemala.	NT: Haiti.
NH: Honduras.	NU: U.S.A.
NI: Iceland.	NX: Greenland.
NJ: Jamaica.	NY: Panama.
NL: Lesser Antilles.	NZ: Canal Zone.
NM: Mexico.	

SOUTH AMERICA.

SA: Argentina.	SK: Falkland Islands
SB: Brazil.	SN: Ascension Is-
SC: Chile.	land.
SD: Dutch Guiana.	SO: Bolivia.
SE: Ecuador.	SP: Peru.
SF: French Guiana.	SU: Uruguay.
SG: Paraguay.	SV: Venezuela.
SH: British Guiana.	

OCEANIA.

OA: Australia.	OH: Hawaii.
OD: Dutch East	OI: Micronesia.
Indies.	OP: Philippines.
OE: Melanesia.	OZ: New Zealand.

—ON SALE NEXT WEEK—

SPECIAL XMAS NUMBER MODERN WIRELESS

INCLUDING FULL-SIZE BLUE PRINT FREE

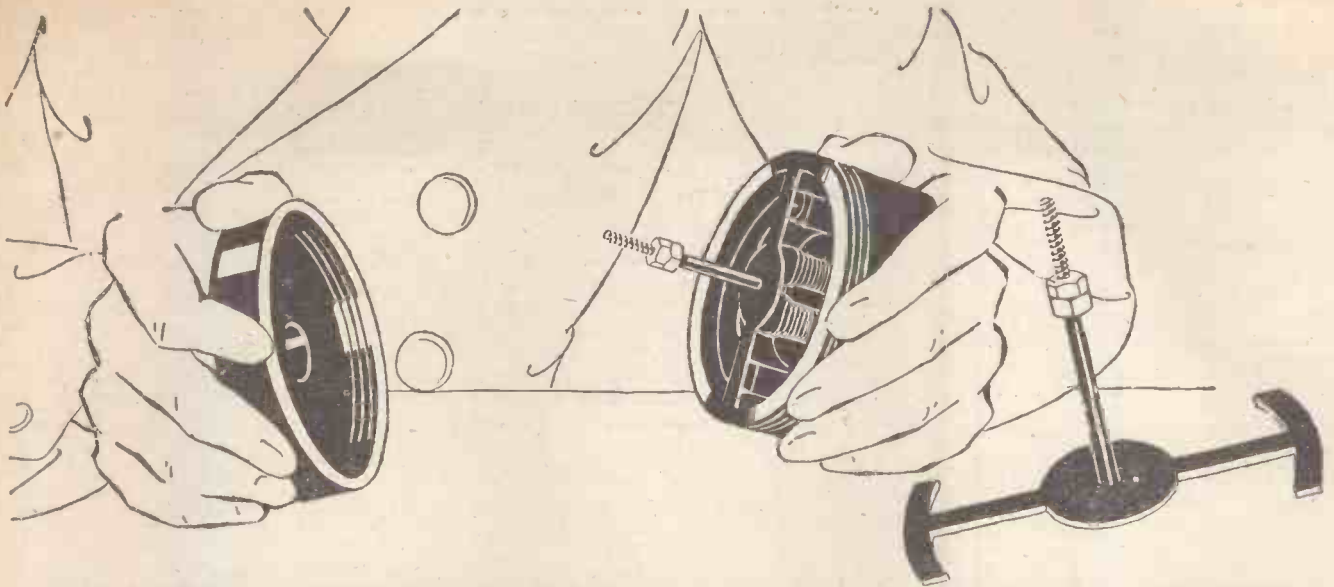

THE WONDERFUL THINGS YOU CAN DO WITH A LISSENOLA UNIT AND A LISSENOLA REED

THE LISSENOLA REED is a unique attachment which can be bought for 1/-. By substituting this for the diaphragm of the LISSENOLA Loud Speaking Unit you can make any type of loud speaker that works on the reed principle. Endless experiments can be tried. No other such attachment is made. No other loud speaking unit offers you the same facilities for making so many kinds of loud speakers. Get one and try these experiments for yourself.

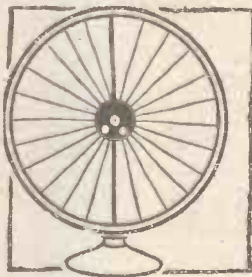

Many experimenters have made, with a sheet of parchment (obtained from a law stationer's) or other suitable paper, and two wooden hoops (such as are used for needlework) a plated diaphragm loud-speaker. A Lissenola Loud Speaking Unit, mounted on a cross-bar, with a Lissenola Reed to transmit the vibrations to the paper diaphragm, will complete the loud-speaker.

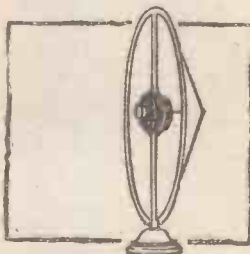

A cone diaphragm can be made with a little care from card or metal. Here again a Lissenola Loud Speaking Unit should be mounted with a Lissenola Reed. The centre of the cone should be pierced, the thread of Lissenola Reed inserted and locked on with the nuts provided. The tension can be adjusted by these nuts.

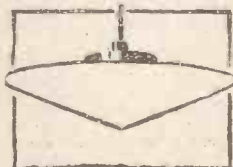

The cone type loud speaker can be used in many ways. For instance, it can be suspended from the ceiling as shown in the illustration. The Lissenola Loud Speaking Unit and the Lissenola Reed would be hidden from view. The cone diaphragm can be varnished or given a "Chinese lacquer" finish.



The Lissenola Reed will transmit the powerful vibrations from the Lissenola Loud Speaking Unit to any type of diaphragm sound distributor. A piece of 3-ply wood will act as a "sounding-board" by locking on it the Lissenola Reed. Or again, the Lissenola Reed can be held against the centre of a window pane, and the music will be heard clearly. The experiments you can make are endless.



Base of Lissenola Loud Speaker.

THE LISSENOLA
34/-
Complete.



You can obtain this full-sized, full-toned, full-powered Lissenola Loud Speaker complete for 34/- The Lissenola Loud Speaking Unit is embodied in the base and can easily be unscrewed in order that the experiments described here can be made. All you need in addition is a Lissenola Unit Cap (1/6).

THE CRYSTAL LOUD-SPEAKER CIRCUIT.

The Editor, POPULAR WIRELESS.
Dear Sir,—As a non-technically-minded reader, I wish to reply to Mr. Goldstein's assertion that the crystal circuit suggested by Mr. Webb is out of question.

He maintains that secondary voltage will be out of phase, but how much the following will show:

$$\frac{180,000 \times 1,760 \times 3}{240} = \frac{4,092,000}{1}$$

part of a second out of phase, this being the difference between the applied D.C. fluctuation (it being borne in mind that H.F. is rectified by crystal to D.C.), which, when the transformer and loud-speaker impedances fail to handle frequencies above 10,000 per second, and considering their reservoir action would render them negligible.

If he had suggested loose-coupling the aeriols to one inductance I could understand, for the H.F. would then be distinctly out of phase.

Mr. Goldstein makes the apparent mistake of confusing the H.F. portion with the D.C.

Yours faithfully,
R. JONES.

Stoke-on-Trent.

The Editor, POPULAR WIRELESS.

Dear Sir,—It was with great interest that I read the letter from Mr. S. Goldstein in your issue of October 29th, dealing with the Crystal Loud-Speaker Circuit which I suggested in a recent number of POPULAR WIRELESS. The diagram accompanying his letter shows my proposal exactly.

Mr. Goldstein argues that on theoretical grounds the proposal is unsound, but he makes several mistakes which I may be allowed to point out.

1. The distance between the first and the last of eight aeriols spaced 30 ft. apart is not 240 ft., as he states, but 210 ft.

2. As wireless waves travel at the speed of light, namely 180,000 miles per second, the time taken for a wave to travel this 210 ft. is less than one four-millionth of a second. Now, this time interval Mr. Goldstein describes as comparatively large, whereas it is, in reality, so small as to be negligible, for the time taken by one vibration of the highest musical note is over a thousand times greater.

3. Your correspondent overlooks the fact that the current in the loud speaker mains is rectified, and not alternating, as he shows it in his small diagram. That is to say, in each half-cycle of audio-frequency the currents in the transformer secondaries are unidirectional, hence there can be no question of their being out of phase, since their effect is cumulative.

4. Even assuming this out-of-phase effect to take place, all that would be necessary to overcome it would be to arrange all the aeriols pointing towards the station it is wished to receive. The waves will then strike each of the eight terminals simultaneously.

In conclusion, let us view the circuit from another standpoint. Each of the units, if moderately efficient, should be capable of operating six pairs of headphones, and our system as a whole has therefore sufficient power to cause 96 diaphragms to vibrate at head-phone strength. Surely it is not too much to suggest that if combined this power could vibrate one diaphragm at loud-speaker strength.

I hope that some of your readers will try the experiment and let us know the result.

Yours faithfully,
B. WEBB.

Southampton.

The Editor, POPULAR WIRELESS.

Sir,—In the issue of "P.W." dated October 29th, you published a letter from Mr. S. Goldstein, re the Crystal Loud-speaker Circuit.

He mentions the fact that a wave travelling in the direction of the aeriols would hit each one in turn and they would thus be out of phase, but in this statement he has, I think, forgotten the fact that ordinary everyday transmission is broadcast, i.e. the waves are moving in all directions.

In other words, his objection would only apply to beam transmission, and even then the aeriols would have to be absolutely in line with the transmitting station.

Wishing "P.W." every success.

Yours faithfully,
H. V. SMALL.

London, E.C.1.

THE FILADYNE.

The Editor, POPULAR WIRELESS.

Dear Sir,—As the one-valve Filadyne has again been mentioned in your paper, the results of my set may be of interest to yourself and others. It is only a "hook-up," but extraordinary results occur from it.

The loud speaker is quite audible here, 40 miles from 2 L.O., but is best from 5 G.B. Signals are almost the same with the aerial and earth reversed; good signals are obtainable using only 1½ volts (one and a half) on the H.T. (on 'phones, of course); grid bias from the accumulator.

The peculiar fact of the set is that only one valve out of ten tested gives this result. The best valve is a B.T.H. B3 semi-dull-emitter type; other valves bought the same time, same type, refuse to oscillate, and all my others do the same—that is, refuse to oscillate, although fair signals are obtainable on some. Can anyone say why? All I know of these circuits is what I have learnt in POPULAR WIRELESS.

Does anyone know how to make any similar valve oscillate? I have tried everything I could think of, but get no results.

CORRESPONDENCE.

THE CRYSTAL LOUD-SPEAKER CIRCUIT

RECEIVING 2 X A F—
CONCERNING 5 G B.

Letters from readers discussing interesting and topical wireless events, or recording unusual experiences, are always welcomed; but it must be clearly understood that the publication of such does in no way indicate that we associate ourselves with the views expressed by our correspondents, and we cannot accept any responsibility for information given.—Editor.

Everyone who has heard the set has been amazed to hear such results. It is simply splendid in its results if you get the right valve.

I am looking forward to some more information about this circuit from "P.W.," and hope to hear how others have found it.

Thanking you for the instructive and interesting matter in your paper, and wishing you all success.

Yours faithfully,
R. G.

Essex.

RECEIVING 2 X A F.

The Editor, POPULAR WIRELESS.

Dear Sirs,—Referring to letters from "Inquisitive" and Mr. John V. Bolster, regarding the reception of 2 X A F without an aerial, surely these gentlemen do not think they are receiving this station without an aerial merely by "removing the aerial lead." The "jumping" (putting it simply) properties of these ultra-short waves is well known, and the real tests of receiving without an aerial are to take the receiving set entirely away from the aerial, or lower the aerial to the ground. If the latter tests are carried out, I doubt whether Mr. Bolster will receive 2 X A F at such strength as to "hear every word all over the room."

Yours faithfully,
R. C.

E.S.

IS H.F. WORTH WHILE?

The Editor, POPULAR WIRELESS.

Dear Sir,—Regarding your correspondent's very interesting article and lay-out on page 298, October 8th last—all genuine experimenters of long experience will agree this is a very fine little job, but your correspondent hails from Bedford, and gives his side of the tale only. Bedford is generally accepted as being a good corner for reception, but bring this set to London and results would be far from as good!

I enclose you a rough sketch which, in my opinion, is a great improvement, as you will see that I have put the earth terminal where it should be to get the maximum efficiency, and in the place of one aerial terminal I put two, which enables the circuit to be

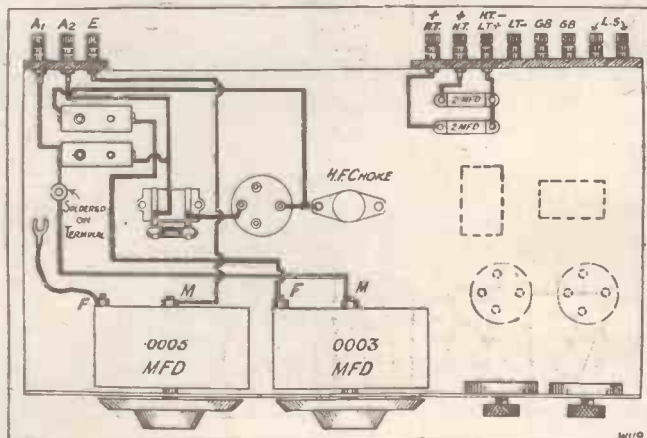

used on all wave-lengths in London and anything on the loud-speaker can be had most pleasingly from (200-500-3,000) with the use of five coils only.

I entirely disagree with the plug-in switching, as if the best results are to be obtained all three must be used at all times, and there is no need for quibble as to consumption of juice, as if 4-volt valves are used. Of the '06 variety, one can use his set for three weeks with one charge for 6d.—that is 2d. a week.

This circuit will get all that can be got pleasurable with a five-valve set requiring a mechanic to operate.

Yours faithfully,
"IS H.F. A LUXURY?"

Forest Gate, E.7.

CONCERNING 5 G B.

The Editor, POPULAR WIRELESS.

Dear Sir,—Having regard to the various complaints re Daventry Junior, it may perhaps interest your readers to hear how that station is received in the extreme east of Switzerland.

First of all, I would point out that this town is situated at an altitude of 5,200 feet above sea level, completely surrounded with very high mountains, and that wireless reception is rather difficult owing to screening and violent atmospheres.

Using a straight circuit, H.F., Det., 2. L.F., with none of the modern improvements such as screened coils, etc., Daventry Junior comes through at full loud-speaker strength, about ten times louder than the local station, Zurich. As for selectivity, a touch of the vernier either way brings in Berlin 483.9 metres or Vienna 517.2 metres.

With regard to Mr. H. I. Knowler's suggestion that the B.B.C. engineers should take lessons from the continent, having lived in the centre of European broadcasting for the past seven years, I think I am in a position to say that the B.B.C. have nothing to learn from the Continent, and that the quality of their transmissions is second to none.

I would suggest that the reply to the "grousters" re Daventry Junior should be, "Look to your sets or the handling of your sets."

Yours faithfully,
P. G. SUTTON, M.S.R.

The X-Ray Institute, Villa Richmond,
Davos-Platz, Switzerland.

The Editor, POPULAR WIRELESS.

Dear Sir,—When 5 G B started to broadcast, I understood that we were to have alternate programmes with no talks from 5 G B. Well, we are certainly getting no talks, the B.B.C. choose to call them "Readings," which last anything up to twenty minutes. To-night, without any warning, we were switched off from a musical programme to a debate, the alternative being News Bulletin and a talk from 5 X X. I think it is time something was done to stop the B.B.C. from departing from their original promises. I know we shall never all be satisfied, but give us a real alternative and I think the majority will be suited.

Yours truly,
"ALTERNATIVE."

Small Heath,
Birmingham.

The Editor, POPULAR WIRELESS.

Dear Sir,—perhaps it will be of interest to you to have particulars of reception on a crystal set at the address given.

Favoured with a good aerial and earth, reception of 5 N O (Newcastle), transmitter about one mile distant, has always been exceedingly strong.

In February, 1925, all the B.B.C. main stations were received quite clearly, with the exception of 5 I T.

Chelmsford and then Daventry have been received since the commencement of transmission.

Reception of the following has been made SEVERAL TIMES during the past few weeks:

Daventry (5 X X), Hiltversum, Koenigs-wusterhausen, Motala, Kalundborg: Any time, Newcastle on or off.

Daventry (5 G B), Hamburg, Frankfurt, Langenberg, Vienna: After 11 p.m. Newcastle closed down.

Radio-Paris: On Sundays, between noon and 1.30 p.m.

Yours faithfully,
W. EDMUNDSON.

(Jesmond—
Newcastle/Tyne.)

A "P.W." PEER.

The Editor,
POPULAR WIRELESS.

Dear Sir,—After giving "three hearty rousers" as requested, it has since dawned on me that I am a "P.W. Peer," and have been cheering myself, so to speak.

A year or two ago, Mr. G. Marcus designed a short-wave set, details of which appeared in your journal.

I built it, and have since coupled a two-valve amplifier to it. The results are really worth "bragging about."

I have received 2 M E (2 F C) four or five times—

once fairly well on the L.S.—2 X A F, and sometimes K D K A nightly on the L.S., and 2 X A D. In addition, I have logged scores of English amateurs as well as Dutch, Belgian, French, and Italian—all on telephony.

Having "blown my own trumpet" till I am exhausted, I will end by wishing your enterprising and interesting journal the success it deserves.

Yours faithfully,
R. G.

P.S.—In these days of "hoaxes" I am willing to sign an affidavit if desired.
London, N.1.



Experience tells

The Igranic organisation has had years of specialised practice in the design and manufacture of current controlling resistances of all types and sizes, from sewing machine control up to those used for the electrical control of huge swing bridges and cranes. Consequently, its products make that near approach to perfection which only wide experience can attain.

Igranic Filament Rheostats embody the result of this experience and have a reputation for reliability and silence of operation second to none. There is an Igranic Filament Rheostat for every purpose and every pocket.

Send for List No. R.68, which gives full particulars of these and other Igranic Radio Devices.

Igranic components are always stocked by reputable dealers. All reports received by us of difficulty in obtaining them receive immediate attention.



Igranic - Pacnet Porcelain Rheostat.
2, 6, 10, 20, 30 and 50 ohms.
Price 2/6

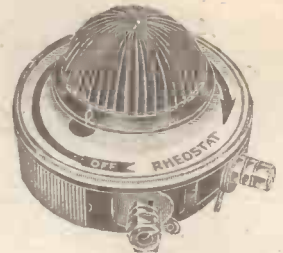

Igranic - Pacnet Bakelite Rheostat.
6, 10, 20, 30 and 50 ohms.
Price 4/-



Igranic-Pacnet Pre-Set Resistor.
For baseboard mounting, 2, 6, 10, 20, 30 and 50 ohms.
Price 1/8

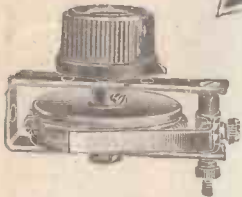

Igranic Filament Rheostat. The original Igranic Rheostat, 4, 6, 8 and 10 ohms. Price 2/- with Knob and Pointer. Price 2/3 with Knob and Dial.

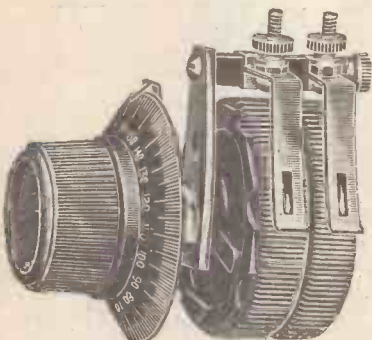

Igranic Universal Rheostat. Each type gives three different resistances. Model A—4, 8 or 10 ohms. Model B—7, 15 or 30 ohms. Price 4/- with Knob and Pointer. Price 4/6 with Knob and Dial.

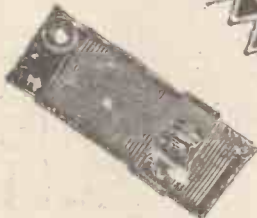

Igranic Auxiliary Rheostat. For increasing value of existing rheostats. Resistance - 25 ohms. Price 1/-



149, Queen Victoria Street, LONDON, E.C.4.

Works: BEDFORD.

Branches—Birmingham, Bristol, Cardiff, Glasgow, Leeds, Manchester, Newcastle-on-Tyne.

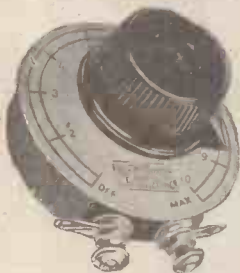

C.E. PRECISION H.F. CHOKE
Has a minimum self capacity and a small external field. Covers a wide range of wave-lengths. Price 7/- . A Short Wave model is available at the same price.

Write for full list of components and circuit diagram of the "ORCHESTRAL THREE," the Receiver that Sets the Standard of Perfection.
C. EDE & CO., LTD., BYFLEET, SURREY.

Phone: Byfleet 226.
Grams: Cephreclse, Byfleet.

C.E. PRECISION RHEOSTAT.
A beautiful little component: the smoothness of its control is remarkable. Prices from 2/9 to 3/9.

TWO WONDERFUL LOUD SPEAKER SETS

These wonderful instruments incorporate all 1928 improvements, and are the finest sets money can buy.

22 STATIONS on the two-valve and 46 STATIONS on the three-valve have actually been received, and most of these at good volume on the loud speaker.

The latest all-wave tuner is used, thus eliminating coils entirely, and any amateur can build these sets in two hours.

NO SOLDERING — NO DRILLING — NO COILS TO CHANGE.

Booklet describing the "Saxon" Two-Valve Loud Speaker Set, with diagram and full instructions. 3d. post free.

Booklet describing the "Saxon" Three-Valve Loud Speaker Set, with diagram and full instructions. 3d. post free.

SAXON RADIO CO. (Dept. 14), HENRY ST. WORKS, BLACKPOOL



Traders and manufacturers are invited to submit wireless sets and components to the "P.W." Technical Department for test. All tests are carried out with strict impartiality in the "P.W." test-room, under the supervision of the Technical Editor, and the general reader is asked to note that this weekly article is also intended to provide a reliable and unbiased guide as to what to buy and what to avoid.—EDITOR.

IGRANIC TAPPED COILS.

IT seems rather curious that until recently the Igranic Company have not had a range of tapped coils on the market, inasmuch as they were pioneers in regard to plug-in coils for radio sets. Tapped coils are very widely used these days, and even in older sets the ordinary plain varieties are being dispensed with, especially in the aerial position, and tapped coils introduced to give the necessary selectivity for separating 5 G B and the local station.

However, the new Igranic range of tapped coils is most comprehensive, and the coils are attractive and compact in general design. There are five types in the range, and each embodies two tappings.

Each coil is wound in the familiar honey-comb Duolateral manner and its windings arranged in three sections. On the base are two sockets, one each side. One is coloured green and the other red. These

sockets take ordinary wander plugs, and constitute an ingenious and convenient method of making tapping connections. This Igranic tapped coil has a much neater appearance than many tapped coils, and occupies no more space than the ordinary Igranic Plug-in type. On test we found every one in the range to be perfectly satisfactory. Used in aerial positions, sufficient selectivity was obtained to separate 5 G B from Langenberg. This was on a detector and one L.F. set, with single-coil tuning—a receiver which in the ordinary way brings in both those stations fairly badly mixed.

GECOPHONE FILAMENT RHEOSTAT.

The G.E.C. people recently sent us samples of their new plunger type filament rheostats for baseboard and panel mounting. In each type there are three models, having resistances of 6, 12, and 30 ohms,

the price of any one of these being 2s. 9d. They are very neat, compact, and well-made components, the plunger actions being smooth and positive. In each the resistance wire is wound round a slider strip which is arranged on the inner side of a circular insulating casing, which carries the two terminals.

To a central spindle is fixed a large milled knob for adjustment purposes, and an arm bearing a spring plunger. Because the filament rheostat is mounted behind the panel of a baseboard, there is no reason why it should be a rough and unattractive device. That it should operate efficiently is a necessity, and constructors will welcome a component of this nature which is up to standard in all these respects and which sells at the above-mentioned reasonable price.

LEWCOS RADIO PRODUCTS.

The London Electric Wire Co. & Smiths, Ltd., inform us that the demand for their "Lewcos" radio products has been so enormous that it has quite outstripped their manufacturing programme. There is, in consequence, a delay in delivering certain lines, but they are increasing their production daily, installing additional manufacturing and testing plant, and will very shortly be in a position to meet all demands.

RADIO DIRECTION FINDING.

His Majesty's Stationery Office has published a report summarising the progress made in the investigations on radio-direction finding, and particularly "night effects," carried out under the auspices of the Directional Wireless Committee of the Radio

(Continued on page 672.)

CLARKE'S
"ATLAS"
NEUTROFOUR

Simplicity itself, both to build and to operate, the Neutrofour gives a new meaning to the old phrase "distance no object."

A dozen stations on the loud speaker, within two miles of a B.B.C. main station; a range that is world-wide; razor-keen tuning; perfect purity—and no trace of re-radiation.

SEND FOR FREE 20-PAGE NEUTROFOUR BOOKLET AND BLUEPRINT.

H. CLARKE & CO. (M/c.) LTD.,
ATLAS WORKS, OLD TRAFFORD,
MANCHESTER



SELFRIDGE'S

LONDON'S RADIO HEADQUARTERS

SELFRIDGE'S Great New Services for Radio Enthusiasts have met with a wonderful success, and many thousands have already expressed their unbounded delight and appreciation at this great advance in Radio Facilities. Why not take advantage yourself of these wonderful new services?

THE WONDERFUL NEW SERVICES

No. 1. SELFRIDGE'S NEW WIGMORE STREET RADIO ANNEXE

There are still many of our friends who are unable to visit us during usual business hours, and for their convenience our Radio Annexe at 101 Wigmore Street (corner of Duke Street), will remain open daily until 7 p.m. (except Saturdays, of course).

Here will always be found a full stock of all the latest components and a number of very special money-saving bargains.

No. 2. COMPLETE SETS OF COMPONENTS ON DEFERRED PAYMENTS

We have long felt that so many more would be able to enjoy building the new circuits which appear from time to time were it not for the big original outlay. We have much pleasure, therefore, in announcing that Sets of Components may now be obtained from Selfridge's at once—payment to be spread over six months (5 per cent. only being added to the total value), minimum total cost, £3.

Satisfaction is assured with the famous "CLEARTRON" VALVES

If you will tell us what Valves you are using to-day, we will advise you the type of "Cleartron" Valve you should use in its place. Fresh supplies are sent daily from the factory at Birmingham.

GENERAL PURPOSE VALVES, SELFRIDGE'S **3/9** BRITISH POWER AND R.C.C. AMPLIFICATION VALVES, SELFRIDGE'S **6/6**

Standard Price, 10s. 6d. (Postage 3d. extra) Standard Price 12s. 6d. (Postage 3d. extra.)

Post free on Orders over 10s.

Valve.	Filament Volts.	Filament Amps.	Impedance Ohms.	Amplification Factors.
CT08 ..	3.0	0.08	18,000	7.5
CT08* ..	3.0	0.15	8,000	4
CT10 ..	3.8	0.1	15,000	7.5
CT10* ..	3.8	0.1	8,000	3.8
CT15 ..	1.8-2.0	0.15	18,000	7.5
CT15* ..	2.0	0.3	5,000	3.5
CT215H†	2.0	0.15	100,000	4.5
CT25 ..	5.0	0.25	10,000	9
CT25B† ..	5.0	0.25	20,000	20
CT25* ..	5.0	0.5	4,000	5

Power Valves are marked *

Valves marked † are Special Valves for resistance capacity amplification.

SPECIAL BARGAINS

The renowned Polar Junior Condenser, very low capacity, long straight line frequency scale, compact and perfectly screened. In Black Japan finish with knob and dial, capacities '0005, '0003 and '001 only.

Selfridge's Price **2/-** Postage 3d. extra.

RADIO DEPT. 1st FLOOR.

STEADY PERSISTENT SERVICE

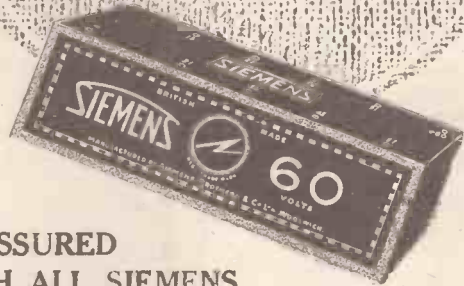

IS ASSURED WITH ALL SIEMENS BATTERIES

THEY are British-made throughout at Woolwich works, and with the practical experience of over 50 years' dry battery manufacture behind them they represent the best value on the market to-day.

60 volts (as illustrated) 9/6
100 volts 15/6

FOR POWER VALVES USE A POWER BATTERY and ensure that clear reception, long life and complete satisfaction which a SIEMENS POWER BATTERY WILL GIVE.

"Power" 60 volts ... 17/6
"Power" 100 volts ... 29/-

Ensure that your next Battery will be an exceptionally good one, Specify—

SIEMENS RADIO BATTERIES

SIEMENS BROTHERS & Co., Ltd., WOOLWICH, S.E.18

APPARATUS TESTED.

(Continued from page 670.)

Research Board during the last five years. It contains some very useful information, more particularly in respect to the elimination of night errors. It should prove very interesting to the more advanced amateur. The price of this report is 1s. 9d. net.

A CHOKE COIL FORMER.

Messrs. Redfern's Rubber Works, Ltd., of Hyde, Cheshire, are producing an ebonite former suitable for the winding of high-frequency chokes. A thick slotted pillar is mounted on a small base carrying two terminals. If desired, the base can be discarded—it can be removed by unscrewing a screw—and the two terminals fitted in holes provided in the ends of the former. The choke can then be used with grid-leak clips or suspended on wires. The former is cleanly turned and vertical slots are provided to facilitate winding. Directions are given on the carton for the winding of a choke of average dimensions.

WOOD FOR RADIO PANELS.

There are no objections against the use of any of the hard woods for the panels of radio receivers. A very suitable wood for the purpose is Padauk. It is like a very hard cedar, is close grained, and polishes very nicely. Messrs. W. W. Howard Bros. & Co., Crown Wharf, Canning Town, London, E.16, recently sent us samples of their Burma and Andaman Padauk wood. The latter is much

darker, and would appear to us to be eminently suitable for the indicated purpose.

NEW "RADION" VALVES.

Radions, Ltd., of Bollington, have issued a new range of valves which are styled "Professor Low's Super Valves." Each carton carries the statement that "the design, construction, and testing of this valve have been carefully carried out to meet Professor A. M. Low's requirements for a valve of this class."

The first sample of the series to reach us is a 2-volter taking 15 amps., having an impedance of 18,000 ohms and an amplification factor of 9. These characteristics are marked on the valve itself. A neat transfer in black and gold is fixed on the bulb, and this shows the characteristic curves of the valve for 60, 80, and 100 volts, together with all the usual data. The curves are, of course, small, but are quite readable. It is an excellent scheme.

The valve more or less falls under the

"General Purposes" heading, and can be used in certain high-frequency positions, as a detector and as a "first-stage" low-frequency amplifier; and it gives quite good results. We particularly like it as a detector in a leaky-grid rectifying stage, in which it functions very well. It was designed primarily for low-frequency work.



A broadcast in progress from P C J J, the well-known Dutch short-waver. Mr. Faraker, representing Australia's High Commissioner, is reading a message from his chief.

SENSATIONAL

IMPROVEMENTS IN AERIALS
AMAZING SUCCESS OF GÖLTONE NEGROLAC

EXTRACTS FROM TECHNICAL REPORTS AND LETTERS RECEIVED.

"WIRELESS CONSTRUCTOR" (Nov., 1927): "NEGROLAC (Regd.) Aerial gave better results than any aerial previously tested."

"RADIDEA," of "MANCHESTER EVENING CHRONICLE," reports 25 per cent. gain in receptivity using NEGROLAC Aerial.

Mr. A. C. Stanley Park Road, Wallington, writes: "5GB came in 25 per cent. stronger on NEGROLAC Aerial, detuning being necessary to avoid overloading power valve. Distant reception improved beyond measure."

FEATURES OF NEGROLAC (REGD.) AERIAL. 49 strands, each enamelled and specially stranded. Fabric outer covering NEGROLAC varnished, ensuring high insulation, minimum surface leakage, long life, and maximum efficiency. 50 ft. lengths, 9/-; 80 ft. lengths, 15/-; 100 ft. lengths, 18/-.

From all leading Stores. Refuse substitutes. Write for descriptive leaflet giving full particulars and results.

Ward & Goldstone
SHEFFIELD & MANCHESTER, ENGL.



FORMO
REGISTERED TRADE MARK

A MONUMENT IN THE MARCH OF PROGRESS.

The Formo Shrouded Transformer is the universal favourite.

10/6 Made in Ratios, 1-1, 1-2, 1-3, 1-4 and 1-5. 1-3 and 1-5 for First and Second Stages

SEND FOR CATALOGUE AND DESCRIPTIVE LITERATURE OF COMPLETE FORMO RANGE.

THE FORMO COMPANY,
CROWN WORKS, CRICKLEWOOD,
N.W.2. Phone: Hamb. 1787.



A Sound Investment

THE NEW MOVING COIL LOUD-SPEAKER. All parts to make up this marvellous sound reproducer now in stock.

GET READY FOR THE CHRISTMAS PARTY by electrifying your Gramophone. All makes of pick-ups now in stock. Igranio 35/-, Burne Jones 35/-, Brown £4, etc., etc.

What about a new Receiving Set for Christmas either as a present for a friend or for your own use at home? Two, three, four or five valve MARCONI SETS SUPPLIED ON THE HIRE PURCHASE SYSTEM. Write in for leaflet giving all particulars and secure one of these most efficient sets before the holidays.

An ideal Xmas present. Only a few left. AMPLIFEX LOOP AERIALS. The most efficient loop yet devised. To clear 30/-

Our new Catalogue is now ready. Send to-day for your copy—66 pages profusely illustrated with all the latest wireless components. Price 6d. to defray postage and packing. CALLERS FREE.

WILL DAY, LTD.

(The Best in the West)

19 Lisle Street, Leicester Square, London, W.C.2

Telephone: Regent 4577 Telegrams: Titles, Westrand, London.



If you want
Real Selectivity

TRY THESE
**SCREENED
RECEIVERS**

So remarkable is the selectivity of this set that, working within 10 miles of 2 L.O., stations within 20 metres of the London wave-length can be tuned in without interference.

There is a Magnum Screened Three, Four and Five, and all are well tried and proved circuits combining exceptional purity of reproduction with this fine selectivity. You can build any of these sets or buy them complete, and the cost is surprisingly small.

Send a 1½d. stamp for literature and instructions for building.

**MAGNUM SCREENED THREE,
FOUR AND FIVE.**

PRICES:

Screened Three £10 15 0
Screened Four £12 15 0
Screened Five £15 10 0

Plus Marconi Royalties.

**BURNE-JONES
& CO. LTD.,
MAGNUM HOUSE
TELEPHONE: HOP 6257
288, BOROUGH HIGH ST.
LONDON. S.E.1**



You can
buy it
for "a
round
£3."

and it

looms large to-day

this speaker that makes a poor set good and a good set better—the

ETHOVOX

For a time radio-listeners have been fascinated by loud-speakers of weird and wonderful construction but, to-day, they're coming back in ever-increasing numbers to the speaker that first made wireless popular.

And it's as superior to-day as it was then, as certain to enhance a hundred-fold your pleasure and enjoyment.

It is cheaper too—not cheapened mark you—and "a round £3" will buy it!

If you'd like to hear it "speak" before you buy, write us and we'll arrange for you to do so—ask at same time for latest descriptive folder.

BURNDIPT,

**Blackheath :: London, S.E.3
Showrooms: 15, Bedford St., Strand, London**

RADIOTORIAL

All Editorial Communications to be addressed to The Editor, POPULAR WIRELESS, The Fleetway House, Farringdon Street, London, E.C.4.

The Editor will be pleased to consider articles and photographs dealing with all subjects appertaining to wireless work. The Editor cannot accept responsibility for manuscripts and photos. Every care will be taken to return MSS. not accepted for publication. A stamped and addressed envelope must be sent with every article. All inquiries concerning advertising rates, etc., to be addressed to the Sole Agents, Messrs. John H. Lile, Ltd., 4, Ludgate Circus, London, E.C.4.

The constructional articles which appear from time to time in this journal are the outcome of research and experimental work, carried out with a view to improving the technique of wireless receivers. As much of the information given in the columns of this paper concerns the most recent developments in the radio world, some of the arrangements and specialities described may be the subject of Letters Patent, and the amateur and the trader would be well advised to obtain permission of the patentees to use the patents before doing so.

QUESTIONS AND ANSWERS.

DRIVING WOOD-SCREWS INTO EBONITE.

"EBONITE" (Fakenham).—"When building up a wireless set from POPULAR WIRELESS or other printed instructions, the constructor

is frequently told to drive a wood-screw into ebonite. Personally, I am never able to do this, unless by sheer good luck, without either the head of the screw splitting, or else the point of the wood-screw becoming embedded in the ebonite and breaking off. What is the proper method?"

It is necessary to drill a hole almost as big as the wood-screw to be used, and practically the same depth, so that the screw itself does not cut into any solid ebonite. A hole of the correct size allows just the thread of the wood-screw to cut a groove in the ebonite, and thus the wood-screw can be driven in or withdrawn. But the size of drill chosen should be such that the body of the screw itself lies in the hole prepared for it, and does not have to drive into solid ebonite, as it would into solid wood. (The wood-screw will hold with perfect rigidity in ebonite, even though the latter has only been cut laterally by the thread, as the screw is driven home.)

As the screw has to cut its own thread through the ebonite, the screwdriver must only be turned, say, a quarter of a turn, at a time. It must then be turned backwards and the same distance forwards again, half-a-dozen times in succession, in order that the thread may cut into the ebonite. When the screw turns easily in this way it may be advanced another quarter of a turn, and then worked backwards and forwards again until in this position also it turns easily. By drilling the hole the right depth and size, and then driving the screw very slowly,

a little at a time, it will be found that there is no tendency for the head of the screw to break off for the point of the screw to break off.

GRID RESISTANCE FOR VOLUME CONTROL.

"VARIO" (Bristol).—"What sort of resistance should be used in the first valve's grid circuit to act as a volume control?"

Such a resistance should be non-inductive, and the value should be adjustable up to 400 or 500 ohms.

STICKING PANEL LABELS.

S. R. (Fenton, Staffs).—"Can you tell me how to fix the little ivory labels back on the panel? Two of them have come unstuck, and the others begin to look a bit groggy, so unless I can fix them back there is a danger of somebody connecting up the leads wrongly some day."

Ordinary rubber solution as used for repairing punctures in bicycle tyres will generally make a good job of this kind of loose label. Spread a thin coating on both panel and label, and when thoroughly tacky place the label in position and press down with a weight for an hour or so.

KEEPING THE WIRING CLEAN.

"KON-STRUCTOR" (Tring).—"Try as I will, I can never keep the back of the panel free from blobs and smears of flux. How do the professionals manage to wire up so neatly? Is the secret in the flux used?"

No; the "secret" is an ordinary common old duster or piece of cloth—used at the correct time. It is no good trying to remove flux after it has cooled down, so the correct procedure is to use as little as possible, and wipe it off with the duster whilst the metal joint is still hot.

At this stage the flux is in a liquid state, but if the wiping is not done immediately the flux rapidly cools, gets sticky, and becomes a permanent nuisance. Try wiping over every joint the moment that it is made. You will be surprised how easy it is to remember, and how much this simple precaution improves the appearance of the completed wiring.

(Continued on page 676.)

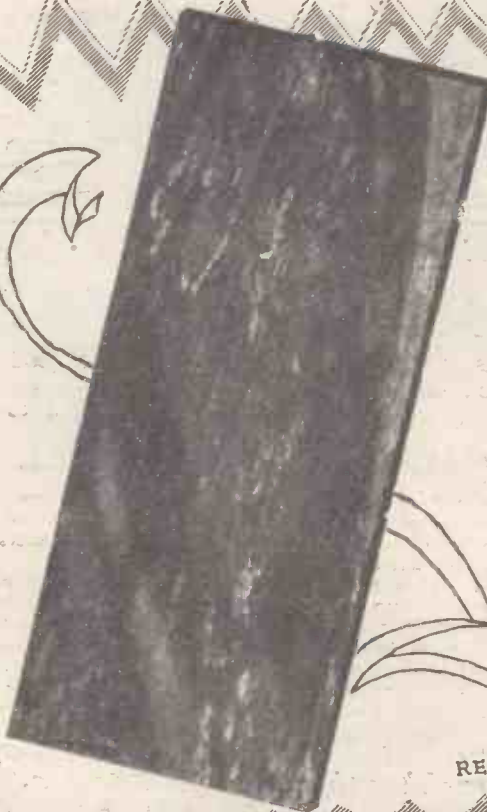

COLOUR PERMANENCE—
vital to the beauty of your set

EBONART PANELS
RETAIN THEIR COLOUR AND
BRILLIANCE INDEFINITELY

The sealing of the structure of
Ebonart by Redfern's exclusive
process ensures this for you

MAHOGANY GRAIN AND BLACK IN
ALL STANDARD SIZES

REDFERN'S
Ebonart
NON-METALLIC SUBSTRATE EBONITE
RADIO PANELS

Your Dealer can supply you
REDFERN'S RUBBER WORKS LIMITED HYDE, CHESHIRE



Tested on 500 volts D.C., or if you wish to pay a few shillings more, Tested on 750 volts D.C., it offers you the best value for money ever given in Wireless. And . . . there never was a more dependable condenser.



Prices : Tested on 500 volts D.C.
1 mfd. - 2/6 2 mfd. - 3/6 4 mfd. - 5/3
Prices : Tested on 750 volts D.C. equal to
500 volts A.C.
1 mfd. - 3/- 2 mfd. - 4/- 4 mfd. - 6/9

From all good dealers or direct—

LOUIS HOLZMAN
34, Kingsway, London, W.C.2.
Telephone: Holborn 6204.

HEAD NOISES
CURED WITH FLUXITE
it simplifies soldering

All Hardware and Ironmongery Stores sell FLUXITE in tins, price 8d., 1/4 and 2/8.
Another use for Fluxite—Hardening Tools and Case Hardening. Ask for leaflet on improved methods.

FLUXITE Soldering Set—Complete 7/6

FLUXITE, LTD.
(Dept. 324),
Rotherhithe, S.E.15.

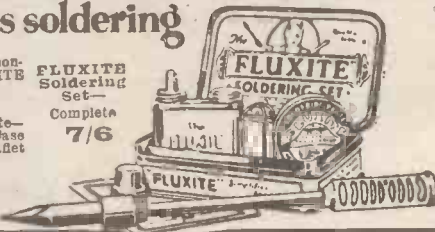

MAKE YOUR OWN CONE SPEAKER

TWO WONDERFUL UNITS AT ONLY **15/-** EACH
YOU'LL BE SURPRISED!

The New Wonder "Nightingale" **GRAMOPHONE CONE UNIT ATTACHMENT**
with Balanced Armature.



AS FITTED TO OUR CABINET CONE

with 4-inch dia- phragm.

AS FITTED TO OUR £6 POST HORN.

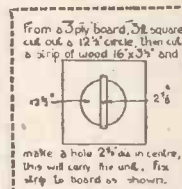

BULLPHONE DOUBLE PAPER CONE 2/-
Postage 5d extra

Exactly as fitted to our own Speakers.

Reduced from 32/6 to 15/- solely as an advertisement for the famous Bullphone Nightingale Loud Speakers. Cobalt Magnet guaranteed for all time.
Astonishing Results, equal to the most expensive Loud Speakers yet made, are guaranteed with either of these Units.

BUY ON 10/- EASY TERMS 5/- DEPOSIT



CABINET CONE

Size 17 ins. high by 15 ins. in Mahogany, Walnut or Rosewood finish.

77/6 cash, or **EASY TERMS** 10/- deposit and 12 monthly payments of 6/-

SEND DEPOSIT NOW—NO REFERENCES—SPEAKER BY RETURN.



DE LUXE

21 ins. high, with 14-inch Bell, Mahogany finished, with plated arm and stand.

57/6 cash, or 5/- deposit and 12 monthly payments of 5/-

SATISFACTION GUARANTEED OR MONEY REFUNDED.

Obtainable from your Local Dealer or direct from—



No more BURNT OUT VALVES

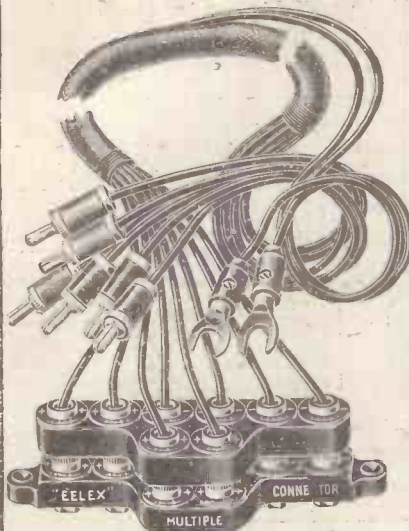

(Illustration half size)

if you use an



MULTIPLE CONNECTOR

The EELEX Multiple Connector supercedes loose wires and switches, etc., and when disconnected automatically switches off aerial, earth, H.T., L.T., G.B., etc. Non-reversible, interchangeable nameplates, all parts are standard EELEX fittings. Price 5/6 each (coloured flex to match tabs 1½d. per yard). Write for List T. 24.



TREBLE-DUTY TERMINALS

Terminal T2LC
with indicating top, nickel plated finish.
4½d. each.

T2LN
with plain top, nickel plated.
3d. each.

AFRIAL

REACT

PHONES

OUTPUT

OUTPUT

L.T.

L.T.

INPUT

INPUT

H.T.

H.T.

Of exceptional value to the wireless constructor, as they provide facilities for connecting securely—spade, plugs, pin tag or loose wires—and being slotted, internal joints need not be soldered.

J. J. EASTICK & SONS,
Eelex House,
118, Bunhill Row, Chiswell St., E.C.1.

RADIOTORIAL QUESTIONS AND ANSWERS

(Continued from page 674.)

CRYSTAL OR VALVE FOR PURITY?

C. J. W. (Cardiff).—"Will you settle an argument for us? My friend says that a crystal detector *does* distort the received music to some extent, but I say No. He admits he has never heard any noticeable distortion on a crystal set, but he won't admit that the crystal is a perfect rectifier. It is, isn't it?"

No, C. J. W., the crystal is not a *perfect* rectifier. Theoretically it can be shown that the current passing through an ordinary crystal detector does not vary in exact accordance with the voltage variations; in other words, there is unequal response, which means distortion.

This, of course, is very slight and relatively unimportant; but, nevertheless, it is there, so your friend is quite right.

(The subject of distortion caused by the various forms of detector was dealt with clearly and interestingly by Captain Eckerley in the May number of "Modern Wireless." The title of the article was "The Search for Quality.")

HOW WIRELESS CURRENTS FLOW.

W. B. (Mansfield, Notts).—"I have been reading with great interest your series for the new amateur now appearing in POPULAR

WHAT IS WRONG?

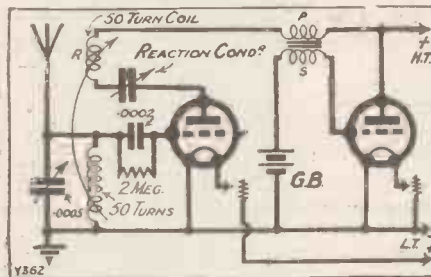

The above diagram is supposed to represent the connections of a detector and low-frequency set with condenser-controlled reaction. But it is wrong, and the set would not work.

Next week the correct diagram will be given, and to test your skill we shall continue to publish every week a diagram in which a mistake (or mistakes) has been inserted. The correction will be published the following week, and the series will work up from a simple crystal set to multi-valvers.

No prizes are offered, but by following this series and trying to solve the problems week by week the reader cannot fail to learn a lot about radio circuits.

WIRELESS. One point in the second article of the series rather confused me. Looking at Fig. 5 it seems to me that the oscillating current has two paths from aerial to earth. The first is a direct route by way of the coil, whilst the second is a route in which it will have to have a number of jumps from plate to plate of the variable condenser. Why does not the current take the path of least resistance, ignoring the condenser altogether?"

Your confusion arises from forgetting that the currents we are dealing with are *high-frequency* ones, and high-frequency currents do the most amazing things. Flowing at their high frequency of a million or more times per second, they are in such a hurry to go from aerial to earth and vice versa that they will rather jump across from one plate of the condenser to the next than go toiling round and round a long coil. Ordinary direct current would, of course, flow through the coil, and ignore the condenser altogether. But a high-frequency current changes its direction at such exceedingly short intervals that it finds in its impatience it is just as easy to jump across the plates of a condenser as to take the longer, and apparently better, pathway offered by the many turns of the coil.

(Continued on page 678.)

SFERAVOX Cone Loud Speakers

The Manufacturers of these well-known Cone Loud Speakers (Societe Francaise Radio Electrique) view with regret the actions which have been commenced alleging infringement.

THEY HEREBY GIVE NOTICE

to the trade that they are advised the Loud Speakers manufactured by them and known as "Sferavox" do not infringe any existing valid Patents and they are prepared to defend any action which may be taken against any of their customers in respect thereof and for which purpose a large sum of money has been deposited in England. Any person receiving threat in respect of Sferavox Loud Speakers should communicate at once with the Manufacturers' Solicitors, Messrs. Philip Conwey Thomas & Co., 80, Rochester Row, Westminster, S.W.1.

The Manufacturers offer a full indemnity and beg to inform the trade that they have retained eminent counsel, Expert Patents Agents and Solicitors in order to safeguard the interests of their Customers. [ADVT.]

RADIO BARGAINS 2" Spark Coil, no trembler, 7/6; Mine Exploder Dynamos, 50-v. 5-amps., 20/-; 2 M.F. Condensers, 2/-; 2 Dewar Switches in case, 1/6; Good Microphones, 1/6; Transformer to suit, 2/6; Earphones for pick-ups, 1/6; Buzzers, 1/-; Marconi variable Condensers, 1. 6/-; Large L.F. Transformers, 6/-; 1" Spark Coils, 5/-; Good Fan Motors, large, 110 and 220-v., 10/-; 1,000 Chokes, 1/-; 3 H.P. Motors, 100-v. D.C. and Starter, 40/-; 5 Condensers, H.T., 1/6; Skindewken Microphone Buttons, 2/-; 30 feet Lead-in Wire, 1/-; 6 Cylinder Dixie Magnets, new, 50/-; Tuning Inductance in case, 12" x 10", 20 to 5,000 metres, 10/-; Postage extra. Cash with order. Satisfaction guaranteed. Stamp particulars.—GALPIN, Binfield Heath, nr. Henley-on-Thames

D-XELLENT!

DX PLUG-IN COILS

From 1/- DX COILS, LTD., London, E.8.

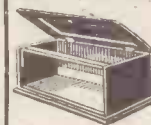

CABINETS OF MERIT

12x7.. 10/6 16x8.. 15/6
14x7.. 12/6 18x7.. 17/6
21x7.. 21/-

List Free Melody Maker .. 25/-
Prompt Delivery. PEKE DISTRIBUTING CO., 25, Lechmere Rd., London, N.W.2

EASY PAYMENTS

LOUD-SPEAKERS, HEADPHONES, H.T. ACCUMULATORS. Anything Wireless Send a list of the parts you are requiring, and we will send you a quotation on monthly payments.
H. W. HOLMES, 29, FOLEY STREET,
Phone Museum 1414. Gt. Portland St., W.1.

COILS FOR COSSOR MELODY MAKER

Wound to Specification. 7/6 each. Immediate Delivery.
The J.R. WIRELESS CO.
6-8, Rosebery Avenue, E.C.1.
Phone: Clerkenwell 9515.

ADVERTISEMENTS

As far as possible all advertisements appearing in "P.W." are subjected to careful scrutiny before publication, but should any reader experience delay or difficulty in getting orders fulfilled or should the goods supplied not be as advertised, information should be sent to the Advertisement Manager, "Popular Wireless," 4, Ludgate Circus, London, E.C.4.



**Worth £5.50
costs only
27/6
to build**
STAND 6'6" EXTRA

**Goodmans Loudspeaker components
have stood the test of time.**

That thousands have found it an easy matter to construct a Loud Speaker capable of wonderfully faithful reproduction, for an exceptionally low cost, is proved by the large number of unsolicited testimonials received. The Goodman Seamless Moulded Cone has established itself as the finest Diaphragm at present obtainable. Our Double-Acting Reed Unit (27/6) is undoubtedly the most sensitive and powerful Unit on the market. The Goodman JUNIOR, a Unit of exceptionally good design, although only recently introduced, is now acknowledged to be far superior to any Unit at near its modest price (14/6); in fact, second only to our Double-Acting Reed type. It is much cheaper to build your own Speaker, with Goodman's parts. It will give you results equal to any on the market, irrespective of price, and will astonish you in its fidelity of reproduction. Avoid Imitations. GOODMAN'S were the pioneers of Specialities for Home Constructed Loud Speakers. Experience counts!

SEAMLESS MOULDED CONES ARE BEST WITH ANY UNIT. ANY CONE IS BETTER FITTED WITH A GOODMAN UNIT.

If you are interested in **COIL-DRIVEN SPEAKERS**, see our Lists (C.D.5) of **COIL SPEAKER UNITS**, etc. Quality and finish are of the usual high GOODMAN standard, and prices as low as possible, consistent with perfect workmanship.

Illustrated descriptive lists on request.

Original unsolicited testimonials at our office:
From **BLACKPOOL**: "The first trial to-day proves the superiority of your Seamless Cone Speaker over all others I have heard at more than three times the price."

From **LIVERPOOL**: "The GOODMAN UNIT handles volume equal to a Moving Coil Speaker without overloading. Startlingly efficient, and all you claim as far as volume, purity and mechanical perfection is concerned."

Easy terms can be arranged if desired.

If you have any difficulty in obtaining locally, send direct to us, enclosing your Dealer's name and address.



The Goodman Junior.

A Reed Unit specially designed for the sole purpose of driving large diaphragms of the Cone, Pleated Disc, or similar type. NOT a converted Earpiece or Gramophone attachment.

Advt. of GOODMAN'S, 27, FARRINGTON ST., LONDON, E.C.4.

Important to Advertisers

Our Issue for DEC. 10 will be a specially enlarged

XMAS NUMBER

with charming cover in full colours.

Large increase in sales.

No increase in Advt. rate.

CUT THIS OUT FOR CABINETS

and post to us for new FREE list illustrating Cabinets as shown in "Popular Wireless," etc., etc.

NAME

ADDRESS



(Write in block letters, please.)
CARRINGTON Mfg. Co., Ltd.,
CAMCO WORKS, SANDERSTEAD ROAD,
SOUTH CROYDON.
Telephone: Croydon 0623 (2 lines).
Trade enquiries especially invited.

Perfect in every way

~in design,
clarity,
sensitiveness
& comfort.
They cost only

15/-

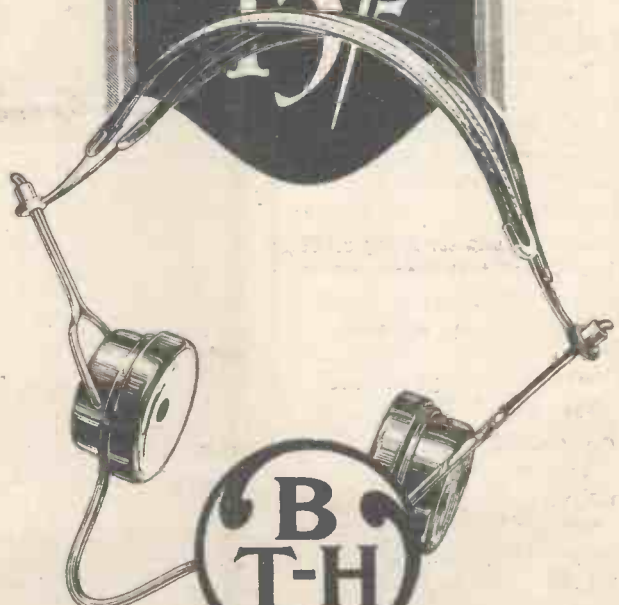

HEADPHONES

The above price is applicable in Gt. Britain and Northern Ireland only.

The British Thomson-Houston Co., Ltd.



**A
PEERLESS
COMPONENT
THE PEERLESS NEUTRODYNE
CONDENSER**

This component is neat in design and robust in construction. Rotation of an ebonite knob causes a circular brass plate to move towards or away from a fixed circular brass plate attached to a disc of insulating material. Contact between the two plates is prevented by means of a thin insulated disc placed between them. The fixed plate is attached to the centre of an insulated washer, the latter being held in position by a neat metal case which encloses the plates. A metal sleeve is attached to the case, and in conjunction with a nut provides a means of fixing the component to the panel after drilling a single hole.

On test the minimum capacity was found to be 3 micro-microfarads, while the maximum capacity was 22 micro-microfarads. This is a satisfactory range of capacities for neutralising all types of receiving valves.

Panel Mounting - - 2/6
Baseboard Mounting - 3/-

**THE BEDFORD ELECTRICAL
AND RADIO CO., LTD.,**
22 Campbell Road, BEDFORD.

LONDON:
21 Bartlett's Buildings,
Holborn Circus, E.C.4.

GLASGOW:
113 St. Vincent Street,
C.2.

**RADIOTORIAL
QUESTIONS AND ANSWERS**

(Continued from page 676.)

CENTRE-TAPPED COILS.

A. V. S. (Stroud Green, London, N.).—"In a centre-tapped coil of 200 turns, as mentioned in "Radiatorial" of POPULAR WIRELESS No. 275, September 10th issue, should the centre tap be taken at the one-hundredth turn, or at the middle of the length of wire? If the latter this will be nearer 120 than 100 turns."

Theoretically, it is better to take the tapping from the inductive centre of the coil. This is not easy to find, but it will be at about the middle of the

A CRYSTAL SET AND L.F. AMPLIFIER.

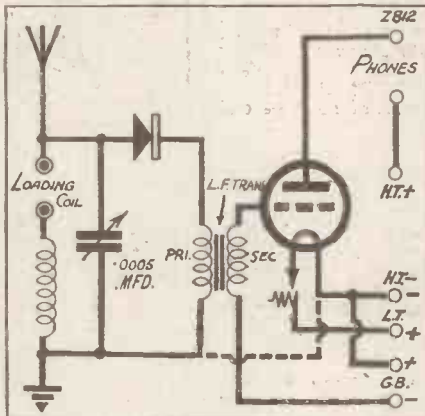

The correct connections for a crystal set and low-frequency amplifier suitable for receiving 5 X X or the local station are shown above.

In the "What is Wrong?" diagram last week the loading coil was connected outside the tuned circuit instead of inside.

(The dotted line joining earth to the H.T. neg. and L.T. neg. terminal indicates that if a separate amplifier is used the batteries should be earthed.)

length of the wire. The position for such a centre-tap, however, is not at all critical, and in practice it is found that any position which is about the centre of the coil will be quite satisfactory.

THE "Q. and A." SET.

"APERIODIC" (Navan).—"In what issue of POPULAR WIRELESS was the 'Q and A' set described?"

This popular two-valve receiver was described in "P.W." No. 241.

**Don't Miss the
SPECIAL XMAS
NUMBER**

**of
MODERN WIRELESS**

containing a
FREE FULL-SIZE BLUE PRINT

**of the
VIKING IV**

Out Dec. 1st. Price 1/6

**A Jewel
AMONG LOUD SPEAKERS**

The "GEM" for purity and price-value is immediately chosen by all possessing a "musical ear" and an "eye" for value.

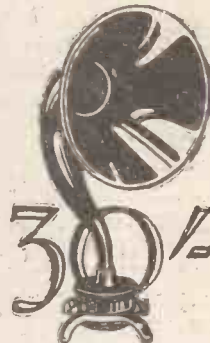

**THE
"GEM"**

Height, 19 in.

Flare, 10 in.

Resistance
2,000 ohms

A CHOICE XMAS GIFT—THE "GEM"

It is not a "Baby" or a "Junior," but a full-sized loud speaker which gives splendid reproduction with ample volume.

The "GEM" has a base mechanism of generous construction, and is built to handle good volume without the slightest distortion.

PRICE **30/-** FULLY GUARANTEED

STOCKED BY ALL DEALERS

who will freely demonstrate the splendid qualities of the "GEM" and other models manufactured by

LONDON RADIO MFG. CO., LTD.
Station Road, Merton Abbey, London, S.W.19

RADIO REGISTERED PANELS

7x 6, 1/3	9x 6 1/7
8x 6, 1/4	11x 8, 2/3
10x 8, 2/1	12x 8, 2/6
10x 9, 2/4	12x 9, 2/10
12x 10, 3/-	14x 10, 3/5
14x 12, 4/-	16x 9, 3/6
14x 7, 2/7	21x 7, 3/7
16x 8, 3/2	24x 7, 4/-
8x 5, 1/2	in. thick
	Post Free.

Money back guarantee that each and all Panels are free from surface leakage Megger test Infinity. **CROXSONIA CO., 10, South St., Moorgate, E.C.2.**

Phone: Clerkenwell 7853
Agents: John Henry Smith, 139, Anlaby Rd., Hull.
L. H. Helyar, 82, Chamberlin Rd., Norwich.
A. Stredwick & Co., 27, The Marke, Chatham
Boynon & Co., Ltd., 34, Bradford St., Birmingham

WET H.T. BATTERIES
BUY BRITISH. Complete Units 3/6 per doz. All goods BRITISH MADE by BRITISH LABOUR.
Jars 1/3, Zincs 1/-, Saos 1/6 per doz. Carriage and Packing extra. Trade inquiries invited.—Demon Battery Co., 59, Badils Rd., Walthamstow, H.17.

**ACCUMULATORS
ON EASY PAYMENTS**

High-Tension Accumulators built up from 20-volt sections (15/- each). Example: 60-volt, H.T. 45/- CASH, or 12/6 DOWN and 6 monthly payments of 6/-. Carriage Paid. Satisfaction or money back. Write for Lists to DEPT. 11, COVENTRY DIRECT SUPPLIES LTD., 2, Warwick Row COVENTRY. Any Wireless Goods supplied on easy payments.

**EVERYTHING
RADIO
ON
EASY TERMS**
WOOLDRIDGE RADIO CO. LTD.
26 LISLE ST. LEICESTER SQUARE
LONDON. W.C.2.

REFUSE IMITATIONS!



Standard Size panels supplied in three finishes, Black polished, Black Mat, and Grain polished, carefully packed in attractive cartons. Every panel and piece of ebonite guaranteed and made by British hands.

ORIGINAL PRIZE - WINNING "BECOL" LOW LOSS FORMER, No. 5. 3 inch diam. overall.

Insist on a Becol Low Loss Former, the Former "with a reputation," incorporated in sets that have taken first four prizes and gold medal, a proof of their superiority. Supplied in cut lengths, 3 in., 4 in., 6 in., packed in cartons, and standard lengths of 3 ft.

Specify



Registered Trade Mark.

products



Apply for particulars of our new fool-proof 4 and 6 contact Former with bases ready for winding, directions and fully illustrated booklet, Price 6d.

THE BRITISH EBONITE COMPANY LIMITED, HANWELL.....LONDON.....W.7.

CLEARING LINES BARGAINS IN WIRELESS COMPONENTS

- 0003 Variable Condensers with Vernier 2/9
- 4 volt Bright Emitter Valves, Low Consumption 1/11 each.
- W.C.R.S. 30 ohm Rheostats for Panel Mounting, wonderful value 11 1/2d. each.
- Litron Jewel Crystal with cat whisker. Usual price 1/6 6d.
- W.C.R.S. Powerful Headphones. 4,000 ohms., per pair 6/6
- N. and K. pattern Headphones. 4,000 ohms., per pair 8/6
- 2-way Coil Holders for Baseboard or Panel mounting. Best Matt ebonite 3/16" thick, 3 sq. inches, 1d. Polished, as above, 2 sq. inches 1d. ANY SIZE PANEL CUT. 1/11
- 4 volt '06 Dull Emitter Valves 3/11
- W.C.R.S. Low-Frequency Transformers, 5 to 1 or 3 to 1 3/11 each

SEND FOR BARGAIN LIST AT ONCE. NOTICE.—Any of above goods will be sent POST FREE.

WEST CENTRAL RADIO SUPPLIES, 259, GRAY'S INN ROAD, KING'S CROSS, LONDON, W.C.1.
Open till 8.30 p.m. on Saturdays. Telephone: Museum, 3121

GRAHAM-FARISH

Ohmite NEW PROCESS

ANODE RESISTANCES ARE BETTER THAN WIRE WOUND!



2/3

sizes 10,000 ohms, to 1/2 megohm.

Announcement by GRAHAM-FARISH of BROMLEY, Kent.



Fresh as the Dawn every morning!

A PERMANENT SOURCE OF H.T. SUPPLY THAT RE-CHARGES ITSELF WHILE YOU SLEEP.

NO matter how much you use it—night after night, week in and week out—the Standard self-generating Leclanché battery will provide your set with abundant H.T. supply.

Enthusiasts everywhere are loud in its praise, and they have good cause to be!

It brings constant, permanent, unfailing H.T. current at a price within the reach of all. The secret IT RE-CHARGES ITSELF OVER-NIGHT!

Get this Free Book

Stocked by Halford's Cycle Stores. State number and type of valve when ordering.

For 2 Valve Sets, A.4, 90 volts, 25/1.

For 3-5 Valve Sets, D.6, 108 volts, 37/3.

For Super Sets, F.6, 126 volts, 69/6.

Goods for 10/- or over carriage paid. Deferred Terms easily arranged.



Take the first step by sending for FREE Booklet describing every detail for installing and maintaining this super-efficient and money-saving battery.

Write NOW to: (Dept. A), WET H.T. BATTERY CO., 12, Brownlow Street, London, W.C.1.

STANDARD SELF-GENERATING



The Vital Power in Radio!

Reliability

WIRELESS COMPONENTS
GIVE UNEQUALLED SERVICE



ORDER FROM THIS LIST
AND SAVE MONEY

Orders 5/6 value carriage paid.
Under 5/6, 2d. per 1/ for packing, etc.

(S) S.L.F. CONDENSER



Ebonite Ends & 4' Trolite dial '0005 5/9' '0003 5/6. Vernier dial extra 1/6

ACCUMULATORS.—Exide D.T.G. 4/6, D.F.G. 8/6, W.J. 10-v. H.T. type 5/-, 20-v. 12/6, OLDHAM 20-v. H.T. unit, 12/6; AERIALS.—100 ft. 1/ copper tape 1/9, 7/22's Bright 2/3, Enamelled 3/3, Electron 1/8, Superlat 2/6, O.V. complete 2/6, Ashton Spreaders 12/- pr. INSTALLATORS.—Large Shell 33/-, Reel or Egg 1 d., Olimax 1/- pr., ditto with shock absorbers 3/- pr. Gal. Pulleys 4d., 100 ft. Gal. Straining Wire 1/6, Straining Bolts 6d. BATTERIES.—Reliability 90-v. 11/-, 60-v. 7/-, 36-v. 4/6.

CONDENSERS.—Dubilier K.C. slow motion, '0005 12/-; Reliability S.L.F., '0003 5/6, ditto '0005 5/9; Igranic B.B. Neut. 4/-; Formo mid-log 10/6; Jackson '0005 11/6, Neut. 3/6; McMichael Balancing 4/9; Peto-Scott Mldgat 5/6, Neut. 5/- & 6/3; Ormond No. 3 S.L.F. '0005 mfd. 6/-.

VERNIER (23)

2-COIL HOLDER



Slide Action
For Baseboard 3/6 or Panel

H.F. TRANSFORMERS.—R.F. Straight Line and Multi Ratio 25/-; General Purpose type 15/-; Ferranti A.F.3 25/-; A.F.4. 17/6; A.F.5. 30/-.

VERNIER COIL HOLDER



2-way geared Coil Holder with metal work nickel plated, long control 3/- handle

VALVE HOLDERS.—Benjamin Antiphonic 2/-; Lotus 2/6 & 2/3; W. & B. 1/9; Cason 1/-; Burndept 2/9; Harlie 1/4; Reliability, unequalled, 1/2; N.P. Valve Sockets, flush fitting, 2d.; Superior 6d. Redfern's Rubber Holder, 2/6. H.F. CHOKE COILS.—R.I. & VARLEY 9/6; Wright & Wearie 6/6; Watmel 5/-; McMichael & Lissen 5/6. HEADPHONES.—Lissen 8/6; Reliability 5/6; Adjustable 8/6; Dr. Nesper 12/6 & 8/11; B.T.H. 15/-; Brandes 13/6.

H.T. BATTERIES.—Eveready popular 60-v. 9/6, 100-v. 15/6; Siemens 60-v. 9/6, 100-v. 15/6; Lissen 60-v. 7/11, 100-v. 12/11; Hellesen 60-v. 12/6, 99-v. 21/-, 15-v. 3/9.

D.P.D.T. ANTI-CAPACITY SWITCH

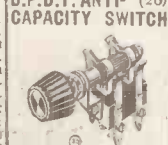

One hole fixing. Off position. Self cleaning contacts 3/-

GRID BATTERIES.—Lissen 9-v. 1/6; Siemens 2/-; Hellesen 2/-; Ediswan 2/6; Reliability 1/3, 6-v. Ever-Ready 1/3; TUNING UNITS.—R.I. & Varley standard 39/6, with condenser 47/6; Brilligam type 'A' 18/6; LampLight 35/6.

TOOLS.—Izlon Hand Drill 3/6, Six Drills 1/3; Soldering Iron 6d.; Electric Soldering Iron 10/6

(7) MULTI-BORER for EBONITE

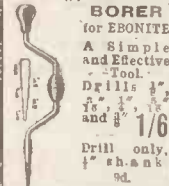

A simple and effective tool. O 1/2, Drills 1/2, 1/4, 1/8, and 3/16 Drill only. 1/2 shank ad.

RESISTANCE CAPACITY COUPLING UNITS.—Ediswan R.C. 'Threecore' 7/-; New type, with holder and plug connections, 9/-; Lissen 4/-; Polar 1st stage, 80,000 ohms, 7/6, subsequent stages, 40,000 ohms, 6/6; Cosmos 1 type, 8/6; Dubilier 7/-; Mullard P.M. 17/6; R.I. & Varley, Type A 20/-, Type B 22/6.

L.F. CHOKE COILS.—Lissen 5/6; Watmel 15/6; Igranic 27/-; Ormond 15/-; R.I. & Varley 21/-; Success 8/-.

POLARITY INDICATOR

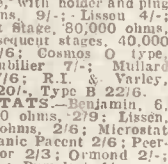

indicates A.C. or D.C. Immediately Price 3/6

FIXED CONDENSERS.—Athol, Dubilier, Edison-Bell, Igranic, Lissen, McMichael, Mullard, Watmel, at advertised prices. Reliable Condensers. Mansbridge type, .25 mfd. 1/6, .5 mfd. 1/9, 1 mfd. 2/6, 2 mfd. 3/6.

VALVES.—B.T.H. Burndept Mullard, Cosmos, Cossor.

WIRELESS CABINETS



For Panels 1in. high Width 9in. Hinged Lid Oak 12 in. 17/-, 14in. 17/6, 18 in. 18/6. Mahogany 1/- extra.

EBONITE.—Reliability Matt. 1/2 panels any size, 1 d. sq. in. Polished, 1 1/2 x 9 3/4, 12 x 9 3/4, 15 x 9 3/4, 12 x 12 3/4, 15 x 12 3/4, 18 x 12 3/4, 15 x 15 11/3, 12 x 12 1/2, 7 x 21 1/2, 3. Resistor 9/3.

SEND FOR FREE COPY RELIABILITY WIRELESS GUIDE No. 299 WITH ELECTRICAL SUPPLEMENT. Crammed with Wireless Bargains.

J.H. TAYLOR & CO.

4. RADIO HOUSE, MACAULAY ST., HUDDERSFIELD. Tel. 341. Grams: 'THOROUGH' HUDDERSFIELD.

THE "PROGRESSIVE" ONE.

(Continued from page 646.)

Now don't start the wiring with a rush, haphazardly connecting up leads here, there and everywhere. You will notice that all the lead numbers are repeated in the top right-hand corner of the wiring diagram. Start the wiring by connecting up lead No. 1 according to the point-to-point list and the diagram, and when this lead is connected cross out the "1" in that group of numbers. Carry on right down the list of numbers like that until all of them have lines drawn through them. You will know when this point is reached that every lead is in place and none has been left out.

If the work is interrupted, you can pick it up again without trouble and without missing a single connection. I hope you will understand this number business—I have made it as simple as possible, and I won't insult your intelligence by an over-elaboration in words!

Operating Details.

The two flexible leads (17 and 18) should have little clips on their ends or small terminals, although I must admit I used 26-gauge wire and made connections merely by twisting the ends on to the tapping points of the coil!

The flexible lead from the aerial terminal should be connected to either one of the two 20-turn tapping loops. Needless to say, the insulating covering of all the loops should be removed. When the aerial flexible is connected to the bottom tapping loop, less selectivity and probably greater signal strength will be obtained. The other flexible (from one terminal of the '0003 mfd. variable) should be connected to one of the '10-turn tapping loops. If the set oscillates too easily, the lead should be joined to the second or third from the top. If reaction is difficult to obtain, it should be connected to the top loop which represents the very end of the coil.

I am going to advise a valve of rather a high impedance for this one-valver—that is, a valve more suitable for high-frequency than for low-frequency amplification. A valve of the D.E.3H.F. or Ediswan E.S.5 H.F., Cossor Point One H.F., Mullard P.M.1, L.F., etc., are most suitable, but don't use one of the R.C. valves having a very high impedance. Practically any valve will work in this set, but you will be wise to ask your dealer for one which has an impedance of something around about 20,000 ohms.

A Test of Efficiency.

You won't find this one-valver difficult to handle, but I do not want you to carry on with next week's work until you are able to tune-in quite a number of stations on the telephone receivers within a short period of time. When, for instance, you can bring in ten stations quite clearly in ten minutes, then you can say that the one valve is O.K. Now for the next! I am not going to say anything more about the set this week; simply because I want to leave just a little for you to find out, and also have no more space left.

Having mastered the detector stage thoroughly, you will discover that the handling of an H.F. stage is by no means as difficult as some would have one believe.

10/- down

SECURE

Immediate Delivery (to approved accounts) of Complete or Partial Kit of Parts for the—

Cossor MELODY MAKER

Balance by Easy Monthly Payments.

HERE ARE A FEW ITEMS:—

- COILS (ready wound) - - - 7/6
- CABINET - - - - - 30/-
- BASEBOARD - - - - - 2/-
- RED TRIANGLE PANEL (drilled) 9/6
- TERMINAL STRIP - - - - - 2/3

Delivery from stock in strict rotation.

We also supply Sets, Loud Speakers, H.T. Accumulators and Mains Eliminators.

Write to:—DESK "P"

New Times Sales Co.,

58, Ludgate Hill, E.C. 4.

P.S. 1029

CONDENSERS! of QUALITY!

No mass production methods are employed in the manufacture of Camden Condensers. Every Condenser is stamped with a Serial No. and accompanied with a guarantee of 6 months' real service. Send for list and prices to Camden Electrical Co., Stanley Chambers, Lincorn.

"EMACO" SEND TO-DAY "EMACO"

List No. 93. "EMACO" CRAFTSMANSHIP CABINETS READY
MELODY MAKER 32/- EVERYMAN FOUR 55/8
NELSON - - - 36/- THREESOME - 16/8
SOLODYNE - - 98/- 1927 FIVE 58/-
Cabinets for all sets made.
ENTERPRISE, 11, GRAPE STREET, LONDON, W.C.2.

REPAIRS—THREE MONTHS' GUARANTEE

accompanies all our repairs. Any make of L.F. Transformer, Headphone, or Loud-Speaker, repaired to maximum efficiency 4/- Post Free. Terms to Trade, 24, HIGH ST., COLLIERS WOOD.

REPAIRS, LONDON, S.W.19. (New Address).

COMPLETE SETS, LOUD SPEAKERS, COMPONENTS, ETC.

Send list of requirements, and best monthly terms will be quoted by return.

Best British Batteries 60-v. 8/-, 103-v. 15/-, Pos. Free
THE P.D.P. COMPANY,
41, GREAT TOWER STREET, LONDON, E.C.3.

WET H.T. BATTERIES

Solve all H.T. Troubles. SELF-CHARGING, SILENT, ECONOMICAL. JARS (waxed) 2 1/2" x 1 1/2" sq. 1/3 doz. 2 INCS, new type. 11d. doz. SACS 1 1/2 doz. Sample doz. (18 volts), complete with bands and electrolyte, 4/3, post 9d. Sample unit, 6d. 16-page booklet free. AMPLIFIERS: 1-VALVE 49/-, 2-VALVE 30/-, 2-VALVE ALL-STATION SET 44/-
P. TAYLOR, 57, Studley Road, STOCKWELL, LONDON.



Don't treat your Valves like an Ass!

If your dealer cannot supply we send post free.

THE overburdening of Valves is so common, that the Ashley Resistor method of prevention when adopted, not only takes the extra load from the battery but relieves the burden of anxiety on the minds of those who may have to foot the bill for replacements.

And similarly, each of the other Ashley components perform their various functions reliably in the Home Set, so that nothing will go amiss in the absence of the person whose pet it may happen to be.



RESISTOR AND BASE 2/6

State particulars of valve for which Resistor is required when ordering.



MULTIPLE FIXED CONDENSER 5/6

15 various capacities from the one unit.

R.C.C. UNIT 5/6



Neatest and most reliable at lowest price obtainable.

GUARANTEED COMPONENTS



Two fully descriptive leaflets will be sent on request.

Ashley Radio

ASHLEY WIRELESS TELEPHONE CO. (1925) Ltd.
Finch Place, London Road, LIVERPOOL

COSSOR SPECIFIES T.C.C. IN FAMOUS "MELODY MAKER"

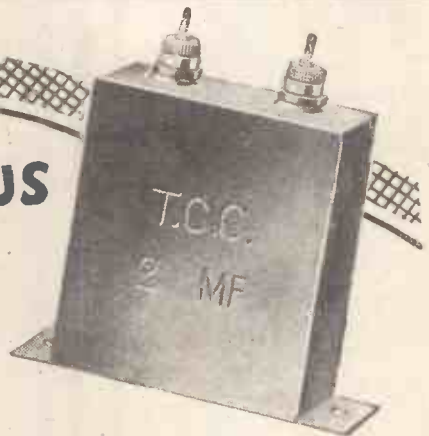

THE proof of the pudding is in the eating." Not for nothing have the leading Radio technicians used T.C.C. Condensers in most of the successful Sets during recent years. Not for nothing have the foremost Set manufacturers followed suit. And now—not for nothing has Cossor specified T.C.C. Condensers for use in the famous "Melody Maker." The reason? Just that T.C.C. has been found, in use, to be the utterly dependable Condenser.

T.C.C. Condensers

T.C.C. Condensers come in all capacities—each one guaranteed up-to-the-hilt. Mansbridge from '005, 1.8 to 10 mfd., 18/6. Mica from '0001, 1/10 to '3 mfd., 21/6.

Telegraph Condenser Co. Ltd., Wales Farm Road, North Acton, London, W.3.

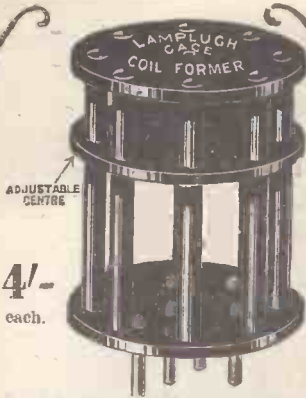

4/-
each.

CAGE COIL FORMER
LOW LOSS.

This unique Coil Former is built of finest quality ebonite turned from the solid. The centre-plate is adjustable so that Primaries can be wound on one side and Secondaries on the other, of various sizes. Actual winding size, 2 1/2" by 2 1/2". Overall size, 3 1/2" by 2 1/2".

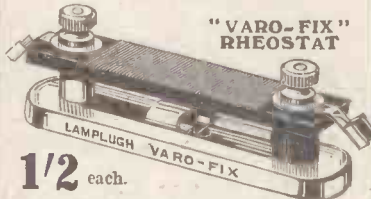

1 1/2 each.

This new model is built on aluminium base carrying special spring slider. Very compact, and can be placed near valve-holders, thereby reducing wiring. 6, 15, or 30 ohms.

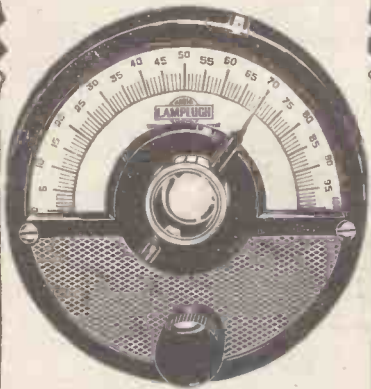

MICRO STATION SELECTOR

Correct ratio, permitting of quick and exceedingly slow motion. Entire absence of lash. A knife edge pointer for precision recording, as used in laboratories. Smooth and Positive drive. Elegant appearance and easy fitting. Fits 4 in. or 3 1/8 in. Spindles. Prices: Mahogany finish, 7/3. Black finish, 7/-.

VOLUME CONTROL
ONE-HOLE FIXING.

40,000 ohms resistance. Noiseless in operation and constant in value. Price 5/- each.

LAMPLUGH
BRITAIN'S
BEST RADIO

"LAMP-100"
S. A. LAMPLUGH, LTD.,
King's Road, Tyseley,
BIRMINGHAM.

Representatives for London and Southern Counties—G. G. Shore & Co., 28, Newman Street, Oxford Street, W.1.

SEND for LIST

SHORT-WAVE NOTES.

By W. L. S.

IT seems probable that before long the 45-metre wave-band will suffer a neglect almost equal to that accorded to the "late lamented" 90-metre band, if one can judge by the long-distance records that are being set up almost every day on the lower band—23 metres and thereabouts. Several British stations using a wave-length of 23 metres have worked every continent, most of the "active" countries of the world on this wave, using a maximum power of 10 watts. Indeed, there seems to be no point in using more. A prolonged "listen-out" on 23 metres is a very good test of a short-wave receiver, since sets that seem perfectly satisfactory on 45 metres will have all their faults shown up on 23 metres, and will sometimes be found to need rebuilding altogether.

Peculiar "Skip" Effects.

Incidentally, the amazing way in which the commercial stations have invaded these shorter waves is almost unbelievable. About every second degree on the condenser scale seems to become a hiding-place for a fresh one, and one begins to wonder whether there are any commercial stations left on the longer waves at all. Probably in two years' time all the broadcast stations will also be "down below," for it certainly seems possible by carefully designing both the transmitting and receiving aërials to cut out the "skip distance" bugbear altogether. 5 S W is received in south-west London at uncomfortable headphone strength on two valves; 2 N M is often quite inaudible, and never stronger than R3. In Paracombe, Devon, 5 S W is reported as very poor, while 2 N M is R8 or so. It is freaks like this that are holding back the development of short-waves for broadcast purposes.

There is a real thrill in hearing really distant stations for the first time, according to many letters received from readers, and this can only be done by building a short-wave receiver. All the European broadcast stations become "locals" at once, and 2 X A F of Schenectady is only "a fair distance." There is unquestionably going to be a big boom in short-wave reception this winter.

Another K D K A.

W I Z, the 43-metre nuisance, has stopped calling A B C at last. Whether he has succeeded in "raising" him after all these years is still a matter for conjecture. His place was taken by K D K A, or, perhaps one should say, a K D K A, since the family seems rather numerous.

With regard to the amateur traffic, South Africa (F O) A 9 A suddenly appeared on 38 metres in among all the European signals a few nights ago, and his own signal had just as much "punch" as most of the former. F I C W (Governo, Tripoli) was heard the same evening at very great strength. The time is both cases was about 6.30 p.m. By 8 p.m. the Americans are nearly in full swing, and the Antipodes stations may generally be heard at 5 or 6 a.m. Twelve hours at the receiver generally brings in all that there is to be heard on this planet.

LAKER STEEL MASTS
are 100 per cent. efficient
They are made by engineers and supplied to H.M. Government, the B.B.C., and to Colonial and foreign stations throughout the world. There are 50,000 "Laker" Masts in daily use. By mass production we are able to offer a wonderfully efficient and handsome Steel mast at the extraordinarily low price of 22/6 complete, as illustrated. Send 1/6 extra for part carriage. We pay the rest. Buy a Laker Mast for good reception.
JOHN & JAMES LAKER, Engineers, BECKENHAM, KENT.
30 ft. STEEL MAST 22/6

Your HOME Wireless!
Wireless Furniture, 3 ft. high—taking your Set, Batteries, etc., complete. Beautifully Polished OAK or Mahogany.
CABINETS for every Receiver!
Unrivalled selection — Lists Free. Picketts Cabinet (P.W.) Works, Bexleyheath.
From £5.5.0
Sent on APPROVAL.

ETON Primary H.T. Battery. P.1 Porous Pot Cells. S1 and S2 Sac Cells. All complete for assembly.

	1 cell.	6 cells.	12 cells.	30 cells.
P1	6/d	3/3	5/9	14/-
S1	6/1	3/-	5/3	12/-
S2	4/d	2/6	3/10	9/6.

Send 1/d stamp for booklet giving full particulars to: **THE ETON GLASS BATTERY CO., 46, St. Mary's Road, Leyton, E.10.**

HEADPHONES REPAIRED
Rewound and re-magnetised 4/- per pair Loud Speakers repaired 4/-. Transformers rewound 5/- each. All work guaranteed and tested before delivery. Write for Trade Prices. Phone: Clerk 1795. **MASON & CO., 44, East Rd., City Rd., N.1.**

EVERYBODY
wants to hear the
"ZAMPA"
3-foot Cone Speaker
For purity of tone there is nothing equal to it.
You can build one yourself in a very short time and for a very small outlay.
Write to-day for attractive brochure.
MIC WIRELESS CO.,
White Horse Place, Market St., Wellingborough

A.P. 4-ELECTRODE VALVES
Double Range and Triple Volume when used on your existing set and H.T. Battery.
SPECIAL H.T.-LESS VALVES and SCREENED GRID VALVES.
Write to-day for full data and X-ray photographs of the A.P. family.
ANELOY PRODUCTS
36, Hindmans Road, E. Dulwich, London, S.E.22
COSSOR MELODY MAKER COILS, 5/11.
Cabinet, oak, polished, 30/-; .0005 S.L.F. Variable Condensers, 3/11. British Dull Emitters, 5/-; 4" Dials, 1/3. Vernier, 3/11. Lotus Type Valve-holders, 1/3. Baseboard Rheostats, 6, 15, or 30 ohms, 1/-. All goods post free. Trade supplied.—**Tennants Wireless, Hylton Rd., Sunderland.**

THE WET H.T.
SMALL CAPACITY up to 8 MILLIAMPS
LARGE CAPACITY up to 16 MILLIAMPS
COMPLETE BATTERIES, ready wired, in Mahogany case, with glass cover, from 14/-. All parts supplied separate. Recommended by the Wireless Press. Send 1/d. stamp for folder, 6d. sample cell, or 1/- full range of samples, all capacities.
TROMBA ELECTRICAL CO., 13, High Rd., Kilburn, N.W.6.
Phone: Maida Vale 1669.

No coil changing!
No removable screens!
Perfectly balanced coils!

Panel Control
on multi-coil units!

Wave-length range
250/550 and 1,000/2,000
metres in one unit!

Convert your existing Solodyne

The set of coils DSP/3 will fit exactly into the space occupied by the old type of three separate screens and bases.

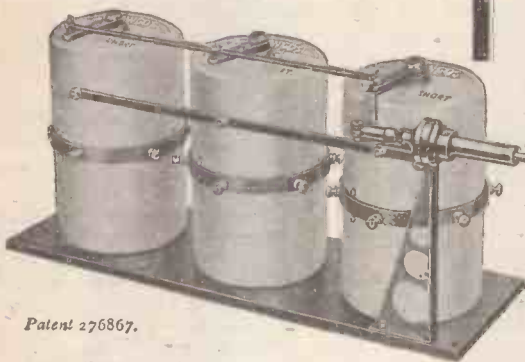

Patent 276867.

Another LEWCOS triumph!

THE LEWCOS DUAL-SCREENED COILS have been designed to facilitate the change from the 250-550 Broadcast Band to the longer waves used by Hilversum, Radio Paris, and Daventry. The change is effected by a switch incorporated in the coils and operated by a single panel control in the case of multi-coil sets and a lever in the case of the single Reinartz Aerial Coil. The two and three gang sets are perfectly balanced before leaving the factory, and are suitable for use with dual or triple gang condensers.

Ref. No. DRA/1	Single Coil Units Reinartz Aerial Coil	Each £1 12 6
Ref. No. DSP/2	Multi-Coil Units The SP Aerial Coil and one split Primary HF Transformer with Reinartz Reaction	Per unit £3 7 6
Ref. No. DSP/3	One SP Aerial Coil and two split Primary HF Transformers, the last with Reinartz Reaction	Per unit £5 0 0

Note.—Multi-Coil Units are supplied complete with panel control as shown.

Obtainable through all wireless dealers. Full particulars from
The LONDON ELECTRIC WIRE CO. & SMITH'S Ltd
 Playhouse Yard, Golden Lane, London, E.C.1.

LEWCOS

DUAL SCREENED COILS

ELIMINATE HALF YOUR WIRELESS TROUBLES

FITAN HOVEY "portable AERIAL"
HOVEY

Indoor or Outdoor.

You will never be troubled by LIGHTNING, GALES or HIGH WINDS if you fit the HOVEY—the SAFE, EFFICIENT, NO-WORRY AERIAL. Improves reception immensely. Gives sharper and more selective tuning.

"HOVEY" Standard (round)

Indoor size 12 ft. x 2½ ins. diameter. Best quality white insulated wire. Three round spreaders. Improved rubber insulators. Large terminal for lead in attachment. Neat appearance. Gives maximum results for crystal or valve sets. **PRICE 2/6**

"HOVEY" SUPER (Flat)

Size 12 ft. x 4½ ins. Made of special multi-stranded cable giving greater conductivity than usual aerial wires. Best quality ebonite spreaders. Improved rubber insulators at each end. Large terminal for lead in attachment. **PRICE 5/6**

"HOVEY" SUPER—Silk

Dimensions and style as above. Made of best English Flex. In either of 4 colours, Old Gold, Red, Silver Grey and Maroon. An aerial for the most palatial Drawing Room. **PRICE 8/-**

"HOVEY" Aerials are obtainable of all wireless dealers or from the manufacturers.

The HOVEY Aerial Co.,
 10, Red Lion Passage, London, W.C.1



REFINEMENT IN RADIO

Price 14/6
 Price without Slow Motion Dial 11/6

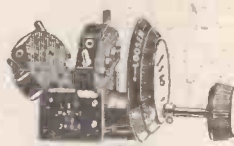

3 VALVES
20 Stations
ON
SPEAKER

One-dial Tuning—Razor sharp selectivity
 —No Coil-changing for High Waves—
 Real Music—Cost of Components £5.10.0.
 That's what you're looking for, isn't it?
 And it's a straight quick job for any beginner.

This amazing simple circuit is becoming the rage of the Season, and is already the envy and despair of H.F., screening and neutralising devotees.

Circuit and wiring diagram FREE in every box containing the L. & P. High-Low Coil Tuner. Obtainable from all good Wireless shops or direct from

LONDON & PROVINCIAL RADIO COMPANY LTD., COLNE, LANCs.

The L. & P. Variohm—the finest Resistor money can buy—is included in above estimate.



Zero to 10 ohms. Sealed, with off position. 4/-

THERE IS NO SUBSTITUTE

BARGAINS

MORSE WIRELESS RECORDERS, £7 10s. Wheatstones, £10. Magnificent British work, fine finish. Mahogany case with drawer for tape reel. Cost £30.

Anode Converters, 400 volts, £4 10s. Charging Valve Bargains, B.T.H., Cossor, etc., A.C. to D.C. 50 milliamps at 200 volts to 1,200 volts, cost 35/-. Sale 8/6, guaranteed.



ALTERNATORS, 70/-

Inductance Wire E. & C.C. Copper, Sale 1/6 lb. Paxolin Tubes 3x2 1/4, 4d. each, quarter usual price. Charging Valve Bargains, B.T.H., Cossor, etc. A.C. to D.C. 50 milliamps at 200 volts to 1,200 volts, cost 35/-. Sale 8/6, guaranteed. Switches. 250 volt Tumblers, 6d. 8-way Lucas or Phone or Speaker circuits, 3/6. S.K. Amplifier Micro, Units 2,000 ohms, 13/-. Buttons, 1/-. Western Electric Loud Speakers, 15/-. Violins, 25/-. Sullivan Headphones, 3/-. Single Phone, 1/6. Rubber Ear Pads, 4d. per pair. Gramo. Pick-ups, 21/-. Gyroscopes, 15/-. Mains Smoothing Chokes, 1/-. 2 mid. Condensers, 2/6. Remote Relays, 10/-. Pear-Pushes, 6d. Sterling 1-Valve Amplifiers, 22/6. 2-volt T.B. Amplifiers, 32/6. Inert Fuller, 1 1/2 cells, 1/-. New 8-v. Grid Bias Battery, 1/-. H.W. A.C. Meters 250 m/a, 15/-. Large Steel Horse-shoe Magnets for Coil Speakers, 3/6.

INSULATORS. R.A.F. Ebonite Aerial, 9 for 6d. Marconi Shell Strain, 4 ft., 2/-. Egg and Shrop, 2 for 1/6. Buldix Bell, porcelain, 1/6. Ribbed Pedestal, H.T., 2/-. Large Transmit, 4/6.

FOR THE LAB. Inductance Bridge, £17 10s. Paul's Bridge and Galvo, £9 10s. Res. Units, 2/6. Standard Mfd. Units, from 8/-. Wheatstone Bridges, 22 5s. and 26 10s.; New Sullivan Spot Galvo, Scale and Shunt, 21s.; 3-range Tinsley Micro Ammeter, 60/-. Capacity Bridge, 0001 to 10 mid., 28; Marconi B-T Direction Finder, £5 10s.; 3-set Valve Test Cabinet, £5 10s., etc. Megger 1,000 ohms to 10 megohms Tester, £15. Get the Best out of your set by using a Dix-Onemeter and a Wavemeter. Television Projectors, 25/-.
INSTRUMENTS. All ranges at low prices. For panel, 20 m/a., to 500 m/a., 6 amps. and 120 volts, C.Z. 15-0-15 amps., 15/-; 2-range voltmeters, 6 and 20 v. pocket and panel, 9/6; Moving coil panel Precision meters, 15/-, 17/6 and 22/6; 3-range milliammeters, 37/6; Micro-ammeters with mirror and pointer scale, 3-range, 5 to 500, £3; 500 volts, 55/-; 1,000 volts, £3; 1,500 volts, £5; 2,000 volts, £6; 2,500 volts, £6 10s.; 5,000 volts, £7 10s. Fine Moving Coil Instruments in Case. Quote new 15/-, worth double. Special Valve Characteristic Testers, Pol. Cabinet, 3 Moving Coil Meters on panel 7 1/2 x 9 1/2 in., socket for testing valves. Worth £10. Sale, £4 10s. each. A.C. Testers 108/B21, 4 ranges, 120 volt, 6 volt., 200 m/a and 4 amps., for 40-100 cycle mains, cheap at 45/-. 4-Range Westons 2 1/2 in., dial 0-6 a., 0-24 m.a., 0-120 m/a., 0-240 m/v. Cost, £4. Sale, 40/-. Ferranti Laboratory sets, mov. coil, mirror scale, knife pointer, 5 ranges. Millivolts to 250 volts, 1/10 Milliamperes to 25 amperes, and all between. Half price, £5 10s. Many other Bargains on view.

THEM-AMMETERS by Paul, Weston, Turner & Co., in ranges from 100 m/a to 3 amps., 75/- each. Silvertown Galvo, 12/6 and 15/-; Gambrell's Suspension Moving Coil, Price £3; Electradix ditto, cost £12. Sale 40/-; Universal-Shunts with four ranges, 35/-.

SPARK SETS. 10 in. Marconi Coils, £7; Cox X-ray, £10; 2 in. Sterling, 15/-; 1 in. Coils, 6/6; Diathermy 1 K.W. 100 volt D.C. to 20,000 volt A.C., £15; 250 watt 500 volt Alternators, 70/-.



THE DIX-ONEMETER

The 55 Range Rolls-Royce of Radio. An instrument of exact precision reading, 20 micro-amps, to 20 amps., 2 milli-volts to 2,000 volts. Measures Crystal Signals or Resistances from 50 ohms to 50 megohms.

INSTRUMENTS 55/-
MULTIPLIERS, each 6/6

NEW CATALOGUES NOW READY

72 Pages of Novel Apparatus, profusely illustrated; numerous new lines. Over 1,000 Wonderful Bargains. Splendid Selection of Instruments. Send 4d. stamp for a copy.

BARGAIN RECEIVERS. These are all first-class make. Royalty paid. Free trial. 2-Valve, No. 33 Marconi Lid Case, all wave-lengths, 50/-, cost £10. 2-Valve Mark 32, 250 to 1,800, £4. Western Electric 3-Valve, £6 5s. 3-Valve Aircraft, £4. Polar 4, Pol. Cab., £6 10s. 5-Valve R.A.F. with Valves, £5. 6-Valve Marconi De Luxe, £8. Sterling Surplus Anodian, £5 10s. Marconi R.B.10 Crystal and 1-Valve closed Cabinet. Complete with Valve, 22/6. Marconi Screened 6-Valve, £12. Cost £50.

Send 4d. for 72-page illus. Catalogue. It will save £4

ELECTRADIX RADIOS
218, Upper Thames St., E.C.4

TECHNICAL NOTES

(Continued from page 650.)

(especially if these are corroded and difficult to shift), but also for making quick connections generally. Strong spring clips, with sharply toothed jaws, are now available in various sizes and at very low prices. These are usually provided with small nuts and bolts, to which wires may readily be connected, and also with channels for making soldered connections.

An investment in a dozen or so of the smallest size (I think the retail price runs about 2d. each) is well worth while, in consideration not only of the convenience but also of the saving in time and temper.

A German Tuner.

I notice in one of the German papers a description of a new type of tuner, which is contained in a vertical cylindrical celluloid container, the coil having a series of tappings which go to a row of terminals on the lower end of the container, whilst the circular condenser dial is mounted upon the upper end of the cylindrical container. The whole is very compact, and it is designed to cover a wave-length from 250 to 2,000 metres.

The By-pass Condenser.

In view of the rapidly increasing popularity of H.T. accumulators as compared with H.T. dry batteries, a question which (in one form or another) has been put to me several times lately is as to whether the bypass condenser, which is so commonly recommended with H.T. dry batteries, is desirable also with H.T. accumulators.

In order to answer this question fully, we must take into account the fact that even in the case of the H.T. accumulator the condenser acts as a bypass for high-frequency and low-frequency currents across the H.T. battery. It is well known that in the absence of a bypass condenser more or less damping and distortion are likely to be introduced. It is, therefore, better to retain the bypass condenser, if you are using one, even though you may change over from H.T. dry batteries to H.T. accumulators.

With an H.T. dry battery, however, a bypass condenser of large capacity, say 2 or even 4 microfarads, is very desirable indeed, as the internal resistance of the dry battery is much higher than that of the accumulator, even when the dry battery is new, and in course of time the internal resistance of the dry battery may increase very rapidly, whereas the internal resistance of the accumulator remains always comparatively low.

Crackling.

Unless the H.T. accumulator has been very seriously neglected it is very unlikely that it will develop the crackling noises which are so commonly associated with an H.T. dry battery which is beginning to feel the effects of old age. By the use of a large-capacity condenser across the H.T. dry battery, the useful life of the latter may generally be extended considerably.

To sum up, on a change-over from dry battery to accumulator battery, the bypass condenser is not nearly so important, but at the same time if it is at hand it should be used.

Valve Styles.

It has now become more or less customary to think of valves as high-frequency amplifiers, low-frequency amplifiers, detectors, power amplifiers, and so on. This method of classifying, however, is rather loose, and in view of the great developments and refinements in valve manufacture it less and less conveys any useful information.

The impedance of the valve is really one of the most important points we should have in mind when we consider the suitability of the valve for a particular purpose. For example, a so-called high-frequency amplifier will usually have a fairly high impedance of, say, 20,000 ohms or more. I am not considering for a moment the filament rating, as a valve of the required anode characteristics may be obtained of any of the usual filament ratings and may, therefore, be selected to suit the low-tension battery or other source of low-tension supply.

For a given impedance, naturally it is desirable always to obtain the highest possible amplification factor. For a high-frequency amplifier an average amplification factor of 20 might reasonably be expected, but this again depends to some extent upon the design of the valve and also upon the actual filament voltage rating.

"General Purpose."

A so-called high-frequency amplifier with an impedance of say, 20,000 ohms, so far from being limited to high-frequency amplification, will as a rule be found useful as a detector, or even as a low-frequency amplifier (for the first stage).

Power valves, of course, come within the 5,000 to 10,000-ohm category; and are capable of carrying heavier anode currents. The more modern "super-power" class is generally considered to include valves of rather lower impedance, say, up to 4,000.

At the other end of the scale, valves with very high impedances, up to 100,000 ohms, are available for special purposes such as for use as tuned-anode high-frequency amplifiers, for anode rectification, and in conjunction with resistance coupling.

HAVE YOU SEEN

The DECEMBER issue of

The WIRELESS CONSTRUCTOR?

This is a magnificent XMAS NUMBER and contains, among other things, a full description of

THE "STRAIGHT-LINE" FOUR

A magnificent long-range loud-speaker receiver designed and detailed

By PERCY W. HARRIS, M.I.R.E.

The price of this excellent number is 6d. as usual.



**Valves with the Wonderful
Mullard P.M. filament.**

Generous valves—valves that give astounding performance, ample power and beautiful purity; valves that stand the knocks and jolts of a valve's life, because they are robust—and yet valves that are cheap in use, because they cut down current consumption and require only .075 ampere filament current—these are the valves with the wonderful Mullard P.M. Filament.

Fit them to your set, they will improve your radio reception.

Mullard
THE · MASTER · VALVE

The *ONLY* Transformer



THE new R.I. and Varley Straight Line Super Transformer is the only Transformer which has succeeded in combining real efficiency with almost universal application. As a simple transformer it is second to none. The iron content of this model is considerably greater than in other transformers, and further the iron used is of special grade, much higher in permeability, and lower in core losses than was hitherto obtainable. Some idea of what has been achieved can be gauged from the fact that at 50 cycles its inductance is 122 henries, and at 500 cycles, 123 henries. The remarkable curve, taken by the National Physical Laboratory under normal working conditions, shows its amplification to be practically a straight line from 100 to 6,000 cycles, with exceptionally good results even as low as 20 cycles.

The R.I. and Varley Straight Line Super Transformer has no less than twelve applications in addition to that of a simple transformer, one of which makes possible for the first time the new Balanced Inductance method of L.F. Intervalve Coupling.

This new Transformer is in no way a multi-ratio component in the same sense as our famous Multi-Ratio Transformer, in that this Super Transformer is suitable for valves with widely varying impedances. Reference to the diagrams—supplied with each instrument—shows that this Super Transformer is suitable for use with modern high magnification valves, and that, in addition, both the new method of Balanced Inductive Coupling as well as efficient L.F. Choke Coupling can be obtained with this component.



Full particulars with diagrams of the thirteen different applications of our new Super Transformer are supplied with each instrument. Write for the R.I. and Varley Catalogue, giving full particulars of our new products.

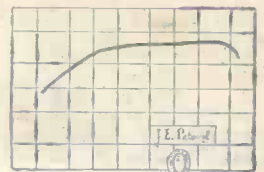

An exact reproduction of this Voltage Amplification-Frequency curve, bearing the seal of the National Physical Laboratory will be found in our illustrated 16-page Leaflet C.17 (free on application). Our new Booklet "Low Frequency Amplification" (Price 1/-) gives valuable up-to-date information on all forms of L.F. Intervalve Coupling.

THE MARK OF

R.I.
Varley

BETTER RADIO

Kingsway House, 103, Kingsway London, W.C.2.

Telephone: Holborn 5303.