

# Radio News

## OF CANADA

Stone and Cox Ltd.  
80 George St., Toronto.

Phones: El. 2283-2284

Vol. 8—No. 12

AUGUST, 1930

Price, 20 Cents

### Atwater Kent Announces New Models



The Atwater Kent Company have announced a number of new models for which their claims are high. This is an illustration of their new model No. 75, which is radio-phonograph combination.

## The Editorial Point of View



The present slump in trade, especially in the States, is, in our opinion, almost wholly the result of the Great War. Money came to the United States and Canada in enormous volumes to pay for supplies shipped to Europe. The United States in particular grew too rich for that reason. She is keeping Europe poor because Europe has to pay the war debts. Consequently Europe cannot buy American goods just now. If the States were to let up on their demands from Europe, then the peoples of the latter continent would start in to purchase more American products. You cannot keep your best customer poor and at the same time expect him to buy. Radio suffers by this condition just the same as every other business.

The broadcasting of R.U.R. led to an excitement which is still remembered. You may recall the story of the play, how the "robots" or mechanical workmen turned upon the human beings who manufactured them and fired the guns of a battleship at the factory. Cecil Lewis of the British Broadcasting Company produced the radio version and he was determined to have guns which sounded like guns. At the first rehearsal maroons were fired in the passage outside the Effects Studio. The result was unexpectedly violent. Savoy Hill (the broadcasting station in London, England) was shaken to the core. Smoke poured all over the building. After that, there were no more maroons. The Effects experts, who have the same passion for pure sound as Senior Wranglers have for pure mathematics, have been

responsible for many eccentric and disturbing occurrences in the Studios. A new office boy once begged to be relieved of his job; he had been passing the door of a studio when a hand came out and fired a revolver close to his head. That was in the old days before the up-to-date and efficient Effects Studio was put into commission and Savoy Hill had learned that small sounds made close to the microphone are as often as not more overwhelming in their effect than big sounds made far away from the microphone. A supreme illustration of this was the case of the aeroplane crash in a play called "Speed," which began as the overturning of a complicated structure, including a real aeroplane wing and ended up as the scratching of a matchbox close to the microphone.

The "Battle of the Giants" which was forecast in our editorial articles in October and November of last year, bids fair to develop into a stentorian bawling match between the high-power station in Moscow and those in neighbouring countries who do not altogether appreciate the propaganda transmitted by Soviet Russia. Germany has formerly protested against the messages broadcast on May Day from Moscow to the "Policemen and Soldiers of Germany," Rumania has a counter station which shouts down Moscow whenever it starts talking in Rumanian, and on the other side it is stated that a station is to be erected in the Volga Republic to drown the religious broadcasts from Berlin with the "Godless hour" from Moscow and prevent German settlers receiving Christian comfort from their fatehland.

Cynical prophets declare that when international disarmament is accomplished war will still be waged in the form of slanging matches through the medium of higher and higher-powered stations.

Wireless plays a conspicuous part on both sides of the game of rum-running as practised in the United States. On the one hand, we hear of secret transmitters discovered by the Federal Prohibition agents and, on the other side, of a sham SOS stating that the yacht in which the Mayor of New York was sailing was

in peril. All the coastguard patrol rushed to the rescue, leaving the coast clear for the bootleggers' agents.

The Expedition bound for Greenland in Shackleton's historic ship "Quest," which sailed from London, England, on July 6th, expects to set up base camps about the middle of August, one on the south-eastern coast of Greenland and the other 150 miles inland. The call-sign of the Expedition is GKN, and the wireless operator has arranged a regular schedule with G2CW, of Bath, nightly at 22.00 B.S.T.

The object in view is to establish an all-British air route across the Arctic regions to Canada, and the equipment includes aeroplanes, fast motor boats and sledges. From the central base exploring parties in dog sledges will journey northward, southward, and to the coast.

The meteorological section of the Expedition intends to remain at the main base for a whole year, this being the first time that an Expedition has spent a winter at such a high altitude in the Arctic. According to news lately received the party has reached the Faroe Island, where dog teams are being embarked.

A correspondent tells me that twenty-three hundred individuals in the United States, expressed in wireless communication, have organized themselves under the title of "minute men" of radio. They will form a nation-wide S O S organization, the purpose of which is to set up emergency communication in time of disaster, and when all other modes of communication are wiped out. The U.S. Navy and the Red Cross are the collaborating organizations which caused the creation of this radio chain, working with wireless operators and individuals. In an emergency, the first S O S to be sent out by a station will report the type and situation of the disaster and as much additional information as is immediately available. The second message to be sent will include the number of dead, injured, temporarily homeless, houses destroyed and damaged, and families affected. With this information available to the Red Cross, relief measures can be hurriedly organized.

# New Silver-Marshall Receiver

By Murdo Silver

Before describing these new sets, it is not out of place to call attention to at least four new features introduced by the 1929 Silver Radio which it was predicted would become practically standard for the entire radio industry by 1930, so great was their merit, and to note that this prediction has actually been realized. These four features, all introduced to the public originally by the Silver-Marshall laboratories, were screen-grid r.f. amplification, screen-grid power detection, tone control, and selector tuning. 1930 finds probably 99 per cent of all other radio manufacturers converted to the essential merit and worth of screen-grid r.f. amplification, and practically half to screen-grid power detection, while a large but still indeterminate number have been forcefully convinced of the merits of overtone control—two large manufacturers going so far as to base their entire selling campaign for 1930, so far as apparent at this time, on the tone control feature that S-M pioneered in 1929. Selector tuning, or the use of two critically coupled tuned circuits in place of one to obtain a steep-sided resonance curve, is also widespread this year—a feature that was practically exclusive with Silver Radio in 1929.

## Can a Radio be Too Sensitive?

One of the most talked-of features of the 1929 Silver Radio, made possible by its extreme sensitivity of

1 to 3.5 microvolts per meter or better, was its ability to operate without any type of external antenna at all,—requiring only the use of a small wire screen contained in the set cabinet as a signal collector. This was a very valuable feature, but it was found that many users felt that if the set would reach out several thousand miles with such a tiny antenna, then it would certainly reach out even farther if a nice big 100 to 200 foot antenna was substituted for the diminutive screen. The net result of this wide and general practice of using a large antenna was that when the very sensitive receiver was coupled to a large antenna, it did reach out farther, but the noise level also came up to a point which rendered the extreme sensitivity almost useless, so that the average distance range remained about constant for large or small antenna. But to the uninitiated, the increased noise level found between programmes, as the receiver was tuned from station to station when at full gain appeared as a drawback, few recognizing that the high sensitivity that brought with it the high noise level also accounted for the reception of more programmes than could be had on a less sensitive, and consequently

more quiet, set. The final conclusion, however, was that the original 1929 sets had appreciably more sensitivity than could beneficially be used by the majority of listeners, and as a result the 1930 models were designed with a sufficiently lower sensitivity to provide exactly the same performance using a forty foot antenna as did the first 1929 model when using the self-contained, or a ten foot external, antenna,—and to do so with an appreciably lower noise level.

## Features of the New Silvers

For 1930-31, two chassis models have been developed, in four different cabinet models. The essential performance difference lies in selectivity, and a minor difference in sensitivity. The more selective set has, also, automatic volume, or "fading," control. Both use an identical power and speaker unit, only the receiver chasses being different.

Type 34A chassis is a seven tube set (including rectifier), employing two screen-grid tuned r.f. stages, four tuned circuits, screen-grid power detector, resistance-coupled 227 first audio stage, and push-pull 245 power stage with Clough-system tuned audio transformer.

Type 35A chassis is a nine tube set (including rectifier), employing two tuned screen-grid r.f. stages, an aperiodic screen-grid r.f. stage, five tuned circuits, screen-grid power

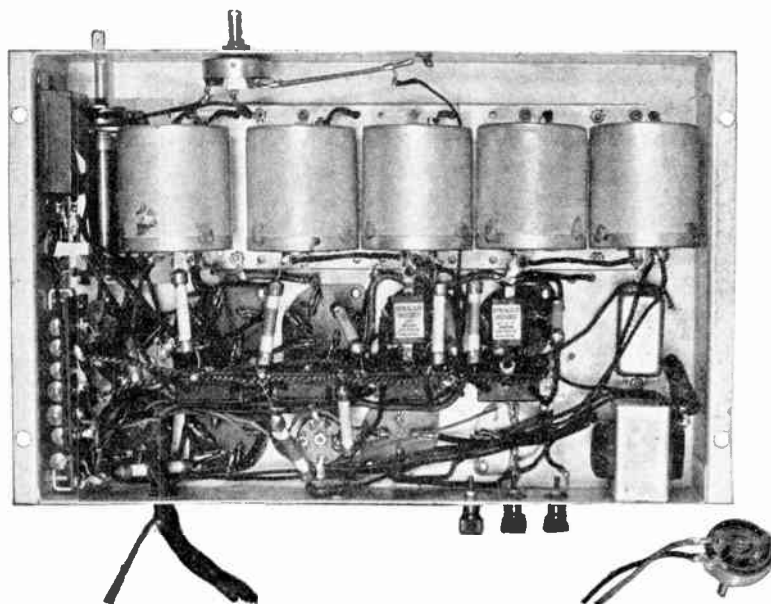

Bottom View: Type 34A

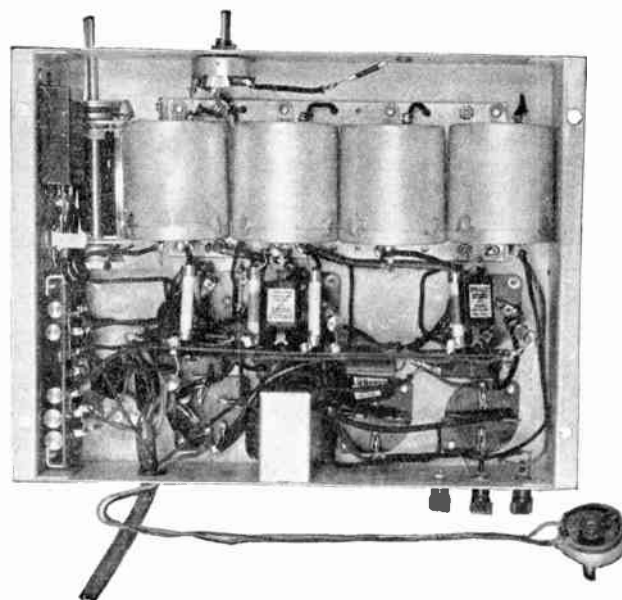

Bottom View: Type 35A

detector, and exactly the same audio system as the 34A. It incorporates a 227 automatic volume control tube.

Type 33A is the combined power and speaker unit used with either the 34A or 35A receivers. It contains an oversize power transformer, 280 rectifier tube, triple-section filter with self-healing electrolytic condensers, and a special nine inch electro-dynamic speaker unit giving excellent bass and treble response without cutting off either end of the needed frequency range to favor the other, as do so many dynamics.

Since the electrical design of both the 34A and 35A chassis is essentially similar except for the extra tuned circuit, aperiodic r.f. stage, and automatic volume control found only in Model 35A, it is convenient to consider them together. Both receivers employ a dual selector antenna input circuit, consisting of an r.f. antenna transformer having two taps on its primary so proportioned that antennas of up to 100 mmf. may be connected to it on the "short antenna" tap and up to 500 mmf. on the "long antenna" tap, without any derangement of the ganging of the tuning condensers. More simply, this means that average antennas of from 20 to 200 feet in length will have no deganging effect on the circuit. The two primary taps are brought out to the antenna binding posts on the rear of the receiver chassis. This first tuned circuit is coupled to a second coil, identical with the antenna transformer secondary, by a condenser of value greater than that necessary to obtain a double-humped resonance curve (or band selector), in order to

provide the greatest possible selectivity and the steepest possible sides to the resonance curve. As a matter of fact, it can be seen from the over-all fidelity curves that this has no serious effect on high audio frequency response, while it has a very beneficial effect on r.f. selectivity. The second tuned circuit feeds the grid circuit of the first '24 r.f. tube, which is biased  $2\frac{1}{2}$  volts negative. This high bias, plus the two tuned circuits preceding this first tube, effectively and completely eliminates any possibility of crosstalk or cross modulation, even though the set be operated very close to an extremely powerful broadcasting station.

The first r.f. tube is coupled to the second '24 tube, in the 34A chassis, by a single tuned transformer having a very high r.f. gain—ranging from 40 to 70 with the first tube. In the 35A chassis the first and second tubes are coupled by a dual selector circuit essentially similar to the antenna input selector, except that its first transformer is bifilar, giving a 1:1 coupling ratio and practically unit coupling. In this, as in the antenna selector, capacity coupling is used between the two coils of the selector, with the net result that high-frequency selectivity is almost equal to low-frequency selectivity—a sharp and pleasing contrast to other broadcast receivers with which it is seldom possible to adequately separate low-wave stations.

#### Gain Well Equalized

In the nine tube Type 35A chassis, the third tube is an aperiodic r.f. amplifier, coupled to the preceding r.f. tube by a small aperiodic bifilar-wound r.f. transformer of 1:1 ratio.

Two valuable effects are obtained from this aperiodic stage: the first an appreciable increase in over-all r.f. gain, and the second an r.f. gain characteristic sloping in a direction opposite to that of the other r.f. stages, to an extent tending to perceptibly equalize static or noise at all frequencies—a contrast to the majority of receivers, which show r.f. gain curves sloping down very noticeably from short to long waves, when, as a matter of fact, discrimination is desirable of an exactly opposite order. This aperiodic tube (or, in the case of the seven-tube Type 34A chassis, the second r.f. tube) is coupled to the detector by a tuned r.f. transformer essentially similar to the unit coupling the first and second r.f. tubes in the 34A seven tube chassis. The r.f. amplifier of both seven tube chassis. The r.f. amplifier of both receivers is inherently stable, due to individual shielding of r.f. coils and condenser sections, and the judicious use of isolation in the form of r.f. bypass condensers and chokes. The r.f. tubes are, of course, shielded, as is the detector, by individual covers.

A special advantage of the capacity-coupled selector circuits is that no section of the gang condenser need be disconnected while the other section in a given selector is being aligned, as is necessary with all selector circuits so coupled as to produce a double-humped, or "band selector" response curve.

The dial of the gang condenser is calibrated directly in kilocycles, for simplicity of tuning, and covers the range of 550 to 1500 k.c. Volume control is effected in the r.f. amplifier by varying the negative bias on the r.f. tubes—a smooth and simple method having no reaction on tone quality, as screen-grid voltage variation sometimes has. The screen-grid power detector is essentially the same as found in the 1929 Silver Radio, no better detector having yet been found. It is automatically biased in a manner which causes the detector to act as a limiting device for signal values appreciably greater than necessary to load the audio amplifier to its full capacity of 4.5 watts undistorted power output.

#### A Far Simpler Automatic Volume Control

In the past, automatic volume control has almost universally been effected by rectifying a portion of the signal appearing in the power detector circuit and using this rec-

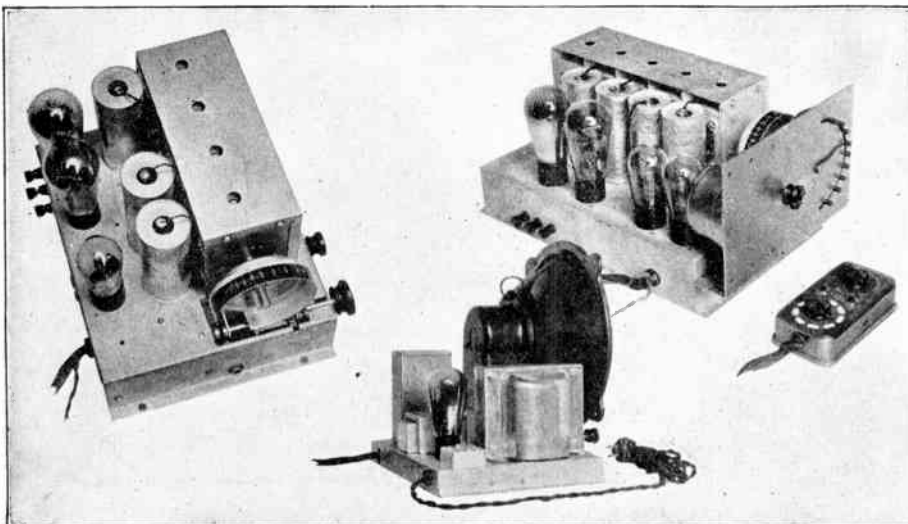

Chassis Models: 34A and 35A—with 33A Power Unit.

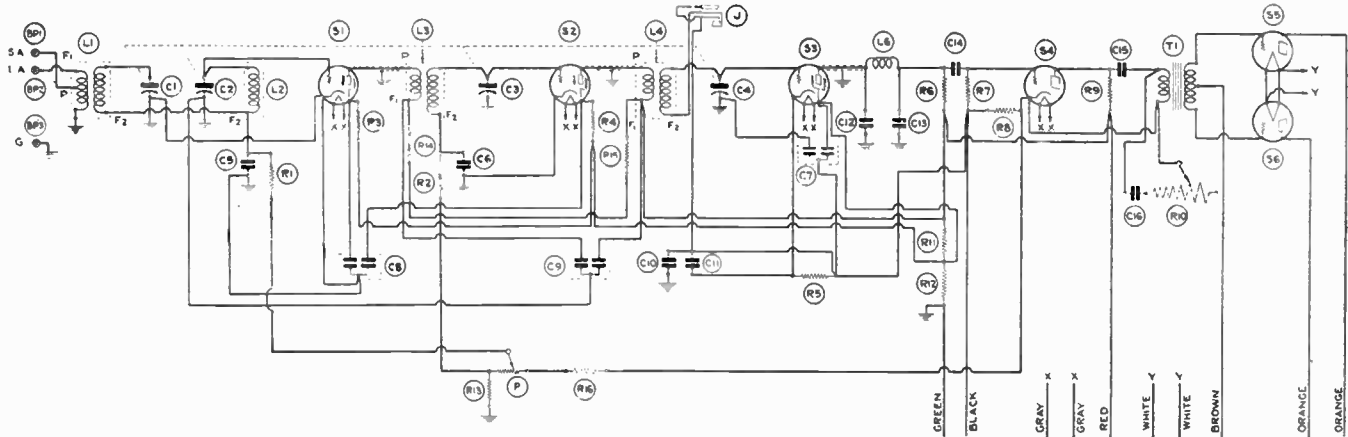

Schematic Diagram: Type 34A

NOTE: WIRE COLORS REFER TO WIRES IN POWER SUPPLY CABLE.

tified d.c. to shift the r.f. amplifier grid bias, thereby cutting down input to the detector until a state of equalization was reached. One of the disadvantages of this method is that quite high detector outputs are required, tending to operate the detector in a range often permitting overloading. A further disadvantage is that the time-constant of the automatic-volume-control circuit may be such that it will fall in the audio frequency range, and may cause the control to operate at audio frequencies, thus flattening off the sound peaks and badly distorting the output. Such systems are usually found in sets having but one audio stage, when the detector signal voltage is adequate to operate the control tube.

Due to the high sensitivity of the '24 detector in the Type 35A chassis, and the fact that the detector is normally operated at an output so low as to prevent overloading, such a system was not applicable, even had it been desirable. An entirely new type of automatic control was developed, employing a d.c. amplifier tube to operate from the varying d.c. bias of the automatically biased

detector, the output of this tube shifting the bias on the r.f. tube grids in a manner tending to produce constant r.f. input to the detector over wide ranges of signal field strength. The initial bias on the r.f. tubes is set at 2.5 volts, and an extra resistor is included in the common r.f. grid return. Since no direct current (d.c.) normally flows through this resistor, it has no effect on the bias potential. It is, however, included in the plate circuit of the volume-control tube, and when the detector grid bias is shifted less negative by a strong signal, plate current of the volume control tube flows through this resistor, setting up a voltage drop which is applied to the r.f. grids in addition to the initial 2.5 volts, thus cutting down the r.f. gain. In operation, once the desired volume level has been set by the volume control, any signal strong enough to operate the volume control tube, and all stronger signals, are held to substantially the same volume, and slightly weaker signals are lifted up to this level.

The normal volume control is a resistor tending to make the bias on the

control tube more or less positive, exactly as would a strong signal. As the grid goes positive, the plate current increases the drop across the plate resistor, which is applied to the r.f. tube grids. The volume control knob can be operated either to set a desired volume level for all stations, or to vary volume in the ordinary manner. This is in distinct contrast to previous types of automatic volume controls, where there was an r.f. sensitivity control, plus a straight volume control, necessarily in the a.f. amplifier, this combination easily permitting detector overloading with consequent signal distortion. Such systems have also required the use of a visual tuning meter with consequent further complication of the tuning operation. This is not necessary on the S-M system, tuning being done by ear, in the usual manner.

The '24 detector is coupled to the '27 first audio tube by two 300,000 ohm. resistors and a 0.1 mfd. condenser, giving a flat frequency characteristic over the audio range.

**No Hysteretic Distortion**

The '27 first audio tube is coupled to the '45 push-pull output tube by a  
(Continued on page 14)

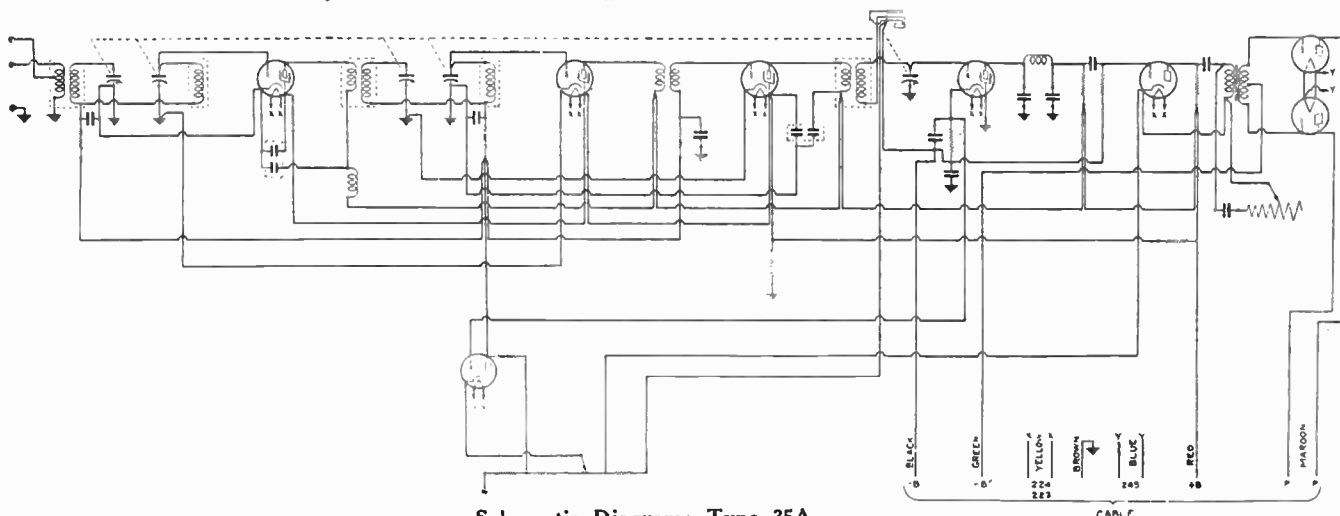

Schematic Diagram: Type 35A

## New Atwater Kent Models

In the announcement of the new radio, stress is laid on the quality and character of the tone of the instrument, while the new dial is presented as an important and revolutionary improvement. The features are described as follows:

"The improvements and refinements in the new Atwater Kent set make the name, "golden voice," a reality. Every sound that is broadcast comes in with infinite clarity, due to the extraordinary frequency range of the new circuit. The set gives an absolutely natural reproduction of every musical instrument and every human voice.

"The new quick-vision dial is a distinct innovation in appearance and mechanism. It is a wide, stationary, illuminated arc, above which moves a pointer when the station-selector knob is operated. The dial is graduated in kilocycle channels so that each division represents a station. Large figures from 60 to 150 indicate a kilocycle range from 550 to 1,500 and every part of the tuning scale is plainly visible at all times. Behind the panel a compensating mechanism operates the pointer and automatically counteracts the tendency of the kilocycle scale to "lunch" closely at one end. This makes the scale uniform and permits the operator to pick out any station as easily as he would tell time by looking at the clock.



The Atwater-Kent Control Panel, showing the new and exclusive quick vision dial. Left to right—Volume control knob, local distance switch, tuning knob, on-off switch and tone control knob.

"The new tone control provides four distinct shadings, permitting emphasis of bass or treble at will. This presents obvious advantages. One is the fact that it permits the listener to

strike his own balance between highs and lows and to adjust the tone to his individual taste. Static and other electrical disturbances may also be reduced through this device.

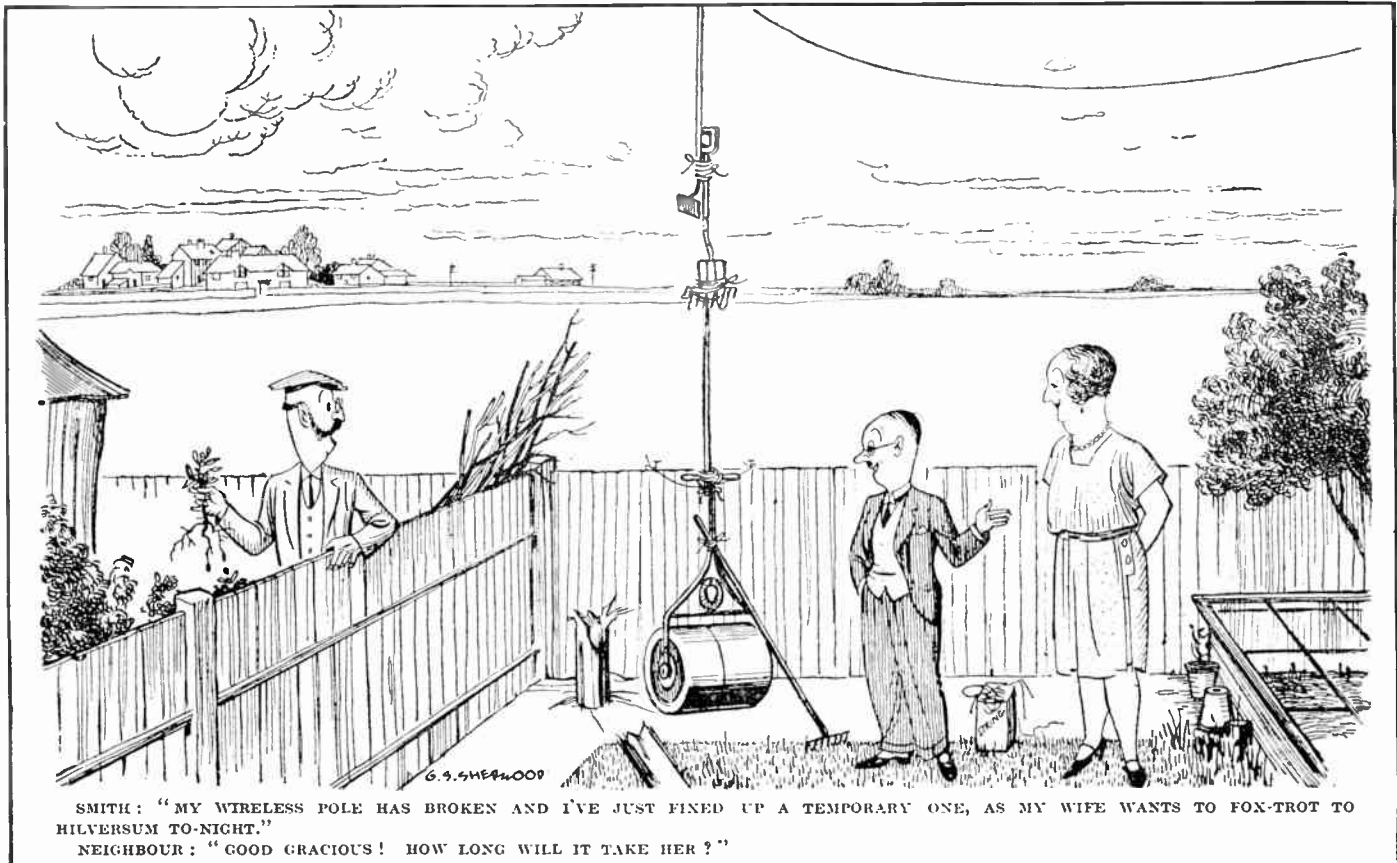

SMITH: "MY WIRELESS POLE HAS BROKEN AND I'VE JUST FINED UP A TEMPORARY ONE, AS MY WIFE WANTS TO FOX-TROT TO HILVERSUM TO-NIGHT."

NEIGHBOUR: "GOOD GRACIOUS! HOW LONG WILL IT TAKE HER?"

## One of the New Atwater Kent Models



This is the new Atwater Kent Model No. 74 Table. Finished with matched butt walnut, back and top, and may consequently be placed anywhere in the room.

"All four of the new cabinets are characterized by a general uniformity. They have been designed and built to Atwater Kent specifications under the company's supervision. The design, finish and dimensions are such that any of them blend harmoniously with

any kind of furniture or decorative background.

The models are as follows:

"Model 70 Lowboy, 38 $\frac{3}{4}$  inches in height, 24 $\frac{3}{4}$  inches in width, and 15 $\frac{1}{4}$  inches in depth. Finished in American walnut with matched butt walnut

front panels. The speaker opening is curtained with an especially rich, unobtrusive duotone fabric.

"Model 74 Table, 30 $\frac{3}{4}$  inches in height, 24 $\frac{1}{2}$  inches in width, and 16 $\frac{1}{2}$  inches in depth. Finished with  
(Continued on page 14)

# The Band-Pass Loftin-White Set

## Three-Tube Direct-Connected Receiver

By H. G. Cisin

Associate Radio Editor

Thousands of radio fans and experimenters have built the direct-coupled Loftin-White amplifier and their enthusiasm is justified, for no radio development in recent years offers more interesting possibilities.

The utilization of a three-stage band-pass filter system as a tuning unit makes the direct-coupled amplifier available as a powerful radio receiver, of most excellent characteristics. The band filter used, consists of three special coils or inductances tuned by three sections of a Hammarlund "Battleship" condenser, working simultaneously. A Silver-Marshall drum dial is used to turn the condenser. Each coil and condenser section is individually shielded and then collectively shielded to cut out interference. When a group of station signals whose wave lengths are near together come in on the antenna, this filter pre-selects only the signal desired and bars out all others, before any amplifying is done. The complete band-filter unit is available with all internal wiring of parts finished. The matched triple condenser is mounted in an aluminum shield and all units are connected to their respective inductances. The Hammarlund band-filter preserves the side bands containing the rich overtones and in combination with a direct-coupled amplifier and a high-grade dynamic speaker, gives the much-desired brilliancy, fullness and roundness of tone, generally noticeable only in the original music at its source.

In addition to the band-pass filter, the "Band-Pass Loftin-White Set" consists essentially of a direct coupled amplifier using two '24-type screen grid tubes and a '50-type tube in the output stage. The signal is tuned in or pre-selected by the band filter unit and detection occurs in the first screen grid tube (6). The direct coupling between the two screen grid tubes is highly advantageous, since it permits a greater efficiency with increased amplification per stage than would otherwise be possible. The '50-type tube is also worked at a point of high efficiency, so that the complete receiver has a distortionless output of nearly 5,000 milliwatts.

By adjusting the clip on the Electrad Truvolt resistance (12) it is

possible to reduce a. c. hum to a negligible minimum. Volume is controlled by means of an Electrad potentiometer tonatrol (3). The antenna coil of the band filter is tapped, so that the receiver can be used with equal facility on a long or short aerial.

Practically all the resistances specified for this set are Electrad Truvolts, with the exception of resistors (10) and (17) which are Electrad metallic leaks and variable resistance (8), which is a Royalty potentiometer. A Silver-Marshall r. f. choke is provided at the output terminals of the amplifier and this is by-passed by a small fixed condenser.

The high plate voltage necessary is obtained from a Thordarson T-2098 power supply transformer, especially connected to use a single '81 type tube, instead of two such tubes. The T-2098 supplies filament voltage for the '81 tube and also for the '50-type tube, a separate 7½-volt winding being available for the latter. A Thordarson T-3081 filament transformer is used to furnish the 2½ volts for the filament of the two screen grid tubes. The filter system utilizes a Thordarson R-196 choke, unit and a special high-voltage Polymet condenser block.

The various parts are mounted either above or below the deck of an aluminum chassis, with the Corwico Braidite wiring entirely out of sight below the chassis. The completed assembly is extremely pleasing in appearance. Even the four Eby sockets are mounted from below, with only the circular portions of the sockets showing from above the chassis. The volume control and switch are mounted on the panel and there is really very little work to be done in completing the set, since the tuner comes completely assembled and wired and the amplifier consists essentially of resistances. After the plate voltage has been adjusted at the '50-tube plate, all other plate and grid voltages are automatically brought to their correct operating values.

The chassis is bent to shape from

a piece of 14 to 16 gauge aluminum sheet, cut as indicated in the "chassis details" illustration. Holes are drilled for the four Eby sockets. The chassis is turned upside-down and the various Electrad resistances are mounted on the under-side.

The Polymet block condenser is fastened to the end support as shown, and the two smaller fixed condensers are also mounted at this time, as well as the Amperites and the two metallic leaks. The Silver-Marshall r. f. choke is mounted below the chassis deck, as shown at (35) and the Eby sockets are mounted from the underside.

The chassis is now turned right-side up and the position of the Silver-Marshall drum dial on the vertical center line, is determined. This in turn fixes the position of the entire Hammarlund band filter unit. Since the center of the drum dial is ¼ in. higher than the shaft center of the three-gang condenser, it will be necessary either to cut a slot for the dial in the chassis, or else to raise the band filter unit on washers. In the latter case, the dial is fastened to the deck of the chassis and then the band filter unit is also securely mounted on the chassis.

The Thordarson power supply transformer, the filament transformer and the Thordarson R-196 choke the next mounted as shown in the top view. The four insulated Eby binding posts are also fastened in their proper positions.

A hole is drilled in the center of the panel for the Silver-Marshall drum dial window, using the escutcheon plate as a template. A smaller hole is drilled below this for the drum dial drive control shaft. Mounting holes are drilled for the Electrad Tonatrol (3) and for the switch (30). Small holes are drilled at the lower part of the panel for fastening the panel to the front wall of the chassis. The escutcheon plate is fastened in place, the switch and volume control are also mounted on the panel and the panel is then fastened to the chassis.

It would be impossible to find an easier set to wire than the Band-Pass Loftin-White receiver. The Hammarlund band filter unit comes to the constructor completely assembled, wired, tested and adjusted.





Only three wires are brought out from this unit. The volume control potentiometer (3) is shunted across the ground and either one of the antenna loads (SA or LA), depending upon whether a short or a long antenna it to be used.

The matched triple "battleship" condenser is mounted in an aluminum shield and all units come connected to their respective inductances. The completed unit is given a thorough test at the factory and then the tops of the coil shields are soldered in place. The tuning coils used in the filter are wound on threaded bakelite forms and are matched to each other with an accuracy of better than  $\frac{1}{4}$  per cent. The triple-gang tuning condenser also has its individual sections accurately matched. Since the distributed capacities of the three tuned circuits differ widely from each other, a supplementary adjustable capacity is connected across each main tuning condenser. These supplementary capacities are adjusted so as to bring the minimum or inherent capacities of the individual circuits to exactly the same value. With the inductances and the individual tuning condensers matched, the three circuits will track throughout their entire tuning range.

With the volume control wired in, the next step is to wire the filament circuits. The two screen grid tubes (6) and (16), have their filament circuits in parallel, with filament voltage supplied by the Thordarson transformer (29). The filament current to each of these tubes is regulated automatically by Amperites (9) and (13). A 20-ohm center tap resistance is connected across the filament supply winding and the center tap is grounded. A separate filament circuit is wired to the power tube (20) from the winding provided for this purpose on the Thordarson power supply transformer (27).

The other  $7\frac{1}{2}$  volt winding on the power transformer is wired to the filament terminals of socket (28). All filament windings should be twisted to prevent a. c. hum. The grid and plate circuits are wired in next. Then the double grid and cathodes. Resistances (11), (12), (14) and (18) are connected in series. The intersection between (11) and (12) goes to the double grid ("G" at the socket) of tube (6). The double grid of tube (16)

connects to the intersection of resistances (14) and (18). The other end of (18) is connected to the mid-point of the center-tap resistor across the filament of the power tube.

The Polymet by-pass condensers (7) and (34) are then wired in. Next

### COMPLETE LIST OF PARTS REQUIRED FOR THE BAND PASS LOFTIN-WHITE SET

- 1 Hammarlund No. B 53 Three Stage Band Pass Filter Unit (4).
  - 1 Thordarson Power Supply Transformer, type T-2098 (27).
  - 1 Thordarson Filament Transformer, type T-3081 (29).
  - 1 Thordarson Choke Unit, type R-196 (25).
  - 1 Silver-Marshall Illuminated Drum Dial type 810-L (5); with  $1\frac{1}{2}$ -volt Pilot Light (31).
  - 1 Silver-Marshall R. F. Choke, type 275 (35).
  - 2 Eby Sockets, UY-type (6, 16).
  - 2 Eby Sockets, UX-type (20, 28).
  - 1 Electrad Antenna Potentiometer Tonatrol, type A (3).
  - 1 Electrad Royalty Potentiometer, type "J" (8).
  - 1 Electrad Truvolt Resistor, type B-4, (11).
  - 1 Electrad Truvolt Resistor, type B-10, (12).
  - 1 Electrad Truvolt Resistor, type B-15, (14).
  - 1 Electrad Truvolt Resistor, type B-30, (18).
  - 2 Electrad Truvolt Resistors, type D-250 (26, 26A).
  - 3 1 meg. Electrad Metallic Leaks, with mountings (10, 17).
  - 2 Electrad Truvolt Center-tapped Fixed Resistances, type B-2 or 2—Electrad type V-20 Center tap Resistances (19, 32).
  - 1 Polymet Loftin-White Filter Block Condenser, type F-1016 (23-2 mfd.), (24-1 mfd.), (33-1 mfd.), (15-.5 mfd.).
  - 1 1 mfd. Polymet "Hi Volt" Paper Condenser, type C-904 (7).
  - 1 .001 mfd. Polymet Mica Condenser, type MC-1212 (34).
  - 2 Amperites No. 227, with M't'gs (9, 13).
  - 4 Eby Engraved Binding Posts (1, 2, 21, 22).
  - 1 Electrad Power Switch (30).
  - 1 Roll Corwico Bradite Hook-up Wire, Solid Core.
  - 1 Can Kester Radio Solder (Rosin Core) by the Kester Solder Company.
  - 1 Composition Panel, 7 in. x  $20\frac{1}{2}$  in. x  $\frac{3}{16}$  in.
  - 1 Aluminum Sheet, 14 to 16 gauge, size 24 in. x  $11\frac{1}{2}$  in., cut and bent so as to form chassis, 20 in. x  $7\frac{1}{2}$  in. x 2 in. high.
  - 2 Screen Grid Clips.
  - 2 Triad Screen Grid Tubes, type T-24 A. C. (6, 16).
  - 1 Triad Power Tube, type T-50 (20).
  - 1 Triad Half-Wave Rectifier Tube, type T-81 (28).
  - 1 Wright-DeCoster Dynamic Reproducer, type 107.
- Note: Numbers in parentheses refer to corresponding numbers marking parts on diagrams.

the high voltage winding of the power transformer is connected as shown, with one end grounded to the chassis and the other end connected to resistor (26-A). The other end of (26A) is connected to (26) and the end of the latter is connected to the center tap of the high voltage winding. The filter system, consisting of the Thordarson R-196 choke and the Polymet condenser block is wired in, as indicated on the diagram.

The primaries of the two Thordarson transformers (27) and (29) are connected in parallel with a brake in one side of the power supply line leading to the switch (30). The pilot light (31) is wired to the  $1\frac{1}{2}$  volt winding of the filament transformer (29). This completes the wiring, which is all performed with Corwico solid core braidedite and concealed below the deck of the chassis. Kester resin core radio solder is recommended, as its use will insure rapid, efficient work and secure, permanent joints.

To adjust the receiver, the first step is to secure a voltage of 750 volts between post (22) and ground. The plate of the half-wave rectifier tube is connected to one of the sliding terminals on (26) or (26A). It will be necessary to move the slider one way or the other until the voltmeter registers the desired 750 volts. As soon as this is done, all plate, double grid and other voltages will automatically be brought to their correct values, due to voltage drop in the various resistances.

Resistance (8) should be adjusted until best tone quality is obtained. The current flowing through (8) should be about 18 to 21 microamperes for best results. If no meter is available, adjust for best reproduction, leaving it set at this position. The "hum buck" control is shown at (12). However, better results may be obtained in some cases by connecting the lead from condenser (15) to resistance (11), instead. It is of the utmost importance to use high-grade tubes of uniform rated characteristics. The various resistances specified, were selected to have the closest value possible to actual requirements. However, they have to be reduced (using the adjustment provided) to the following values: resistance (11) to about 320 ohms; resistance (12) to 950 ohms; resistance (14) to 1,400 ohms; resistance (18) to 2,600 ohms.

### PROBLEMS OF EMPIRE BROADCASTING SOLVED

(Reprinted from Wireless World, London, England).

One by one the obstacles which have stood in the way of the establishment of Empire broadcasting have been overcome, until now we learn that the last excuse for delay, namely, the problem of funds, has been solved by the Colonial Conference. We understand that the establishment and maintenance of an Empire short-wave station at an approximate cost of £23,000 (\$115,000 approximately) has been agreed to, the cost to be borne by the Colonial Office, which will also be responsible for the maintenance of the station, whilst the British Broadcasting Corporation will staff the station and conduct the transmissions.

The British Broadcasting Corporation, it will be remembered, had recently expressed their willingness to run the station, provided that out-of-pocket expenses were met, and it is therefore assumed that the sum now agreed upon to be furnished by the Colonial Office is intended to cover these out-of-pocket expenses in connection with the erection and maintenance of the station. Reuter's News Agency, we understand, has been approached, and has agreed to provide a special news service for the Empire station at an annual cost of £3,000 (\$15,000). No other programme expense is likely to be involved, as the B.B.C. have undertaken to relay their programmes day by day.

This is exceedingly welcome news, and, since the final decisions have now been taken, there should, we think, be no further delay in the establishment of the station.

The transmitter will in all probability be erected in the neighborhood of Daventry, England, in proximity to the existing B.B.C. stations there. As soon as the station is erected it will no doubt take over the service at present being conducted through 5SW at Chelmsford. Just how long it will be before the station is ready for service must largely depend upon the enthusiasm shown by the B.B.C., but in view of the generous attitude which they recently adopted towards the scheme as soon as they learnt that it had strong support from the representatives of the Colonies meeting in London, England, we do not think that the period for the erection and inauguration of the station is likely to be prolonged.

#### Twenty-four Hour Programmes?

We have previously been informed that the aim of the B.B.C., in the event

of funds for the cost of the station being provided, would be to conduct a twenty-four hour service. Just how this is going to be arranged is not clear at present, but no doubt the B.B.C. will find some means of overcoming any difficulty in the way of conducting such a continuous transmission. We may perhaps expect that the first efforts in this direction may take the form of recording the day's programme and re-broadcasting from the record during the night hours. Such an arrangement would provide the twenty-four hours' continuous programme and enable listeners in all

parts of the world to participate. How unanimous must have been the support given to Empire broadcasting by the Colonial Conference is indicated by the fact that it is understood that the question will not be raised again at the Imperial Conference, as it is considered that the matter has been virtually settled.

After so many years of hoping and urging for the establishment of an Empire service, it is intensely gratifying to learn that the accomplishment of the ideal now approaches fulfilment. The value of an Empire (Continued on page 15)

## What About Radio Insurance?

It's a simple matter and inexpensive too—just equip your receiving set with Hydra Condensers.

Hydra Condensers protect your tubes against high tension currents—the insulation resistance averages more than 1,000 megohms per microfarad.

There's no condenser like the Hydra for permanent protection against H. T. Currents. Hydra Condensers are used by the foremost radio manufacturers in Canada and Europe. Try Hydra Condensers once and you'll always use them.



## HYDRA CONDENSERS

SOLD AT POPULAR PRICES BY ALL GOOD RADIO DEALERS.

**LOUIS HOLZMAN LIMITED**  
414 New Birks Building - Montreal

## CANADIAN PACIFIC RADIO HOUR

From Banff Springs Hotel

Friday Nights,  
10 to 11 p.m.

Over an all Canadian  
Network

"Cheerful and Good"

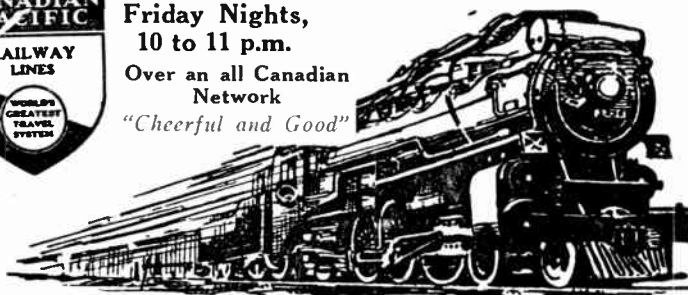

## Jensen Radio Announce Midget and Concert Jr. Models

Two new electro-dynamic speaker units are announced by the Jensen Radio Mfg. Co., Chicago, Ill. These supplement the line that was announced in June and displayed for the first time at the R.M.A. trade show held at Atlantic City early that same month.

Designated as the Jensen Midget and Jensen Jr., these new models have been designed for use with automobile and the so-called mantle or midget type radio receivers and for similar purposes requiring a speaker of extreme compactness permitting of its installation where only limited space is available.

The Midget, designed as Model D-11 by the manufacturer, has all the exclusive features incorporated in this company's speakers of the larger sizes. Its cone diameter is  $7\frac{1}{4}$  inches. It can be mounted in a space  $8\frac{5}{8}$  inches wide by  $4\frac{3}{4}$  inches deep.

According to Peter L. Jensen, who is responsible for the design of these two new units, the magnetic structure of the Midget reproducer is exceedingly high in its efficiency, with the field coil dissipating a minimum of energy yet at the same time having an unusually high degree of sensitivity.

This new unit is suitable for operation with amplifiers using type 171 or 245 tubes connected singly, in parallel or in push-pull.

The second new unit is the Concert Jr. and is being offered to the trade in answer to the demand for an electro-dynamic speaker of small size yet having a degree of brilliance, sensitivity and uniformity of response at all frequencies comparable with units of much larger size.

In the Concert Jr. or Model D-10 as it is designed, an entirely new design of moving coil assembly is used. While this unit can be installed in the same size space as required for the Midget its construction is more sturdy. It can be mounted either through the cone housing or by means of a supporting bracket which is an integral part of the unit.

Both of these new units are to be available in types for operation with both AC and DC current. The first units produced were for 90 to 110 volt DC operation. Units for 110 volt AC and 6 volt DC operation are also available.



This is an illustration of the new Jensen Midget Electro-Dynamic Speaker, Model D11.



CANADA

## WARNING TO USERS OF RADIO

**All Radio Receiving Sets  
MUST be Licensed**

Penalty on summary conviction is a fine not exceeding \$50.00

**LICENSE FEE \$1.00 PER ANNUM**

Licenses, valid to 31st March, 1931, may be obtained from: Staff  
Post Offices, Radio Dealers, Radio Inspectors, or from  
Radio Branch, Department of Marine, Ottawa

**A. JOHNSTON, Deputy Minister of Marine**



## YOUR Monthly MAIL BOX

Correspondence is invited on any matter pertaining to subjects in this magazine. Tell us what you want to know—how you like Radio News or why you don't like it. All letters will be answered in this section. Address "Mail Box," c/o Radio News, Technical Section Under Direction of J. C. Wilson, President, Radio College of Canada, Ltd.

Contributors to this Dept. are hereby notified that in future a charge of 25 cents will be made for each personal reply requiring a diagram. Contributors are also reminded that no query can be answered unless accompanied by a 2 cent stamp. Owing to the volume of correspondence these rules must be rigidly enforced.

### LACK OF DISTANCE

H. Butterworth (Muskoka). — Received your letter of information and thank you. I am enclosing a rough sketch as per request and I would like to say that I found a broken center tapped resistors and I now have the hum under control but now I notice that the set has no pick-up and I can only get CFRB which is the strongest here and I can't get CKGW and can only hear the signal very weak. I took out the 171 power tube and replaced it with a 112A but it is not better and I am very disappointed and will appreciate it very much if you can help me as I have not much chance in this hospital. When I connect the aerial to the ground post it gives better results than when connected right, but the set seems to be very weak.

In my last letter I asked you about parts and 226 and 227 tubes and sockets so please let me know if you have any for sale and the price of same.

#### Reply

There appears to be no reason why your set does not bring in distant stations, unless perhaps the tickler coil is reversed. Try reversing the lead-ins going to the plate and the transformer, and also try disconnecting the .002 condenser. Provided the tubes are all right, and there are no mistakes in the wiring up the circuit, we see no reason why it should not work correctly.

### SHORT-WAVE CONVERTER

A. C. Birch (Winnipeg, Man.)—I have been interested in your reprint from QST about the short-wave converter. I believe this should be a fine thing to have, and wrote QST some time ago to ask if they could give another article with specifications of metal base, and instructions for building the set, but in reply, advised me that they did not do that with their magazine. So I am writing to ask if you could give (a great majority of your readers I feel sure would welcome it), us an article with plans, and if possible, the name of one of your advertisers who could supply the parts, especially the coils.

I have a Silver radio, and would like to know whether the voltages obtained from the 1st radio F. tube would be satisfactory to use in the converter—an appliance can be bought that supplies the duplicate voltages of the socket it is placed in, called a "tubeadapter," so that the 1st R.F. tube could still be used.

Hoping you will be able to give us another article on this converter.

#### Reply

It would be possible to use an adapter which plugs in the radio frequency stage of the set if the screen grid tube was used in that stage. We will be publishing a full description of a short wave receiver in an early issue.

### BLUE PRINT WANTED

C. Westerlund (Vancouver, B.C.) — I would be very much obliged if you would forward me by return mail, 1 Blue Print of a 6-Tube Radio.

#### Reply

Replying to your letter of the 11th of July, you have not said what kind of a Blue Print you want. On receipt of this information, together with the usual fee of 25c., we will be glad to send it to you.

### SHIELDED LEAD-IN WIRE

R. E. Prest (Halifax, N.S.)—I notice in recent issues of your magazine, articles by members of the Cornish Wire Co.

In your latest issue the article was on "Antenna" and "Lead-in" wire.

Would you kindly furnish me with information as to where I can purchase this wire in Canada, and if possible get me a price on same.

#### Reply

You can purchase shielded lead-in wire from the Wentworth Auto Supply Limited, Toronto, Hamilton or Montreal.

### LONG-DISTANCE CONVENTION WITH AEROPLANE

Telephonic communication between an aeroplane flying above Buenos Aires and the White Star liner Majestic while nearing the English coast was successfully accomplished over a distance of about 8,000 miles. From Buenos Aires wireless connection was made with Madrid, thence by land-line to France, and by cable to Rugby, where wireless was again employed for establishing communication with S.S. Majestic.

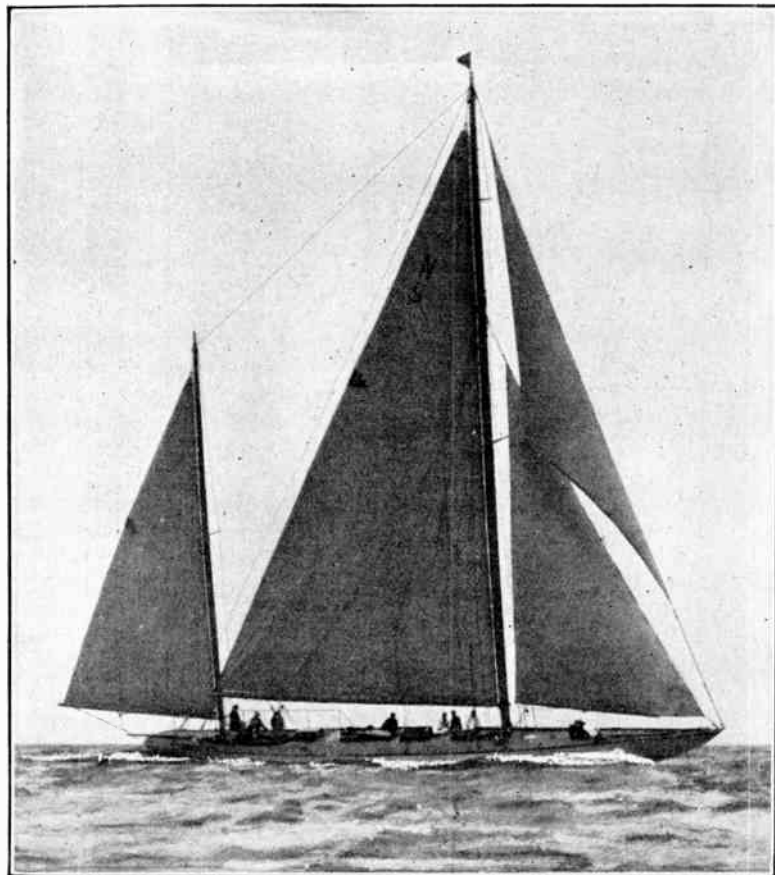

The Nonchalant, owned by Major James E. Hahn, President of De Forest Crosley Radio Company Limited, Toronto. The Nonchalant is a seventy-two foot auxiliary yawl, Hereshoff built, which is sailing off the Atlantic coast this year. Major Hahn will bring this craft into Canadian waters next year under the colors of the Royal Canadian Yacht Club. It will be a decided addition to the Canadian sailing fleet, being one of the largest sailing yachts in Canada.

(Continued from page 5)

Clough-system tuned transformer of approximately 1:1 ratio. The primary circuit of this transformer is resonated to provide an overall a.f. curve flat to 30 cycles, and thus insure absolutely faithful reproduction. As no d.c. plate current is allowed to flow through the Clough a.f. transformer primary (all d.c. being confined to the plate resistor), all possibility of hysteretic distortion is eliminated; that is, distortion due to unsymmetrical magnetization of the transformer core steel. This is a valuable feature, definitely contributing to purity of reproduction, as all who have used the Clough audio system can testify.

For phonograph record reproduction, a jack is placed on the left end of either type of set chassis, which allows a magnetic record pickup to be connected into the detector grid circuit. So plugged in, the a.f. pickup output is amplified by the '24 detector tube (which under such conditions acts as an a.f. amplifier) before it reaches the regular a.f. channel of the receiver thus insuring ample volume together with unusually clear and beautiful tone quality.

#### True Overtone Control

Theoretically, if a radio receiver reproduces all audio frequencies from below 100 cycles to 4,000 without appreciable discrimination, it would be practically perfect, and would leave nothing in the way of tone to be desired. Actually, such is not the case, and such a receiver would not satisfy all tastes nor all conditions of home acoustics. In the matter of taste only, it has been found that the majority of listeners have a distinct aversion to really faithful treble reproduction, and definitely prefer accentuated bass, or slightly suppressed treble. Two factors account for this—high notes are felt, rather than heard, so that a loud high tone really causes irritation, or even pain, and the fact that static and interfering noises are most prevalent on the higher audio frequencies. It was found, in connection with the 1929 Silver Radio, that fully 90 per cent of all listeners usually preferred to listen with the overtone switch in the "low" position where notes above 2,000 cycles were appreciably subdued. Despite all theoretical contentions to the contrary, the facts definitely establish the desirability of manual tone control—or, more accurately, overtone control—on radio receivers which are initially capable of reproducing a full a.f. range, something, incidentally, which most sets not possessing such a control do not do. The overtone control of the 1929 Silver has, there-

fore, been retained in 1930, and improved so that instead of there being only two tone choices at the listener's disposal, a continuously variable range from very deep to very brilliant tone may be had at the turn of a knob.

Electrically, the overtone control takes the form of an a.f. filter consisting of a 10,000 ohm rheostat and a 0.1 mfd. condenser in series shunted across the primary circuit of the a.f. transformer. As the rheostat is cut out, the higher tones are increasingly suppressed—yet the listener who really desires tone reproduction that faithful which can be had only through full coverage of the a.f. range from below 100 cycles to 4,000—the full useful musical and voice range—has only to turn the knob so as to cut in the whole rheostat.

(Continued from page 7)

matched butt walnut front, back and top, and may consequently be placed anywhere in room.

"Model 76 Highboy with sliding doors, 45 $\frac{3}{4}$  inches in height, 26 inches in width, and 16 $\frac{1}{4}$  inches in depth. Finished in hand-rubbed walnut with matched butt walnut on doors and front panels.

"Model 75 Radio-Phonograph combination, 40 $\frac{1}{4}$  inches in height, 26 $\frac{3}{4}$  inches in width and 17 inches in depth. Finished in hand-rubbed American walnut with matched butt walnut doors and panels; top is piano-hinged with automatic support. There is also an ample record compartment.

"The new set makes use of seven A. C. tubes and one rectifying tube—three screen-grid 24's; two 27's; two 45's power tubes and an 80 rectifying tube. Other features are four condensers; posts for short and long antenna; dual volume control acting both on amplification and input, thus giving the best operation at a point near or far in relation to the station. The new circuit is specially improved for equalizing amplification of the entire broadcasting range. The new special detector circuit makes for far more flexible volume and increased clarity at full volume. A long-distance switch is included in the new set.

"In addition to the standard 60-cycle, A. C. set, there will also be a 25-cycle set, a D.C. set and a battery set."

#### INSTABILITY ON LONG WAVES

When a set with an S.G. high-frequency valve or valves is instable on the long-wave band, but performs satisfactorily when medium wavelengths are being received, the

trouble is generally attributed to the action of H.F. currents in the L.F. amplifier. It is a fact that the usual arrangements for separating H.F. and L.F. components in detector anode circuits become less and less effective as wavelength is increased, and so this conclusion is often justifiable. But it must not be forgotten that the trouble may almost equally well be due to falling-off in the effectiveness of "decoupling" devices; the working value of the resistances used in these systems remains constant irrespective of wavelength, but the reactance of the associated condensers increases rapidly with increase of wavelength. Consequently, the filtering action of these devices becomes less effective as wavelength is increased, and long-wave instability may quite possibly be due to stray coupling brought about by voltages set up in the common source of anode current supply, whether it be a battery or an eliminator. The remedy, of course, is to fit considerably larger bypass condensers.

#### A QUICK CONDENSER TEST

Various simple methods of testing the insulation of fixed condensers, and even of forming a rough idea as to whether their capacities are substantially correct, have been put forward, but unfortunately most of them take a certain amount of time to put into execution. Now in a modern mains receiver there may be about two dozen of these components, in various capacities, and an extended test of each of them is a lengthy business. A good idea as to the insulation resistance of a condenser may quickly be obtained by noting the effect of making successive contacts across its terminals when using the phones-and-battery method. On first closing the circuit, a click, depending in intensity on the capacity of the condenser, will be heard, but when it is fully charged to a potential equal to that of the testing battery, no click should be audible.

If clicks of approximately the same loudness occur at each contact, it can definitely be assumed that the insulation resistance of the condenser is at least poor, or even that it has completely broken down. Of course, before making the test, one should assure oneself that there is no parallel path for current, and if necessary disconnect one of the terminals.

### "NEW FLECHTHEIM CONDENSERS"

Among the several new types of condensers introduced by the well-known A. M. Flechtheim & Co., Inc., of 136 Liberty St., N.Y.C., manufacturers of Flechtheim Superior Condensers, is type HS. This new condenser is exceedingly remarkable for its small physical size and high working voltage, the condenser having a rating of 1,000 v. D.C., or 660 rms. rectified A.C.



Features of this new condenser are such that it fulfills a long felt need in aircraft receivers and transmitters and in portable radio outfits.

The Flechtheim Company also announces a new 5,000 v. D.C. (3,300 rms. RAC) transmitting condenser which has proved its dependability in dozens of broadcast stations.

The new 1930-1931 Flechtheim fall catalogue is now available and will be gladly sent to anyone writing to them at the above address.

### UNIQUE RADIO TEST MADE IN TENNESSEE CAVERNS

A unique demonstration of the uncanny ability of radio waves to penetrate the depths of the earth and even pass through solid rock was recently held at Chattanooga, Tenn.

A Crosley radio was installed in Lookout Mountain cave by the local distributor, where during a period of ten days, more than 5,000 people had an opportunity to listen to this remarkable test.

Lookout Mountain cave is less than three miles from the downtown business section of Chattanooga and one of the greatest wonders of the South. It is really a series of weird caverns discovered many years ago, but only recently made easily accessible for the public.

Queer and grotesque formations carved in solid stone present themselves at every turn in the caverns, some of them being about one

thousand feet below the surface. Glittering stalactites blaze in front of fluted columns. Draperies in broad folds and a thousand tints are beautified by indirect lighting.

When the visitor enters King Solomon's temple he finds an open plateau nearly 400 feet long, 60 to 80 feet wide and from 200 to 250 feet high. This mammoth underground temple is divided into giant twin domes, separated by a projection of rock on either side. At the end of the temple comes the climax of the strange handiwork of nature where an underground river pours its stream of crystal pure water from 145 feet above into a beautiful lake.

When the radio was operated about five hundred feet underground, it was possible to tune in on a large number of stations with good reception. At one thousand feet reception of the local stations continued good but there was some difficulty with distant stations. The tone of the instrument under such unusual conditions caused much favorable comment from the thousands of visitors during the ten-day demonstration.

### DOES YOUR RADIO REALLY FADE?

Listeners-in frequently complain about fading, to the consternation of broadcasters. For if there is one thing that starts commercial broadcasters worrying, it is the mention of fading, which suggests loss of listeners-in, the dwindling of programme sponsors, and the loss of income with which to carry on.

Recently, broadcasters have looked into the matter of fading and have found that many such complaints are not always due to true fading. In many instances, so-called fading is nothing more than line voltage fluctuation, which causes the volume as well as the tone of electric sets to vary over wide limits. Since the line voltage in some sections varies from 85 to 140 volts, or far beyond the 5 per cent plus or minus 110-volt average, it must be apparent that the volume and the tone of the electric receiver thus operated will vary accordingly.

Before accusing the broadcaster of fading signals, it may be well, therefore, to check up on the line voltage which, in most instances, will prove the real source of fading. The simplest means is to include an automatic line voltage regulator either as a built-in feature found in the more advanced radio sets, or as an accessory. Such a device, while low in cost, serves not only to provide uniform radio re-

ception, but also increases the life of the tubes several fold. The device selected should be automatically regulated to meet changing line voltage, and not of the fixed resistance type which merely reduces line voltage by a set value at all times and therefore offers no compensating effect when the line voltage drops below the normal value.

### YOUR EARTH CONNECTIONS

The essential points of a good earth connection are, firstly, that thoroughly good contact should be obtained with the ground and, secondly that the connecting lead between the "earth" and the receiving set should be as short and direct as possible and consist of fairly stout wire or stranded conductor, i.e., having low electrical resistance. Both conditions are met when a connection can be made to the incoming water-pipe by means of a reasonably short copper wire, say of 16 or 18 S.W.G.

Gas pipes should not be used as an "earth."

### NO NECESSITY TO TUNE

The Hague Telephone Administration for some months past has been experimenting with a new system for the distribution of wireless entertainments to its telephone subscribers. Over 400 receiving instruments have now been fitted with the new device, and by pressing a button the subscriber is given the choice of three wireless programmes which may be received on headphones or loud-speaker. At present the telephone system is in direct connection with the Hilversum and Huizen transmitters. The alternative to these is called a cocktail programme, consisting of excerpts of Dutch and foreign entertainments. The instrument is so attached to the existing telephone that the wireless transmission is automatically cut out in event of an incoming call being put through, and restored, if so desired, at the end of the conversation.

(Continued from page 11)

broadcasting service can scarcely be over-estimated, and perhaps no more opportune time could be found for inaugurating such a service than the present, when so much attention is focused upon Imperial issues and the need for closer co-operation in inter-Empire trade.

# Learn in Toronto. The Centre of Canada's Radio Industry



**Start Now and Prepare for a Well  
Paid Position in the Fall**

---

*Special Arrangements Made for  
Out of Town Pupils.*

---

*Write Now to President*

**Radio College of Canada Limited**  
310A Yonge Street, Toronto