

...ON WITH PHONE SERVICE TO BE TRIED IN GERMANY

RADIO

REG. U.S. PAT. OFF.

WORLD

The First National Radio Weekly

651st Consecutive Issue Thirteenth Year

PICTURE DIAGRAMS OF TWO NEW TYPE SIGNAL GENERATORS

7-Tube All-Wave
A-C Superheterodyne

A DELUXE TUNER OF ORIGINAL DESIGN

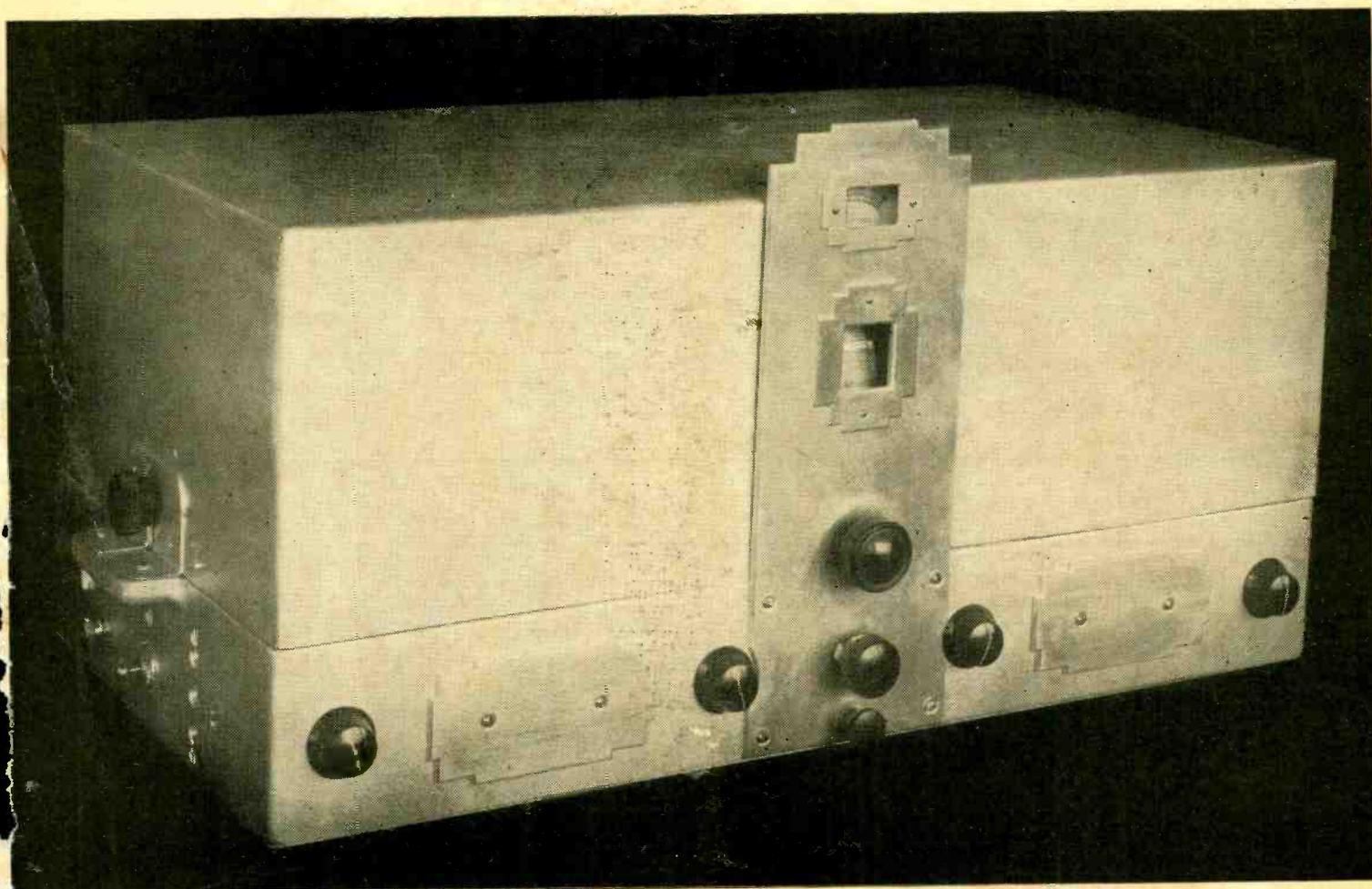

Expert mechanical work, painstakingly done, plus a fine circuit, comprise this masterful tuner. See page 15.

RELAXATION
OSCILLATORS
DISSECTED

SEPTEMBER 15th

1934

TECHNIQUE
OF THE WEEK
(Keep Abreast of the News)

HOW CENTIMETER
WAVES ARE SENT
FROM SMALL TUBES

PRICE, 15c PER COPY

New Bernard Signal Generators

Automatic Harmonic-Confusion Eliminator, Amazing Invention, Applied to 100-200 kc Fundamental for Coverage to 40 mc.

COMPLETE elimination of confusion due to the use of harmonics is achieved in the Model 334 Signal Generator, designed by Herman Bernard. His unerring, amazing method enables not only peaking all receivers, 100 kilocycles to 40.6 megacycles, but affords readings of wavelengths in meters, 3,000 meters to 10 meters. Besides being an all-wave, constantly-modulated Signal Generator for service work, it is an All-Wave Station-Finder, enabling determination of both frequency in kilocycles or megacycles, and wavelength in meters. Bernard Signal Generators are the only devices offering this double service of frequency and wavelength measurements.

The conquest of the formerly confusing harmonic problem is a milestone in radio progress. The Bernard Automatic Harmonic-Confusion Eliminator introduces a new, scientific principle, making Model 334 almost a magical instrument.

The fundamental frequencies are 100 to 200 kc—excellent spread-out—1 kc. dial separation. The frequencies are imprinted right on a new type airplane dial, hence are direct-reading. Bernard Signal Generators are never of the "unfinished" type that requires consultation of charts. Besides, dial scales can be read more accurately than charts and save your eyes.

The accuracy is 1%, for fundamental and harmonics. That means the calibration stays put.

The top tier on the dial reads 100 to 200 kc. (1 kc. separating bars); the second tier 200 to 400 kc. (5 kc. separation); the third tier 400 to 800 kc. (bars still 5 kc. apart), and the fourth tier 800 to 1,600 kc. (10 kc. separation). Thus are all intermediate and broadcast frequencies covered.

The Automatic Harmonic-Confusion Eliminator, guides the positions of the pointer for 300 to 1,600 kc. in 100 kc. steps. Higher frequencies (lower waves) are most accurately determined by a simple, infallible calculation.

The extreme lower scale applies the Automatic Harmonic Confusion Eliminator to frequencies from 1.6 mc. (where previous coverage left off) to 20 mc., most of the dial span registering these high frequencies in steps of 200 kc. So besides being an eliminator of confusion, the method is an accurate register of frequencies.

The text tier—second from bottom—is for fundamental wavelengths, 3,000 to 1,500 meters, and may be used directly for that range, and with the slight mental calculation for low waves to 10 meters or frequencies to 40.6 mc.

The remaining tier gives the positions for popular intermediate frequencies, 480 to 250 kc. for completely and infallibly registering the desired frequency so nobody could possibly make a mistake, or be fooled by an harmonic and requiring no calculation.

For determining frequencies, 100 kc. to 40.6 mc., many measurements are of the direct-reading, non-computation type. Whenever for high frequencies any computation is required it is either merely subtracting one small number from another or multiplication of two small numbers. These numbers are read accurately from the dial.

The use of the whole device is simple in the extreme, and explained in the circular supplied with Model 333. There is no switching. There are no moving adjuncts.

The r-f oscillator tube is a 34. The Signal Generator works on 90-125 volts, a-c (any commercial frequency), d-c or batteries. On d-c or battery use a neon tube is the modulator. On a-c the line frequency (hum) is the modulation, heard only at resonance. The r-f oscillator is unusually stable for all frequencies or wavelengths and is free from detuning effects due to coupling it to the measured circuit. The output is electron coupled. So is the modulator to the oscillator.

Model 334 has an attenuator with switch attached, and is supplied equipped with tubes, ready for operation. Model 334 Bernard Signal Generator, complete with tubes, instruction sheet (shipping weight, 5 lbs.), list price, \$24. Net price, \$12.00 Model 334K (complete kit, instructions; less tubes). List price, \$20. Net price, \$10.00

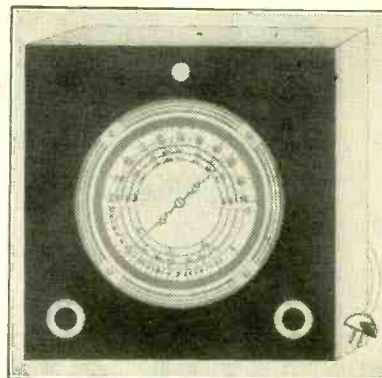

The Model 334 Signal Generator, a service instrument, may be used also as a Station-Finder, without any tampering with the receiver. Not only does Model 334 enable telling whether a station is on the air, but also what is its frequency and wavelength (both).

Junior Model

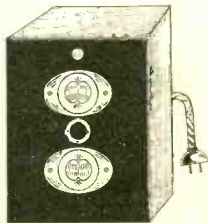

THE Junior Model Signal Generator, No. 335, has fundamental frequencies of 108 to 200 kc., calibration bars 1 kc. apart, and utilizes the same principle of harmonic-confusion elimination as does the Model 334. The scales read 108-200 kc. (1 kc.); higher i-f; 2,700 meters to 1,500 meters; automatic harmonic counter, 2.0 to 20 mc. The dial is direct-reading in frequencies and wavelengths of

the fundamental, as are all Bernard Signal Generators, and besides dual use may be enjoyed, for testing purposes, 108 kc. to 20 mc., 2,700 meters to 15 meters, and for station-finding in the same range. This instrument is particularly suitable as a Station-Finder for those who do not expect to put the instrument to any or much use as a service instrument, lining up receivers, etc. Hence this model is not equipped with an attenuator. The accuracy is 1 per cent. Model 335 uses a 30-tube and is for 90-125 use, a.c. (any frequency), d.c. or batteries. On d.c. or batteries there is no modulation. List price (complete with tube, instruction sheet, ready to be operated; shipping wt., 3 lbs.), \$13.00. Model 335, net price (complete, wired) \$6.50

Model 335K—Complete kit for above, instruction (less tube), list price, \$10.50. Net price, \$5.25

Switch-Type Instrument

IMAGINE a Signal Generator that enables measurement of frequencies from 83 kc. to 99.1 mc. and wavelengths from 3,010 meters to 0.1 meter.

In several services low frequencies are commonly given only their wavelength equivalents, and for very high frequencies this is true likewise. So a Signal Generator, that enables determinations in both wavelengths and frequencies is the thing. That service is what the new Bernard Signal Generator Model 333 renders.

Besides the more general purpose of lining up superheterodynes at intermediate, broadcast and short-wave levels, and peaking tuned-radio-frequency sets, it may be used as an all-wave Station-Finder, constantly modulated. Dual Measurement and Combination Use make this Signal Generator most valuable.

The fundamental frequencies and wavelengths are direct-reading. There are no charts to strain the eyes. The dial is accurately calibrated and the Signal Generator accurately adjusted. These fundamentals are: 83 to 99.9 kc. (1 kc. separation); 140 to 500 kc. (5 kc. separation); 540 to 1,600 kc. (10 kc. separation); 1,620 to 4,500 kc. (50 kc. separation); 3,010 to 3,600 meters (25 and 50 meter separation).

The bands are selected by turning a front-panel switch. There are four switch stops. The low-frequency band and the wavelength band cover the same range, the same stop being used, though there are two scales for this band, wavelength and frequency.

Any frequencies or wavelengths as listed above are present as fundamentals and are read directly.

A new method, simple to apply, enables measurements from 4,500 kc. to 99.1 mc., also wavelengths from 3,010 meters to 0.1 meter. The extension of the fundamental ranges is accomplished by a startling method that opens up new possibilities of extensive and accurate measurements.

Model 333 Signal Generator, for 90-120 volts a.c., d.c. or batteries; designed by Herman Bernard, accurately calibrated and adjusted, for all-wave service, 83 kc. to 99.1 mc., 3,600 meters to 0.1 meter; equipped with output attenuator, on-off switch, modulation switch for d.c. and battery use; Chromium-plated control and band-index scales, positive-contact, low-resistance band-selector switch, a.c. cable and plug, black wrinkle-finish shield cabinet, with 34 tube, neon tube, and instruction sheet included. Ready for immediate use.

Model SG-333 (shipping weight, 7 lbs.)

NET PRICE \$19.95

Model SG-333K, instructions (less tubes), complete kit; list price, \$32.00. Net price \$16.00. List Price \$40.00

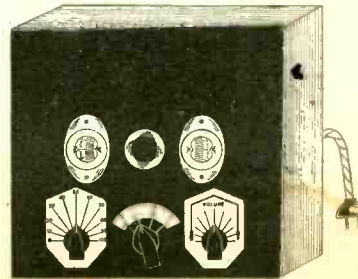

Release date of these three new instruments October 15th.

DIRECT RADIO CO., 145 West 45th Street, New York, N. Y.

ROLAND BURKE HENNESSY
Editor
 HERMAN BERNARD
Managing Editor
 OFFICERS
 Roland Burke Hennessy
President and Treasurer
 M. B. Hennessy, *Vice-President*
 Herman Bernard, *Secretary*

RADIO REG. U.S. PAT. OFF. WORLD

The First National Radio Weekly
 THIRTEENTH YEAR

Price, 15c per Copy; \$6.00 per Year by mail. \$1.00 extra per year in foreign countries. Subscribers' change of address becomes effective two weeks after receipt of notice.

Entered as second-class matter March, 1922, at the Post Office at New York, N. Y., under Act of March 3, 1879. Title registered in U. S. Patent Office. Printed in United States of America. We do not assume responsibility for unsolicited contributions, although careful with them.

Vol. XXVI

SEPTEMBER 15th, 1934

No. 1. Whole No. 651

Published Weekly by Hennessy Radio Publications Corporation, 145 West 45th Street, New York, N. Y.

Editorial and Executive Offices: 145 West 45th Street, New York

Telephone: BR-yant 9-0558

Design of a 7-Tube Super All-Wave Model Being Built—Continuing Reports on Progress

By Herman Bernard

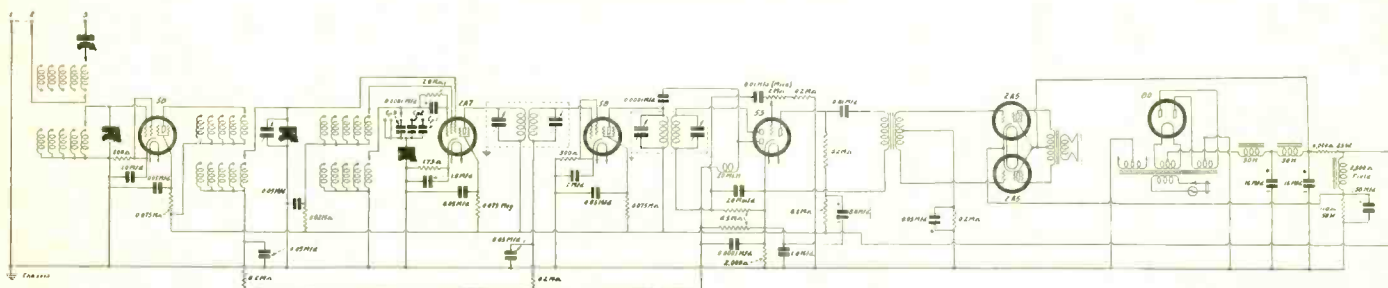

A seven-tube all-wave superheterodyne that is now being subject to experimentation. The idea is to express what the designer intends to do, and then, on the basis of experience, report what actually has to be done. Sometimes the two differ greatly.

A CIRCUIT designer first draws a diagram, then tries it out, then amends it as circumstances require, and perhaps the process of improvement never stops until the model is discontinued.

So here is such a diagram. Admittedly the circuit has not been built. But the process of presentation is being reversed, so that the intended circuit is shown, the construction will be undertaken, and such changes made as required, and all these will be reported.

The circuit is that of a seven-tube all-wave superheterodyne, using switching for band shifting. All the design work on such a receiver could scarcely be completed by one man in less than six months, therefore it may be assumed that experience gained in other endeavors is brought into play. This is naturally so.

Antenna Inputs

Therefore the present intention is to discuss the theory of the circuit, and as there will be plenty of time, readers are invited to send to the author such comments as they desire, and it will be quite possible to include any extra requirements that the correspondents convince the author should be adopted.

First, let us consider the antenna.

There are three binding posts, 1, 2 and 3. For a doublet antenna Nos. 2 and 3 are

used. For a Marconi antenna, the more usual type, or so-called grounded antenna, a shorting strap of wire is put between Posts 1 and 2. This is now more or less conventional.

The series antenna condenser is included in case the lead-in and coupling system do not provide any tuning facilities. So far as the author knows, for effectiveness over a wide span of frequencies, some impedance adjustment is necessary. A few of the noise-reducing antenna systems for all-wave coverage have switching to take care of this in a good way, but the series antenna condenser will be of use even so, in the author's estimation, as from previous experience stations not otherwise heard well sometimes are brought in exceptionally clearly when this condenser is properly set to its non-critical adjustment.

Screen Resistors

Because of the provision for dipole connections, the antenna coupler is a transformer, step-up ratio, primary to secondary, and feeds into a radio-frequency amplifier tube, a 58. This tube has suppressor connected to cathode, the more selective method. The bias is orthodox. A 300-ohm resistor is used, but the condenser across it is 1.0 mfd. instead of the smaller values usually found. The reason for the higher capacity is that

it eliminates the necessity for r-f choke and bypass condenser in the plate return leg.

It will be remembered that all the space stream current unites in the cathode, and therefore feedback is reduced to next to nothing if the capacity is made as large as this. The biasing resistor should be non-inductive, meaning practically a carbon or metallized type, not wire-wound. The 1.0 mfd. condenser also may be non-inductive preferably, but this point may not be so serious.

The screen voltage is just right, around 100 volts, if the plate voltage applied is 250 volts and the limiting resistor in the screen circuit is 75,000 ohms. Not until the suppressor type tubes came out did it become good practice to supply the screen voltage this way. The reason is that the total plate current, in suppressor type tubes, depends on the screen voltage rather than on the plate voltage. Otherwise expressed, the suppressor makes the limiting resistor acceptable. The condenser bypassing the screen resistor need not be greater than 0.05 mfd.

Image Interference Reduced

There is no trimmer condenser across the first section of the three-gang tuning condenser because the series antenna condenser, for short waves, serves this purpose suf-

(Continued on next page)

(Continued from preceding page)
ficiently, being in reality a control equivalent to a parallel condenser, because affecting the antenna capacity which is in parallel with the primary, and because of the reflected effect upon the secondary of this primary capacity and its variation.

The foregoing disposes of the t-r-f stage, which is practically a necessity, due to the relatively low intermediate frequency used, 465 kc. Soon enough, or too soon, the frequency difference between the carrier and the oscillator frequencies becomes small, hence unless there is a stage of t-r-f there will be considerable interference due to insufficiency of selectivity. This interference is of a type peculiar to superheterodynes and is called image interference. It is due to any particular frequency of the local oscillator yielding possibility of response to two frequencies in the antenna circuit: one is the carrier lower than the local oscillator frequency, by 465 kc, and the other is the carrier higher than the local oscillator, by 465 kc. So the images appear apart on a frequency basis by an amount equal to twice the intermediate frequency. That is, the intended carrier and the image are separated by 930 kc in this instance.

The Local Oscillator

Now we come to the mixer. This is a pentagrid converter tube, the 2A7. It unites the carrier and local oscillator frequencies by electron coupling, which is practically independent of frequency, yet it must be remembered that at the high frequencies the losses increase—a general statement applicable to all sets—and therefore what is to be mixed is of lower amplitude. This has about the same effect as if the amplitude were fixed and the coupling reduced at higher frequencies. Therefore the electron-coupled method is satisfactory, as working in the right direction.

The 2A7 has eight connections brought out, two for heater, one for oscillator grid, another for oscillator plate (triode), one for control grid of the pentode, another for screen, which is a combination of two elements, and the last for pentode plate. There are seven base connections and an overhead cap for control grid of the pentode.

The oscillator is of the grid-leak-condenser type. When a limiting resistor is put in the plate circuit the stability is greatly improved. This is shown as 20,000 ohms, bypassed by 0.05 mfd. The leak was selected at 2.0 meg. and the grid condenser at 0.0001 mfd. because these values were found to afford clean zero beats when the oscillator was coupled to a receiver responsive to the oscillator frequencies, and stations tuned in on the receiver. A clean beat is suggestive of quality and stability.

Better H-F Oscillation

Instead of being returned to cathode, the oscillator grid is connected through the secondary to ground, so that there is what seems to be a negative bias. In fact, however, the grid runs positive. First, the bias is low, arising from 175 ohms, and, second, the oscillation amplitude is higher than the bias, and in the opposite direction. When it is remembered that when grid current flows an extra drain is put on the emission unit, here the indirectly-heated cathode, return the negative instead of to zero limits the grid current somewhat, and affords better oscillation at the highest frequencies tuned in.

The biasing resistor has to be pretty low, otherwise the conversion conductance is reduced. Under some circumstances the bias ought to be higher than under others, particularly to check second-harmonic distortion, and the form of interference due to a second harmonic of the local oscillator permitting reception of a relatively high-frequency station at a low-frequency setting. The pre-selection considerably atones for this, but special precautions in biasing help just as much. Therefore the bias on the pen-

tode is controlled by the automatic-volume-control circuit.

What Bands?

The a-v-c, by the way, is somewhat limited intentionally, as it is too easy to overdo this virtue and have too greatly diminished sensitivity. All a-v-c action everywhere is at the expense of sensitivity. But such control does correct somewhat for forms of fading, and it enables gauging the audio amplifier to a more even performance.

There are five bands covered. The trimming could not be done with sufficient closeness and permanency by usual methods of including compression type condensers, as these do not hold their settings. And since the tuning of the r-f stage and input to the modulator does not determine the frequency, but rather the sensitivity and in important regards the selectivity, a manual trimmer is put across the input to the modulator. Therefore if the dial scale is frequency-calibrated, the calibration is in no way affected by these manual controls. And the controls should be there for maximum performance.

If the tuning starts at the low-frequency end of the broadcast band it will reach from 540 to 1,700 kc, and as overlap is to be provided, this ratio may be treated at 3-to-1 for that purpose. Certainly the broadcast band has to be padded in the local oscillator (Cp1), and the intermediate short-wave band as well (Cp2). How much farther to go is a matter of dispute. The spectrum from 4,760 to 14,580 kc might be padded, too, as shown (Cp3), the next two bands needing no padding, though they are not to be carried to what might be termed their illogical conclusions. With five bands, starting at 540 kc, the ranges would be 540 to 1,620 kc; 1,620 to 4,860; 4,860 to 14,580; 14,580 to 43,180; 43,180 to 137,540. Of course, these ultimate frequencies are ridiculously high and the circuit surely would not function there; moreover, if it did, the dial indicator alone would cover a span of thousands of kilocycles, and the rapidity of frequency change would be absurd.

One I-F Amplifier Tube

This matter is still open. The highest frequency will not be much above 20 mc. The author has suggested to some of his conferees the idea of taking the two or three highest frequency bands, splitting them up about evenly, and selecting the coils on the basis of using half the angular displacement in turning the condenser from minimum. The capacity at the physical midpoint is considerably less than half of the total, so the frequency would be about 1.3, although encompassed over only half the dial. Any other way of attempting to meet the problem requires more padding condensers, both at the local oscillator and carrier levels, or use in general of a smaller capacity condenser, say, 0.000125 mfd. instead of around 0.00035 mfd. Then, of course, the broadcast band would be split. The idea of using two separate gangs, while practical, produces a cumbersome result and unlikely to meet with favor.

There need be no difficulty about the tuning operation, as a dual ratio of vernier mechanism could be used, say, 6-to-1 and 40-to-1.

On these points suggestions are indeed welcome.

There is only one intermediate-amplifier tube. The gain can be pressed to around 250 or 300, which is ample, and while two-stage systems have been tamed all right, it must be admitted that they are really not necessary and may become noisy. Also the gain readily becomes so great that the 55 triode becomes saturated, and delayed automatic volume control of a severe nature has to be introduced.

Separate A-V-C and Detection

The strict detection and a-v-c purposes of the diode are segregated. From the plate

of the i-f amplifier some of the voltage is led through the 0.0001 mfd. condenser to a 20-millihenry choke. Between this choke and cathode is the a-v-c load resistor. The value of condenser across it has no effect on tone, therefore may be increased above the 0.0001 mfd. value if greater a-v-c voltage is desired. The rectification efficiency increases as this capacity is increased, up to a reasonable value of capacity, say, 0.01 mfd.

The other diode, for strict second detection, or demodulation, also has a load resistor of 0.5 meg., across which is a condenser of only 20 mmfd. capacity (0.00002 mfd.), which, if much larger, would seriously attenuate the high frequencies of the audio component.

A stopping condenser is used between this diode and the grid of the triode of the 55, the 2-meg. potentiometer being the grid leak, augmented by a limiting resistor. Just what the value of this resistor should be is a matter of individual choice, but if it is satisfactory to limit the control to nine-tenths of the total, then it is well to include 0.2 meg., for then low-volume settings of the control never can interpose such low resistance between grid and return that the low-note suppression becomes serious. A minimum load of 0.2 meg. is ample.

Overload Safeguard

The 55 requires cautious treatment in other directions. The negative bias should be selected somewhat on the basis of conditions of reception at one's location. Use the strongest local as test. First disconnect antenna and ground (if ground is used), then, when the circuit is otherwise complete, remove the 2,000-ohm biasing resistor of the 55 and insert instead a 1.5-volt fresh dry cell, positive to cathode, negative to B minus. Read the plate current. This will be very small, but a 0-1 milliammeter will give satisfactory reading. Note this reading carefully. Then when cell is removed, biasing resistor restored, tune in the strongest local, and if the plate current reads higher than when the cell was in circuit, increase the resistance beyond 2,000 ohms, no matter how much more, until the plate current reads no more than when the cell was used, and if there is any difference, it should be in favor of less current reading. Then the triode is practically safeguarded against overload.

The parallel feed to the audio transformer is due to the desire to uphold the low-note response. This is particularly important where pentode output tubes are used. Since no direct current flows through the primary, the inductance of the primary is held up, and high primary inductance favors tone quality.

Power Tube Bias Test

In the filter of the grid circuit of the power tubes other values than 0.05 mfd. and 0.2 may have to be used, depending on the hum condition this is intended partly to eliminate. No grid current should flow in this circuit, either, and the same test may be made as before, using a 3.0-volt battery, positive to cathode, negative to ground. The bias from the 110-ohm resistor would not be used then. The total plate current in the 2A5 circuits may be quickly read with the battery bias as recommended, then the switch turned off and a 22.5-volt battery inserted for bias. The loudest local is tuned in, to check whether the plate current is greater than by the battery test. This check need not be made in a hurry, because there is no extremely low bias on the tubes, but the current should be certainly less during actual operation, otherwise the tubes are going to be put to quite a strain in ordinary use, and besides there might be plenty of distortion. In these tests the a-v-c should be working, of course.

It may turn out that the tests are a disappointment, in a sense, because no matter what the signal put in, from station or signal gen-

(Continued on next page)

Germany Starts Something

Television Phones Ordered After Demonstration at Berlin Exhibition Makes Hit

By Neal Fitzalan

RADIO fairs being held in the principal countries disclose that television is advancing, and as the stimulus of the show prompts the television exploiters to hit their stride, announcements are made of intentions to begin transmissions and offer receivers.

Germany has taken the lead, with an official announcement by the Post Office that an experimental setup of television-telephone service would be instituted. Berlin was the principal center of recent trials of the apparatus. The idea is to have the facilities for seeing the person whom you are talking to, and who is talking to you, while he sees you, also. And besides any plain objects could be exhibited.

The cost of apparatus is said to be very high, so that the Government is proceeding with caution, but it is plain that the Reich intends to do all possible to have Germany the first to put television to practical use, if not the first to commercialize it on a grand scale.

Compromise on Systems

The system on which the present plans are based is not without its limitations. The scanning disc in the transmitter circuit has the usual holes disposed spirally, with lenses to aid a bit, and the pickup is from movie film.

A method has been devised for taking pictures in one instant and having them developed and fixed in less than a minute and a half, and dry enough to be run through the sprockets for television transmission purposes. The pictures sent out occur twenty per second. The radio micro wave used in most of the experiments is modulated with the television scanning frequencies, while at the receiving end is a set equipped with a cathode-ray oscillograph tube. Thus the scanning at the receiver is electrical, while that at the transmitter is mechanical, a combination of the two systems which the world is now debating, and therefore something of a compromise.

The size of the picture as exhibited at the receiving end is not stated, but all experience so far shows that electrically-scanned pictures, using the oscillograph tube, while good, can not be large, as the illumination is not strong enough.

Mechanical systems also have been deficient in illumination, and there is hardly a system in the world that is familiar to followers of the art because demonstrations have been given, that does provide all the illumination required for a picture the size of a home-movie projection, say, 4 x 5 feet, although a recent demonstration in the United States, of a mechanical system, using only 60 lines, indicated that when the number of lines is doubled the goal will be reached.

Fair Crowds Get Treat

At the recent radio exposition in Berlin the crowds were given a real treat when a car equipped with a camera took shots of street scenes and close-ups, with subjects up to 20 yards off, quickly developed the exposures in the movie tank, and radioed the pictures to the fair, where a cathode-ray type scanner, hooked up to a receiver, permitted the crowds to see what had taken place only two or three minutes before.

This method also is a compromise, as it does not accomplish the complete goal being sought, that of direct pickup, and instantaneous scanning of the image for transmission, rather than reduction to film and then scanning the film. However, the simultaneous aspect is not needed for present public parade to a television bandwagon. The pictures carried 180 lines, and there were 25 pictures per second, an improvement over the 20-picture plan the Post Office intends to try. The extra five pictures aid the illusion of motion considerably, and the 180 lines used do not fall far short of the number required by some system that does afford sufficient light.

It is not to be expected that with present cathode-ray facilities and limitations that there will be enough light save for a small picture, 4 x 5 inches or so, if dependence is put on the illumination cast upon the fluorescent screen of such a tube. In fact, even the fluorescence deprives the picture of white light.

U. S. and Britain Rash

Germany has been eager to press forward with television, and has some extremely able scientists working in this field. Great ingenuity has been shown in the construction of different types of

mechanical scanners, using lens systems, some of them including orientated lenses and tiled planes for reflecting at angles, while workers like Baron Manfred Von Ardenne have not only shown good though small pictures, using the cathode-ray tube, but have solved problems of phase shifts and other forms of wave distortion peculiar to the tubes. In Germany they have never gone off half cocked on television.

Hardly the same can be said about the United States or England. British broadcasting stations have something or other in practically all the studios marked "Television," and when a foreign visitor asks, "What's that?" the announcer or director will explain that the matter is in abeyance, but that Britain is standing ready, as ever, for whatever may arise.

Certainly Britain has contributed vastly to radio. Aside from not having taken to it quite as fully and vastly as the United States, it has made technical contributions of no less magnitude, to say the least.

We Do Our Part

But there have been some bad starts on television demonstrations and stock-selling, some concerning one of the most poorly-illuminated systems ever given serious consideration, and representing experimental endeavor of a very meagre order. Now somebody is at it again in Britain, saying "Television is here," and advertising a scanner that can be attached to "an ordinary receiver" for bringing in pictures "that will give you a thrill you will never forget." Who is sending out the pictures, and when, are not stated in the advertisement, but with practically nothing of any account on the air even in the United States, we have had the same stock-selling experiences, and ballyhoo over haywire television outfits.

Radio exhibitions in the United States often, in larger cities, have television demonstrations. In fact, here, as elsewhere on earth, if anything is mentioned about a television demonstration, crowds flock to the show, when otherwise it might be much more difficult to get a sizeable attendance. These demonstrations, even those conducted by one of the largest electrical concerns in the world, have never been very convincing, al-

(Continued on next page)

Semi-Fixed Bias on Power Tubes

(Continued from preceding page)

erator, the plate current readings discussed will not differ much. That would be due to the effectiveness of the a-v-c and the constructor would have to decide whether he wants to increase the sensitivity and decrease the a-v-c a bit, as he could do by reducing the capacity across the a-v-c load resistor.

For biasing the power tubes a battery would be most satisfactory from an engineering viewpoint, but would be ruled out by constructors. The next choice would be a C-supply rectifier, requiring another tube and some chokes and condensers. The third best method is a close approach to the fixed-

bias conditions of the two methods previously stated, and that is bias derived from the B supply, where a considerable bleeder flows through the biasing resistor. This is semi-fixed bias. If a field of high enough resistance, proper wattage, and suitably tapped, could be put across the rectifier line that would be satisfactory. This increases cost.

A separate reducing resistor, shown as 6,000 ohms, is in the diagram. It may be that the speaker field is of sufficient wattage to carry the plate current for tubes ahead of the output, whereupon the field could be put closer to the rectifier, that is, transposed with the limiting resistor. At all hazards,

a biasing resistor of around 110 ohms or more would be used, for the current through this part of the network is all the B current of the receiver. We can figure on almost 100 milliamperes for the receiver, while the extra drain will depend in part on the bleeder resistance selection and may be 35 milliamperes, whereupon we would have to use an 83 rectifier. The 80 should not be pressed so far. However, no connections need be changed to install the 83, except that if some gurgling sound is heard that is really like oscillation, two r-f chokes would be used, inductance not critical, but 1 or 2 mlh suggested, one in each leg from the rectifier plates.

(Continued from preceding page)

though a corporation of such standing naturally took pains to state that the efforts were entirely experimental. Better pictures were shown, though small ones, by little concerns, while department stores that sought to draw crowds by television demonstrations, did draw crowds, but had practically nothing to show them. Even at radio shows, if the picture was pretty good, though small, it was no certainty that it could be reproduced when expected. Like as not there would be "No Television To-night" signs hung out.

More Sense Here Now

The television demonstrations in the United States have passed into more responsible hands. There is an exhibit at the Century of Progress Exposition in Chicago. There are occasional private showings of the work of RCA-Victor elsewhere. Philo T. Farnsworth, an "independent," is letting the public see what tricks he has in his bag, and William Hoyt Peck goes right on showing the most brightly-illuminated pictures in the television field that the world has yet seen, with a promise of greater illumination within a few months.

Peck uses a mechanical system of his own. Being one of the country's leading optical experts, he is "all eye" when it comes to lenses and illumination, and he scans a movie film with a small wheel about the circular edge of which are disposed tilted reflecting lenses, the tilt differences accounting for the scanning. His promise of a 120-line picture, using his special system of vertical extension of the slot to afford practically 240-line effect because of the increased illumination from focused light, has prompted eager expectations from industrialists interested in television "when the right time comes."

Is a Headlight Bright?

Peck uses the bright light from automobile headlights to provide the illumination, and has a special Kerr cell, about half the size of your little finger, to replace the bulky and insensitive photo-cells with which similar effort has been characterized.

On the economic side, some are urging that at present television seems out of the question, as it would cost \$80,000,000 to set up suitable transmitting equipment, especially as each local area would have to be served separately, due to the advisability of using a very high carrier frequency of short penetration. The high carrier frequency is regarded the world over as essential to proper television, for those who state that excellent pictures can be sent out on the broadcast band, do not accompany their statements by demonstrations.

Those who demonstrate usually have wires to conduct the scanned frequencies, thus dispensing with a radio-frequency carrier, knowing that what can be sent by wire can be better sent by radio, but lacking the showmanship to insist on demonstrating the thing that is wanted, instead of demonstrating something just a little different, with a statement nobody disputes, but which carries with it an implication of apology and a disappointment nevertheless. All demonstrations should use the r-f carrier.

Why High Carrier?

The Germans are working their television on micro waves and in the United States the same course is taken. Only one or two experimenters in England still adhere to the potentialities of the broadcast band, and similar frequencies, for carriers. The reason why a high carrier frequency is necessary is that for clear, bright, true pictures it is necessary to have a modulation band width of something like 250 kc. The broadcast band

in the United States has a total "band width" of only 1,060 kc, so one-quarter of the band would have to be taken up by modulation, thus putting about half the broadcasting stations off the air!

Dr. Vladimir Zworykin, working for RCA-Victor, has accomplished a great deal in overcoming difficulties attendant on use of the cathode-ray tube, and has a combined transmitting and receiving system. The pickup is the iconoscope and the receiver is the kinoscope. He uses a photo-cell area in the pickup that has a slow enough effect to retain the image, much as the retina of the eye does, only over a somewhat longer period, and this endows his system with "memory." At both ends the cathode ray is used, but at the pickup it is for purposes of scanning the ground-glass of an optical image collected by a camera, for delivery to the photo-sensitive surface, and at the receiving end it is for collecting the distribution of elements that are broken up at the transmitter, for viewing on the fluorescent screen. Thus he has a combined system, as have Peck and Farnsworth.

Light "Amplified"?

Peck has his own mechanical pickup method, worked with a movie film, and has brought to these endeavors his years of experience with color films in the movie industry. However, in television he is letting color severely alone for a while. Farnsworth has taken great strides in attempts to amplify light, a feat not hitherto known to the science, at least not without distortion. He picks up the scene with a camera, casting the optical image upon the stream of electrons of the pickup tube, and in front of an opening he shifts the electron image both up and down for the scanning process. By the electrical means the speed required is easily and silently obtained.

The photo-electric device he uses in this part of his work is caesium-treated silver, the amount of light and shade determining the degree of electron emission. This is a form of rectification of light. Thus is the optical image converted to electrical values.

Two silver cathodes in juxtaposition, worked in conjunction with the pickup tube, constitute the "multiplier," and the effect is that of increasing the number of electrons. Since these electrons represent the equivalents of light values, converted from their original form to electrical quantities, and since the amplitudes have been increased for subsequent purposes of reassembly of the optical picture, the system may be roughly described as one attempting the amplification of light. It is generally believed that for the cathode-ray oscillograph system of scanning to work satisfactorily for a large enough picture the equivalent of light-amplification has to be accomplished.

Sunlight Helps

Farnsworth at first demonstrated at Philadelphia the simultaneous antics of some tennis players—not movie film—but as more demonstrations were given day after day, he moved the "studio" from a room in Franklin Institute to the roof of that building, and got the benefit of sunlight. Thus actual outdoor set-ups were picked up, including some boxing of no championship calibre. The observers of the television screen in the auditorium downstairs were treated to "simultaneous" television, that is, saw the event on the screen the same time it was taking place upstairs. However, instead of using a radio-frequency carrier, Farnsworth sent the impulses over a cable.

The sunlight helped the picture a lot, which is only another way of saying that when you want television you want plenty of light. While some observers said that the pictures were very good, "equal to home movies, except that they were much smaller," this doesn't mean anything, for

Treble, Bass— and a Bit of Tremolo!

In a suit filed against the American Society of Composers. Authors and Publishers last week the claim was made that the ASCAP, as the society is known, has been thriving on a monopoly and that all the license-fee agreements now in full force among authors, composers, publishers and broadcasting stations should be declared null and void; also that hereafter the so-called airtight contracts shall not be permitted to continue and that every one interested in the deal from any viewpoint shall be declared restrained further from enforcing the present contracts or renewing them.

The American Society of Composers, Authors and Publishers declares that the Society is not now engaged in enforcing any contracts that are not founded on the very spirit as well as letter of the International Copyright Law and that all matters now under discussion have been passed upon by our courts, and that the Society is ready to have the whole situation cleared up now and for all time, so far as the copyright situation is concerned.

The Society, by the way, has a contract with the broadcasters covering the period ending July 31st, 1935. It is declared by the broadcasters that the income from radio alone will net the Society somewhere around \$1,500,000 yearly, if permitted to continue. The Society shrugs its shoulders as much as to say, "Well—and what about it?"

The Society declares that without its enforceable contracts with the broadcasters the music business is so shot to pieces that it would practically pass out of the picture.

And now it's up to Uncle Sam!

New Studio and Station Equipment to be Shown

An entirely new line of studio and station equipment will be displayed by the Western Electric Company in connection with the convention of the National Association of Broadcasters in Cincinnati September 16th to 19th. The display will include equipment covering virtually every requirement of speech input for broadcasting.

The features of the studio equipment are compact cabinet assembly, complete a-c operation eliminating all batteries, turret control and high quality amplifiers. The exterior of the apparatus is of modernistic design, composed of gray metallic finish with satin chrome trim.

The apparatus will be on demonstration in a suite at the Netherlands Plaza Hotel. One room will contain a microphone and a reproducing set for high quality records. These will be amplified through the new equipment located in the exhibit room where the records and voices of visitors will be reproduced by a loudspeaker.

if a picture is small enough even the illumination from a match is plenty. Television can not be equal to home movies until television produces practically the same detail, definition, steadiness and illumination for the same size picture, and the real demonstrations of the future should have simultaneous showing of duplicates of the same film, side by side, on the same screen, one by home movies of the \$100 projector variety, and the other by television. This may well be the climax of any demonstration that is to win a mark for itself, and should be preceded by a demonstration of simultaneous television, using a radio-frequency carrier, with outdoor scenes and events picked up, showings to include close-ups of persons with whose appearance most of the spectators are familiar.

Tuned Circuits Are Out Yet Oscillations Are Obtained, 150 to 15 Centimeters, in Electron Generator

By Bradley Warren

A METER is 39.37 inches. A centimeter is one one-hundredth of a meter, or 0.3937 inches. A wavelength of 150 centimeters is, therefore, 150 x 0.3937 inch, or 59.055 inches, or 4.92 feet. From this outside dimension to lower values oscillations are generated in vacuum tubes that have cylindrically-shaped elements (grid and plate), down to a few centimeters. The method applied is to put a positive voltage on the grid, a zero or negative voltage on the plate, and then either run two wires from grid and plate, with a short-circuiting bar that, when moved along, measures the wavelength, or omit these wires and simply have a wavemeter measure the wavelength.

The first work published on the method of using the wires, called Lecher wires, in conjunction with the reversal of customary voltages on the tube, was by Barkhausen and Kurz, fourteen years ago. These two Germans made an important contribution to the science. Moreover, they developed a formula for determination of the wavelength at which the tube would most readily oscillate, depending on the voltages applied and the distance between elements.

Looks Very Simple

E. W. Gill and J. H. Morrell contributed an extension of this system whereby the external wires determined the frequency of oscillation, at least in some instances, which could be duplicated. Therefore, the two types of circuits, the one where the wires are used only for measurement, Barkhausen-Kurz, and the one where the wires determine the frequency, together with the tube geometry, Gill-Morrell, are named for their discoverers, and much attention is being paid to the circuits these days.

Could anything be simpler than the circuit illustrated herewith? It seems almost childish and any novice would be glad to experiment with it, without fear of running into much trouble, wouldn't he? And yet some of the leading radio scientists are working with circuits just like that diagram, constantly having trouble, yet constantly making contributions to the science by virtue of their findings.

The oscillations really arise from the back-and-forth movement of the electron stream in the space between the elements of the tube. As the frequency approaches that of the maximum speed of electrons in usual circuits trouble begins, and oscillation stops, so here we have circuits that start where the others leave off, the frequency determined by the tube elements or the voltages applied, because the voltages are the driving force and determine the speed of the electron "cars."

Plate Gets Some Electrons

Naturally, the operation is near or at saturation, that is, that point where practically all the electrons emitted by the Cathode (filament) are attracted to the other elements. Most go to the grid, for it is the grid that is positive, but some get to the plate, despite zero plate voltage. Because of this heightened operation, and especially the flow of considerable current in an element not originally intended to carry large current, the grid, tube life is

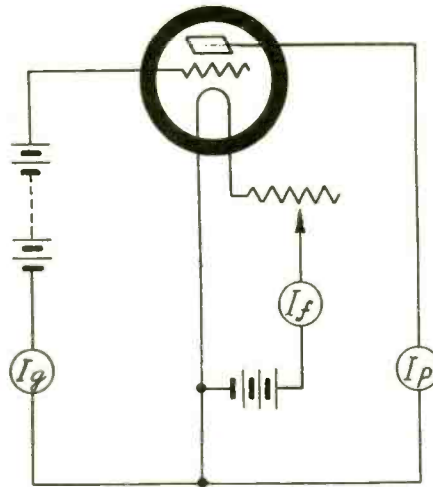

Diagram for generating electron oscillations without tuned circuits.

short in Barkhausen-Kurz and Gill-Morrell operation.

It has been pointed out by some, despite the contribution of Gill-Morrell, that the Lecher wires alone determine the frequency, constituting a load on the circuit. This is not accepted at all.

Recently some new work has been done on the electron-oscillator circuit by W. H. Moore, of the Canadian Marconi Company, Ltd., Montreal, Canada. He removed the Lecher wires and got nice oscillations just the same, and over a wide range of centimeter waves. He started at 150 centimeters and went down and down in wavelength, say to measurably below 15 centimeters, or a wavelength shorter than the rule under the date line on this page. He reported on his work in the August issue of "Proceedings" of the Institute of Radio Engineers.

Looks Like Instability

Others have removed the Lecher wires, too, and gotten results, but Mr. Moore has made new calculations of the oscillation frequency when no tuned circuit was connected to the Barkhausen-Kurz rig.

He got some unexpected results, too. Some tubes, with certain voltages applied, oscillated readily at one wavelength and also at another. In fact, sometimes the oscillations would themselves oscillate, that is, jump from one frequency to another, voltages remaining unchanged. This, of course, denotes a high order of instability, but not much has been definitely accomplished yet in the stabilization of such circuits, and the very fact that the voltages themselves greatly change the frequency of oscillation would connote to most experimenters that the systems are in that sense still unstable. There is an exception, noted below.

Some of Mr. Moore's experimental findings include:

Presence of radio-frequency chokes in the grid, plate and filament leads did not change the frequency of oscillation, therefore, these chokes were omitted.

Leads were moved about to ascertain whether the external connections were

providing a resonant circuit. This movement did not affect the wavelength, either.

Not More Than 200 Volts

Filament current was held in most instance to the rated value.

Increasing the positive voltage on the grid beyond 200 volts did not result in the production of further oscillations. Besides, at higher voltages there was danger of damage to the tubes due to excessive heating.

Putting a small negative bias on the plate reduced the amplitude of all oscillations, hence plate was tied to filament, that is, the potential on the plate was zero. (In a battery-operated filament-type tube this would mean plate tied to negative filament.)

After testing several tubes, he found that, with positive grid voltage of around 100 volts, the wavelength of oscillation was consistently around 80 centimeters.

Besides one additional region of oscillation, already mentioned, in some instances, with the same voltages applied to the same tube, two additional regions of oscillation were encountered, that is, total three.

Starts at 45 Volts

Wavelengths were measured by means of absorption type wavemeters, the indication being obtained from the deflection of a plate-current meter.

Experiments bear out the assumption that the general type of oscillation investigated does not begin until the tube has reached its saturation value. Only one exception was noted.

The first region of oscillations was in the neighborhood of 45 volts positive on the grid, strict Barkhausen-Kurz oscillations.

Second regions of oscillation took place in the filament-plate space.

Third regions were explained as due to Gill-Morrell oscillations, when the grid and plate electrodes formed the tuned circuit. This condition is explained as being one of frequency constancy, or nearly so, as the wavelength dropped just a little as the voltage was increased, instead of following the sharper curve of the Barkhausen-Kurz system.

SUBSCRIBE NOW!

YOU CAN GET TWO FULL YEARS—
104 ISSUES—ONE EACH WEEK—FOR \$10.00

RADIO WORLD, 145 West 45th St., New York City. Enclosed please find my remittance for subscription for RADIO WORLD, one copy each week for specified period.

\$10.00 for two years, 104 issues.

\$6 for one year, 52 issues.

\$3 for six months, 26 issues.

\$1.50 for three months, 13 issues.

\$1.00 extra per year for foreign postage.

This is a renewal of an existing mail subscription (Check off if true)

Your name

Address

City

Blueprint of Calibrated Station-Finder

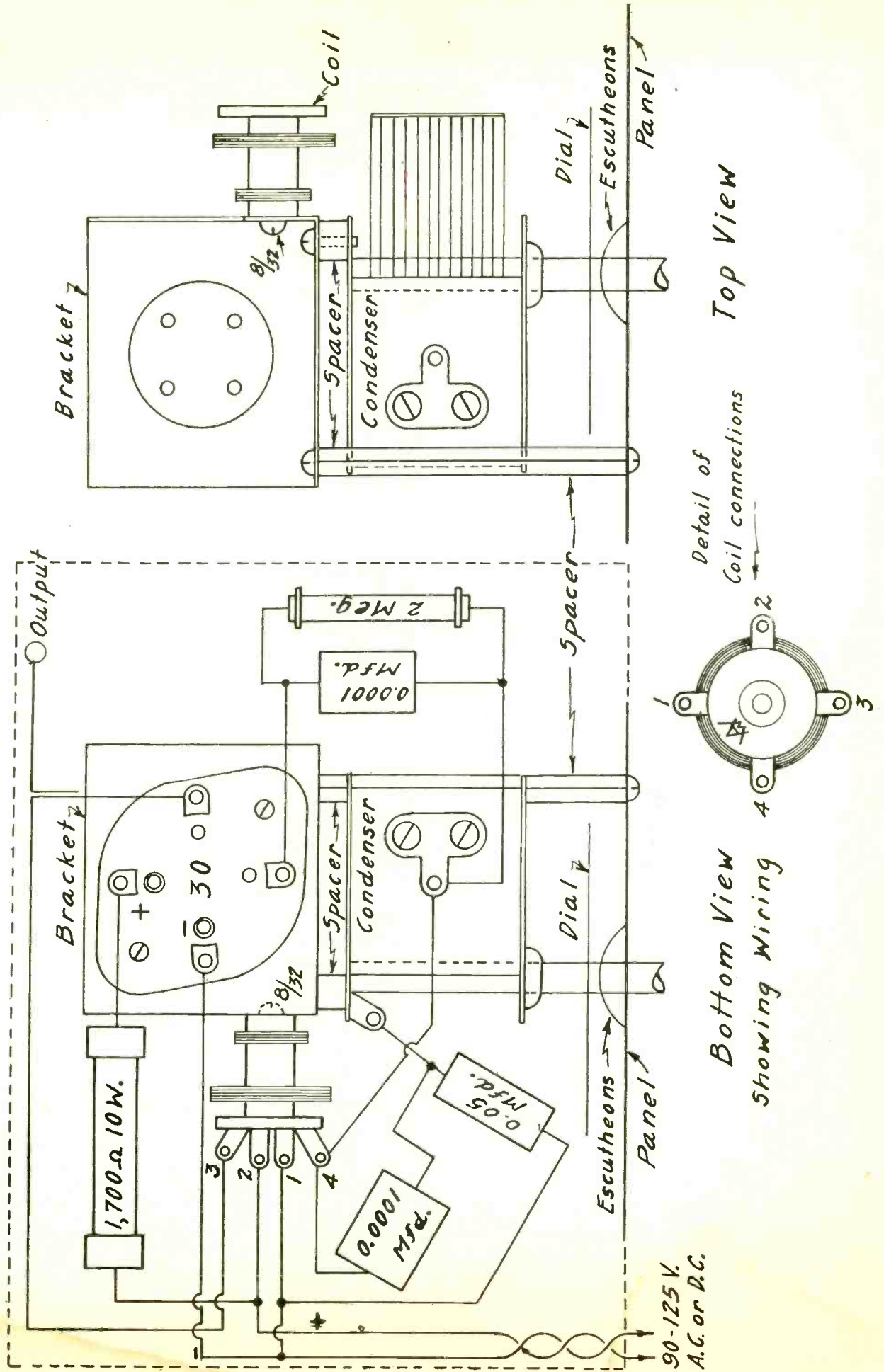

Station-Finder Operation

Unknown Frequencies, 108 kc to 40.6 mc., Measured

By Herman Bernard

THE Station-Finder, Model 335, consists of a signal generator covering fundamental frequencies of 108 to 200 kc, useful on a.c. (any commercial line frequency), d.c. or batteries. On a.c. the line hum is the modulation. On d.c. or battery use there is no modulation.

On the front panel are two escutcheons, a knob and output post. Each escutcheon has a double pointer, one on top, one on bottom. There are thus four scales indicated.

The topmost scale is the fundamental, 108 to 200 kc. The calibrated dial, which is behind the panel, should be set so that when the condenser plates are totally enmeshed, full capacity in circuit, the dial reads 108 on the top pointer. Then the setscrew is tightened, the setting checked again, as the tightening process may move the dial position a bit, and a test made at or near the high-frequency end, using a broadcasting station.

One Adjustment

As the scale for the upper tier has 1 kc separation, the frequencies are 200, 199, 198 kc, etc. Therefore the fifth harmonic of the generator may be used as a check for frequencies of 1,000, 995, 990 kc, etc., to 540 kc to beat with stations.

If the generator frequency reads too low, increase the capacity of the grid condenser that is across the grid leak. If the frequency reads too high, decrease the capacity of this same condenser. If any change is necessitated in this way, the low-frequency end will not be affected, as it has been set, as it should be, for 108 kc for plates enmeshed fully. Therefore, if any adjustment is necessary, it is just one adjustment.

The details of putting the parts together are shown fully in the diagrams and need no discussion, except perhaps a note of the fact that actually two spacers are used to hold the assembly of condenser and bracket to the front panel, which is metal. One of these spacers, not shown, is held to the condenser frame, lower right of the side view, the other end of this spacer being fastened to the front panel.

A knob turns the condenser shaft by the direct-drive method. This has to be an exceedingly small knob, so as to clear the escutcheons. Also, the escutcheon pointers are not exactly true, one being displaced one degree of arc from the other, but this fact has been taken into consideration in calibrating the scale.

Escutcheon Data

The fact does require, however, that the escutcheons be fastened to the panel in the correct way. The positions of pointers of an escutcheon, therefore, are not reversible. The test can be made for the upper escutcheon by fastening it so that 130 kc on the top row coincides with 260 kc on the row second from top. Turn the escutcheon upside down as a test. The lower row may be coincided by having 4.8 mc (lowest tier) coincide with 2,000 meters. If need be, to make these adjustments, either one of the mounting holes of each escutcheon may be drilled larger on the escutcheon itself, or one of the corresponding holes in the panel, and the escutcheon justified by shifting
(Continued on next page)

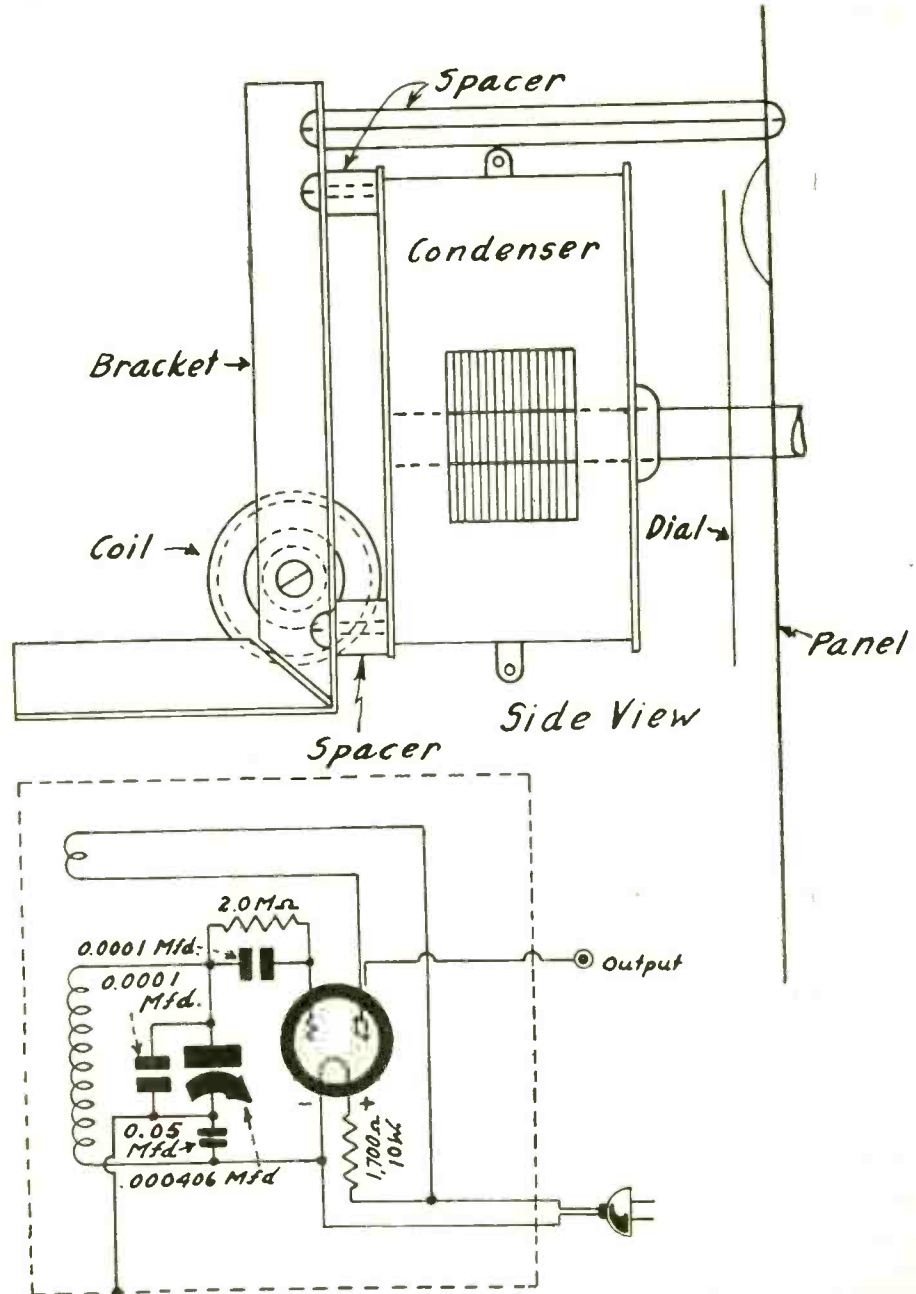

Side view and wiring circuit of the Station-finder. The wiring in pictorial form is shown on opposite page.

LIST OF PARTS

- | | | |
|--------------------|---|--|
| Coils | One r-f oscillation transformer, secondary inductance 3.7 microhenries. | One output pin jack with two insulators. |
| Condensers | One 406 mmfd. variable condenser. | One a-c cable and plug. |
| | One 0.05 mfd. fixed condenser. | One bracket for use as tube chassis and to hold condenser frame. |
| | Two 0.0001 mfd. fixed mica condensers. | One UX (four-prong) socket. |
| Resistors | One 1,700-ohm, wire-wound 10-watt resistor. | One metal front panel. |
| | One 2.0-meg. grid leak. | One metal box. |
| Other Parts | One frequency-wavelength calibrated dial. | Two holding spacers. |
| | Two escutcheons. | Six 6/32 machine screws. |
| | | One 8/32 machine screw. |
| | | Four small self-tapping screws for escutcheons. |
| | | One very small knob for 1/2-inch shaft of condenser. |
| | | One 30 tube. |

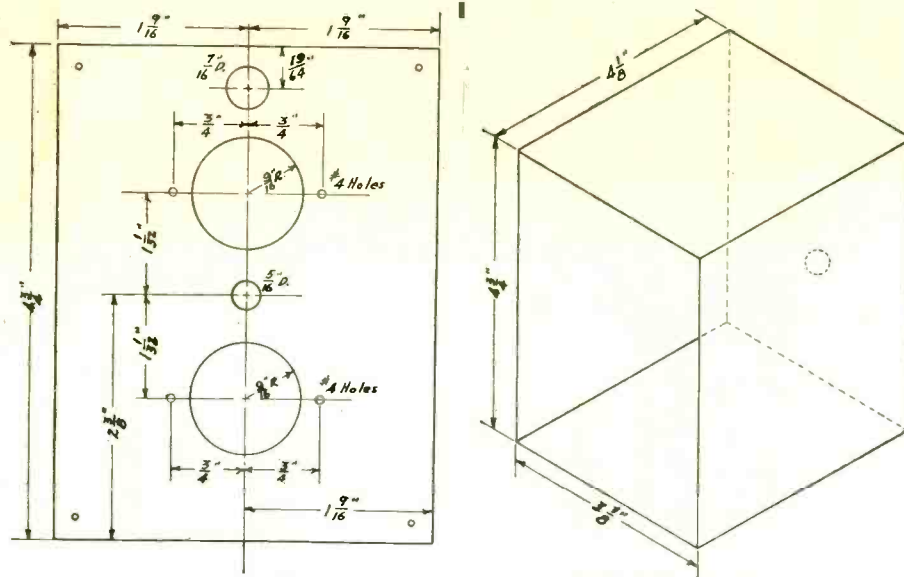

Front panel of the 335 Station-Finder. This instrument also may be used for lining up broadcast and intermediate frequencies. Shield cabinet dimensions are at right.

(Continued from preceding page)

that way and then being fastened securely.

The coil connections for oscillation are diagrammed in the pictorial blueprint. The initials on the coil form are followed as guide. On either side of the initials is a secondary terminal. No. 4 goes to stator of the tuning condenser and No. 1 to that side of line used as negative. To left of the pictorial diagram the negative and positive signs are found. The generator oscillates during the positive part of the cycle of the line voltage.

No. 2 goes to positive of the line and No. 3 to plate. The improvised condenser connecting plate to output consists of some insulated wire tightly wrapped around the lead from plate to coil terminal, without conductive connection. The coupling can be made whatever is desired, by increasing or decreasing the number of turns thus tightly wrapped. About 3 inches of wire wrapped around this way should prove ample. The start is made at least half an inch away from the plate prong of the socket.

How to Use the Device

The fundamental frequencies have been discussed so far in connection with adjustment of the generator to the scale. The frequencies now will be discussed in connection with actual use of the generator.

Intermediate Frequencies — Since the fundamentals are 108 to 200 kc (with additional bars for 201 and 202 kc for convenience), it is practical to line up intermediate channels of receivers at these frequencies, using the fundamental. The fundamental may be identified because as the generator is tuned over its entire band, only one response is heard in the measured circuit. Two responses cannot be heard on fundamentals because the frequency ratio of this instrument is a bit less than that required for possibility of even one second-harmonic response, that is, less than 2-to-1.

Besides fundamentals, harmonics may be used, for higher intermediate frequencies, and the principal intermediate frequencies appear twice on the second tier from top. This is because two responses will be heard, and some confusion could result, the user not being certain he has the intermediate channel set at the right frequency. Therefore, all doubts are dispelled if the response, say for 465 kc, is heard at one position marked 465 and at the other position marked 465. Then either position may be used. The i-f chan-

nel frequency must be 465, otherwise the two responses would not be heard at these positions. The same applies to 480, 470, 460, 455 and 450 kc, also marked on the second scale from top.

Determining Harmonic Order

Although a second harmonic is used for 260 kc, only one response is heard, because 130 is the fundamental, the second harmonic being 260 kc, whereas for a third harmonic the fundamental would have to be 86.66 kc, which is off scale.

For those frequencies imprinted on the second row from top, the harmonic order being used may be determined by observing the frequency indicated on the top scale for any position selected, and dividing that frequency into the one on the second scale from top.

Any intermediate frequencies not accounted for by the top or second from top scales may be determined by dividing the desired intermediate frequency by 2 or 3, and using the result as found on the fundamental (topmost scale). Check against harmonic confusion may be instituted by noting how close the setting is at on scale second from top to some i.f. imprinted there, and confirming that about the same space between the second response point and the repetition of the inscribed lower-tier frequency prevails. This is true because the tuning curve is practically straight frequency line. Also, for the use of third and fourth harmonics, when any one fundamental is divided into a higher fundamental constituting adjoining response, the result will be 1.33.

On d-c line use, although no modulation is provided by the instrument, the line noise and commutator ripple usually are sufficient modulation. Use of 90 volts of B battery to run this instrument is wasteful.

Checking Harmonics

Broadcast Band—Since the lowest frequency generated is 108 kc and the highest 202 kc, the fifth harmonic is used for determinations from 5×108 to 5×202 , or 540 to 1,010 kc. For the rest of the broadcast band, and beyond, the tenth harmonic is used, 10×108 to 10×202 , or 1,080 to 2,020 kc. There would be a 70-kc blank by this method, from just above 1,010 to 1,080, but the eighth harmonic of 125 to 135 kc may be used instead.

A check on the correctness of the harmonic used in the broadcast band, or elsewhere, may be made, by using a generator setting for providing the response. then

turning the dial in either direction until the next response is heard. When the one fundamental frequency read is divided into the adjoining fundamental frequency read for fifth and fourth harmonics at the low end and fifth and sixth harmonics at the high end, the result will be 1.25 to 1.2.

For checking on harmonics used for 1,080 to 2,000, two adjacent responses, by dividing the smaller into the larger, will yield 1.11 to 1.2.

Short-Wave Bands—The lower tier of the bottom scale is calibrated from 2 mgc to 20 mgc. To 5 mgc this calibration is in steps of 0.2 mgc (200 kc). Beyond that the steps are in 1 mgc and principally useful for getting the frequency bearing of a receiver or station without exact determination. The megacycle steps are accurate, but, of course, the jumps above 5 mgc are too great for much practical use.

This lowest scale is used as follows: Set the generator at 200 kc fundamental, indicated by S on this tier, representing "Start." The receiver is tuned to provide a response when the generator index points to S. Do not count this response, first or starting, but do include the last one in the count. Slowly turn the dial to lower frequencies, and carefully count until eight responses are heard. Read the unknown frequency on the lower scale, in megacycles.

Which Harmonic?

To know what harmonic you are working on, convert the megacycles to kilocycles, by multiplying by 1,000. Read the frequency of the fundamental on the upper scale of the top escutcheon. Divide this low-frequency reading into the high-frequency one. Example: Lower reads 4.8. This number represents megacycles. Multiply by 1,000 to obtain kilocycles, e.g., 4,800. Top index reads 150. Divide 4,800 by 150, equals 32. You are working on the 32d harmonic.

If the frequency of a station being received is not a multiple of 200 kc the harmonic counter of the lowest scale does not apply directly, but the receiver may be detuned slightly to bring in a response from the generator, the frequency in mgc of this receiver setting determined, also the harmonic order, and the station tuned in again and the generator slightly retuned, to beat with the station being received, the new fundamental read being multiplied by the same harmonic order. This applies only for small changes in frequency of the generator. A better method will be detailed.

Table Given

Many stations operate on frequencies that are multiples of 0.2 mgc, therefore, the lowest harmonic-counter scale is valuable as it stands, despite a reduction in value as frequencies to be determined become much higher than 5 mgc. However, for any frequencies to be measured, and as a method of check even on the harmonic-counter tier, any two frequencies of the fundamental (topmost scale) may be multiplied by each other and divided by their difference. Example: The two frequencies read on the generator are 200 and 196 kc (topmost tier). Their product is 39,200. Their difference is 4. Then $39,200/4$ is the unknown, 9,800 kc, or 9.8 mgc.

Usually some approximation is known, as when using the generator with a frequency-calibrated set wherein the frequencies are not accurately maintained, or even with other sets, where different band-switch positions, or different coils plugged in, are known somewhat in respect to the frequencies obtainable. In the light of the foregoing the following table of the values of unknown frequencies, applied to two adjoining responses, when the generator is tuned and the receiver left at

some frequency, enables a rapid determination:

Responses on Generator Fundamental	Unknown Frequency Then is in Mc	Responses on Generator Fundamental	Unknown Frequency Then is in Mc
108 and 109...	11.77	125 and 126...	15.75
109 and 110...	11.99	126 and 127...	16.0
110 and 111...	12.21	127 and 128...	16.26
111 and 112...	12.43	128 and 129...	16.5
112 and 113...	12.66	129 and 130...	16.77
113 and 114...	12.88	130 and 131...	17.02
114 and 115...	13.11	131 and 132...	17.29
115 and 116...	13.34	132 and 133...	17.56
116 and 117...	13.57	133 and 134...	17.82
117 and 118...	13.80	134 and 135...	18.09
118 and 119...	14.04	135 and 136...	18.3
119 and 120...	14.28	136 and 137...	18.63
120 and 121...	14.52	137 and 138...	18.90
121 and 122...	14.76	138 and 139...	19.18
122 and 123...	15.00	139 and 140...	19.46
123 and 124...	15.25	140 and 141...	19.74
124 and 125...	15.5	141 and 142...	20.02

Extension of Method

For the unknowns, other response points are obtainable in the receiver as a result of tuning the generator, but in applying the above table should be ignored, and the consecutive responses due to even-bar positions of the topmost scale, as above set forth, should be followed. The results are obtained, as found in the table, simply by multiplying together the two frequencies read, and of course may be extended by going beyond 142 kc for determination of higher unknown frequencies. Thus, if the receiver responded sensitively to such a frequency, 201 and 202 kc fundamentals could be used for measuring 40.6 mcg (201 x 202 equals 40,600 kc, closely).

To obtain values of the unknown besides those encompassed above, using either even bars at any positions that yield responses, or estimating between 1/3, 1/2 kc, the whole spectrum may be covered, for all short waves, and also for broadcast waves, by multiplying any two adjacent response frequencies read, and dividing by the difference, as already detailed.

If one prefers to select a point on the generator that yields a response that requires no estimating, he may turn the dial of the generator until exactly on some bar there results a response in the receiver, then, not counting this first response, keep tuning and counting responses until there is a response exactly at some other kc bar of the topmost scale. Include the last response in the count. Then the unknown is obtained from the same formula as before, except that the number of responses heard, including the last, is multiplied by the computed number. Thus: if the frequencies read exactly on bars are 120 and 160 kc and the number of responses (not including the first but including the last) was 10, then the unknown is the product of 120 and 160, or 19,200, divided by the difference, 40, result 480, multiplied by the number of enumerated responses (10) giving the unknown as 48,000 kc, or 48 mcg.

The Wavelength Scale

The second tier from bottom is calibrated in wavelengths of the fundamental, 1,500 to 2,700 meters, in steps of 10 meters. Therefore, to ascertain any unknown wavelength in meters, again get two consecutive responses from the generator, leaving the receiver fixed, note the wavelengths, and the unknown wavelength in meters is equal to the difference between the two wavelengths read. Example: If one reading on the generator is 2,600 meters and the other is 2,550 meters, then the unknown wavelength is 2,600 minus 2,550, or 50 meters.

The frequency in kilocycles can be obtained by dividing wavelength in meters into 300,000. For answers in megacycles divide into 300.

To convert the wavelength in meters to frequency in kilocycles by use of the gen-

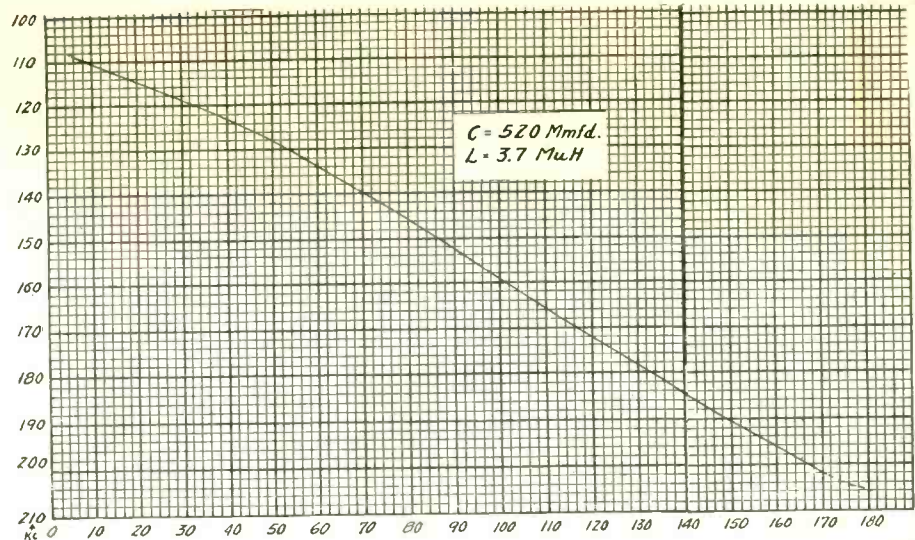

The tuning curve of the 335, using a 406 mmfd. tuning condenser with 1,000 mmfd. (0.0001 mfd.) in parallel, across a secondary of 3.7 millihenries. That accounts for the fair approximation of a straight-frequency-line curve. The degrees of a circle are read on the horizontal, while the frequencies are read on the vertical.

erator, find some wavelength that is a multiple of the one in issue, read on second from bottom scale, and then multiply the frequency read on the topmost scale by the multiple. Example: 50 meters equals what frequency? Use 2,500 meters, equals 50 x 50. Read frequency of 2,500 meters on topmost scale, 120 kc. Multiply 120 kc by 50, equals 6,000 kc.

Connections to Set—For intermediate frequency measurements, for lining up such channels, remove the antenna from the receiver, and if practical, stop the local oscillator in the set from generating by shorting the condenser that tunes the receiver oscillator. Connect the output of the measuring generator to the plate post of the first detector tube, leaving that tube in its socket. Then set the generator for the desired frequency and tune the i-f channel for maximum sound response or maximum deflection of an output meter or maximum illumination of an output-indicating lamp. Check for certainty of frequency by the harmonic reference system on the dial, or, if not on the dial, by dividing one frequency into the other, where adjacent generator responses are used, and noting that the result is 1.33.

For broadcast frequencies, if antenna is left connected to the receiver, sufficient response will be obtained including beats with stations, if a short wire length,

enough to reach the floor, is attached to the generator output post, and then there will be no frequency disturbance due to coupling.

Connections and Tuning

Connections for Short Waves — The coupling may have to be increased between generator and receiver for short-wave measurements, and particularly for quite high frequencies must be so increased. This is done by using a longer stretch of wire, enough to reach the aerial leadin where it enters the set. Enough turns of insulated wire from the generator's output post are wrapped around the leadin, outside the set, to produce a response of satisfactory volume. As frequencies become higher and higher responses become weaker and weaker. This is due to the drop-off in the sensitivity of the receiver more than to diminished intensity of harmonics, for once a high order of harmonics is used, the ear scarcely notices the diminution of the intensity due to the harmonic order increasing.

No ground need be used with the instrument and it was calibrated without ground. In tuning it is well to keep the hand off the panel, and simply hold the dial knob with two fingers, otherwise there might be a little detuning, especially when very high frequencies are being measured.

Directions for Using Switch-Type Generator

SOME of the principles applied to the 335 Station-Finder are used in the 333 Signal Generator, which is more particularly suitable for servicing receivers, although a station-finding feature applies. It was presumed that many would appreciate a small, inexpensive device that would enable them to line up sets, also find out the frequencies of stations, short waves as well as broadcasts, even though foregoing some of the advantages that a more expensive service instrument would have. Especially for station-finding, many would want an instrument that gave good service, though one might not even know how to or even want to line up an intermediate channel, hence would not deem it advisable to lay out the extra money a service instrument would necessitate. Besides, station-finding can be

done readily by use of harmonics without switching, whereas many service men want to work with fundamentals as much as possible, within cost limits. Hence the 335 was designed for low cost consistent with necessary service.

For station-finding an attenuator (output control) is not important, but for a service instrument, like the model 333, it is advantageous. Therefore one is included. Moreover, for servicing, if an instrument is universal, it should have modulation strongly present on d-c or battery use. Therefore a neon lamp is used as audio oscillator. Moreover, coupling methods become important in a service instrument, and therefore electron coupling is used not only between the r-f generator and output but also between the

(Continued on page 14)

Full-Sized Blueprint of t

Harmonic Counter Applicable to High Frequenc

83 kc to Above 20 m

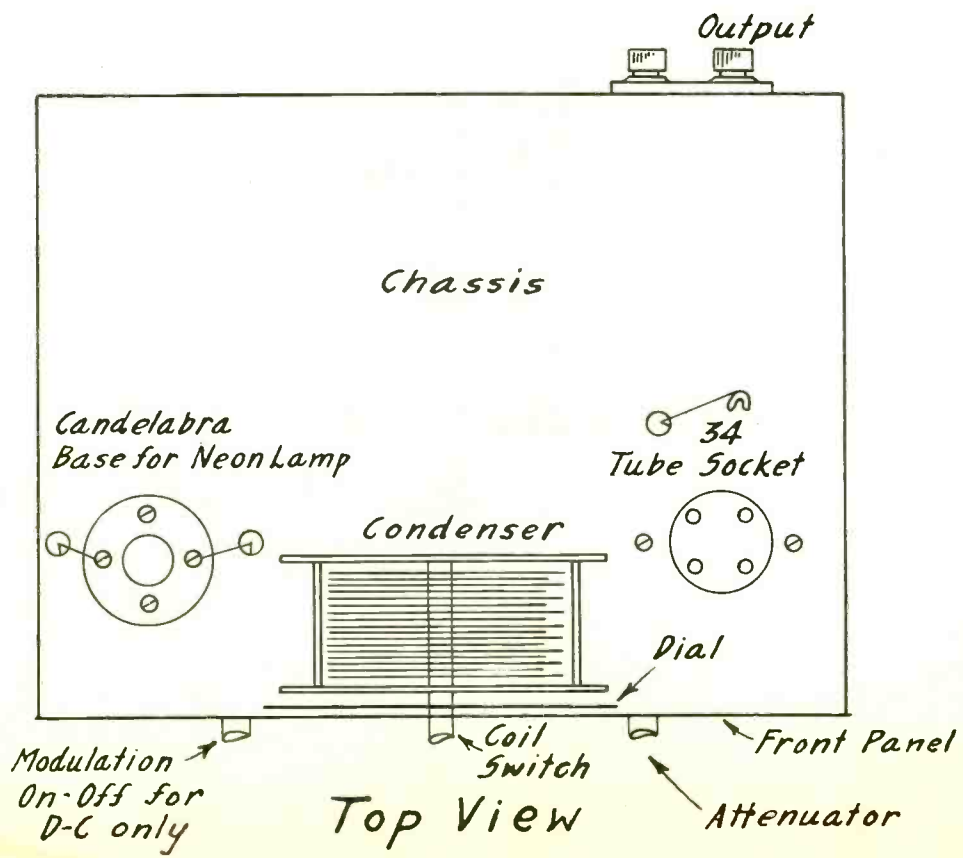
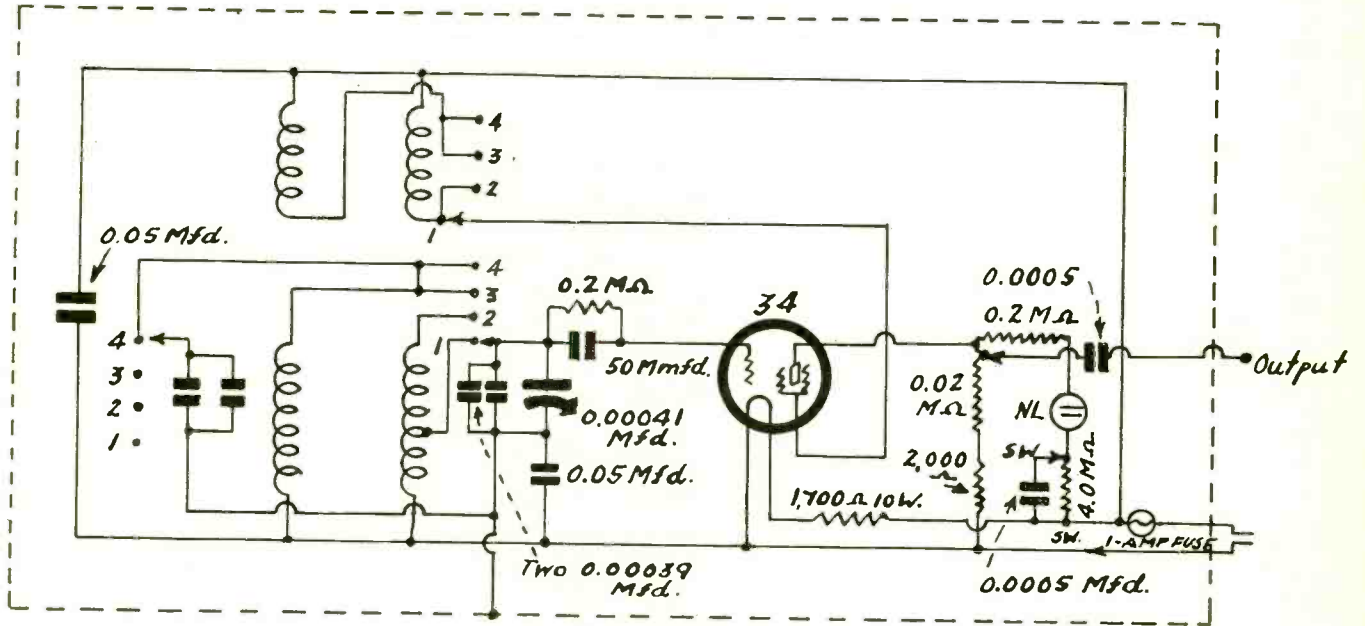

The 333 Signal Generator

ies and Low Wavelengths—General Coverage,
ngc—Switching Used

OUTPUT

110V. A-C

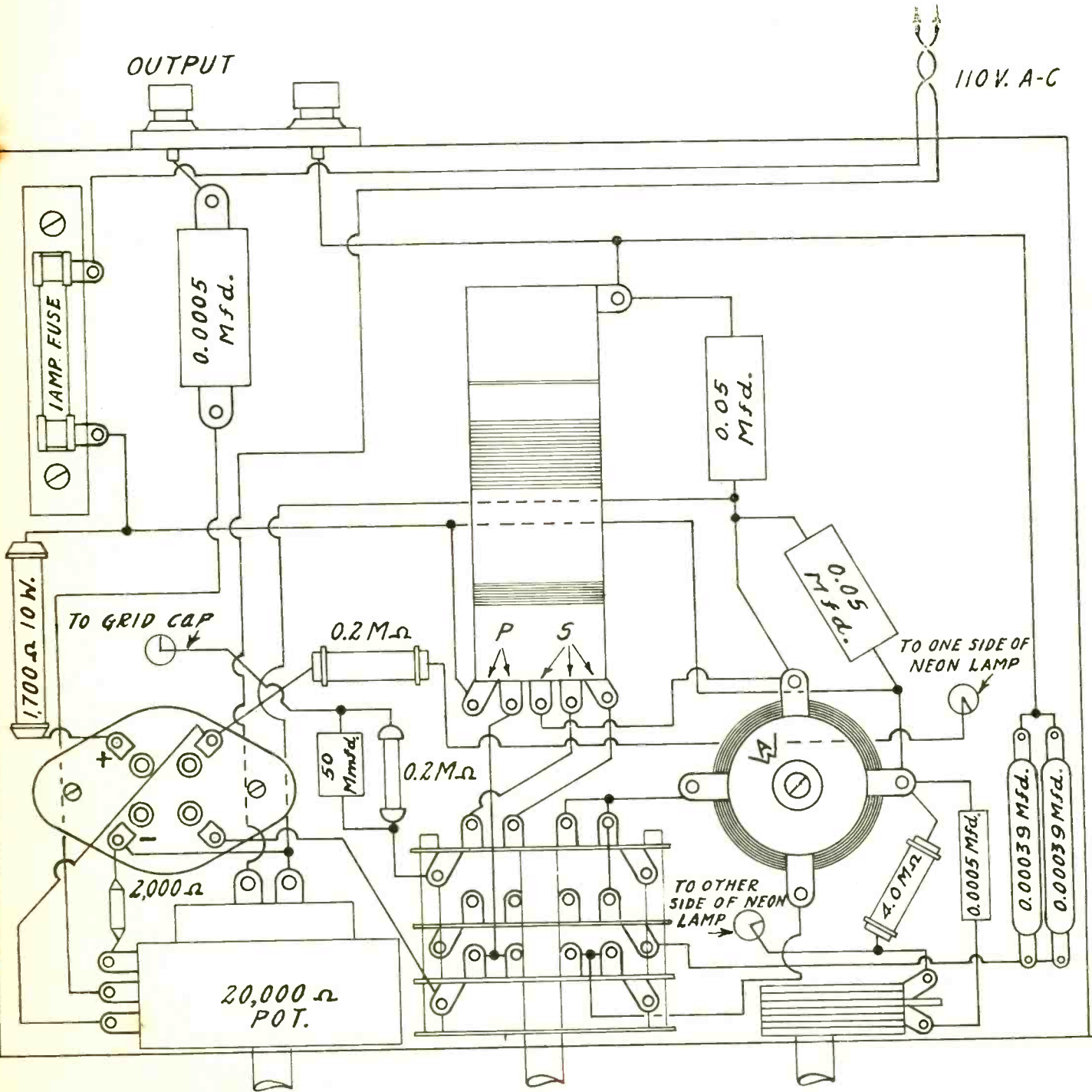

Bottom View

(Continued from page 11)

a-f and r-f generators. Then, too, there are four bands using fundamental, of 83 to 99.9 kc, 140 to 500 kc, 540 to 1,600 kc and 1,620 to 4,500 kc, with a calibration also for the low-frequency band in meters, 3,010 to 3,600 meters. Therefore frequencies may be determined directly from fundamentals within range, harmonics may be used by the errorless method of computation set forth in the discussion of the 335 in previous columns, and unknown values in wavelengths are determinable, to as low waves as present servicing requires to be measured.

The 333 circuit was written up in last week's issue quite fully, and this week the pictorial diagram is printed for wiring. There is a third model, also a signal generator for servicing, using 34 and neon tubes, having attenuation, no switching, and is otherwise like the 335, scale and all. That is the 334, blueprint of which will appear soon.

Much on Fundamentals

As intimated, the Model 333 hasn't much to do with harmonics. Since it is primarily a service instrument, the intermediate frequencies most commonly encountered, from 140 to 500 kc, are read right off the scale when the band-selector switch is at 140-500. The next most important consideration is the broadcast band, 540 to 1,600 kc, taken care of in full on fundamentals also, so the principal coverage already is attained. Of course short-wave alignment will become more and more important in time, but there is a scale for the intermediate short-wave band, permitting use of fundamentals from 1,620 to 4,500 kc. When you get to 4,500 kc, 4.5 mc., you are well into where you want to go. As far as you need to go these days will be taken care of by the fourth harmonic of this band. However, there need be no confusion due to the harmonics.

The low-frequency fundamental is provided, 83 to 99.9 kc, so that old sets, such as the Victoreen and Magnaformer, can be serviced at the intermediate level, 90 and 92 kc for that pair, and also so that harmonics may be used of an easily-read band.

There is provided enormous spreadout, with part of the curve truly straight-frequency line, the high-frequency quarter being greatly spread out, however. To this scale, therefore, it is easy to apply the formula of product of two adjacent response frequencies divided by the difference between those frequencies, equalling the unknown, for the original numbers are so low. Besides, for determination of unknown values in wavelengths, that is easy, too, because of the wide separation, or small wavelength coverage, only a total of 590 meters over 180 degrees.

Directions Given

Directions for use follow:

(1) Connect the cable plug to the line. If a.c. is used (and it may be any commercial frequency), the signal generator will work no matter in which direction the plug is connected. On d-c line use, however, there will be oscillation only when the plug is inserted one way, hence if oscillation fails, remove plug from outlet and restore in outlet the only other way.

(2) For intermediate frequency tests, remove the antenna from the receiver, also stop the set's local oscillator by shorting the tuning condenser serving it. Connect a wire from output post of generator to plate post of first detector, leaving first detector tube in socket. Turn on the switch attached to attenuator. If a set manufacturer gave any directions for peaking i.f. in his receiver, and those directions differ from foregoing, follow the manufacturer's advice. There are numerous methods and some particular

LIST OF PARTS

(For Switch-Type Generator, Model 333)

Coils

One r-f oscillation transformer, secondary inductance 3.3 microhenries.
One r-f transformer, secondary inductance 230 microhenries, tapped at 25.5 microhenries.

Condensers

One 406 mmfd. tuning condenser.
One 0.01 mfd. mica fixed condenser.
One 0.0001 mfd. mica grid condenser.
One 0.05 mfd. fixed condenser (tubular).
Two 0.0005 mfd. fixed condensers.
Two 0.00039 mfd. precision mica fixed condensers.

Resistors

Two 0.2 meg. (200,000-ohm) pigtail resistors.
One 2,000-ohm pigtail resistor.
One 4.0-meg. pigtail resistor.
One 1,700-ohm, 10-watt resistor.
One 20,000-ohm wire-wound potentiometer, shaft-insulated type; a-c switch attached.

Other Parts

One crinkle-finish metal box and chassis, punched.
Two escutcheons.
One calibrated dial.
One UX (four-prong) socket.
One candelabra socket for neon lamp.
One a-c cable and plug.
One 1-ampere fuse and holder.
One output twin post assembly (ground post included, need not be used).
Three bar handles for ¼-inch shafts.
One round knob for ¼-inch shaft.
One 0-100 scale plate for left-hand side of panel (*).
One frequency-band—index scale plate for lower center of panel.
One volume-direction index plate for right-hand side of panel.
One three-deck, four-position switch.
One screen-grid cap.
One 34 tube and one candelabra-base neon tube (¼ watt or ½ watt type sufficient, preferably of type without limiting resistor built in).

**This scale has no particular application to the numerals, unless on d-c battery use it is desired to include a potentiometer at left-hand panel front, with the neon lamp modulation switch attached, whereupon the 0.2 resistor from neon lamp to plate would be 0.1 meg. instead, and between one side of this 0.1 meg. and neon lamp would be put the potentiometer, 500,000 ohms or so. Thus on d-c and battery use the percentage modulation would be controllable. This feature (on d.c. or batteries only) is present in a commercial model.*

ones apply to specially-circuited receivers.

(3) For broadcast use, leave areal removed from set and run a short wire from output post of generator to antenna post of set, as short as practical. If zero-beating with broadcasting stations is to be practiced, this can be done sufficiently for late receivers (1932 up) with the short wire stretch serving as aerial for the set, otherwise use a longer wire, but not the full and usual antenna, unless the receiver is not a very sensitive one.

(4)—For short waves, the first or intermediate short-wave band, is treated the same way as the broadcast band. For frequencies higher than 4.5 mcg, get two responses on the 1,620-4,500 kc band, with selector switch at proper position, and determine the unknown frequency by the formula relating product divided by the difference of two adjacent frequencies. Thus, if one frequency of the generator reads 1,800 kc and the next adjoining generator frequency causing response with receiver unmolested reads 2,000, the unknown frequency is $1,800 \times 2,000$, or

"HAMS" ALERT OVER BOOTLEG 5-METER TALK

Since the promulgation of an order through the Communications Commission that 5-meter transmission and reception may be instituted on "mobile services," quite a business has sprung up in the sale of 5-meter sets for use on automobiles. Thus the amateurs who possess licenses may talk to one another over the short distances possible in this frequency spectrum, especially as the devices are compact and are both transmitters and receivers. By simply throwing a switch the circuit is changed from one for reception to one for transmission.

The so-called 5-meter transceivers are not calibrated, so there is the requirement that if transmission takes place that it be within the allotted spectrum. However, one is privileged to listen on any wave, therefore, lacking any measuring equipment one is ready and willing to take with him in the car to enable him to respect the stringent regulations for confinement within a band, transmission may be deemed to be passed up largely from cars, reception instead being the main attraction.

Hams Keen for It

When one gets home he simply lifts the little set out of the car, and, with measuring equipment on hand, say, a wavemeter, may cut loose on transmission.

Phone has been worked well in this band, and the amateurs throughout the country, if not throughout the world, are keen about this neighborhood gossip. A few miles is pretty good coverage. Up to 10 miles has been registered often, and freak examples of much greater coverage have been reported. The elevation of the transmitter has a great deal to do with the distance of penetration, because the higher it is the freer it is of intervening objects, which act as a damper on transmission, sidetracking the wave or erecting a "show wall" against it.

The frequencies are as high as the amateurs have gotten in a practical way toward those regions where waves behave somewhat in the manner of light, and intervening objects have somewhat the same effect on the radiation as they have on the radiant waves from the sun or the moon from the searchlight of the river boat.

Not Free-for-All

The 5-meter region is not a free-for-all, by any means, and transmission (but not reception) on this band, as on any and all other bands, requires a "ticket," as the hams call their licenses. Penalties for transmitting without a license include fine and imprisonment, so any adventurers who have been adding to the zest of picnics by installing a radio system worked between parked cars, or have been talking—via 5-meter waves—on the road, without that necessary ticket, are in danger. Amateurs feel there has been some such violation, and lest it redound to their discredit, for they are very particular about adhering to regulations, have caused warnings to be sent to editors that they should warn their readers.

3,600,000, divided by the difference, 200, so the unknown is 18,000 kc or 18 mcg. Taking 4,500 kc as the extreme and 4,450 kc as the next lower frequency accurately read, an unknown even higher than 400 mcg could be determined. The answer based on the two frequencies cited is exactly 400.5 mcg. That's in the centimeter-wave region.

A De Luxe Tuner

The Highly Individualized Mechanical Construction of Superheterodyne

By B. G. Valentine

QUITE a few radio experimenters build tuners, and work them with high-class power amplifiers. The tuner that I built takes more room than most complete sets, but it was built for the sole purpose of yielding maximum performance, and all possible pains were taken to make the mechanical result an excellent one, as well. As can be seen, some original mechanical design had to be used, and while the work of making the chassis, shield compartments, etc., took a great deal of time, the repayment in terms of satisfaction was complete.

The tuning coils themselves are in shields of the usual aluminum type, and besides are in the shielded compartments beneath the chassis. This proved efficacious as an elimination method where unwanted oscillation was concerned.

Intimacy of Controls

Then, too, whenever any adjustable part had to be used it was put as close as practical to the circuit affected, hence manual trimming condensers, volume control, etc., are not found some long distance back of or away from the tubes and parts that they serve. This bringing the control close to the circuit it governs is not often followed, as the tendency is to avoid mechanical work, long shafts, etc., and let the leads be long, which is not the better practice of course.

Nothing was spared by way of effort and expense, so a set that would work very well could be bought for less money, but not a set that would give the full satisfaction of this superheterodyne tuner.

Filtration at the radio-frequency and intermediate-frequency levels was carried out with a vengeance, not only in the cathode legs, where completeness is more important than some persons realize, but also in the screen and plate legs. Capacities were amply high, chokes of high inductance, and also of course voltages were carefully selected at the right value from the power amplifier, the B supply of which fed the tuner.

Security Observed

The circuit was equipped with a tuning meter, viewed through the upper opening of the specially-made escutcheon. A drum dial drove the four-gang condenser, which condenser was comprised of four separate singles, two united on one common shaft, on one side of the drum, and the two others on the other side of the drum by another shaft exclusively common to them. The National drum dial has set-screw for engaging the rods on both sides.

The two stages of intermediate-frequency amplification are coupled by doubly-tuned transformers put on top of the chassis, and the leads from the transformers to the grid caps in particular are very short.

The front-cover illustrations show the cabinet view. Herewith is the bottom view with cover removed. There are numerous tapped holes, as shown, these corresponding to somewhat wider holes in the bottom cover, for securely fastening the lower piece to this exposed bottom, to prevent

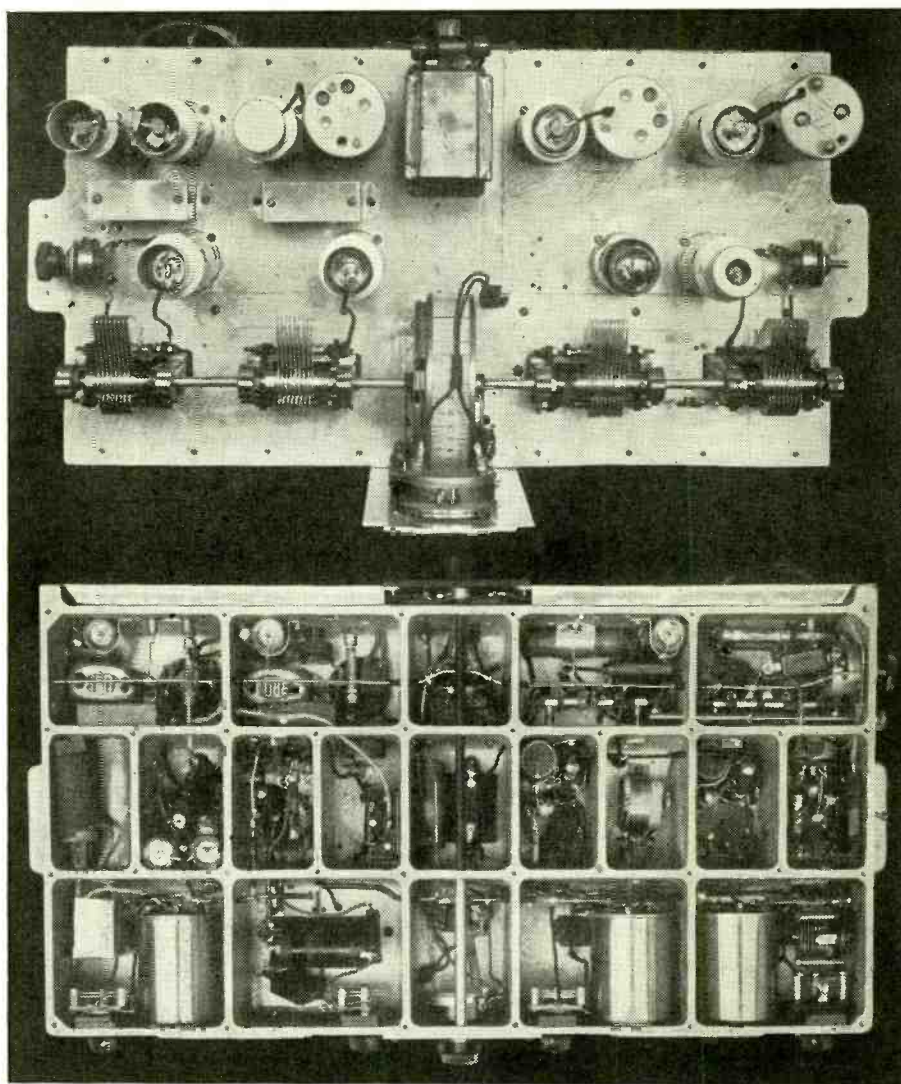

Top and bottom views of B. G. Valentine's tuner.

any possibility of vibration due to loose or uneven fitting.

Tubes and two single-setting variables are on top of the chassis, also, as shown on the front cover. The front view on front cover shows the appearance is quite presentable. All the front-panel controls necessary for proper operation, including maximum sensitivity, and overcoming of detracking at r-f levels, are included, and yet they are few enough not to be both bothersome.

(To be continued)

NATIONAL UNION HIRES MEN

National Union Radio Corporation of N. Y. announced the addition of four men to its field sales force. The newcomers have all had years of experience in radio. They are C. Davis, assigned to Oklahoma and adjoining states; Maitland K. Smith, who will cover North and South Carolina; Walter H. Tucker, who will travel the State of Ohio, and J. H. Klein, who will contact throughout the southern part of Texas.

New Zealand Erects "Distress" Network

Auckland, N. Z.

If ever another calamity befalls New Zealand a communications system will be ready to take up where a possibly destroyed line telephone system left off, for nineteen radio stations, besides additional branches, of a network have been established in conjunction with Post Office activities, and independent of the Government-owned broadcasting stations.

The experience of Napier three years ago, when an earthquake destroyed all normal means of communication, prompted the present move. At that time radio amateurs, who have become famous the world over for their emergency traffic in time of distress, took up the burden, and were aided by ships in port that were radio equipped. Only in that way was news of the seriousness of Napier's plight disseminated.

Relaxation Oscillations

Found in Dynatrons Under Some Conditions—Neon Tube and Other Negative-Resistance Generators Studied by van der Pol

By Edward C. Carter

A CLOSE analysis of non-linear theory of electric oscillations is made by Balthasar van der Pol in the September issue of "Proceedings" of the Institute of Radio Engineers, the treatment being mathematical and the discussion exceedingly detailed.

Since 1920 the growth of information about non-linear oscillations has been rapid, and besides his own contributions Mr. van der Pol reviews papers published in scattered journals throughout the world, and prints a comprehensive bibliography at the end of his article.

The non-linear condition at first was regarded of little or no importance, but gradually grow to great importance as the facts concerning it were developed, since so many oscillators are satisfactorily explained only on that theory. In fact, the linear theory was followed for a long time as a convenient one though applied to non-linear circuits, leaving much to be desired in the way of complete results.

Relaxation Oscillators

The author treats very interestingly of the relaxation oscillator. As long as the oscillation has a small amplitude the relative change in the amplitude during one oscillation is small compared with unity.

The relaxation oscillator is familiar to many in the form of the glow-discharge tube, such as the neon and argon tubes, where a voltage is impressed on a series circuit consisting of a resistor and the lamp, while across the lamp is a condenser. This condenser is constantly discharging, and the period of oscillation is related to the time constant of the resistance and the capacity. When the condenser is across the lamp the condition of small relative change in amplitude usually occurs, whereas when the condenser is across the limiting resistor the amplitude becomes tremendously larger. Of this fact he does not treat, but he does show the difference of effects when amplitudes are large and when they are small.

When the amplitude is small the oscillation builds up slowly and the wave form is substantially sinusoidal. The term "relaxation oscillator" therefore is applied more suitably to circuits where the amplitude is large.

Wave Forms

Many harmonics of considerable amplitude are present in the relaxation oscillator of the medium or large-amplitude class. The medium amplitude type develops something like saw-tooth wave form, and the maximum amplitude type something not far from flat-top wave form. The author shows curves.

He says:

"Characteristic of a relaxation oscillation is the fact that during the greater part of the period the phenomenon has typical aperiodic or asymptotic behavior (such as shown by the well-known intermittent discharges of a neon tube shunted by a capacitance and fed by a battery

through a resistance), and thereupon suddenly the system becomes unstable and the disturbance jumps rather discontinuously to another value, and then the same discharge phenomenon repeats itself all over again, etc., so that a relaxation oscillation has the character of an ever-repeating discharge phenomenon. Therefore the time period is given by the relaxation time such as CR ."

C is the capacity and R the resistance.

Sees Wide Possibilities

The following interesting observation is made by the author:

"Many more instances of these oscillations can be cited, e.g., the beating of the heart with its many anomalies showing aborigine frequency demultiplication is typical in this respect. Also it seems that many aerodynamic phenomena associated with eddies are of this nature. Even the periodic reoccurrence of economic crises and epidemics may possibly follow similar laws. Further, the periodical electrical disturbances generated in a nerve by a constant stimulus are of a nature of relaxation oscillations. In general it appears that many periodic phenomena for which an explanation on the basis of sinusoidal oscillations fails to give a satisfactory explanation can be better studied from the point of view of relaxation oscillations."

He treats also of the cases of the dynatron and the multivibrator. The dynatron is usually circuited with a screen-grid tube of the type having no suppressor. This tube, when the plate voltage is critically lower than the screen voltage, has a negative resistance characteristic, like the glow-discharge tubes, and may be used as audio oscillator or radio-frequency oscillator. For r-f oscillations the plate circuit is tuned. The author found that for very small capacity in the tuned circuit the oscillations are of the relaxation type, but that for larger capacity the oscillations come much closer to the sinusoidal type, for the dynatron.

The Multivibrator

The multivibrator consists of a two-tube resistance-coupled circuit, with output of the second tube fed back to the input of the first tube. Thus oscillation is introduced, and the time constants determine the frequency of oscillation.

The equations for oscillations of all types discussed are given and intimations as to conditions of stability or instability are set forth.

"A Short-Cut Method for Calculation of Harmonic Distortion in Wave Modulation" is the title of an article by I. E. Mouromtseff and H. N. Kozanowski, of Westinghouse Research Laboratories, East Pittsburgh, Pa. The method applies to precalculation of harmonic distortion in a Class B audio amplifier. This of course is a push-pull circuit, and the even order harmonics do not appear, and therefore need not be considered. The odd order harmonics are analyzed by graphical representation of the grid-volt-

age, plate-current characteristic, and drawing a straight line (chord) between the two extreme negative and positive points. The departure of the actual characteristic from the straight line discloses the amount of distortion. Each harmonic of an odd order is treated separately to derive the result, measurements having been made up to the eleventh harmonic. The measurement of the ordinate differences between the curve and the chord for five definite values of abscissas yields the result. Simple expressions allow for rapid calculations.

L. V. Berkner and H. W. Wells, of Carnegie Institution of Washington, Washington, D. C., report on ionosphere investigations at the Huancayo Magnetic Observatory, Peru, during last year.

The state of the upper stratosphere in Polar regions is discussed by M. A. Bontch-Bruewitch, Institute for Scientific Research, Leningrad, U.S.S.R.

Thanks Given to 14 Stations

Radio stations in fourteen midwestern cities received from George McElrath, NBC operations engineer, souvenirs of the recent National Geographic Society-Army Air Corps stratosphere flight and letters thanking them for their cooperation in the broadcasts.

Special equipment was installed by each of these stations at points outside the cities in which they are located so that messages from the balloon might be picked up with maximum strength and relayed to NBC networks in the event that the big bag drifted toward the station's particular area or landed near its city.

Every day during the five weeks of preparation for the flight the fourteen stations conducted tests with the NBC camp at the stratosphere bowl near Rapid City, S. D. Here equipment identical with that used in the balloon was set up under McElrath's supervision. The stations, through the tests, were able to adjust their receiving equipment so that messages from the stratosphere could be brought in clearly and completely.

The stations which aided in making the flight broadcast one of the outstanding radio features of the year were KFYY, Bismark, N. D.; WDAY, Fargo, N. D.; WHO-WOC and KSO, Des Moines, Ia.; WREN and WDAF, Kansas City; KWCR, Cedar Rapids, Ia.; WLW, Cincinnati; KOA, Denver; KSTP, Minneapolis; WKY, Oklahoma City; WOW, Omaha; WSM, Nashville, and KWK, St. Louis.

Quietus on New Tubes

More and more combination tubes are announced. About half the new ones have been of that type recently. It is said that there will be no new tubes announced for at least several months.

Radio University

Unexpected Oscillation

RECENTLY I had a funny experience that seems to go contrary to what is expected. I built a signal generator in a metal cabinet. To this cabinet was attached the metal chassis. The oscillation transformer was placed close against the bottom of the chassis and was close to the rear metal wall of the chassis, as well. I put in the tickler and the generator oscillated. Then I reversed the tickler, which was loosely coupled, and still there was oscillation. I am familiar with the phenomenon of oscillation with reversed tickler at the higher frequencies of tuning, due to the capacity effect in the tube, or the oscillator changing its nature, but here was an instance of oscillation retained all over the dial. Now, how do you account for that?—B. H.

This is due to the effect of the metal as a shield or refractor upon the magnetic lines of the flux. Instead of the usual concentric lines of force you produce bent lines, and therefore a sufficient number of lines of force are traveling in reverse, hence if you put the tickler on one way you get oscillation because there is enough positive feedback due to some of the lines of force, and when you put the tickler on the other way (or reverse the connections, which amounts to the same thing) there are still enough reversed lines of force to sustain oscillations.

Transmitter at College

NOW THAT I am going back to college I would like to operate my amateur station there, but as I am at college eight and a half months a year, I don't see how I can operate the station there on a temporary license which, I am told, is in general good for only three months, unless a special authority is obtained for extension. I do not want to give up my transmitter and operator's license as now held from my home address, yet I would like to work the station at school.—T. H. C.

The location at your home could be used for a temporary license and a permanent license obtained possibly by transfer for the school location. Thus you would be listed as at the school for the permanent license and as you would be home in Summer only about three months you would come under the temporary classification there. After you have finished college you could have the permanent licenses retransferred to your home address. For details address the Federal Communications Commission, Washington, D. C.

The 58 Requirements

MAY THE 58 be used as a dynatron, and can the heater voltage be positively biased in respect to the cathode?—H. W. S.

The 58 is not suitable as a dynatron oscillator, due to the presence of the suppressor. Even if this suppressor is grounded, the same advice holds. The 24 in this class of tubes will serve the dynatron purposes nicely. The d-c point to which the heater should be connected should never be positive. It may be zero, or it may be negative, up to about 50 volts. Whenever it is necessary to have the negative d-c potential anywhere nearly as high as 50 volts, when connected to the heater, put a very large capacity from heater to ground, say, 4.0 mfd. or more, as a precaution against hum modulation.

Different Speaker Field

SOME OF THE CIRCUITS I see published call for dynamic speakers of differ-

ent field ohmages than the speaker I have, which has 2,500 ohms d-c resistance. Often the diagram calls for 1,800 ohms, with a tap. Can my speaker be used nevertheless?—U. D.

Yes, it can be used, if you are willing to have the voltages lower than what otherwise would be present, that is, lower than rated voltages. For instance, if a receiver normally draws 60 milliamperes of B current, and the field is 1,800 ohms, the drop across the field will be 108 volts. If bias is obtained from a tap at 300 ohms for a single pentode, then the bias voltage will be 18 volts. Your speaker, with higher field resistance, will drop more voltage, but at the same time the current drawn by the tubes will be somewhat less, so the drop is not quite proportionate, for the current has changed. That much is in your favor. But you might well expect to drop 125 or 130 volts, and if the original supply was 300 volts, you would have left 175 or 170 volts, instead of the expected 200 volts. The difference is not enough to stop the set from playing and if you want to use the speaker, that can be done. As for the bias, if you will measure the voltage drop across the field, you can select two high resistances, proportioned according to the required proportion of voltages, and put resistors in series across the field, lower resistance to ground, and connect grid return of the power tube to the joint of the two resistors. If the total voltage drop across the field is 120 volts, and the bias is to be 18 volts the resistors may be 200,000 ohms and 33,000 ohms. Across the 33,000 ohms put a condenser of 0.1 mfd.

Number of Sets in Use

THE STATEMENT has been made that the United States has more radios

than all the rest of the world put together. Is this so?—I. H.

No, it is not quite so. The United States Department of Commerce reports that there are 42,500,000 receivers in the world, of which 18,500,000 are in the United States. Therefore the United States has the greatest number, though not quite as many as the rest of the world put together. The United Kingdom is second with 6,130,000, Germany third with 5,434,000, Japan fourth with 1,729,000, France fifth with 1,550,000 and Canada sixth with 1,000,000.

Noise-Suppression Control

DOES the noise-suppression control actually make a set more selective, or does it just have the appearance of so doing? Is n.s.c. free of distortion?—G. C. S.

The noise-suppression circuit does not change the selectivity of the set, which depends on the tuning done and the coupling, but it does give the appearance of improving the selectivity, because reception a bit off resonance is blotted out, and stations pop in and out with seemingly great selectivity. We cannot say that the system is free of distortion, but if operation is under conditions when the squelch circuit is not contributing much, there should be hardly any distortion, but when the squelch starts to work, it naturally produces distortion, as it is just like adding the effects of another detector tube to the circuit. The squelch tube itself naturally must be worked in a distorting portion of its characteristic if it is to be effective. We never were sold on the n.s.c.

Television Modulation

FOR THE ATTAINMENT of suitable modulation of a very high frequency carrier for television, what modulation would you suggest? Would the Heising system be applicable?—J. B.

The method most often recommended is the use of series modulation. That would rule out the Heising system, which is a shunt feed of the audio to the plate circuit of the radio tube. The series con-

(Continued on next page)

Two Almost for the price of One

Radio World is \$6.00 a year (52 issues). Read the following Combination Offers for Radio World and other worth-while publications for one full year on each offer.

- RADIO WORLD and SHORT-WAVE CRAFT, \$7.00.
- RADIO WORLD and POPULAR SCIENCE MONTHLY \$6.50.
- RADIO WORLD and RADIO-CRAFT (monthly, 12 issues) \$6.50.
- RADIO WORLD and RADIO INDEX (monthly, 10 issues), stations, programs, etc., \$6.35.
- RADIO WORLD and RADIO (monthly, 12 issues; Short Wave and Experimental) \$6.60.
- RADIO WORLD and EVERYDAY SCIENCE AND MECHANICS (monthly) \$6.50.
- RADIO WORLD and RADIO LOG AND LORE. Bi-monthly; 5 issues. Full station lists, cross indexed, etc., \$6.25.
- RADIO WORLD and AMERICAN BOY - YOUTH'S COMPANION (monthly, 12 issues; popular magazine) \$6.50.
- RADIO WORLD and BOYS' LIFE (monthly, 12 issues) \$6.50.
- RADIO WORLD and MOTION PICTURE MAGAZINE (monthly) \$6.50.
- RADIO WORLD and MOVIE CLASSIC (monthly) \$6.25.
- RADIO WORLD and SCREENLAND (monthly) \$6.50.
- RADIO WORLD and SILVER SCREEN (monthly) \$6.25.
- RADIO WORLD and OUTDOOR LIFE (monthly) \$6.50.
- RADIO WORLD and THE PATHFINDER (weekly) \$6.25.
- RADIO WORLD and TRUE STORY (monthly) \$6.50.
- RADIO WORLD and LIBERTY (weekly) \$6.50.

Select any one of these magazines and get it for an entire year by sending in a year's subscription for RADIO WORLD at the regular price, \$6.00 plus a small additional amount, per quotations above. Put a cross in the square next to the magazine of your choice, in the above list, fill out the coupon below, and mail the quoted price by check, money order or stamps to RADIO WORLD, 145 West 45th Street, New York, N. Y. (Add \$1.50 for extra foreign or Canadian postage for both publications.)

Your Name..... **DOUBLE**
 Your Street Address..... **VALUE!**
 City..... State.....

- If renewing an existing or expiring subscription for RADIO WORLD, please put a cross in square at beginning of this sentence.
- If renewing an existing or expiring subscription for other magazines, please put a cross in square at the beginning of this sentence.

RADIO WORLD, 145 West 45th Street, New York. (Just East of Broadway)

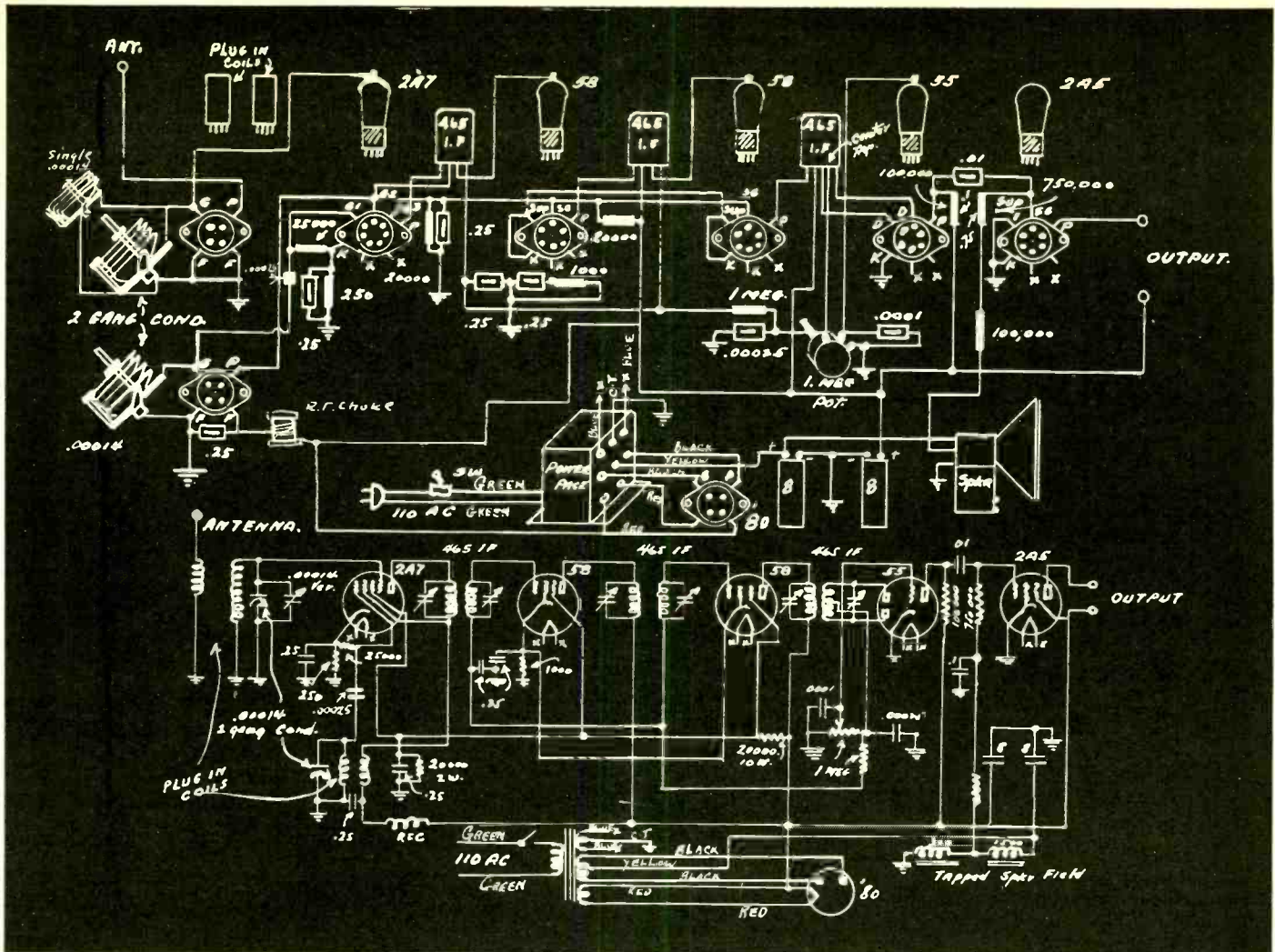

Using plug-in coils, this circuit covers the short waves. Both the pictorial and the schematic wiring diagrams are given in response to a request from T. C., whose question is printed on this page.

nection is recommended by television experimenters who have tried various methods and report that they get good results only in the series manner. The series method would consist of having load for the plate or other circuit of the oscillator open at one end, and introducing the television frequencies through a load which completes the return. Besides modulation, the method of radiation presents something of a problem. Short projecting wire often is used, sometimes only a few inches, with an exact counterpart at the receiving end, for work over short distances.

Short-Wave Super

WILL YOU PLEASE show a pictorial diagram of a short-wave receiver, using plug-in coils, for superheterodyne operation, and give particular attention to the hookups of the speaker?—T. C.

The pictorial and schematic wiring diagram of such a circuit are shown herewith. The values are imprinted. The speaker consists of a field coil of 1,500 ohms, tapped at 300 ohms (1,200 plus 300), an output transformer, a voice coil, cone, etc. Only the field and the transformer primary require connections externally. You should check the speaker field by measurement with an ohmmeter. The resistance between tap and extreme that measures 300 ohms is used for bias, extreme going to ground, tap to grid return (through the resistor-capacity filter in the diagram). The secondary of the output transformer is connected to the voice coil in the speaker, hence you don't have to do anything about that, but the primary must be connected to the points marked "out-

put." If hum is troublesome, try reversing the connection of the speaker transformer primary to these output posts. Sometimes the B plus voltage for the power tube, etc., is connected inside the speaker to the end of the field coil, though this is rare these days. In such an instance you would have to sever this connection and bring out five separate leads, for use of the field in the negative leg of the rectifier. The field coil is also the B supply choke.

U-F Measurement

CAN THE ultra frequencies be measured by means of absorption type wave-meters, and would a plate milliammeter be a suitable indicating device?—J. M.
Yes to both.

Radiation

DO LOCAL OSCILLATORS in superheterodynes radiate, or is the present use of shielding sufficient?—T. D. S.

Many of the local oscillators radiate. The shielding is usually insufficient by far. The introduction of the pentagrid converter tubes reduced this radiation nuisance somewhat, because of the concentration of the wiring in a small area, instead of being spread out to pick up connections to a couple of tubes.

Auto Set Troubles

CAN RADIO-FREQUENCY troubles be simply eliminated from the ignition system of an automobile?—K. E.

The best method found so far is the complete shielding of the ignition system to prevent radio-frequency interference

being picked up by an auto set. Cure of the trouble in the receiver proper does not seem to be such a simple matter for r.f., although for a.f. a cure can be applied right in the set. As a substitute for the completely-shielded ignition system, filters may be used, consisting of resistors and condensers. Resistors are commonly used in the leads from the plugs and a condenser put across the commutator.

Frequency Standard

PLEASE STATE AGAIN details of the standard frequency transmissions of the Bureau of Standards.—P. O'R.

The Bureau of Standards transmits 5,000 kc from WWV, Beltsville, Md., every Tuesday, except on legal holidays, continuously from noon to 2 p.m. and from 10 p.m. to midnight, Eastern Standard Time. The accuracy of the frequency of transmission is at all times better than one cycle per second (one part in 5,000,000). For the first five minutes the general call (CQ de WWV) is sent out in code, and code announcement of frequency is transmitted, the frequency and call letters being given every ten minutes thereafter. The main portion of the transmissions consist of continuous unkeyed carrier wave. Information on the utilization of these signals is given in a pamphlet obtainable from National Bureau of Standards, Washington, D. C.

Demodulated Carrier

IS THE DEMODULATION of a broadcast carrier for use as a standard high-

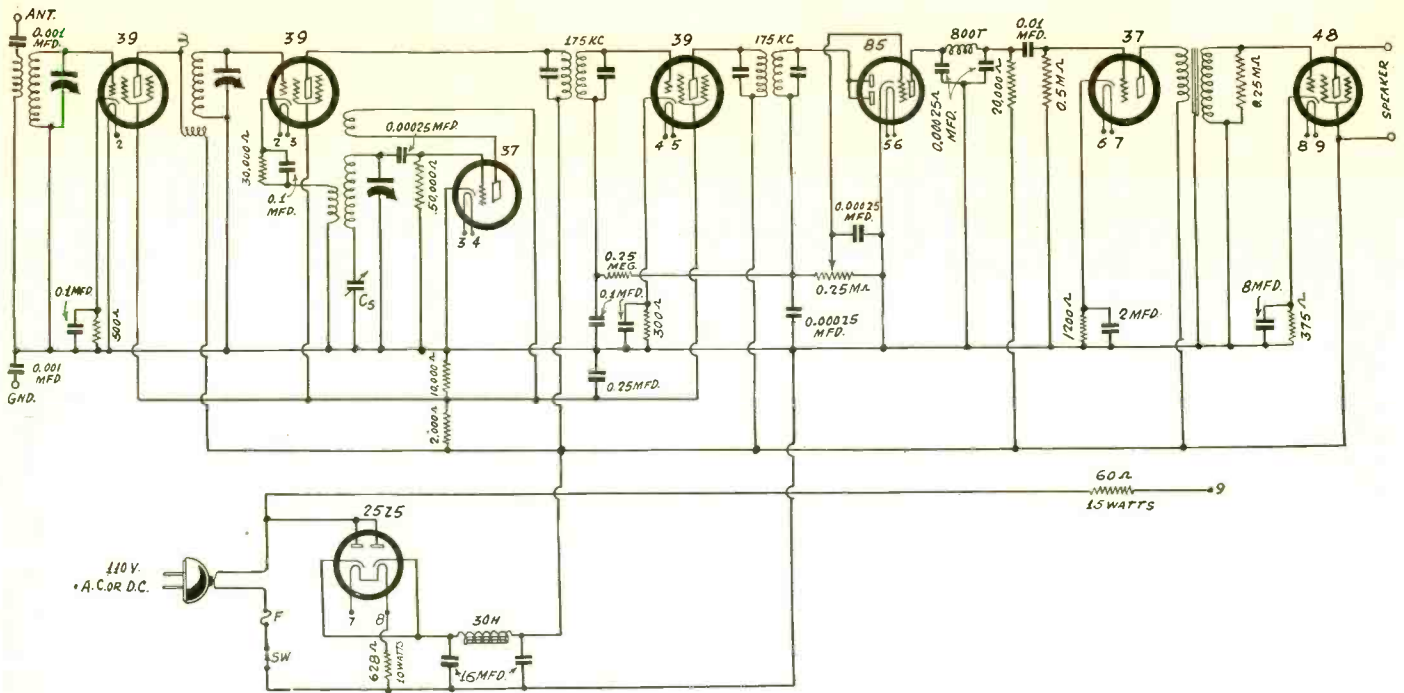

A superheterodyne with 48 output tube, in a universal circuit. The current in the networks associated with the heaters is equalized by a shunting resistor. A way some prefer is to have the 48 independently served, as then the life of the other tubes is preserved. See the answer to question put by W. D. C.

frequency source a difficult matter? I find that the modulation of the broadcasting station interferes with exactness in the zero-beat tests I try to make.—O. K. C.

It is a very simple matter to gain the result equivalent to demodulation of the broadcast carrier. There are more complicated and perhaps better ways, but you will find that if you use a very short antenna, perhaps only the lead run from the output of your test oscillator to the set, or maybe a little more wire than that, if the station is weak or set not very sensitive, that you can bring in the carrier without hearing the modulation. To the same effect a small series antenna condenser could be used, and adjusted to the conditions required by the field strength that the station lays down at your location. Since the modulation cannot be heard, except perhaps on very sensitive earphones, you will not be able to tell that you have tuned in the station, but the generation from your oscillator will produce a beat that you will hear nevertheless in the receiver's reproducer. This method is practical because the modulation average is never equal to the average amplitude of the carrier. Very accurate determinations may be reached in this way, especially if the test oscillator is unmodulated.

* * *

Possibilities of a Novelty

SOME TIME AGO you printed a circuit showing how the carrier was reduced to audio frequency, then the audio impressed on an oscillator, then the audio amplified at what would now be a supermediate frequency. Will you please tell me what is the trouble with the circuit, as it seems to me to have possibilities?—K. L.

We do not deny the possibilities of the circuit, which is printed herewith. The first tube is a regenerative detector, and reduces the modulated carrier to its audio values. We now have audio frequencies in current form just as they are present in the output of a microphone at the station, hence can treat them the same way. What does the station do but impress these audio frequencies on a carrier? We generate a carrier in the triode of the 2A7, and introduce the audio from the preceding tube to the control grid of the

2A7. Now we have put both frequencies into one tube and the electron coupling takes care of the mixing. The output of the 2A7 is both audio and radio, but the audio has no path and is shorted, so the radio goes on and may be amplified and second-detected as usual. The trouble experienced with the system is that it is hard to have the local oscillator going strong, and avoid causing it to drive the intermediate channel (or supermediate channel, you would say) into oscillation. This is because, unlike the case of the standard superheterodyne, where the oscillator is at a different frequency by far than the i.f., the i.f. and oscillation frequencies are the same. No matter how much tuning is present in the i-f channel, the selectivity is not aided, except what might be called audio selectivity, for any interference that got into the regenerative detector stays right on, being part of every form of what follows. The so-called audio selectivity arises from the fact that the i-f channel may be made to cut off all above 8 kc, then any interference outside the limit frequency would not be heard, but the same effect could be attained with a higher than usual value detector bypass condenser in the demodu-

lator output. The system is very interesting, but whether it is of much practical value we are not at all convinced. We have tried it out several times, once with great patience.

* * *

Circuit for the 48

HOW CAN the extra current required for the 48 be taken care of, where the other heater type tubes in a universal set are of the 0.3 ampere type? I understand the 48 is a remarkably sensitive tube, and puts out a lot of power, low d-c voltage considered, but that the heater current is 0.4 ampere. Please show in the diagram a superheterodyne with three tuned circuits, plus one intermediate amplifier and three audio stages.—W. D. C.

The 48's requirement can be taken care of by having a common limiting resistor, and shunting the series chain of 0.3 tubes with a resistor to take up the current difference between one side of the circuit and the other. Thus in the diagram the 628-ohm, 10-watt resistor is the shunting element. The series limiting device is the 60-ohm, 15-watt resistor.

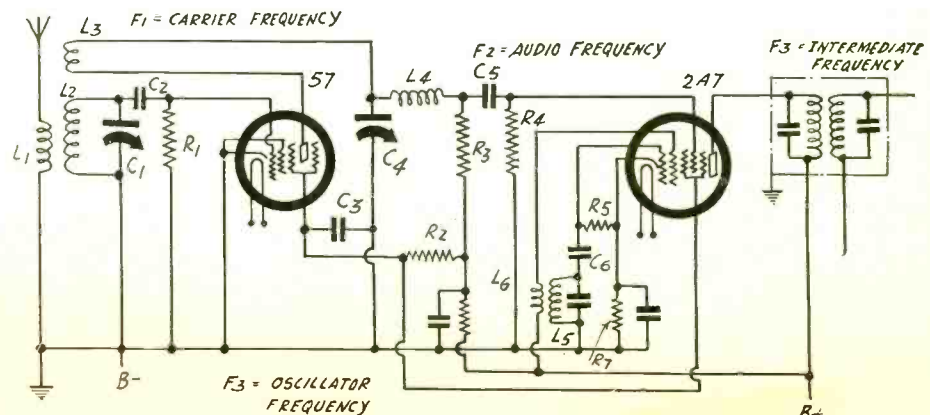

The limitations of this interesting circuit are discussed in answer to K. L.'s question about the audio component of a regenerative detector being used as modulation current or voltage in a second oscillator circuit, so that at the new frequency further amplification can take place.

POLICE STRIVE FOR SECRECY IN AIR MESSAGES

The police radio services are finding it advisable to use secret codes for transmission of their messages. The police departments in some of the cities and States have developed such codes, some of them using simply numbers, so that, although the fun of listening to police broadcasts is thereby eliminated, the officials state that the serious work at hand is better performed.

It is the contention of practically all the police departments that if a message is sent out in "the common tongue" the person or persons in the act of committing a crime easily could be forewarned that the police are on the way. For instance, if some one spies a man breaking into a factory at night, and telephones the police, a message flashed in ordinary language to the police cruisers, as the radio cars are called, could be picked up either by the culprit himself or by a confederate in an automobile. Then the getaway would be easy.

Fire Fighters Follow Suit

Fire departments of some of the cities also use radio on occasion for co-operative effort in coping with a large fire. So do the forest fire-fighters of the United States Government. All this work of protection of life and property, including even the activities of health departments, comes under the general legal classification of "police power." That is, policing does not apply only to preventing and detecting crime and making arrests.

The United States Forest Service finds that its activities have not been helped by listeners, and is the latest to develop a code. The radio service of this branch of Federal activities is much more important and extensive than most persons imagine, as there are already 600 installations, with more in prospect, and experimentation going on all the time. A laboratory in Vancouver, Wash., is constantly trying to improve the transmission and reception. Both international Morse code and voice are used, but the code referred to above applies to voice with enigmatical significance attaching to the utterances.

Must Avoid Static

Much of the trouble with which the Forest Service must concern itself takes place during storms, therefore receivers with a very low noise level are necessary, for it is imperative to override the static considerably. Therefore waves are preferred that are so short that the static effect is low indeed.

Telephone lines are usually employed in connection with fire-fighting by the national service, but the radio is relied on for emergency work. This application of radio to emergencies is growing throughout the world, a recent addition having been the institution of several radio installations in telephone exchanges by the New Zealand government. Earthquakes may cut off all means of communication by mobile and line methods, so radio is relied on to inform the world of any local plight, and carry the plea for assistance.

HARRINGTON AT KWK

John Harrington, who for the past year and a half was announcing for WGN, Chicago, has returned to St. Louis to assume the duties of assistant manager in charge of production at KWK.

THE WEEK IN TECHNIQUE

By *Herman Bernard*

The Actual Showing Counts

THE exhibition room is the best battleground for the television debate. Conflicting theories are entitled to their place in the sun until television becomes commercially practical, and even thereafter, but the basis for immediate determinations is what is shown. Recently two methods have been exhibited, and previously there were private showings of the RCA-Victor system.

The present stage of development is that small-sized projected pictures are pretty good. There is no serious attempt to encompass the severe demands of the theatre-sized screen, for the smaller dimensions must be covered first with legible and entertaining subjects. Plenty of illumination has to be provided even for the home-movie size projections of television, and few demonstrations indeed show pictures of that dimension.

Nevertheless, practical television for public entertainment is much nearer than many are willing to admit. The trouble has been too much optimism in the past. Nobody wants to risk any prophecy of "television next year," in the light of the disappointments of similar prophecies during the past six years.

But the advances have been steady and notable. Even scientific achievements made in devices that themselves do not yet provide sufficient illumination can be admired.

At present the principal debate is between the exponents of the cathode-ray tube for scanning, and some mechanical system. The fact that strikes most observers is that much illumination is needed and the cathode-ray doesn't seem to provide enough of it. Yet mechanical systems are made with accompanying light-using devices where the illumination is good. The first round goes to the mechanical system. But the fight is not yet over. Nor will it be another ten-year struggle. It will be possible within the next year for small stations to put television on the air at an initial expense of \$5,000.

Not until something is sent can anything be received. And then suitable sets and receiving scanners will have to be produced. The large chains are very unlikely to provide the impetus. They are extremely conservative, have had some disappointments and large expenses in these very endeavors (though on a strictly experimental basis) and will let the smaller stations, which they deem have less prestige at stake, pave the way.

* * *

Better Sets

RECEIVER manufacturers have made up their minds to turn out sets of superb acoustical excellence. That is a fine move. It can not be said that the manufacturers in the past, as a whole, have done such an excellent job. Until only a few years ago they were far behind the possibilities of tonal excellence, and even produced receivers, probably knowingly, that did not meet selectivity and sensitivity requirements even within the legal capabilities of the time to fill such needs. The first commercial receivers were outrageous. For years their successors were not much better. The atrocities seemed to sell better than the superior sets.

Radio receivers are more important to the public than the receiver manufacturers as a whole seem to have realized. Any manufacturer with a respect for performance, hence with respect for the public, would not put

out in party packages these small receivers that do practically nothing, except bring in a few locals poorly. The public has been, in many instances, encouraged to accept the worst, the price level of sets therefore dropped to a point indicative of what was being inflicted on the public, and if there is a present trend to make amends, the manufacturers and the public will benefit. If the public did not have so much junk thrust at it, the public would not buy so much junk.

* * *

Relaxation Oscillators

CONSIDERABLE attention is being given to relaxation oscillators. These are generators that work by virtue of their negative-resistance characteristic, such as neon and argon glow-discharge tubes, and the like. The 82 and the 83 mercury-vapor rectifiers also have that characteristic, and conceivably could be used as such oscillators.

One of the interesting experiments is to get the tube to oscillate at a relatively high frequency. So far around 100 kc is stated as the practical limit. Another interesting determination would be, when a circuit is hooked up as audio oscillator, if the same frequency will be generated if another similar tube is substituted. That is, experimenters are interested in whether the tubes' characteristics, in production, are controlled closely enough. Evidently there is some trouble, because in a few of the semi-critical uses of glow-discharge tubes in receivers, as level indicators or tuning aids, lamp trouble has been experienced. The test applied is that the lamp should not glow below a certain voltage—say, 52 volts—and should not require more than a certain maximum for ignition. However, if within any specified limits a test like that can be applied, it would be easy enough to select a good tube, if the same frequency then would be generated, for the glow-discharge tubes offer immense advantages as audio oscillators, for simplicity, compactness and economy.

Owners of Broadcast Sets Wonder About Short Waves

There are many who have broadcast sets with which they are satisfied. Some of them paid a good deal of money for these receivers. Now that interest in short waves is growing fast, some owners of these good sets wonder what they can do about bringing in those newly fascinating waves.

One solution is to use a short-wave converter, a device that changes the short waves to a single frequency that the receiver can amplify. But the converter must be a good one, expertly designed. In fact, the best of them are those designed to work with a particular receiver, and one manufacturer has such a model evidently brought out principally to answer the demand of owners of expensive broadcast set for short-wave results.

Another way is to have a set that brings in only short waves, to supplement the broadcast receiver. If this is done it is practical to use a rather high intermediate frequency, say, around 1,650 kc, and then there should be no trouble with images even if there is no pre-selection ahead of the tuned modulator. Although little has been done with a high i.f., no doubt in days not far distant we shall see numerous receivers of that type.

RADIO AIDS JUSTICE

Various radio and acoustical devices, as well as relays, are used by police departments throughout the world, although little is said about such uses, on the supposition that any exposition would be more help to criminals than to law-abiding citizens. Photo-electric cells play their parts as spies, noting the going and coming of persons of various heights and "thickness," also the color clothes worn. Telephone conversations are subjected to scrutiny, all automatically, and banks have acoustical and visual alarm systems.

N. Y. EXPOSITION OPENS SEPT. 19 LASTS 12 DAYS

The second annual combined National Electrical and Radio Exposition opens at Madison Square Garden at 2 p.m. on Wednesday, September 19th. Until the exhibit closes, eleven days later, the public will be admitted from 11 a.m. to 11 p.m. to view the latest offerings of manufacturers, including receivers, electrical devices, accessories and equipment for the home.

One hundred and ten exhibits will be on display, making the coming show the largest ever held by the two industries, according to Col. John Reed Kilpatrick, president of the Madison Square Garden Corporation, managing the exposition as sponsored by the Electrical Association of New York. Four leading utilities and twelve publishers of magazines are included among additional exhibitors.

"Days" Announced

The United States Army, the new Federal Home Administration, New York Police Department, Michigan State Police Department, New York Museum of Science and Industry, New York Federation, Boy Scouts of America, New York Board of the Y.M.C.A., National Broadcasting Company, Columbia Broadcasting System, American Amateur Radio Relay League, New York Electrical League and other organizations will have exhibits.

Earl Whitehorne, chairman of the Show Committee and vice president of McGraw-Hill Corporation, announced the general program for the exposition with the naming of the eleven show days as follows:

- Wednesday, Sept. 19th—Electrical and Radio Program Day.
- Thursday, Sept. 20th—All Wave Radio Day.
- Friday, Sept. 21st—Army and Navy Day.
- Saturday, Sept. 22nd—Lighting Day.
- Sunday, Sept. 23rd—Broadcast Day.
- Monday, Sept. 24th—American Home Day.
- Tuesday, Sept. 25th—Police Day.
- Wednesday, Sept. 26th—Science Day.
- Thursday, Sept. 27th—Weather Control Day.
- Friday, Sept. 28th—Health Day.
- Saturday, Sept. 29th—Exposition Day.

Seats for 500

Two crystal broadcasting studios will be erected in the Garden and radio programs will be linked with nearly 200 stations daily from 2 p.m. to 11 p.m. National and Columbia networks and such local stations as WMCA, WOR, WINS, WNYC, WNEW, and WHOM are contributing

115 DIAGRAMS FREE

115 Circuit Diagrams of Commercial Receivers and Power Supplies supplementing the diagrams in John F. Rider's "Trouble Shooter's Manual." These schematic diagrams of factory-made receivers, giving the manufacturer's name and model number on each diagram, include the MOST IMPORTANT SCREEN GRID CHANGES.

The 115 diagrams, each in black and white, on sheets 3 1/2 x 11 inches, punched with three standard holes for loose-leaf binding, constitute a supplement that must be obtained by all possessors of "Trouble Shooter's Manual," to make the manual complete.

Circuits include Bosch 54 D. C. screen grid; Bellini Model F Crosley 10, 31, 33 screen grid; Eveready series 50 screen grid; Erie 124 A.C. screen grid; Peerless Electrostatic series; Philco 76 screen grid.

Subscribe for Radio World for 3 months at the regular subscription rate of \$1.50, and have these diagrams delivered to you FREE!

Radio World, 145 West 45th St., New York, N. Y.

the necessary talent, with the cooperation of special program sponsors.

Most of the famous radio stars will be heard and seen through the glass of the Garden studios at some time during the show, according to Joseph Bernhart, managing director. As many as 2,500 persons may see each radio studio performance where only a few hundred can by special invitation see a broadcast in the regular station studios, he states.

A band of seventy-five musicians will perform each afternoon and evening. Seats for 500 listeners will be provided.

Arthur Moss Appoints Palmer Sales Manager

George E. Palmer has been appointed general sales manager of Electrad, Inc., 173 Varick Street, New York City. Arthur Moss, president, said:

"Mr. Palmer brings with him a record of accomplishment and many years of experience in the radio industry, having served as general sales manager for approximately five years with the Dubilier Condenser Corporation. He was also connected in a sales capacity with the old Daven Radio Company of Newark and the Federal Telegraph Company of Newark.

"Being both a mechanical and an electrical engineer Mr. Palmer is fitted to further build up the good will that our company enjoys, both from a general sales point of view as well as in a technical capacity.

"We naturally are very happy to have been able to obtain the services of Mr. Palmer and feel that this connection offers greater co-operation to our customers and other friends throughout the country."

Neon Pilot Lamps Good for Battery Receivers

Users of battery sets sometimes wonder what to do about a pilot lamp. There is a special one made that draws 0.06 ampere, the same current as do the 2-volt series tubes, with few exceptions. However, an extra 0.06 ampere also is something to think about, especially if dry cells constitute the A battery.

If the B voltage is 90 volts to 135 volts, a neon lamp with suitable limiting resistor may be used. This shows enough light. For 90 volts the resistor normally is 200,000 ohms, for 135 volts it should be 250,000 to 300,000 ohms. If the resistance is a bit too high no harm is done. If it is much too low the lamp life will be short. The lamp does not actually burn out. It just stops lighting. The gas that is broken down to cause illumination simply isn't there any more.

DE LUXE COILS FOR SHORT WAVES

As fans and experimenters become more and more interested in short waves and learn more about their reception, they become harder to please in the matter of coils. They have found by actual experience that the best of sets, built with the finest of parts, become "weak sisters" unless the coils are also of the best. To those who realize this, we offer our De Luxe coils. We believe that the most critical will find these coils highly satisfactory.

The De Luxe Coils are of two types—the standard enamel wound coils, and the super-sensitive coils wound with silver ribbon. Both types are expertly designed and manufactured strictly in accordance with the design specifications. These coils are in sets of four to cover the entire short-wave band. Both come in four-pin for RF stage and six-pin for the intermediate stage.

Enamel wound coils:	Silver ribbon wound coils:
—four-pin	—four-pin
—set of four..... \$2.25	—set of four..... \$3.00
—six-pin	—six-pin
—set of four..... 2.50	—set of four..... 3.50

SCREEN GRID COIL CO.

143 W. 45th St., New York, N. Y.

"RADIO TROUBLE SHOOTING," E. R. Haan. 361 pages. 300 illustrations. \$3. RADIO WORLD, 145 W. 45th., N. Y. City.

Literature Wanted

Readers desiring radio literature from manufacturers and jobbers should send a request for publication of their name and address. Address Literature Editor, RADIO WORLD, 145 West 45th Street, New York, N. Y.

Ray Boyer, 608 E. Main St., Roaring Spring, Penn.
Carl Price, 844 West Adams St., Chicago, Ill.
C. L. Fontana, 621 - 17th St., S.E., Cedar Rapids, Iowa.

H. S. Heineman, 3512 No. 7th St., Philadelphia, Pa.
Nathan Shor, 2922 Violet Ave., Baltimore, Md.
B. L. Sales Service, 2423 N. 44th St., Milwaukee, Wisc. (Dealers.)

STRICTLY BUSINESS

Fada Radio & Electric Corp., 16 Orchard St., Long Island City, N. Y., has made an assignment to Thomas C. Walsh, 40 Worth St., New York City.

Lee De Forest, the General Talking Pictures Corp., and the De Forest Phonofilms, Inc., are losers in a patent suit brought by the American Tri-Ergon Corporation of Switzerland, and Joseph Engle, Joseph Massolle and Hans Vogt, of Berlin. The plaintiffs were sued for damages in connection with the rights in a glow lamp used for photographic recording of sound. The Commissioner of Patents had previously refused the application for patents to the foreign claimants in favor of De Forest and his associates.

VITAL VOLUME!

John F. Rider's
Vol. IV

Perpetual Trouble Shooter

SERVICING during 1934 will be more complicated than at any time during the past 14 years of radio activity. Volume IV is your means of combating the numerous highly scientific problems of design introduced by the receivers sold during 1933.

"I do not hesitate to say that Volume IV is the most important of all the manuals I have issued. Volumes I, II and III found their place in the servicing world as important aids to the service man . . .

"Volume IV is destined to be more than just an important aid. . . . It will be a vital necessity. . . . I am firm in the belief that because the contents of Volume IV cover the most scientific and complicated radio receivers ever produced in the history of the radio industry—its ownership will mean the difference between success and failure when servicing the 1933 crop of radio receivers.

"You will witness a new era in radio servicing during 1934 . . . and it is only the start of complex radio service problems. . . . Research laboratories in contact with receiver manufacturers forecast increased science applied to radio receiver design. . . . We are passing out of the three and four tube receiver stage—back into the 8, 10 and 12 tube stage with highly complicated electrical networks. . . . Hourly use of radio service data will be imperative. . . ."

John F. Rider.
Volume IV has in it 1040 pages in the loose leaf binder; about 20 pages in a separate supplement and the index, covering all of the manuals, totals about 40 pages, making a grand total of approximately 1100 pages.

The binder used in Volume IV is identical to that employed for Volume III. It is loose leaf employing the finest of materials. Aligner bar "instant removal" mechanism is employed.

Volume IV, Price \$7.50, postpaid

Also:

Volume I, Rider's Perpetual Trouble Shooters Manual	\$7.50
Volume II—Does not duplicate Vol. I	6.50
Volume III	7.50
Rider's Combination "3 in 1" Manual, now ready (Vols. I, II and III)	21.50
Rider's Combination "3 in 1" Manual, with carrying handles	25.00

Address: BOOK DEPT.

RADIO WORLD

145 W. 45th St., New York, N. Y.

"MODERN STORAGE BATTERY PRACTICE," by A. D. Althouse and Carl H. Turnquist, of Cass Technical High School, Detroit. A new and practical handbook prepared for the beginner and experienced battery man alike, and includes methods, materials, equipment, tables and special data, also index for quick references. 277 pages, 258 illustrations, flexible binding. Price \$2.50. RADIO WORLD, 145 W. 45th St., New York City.

"RADIO AND TELEVISION," by James R. Cameron. Over 540 pages, 275 illustrations; cloth bound. The subject of radio and television covered in such a manner that it is easily understood even by a beginner. Price \$4.00. RADIO WORLD, 145 West 45th St., New York City.

Station Sparks

By Alice Remsen

CHECKING OFF THE CLOCK

THE MAJOR RADIO NETWORKS have decided to concentrate on daytime programs, so Mr. and Mrs. Daytime Listener will not have to wait until night-fall to hear some of their favorites. It has been discovered that the earlier programs pull just as much mail as the later ones. NBC has been doing this for quite a while and getting good results. Columbia has just fallen into line. This is good news for radio artists! . . . Lawrence Tibbett, famous American baritone, will be starred in a new triple role on a weekly series of broadcasts over an NBC-WJZ network, starting September 18th. The famous singing actor will be presented by the Packard Motor Company of Detroit every Tuesday at 8:30 p.m. John B. Kennedy, popular radio commentator, will be master of ceremonies. This new three-fold role will bring to radio for the first time the gamut of Tibbett's unusual ability, and will show him as a singer, actor and man. He will enact famous roles from opera and screen, will take part in dramatizations based upon his own life; and—as a personality—a man rather than an artist—he will discuss general topics with Kennedy, tell anecdotes about himself and celebrities he has known, and comment on music and musicians. . . .

THE QUEEN SPEAKETH

The Queen of Holland will be heard in America on an international hook-up, at the opening of the Dutch Parliament in the Hague on September 18th, over an NBC-WEAF network at 9:20 a.m., weather permitting. . . . The Fresh Air TaxiCab Company has been discarded for good, and a new business created for Amos n' Andy. The boys return to the air-waves on September 17th. What the business will be nobody seems to know, but I, for one, will be listening! . . . "One Man's Family," a dramatic series originating in the NBC San Francisco studios, is to be presented the Radio Stars Award for Distinguished Service to Radio! . . . Tony Wons has deserted his old stamping ground and gone over to NBC; he and his Scrapbook may now be heard mornings over WJZ at 11:15, Monday, Tuesday, Wednesday and Saturday. The broadcast will originate in the NBC Chicago studios. Wons will also be heard on a sponsored program each Sunday afternoon at 5:30 p.m. over WEAF.

THE BEST VALUE . . . IN A RADIO BOOK

"Servicing Superheterodynes"

New Revised, Enlarged Edition (August, 1934)

BY JOHN F. RIDER

Price, \$1.00 Postpaid

This volume, generously illustrated, consists of 292 pages (about 1/3 cent per page) into which Rider has put his extensive knowledge of superheterodyne servicing. The contents include:

- Introduction: Difference between T.R.F. and Super.
Chapter I: Principles of Superheterodyne Operation.
Chapter II: Generation of and Relation Between Harmonics.
Chapter III: Different Types of Supers Explained.
Chapter IV: Functions of Individual Parts of Super.
Chapter V: Special Circuits and Tube Applications.
Chapter VI: Troubles, Symptoms, Remedies.
Chapter VII: Test Oscillators.
Chapter VIII: Vibrator Units.

The appendix lists i.f. of all commercial receivers.

RADIO WORLD

145 West 45th Street New York City

. . . John Rogers and Aileen Vance are a new harmony singing team from Alabama. They left their home in the South only a few weeks ago to try their luck in the big city, and now they may be heard every Wednesday morning on an NBC-WEAF network, singing for the Empire Gold Company, at 11:15 a.m.

FLOYD GIBBONS ON HIS OWN

Floyd Gibbons, now pinch-hitting for Phil Baker, will open on a new series of his own, sponsored by the Johns-Manville Corporation, beginning September 15th and every Saturday thereafter at 7:45 p.m. over an NBC-WEAF network. . . . Frank Pinero, veteran NBC violinist, has been chosen to conduct the orchestra for the Red Davis series when those sketches return to the air on October 1st. . . . The Hoover Sentinels are no more a new name, time and style of program are now being used by this pioneer broadcaster. The program is now called "The Sentinels Serenade." . . . Jessica Valentina Dragonette is the full name of the Cities Service star. Her middle name, never used professionally, was bestowed because she was born on St. Valentine's Day in far-off Calcutta, India. . . . Followers of Edgar Guest will have to dial the Hoosier poet earlier after September 18th. The old time of nine o'clock has been changed to 7:30 p.m., each Tuesday over an NBC-WJZ network, under the sponsorship of the Household Finance Corporation. . . . One of the oddest of hobbies is collecting old beer bottles; Joe Cook does it! . . . Harold Levy, who conducts several sustaining programs and the Mohawk Treasure Chest orchestra over NBC, played with Sousa's Band when he was only fourteen. . . . September 10th was the date set for the return to the air of "The Voice of Experience"—six programs a week, at 12 noon Mondays through to Fridays, and 6:45 p.m. Sundays, over the WABC-Columbia network, sponsored by the Wasey Products, Inc. . . .

HAZEL REPLACES MURIEL

Hazel Glenn, soprano, joins the cast of "Lavender and Old Lace" as a featured soloist with the broadcast of Sept. 11th, at 8:00 p.m. over WABC and network. Miss Glenn replaces Muriel Wilson as co-star with Frank Munn. . . . Leith Stevens, the young orchestra director, arranger and conductor of male choruses for the Columbia Broadcasting System, is only twenty-five years old. He is the husband of Mary McCoy, well-known soprano, and was born in Mt. Moriah, Missouri. He is tall, blonde and amber-eyed; raises Scotties, plays polo and owns his own ponies. He was born on Friday the 13th. Went to school with Ramona, Thelma Kessler, Evan Evans, Charles Carlile and Raymond Middleton among others. Take it from me, he's a fine chap! . . . Frank Crumit says—in Columbia's "Quotes of the week";—"Some day a school to teach radio script

SHORT-WAVE AND PUBLIC ADDRESS MANUAL

FREE

192 pages, 400 illustrations, costing \$4,000 to produce. And yet a copy of this manual will be sent to you free if you send \$1.00 for an 8-week subscription for RADIO WORLD. Existing subscribers may extend their subscriptions under this offer.

Bound in cardinal red leatherette, this manual includes articles on the construction of short-wave receivers from one to nine tubes, inclusive, and all values between, supers and t-r-f, with the clearest imaginable illustrations, both photographic and draughting. Besides the usual plain circuit diagram there is a pictorial diagram showing and informative. Portable short-wave sets, design and winding of coils for short waves and broadcasts (intimately illustrated), list of short-wave stations with meters and kilocycles and hours on the air; trouble-shooting, and forty other topics, all done well.

The public address section contains data on different systems, how to use them, and offers opportunities to turn public address work to profit. Besides, there are articles on testing and servicing not encompassed by the title of the manual—signal generators, broadcast home and portable sets, analyzers, formulas, capacity data. Everything plainly told, simple language, from microphones to speakers.

Send \$1.00 now and get RADIO WORLD for 8 weeks and the manual free. Ask for Cat. PR-SPAM.
RADIO WORLD, 145 W. 45th St., New York, N. Y.

A THOUGHT FOR THE WEEK

BROADWAY and Times Square and even Radio City will miss Charles B. Dillingham, who, after a lifetime of giving fine entertainment to the public, passed away. He left no money but he left what money cannot buy, a pleasant memory for those who knew him even slightly and affectionate heart throbs among those who knew him long and well.

Charlie Dillingham was a newspaper man, an editor, a manager and a producer, but chief of all he was a normal-minded man not afraid to declare that the cleanest things in entertainment were none too clean for his public. His smile was worth going blocks out of one's way to see. It was not carelessly thrown about to anybody on the side lines, but was free to all who would look for it, but warmest and fullest and most meaningful for his closest friends.

Surely for him these lines were written: "There is no duty so much under estimated as the duty of being happy. By being happy we shower anonymous benefits upon the world and which remain unknown even to ourselves. A happy man or woman is a better thing to find than a five-pound note. He or she is a radiating focus of good will and their entrance into a room is as though another candle had been lighted." Charlie Dillingham must have been known to Robert Louis Stevenson, the man who wrote those words.—R. B. H.

writing will be established, just as schools of journalism were organized to equip writers for the special field of newspaper writing."—Let's hope so, Frank; some of the scripts used over the air could do with a bit of looking-over by a competent teacher. . . .

Carlyle Stevens, Columbia announcer, is the father of a new bouncing boy. Congrats! . . . Georgie Price's father was a barber; he has a sister named Lillian, a wife named Lorain and a daughter named Georgian. . . . Georgie Burns and Gracie Allen are back from their trip to Europe. While away they played an engagement at the London Palladium. Their broadcasts for the White Owl Cigar Company start on September 19th. . . . Lazy Bill Huggins has joined the Enoch Light Orchestra and will be heard with that musical aggregation three times weekly over CBS from the Claremont Inn. . . . Rumor says that Everett Marshall will make a movie soon—and why not? . . .

It seems to me that the American Broadcasting System is doing pretty well for itself in the short time it has been organized. . . . All weekly luncheon meetings of the Advertising Club of New York will be broadcast each Thursday at 1:15 p.m. over the ABS-WMCA network.

New Tack Being Tried to Win Public's Favor

A few years ago semi-automatic tuning was tried by some manufacturers, but it did not prove popular. It seemed to be one of those inventions the necessity for which was felt more by the inventor than by anybody else. It consisted of a device whereby levers were set for particular stations, so that to tune in the desired station the lever was pulled, instead of the dial being turned. Tweedle-dee and tweedle-dum. And the depression was just in its infancy.

Now another system is being tried, and one manufacturer has a clock mechanism and motor combination, so that the receiver may be present to bring in programs at the desired time. All one need do is to plug in the different tips and the day's programs are selected in advance, the set automatically turning itself on and off, as directed by these preparations. That is quite a different matter and might catch on, as a service actually is rendered.

Quick-Action Classified Advertisements

7c. per word. \$1.00 minimum.

WE MAKE TO YOUR SPECIFICATIONS; chassis, shields, panels, test equipment. Chassis 10" x 12" x 3", \$3.00. Constructors Supply, 303 Furman St., Schenectady, N. Y.

FLASH SOLDERING IRON—Instantaneous soldering Weld. Burn all light metals. Uses current only when in Contact. Operates on battery or Deico. \$1.50. Casa Leon, 1401 West Grand Boulevard, Detroit, Michigan.

HAMS! Kit of all parts for National SW3; eight coils. First \$10.00 takes it. J. W. Cullen, 249 Chadron Ave., Chadron, Nebraska.

UP TO \$50.00 PAID FOR INDIAN HEAD CENTS; Half Cents, \$250.00; Large Cents, \$2,000.00, etc. Send Dime for list. ROMANO-COINSHOP, Dept. 304, Springfield, Mass.

SELL BY RADIO. Big profits. New Plan. Start Now. Complete Instructions, \$1.00. Nothing Free. Manning's Dept. B, 1229 Park Row Bldg., New York City.

HANDY MEN—Establish much-needed Vacuum Cleaner Repair Service. Very profitable. Write E. G. Brown, 610 Atlantic Ave., Boston, Mass.

LOST KEYS are returned to you promptly when you use our service. Full Ten Year Service for \$5.20. Only one cent a week. Send your order today. Velva Service Bureau, Dept. B, Box 546, Lima, Ohio.

PORTRAITS COLORED, 25c dull prints only. Leon C. Roffe, Laurens, N. Y.

NEW RADIO AMATEURS HANDBOOK, 180,000 words. 207 illustrations, 218 pages (10th edition, issued 1933). Issued by the American Radio Relay League. Price, \$1.00 per copy. Radio World, 145 West 45th Street, New York, N. Y.

"MODERN ELECTRIC AND GAS REFRIGERATION," by A. D. Althouse and C. H. Turnquist. A timely book of practical and usable information on installation, service, repair of all types of automatic refrigerators. 275 pages, 175 illustrations, diagrams in six and eight colors. Price \$4.00. RADIO WORLD, 145 W. 45th St., New York City

RADIO WORLD AND RADIO NEWS. Both for one year, \$7.00. Foreign \$8.50. Radio World, 145 W. 45th St., N. Y. City.

JOB'S TEARS

Nature's Curiosity—Petrified pearly seeds from Tropic Jungles make necklaces, bracelets, rosaries and novelties. 20c hundred; \$1.00 thousand.

H. KLEIN, 1710 West Second Street Brooklyn, N. Y.

Subscribers! Important!

Note subscription expiration date on wrapper containing your copy of RADIO WORLD. If nearing expiration date please send in renewal so that you will not miss any copies. Subscription Dept., RADIO WORLD, 145 W. 45th St., New York City.



For A-C and D-C Operation

Will work anywhere that 110 volt A-C or D-C is available. U. S. amateur reception is assured on loudspeaker by the use of a 43 power tube in the output.

With headphones the entire world is at your finger-tips. Chassis is completely encased in a beautiful crystal finished cabinet. Covers the short wave, band from 15-200 meters. Uses one 78, one 25Z5 and one 43 tube.

Price Kit.....\$8.95

Wired.....\$2.00 extra. Tubes.....\$3.25

Direct Radio Co., 145 W. 45th St., N. Y. C.

DUAL-BAND TUNING UNIT

FOR broadcast reception, plus coverage to higher than 4,000 kc, thus yielding a total span of 540 to higher than 4,000 kc. We have an exceptionally precise combination, consisting of three r-f coils, one of which is used as antenna coupler, and one oscillator coil, also the necessary four-gang condenser and the correct padding condenser (Hammarlund adjustable type). The tuning coils for the r-f level have secondaries tapped so that the condenser stator may be switched from full inductance to just enough inductance to pick up the broadcast band where the full inductance left off. The oscillator coil is appropriately tapped, also, for this purpose. A four-pole, double-throw switch would be required (not furnished). Coils aluminum shielded, 2-1/16" outside shield diameter by 2.5 inches high. The four-gang condenser is very compact (5 x 2.25 x 2.75 inches). All material is specially made for this premium order and is of highest calibre.

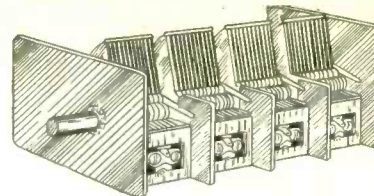
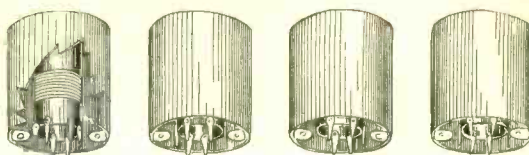

Same as above, same terms, except oscillator is for 175 kc and Padder is 850-1350 mmfd. Order PR-BCTU-175.

TUNING UNIT FOR TEST OSCILLATOR

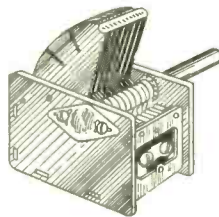

HERE is your very first opportunity to get the parts for constructing a universal, modulated test oscillator to cover fundamentals from 135 to 380 kc, and read higher intermediate frequencies and the entire broadcast band, by harmonics, all imprinted right on the dial. That is, the oscillator will be direct frequency-reading. The parts consist of one metal-etched scale, one metal escutcheon, one 0.000406 tuning condenser with trimmer built in, one oscillation transformer (secondary inductance accurate to 0.1 per cent.), and one knob for condenser. Circuit diagram supplied for universal model modulated test oscillator (90-120 volts a.c., d.c. or batteries, same oscillator works on all three). Instruction sheet for lining up at broadcast and intermediate frequencies included. Line up the oscillator with one adjustment on broadcast band, beating with some station on 1,200 to 1,400 kc. Whole dial then will track. Order PRE-TUTO and send \$6.00 for one-year subscription for (52 issues). Sent postage prepaid.

MICA-DIELECTRIC Intermediate Transformers

For 465 kc or 175 kc i.f. we offer doubly-tuned transformers, with mica-dielectric condensers built in, all enclosed in 4-inch high aluminum shield, 2-1/16-inch diameter. Quantity is at left. Sent postpaid.

Single Transformer

- (1) PRE-MD-465... \$2.00 subscription. 16 issues
- (1) PRE-MD-175... \$4.00 subscription. 34 issues
- (2) PRE-MDD-465... \$6.00 subscription. 52 issues
- (2) PRE-MDD-175... \$12.00 subscription. 104 issues
- (3) PRE-MDDD-465... \$18.00 subscription. 156 issues
- (3) PRE-MDDD-175... \$36.00 subscription. 312 issues

Complete Selection of Tubes



The following highest-grade, licensed, brand-new, 10-day-replacement-guarantee tubes are offered as premiums.

One Tube for \$1.00 Subscription, 8 Issues. 01A, 01AA, 1V, 12Z3, 112A, 24A, 26, 27, 30, 31, 35, 36, 37, 38, 39, 45, 47, 51, 56, 71A, 80, 82.

Any two of above tubes for \$2.00 Subscription (16 issues), any three for \$3.00 Subscription (26 issues), any six for one-year Subscription (52 issues).

AIR-DIELECTRIC Intermediate Transformers

For unequalled maintenance of the frequency to which the intermediate channel is adjusted, air-dielectric tuning condensers must be provided. These are supplied on Isolantite forms, and are made by one of America's premier precision radio parts manufacturers. Quantity at left.

- (1) PRE-AD-465... \$6.00 subscription. 52 issues
- (1) PRE-AD-175... \$12.00 subscription. 104 issues
- (2) PRE-ADD-465... \$18.00 subscription. 156 issues
- (2) PRE-ADD-175... \$36.00 subscription. 312 issues
- (3) PRE-ADDD-465... \$54.00 subscription. 468 issues
- (3) PRE-ADDD-175... \$108.00 subscription. 936 issues

One Tube for \$1.50 Subscription, 13 Issues.

1A6, 5Z3, 2A5, 2A6, 2A7, 2B7, 6A4, 6A7, 6B7, 6F7, 25Z5, 22, 32, 33, 34, 41, 42, 44, 46, 49, 53, 55, 57, 58, 59, 67, 75, 77, 78, 83, 83V, 84, (6Z4), 85, 89, 483, 485. Any two of the \$1.50 group for \$3.00 Subscription (26 issues), any four for \$6.00 Subscription (52 issues).

TUBES SENT POSTAGE COLLECT.

VITAL BOOK

The biggest help any one can get who desires to wind radio-frequency coils for any frequency from just below the audio range to the fringe of ultra frequencies is to have a book that tells just what inductance is required for the condenser one possesses, and just how many turns of any kind of wire on any sensible diameter are needed to produce that inductance. "The Inductance Authority," by Edward M. Shlepe, gives you just that information, to an accuracy of 0.1 per cent. Send \$4.00 for an eight-months subscription (39 issues) and order PRE-IA sent postpaid.

POWER TRANSFORMER

Primary—105-130 volts. Secondary A-2.5 volts, center-tapped. Secondary B-110 volts, no center tap.

Splendid for powering a-c test oscillator or any other rectifier for not more than three small tubes.

Order PRE-SPTR and send \$1.50 for three-month subscription (13 weeks) postpaid.

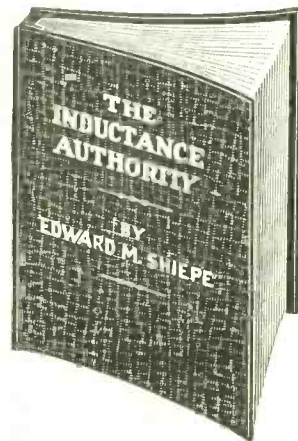

Small Power Transformer

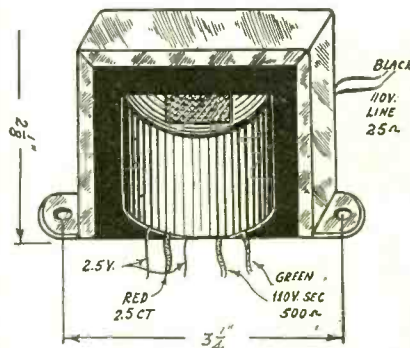

RADIO WORLD, 145 WEST 45th STREET, NEW YORK, N. Y.

"DYKE'S AUTOMOBILE AND GASOLINE ENGINE ENCYCLOPEDIA," by A. L. Dyke. New 16th Edition, covering all the latest developments. A complete training in every part of automotive work, and for easy study is divided into a series of 85 simple instructions, 1,339 pages, 4,40 illustrations and diagrams. 6 1/2 x 9 1/4. Includes chapters on Free Wheeling and Radio Receiving Equipment for Autos. Cloth, \$6.00. Flexible, \$7.50. Radio World, 145 W. 45th St., New York City.

"SWOOP'S LESSONS IN PRACTICAL ELECTRICITY," 17th Edition, Revised by Erich Hausmann, E.E., Sc.D. Requires no previous technical knowledge; fully explains every question about the entire subject of electricity. New chapters on vacuum tubes, telegraphy, telephony and radio signalling. 709 pages, 542 illustrations, 5 1/2 x 8, Cloth, \$2.50. Radio World, 145 W. 45th St., New York, N. Y.

Great

for Every Short-Wave Fan and General Radio Man



GREEN EXCHANGE BUILDING

News!

We Announce the Opening of Our New Modern Offices

MODERN DISPLAY ROOMS
DEMONSTRATIONS DAILY

AT 130 CEDAR STREET
NEW YORK CITY

PROMPT RADIO SERVICE COMPANY



"ROCKET"

TWO TUBE
Battery-Operated
SHORT-WAVE
RECEIVER
15 TO 200 METERS

Uses 2-230 type two-volt tubes for perfect and quiet reception. Contains every part for construction.
"Rocket" Two kit of parts, including blue print **\$4.50**
"Rocket" Two complete with coils, wired and tested **\$5.50**
Set of Sylvania tubes **\$1.40**
Complete set of batteries for "Rocket" Two (2-45 v. and 2-1½ v. dry cells) **2.25**
Broadcast coil (200 to 550 meters) **.49**

Handy Two Tube Battery Operated

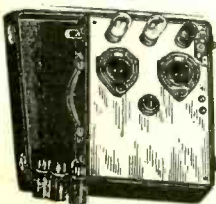

PORTABLE Short Wave Receiver

The set chassis and batteries are all contained in the beautiful leatherette covered carrying case. Complete kit of parts, including four plug-in coils, carrying case, panel, and blueprints, less tubes and batteries. Sale price,

\$10.95

Wired and tested, extra.... \$2.00
Complete set of batteries and tubes for the Powertone Tube Portable. Sale price..... 3.25

DUO-AMPLDYNE

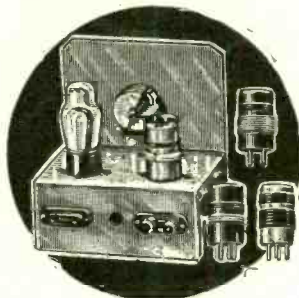

S.W. RECEIVER

For the Short-Wave enthusiast with a limited finance. Radically new—two-tube results with the new '19 2-volt series tube. Covers from 15 to 550 meters.

Complete kit of parts..... **\$4.95**
Wired (extra) **1.00**
Licensed tube **.83**
Set of headphones..... **.95**
Broadcast coil (200-550 meters) **.39**

"COSMAN TWO"

15 TO 550 METERS
Battery-Operated
SHORT WAVE
RECEIVER

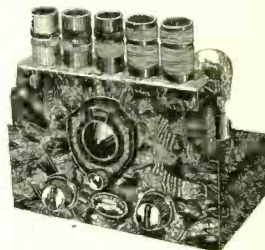

Its unusual design permits reception on a LOUD-SPEAKER. Incorporates a 232 and a 233 output pentode. Kit of parts with 4 Bruno coils **\$5.95**
Wired and tested, extra. \$1.00
Set of R.C.A. licensed tubes **1.95**
Broadcast coil **.39**

BEGINNERS TWIN

Two Tube "Battery"—15 to 200 Meters
SHORT-WAVE RECEIVER

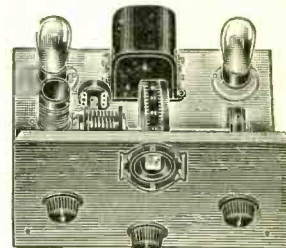

The "Beginner's Twin" is probably the best kind of introductory set for the beginner, who can readily make changes and improvements on it as he becomes more familiar with short-wave technique.

Complete kit of parts for the "Beginner's Twin" with drilled panel and base, coils, blue print, less tubes **\$7.95**
"Beginner's Twin." Completely wired and tested extra **\$2.00**
Set of 230 R. C. A. Licensed Tubes **\$1.40**
Set of Batteries (2-45 volt "B"; 2 No. 6 dry cells)..... **\$1.95**

PROMPT RADIO SERVICE CO., 130 CEDAR STREET, NEW YORK CITY.

WE DO NOT PRINT A CATALOG. ORDER FROM THIS PAGE. You are cordially invited to visit our showrooms and inspect these S.W. Receivers

BUD POLICE THRILLER and SHORT WAVE ADAPTER

Get Police Calls

On Your Present Radio With

BUD POLICE THRILLER

Fits Any Electric Radio—Easy to Install
Entertaining and Inexpensive

No. 2427—BUD POLICE THRILLER has a self-contained Regeneration Control. This model can be used on sets using screen grid or 27 for Detector Tube.

Price \$2.15

RELIABLE RADIO CO.
143 W. 45th Street, New York

Wind Your Own Short-Wave Coils

Using data published in May 19th issue of Radio World.

1½-inch diameter ribbed Bruno forms, bakelite moulded, set of four, vari-colored, four-pin bases **\$1.10**
Same as above, but six-pin base (four forms) **\$1.20**
Set of four Bruno two-winding, vari-colored forms **\$2.50**
Set of four Brunos, three-winding **\$3.00**
Insuline two-winding coils (four) **\$2.00**
Insuline three-winding coils (four) **\$2.40**

SCREEN GRID COIL CO.

145 West 45th Street New York, N. Y.

The World Is Yours!

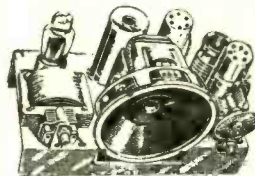

Four-Tube
A-C
Short-Wave
Receiver
with Built-In Speaker

Will tune in short wave stations from all parts of the world with ease. Uses four plug-in coils to cover the entire short-wave band from 15 to 200 meters. The built-in power supply is entirely free from hum or disturbing line noises. Uses an ultra-sensitive dynamic speaker which aids in tuning in the weaker signals.

Cat. 4TK. Kit of Parts, less cabinet, less tubes..... **\$17.50**
Cat. 4TW. Above, completely wired and tested **\$19.50**
Cat. 4TCB. Cabinet only... **\$1.50** extra
Cat. 4TTU. Complete set of licensed tubes..... **\$2.50** extra

Reliable Radio Company

145 West 45th Street
NEW YORK CITY

SELLING OUT \$1.75

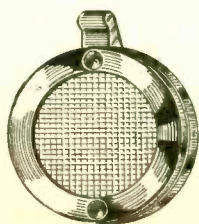

A single button carbon-granule lapel microphone, impedance 200 ohms, requiring 4.5-volt excitation, of good frequency characteristics, and both handy and inconspicuous. Outside diameter, 1½ inches. The case is chromium-plated brass. The excitation may be provided by introducing the microphone in a cathode circuit carrying around 20 to 25 milliamperes or a 4.5-volt C biasing battery may be used. Net price, \$1.75.

RELIABLE RADIO COMPANY
145 West 45th Street, New York, N. Y.

A COMBINATION OFFER!

RADIO WORLD
and "RADIO NEWS"

\$7.00

Canadian and Foreign, \$1.50 extra.

You can obtain the two leading radio technical magazines that cater to experimenters, service men and students, the first national radio weekly and the leading monthly for one year each, at a saving of \$1.50. The regular mail subscription rate for Radio World for one year (52 weeks), RADIO WORLD, 145 West 45th Street, New York, N. Y. is \$6.00. Send in \$1.00 extra, get "Radio News" also for a year—a new issue each month for twelve months. Total 64 issues for \$7.00.

RADIO WORLD, 145 West 45th St., N. Y. C.