

DEC. 12
1931

6-TUBE ALL-WAVE T-R-F

PRICE
15c
Per Copy

RADIO

REG. U.S. PAT. OFF.

WORLD

The First and Only National Radio Weekly
508th Consecutive Issue

TENTH YEAR

*What to Do
When Stumped
on Coil
Problems*

ANTENNA CURRENT LIGHTS LAMP



(Acme)

Although just an ordinary electric lamp, with a 6-foot aerial, this lamp lights merely by reason of its presence in an ultra high frequency field in the power tube laboratory of the Westinghouse Electric and Manufacturing Company, at Schenectady, N. Y. The field is produced by a standing wave oscillator which sends out from the antenna overhead 15,000 watts of power on three meters. This power lights lamps within 40 feet and cooks food in seconds. H. V. Noble, Research Engineer, tries to explain the phenomena quickly to Evelyn Tray (left) and Vera Goga, because after a few minutes their bodies could get warm.

**OSCILLATOR
FREQUENCIES
STABILIZED**

*Vertical
Aerial for
Short Waves*

**8 TUBE
BAND PASS
SUPER**



R.C.A. Victor Microphone
RECORDING AND HIGH GAIN
SPEECH MICROPHONE
A SINGLE BUTTON "MIKE"
which is used with the latest model
Radiola 86 Home Recording Super-Hetero-
dyne Receiver and Amplifier. 6 1/2" high
and is supplied with a four foot cord.
Your Price\$2.75

Try-Mo Radio, Inc.
177 Greenwich St. New York City
SEND FOR CATALOGUE

These Prices Will Interest You!

SPEAKERS

Farrand inductor dynamic for pentode tubes, chassis (no cabinet), for direct connection in plate circuit of single output tube, or for connection to secondary of an output transformer where push-pull pentodes are used. 9 inch outside diameter. Order Cat. 9-R.....@ \$7.00

Farrand regular dynamic, chassis (no cabinet), with built-in rectifier, for AC operations. 9 inch outside diameter. Order Cat. F-DNS.....@ \$7.00

Erla regular dynamic, chassis (no cabinet), for 6-volt storage battery operation, Westinghouse rectifier. Order Cat. ER-DYN.....@ \$8.50

Ansonia magnetic speaker, in square cabinet, genuine walnut. Order Cat. AN-SQ.....@ \$3.00

Temple dynamic speaker, in carved wood cabinet, with impedance matching device built in; AC operation; rectifier built in. Order Cat. TEM-DYN.....@ \$10.23

BOOKS

Official Radio Service Manual, by Gernsback & Fitch@ \$2.10

Supplement No. 1 to Rider's Manual. (115 diagrams.) Cat. R-SUP.....@ \$.60

COILS

Three-circuit tuner coil for .0005 mfd., with silver-plated wire and space-wound winding on threaded bakelite form. Cat. SPW-T.....@ \$1.10

Radio frequency coil to match above, same construction. Cat. SPW-RF.....@ .65

RESISTORS

25,000 ohm potentiometer. Cat. POT-25....@ \$.85

Adjustable voltage divider, with sliders; six different voltages besides extremes; total is 10,000 ohms. Order Cat. VVD.....@ 1.00

Fixed voltage divider, total 17,100 ohms, affording twenty different voltages, including all bias voltages; for 245, 247 and similar circuits; 50 watts rating. Order Cat. MIVD.....@ 1.95

Carborundum grid leaks, 5 meg. Cat. CAR-5.....@ .10

30 ohm filament resistor, 1 ampere capacity. Cat. FR-30.....@ .10

6.5 ohm filament resistor, 1 ampere capacity. Cat. FR-65.....@ .10

2250 ohm 25 watt resistor (Ward Leonard). Cat. WL-2.....@ .10

30 ohm variable center tap Humdinger. Cat. HMD.....@ .39

RELIABLE RADIO COMPANY
143 West 45th Street
New York, N. Y.



Latest Midget Hand Type Mike can be worn on lapel.
No. 306. List \$5.00.
Used for public address work as Callophone System when attached to your radio.

MILES REPRODUCER CO.
28 E. 22nd St., New York

1,000 PAGES! 2,000 DIAGRAMS! IN RIDER'S NEW 7-POUND MANUAL

JOHN F. RIDER'S PERPETUAL TROUBLE SHOOTER'S MANUAL is the book you need if you want to do profitable servicing. This loose leaf volume contains every bit of radio service information of all popular commercial broadcast receivers manufactured since 1920 and includes the latest diagrams. In addition to the wiring diagrams of the receivers the Manual contains chassis layouts, color coding, electrical values, chassis wiring diagrams, and the wiring of units sealed in cans. It also contains a course in Trouble Shooting, the use of set analyzers, data upon Superheterodynes, automatic volume control, etc. Page size is 8 1/2 x 11, bound, 1,000 pages, index and advertisements on additional pages. Order CAT. RM-31 and remit \$4.50. We will then pay postage. Shipping weight 8 pounds. Ten day money back guarantee.

RADIO WORLD
145 WEST 45th ST. NEW YORK CITY

METALLIZED RESISTORS

PLAIN ENDS

1.0 meg. and 2.0 meg.

PIGTAIL ENDS

.52 meg. (20,000 ohms) .5 meg. (500,000 ohms)
.95 meg. (50,000 ohms) 0.1 meg. (100,000 ohms)
2.0 meg. and 5.0 meg.

Price, 25c each, all sizes as above.

Mounting for plain end leaks, Lynch moulded product, 15c.

DIRECT RADIO CO.

143 West 45th St., New York, N. Y.

"RADIO TROUBLE SHOOTING," E. R. Haan. 328 pages, 300 illustrations, \$3. Guaranty Radio Goods Co., 143 W. 45th St., New York.

FOR THAT BOY—OR MAN—AT CHRISTMAS TIME!

Why not have us send him RADIO WORLD for the coming year so that he can keep abreast of all that is going on in radio? Besides, every week RADIO WORLD will carry him a message that suggests your thoughtfulness.

Also, on receipt of your \$6, we shall take pleasure, if you wish, in sending him a special letter to the effect that you have requested us to put his name on our subscription list for 52 issues, as a holiday gift.

Subscription Dept., RADIO WORLD, 145 West 45th St., New York City

Two for the price of One

Get a FREE one-year subscription for any ONE of these magazines:

- RADIO CALL BOOK MAGAZINE AND TECHNICAL REVIEW (monthly, 12 issues)
- POPULAR MECHANICS AND SCIENCE AND INVENTION (combined) (monthly, 12 issues).
- POPULAR SCIENCE MONTHLY
- RADIO INDEX (monthly, 12 issues), stations, programs, etc.
- RADIO (monthly, 12 issues; exclusively trade magazine).
- MODERN RADIO (monthly).
- EVERYDAY SCIENCE AND MECHANICS (monthly).
- RADIO LOG AND LORE. Monthly. Full station lists, cross indexed, etc.
- AMERICAN BOY—YOUTH'S COMPANION (monthly, 12 issues; popular magazine).
- BOYS' LIFE (monthly, 12 issues; popular magazine).

Select any one of these magazines and get it FREE for an entire year by sending in a year's subscription for RADIO WORLD at the regular price, \$6.00. Cash in now on this opportunity to get RADIO WORLD WEEKLY, 52 weeks at the standard price for such subscription, plus a full year's subscription for any ONE of the other enumerated magazines FREE! Put a cross in the square next to the magazine of your choice, in the above list, fill out the coupon below, and mail \$6 check, money order or stamps to RADIO WORLD, 145 West 45th Street, New York, N. Y. (Add \$2.00, making \$8.00 in all, for extra foreign or Canadian postage for both publications).

Your Name.....

Your Street Address

City.....State.....

- If renewing an existing or expiring subscription for RADIO WORLD, please put a cross in square at beginning of this sentence.
- If renewing an existing or expiring subscription for other magazine, please put a cross in square at the beginning of this sentence.

RADIO WORLD, 145 West 45th Street, New York. (Just East of Broadway)

DOUBLE VALUE!

BLUEPRINTS

627. Five-tube tuned radio frequency, A-C operated; covers 200 to 550 meters (broadcast band), with optional additional coverage from 80 to 204 meters, for police calls, television, airplane, amateurs, etc. Variable mu and pentode tubes. Order BP-627 @25¢
- 628-B. Six-tube short-wave set, A-C operated; 15 to 200 meters; no plug-in coils. Intermediate frequency, 1,600 kc. Variable mu and pentode tubes. Order BP-628-B @25¢
629. Six-tube auto set, using automotive tubes, with pentode push-pull output. Order BP-629 @25¢

RADIO WORLD

145 WEST 45TH ST., NEW YORK, N. Y.

Large Temple Dynamic

Dynamic speaker, AC 110 Volts, 50 to 60 cycles, housed in table cabinet made of walnut, with carved grille. Output transformer and dry rectifier built in, also a hum eliminating adjuster and a variable impedance matcher. Plugged AC cable and tipped speaker cords are attached to dynamic. Outside cabinet dimensions: Height 14", width 11, depth 7 1/2". Speaker diameter 9". Price, \$11.50 net.

Guaranty Radio Goods Company
Dept. A, 143 W. 45th St., N. Y. C.

Fixed Condensers

Dublier Micon fixed condensers, type 642, are available at following capacities and prices:

.0001 mfd.	10c	.005	20c
.00025 mfd.	10c	.00025 with slips.	20c
.0005 mfd.	10c	All are guaranteed	
.00055 mfd.	12c	electrically perfect and	
.001	12c	money back if not	
.0015	12c	satisfied within 90	
.002	10c	days.	

GUARANTY RADIO GOODS CO.
143 West 45th St., New York, N. Y.

RADIO WORLD and "RADIO NEWS"

BOTH FOR ONE YEAR **\$7.00** Canadian and Foreign \$8.50

You can obtain the two leading radio technical magazines that cater to experimenters, service men and students, the first and only national radio weekly and the leading monthly for one year each, at a saving of \$1.50. The regular mail subscription rate for Radio World for one year, a new and fascinating copy each week for 52 weeks is \$6.00. Send in \$1.00 extra, get "Radio News" also for a year—a new issue each month for twelve months. Total, 64 issues for \$7.00.

RADIO WORLD, 145 West 45th Street, New York, N. Y.

Receiving Tube Chart

A receiving tube chart, 7 x 13 inches, with accompanying explanatory text, was published in the December 5th issue.

This chart contained the characteristics of 34 receiving and transmitting tubes, and covered all the tubes in general use. The type, purpose, rating, voltage requirements, current, mutual conductance, amplification factor, ohms load and power output were given. The tubes are classified as detectors and amplifiers, power amplifiers, rectifiers, regulators and types for amateur and experimental uses. Data on the new tubes are included. Send 15c for a copy of the December 5th issue and retain this table as a permanent record until the next one is published, which will not be for several months.

RADIO WORLD
145 West 45th Street, New York, N. Y.



Vol. XX No. 14 Whole No. 508
 December 19th, 1931
 [Entered as second-class matter, March, 1922, at the Post Office at New York, N. Y., under act of March, 1879]
 15c per Copy. \$6 per Year

TENTH YEAR
 Technical Accuracy Second to None
 Latest Circuits and News

A weekly Paper Published by Hennessy Radio Publications Corporation, from Publication Office, 145 West 45th Street, New York, N. Y.
 (Just East of Broadway)
 Telephone, BRyant 9-0558 and 9-0559

RADIO WORLD, owned and published by Hennessy Radio Publications Corporation, 145 West 45th Street, New York, N. Y. Roland Burke Hennessy, president and treasurer, 145 West 45th Street, New York, N. Y.; M. B. Hennessy, vice-president, 145 West 45th Street, New York, N. Y.; Herman Bernard, secretary, 145 West 45th Street, New York, N. Y.; Roland Burke Hennessy, editor; Herman Bernard, managing editor; J. E. Anderson, technical editor; J. Murray Barron, Advertising Manager.

Regenerated Audio Used in a Short Wave Receiver

Tapped Coils Effective in R-F Channel—Band Switch

By Clarence G. Ford

GIVEN a simple tuner, such as a stage of tuned radio frequency amplification and a regenerative detector, sufficient sensitivity will be developed for short waves if the audio gain is large enough.

The field strength of signals usually tuned in on broadcast sets, as from locals and semi-distant stations, is great enough to permit one stage of audio, where there are two stages of t-r-f, but with short waves it is different. The signal is weak in strength about the antenna and a powerful audio amplifier is required unless the amplification is greatly increased at radio frequencies, as when the superheterodyne system is used.

However, retaining t-r-f for the tuner, we adhere to one stage of t-r-f, principally because the coil problem otherwise would become complicated, especially as switching is resorted to, rather than use of plug-in coils, and because squealing problems become considerable when there are more than one t-r-f stage. That is not to say that two stages can not be used, for indeed nearly all the television receivers, 80 to 200 meters, have such a system, and they work well. The problem becomes one of importance below 40 meters, but is in itself soluble, only nobody evidently has taken the time to do it commercially, and, as stated, for switch use the problem at low wavelengths becomes more greatly complicated.

Simple Coil System

So the coil system in the present receiver, Fig. 1, is a simple one, consisting of two shielded coils, tapped at two places. The tuning condenser stator is moved from the grid extreme of a coil to one tap and then to another tap, except that the second tap has a series condenser, E, of 100 mmfd., which may consist of a 20-100 mmfd. Hammarlund equalizer set at maximum. If 0.00035 mfd. capacity tuning condenser is used for C1 and C2, then, all capacities considered, the first band of tuning will be from a little above 200 meters to 61 meters, the next band from 62 to 25 meters, and the final one from 26 to 15 meters. The ratio of frequency coverage becomes less as the frequencies increase.

The reason for using a smaller effective capacity from 26 meters down is to avoid too much crowding of the dial and also to increase the ratio of inductance to capacity. The inductance that counts is that part in the tuned circuit. Since the coil is tapped, naturally if the same capacity were used the ratio of inductance to capacity will be continually decreasing, band for band, although within any band it would be going up as higher frequencies were being tuned in, because of less capacity being used. More sensitivity results when the ratio is high, and besides a high ratio is especially desirable in the detector stage for the last band so that regeneration is assured.

Effective Tapped Coil Method

Instead of shorting out turns, or leaving dead ends, practices sometimes resorted to when tapped coils are used, by the present method of stator-sliding, so many of the turns outside the tuned circuit remain as a continuation to grid. In the tuned circuit proper, defined by the tuning capacity and the turns actually across it, the radio frequency resistance should be as low as

practical, which is almost equivalent to restating that the ratio of inductance to capacity should be high, but outside the tuned circuit the series resistance should be as high as practical.

The type of detector was selected for its assistance in developing selectivity, since the two tuned circuits just about get by when a grid leak detector is used, while the negative bias type of detection affords better selectivity, with less sensitivity. However, there are two aspects of the sensitivity situation: one, that the audio has been made bountiful to atone for any diminution of detector output; the other, that since regeneration is used it overcomes any lessened sensitivity in respect to very weak signals.

Many who have used regenerative systems must have noticed that while a strong signal is made stronger by regeneration, a weak signal is built up much more effectively. This is not an experimental assumption but it is theoretically sound. In scientific circles there is no dispute about it whatsoever, and the reason is clear to the engineers by curves exposing the effect of regeneration to be on the basis of the two-thirds power of the grid space.

Bias for the Detector

The 235 tube is used as r-f amplifier, and that improves selectivity, too, compared to the use of a 224 in this position, because of the intentionally poor detecting characteristic of the 235. When a signal swings the grid bias negative, the change in bias does not result in detection of any appreciable order, and so the tube does not bring about crossmodulation or crosstalk, and of course the elimination of both these nuisances is expressible as an improvement in selectivity.

The negative bias for the 224 could be obtained through the voltage drop in a 50,000 ohm (0.05 meg.) resistor in the cathode circuit. Various resistance values, some of them only one-twentieth, are shown from time to time, but the bias may not be very considerably different, because the plate and screen currents are proportionately different, or for very lower screen voltages the bias is less. The detecting point for the 224 is at approximately 5 volts negative for these voltage maxima: plate, 275; screen, 90. The plate voltage is applied through a resistor of 250,000 ohms.

It will be noted that the stated bias is approximately 5 volts negative, and also that the voltages, 275 and 90 volts for plate and screen, are maxima. It is recommended that the plate voltage be kept as near as possible to the maximum, depending on the power transformer, as the greater the applied voltage, the greater the voltage drop in the plate resistor, and the greater the detector output. However, it is also recommended that the plate current be adjusted to 0.1 milliampere, at no signal, and that the screen voltage be from 20 to 45 volts.

Value of Biasing Resistor

Of course, the plate current, hence the effect of the current through the biasing resistor, will be different, depending on the screen voltage. When the detector screen voltage is low the bias should be lower than when the screen voltage is high. The

(Continued on next page)

Three Audio Stages for Stage of T-R-F, Regene

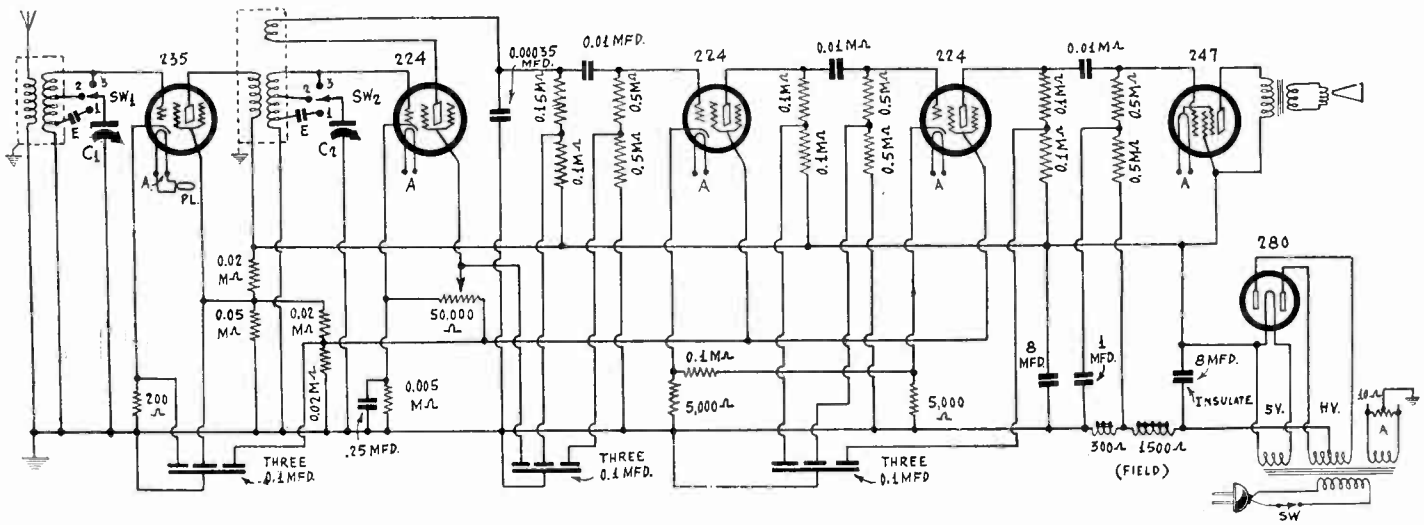

FIG. 1

A great-gain audio amplifier comes in handy for bringing out strongly otherwise weak short wave signals. So this three stage, stabilized resistance coupled audio amplifier is used.

(Continued from preceding page)

adjustment to 1 ma, if that method is pursued, will enable the selection of the biasing resistor without further recourse, since the plate current is known, the screen current is not more than one-third the plate current, and the resistance required therefore would be in ohms, the voltage in volts (5) divided the current in amperes (0.00013), or, 38,461 ohms. The voltage drop across the resistance can not be measured accurately with an ordinary voltmeter, because even if it were of 1,000 ohms per volt sensitivity, of 50 volts full scale, 5 volts would represent 100 microamperes through the meter, and 120 microamperes (approximately) through the biasing resistor. The meter would read too low by far.

Instead of 0.1 ma, more current may flow, as when a lower value of biasing resistor is used, so with 5,000 ohms the bias could be around 5 volts, with the sum of the plate and screen currents almost 4.5 ma, which, however, would be too much current to put through the usual resistors in the plate circuit. The dissipation would be 5 watts, whereas the usual resistor used in this circuit is of the order of 1 watt.

The figure 38,461, however, is not as critical as the exact number indicates. Commercial values of 30,000 or 40,000 ohms could be used.

In the detector cathode circuit, Fig. 1, besides the normal current there is the bleeder current from the potentiometer. At 50 volts for audio screens this current would be 1 ma., so we must use a resistor of around 4,000 ohms, whereupon the commercial value of 5,000 ohms is used. Moreover, a 1,000 ohm per volt voltmeter will measure this voltage on a 50 volt scale or 100 volt scale only a little low.

Bleeder Lowers Required Resistance

As for plate current adjustment, to attain 0.1 ma. at no signal, this may be done by lowering the plate voltage or by increasing or decreasing the value of the biasing resistor. Under no circumstances, however, assume that the bias is developed from the drop caused by plate current only, for the screen current also flows through the biasing resistor.

The foregoing discussion pertains to the 224 as a negative detector bias, but, as intimated, the screen voltage may be lower than recommended, indeed much lower, provided the bias is lower. One objection to lower bias is that in some circuits the signal may cause the grid to swing positive, so that grid current will flow, as it does in grid leak detection, whereupon the desired added selectivity would be lost, and quality would not be so good. Fig. 1 wholly avoids that, as the principal current in the detector cathode is bleeder.

For audio amplification the screen voltage may be 25 volts, the negative bias 1 volt, the plate current 0.5 ma. or, if the screen voltage is lifted, the bias may be lifted. The plate resistor is 200,000 ohms.

The regeneration control may be used as the volume control,

as even after amplification stops (hence regeneration), the output may be cut down, and the audio amplifier is protected from overloading. This is true even though the theoretical gain per audio stage is 1,000 at the values expressly stated in the preceding paragraph.

Nothing to Worry About

The last tube, however, provides a gain of 90. The theoretical gain of 90,000,000 need not cause any anxiety, as nothing like that is attained in practice.

There is a limiting factor in all audio systems, and that is (aside from mere overloading) audio regeneration or oscillation or motorboating. These three names refer to the same thing. The overall gain has to be kept within the stability region.

If any motorboating develops, the grid leak in any audio stage may be reduced to such value as stops this nuisance.

It will be seen that the 250,000 ohms for the detector plate (0.25 meg.) are constituted of two units, one 150,000 ohms, the other 100,000 ohms. So, also the 200,000 ohms values are composed of two 100,000 ohms resistors.

The lower positioned resistor has 0.1 mfd. across it to ground, and the combination constitutes a resistor-capacity filter, wherein the full value of resistance is effective for the low notes, as to signal current, but of course not as to high notes, due to the bypassing effect of the condenser. However, the filters are needed to get rid of hum, and it will be noted the capacity in the pentode grid circuit is 1 mfd., or ten times as high as the other capacities, and for the same reason, hum riddance. Moreover, this system gets rid of the effect of high audio frequency accentuation introduced by the pentode itself.

Audio Regeneration Used

No bypass condensers are needed across the audio biasing resistors, and the one across the detector resistor is there for radio frequency purposes only. Thus accidental regeneration at audio frequencies is avoided—and so much regeneration as is desired or needed for the purpose of cancelling negative feedback is provided by a resistor between the cathodes of the first and second audio tubes. The lower the value of this resistor, the more audio regeneration, but also the higher the resultant bias, so that if values as low as 10,000 ohms are used for this the cathode-to-cathode resistor, then the 10,000 ohms as bias resistors should be reduced, say, to 5,000 ohms each.

The value of the negative bias should not be the one for obtaining greatest output, necessarily, but rather the one suitable for the screen voltage used. Values already have been given. But if the screen voltage were the same for the two preliminary a-f as for the r-f tube, (90 volts approximately), then the bias may be raised to 3 volts, even though this is an audio amplifier. For detection if the screen voltage were 90 volts the

Pep on Short Waves

rated Detector in Tuner

bias might be 7.5 volts negative, but the output is somewhat less than under the previously recommended values of voltages.

The circuit is intended to be built using a dynamic speaker that has field coil that can be served as the B supply choke. If the total d-c resistance of the field coil is 1,800 ohms, and a tap is provided at 300 ohms, the section between tap and ground (300 ohms) will serve for pentode bias, at a little under 20 volts, which may be measured by your meter from tap to ground, while the rest of the voltage (250 volts) may be measured, as to pentode applied plate voltage, from tap to B plus maximum. The reading from B plus maximum to ground is 250 volts. This is applied to the r-f tube as well as to all other tubes, save pentode, but since the plate voltage equals the total voltage less the bias voltage, the plate voltage for all tubes is about as high as that for the pentode. For instance, the r-f tube has a plate voltage of 250 minus 2 or 248 volts, since 2 volts are the bias. The biasing resistor is 200 ohms. The detector is 250 minus 5, or 245 volts applied, the two preliminary audio tubes, 250 minus 2, or 248 volts for the plates, and the power stage, as stated, about 250 volts for the plate. The reason the pentode gets 250 volts is that the plate voltage is measured from field tap (not ground) to B-plus maximum. This is in line with the voltages obtainable from commercial transformers.

Speaker Socket Connections

This is a six tube set, but there are seven sockets, one being used as speaker plug receptacle. The speaker has five leads: three for the two choke terminals and the tap on the choke, two for primary of the built-in pentode output transformer. As you look at the back of the Rola series F speaker (any size cone diameter) the leads are, right to left: ground, tap, B minus and two for speaker, these two being interchangeable.

A suitable method of connection is to put grounded end of field coil to the plate of the socket used as speaker plug receptacle, tap (T) of field coil to grid of the socket, to B minus to cathode and heaters interchangeably to transformer plate and B plus and plate connections.

It should be carefully observed that in using a metal chassis, the first electrolytic condenser, next to the rectifier, must be insulated, the other should not be, since the chassis is to be grounded. Positive B may be taken from either side of the rectifier filament (5 volt winding), and run to the two anodes of the filter condensers and to the plate returns in the set proper. Since the choke is in the negative leg the anodes of the two 8 mfd. condensers are joined, unlike the case where the rectifier choke is in the positive leg, when the choke is between the two anodes.

The choke in the negative leg in itself introduces audio regeneration.

The antenna coupler has 12 turn primary $\frac{1}{4}$ inch from a 30 turn secondary, $1\frac{1}{4}$ inch form, No. 28 enamel wire, taps at 18th and 25th turns from grid end. The other coil has a 15 turn tickler wound over the secondary, and has 20 turn primary.

LIST OF PARTS

Coils

Two shielded coils, as described, one with two windings for antenna coupler, other with three windings for interstage coupler; two taps on each secondary.

One power transformer for six tube pentode circuit.

[Note: Field coil and output transformer are in speaker, listed subsequently.]

Condensers

One two gang 0.00035 mfd. condenser.

Two 20-100 mmfd. equalizing condensers (E).

Three shielded blocks, each block containing three 0.1 mfd. condensers; total, nine capacities. Black lead, common, is to be grounded, reds interchangeable.

One 0.25 mfd. tubular condenser.

One 1 mfd. bypass condenser.

Two 8 mfd. electrolytic condensers, one with two extra insulating washers and a connecting lug.

Three 0.01 mfd. mica fixed condensers.

One 0.00035 mfd. fixed condenser.

Resistors

One 300 ohm pigtail resistor.

Four 0.02 meg. pigtail resistors (20,000 ohms).

One 0.05 meg. pigtail resistor (50,000 ohms).

One 0.005 meg. pigtail resistor (5,000 ohms).

One 0.15 meg. pigtail resistor (150,000 ohms).

Four 0.1 meg. pigtail resistors (100,000 ohms).

Six 0.5 meg. pigtail resistors (500,000 ohms).

One 10 ohm center tapped resistor.

Miscellaneous Other Parts and Accessories

One chassis, 13.5 inches wide x 7.5 inches front to back x 3 inches high, drilled for seven sockets.

Six UY and one UX sockets (three marked 224, one marked 235, one marked 247, one marked "Pent." and one marked "SPKR.").

One vernier dial of the travelling light type, with escutcheon, bracket and pilot lamp.

One dynamic speaker, 1,800 ohm field coil, tapped at 300 ohms; pentode output transformer built in.

One midget cabinet to house chassis, cut for 7 inch cone dynamic speaker.

One a-c cable and male plug.

One rotary selector switch, three circuits, three positions for each circuit; also known as triple pole, three point. Shaft insulated from everything. Keyed knob.

One knob to match, for volume control.

One roll of hookup wire; two do.

Four grid clips.

Two dozen 6/32 machine screws and two dozen nuts.

Two tube shields and bases (for r-f and detector tubes).

Tubes: One 235, three 224, one 247 and one 280.

METHODS THAT AVOID PLUG-IN COILS

THE departure from plug-in coils for wide coverage of frequencies is not complete. Certain accurate devices use such coils, and the procedure is followed at the Grand Island (Nebr.) monitoring station of the Radio Division of the Department of Commerce. Laboratories use plug-in coils.

Those who want to hear short wave programs, however, are prompted by desires of convenience that overpower those of accuracy. In fact, the accuracy does not have to be as high, and precision of calibration is not of paramount importance. A station that comes in at 63 on the dial well may be tuned in next time at 63.2, or the difference may never be noticed, due to the dial itself.

In the use of switching systems, so that from the front panel a knob may be turned, the method of changing principally the capacities does not work out very well. In the first place, the minimum capacity is about the same or the difference too small to be of much assistance. This means that the band coverage is restricted. In the second place, for some uses the ratio of capacity to inductance

is bound to be too high. If regeneration is used, then the set, if it regenerates at the high wavelengths, may be too critical and much of a howler on the low wavelengths. Therefore systems that change the coils only, or both the inductance and the capacity, are favored.

When different coils are used the switching becomes rather complicated. For a tuned radio frequency set there might be the antenna, the r-f grid, the r-f plate, the detector grid and the detector plate to switch, and if there are four positions there are twenty different points. If the switch is a compact one, at the front panel, there are twenty leads to run back and forth, and it is obvious that the circuit becomes unmanageable. Therefore to use such a system a special switch is needed, usually one made for the circuit, so that the moving arm is close to the governed element, and the coil, too, is right near the section of the switch that concerns it.

Even where separate coils are used, it is well to keep them out of one another's fields, to be sure of response all over the dial.

The other choice is that of a tapped coil. If the unused portion is shorted out the result is poor if the eliminated portion is only a small part of the total, and it is better then to leave the unused part dead-ended. However, there are objections to both methods, particularly the losses involved, and while both work, the amplitude declines rapidly as the tapped sections are used, and often there is little or no response at the highest frequencies expected to be tuned in.

The remaining method, using a tapped coil, is to move the stator of the condenser, so that at one position of the switch the full secondary is in use; at the next position, say, two-thirds of the secondary is tuned, the rest continues on to grid as a series impedance; while for one or two more taps a series condenser can be cut in, to keep the inductance to capacity ratio high. The grid return is through the entire coil, anyway, so the series condenser may be included at will.

By this method, at least, the coils may be close together, if shielded, and the leads are reasonably short. It is a handy method.

What to Do When Broadcast and Short Wave Inductances

By Herman

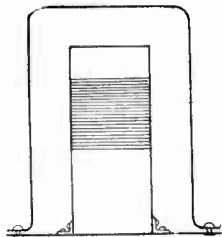

COIL SHIELD SHOULD BE ABOUT TWICE DIAMETER OF COIL FORM, OR MORE. CENTER WINDING ON THE SHIELD NOT ON THE FORM.

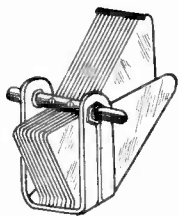

13 PLATES = 0.00025 MFD.
17 PLATES = 0.00035 MFD.
23 PLATES = 0.0005 MFD.
ARE THESE STATEMENTS TRUE?
HOW CAN THEY BE CHECKED EASILY?

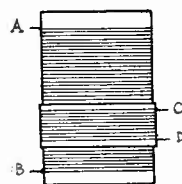

AB = SECONDARY
CD = PRIMARY WOUND
OVER SECONDARY.
A GOES TO GRID
B TO GRID RETURN
C TO PLATE (OR AERIAL)
D TO B+ (OR GROUND)



UNSHIELDED COILS, AS USED IN SINGLE R-F STAGE SETS, IF CLOSE TOGETHER, MUST BE PLACED AT MAGNETIC RIGHT ANGLES TO PREVENT INDUCTIVE FEEDBACK.

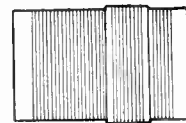

EXPERIMENTERS who go about building their own sets, particularly, if they want to use variable condensers they have, often are stumped as to what type of coil to wind, how many turns, what kind of wire, size of primaries, etc. Therefore some general directions will be given, as well as specific examples for given cases, so that the construction work will not have to be halted until some solution of the coil problem is found.

If unshielded coils are used, and the coverage is for the broadcast band, the inductance of the coil can be figured out, and the number of turns decided for particular diameters to attain that inductance. But the application of the inductance formula is less now than formerly, because unshielded coils are scarcely ever used, except in oscillators and in sets of low sensitivity, even for the broadcast band. When it comes to short waves the formula again is of little use, as the distributed and other stray capacities bear such a large relationship to the total capacity that, for want of knowledge of the capacity, the formula can not be applied. The difficulty with shielding, either for short wave or broadcast use, is that it reduces the inductance and at the same time may increase the capacity, and one does not know the values of these "variable constants."

Solve for Broadcast Band First

One can approach a solution of all the winding problems by first solving for the broadcast band. Then, with a given condenser, the frequency ratio may be obtained. Suppose a condenser tunes, with a given secondary, from 1,700 to 545 kc. This is a ratio of approximately 3.1 to 1. The same ratio will apply to short waves, except as to the tuning of the smallest, and possibly also the second smallest coils, assuming you do not intend to go below 15 meters. If you put on turns of wire experimentally, you would not have to know even the capacity, for the proper inductance would be obtained and the frequency ratio would be an easy result. However, once you know the frequency ratio you know at least the capacity ratio, for the capacity ratio is the square of the frequency ratio. So the maximum capacity in the tuned circuit would be 9.61 times the minimum capacity. If you know the capacity ratio, you can compute the frequency ratio, for it is the square root of the capacity ratio.

Often one does not know the maximum capacity of a tuning condenser. The general rule followed by home experimenters is that a condenser of 23 plates has a capacity of 0.0005 mfd., one of 17 plates, 0.00035 mfd., one of 13 plates, 0.00025 mfd., but of course this is not a safe rule to follow, since capacity depends not only on the number of plates but on their area, thickness and distance from one another. However, an approximation will suffice as a starter, if you lack the commercial rating.

Broadcast Coils

If you think that you have a condenser of 0.0005 mfd., but are not sure, get a piece of tubing $1\frac{1}{8}$ inches in diameter and wind on it 95 turns of No. 31 enamel wire, or any wire of about that size. If the condenser is 0.0005 mfd., then the highest wavelength will come in, on most condensers, around 95 on the dial (550 kc) and the lowest wavelength at around 5 (1,500 kc.) and at all hazards the broadcast band will be covered. These figures will be changed somewhat by the primary, as the effect of a

primary is to reduce the mutual inductance, but if not more than 25 turn primaries of very fine wire are used, the change will not be much, and the coil can be wound with primary over the secondary, near the bottom of the secondary, whereupon the bottom of the secondary should be connected to ground, C minus or other grid return, and the B plus or ground terminal of the primary should be the one nearer the ground of other grid return connection of the secondary. This results in the low potentials being close together and reduces the capacity effect developed by high differences of potentials. Insulating fabric should be put between primary and secondary.

For 1 inch diameter the number of turns, same size wire, may be 107 for 0.0005 mfd., the primary the same as stated heretofore.

These directions presuppose the use of a small shield, say one about 2.5 inches in diameter, of copper, aluminum, zinc composition or the like, but not tin, iron or steel.

Shall There Be More or Fewer Turns?

For the same purposes, but with 0.00035 mfd. capacity, the $1\frac{1}{8}$ inch diameter may have 120 turns and the 1 inch diameter 127 turns.

For 1.75 inch diameter, no shield, the secondary turns, No. 28 enamel wire, for 0.00035 mfd., may consist of 70 turns, whereas if a $3\frac{1}{4}$ inch or larger diameter shield is used, copper or aluminum, the number of turns may be 80. For 0.0005 mfd. the number of turns of the same kind of wire, unshielded coil, would be 85, and for shielded coils would be 105 turns. The primaries may consist of 15 turns of fine wire wound as previously directed for the smaller diameter coils.

So, without actually knowing the capacity of a condenser, it is easier to estimate what it is, and test out on the basis of the coil data given. The coil, by adding an extra plate feedback winding and using a high series adjustable resistor in the plate circuit (500,000 ohms) may be made regenerative by you so you can get better definition of dial readings. You will have to be able to put on more turns, if necessary, to get lower capacity dial settings for given frequencies, in other words, to tune to higher wavelengths, or may take off turns to tune to lower wavelengths, which will provide higher capacity dial readings for given frequencies. It is important to bear in mind that if a set does not tune to higher enough wavelengths *more turns are needed*, and if it does not tune to low enough wavelengths *fewer turns are needed*. An exception exists where the primaries are too large, that is, have too many turns or are too closely coupled. The foregoing directions do not inflict excessive coupling of this nature, but some coils have grossly oversized primaries that cut down the frequency ratio because of the high capacity they introduce. The remedy of course is to cut down the size of the primary, either the number of turns, or, if more convenient, the distance of primary from secondary.

Difference in Capacities

The number of turns given for the primaries presupposes the use of screen grid tubes. If general purpose tubes are to be used the number of primary turns should be half of that stated. In general the primaries for screen grid tubes presuppose the use of three tuned circuits. However, if four tuned circuits are to be used in a tuned radio frequency set, then the number of

Stumped on Coil Data

Determined Without Knowing Actual Capacity

Bernard

primary turns should be reduced 25 per cent. from what was given.

Now it is assumed that you have wound three or four coils and put them in a set. All coils are exactly alike. Even the antenna coupler may be the same as the interstage couplers, except that for general purpose r-f tubes (201A, 199, 227, 226, etc.) when the antenna coupler may have twice as many primary turns as have the interstage couplers. Note that this does not apply to antenna couplers used with screen grid tubes.

Even though the coils are exactly the same, the circuits have to be trimmed, for the capacities in them differ. Therefore equalizing condensers are put across the main tuning condensers, and are adjusted. Regarding such adjustment, it will be found that all detector circuits tend to have a higher input capacity than amplifier circuits, so the trimming condenser for the detector input tuning capacity may have to be set at zero. Also, the antenna stage trimming condenser.

The Uncertain Antenna Stage

Greatest uncertainty exists as to the antenna coil trimming. If a long antenna is used, say, 100 feet total, including lead-in, the capacity introduced across the primary, which may be 0.00025 mfd., is partly reflected in the secondary, and therefore not much of the trimming capacity has to be used, but if a short or indoor aerial is used it is likely the antenna trimmer will have to be turned down most or all of the way (maximum capacity). You should select some particular frequency on which to establish this peaking, preferably around 1,000 kc. (300 meters), either by picking out a distant station or by tuning in a local station and turning the volume control down until the signal can just be heard. Then the relative effect of the trimming adjustment will be more pronounced on the ear. If you have an output meter, which is an a-c voltmeter, you may connect this across the speaker primary and make the adjustment of the basis of greatest needle deflection.

By following these directions you will have a set of coils that will function properly, but of course you must use shielded coils if you are to have two or three stages of t-r-f. Even if there is only one t-r-f stage, no shielding, some precautions against inductive feedback should be taken, such as placement of the two coils at magnetic right angles.

A Few Extra Turns

This much accomplished, you have a ready means of ascertaining the frequency ratio. Since the frequency is approximately proportional to the number of turns, you can tell how many turns for a lower band of wavelengths.

In one case we had a frequency ratio of 3 to 1, approximately, which holds true of 0.00035 and 0.0005 mfd. condensers, as a rule, or the ratio is a little higher, and if the secondary had 127 turns, the next secondary, if an independent coil, or a tap, seemingly would have to be at 47.3 turns. But we desire some overlap, and besides the ratio does not hold excellently, principally because the diameter is the same, the wire is the same, the number of turns fewer, and the relationship of axial length of winding to diameter changes, so to avoid taking unnecessary chances, add a few turns, and put on 50 turns for this secondary, or locate a tap 72 turns from the grid end, for moving the condenser stator to a tap thus 50 turns from the ground end. For the next coil 16.7 turns seemingly would be necessary, but again we add a few, and make the number of turns 20. For succeeding coils we could cut the ratio to 1-to-2, would have 10 and 5 turns respectively, and there would be considerable overlapping, but we would be avoiding the difficulty of missout. The old ratio does not stand up for the small coils, probably due largely to the shape factor of the coils.

Dynatron Requirements

Nothing has been said about primaries for independent short wave coils. However, a ratio of 1 to 5 may be followed all the way through, for separate short wave coils. If ticklers are to be used they should be closely coupled to the tuned secondaries and consist of one-third the number of turns that is on the secondaries, except for the two smallest coils, when the ratio may be 1 to 0.8 oscillator coils with feedback plate windings are included in these directions.

There is one form of oscillator that does not require a feedback coil, for it depends on the negative resistance in the tube. The plate circuit is tuned, instead of the grid circuit. This is the

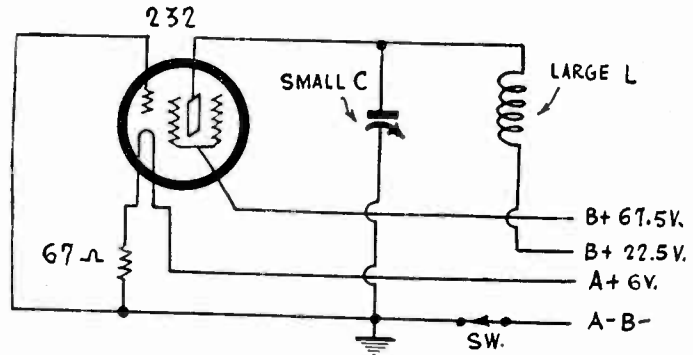

DYNATRION OSCILLATOR, USING THE 232 SCREEN GRID TUBE. THE SCREEN VOLTAGE IS LOWER THAN THE PLATE VOLTAGE. DETERMINE REQUIRED VOLTAGES EXPERIMENTALLY, AS THEY DIFFER WITH DIFFERENT TUBES.

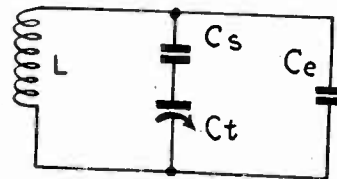

L IS THE OSCILLATOR SECONDARY OF A PADDED CIRCUIT, Cs THE SERIES COND., Ce THE EQUALIZING CONDENSER, AND Ct THE TUNING CONDENSER

dyanatron oscillator. It is a fairish one, of 1 to 5 per cent. frequency error, and it requires, more than does the feedback plate coil system, a high ratio of inductance to capacity.

The use of the large condensers for tuning in broadcast wavelengths does not make for the best dynatron results on short-waves. It is a method that suffices only when one does not expect to tune down very low—for instance, to 75 meters or so—or where one desires to build a converter, and the plate feedback coil method is used, which assures oscillation all the way down, say, to 15 meters. But the dial readings become crowded nevertheless. This is due to the rapid change of capacity where small capacity changes effect large changes in frequencies. Hence large capacity changes effect ever so much larger frequency changes.

To develop a high inductance to capacity ratio requires only that the inductance shall be high in respect to the capacity, and while that is only a phrase unless defined, it applies mostly to the use of the higher capacity settings of the condenser, for of course the ratio changes in favor of the desired ratio as lower capacity settings are used. This is because the inductance remains virtually constant although the capacity is decreased.

27 Mmfd. Measured Minimum

It is not necessary to use separate condensers, for a series condenser will cut down the maximum and all intermediate capacities. For instance, a 0.0001 mfd. fixed condenser, e.g., a 20-100 mmfd. equalizer set at maximum, placed in series with a 0.00035 mfd. condenser, would give you a maximum of about 90 mmfd., while the minimum might be 30 mmfd., due to the wiring, the tube, the minimum of the main condenser and other irremovable capacity effects. The minimum does not change much even when series capacities of small values are used.

Actual measurements made in a receiver using 0.00035 mfd. showed that the total minimum was 27 mmfd., so the allowance

(Continued on next page)

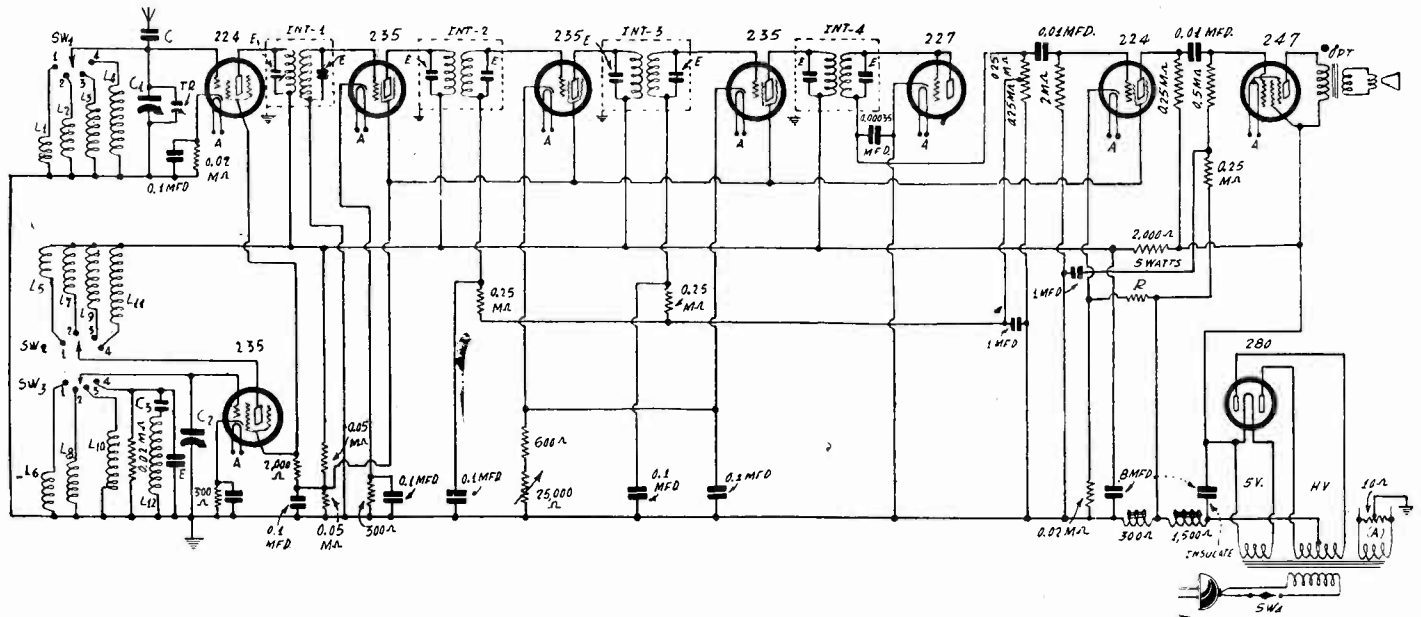

Directions for winding coils may be applied to a circuit such as this, including even the padding of the broadcast band oscillator coil.

(Continued from preceding page)

of 30 mmfd. is well supported by experiment. The ratio therefore for 0.00035 mfd. maximum, as against 30 mmfd. minimum, was better than 1 to 10, but the series condenser reduced the capacity ratio to 1 to 3, so with the smaller capacity the frequency ratio was a little more than 1 to 1.7 for the 30-90 mmfd. variation. So the reduction in number of turns would be to 10/17 from one coil to another, but there is a snag, in that the switch is made from one ratio to another. Therefore use the series combination on the broadcast band to test out the ratio of frequencies and wind enough turns for the next coil to bring in the highest broadcast frequency, and obtain the winding data for the rest of the coils by the taking 10/17 (or the ratio obtained experimentally) of the previous number of turns, and adding one turn for overlap. Of course there will be more coils to cover a given group of bands, but the results will be better.

Oscillation Test for L-C Ratio

At all hazards, every coil can be tested, and it will be found that the directions come pretty close to being right, except that you must reduce the ratio for the two smallest coils to be sure of overlap as to tuning these two coils.

Just what the inductance to capacity ratio should be you will not be able to ascertain in figures, but an experimental test is that when the coil is hooked up as a dynatron oscillator it should oscillate at all settings of the condenser.

It can be seen that winding the short wave coils is experimental work, anyway, and empirically is about the only way you can do the job. However, the previous guiding remarks will lessen the labors.

The remaining coil problem concerns the padding of superheterodyne circuits. Where the intermediate frequency is relatively high (say, 150 kc or more), then the oscillator condenser has to have its capacity reduced, and suitable inductance selected accordingly. This is described variously as no problem at all,

or quite a problem, and those who say it is no problem usually look a bit worried when they sit down to pad a circuit for their own use.

Simplified Tracking

However, the subject was well covered in an article entitled "Making the Oscillator Condenser Track," by J. E. Anderson, printed in the November 28th issue, pages 8, 9 and 10. This was a mathematical discussion, principally, but it wound up with the following suggestion to those who must do the work without the aid of mathematics or instruments, when the i-f is 175 kc:

"In a practical case of padding without instruments, choose a series capacity approximately that computed. Start with an oscillator coil having too many turns. Set the tuner of the receiver at a station near 550 kc. Change the oscillator inductance by removing a turn at a time until the signal comes through loudest. Try the circuit by tuning in other stations. The results may be improved by retuning the intermediate frequency amplifier, as the padding may be just right for a slightly different intermediate frequency."

Since the above relates to a method that is entirely experimental, nevertheless one that gives results, some idea of the value of the series condenser is necessary. For 0.00035 mfd. tuning capacity the series condenser may be 0.001 mfd., and for 0.0005 mfd. it may be 0.0015 mfd. Besides the series condenser, a parallel trimmer is advisable, and may be a 20-100 mmfd. equalizer. The requirement for a coil having too many turns is met simply by using at first a coil that has the same number of secondary turns as has the modulator secondary. There is no objection to changing the intermediate frequency slightly, as recommended, as there is nothing sacrosanct about the intermediate frequencies generally used. Many so-called 175 kc. channels are 180 kc. or 170 kc. or some other frequency close to 175 kc.

Rolph Proud of Columbo's Rise

Russ Columbo, the National Broadcasting Company's "Voice from the Golden West," prizes a letter from James Rolph, Governor of California, which says:

"For California, I wish to extend heartiest congratulations. When, over the National Broadcasting Company's system, I hear your theme song 'You Call It Madness, but I Call It Love,' I know it is a time for relaxation and joy. You have a marvelous voice, and your soothing, melow tones come in wonderfully to your listeners on the Pacific Coast. California is very proud of San Francisco's son and wishes him a long life of happiness and continued success."

Literature Wanted

Readers desiring radio literature from manufacturers and jobbers concerning standard parts and accessories, new products and new circuits, should send a request for publication of their name and address. Send request to Literature Editor, RADIO WORLD, 145 West 45th Street, New York, N. Y.

Clayton Chase, P. O. Box 231, Danielson, Conn.
Heighes Bros., Sharon, Pa.
A. G. Brooks, 909 Marshall St., Louisville, Ky.
Theodore W. Kaepffel, 671 Main St., W. Springfield, Mass.
Robin Matthew, 5 St. Michael Place, Charleston, So. Car.
Comrie Watt, Rose Hill Farm, Rivoli, N. Y.
D. V. Lawell, 1548 George St., LaCrosse, Wisc.
Walter Daugherty, 139 S. Pleasant Ave., Dallas-town, Pa.
Sid Hester, McNab, Ark.
Van G. Winegard, St. Regis Hotel, Saranac Lake, N. Y.

Why Announcers' Diction Improved

Several years ago a man entered the studio of WOR, in Newark, N. J., and announced that nothing irritated him so thoroughly as the voice of one of the announcers and that he had brought along a razor to put an end to the annoyance.

He was finally subdued by the staff and subsequently sent to an insane asylum. Word was received recently that he had been released and the announcers are paying particular attention to their diction.

SHORT WAVE TUNERS

NEXT WEEK, issue of December 26, will be published an article on short wave tuners for battery and a-c operations with coil data given. Be sure to read it.

A Band Pass Super

Compact Assembly for an Eight Tube Set

IN the construction of a superheterodyne for one's own use it is well to avoid the so-called autodyne system, wherein the modulation and oscillation take place in the same tube, as this method presents difficulties. The harmonics are strong. The frequency stability may be of a low order, and one desires to avoid frequency drift as far as practical—farther, no doubt! The coupling between modulator and oscillator is effectively unity, and we desire loose coupling, or if special coupling reduction precautions are taken, and the modulator tube is tuned to the incoming frequency, the oscillation may result at that frequency, instead of at the desired difference frequency (carrier frequency minus intermediate frequency). So it is better to keep the two functions separate.

Why Eight Tubes Are Advisable

To achieve a high order of results eight tubes are advisable, which allows for only one stage of audio, one tube being used in the r-f stage, two tubes in the mixer, two in the intermediate, one as detector and the two others as power tube and rectifier. While it is practical to reduce the number of intermediate stages to one and get fairly decent results, the two-stage gain is the minimum for the degree of pep one expects from a superheterodyne he builds himself. The present circuit provides that kick, yet the intermediate channel does not develop the fullest possible sensitivity, as there is another consideration, that of quality, to be satisfied.

Suppose that we made the intermediate channel as selective as we could. It could be too selective, when considered with the selectivity of the t-r-f stage and modulator. Therefore a band pass filter circuit is used, consisting of two 800 turn honeycomb choke coils, spaced $1\frac{1}{8}$ inches apart, each tuned by a 20-100 mmfd. equalizing condenser.

As explained in the December 5th issue, in which there was preliminary discussion of the same circuit, the condensers may be disconnected from the plate coils of the intermediate couplers, and only the grid condensers tuned for maximum response. Then the grid condensers are disconnected temporarily and the plate condensers re-established and tuned. Next the grid condensers are reconnected. The result is a band pass filter intermediate amplifier, of less gain than would be afforded if both circuits were peaked for maximum, but with an admittance band closely confined to 10 kc.

Detuning by Volume Control

It is not altogether easy to do this peaking under any circumstances, with or without band pass filter effect, but it is essential to use an insulated device instead of a metal screwdriver for adjusting the compression type condensers, and it is advisable to use an output meter. The volume control should be set at a given position, the half way mark being as good as any, and all d-c voltages measured. Then when the tuning adjustment is made it may be considered correct for those voltage conditions. Any alterations of the volume control setting will detune the intermediate channel a little, but not enough to require any special precautions, because the intermediate frequency is low in respect to all other radio frequencies in the set, and the actual frequency change is least in the intermediate channel for that reason. If the intermediate frequency were 1,600 kc then the volume control in the specified position would be out of the question. The frequency change then would be more than 9 times as great.

Antenna Series Condenser

In line with the construction of a powerful intermediate amplifier, which easily may have a gain of a few thousand, the input should be low, and therefore a small series condenser is used in the antenna circuit. This is simply a method of loosely coupling the antenna to the first tube. If a 20-100 mmfd. equalizer is used, then it may be set at maximum, or close to maximum, depending in part on what adjustment best teams up with the tuning of the modulator and oscillator stages, particularly the modulator.

It will be found usually that the modulator circuit has a larger input capacity than the other circuits (except second detector), and even larger than the first r-f tube, for the antenna capacity becomes small, in consideration of the series antenna condenser. As a long aerial will not be used with such a set the antenna capacity effect, due to the series condenser, may be less than 50 mmfd., which is small, considering the fact that most tuned circuits have a minimum capacity of around 30 mmfd., allowing for condenser minimum, wiring, tube capacity, etc.

Reflected Capacity

The tuning of the modulator plate circuit reflects back into the grid circuit an added capacity, which is about the same situ-

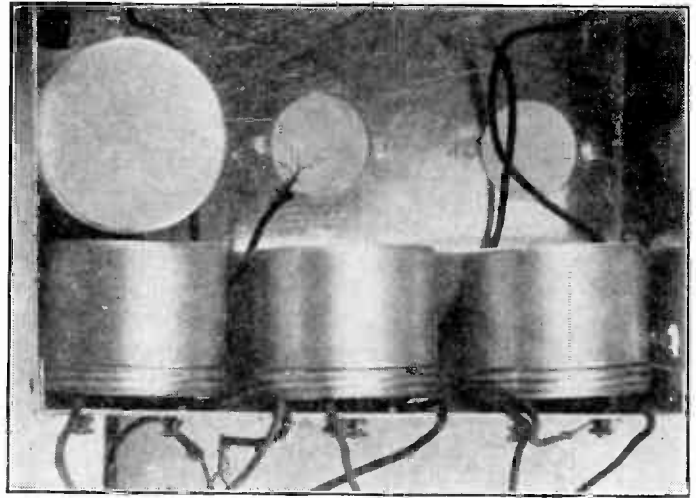

FIG. 1

The three shields in a row contain the intermediate frequency transformers, mounted on the left side of the chassis. They should be put in position before the r-f coils are mounted under sockets.

ation developed from the plate bypass condenser in the second detector. The bypass condenser in standard detectors, and the plate tuning of modulators, account largely for the extra high input capacity of the tubes in these circuits.

The negative bias on the 235 r-i tube is around 1.5 volts, that of the modulator is around 2.5 volts, as the plate voltage is low, and modulation results. This plate voltage may be around 90 volts, since it is the screen voltage of 235 tubes, and such voltage will result from the distribution according to the specified values of the resistors. The screen voltage for the 224 modulator itself is obtained from the oscillator circuit.

The Special Mixer Coupling

The cathode of the oscillator is positive in respect to ground by about 10 volts, for a 227 tube is used with around 180 volts on the plate. Therefore if the screen of the modulator were connected to cathode of oscillator there would be 10 volts on the modulator screen. What is desired is around 30 volts, and besides oscillation frequency has to be picked up, which would not be true of modulator screen connection to oscillator cathode, for the biasing resistor of 1,200 ohms in the oscillator cathode circuit is bypassed.

Therefore two greatly dissimilar resistors are put in series, the smaller value toward the oscillator cathode, and some of the radio frequency voltage in the oscillator grid circuit is added to the cathode voltage, and the voltage on the modulator screen therefore is lifted. It is assumed that for 30 volts on the modulator screen there will be 20 volts from the oscillator, of which 10 volts are d-c and 10 volts are a-c. This, of course, indicates that there may be as much as 240 volts of radio frequency across the oscillator grid, not a far-fetched assumption. The voltage in the grid circuit is far greater than that in the plate circuit of the oscillator.

Relatively Constant Coupling

The grid bias of the oscillator would be prevented were no stopping condenser used, so 0.0015 mfd. is inserted, which is comparatively large enough to maintain the constancy of coupling despite different frequencies generated by the oscillator, which is the prime object of this special form of coupling. However, the condenser may be made larger, if desired, only it should not be much smaller.

The 227 tube is a good choice for oscillator, because a good wave form exists, much better than in the case of the dynatron oscillator. The low order of harmonics makes the 227 preferable.

Of course the power is high, in the 227, and it would be easy to overload the subsequent system even without any signal, that is, the oscillation is intense enough to cause blasting, even without any modulation present, or any augmentation by carrier amplitude. However, as intimated, the solution is loose coupling, which not only maintains the independence of the two tuned circuits, modulator and oscillator, but also purposely enfeebles the output of the 224 modulator, a tube that is an excellent

(Continued on next page)

Constant Coupling in a A-C Voltage in Oscillator Added to Bias

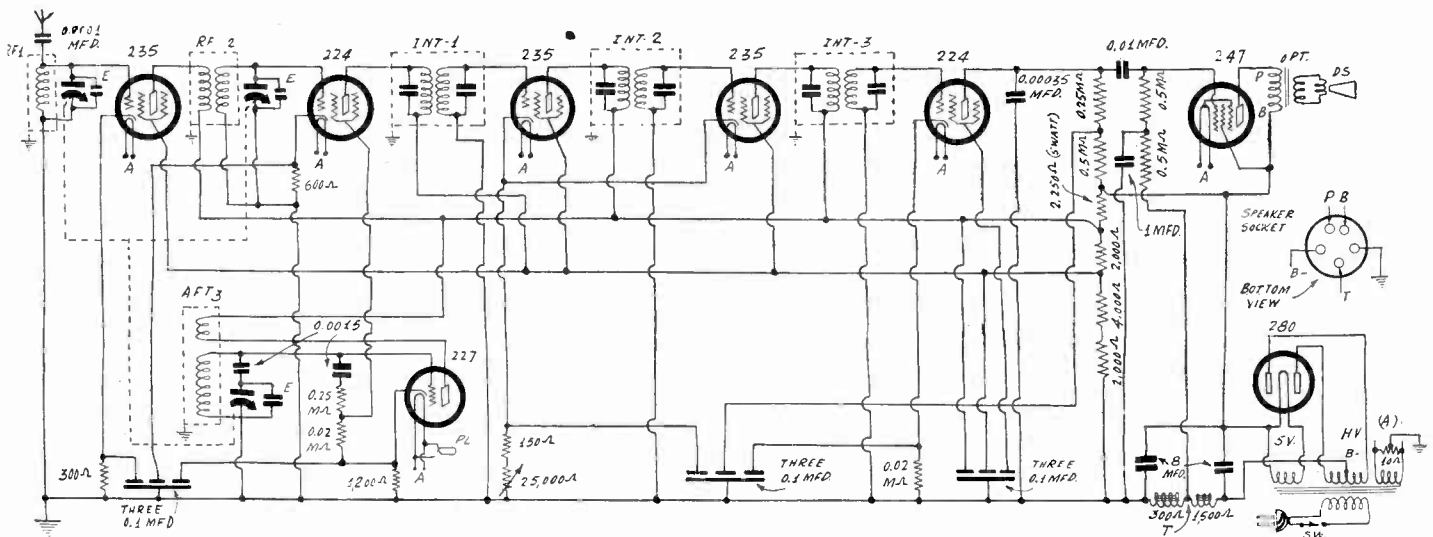

FIG. 2

The coupling of modulator (224) and oscillator (227) is effectuated through modulator screen connection to the joint of two dissimilar resistors. The 0.0015 mfd. stopping condenser is necessary to preserve oscillator bias. See text for discussion of second detector screen voltage.

LIST OF PARTS

Coils

One impedance r-f coil for 0.0005 mfd., one interstage r-f coupler, one oscillator coil, three intermediate frequency transformers, 175 kc, with condensers built in. All coils shielded.

One power transformer for 247, 280 and six heater tubes. (Note: B supply choke coil and power tube output transformer are built into speaker specified later.)

Condensers

One three gang 0.0005 mfd. tuning condenser with trimmers built in.

Two 0.0015 mfd. fixed mica condensers.

One 20-100 mmfd. equalizer (antenna series condenser).

Three shielded blocks, three 0.1 mfd. condensers in each block; total, nine capacities; black common; reds interchangeable.

Two 8 mfd. electrolytic condensers, one with two insulating washers and a connecting lug.

One 0.00035 mfd. fixed mica condenser.

One 0.01 mfd. fixed condenser.

One 1 mfd. bypass condenser, 200 volts.

Resistors

One 300 ohm pigtail resistor.

One 600 ohm pigtail resistor.

Two 0.02 meg. (20,000 ohm) pigtail resistors.

Two 0.25 meg. (250,000 ohms) pigtail resistors.

Three 0.5 meg. (500,000 ohms) pigtail resistors.

One 150 ohm pigtail resistor.

One 25,000 ohm potentiometer with a-c switch attached.

One 1,200 ohm resistor.

Two 2,000 ohm pigtail resistors.

One 4,000 ohm pigtail resistor.

One 2,250 ohm 5 watt resistor.

One 10 ohm center tapped resistor, 5 watt.

(Note: Resistors are 1 watt unless otherwise specified.)

Miscellaneous Other Parts and Accessories

One dynamic speaker, 1,800 ohm field coil, tapped at 300 ohms; pentode output transformer, also built in.

One chassis, 14x9x3 3/8 inches, with provision for seven sockets and for two 8 mfd. electrolytics on top, and speaker socket at rear.

Three UY sockets marked 235, two UY sockets marked 224, one UY socket marked 227, one UY socket marked "Pentode," one UY socket marked "Speaker" and one UX socket marked 280.

One vernier dial, traveling light type, with escutcheon, pilot lamp and knob.

One midget cabinet to house chassis.

One knob, for volume control.

One a-c cable and plug.

Three dozen 6/32 machine screws and three dozen nuts; one dozen threaded 6/32 bushings, 5/8 inches high.

(Continued from preceding page)

modulator but does not stand much. The whole theory of the circuit is to develop the gain substantially in the set's intermediate frequency amplifier, and to cut down the amplitude in preceding circuits, by the coupling, to give the intermediate channel and the audio stage free rein.

Second Detector Screen Voltage

The second detector (224) screen voltage is not shown, but the voltage divider affords two different voltages, and the connection is to be made to the one that gives the louder response. These two points are the juncture of the 2,000 and 4,000 ohm resistors on the grounded side of the voltage divider, and the extreme of the 4,000 ohm resistor used for screen voltages on the other tubes. Detection results at either connection, but the option is presented so that a low or a high screen voltage may be selected. If the screen voltage is low the bias should be low (e. g., 20 volts screen, 2.5 volts negative bias for detection), or if the screen voltage is high, the bias should be high (90 volts and 6 volts). The normal recommendation is for 5 volts negative bias for detection, at 20 to 45 volts on the screen. Of course the screen voltage affects the amount of plate current, and at a high screen voltage (90 volts) the current would be around 0.3 ma, and the bias 6 volts negative. The voltage effective on the plate, with 275 applied, would be a little less than 50 volts.

Parts Fit on Small Chassis

The parts may be put on a chassis 14 inches wide by 9 inches front to back, by 3 3/8 inches high. The layout was shown in the December 5th issue. To arrange the parts thus, the three intermediate transformers would have to be put in a row at one side, preferably the left-hand side as you look at the front panel.

RADIO WORLD

ADVERTISING RATES

	4 consec. Inser. (ea.)	13 consec. Inser. (ea.)	26 consec. Inser. (ea.)	52 consec. Inser. (ea.)
1 Inser.	10%	12 1/2%	15%	20%
1 page	\$150.00	\$135.00	\$127.50	\$120.00
1/2 page	75.00	67.50	63.75	60.00
1/4 page	50.00	45.00	42.75	40.00
1/8 page	37.50	33.75	32.81	30.00
1/16 page	25.00	22.50	21.87	20.00
1/32 page	18.75	16.87	16.41	15.00
1 inch	5.00	4.50	4.37	4.00

Classified advertisements, 7 cents a word; \$1.00 minimum; must be paid in advance.

Advertising Department

Radio World, 145 West 45th St., New York, N. Y.

Super-heterodyne Mixer

Voltage to Supply Modulator Screen

This left-hand side is the lower part of Fig. 1. The intermediate transformers have mounting screws and the chassis therefore must not have open sides, otherwise you'd be left without a place to mount these transformers. Two panel side holes for each transformer permit adjustment with an insulated driver.

The three coils for the t-r-f section and oscillator are mounted under the sockets to which they apply. Fig. 1 shows two socket holes (toward the front of the chassis, at right in diagram), with one r-f transformer mounted. If the two extreme i-f transformers are mounted with screws on parallel upright lines, the middle transformer should be mounted with screws on a horizontal line, as this places the coils of either extreme transformer at right angles to the coils of the middle transformer.

These intermediate frequency transformers are of the 175 kc type, in aluminum screw cap shields, 2.5 inches diameter, 2.25 inches high.

Fig. 2 shows the circuit diagram, with detail at right for connection to a ninth socket (at rear of chassis) used for speaker plug receptacle. The bottom view of this socket is shown, with tap (T) of the 1,800 ohm field coil of the dynamic speaker going to grid, cathode to B minus, plate to ground, and heaters interchangeably to primary of the output transformer built into the speaker.

The value of the series condenser for the oscillator tuning is given as 0.0015 mfd. Therefore the same secondary may be used as for the other r-f coils, turns taken off for matching, while the erstwhile primary is used for feedback. For 0.0005 mfd., use 1 1/8 inch diameter tubing, secondaries 100 turns of No. 31 enamel wire, or similar sized wire; primary wound over secondary, insulating wrapper between, 25 turns of any kind of fine wire. The antenna impedance coil is "secondary only," also 100 turns. You will stop on the oscillator pick-off at around 90 turns.

Vertical Aerial Favored

By Hollis Baird

Chief Engineer, Short Wave and Television Corporation.

Most short wave enthusiasts use their regular broadcast set antenna for short wave reception. Most of these antennas are the long horizontal type with a vertical lead-in. Short wave reception is often marked by fading. While short waves may inherently fade some, actually much of this is due to the receiving antenna used.

Vertical antennas are now being erected by leading broadcasting stations for transmitting purposes. This same antenna is the kind that should be used for eliminating much of the fading now experienced on short waves and even on broadcast waves.

Incidentally, the vertical antenna makes for a much neater looking job on any house and in many instances makes the erection of an antenna simpler, since the long stretch of the ordinary flat top demands two points of suspension, well apart, with resulting guying and usually a bad sag which tends to swing in a high wind and in so doing does not aid reception by any means.

Keep Away from Wall

A vertical antenna is practically the present lead-in. It should be kept a couple of feet away from any structure, if possible. To obtain this it may slope a bit upward and be connected to a short cross wire running from a tree to the house, care being taken, however, that the vertical portion be completely insulated from the flat top portion, which merely becomes a supporting wire for the vertical antenna.

Apartment houses are particularly desirable locations for vertical antennas since, if many flat tops are attempted, the roof becomes a maze of cross wires, and one wire invariably breaks and falls across the rest, shorting them out and ruining reception. The vertical antenna in this instance can run from the apartment up to the roof, being held off from the building by a one or two foot stick, preferably the latter, at either end.

Improved Reception

This applies to the lower apartments. Upper apartments, with only a few feet to the roof, may erect a short pole at the edge of the roof and get extra height by dropping the vertical antenna from the top of the pole to a short stick at right angles to the building extending outward from the window sill.

On a single house the chimney is usually the logical place to use for supporting a vertical antenna, but the window through which the antenna comes into the living room is usually some feet from the chimney. In this case the vertical antenna should be erected up the side of the chimney but held off as in the case of the apartment house wall and then a short wire run from it at the bottom over to the window through which the antenna ordinarily enters.

All radio listeners changing over to this type of antenna should find improved reception from a fading viewpoint and in listening-in on short waves particularly marked improvement in reducing the effect of fading should be experienced.

Each week names and addresses of new members of Short Wave Club are printed.

- Sammie W. Lee, care of Geo. Adelson, E. Pensacola Heights, Pensacola, Fla.
- Willys L. Smith, 229 North Park St., Shawnee, Okla.
- Charles Teates, Box No. 8, Hanover, N. J.
- J. D. Koontz, Jr., P. O. Box 4, Waupaca, Wis.
- Fred. Jaye Bruno, 140 St. Marks Ave., Brooklyr, N. Y.
- A. Karas, 237 N. Stratton St., Gettysburg, Pa.
- Harry W. Gaunt, 524 Broad St., Meriden, Conn.
- Byron Lowery, 1418 Walla Walla Ave., Walla Walla, Wash.
- John O'Donnell, 205 Ardmore Ave., Ardmore, Pa.
- Nott Terrace Radio Club, Nott Terrace High School, Schenectady, N. Y.
- Boyd Russell, 4304 New York Ave., Des Moines, Iowa
- Ernest H. Benson, 662 Court St., Elko, Nevada
- Justin Versace, 649 Broad St., Rochester, N. Y.
- Jack Tinkle (Dozier Route), Shamrock, Texas
- S. H. Parsons, Jr., University of Alabama, Box 289, University, Ala.
- John M. Habets, R. D. 3, Bethel, Vermont
- R. J. Matthias, K P R C, Houston, Tex.
- C. C. Hartwick, P. O. Box 456, Tulia, Texas.
- L. Willett, 38 Mallon Rd., Dorchester, Mass.
- Charles Taylor, 5009A Mardel, St. Louis, Mo.
- William H. Jago, 106 Main St., Ambler, Penna.
- Steve Horbach, 219 Plain St., Taunton, Mass.
- Virgil K. Haldeman, 310-A E. Whittley, P. O. Box 1483, Avalon, Catalina Island, Calif.
- Ralp McVey, 3605 No. Eleventh St., Philadelphia, Pa.
- E. Osborn, R. F. D. No. 1, Box 795, Joplin, Mo.
- Leslie Fonger, 58 Concord Ave., Muskegon, Mich.
- H. W. Jones, 2120 Delaware Ave., Swissvale Sta., Pittsburgh.
- William S. Turner, 16 Barker St., Methuen, Mass.
- John W. Hoke, 216 Cottage St., New Castle, Pa.
- John W. Anderson, Jr., 1308 Michigan Ave., Buffalo, N. Y.
- Edward G. Smith, 16 Court St., Brooklyn, N. Y.
- Strathmore A. Johnson, 19 W. 54th St., New York, N. Y.
- Adam Talbert, Route 4, Box 151, Salisbury, N. C.
- Paul D. Wallace, 706 W. 180th St., New York, N. Y.
- C. E. Reid, 82 Alanson Road, Bridgeport, Conn.
- George Hewitt, 915 Atlantic Ave., Brooklyn, N. Y.
- C. E. Gallagher, 77 Winter St., Lynbrook, L. I., N. Y.

Short Wave Club

ARE you interested in short waves? Receivers, transmitters, converters, station lists, trouble shooting, logging, circuits, calibration, coil winding—what not? If so become a member of Radio World's Short Wave Club, which you can do simply by filling in and mailing attached coupon. Or, if you prefer, send in your enrolment on a separate sheet or postal card. As many names and addresses as practical will be published in this department, so that short wave fans can correspond with one another. Also letters of general interest on short wave work will be published. Besides, manufacturers of short wave apparatus will let you know the latest commercial developments. Included under the scope of this department is television, which is spurting forward nicely.

Short Wave Editor, RADIO WORLD, 145 West 45th St., New York.

Please enroll me as a member of Radio World's Short Wave Club. This does not commit me to any obligation whatever.

Name

Address

City..... State.....

Much Progress in Stabilizing

Two Methods, Not Using Crystal Control

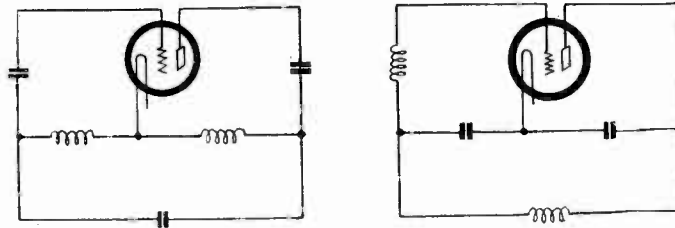

F. B. Llewellyn uses capacity for frequency stabilization of oscillators, rendering the frequency constant despite terminal voltage changes, except as to the temperature effect of voltage changes due to current differences. At left is the Hartley oscillator, with the left and right hand condensers as stabilizers. At right is the Colpitts oscillator.

OSCILLATORS is the principal topic discussed in technical papers in the December issues of "Proceedings of the Institute of Radio Engineers." Two of these have to do with frequency stability, and these are "Constant Frequency Oscillators," by F. B. Llewellyn, Bell Telephone Laboratories, New York City, and "A Recent Development in Vacuum Tube Oscillator Circuits," by J. B. Dow, Bureau of Engineering, Navy Department, Washington, D. C.

Mr. Llewellyn's article deals with the stabilization of popular types of oscillators against frequency variations due to battery voltage changes. As the stability desired is somewhat akin to that obtainable from a crystal controlled oscillator, batteries are used for terminal voltage, as a first precaution, and then the methods applied for keeping the frequency constant despite the changes in voltages at the batteries. These changes would be due to variations introduced in tests, ageing of the batteries, and under some circumstances extra drain.

Require Greater Accuracy

Of course, variable frequency oscillators are the most flexible, and the author treats of these, too, showing how the proper choice of loads and constants will make the stability frequency of a high order.

"In recent years," says he, "the commercial requirements of vacuum tube oscillators have grown more rigid. The tremendous increase in the number of radio broadcasting stations with the consequent narrowing of frequency band available to each, the analogous demands by the carrier telephone, and the tendency toward higher frequencies where a small percentage frequency change defeats the universal effort to secure better quality, all have united in creating a need for very constant frequencies.

"This need has led to a study of methods for holding the frequency constant. The most notable of these is the piezo-electric crystal. However, it has been known for some time that certain oscillator circuits have the inherent property of maintaining their frequency quite constant even though not crystal controlled. Some of these circuits have the additional advantage of combining constant frequency at a given wavelength with the ability to maintain this constancy at other wavelengths, thus giving a range of available frequencies, any one of which may be depended upon to stay constant.

Causes of Changes

"The elements which cause the frequency of oscillators which are not crystal controlled to vary are such things as vibration, changing temperature, fluctuating voltage, and changing load. Vibration and temperature affect primarily the inductance and capacity in the circuit, which naturally causes the frequency to change. Fluctuating voltages change the tube resistance, which in turn affects the frequency. Changing loads also change the frequency, since they take the form of variable resistance and reactance."

The problems connected with vibration and temperature are not taken up by the author, who confines himself to a solution of the load problem and the variable voltages, applying his remedies to standard oscillators.

He stresses the importance of the grid resistance and plate

resistance, as variations in voltages produce a variation in these two circuits, usually in opposite directions.

Method Used

The author then dissects the Hartley and Colpitts type oscillators and shows methods of grid and plate stabilization, individually and combined. The author's method is to compute the value of capacity necessary for insertion between grid and tuned circuit or between plate and tuned circuit, where the oscillator consists of two coupled coils, terminating at a common filament, and tuned across the extremes by a variable condenser. The stabilizing condenser then would be connected from plate to the high potential side of the plate coil, or for grid stabilization, from grid to the high potential side of the grid winding. The author shows skeleton circuits without d-c supplied to the plates, suggesting that a high impedance choke will serve to feed the d-c. For grid stabilization the capacity may be a stopping condenser, instead of a direct connection between grid and tuned circuit. Of this the author says, discussing a topic of which little explanation has been made, despite wide usage:

"This stopping condenser and the accompanying leak are advantageous inasmuch as it has been found by experience that an oscillator operating with a leak and condenser combination is inherently much more stable as regards change of frequency with change of battery voltage than an oscillator with a d-c low resistance path from grid to filament, even when a battery is employed to impose a negative bias on the grid.

Leak-Condenser in Oscillator

"The explanation for this improved stability lies in the fact that the grid leak tends to keep the grid resistance r_g constant. It frequently happens, when the leak and condenser combination is used, that difficulty is experienced in avoiding 'blocking' when a large enough condenser to have negligible reactance is employed." In such cases, he adds, the required value may be chosen and the circuit changed accordingly.

Mr. Llewellyn takes up also the feedback oscillator (tuned input circuit), as well as the reversed feedback oscillator (tuned output), and also the tuned plate-tuned grid with no magnetic coupling.

Both the filament voltage and the plate voltage were varied, but it was found that with the correct value of capacity for stabilization that the constancy was excellent, in respect to voltage, in fact, the only changes in frequency might be ascribed to the changes in temperature occasioned by the alteration in current. Stray voltages, such as those of harmonics, and other forces opposing stability, beside terminal voltages, while causing trouble, as in all oscillators, are correctible. He stresses the value of using grid leaks for reducing harmonic generation and shows how to select circuits that do not give certain troubles encountered in others.

What He Says of Dynatron

The paper is one of great interest and importance. The discussion is carried out on mathematical lines, with passing observations that clear up some points that do not usually find

ing Frequency of Oscillators

ol, Discussed in December "Proceedings"

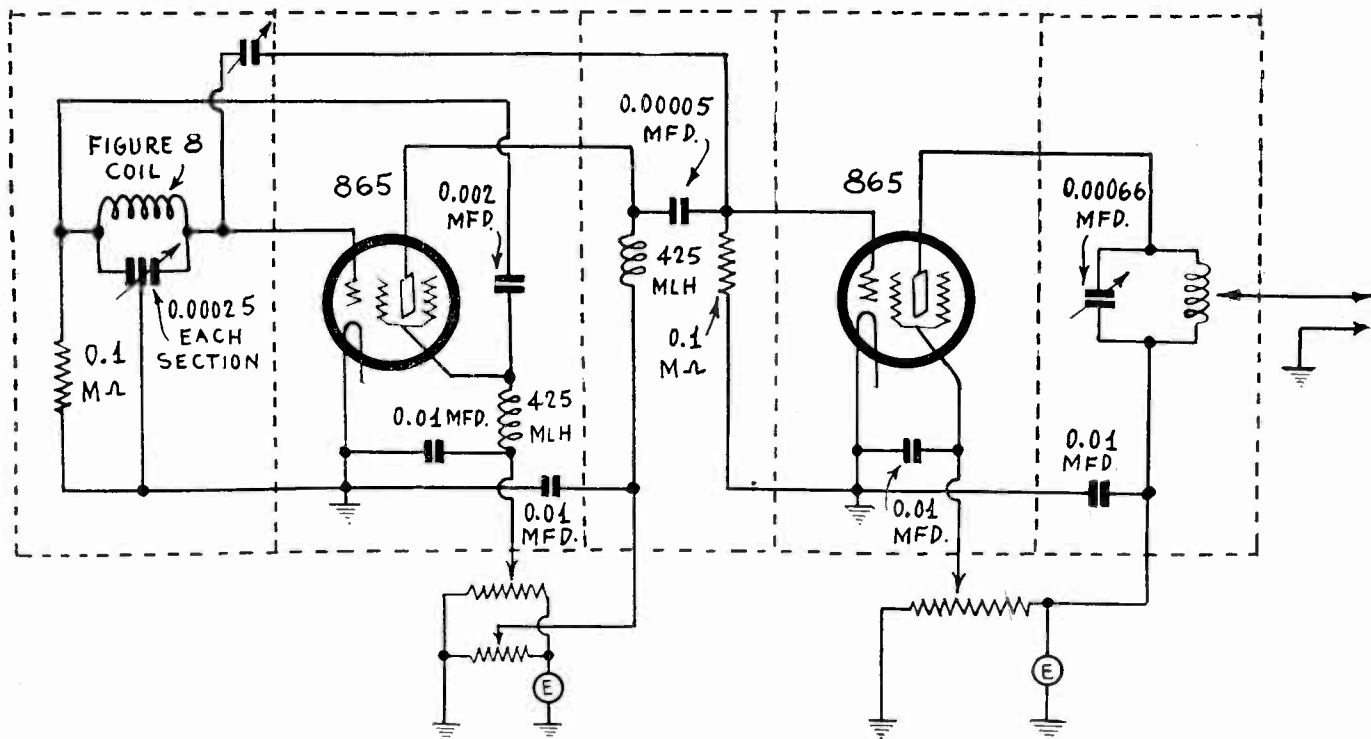

J. B. Dow attacks the same problem of frequency stability in oscillators, but in an entirely different and also original manner. His circuit is shown, with constants given. The potentiometer values are optional. E represents plate voltage batteries. The left hand shield compartment is a constant temperature oven. Two 865 tubes are used, but the 224 is practical also, if low output is sufficient.

their way into the pages of the "Proceedings." For instance, the very last paragraph of Mr. Llewellyn's article has this to say of the dynatron oscillator (which he does not include in his stabilized category):

"In the case of the dynatron type of oscillator, where the harmonic contents are especially strong, it has been found by experiment that the reactive component of the tube impedance can not be neglected, but that it is, in fact, altogether responsible for the variation in frequency with battery voltages which is characteristic of the dynatron oscillator."

Another paper, of paramount interest, and the result of many measurements taken with especial accuracy, is that of Mr. Dow, whose constant frequency oscillator uses a form of coupling he calls "electron," to protect the oscillator from being affected by the circuit it feeds. The tube used was of the two-plate type (865). Changes in generator voltage will have a negligible effect on frequency by compensation of the plate voltages.

transmitted to the work circuit in the sense that alternating electromotive forces may be transmitted from one circuit to another by capacities, inductive or direct coupling. As has been pointed out, any coupling of this nature has a deleterious effect and is purposely avoided to prevent reaction of the work circuit upon the frequency determining portion. The frequency determining portion of the circuit serves merely to control electron flow to the separate anode associated with the work circuit, thereby causing a pulsating direct current to flow in the work circuit impedance where an alternating electromotive force may be reincarnated at a frequency determined by the pulses of electrons which impinge upon that anode."

The author adds that, in the absence of a better term, it is convenient to refer to this form of coupling as electron coupling. The 865 was selected as the most suitable of common tubes, although the 224 could be used, he stated, being less microphonic but not being compensatable at high outputs.

Accurate to Fine Degree

The author set before himself the task of keeping the error, from whatever source caused, down to 15/1,000 of 1 per cent. Whenever capacitive, inductive or direct coupling was used between an oscillator and any terminal apparatus (fed or work circuit), frequency changes took place so long as the fed circuits derived any considerable amount of energy from the oscillator. Loose coupling would reduce the effect, but not sufficiently to come within the author's requirement.

"Other well known but less conventional forms of oscillator circuits, as those using the dynatron principle, were found to suffer from the influences of terminal apparatus quite as much as the more conventional types," said the author, thus making substantially the same assertion as Mr. Llewellyn.

After showing the development of the circuit by stages, the author stresses Fig. 4, which shows two UX-865 tubes, with associated apparatus, nothing complicated being at stake.

In connection with Fig. 4 he states:

"Study of the circuit will indicate that oscillations generated by the frequency determining portion of the circuit are not

Other Papers

C. K. Jen, a Chinaman, now associate in physics, Cruft Laboratory, Harvard University, contributes an article on "A New Treatment of Electron Tube Oscillators with Feedback Coupling." A carefully developed theory is presented, with some experimental corroboration, for the conditions that develop oscillation, a new expression being given for the ratio of the grid voltage to the plate voltage, defined in terms of excitation and phase difference. Mathematical expressions for various types of oscillators are given.

"Amplitude, Phase and Frequency Modulation," is discussed by Hans Roder, of General Electric Co., Schenectady, N. Y. "Application of Printing Telegraph to Long Wave Radio Circuits," by Austin Bailey and T. A. McCann, of the American Telephone and Telegraph Co., New York; "On Asymmetric Telegraphic Spectra," by C. R. Burch, of Metropolitan-Vickers Electrical Co., Ltd., Manchester, England, are the other technical papers in the December issue of "Proceedings," which also contains a report of the second meeting of the International Technical Consulting Committee on Radio Communication, Copenhagen, 1931.

A Question and Answer Department conducted by Radio World's Technical Staff. Only Questions sent in by University Club Members are answered. Answers printed herewith have been mailed to University Members.

Radio University

To obtain a membership in Radio World's University Club for one year, send \$6 for one year's subscription (52 issues of Radio World) and you will get a University number. Put this number at top of letter (not envelope) containing questions. Address, Radio World, 145 West 45th Street, New York, N. Y.

Annual subscriptions are accepted at \$6 for 52 numbers, with the privilege of obtaining answers to radio questions for the period of the subscription, but not if any other premium is obtained with the subscription.

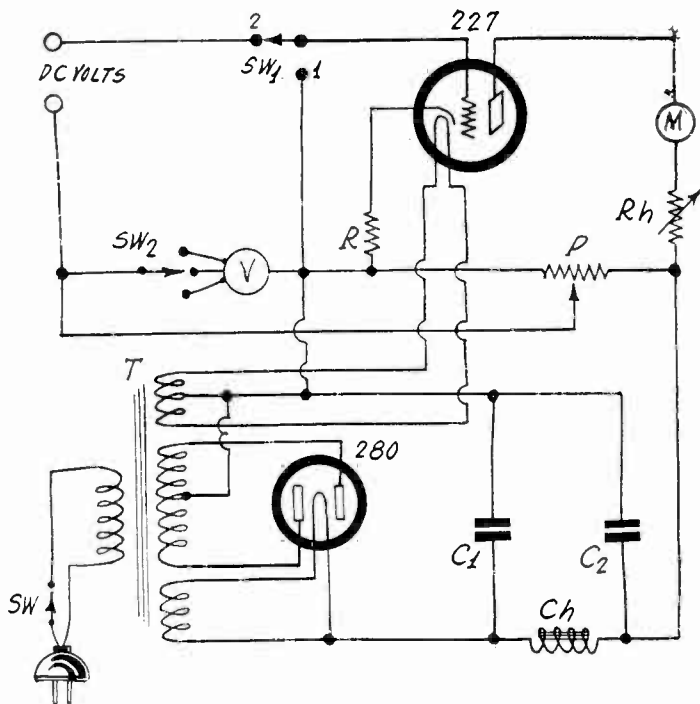

FIG. 978

An unknown voltage may be measured by this potential meter by the balancing process.

Potential Meter

COULD you recommend some simple, inexpensive method of measuring voltages accurately? I suppose that if real accuracy is to be attained, since so many voltages are across resistors that have little current through them, the measuring device itself should not draw any current from the measured circuit.—N. I. P., Milford, Donnegal, Ireland.

The direct current potential meter shown in Fig. 978 will serve the purpose excellently. In fact, it is a wonder that such a device as this is so seldom used. You will notice that there is a rectifier and that its voltage is applied to the plate of a 227 tube, in which circuit there is a current meter, M. The voltmeter is located in the measuring circuit that is closed when the measured circuit is included (across the terminals marked D-C Volts). The theory of operation is that the unknown voltage is measured by the bucking voltage of this device (see pointer of P), the known voltage being measured by the meter V as that in the left-hand portion of the potentiometer. The switch SW-1 is thrown to one position for balance, to establish a negative bias, not high enough of course to cut off plate current, but high enough to prevent flow of grid current. At position (1) there is no bias, and we read the meter M and note the reading. Rh can be used to make this reading an even number. Move the slider of P at or near the ground end, and pick up position (2). The plate current will drop. The slider can be moved to re-establish the current at what it was. Now the unknown voltage is equal to the reading on the meter V. For more complete details about this system see the October 31st issue of RADIO WORLD, which contained an article on the subject.

Substituted Parts for Midget

WOULD an aluminum chassis for the 5-tube midget, Blueprint No. 627, be as efficient as steel or change the value of any part? Also, could I use the Kelford transformer in this set? Also, I have a 0.00035 mfd. tuning condenser, three gang, but quite a bit longer than that specified for this set. Would this be all right for the above midget?—W. C. C., Santa Rose, Calif.

An aluminum chassis may be used just as well and does not require any change in parts. The Kelford transformer will serve this set. The high voltage winding is nearly right, if you use the 1,800 ohm tapped field coil dynamic, as specified. The three gang condenser you have will not fit into the chassis as diagrammed, because the two 8 mfd. wet electrolytics, mounted on top in inverted fashion, are in the way, but you could insert your own tuning condenser and instead use two dry electrolytics, mounted

against the rear flap, pointing toward the front flap, underneath. Be sure, however, to insulate the condenser next to the rectifier (B minus is not grounded).

Untapped Speaker Field

READING your October 24th issue, I see a circuit that I like very much. However, I have a speaker, but it does not have the tapped field coil, such as is called for, and I would like to know how I can use my present speaker. I am sending a hookup of a set and I would like to change the audio end so that I could separate the plate from the grid of the 245 tube.—J. W. Chicago, Ill.

Your speaker, from the diagram, has a field coil of 2,500 ohms, but no tap. You can use your speaker, but the plate voltage will be a little low. This is not serious. Connect two high resistances across the field coil, and put the grid return of the pentode to the joint. The resistance values are chosen on the basis of the measured or computed voltage drop in the field. The details were presented in a special article in last week's issue, taking up this very subject in detail, and giving the actual solution for some field coils, including 2,500 ohms. The method will work out all right in the hookup you sent.

Inductor Output Coupling

AS I have a Farrand inductor dynamic, do you suggest that I get a special output transformer to couple to a pentode, or how can the connection be arranged?—R. H. C., Cincinnati, O.

You can connect an audio choke of fairly high inductance, say 100 henries at 40 ma, from plate of the tube to B plus, and use a con- of 4 mfd. with one side to plate, other side to one speaker terminal, other speaker terminal to center of the pentode filament. Use two stages of audio at least.

Small Condensers Queried

AS to your issue of September 19th, 1931, page 14, will you please let me know how many plates in the variable condensers, 60 mmfd., 140 mmfd. an 250 mmfd., and also are all three of them of the midget type?—A. F. O., Girard, Pa.

The statement of capacity on the basis of number of plates is just a guess. The condensers you mention are of the midget type and are made by the Hammarlund Manufacturing Company, 424 West Thirty-third Street, New York City. Write to them for details on junior midlines. The rotors turn in a 2-inch diameter.

Wattage of Grid Leak

WILL a receiver grid leak of the 10,000 ohm type serve as a grid leak of 5 watts rating in a transmitter? How is the output rating of a tube determined?—P. W.

The grid leak you have is probably of the 1 watt rating, hence will not do. Usually the 5 watt type is two or three times as thick. The maximum undistorted power output is the basis of the rating and is determined at a stated load, as given by the tube manufacturer, on the basis of the standard test. If you are desirous of learning the standards, write to the Institute of Radio Engineers, 33 West 39th Street, New York, N. Y., for details of the Year Book that contained these data. They are to long to print here.

Push-Pull Circuit

REFERRING to audio regeneration, featured recently in your columns, I would like to know if it is practical to use two pentodes in push-pull, coupling from two stages of 227 resistance coupling, to get about 7.5 watts output. State how to couple the last stage transformer.—E. L. D., Sherbrooke, Quebec.

You may use a 0.1 meg. resistor in the plate circuit of the first 227 audio tube, with 10,000 ohm biasing resistor. Your second stage must be transformer coupled. Put no condenser across the biasing resistor. Use a grid leak of 0.5 meg., a push-pull input transformer with primary in the second 227 plate circuit, secondary connected with extremes to respective push-pull grids and center to grounded B minus. Use a 1,000 ohm biasing resistor. The bias for the pentodes would be obtained through a resistor of 200 ohms (5 watts rating), connected from filament center of the 2.5 volt pentode winding, or center of a center tapped resistor across this winding, to ground. No condenser should be across this resistor, either. Connect a resistor of 0.1 meg. from cathode of first audio to cathode of second audio. The output may be taken through a push-pull output transformer. You can get a dynamic speaker with a pentode push-pull output transformer built in, or use a speaker that has a center tapped magnet coil, center to B plus maximum, extremes or tipped leads to plates. The full voltage should be applied to the plate resistor, but only

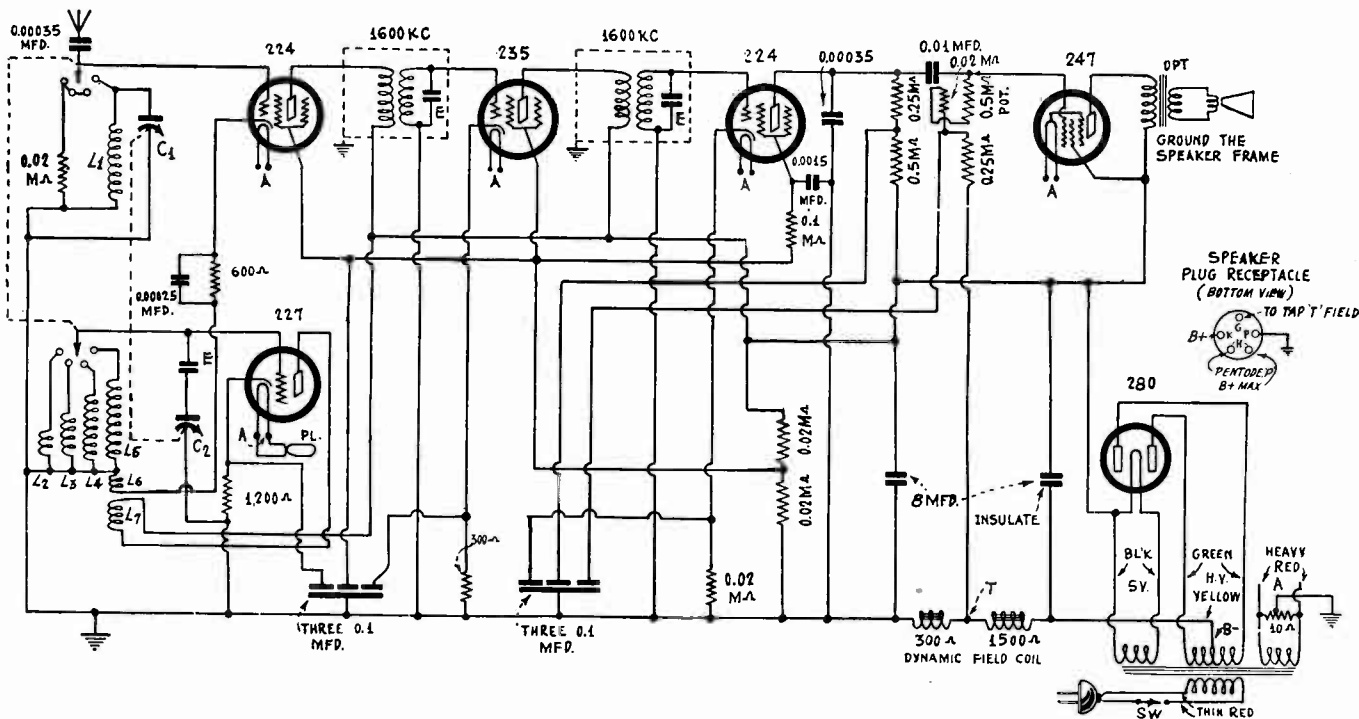

FIG. 979

Coil data for this circuit are given in answer to a question.

90 volts to the primary of the push-pull transformer, so that the current through its primary will not be too high, for high current drops the inductance severely, and stops low note reproduction.

Coils for 628-B

REGARDING the six-tube circuit, which I understand is Blueprint No. 629-B, will you kindly give me information on how to wind my own coils, as I have a coil winding machine, and I enjoy doing this work?—J. E., Mt. Vernon, N. Y.

The modulator circuit has a coil and a resistor, the oscillator circuit has coils only. The circuit may be used for 15-200 meter coverage, or, if desired, for that plus broadcast band coverage. It is assumed that you would like to cover the broadcast band, also. Therefore get a piece of tubing, any insulating material, 1 1/8 inch diameter, and for the broadcast modulator coil wind 120 turns of No. 31 wire, or use any size wire thereabouts. The resistor may be any value from 20,000 ohms up to 100,000 ohms or more, but not of the order of megohms. The oscillator coils may be wound on one tubing, 1 1/8 inch diameter. At extreme left the largest grid winding is located and consists of 50 turns of No. 28 enamel wire, tapped, then eight turns for pickup winding. Leave 1/8 inch space and wind 25 turns for the plate winding. The next winding consists of 30 turns, begun 1/4 inch away, the next, 1/4 inch away, of 15 turns, the next 1/4 inch away, of 7 turns. The windings are in the same direction, and the connections, left to right, are: oscillator grid, ground, (tap grounded), cathode of modulator, B plus, plate of oscillator, grid, ground, grid, ground, grid, ground. See Fig. 979 herewith.

Wants to Convert a Set

I HAVE a Stewart Warner radio, using four 226, one 227 and one 171 output tube. I want to convert this set into one using five 230 tubes and an output tube to be suggested. What I want is a stable DX set for use with a six-volt storage battery and a 36-inch Western Electric cone, both of which I have. Please give a diagram showing how to make these changes.—R. A., Clermont, Fla.

We advise against making the change, as it would be better to build a new set. Existing receivers are not very readily changed in a manner that improves them materially, even though newer tubes come out that one would like to put into an existing set. You can build a good set, using three stages of t-r-f, tuned detector, all four 232 tubes, first audio 231, push-pull 238 (pentode).

Resistor Smoked

HAVING built the 627 midget, using coils I wound according to your specifications, I found that when I inserted the 2,000 ohm resistor that was to drop the maximum B voltage to the plate voltage for the r-f tubes that the resistor got too hot and finally smoked. Also, the 224 tube goes up and down. I examined the set carefully and find no loose connection.—A. L., Philadelphia, Pa.

The reason the resistor got hot was that it wasn't of the 5 watt rating specified, but must have been a 1 watt or 1/2 watt resistor. However, you may omit this resistor entirely, if you like, and connect the maximum B plus lead to the plate returns of

the r-f tubes, using either 600 ohms for the limiting resistor in the volume control circuit (cathodes of first and second r-f), or preferably 400 ohms. The r-f coils have nothing to do with your trouble. The 224 tube that has an intermittent heater probably is quite all right, as the heat is steady, despite the flicker. Do not pay any attention to the flicker but only to the results actually obtained on your set, which should be excellent as soon as you have fixed up the plate feed to the r-f tubes.

Cure for Troubles in HB44

A WEEK ago I built your HB44 and will say that for volume it is unsurpassed, but that it is broad, so I have a band pass after built in. However, when turning up the volume to a high level the set goes into oscillation. When I first built the set I used grid leak detection. Since then I have changed over to power detection, using a 227 tube, the same as specified in an article by Manfred Kliest in your publication, one stage of transformer and two 245's in push-pull. Would introducing r-f chokes help? I get KFI, forty miles away, without any antenna.—W. F. P., Riverside, Calif.

The number of turns on the primaries of the interstage couplers is too large. You can safely cut down these primaries to almost half of the present number of turns. Be sure to connect a by-pass condenser of 1 mfd. or larger capacity from B plus r-f to grounded B minus. You may use r-f chokes of any reasonable inductance, 1 mfh. up, or 300 turn honeycomb coils, in the plate and screen leads, by-passed by 0.1 mfd. or higher capacity, but the reduction of primary turns will probably render this extra precaution unnecessary. Try also different values of detector biasing resistors, for instance, put 20,000 ohms across (in parallel with) the present detector biasing resistor. Stability is served when a long aerial is used, and after you have reduced the primary turns (except the antenna primary, which don't touch) you will be able to stand a long aerial and will have sufficient selectivity. Put a shield cover under the chassis, or just rest the chassis on a piece of aluminum a little larger than the bottom, to minimize stray pickup, such as reception of KFI without an aerial.

The Monitor Receiver

BEING constant readers of RADIO WORLD, we just were going through the October 31st issue in which we find the All-Wave Set, 10 to 2,000 meters, and is just the thing we are looking for. What we want to do is to build one of these for testing purposes, for business, as we don't mind number of controls, for we want results in the way of calibrating other receivers, short wave as well as long wave reception. We can build our own coils, etc., for which such a receiver would be a great help. Since this receiver has not been built by any one else, its performance is rather uncertain, and before we start building one of these, it specifies in the same article that you would be pleased to give further information on the results that you possibly by now have experienced. We presume the details have not been published in any of the issues since them unless it happens to appear in the next issue of which is not for sale yet. Since we are anxious to get started

(Continued on next page)

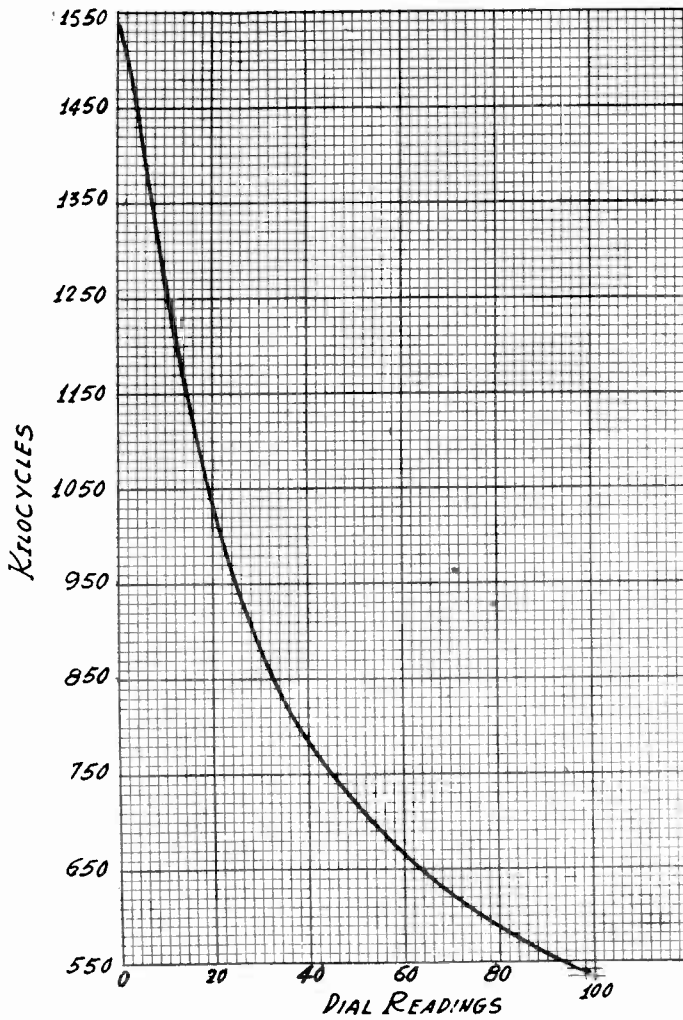

FIG. 980

How frequencies are plotted against dial readings.

(Continued from preceding page)

on one of these sets, we would appreciate a report on same as you have found it to operate, the voltages applied to the 235 tube in the detector circuit, plate and screen, is one of the details we

would like to know, as 235 tubes have not been used extensively in receivers for detection purposes.—C. H. B., Spokane, Wash.

Experimental work on this receiver is not completed. As you may know, the data on coverage of the broadcast band were published. Then, in an issue that intervened between the writing and receipt of your letter, another article was published, dealing with the first short wave band (December 5th Issue), but until the experimental work is completed we can not give you any further information. It is obvious the set needs vernier dials, and it is preferable that the tuning capacities be smaller than originally intended. The number of shields will be confined to the number of tuned circuits by having removable tops for permanent shield bases, so unshielded plug-in coils can be put into the sockets affixed to the metal bases, and the shield then put onto the bases as covers. The set performs well on the broadcast band. There is still trouble on the short wave band, but we expect to get rid of this and print the full data on the construction of this unique receiver. The December 5th diagram showed a 224 detector.

* * *

Grounding an Auto Set

AS a steady reader of RADIO WORLD I am glad to report that I have had wonderful results from all the hookups I have built from specifications printed in your magazine. I have just completed and installed the auto receiver designed by J. E. Anderson (covered by Blueprint No. 629) and the set performs very well, bringing in 16 stations, including four in Los Angeles and one in Salt Lake City, from a position 10 miles out of Oakland. When I installed the set I found A plus grounded on my Plymouth car, instead of A minus, and the only solution I could see was to insulate the set. I have no ground connection, as the set was built behind the instrument board. Will you please state how I can change the circuit to effectuate a ground for A minus?—S. J. S., San Leandro, Calif.

It is nice indeed to hear of your good results from the automobile receiver. You followed a diagram published prior to the announcement of the new tube (the 239, described in the December 12th issue) and the circuit lends itself to the insertion of two of these tubes in the r-f sockets, without any other changes. The newer blueprints include this specification. The new tube is a pentode r-f amplifier. The grounding of the circuit at A minus is so specified because it is assumed most cars have A minus of the storage battery grounded to the car frame, but if not, then A plus is grounded, and as your set picks up A plus, your set is sufficiently grounded. We would suggest, however, that the heaters be effectively removed from the tuned circuit by connecting a 1 mfd. condenser from A plus to A minus.

* * *

High Mu Wanted

I HAVE a Dayton Navigator Radio No. 71, the latest model they put out before discontinuing. This machine gave wonderful service with the Dayton tube, especially their 227 type, which I understand was a high mu type tube. I received very good service from other tubes which I understand are of somewhat higher amplification than the ordinary tubes. I am now using a third brand. I do not get the distance nor do I get the kick or wallop out of the machine that I did before with the other tubes. Can you recommend a 227 high mu type tube that will give the service that the machine was designed to give? I understand from some service men that I need a tube that is made for 2.7 volts instead of the regular tubes that are made for 2.5 V.—H. P. S., Birmingham, Ala.

There were a few high mu 227 tubes on the market, but so far as we know there are none now. That does not leave you up a tree, however, for with a slight change in your set you can get the results you had before. Disconnect the lead now going to grid of the 227 sockets, and instead bring it up through the chassis to a grid clip for a screen grid tube. Then connect with soldered wire the plate and screen (former grid) prongs of the socket. This changes the screen grid tube to a general purpose tube, and the mu is higher than that of the 227, which the converted tube otherwise resembles in performance. You may use any of the standard 224 or 324 tubes on the market for this purpose. Never mind the heater voltage distinction.

* * *

Plotting Frequency Versus Dial Settings

EVERY once in a while I see a curve of frequencies represented by dial settings, but I am not clear how I should go about making some curves on an all-wave tuner I have.—E.D.O., Walla Walla, Wash.

A piece of plotting paper is obtained. It may be ruled in squares, with heavy lines for large squares and lighter lines for the 100 squares within the large ones. If the extreme frequency (highest) that you tune in with a particular coil and condenser is written at left top, and the lowest at left bottom, with the dial settings recorded on the horizontal, in ascending order, left to right, you will get a curve something like that shown in Fig. 980, although the shape may be different. Plot a similar curve for each coil-condenser combination and you will have a permanent record you can consult in tuning for a particular frequency by schedule. The curve shown in that of a Hamarlund 0.0002 mfd. junior midline, and does not quite cover the broadcast band.

Join
Radio World's

University Club

And Get Free Question and Answer Service for the Coming 52 Weeks. This Service for University Subscribers Only. Subscribe for RADIO WORLD for one year (52 numbers). Use the coupon below or write on a separate sheet of paper, if preferred. Your name will be entered on our subscription and University Club lists by special number and you will be apprised of the number. When sending questions, put this number on the outside of the forwarding envelope (not the enclosed return envelope) and also put it at the head of your query. If already a subscriber, send \$6 for renewal from close of present subscription and your name will be entered in Radio University.

NO OTHER PREMIUM GIVEN WITH THIS OFFER

[In sending in your queries to the University Department please paragraph and number them. Write on one side of sheet only. Always give your University Club Number.]

RADIO WORLD, 145 West 45th Street, New York City. Enclosed find \$6.00 for RADIO WORLD for one year (52 nos.) and also enter my name on the list of members of RADIO WORLD'S UNIVERSITY CLUB, which gives me free answers to radio queries for 52 ensuing weeks, and send me my number indicating membership.

Name

Street

City and State.....

FREE-FOR-ALL AUDITIONS END; COST TOO MUCH

A long established institution of the broadcasting studios has been swept into oblivion. It is the system of unrestricted auditions which permitted anyone, regardless of previous experience or lack of any, to try for fame on the broadcasting networks.

The new system, recently inaugurated by the National Broadcasting Company, restricts auditions to persons with experience, training, or both, or persons supported by the indorsements of recognized authorities. Limited auditions, a system less altruistic than a wide open policy, is far more practical and will prove of greater benefit to artists and listeners alike, it is believed by Leslie Joy, N. B. C. auditions director.

Less Than 1 Per Cent. Reached Air

The revised procedure undoubtedly serves its purpose of increasing the department's efficiency, but at the same time it has eliminated one of the most interesting and colorful features of the studios, the heterogeneous crowds of waiting hopefuls, he said.

Heretofore many thousands of auditions have been granted monthly in the studios. Approximately three per cent. of the applicants passed the preliminary test but less than one out of every hundred actually got on the air. This percentage seemed too low to justify the great expense and time devoted to the quest of new material.

Written Applications

The system was based on the theory that the broadcasters should never overlook an opportunity to discover a new voice.

A careful study of the auditions records for several years revealed that all applicants who successfully passed the initial trial were persons with some training or experience. The exceptions were so few as to be negligible. The present system was then devised and put into effect.

The aspiring musician, whether vocalist or instrumentalist, must present his application in writing.

Cardwell Emphasizes Condenser's Importance

In a recent interview Allen D. Cardwell, pioneer condenser manufacturer, explained why high quality is of such great importance in variable condensers used in radio receivers and transmitters.

The variable condenser is one of the few parts of a radio set subjected to friction. Furthermore, since it furnishes the means of tuning in the various broadcast stations, it receives more mechanical usage than any other part of the receiver.

It is obvious, therefore, that the variable condenser, in addition to being perfect electrically, should be constructed to outlast all the other parts of the radio equipment. The properly designed condenser possesses a high degree of mechanical strength as well as high electrical efficiency. It is necessary for condenser plates to be absolutely rigid, not wobbly. Plate alignment must be perfect and permanent.

Cheer Leaders

Non-Exclusive

"I listened in last night and heard a crooner."

"Who didn't?" * * *

Mistaken Identity

Freudians think that an antennaplex is some sort of a radio complex.

Insight

If the radio comedians could only ascertain how many laughs they don't get for their funniest gags they'd get some idea of how unappreciative they think the radio audience is.

Newest Racket

Two men were debating the purchase of a radio set.

"I think it's a little too soon to buy a set," said the fellow who never had one. "I think I'll wait for television."

"I don't blame you," said the other, who had never thought of owning a set and who now heard of television for the first time. "I think I'll wait until the Federal Radio Commission grants that permit for a transmitter on Mars."

"Even that is reckless," observed the first one. "They're going to bring out some day a set that you take with you on your last journey, that enables you to talk to the friends you left behind. I'll get one of them, if it doesn't cost too much, and I can buy it on time."

"How will you pay for it after you're dead?" inquired the Mars-waiter.

"That's my racket." * * *

Comparative Nomenclature

First amateurs were given 300 meters to work on, then some one suggested that 175 meters would be the thing, and the amateurs stuck to 300 meters because there was nobody to tell them nay. Finally it developed great reception could be obtained at 175 meters. Then came 80 meters, 40 meters, then 20 meters. Now televisionists are trying ultra frequencies, fractions of a meter, and soon they'll be sending out voice and pictures on fractions of a light wave and calling it low frequency transmission.

Too Much to Study

Now they bring out a new tube before a fellow has had half a chance to learn the numbers and characteristics of the old ones.

The Precious Audience

If all the ancient sets could be thrown in the river, what would be left for listening to the most expensive programs?

Couldn't Stand Liking Life

Some persons make a great deal out of nothing, while others never listen in for fear that life will turn out to be surprisingly enjoyable.

Imitators

Beards worn by clean-shaven men who appear before televisions simply prove that when a foreign notable like Dino Grandi comes over here he has no end of imitators.

Safety

If only one person can look at a television frame at a time, there will be less jealousy in the household when husband eyes up the television girl.

NEW TELEVISED PICTURE HAILED AS PERFECTION

The National Broadcasting Company will be on the air with television soon.

Don E. Gilman, vice president in charge of the Pacific Division of the National Broadcasting Company, made the announcement in New York.

The Western N.B.C. executive visited the new television studios which are almost completed on the top floor of the Empire State Building, from where television broadcasts will be made on regular schedules shortly, he said.

"The demonstration I saw there was beyond anything I have ever witnessed," Mr. Gilman explained. "You get a perfect picture, with no distortion such as was unavoidable up to a few months ago. Even seen from one side, the picture remains clear. Television has made two years' progress in six months, and still is going so fast that it is difficult to make predictions.

Calls It Achievement

"The installation in the Empire State Building, which will be complete within a very short time, is a remarkable scientific achievement, yet the engineers expect that television will develop so rapidly that the present equipment will be obsolete within six weeks after the first broadcasts are made."

It will be at least a year after the New York broadcasts begin before the Pacific Division will be on the air with television, Mr. Gilman said. Development of television in the West will be governed largely by the activities in the East.

Horizon Range

"Television is going to be restricted by the horizon to a degree which many enthusiasts refuse to recognize," he declared. "Ultra-frequency waves, unlike those of broadcasting, will be used. They penetrate buildings, but mountains are an insurmountable obstacle to such a television broadcast. The television picture cannot be transmitted by wire, like a radio broadcast, so television studios necessarily must be located on the highest point in the area it is desirous to reach.

"In the San Francisco region, I estimate we shall be able to reach three-quarters of the population with television."

Spangler in Tube Post Vacated by Williams

National Carbon Company, Inc., has announced the appointment of J. M. Spangler as manager of its Eveready Raytheon tube division, succeeding Fred D. Williams, who recently resigned to become an officer of P. R. Mallory & Co., New York City. Mr. Spangler's appointment follows sixteen years connection with the company.

Prior to taking over his new duties in the tube division he was manager of the Eastern division of his company, a position he has held several years. His services with National Carbon Company began in 1915 as railroad sales engineer. In 1918 he organized the railroad department, in which he served as manager until 1923, when he was appointed manager of the company's Central division.

A THOUGHT FOR THE WEEK

WHY do so many of the smaller stations seem to make a point of sending out on Sundays the poorest, cheapest, most exasperatingly flopdoodle announcements of the whole week? Can't something be done about it? Let's put on our thinking caps and try to work out a way to stop this weekly batch of harm to the good name of radio!

RADIO WORLD

The First and Only National Radio Weekly
Tenth Year

Owned and published by Hennessy Radio Publications Corporation, 145 West 45th Street, New York, N. Y. Roland Burke Hennessy, president and treasurer, 145 West 45th Street, New York, N. Y.; M. B. Hennessy, vice-president, 145 West 45th Street, New York, N. Y.; Herman Bernard, secretary, 145 West 45th Street, New York, N. Y. Roland Burke Hennessy, editor; Herman Bernard, managing editor and business manager; J. E. Anderson, technical editor; J. Murray Barron, advertising manager.

Dynatron Oscillator

MUCH affection for the dynatron oscillator, based on stability of frequency, apparently has been undeservedly bestowed, for the dynatron now appears as a device subject not only to frequency variations but as over-rich in harmonics. Two contributors to the December issue of "Proceedings of the Institute of Radio Engineers" happen to remark upon the same thing, substantially, in respect to the dynatron.

Says F. B. Llewellyn, of the Bell Telephone Laboratories:

"In the case of the dynatron type of oscillator, where the harmonic contents are especially strong, it has been found by experiment that the reactive component of the tube impedance can not be neglected, but that it is, in fact, altogether responsible for the variations in frequency with battery voltages which is characteristic of the dynatron oscillator."

In presenting stabilizing systems applicable to standard oscillators, his own contribution to the advance of accuracy in oscillators, the author does not include the dynatron, and the reason is obvious from his remarks on the subject of that type of oscillator.

Says J. B. Dow, Bureau of Engineering, Navy Department:

"Other well known but less conventional forms of oscillator circuits, as those using the dynatron principle, were found to suffer from the influence of terminal apparatus quite as much as the more conventional types."

The change in battery voltage, therefore, is considered by these two experts as being strongly effective on the frequency of oscillation, and as such effect is exactly the contrary to stability, what is there left of the much-vaunted frequency stability of the dynatron?

There are commercial dynatron oscillators, as well as many constructed by experimenters for their own use, and the assumption was that the frequency stability was better than that of some other types. Perhaps the only thing amiss is that the accuracy did exist when the voltages were exactly the same at all measurements, but when different voltages are purposely applied, the frequency difference shows up. Or, the word "accuracy" holds for errors up to 1 per cent.

Since voltage differences are bound to arise, if for no other reason than the normal change in apparent voltage from the batteries, all oscillator systems that pretend to accuracy evidently will have to be subjected to a stabilizing influence,

and the methods presented by the two authors are very promising.

Especially does Mr. Llewellyn hit a high mark, for he found that with his system the frequency changes, where they did creep in, were not due to voltage changes, once the circuit was stabilized against frequency change due to voltage differences, but that mechanical and temperature conditions could account for the sole frequency changes suffered. He used capacity for stabilization, and one of the lines of his curves was perfectly flat, that is, there was no frequency change, though the steady frequency of oscillation was 10,000,000 cycles.

Mr. Dow held himself to a different goal, fixing a maximum error not exceeding 0.015 per cent, and worked out a practical and not difficult circuit. He paid especial attention to the frequency-changing effect of the external load, or circuit coupled to the oscillator, as this is a serious drawback in all systems. So he developed what he calls electron coupling, devoid of capacitive, inductive or direct coupling, the unison being solely by the electronic stream.

Both authors, and engineers generally, respect the importance of a high degree of accuracy in oscillators, not only of the fixed frequency type, where crystal control, with thermostatic adjunct, would solve the problem, but for variety tuning, where no crystal is used. Due to the expense of crystal, holder and thermostat, the cost becomes prohibitive, possibly running into hundreds of dollars, while there is great need for a multi-frequency stable oscillator within the means of the average radio worker. Therefore the work of these two men in developing systems dispensing with crystal controls is of high importance, and their contribution to the art should prove valuable.

In one of the articles passing mention is made of a high ratio of capacity to inductance to assist in frequency stability, with the admission of reduction in output power, or the restriction to taking off only small power, but in connection with the dynatron oscillator it has been found that the inductance to capacity ratio should be high, otherwise there is danger of stoppage of oscillation. A typical oscillator, with 0.00035 mfd. tuning condenser, with tuning begun at 600 meters, stopped oscillating at about 70 meters. This point was registered in an article entitled "Some Shortcomings of All-Wave Dynatron Oscillators," by J. E. Anderson, in the October 24th (1931) issue of RADIO WORLD.

So the dynatron has much to answer for, and perhaps we are to see the birth of a new standard oscillator of high accuracy, which may be one of the types discussed by the two authors in the December "Proceedings," whereby the radio experimenter also will get the type of service he desires. If, at a little more trouble or expense, he can obtain an oscillator that is accurate enough for monitoring a transmitter, he certainly will want such for the laboratory.

Radio Tax Opposed

WHILE at first it seemed that the radio trade would take a tolerant attitude on a tax on radio sets, due to the state of the Government's finances, now the trade has come forward in opposition to such a tax, because it would be a luxury tax, and sets would be classified as luxuries.

The definition of luxury is a matter of law, or a mixed question of law and of fact, yet it is to be expected that all associated with radio, as well as all radio users, will regard a set as no luxury. If one defines as a luxury anything that one can live without, then everything is a luxury except possibly food, clothing and shelter. And much food is luxurious, as are many fine wraps and lordly mansions.

One might apply the dictionary test. It is quite proper, even in arriving at legal

determination, to consult the dictionary as to the meaning of a word. The definition may not be controlling, but it is at least indicative. Therefore, after definitions outlawed because archaic, we come to this one:

"A free indulgence in costly food, dress, furniture, or anything expensive that gratifies the appetites or tastes; also a mode of life characterized by material abundance and gratification of expensive tastes."

It can be seen that the idea of expense has something to do with luxury. The word also had an early association with lust.

So any one who desires to appraise radio as a necessity or a luxury will get a great deal of assistance from the dictionary, and may compare the definition thus obtained with the prevailing prices of sets, parts and accessories, and determine whether "expensive" really applies.

KALEIDOSCOPE

Television signals travel via air and ground. The signal with the greater stamina is the ether carrier. Engineers are unflattering to the ground conductor. Anyway the low-down wave is often a dependable alternative when the air rival gets a loggy headache.

* * *

A metal umbrella overhead the aerial runs ghosts down to earth—referring, of course, to those inherited from television transmission.

* * *

Harvard-Oxford air debate will be remembered as an affair where the unseen audience was admitted with informal dress. —A. B.

ANSWERS TO CORRESPONDENTS

H. VICTOR CATE, SYRACUSE, N. Y.: Bradford Browne and his partner, Al Lewellyn, are off the air at present. They expect to become connected with a station in the near future. Shall notify you.

* * *

PEARL ROSKAM, BALTIMORE, MD.: You may purchase the Street Singer's record of his theme song, "Marta," from any phonograph store, or direct from the maker, Brunswick Recording Co., 799 Seventh Ave., New York.

* * *

H. VICTOR GATES, SYRACUSE, N. Y. . . . You may now hear Bradford Browne as the Master of Ceremonies on the Three Bakers program over WJZ, every Sunday at 7:30 p.m.

* * *

J. PRINGLE, BOSTON, MASS. . . . Yes, quite a few women crooners are heavy. Mildred Bailey, Kate Smith, Vaughn de Leath and Tess Gardella are all on the heavy side. On the other side you can list Welcome Lewis, Audrey Marsh, Marion Harris, Lee Morse, Alice Remsen, Irene Beasley, Alice Joy and several others, who are all slender.

Sundry Suggestions for Week Commencing December 20

Sun., Dec. 20: The Silver Flute...WEAF 1:30 p.m.
Sun., Dec. 20: Footlight Echoes...WOR 10:30 p.m.
Mon., Dec. 21: Pat Barnes, in Person
WJZ 12:15 p.m.
Mon., Dec. 21: Singin' Sam.....WABC 8:15 p.m.
Tues., Dec. 22: Voice of Firestone
WEAF 8:30 p.m.
Tues., Dec. 22: Nocturne, Ann Leaf
WABC 11:45 p.m.
Wed., Dec. 23: Kathryn Parsons...WABC 3:00 p.m.
Wed., Dec. 23: Rameses Program...WJZ 6:15 p.m.
Thurs., Dec. 24: Carl Fenton & Bing Crosby
WABC 7:15 p.m.
Thurs., Dec. 24: The Weaver of Dreams
WOR 10:15 p.m.
Fri., Dec. 25: Twilight Voices.....WEAF 4:15 p.m.
Fri., Dec. 25: Paul Whiteman & Mildred Bailey
WJZ 10:00 p.m.
Sat., Dec. 26: Mr. Bones and Company
WEAF 6:45 p.m.
Sat., Dec. 26: Little Symphony Orchestra
WOR 8:00 p.m.

Station Sparks

By Alice Remsen

Spirit of the Southland

(For Aunt Jemima, WABC)

Daily except Sunday 2:00 p. m.

THE spirit of the Southland is calling me back home,
I can even hear the humming of bees 'round the comb,
I can hear a sweet bird singing, and the ring dove's plaintive call,
Where the jasmine vine is clinging to the dear old homestead wall.
I can feel the cool, dark forest where the dusky cypress plume
Is waving in the breezes, and 'the wild vine tendrils bloom.
Oh, my heart is filled with longing as 'round the world I roam;
The spirit of the Southland is calling me back home.

—A. R.

* * *

And Aunt Jemima Certainly Can Take You Way Down South with her Southern blues singing on the Jad Salts program over WABC. Aunt Jemima's right name is Tess Gardella. She is a hefty lass with a comely face and hearty smile. She has lost sixty pounds in the last couple of months, but still has enough avoirdupois to last for a while. Tess is American born and bred of Italian parentage and has had many interesting experiences during her professional career, some of which I shall incorporate in a biography in one of our forthcoming issues.

* * *

And So The Mills Brothers Have Their Commercial. They deserve it for they are unique. It took them only two months of intensive broadcasting to achieve the enviable position of one of the most discussed features on the air today; to become a first-class theatre attraction; to rate as a drawing card for a night club, and to sell their wares for a tidy sum to a commercial sponsor. Of course, the Columbia Broadcasting System deserves a whole lot of credit for the way in which it handles and exploits its radio material.

* * *

Another Good Bet For a Commercial Sponsor should be Arthur Tracy, "The Street Singer," also "spotted" by Columbia. Kathryn Parsons would be great for a morning or afternoon commercial. Why is it that Ben Alley with his lovely voice has not been exploited and sold? Is it a matter of personal interest or lack of personality? It seems to me with proper handling he should be on a par with more than one high-priced tenor.

* * *

Paul Whiteman will leave the N. B. C. Chicago studios early in January for a five week tour of R-K-O theatres. His first

stop will be St. Louis, Jan. 8th. Mildred Bailey and Jack Fulton, Jr., will be with him. The Whiteman group, which includes his orchestra, will also play in Cincinnati, Chicago, Detroit and Cleveland, returning to the Edgewater Beach Hotel late in the Spring.

* * *

The Sistine Choir, singing in Rome, will be heard in this country on Christmas Eve over an N.B.C.-WEAF network at 9:30 p.m. EST. This broadcast has been arranged by the sponsors of "Adventures of Sherlock Holmes" and will be heard during the period usually taken by that detective series.

* * *

The Major Bowes Family broadcast, from the Capitol Theatre, New York, has been changed from Friday back to its old day, Sunday, when it may now be heard at 11:30 a.m. all over the country.

* * *

Russ Columbo has been engaged to direct his own orchestra in the Empire Room of the Hotel Waldorf-Astoria. He will lead the orchestra, play the violin and be Master of Ceremonies during the supper hour six nights a week. This will not interfere with his nightly broadcasting schedule.

* * *

Ray Perkins also has his commercial, which is very good news, for Ray is a clever boy and well worth a listen. In fact, he is on two sponsored programs: Thursday and Friday morning at 10:00 over WJZ, as the Prince of Pineapple, and Tuesday and Saturday at 6:30 p.m. over WJZ as The Old Topper.

* * *

Ralph Kirbery, who graduated to N.B.C. a short time ago, is now being featured nightly, except Sunday and Monday, as "The Dream Singer" over WEAF, in a five-minute recital. Just as the clock strikes midnight, Ralph will start singing a short group of popular and semi-classical ballads. It seems a shame to waste good material like Ralph Kirbery in such a short broadcast. It hardly gives him time to give even one number full justice, and just as the air audience is becoming used to his delightful voice, they lose him.

* * *

Frank Munn lost his own identity for four years in that of Paul Oliver, for the Palm Olive Hour. Now Frank is himself again, since Palmolive leaves the airwaves, and we may expect to hear his fine tenor voice floating through our loud speakers more frequently.

* * *

Gene Rodemich's retort to a friend is priceless. Lamented the friend: "Gee, I have no luck with women." Retorted Gene: "Lucky fellow!"

SIDELIGHTS

LEONARD JOY, musical director for N.B.C., started his musical career at the piano. . . . MOLLIE GIBBONS, N.B.C. fashion expert, is well known on the London stage. . . . BOB RIPLEY, of "Believe it or Not" fame, was once the handball champion of New York; he also tried out as pitcher for the New York Giants. . . . MAY SINGHI BREEN, the N.B.C. Ukulele Lady, got her first ukulele as a Christmas present. . . . HELENE HAN-DIN, N.B.C. actress of "The Two Trouper's" fame, earned her first five dollars singing with a band in Salt Lake City. . . . LUDWIG LAURIER, N.B.C. conductor, once mixed pills and powders in a drug store to earn money for violin and music study. . . . W. H. SAMS, well-known legitimate actor, now heard as the father on WEAF'S "True Story" hour, is very fond of cats. He owns four of them. . . . FREDDIE RICH, of WABC, once played piano in an East Side nickelodeon. . . . BEN BERNIE once demonstrated fiddles in a New York department store. . . . MORTON DOWNEY was once fired from a job in an installment furniture store. . . . GEORGE HALL once directed the orchestra for Fritzi Scheff at the old Palais Royale in New York.

Biographical Brevities

A FEW FACTS ABOUT LOTTICE HOWELL

Lottice Howell, now presenting a series of song recitals over an NBC-WEAF network, is a belle of the Sunny South. She was born in Kentucky, but spent most of her early life in Birmingham, Ala. Her southern manners and feminine charm won her acclaim in London recently when she played at the Palladium and Holborn Empire.

Eyes on New York

Although Miss Howell won a degree in music from the Women's College of Alabama, her ambition was to reach New York, but she had to wait until she had saved enough money from her salary as a church soloist to finance herself. Then she tucked her music roll under her arm and attacked the metropolis. Behind the fragile cameo-like beauty of Lottice Howell is real courage. Her first engagement was at the Strand Theatre, where she told Mr. Plunkett, the program director, that she'd had lots of experience; she got by with it, too. Then she toured with the Hanshaw Opera Company, and later joined the Roxy Gang. Then followed engagements in "The Music Box Revue," "My Maryland" and "Deep River."

Miss Howell has no wish to be a motion picture star. She appeared with Ramon Navarro in "Gay Madrid," but was cast in a vampire role. To look at her straight, black hair parted in the middle, almond-shaped eyes, and her appealing oval face, it is easy to understand why she didn't enjoy being a villainess of the screen.

Gown She Admires

Clothes are the singer's hobby—the kind of clothes that fit personality. In particular she admires the dainty old-fashioned gown fitting tightly at the waist line, but with plenty of "curtseying" room in the skirt.

Miss Howell is fond of sports, especially football and baseball. She's a boxing fan, too, though you wouldn't think it to look at her.

* * *

[If you care to know something of your favorite radio artists and announcers, drop a card to the conductor of this page. Address her, Miss Alice Remsen, c/o RADIO WORLD, 145 West 45th St., New York, N. Y.]

COMIC CUTS

Mark Warnow, Columbia orchestra leader, listened to an audition in which several sopranos exercised their vocal chords. As he emerged from the studio he was asked: "How did the singers rank?" "They didn't," replied Mark, "They were!"

* * *

Lois Bennet of WOR, was being fitted to a pair of those reptile skin shoes. From the next aisle came this: "I'm afraid these Louis XV heels are too low. Perhaps you have some higher, say Louis XVII or Louis XVIII."

* * *

Carl Fenton tells one about the couple inhaling chowder. Said she: "Seems to me we don't hear so much jazz in the restaurants now-a-days." Answered he: "No, and as a consequence we hear more soup."

U. S. Broadcast Stations by Frequencies

(550 to 1040 kc, corrected up to December 10th, 1931)

550 KILOCYCLES—545.1 Meters

Call letters	Main studio location	Licensor	Power	Time of operation
WGR	Buffalo, N. Y.	T—Amherst, N.Y. Buffalo Broadcasting Corporation	1KW	Unlimited.
WKRC	Cincinnati, Ohio	WKRC (Inc.)	1KW	Do.
KFUO	St. Louis, Mo.	Evangelical Lutheran Synod of Missouri, Ohio, and other States, Rev. R. Kretzschmar, chair man of Control of Concordia Seminary	500W	Shares With KSD.
KSD	St. Louis, Mo.	Pulitzer Publishing Co.	500W	Shares with KFYO.
KFDY	Brookings, S. Dak.	South Dakota State College	{ 500 W 1KW—LS }	Shares with KFYO.
KFYR	Bismarck, N. Dak.	Meyer Broadcasting Co.	1KW	Shares with KFDY.
KOAC	Corvallis, Oreg.	Oregon State Agricultural College	2½KW—LS 1KW	Unlimited.

560 KILOCYCLES—534.4 Meters

WLIT	Philadelphia, Pa.	Lit Bros.	500W	Shares with WFL
WFL	Do.	Strawbridge & Clothier	500W	Shares with WLIT.
WQAM	Miami, Fla.	Miami Broadcasting Co.	1KW	Unlimited.
KFDM	Beaumont, Tex.	Magnolia Petroleum Co.	{ 500W 1KW—LS }	Do.
WNOX	Knoxville, Tenn.	WNOX, Inc.	{ 1KW 2KW—LS }	Do.
WIBO	Chicago, Ill.	T—Des Plaines, Ill. Nelson Bros. Bond & Mortgage Co.	1KW	Shares with WPCC and WISJ.*
WPCC	Chicago, Ill.	North Shore Church	1½KW—LS	Shares with WIBO and WISJ.*
KLZ	Denver, Colo.	Reynolds Radio Co. (Inc.)	500W	Shares with WIBO and WISJ.*
KTAB	San Francisco, Calif.	T—Oakland The Associated Broadcasters (Inc.)	1KW	Unlimited.

570 KILOCYCLES—526.0 Meters

WNYC	New York, N. Y.	City of New York, Department of Plant and Structures	500W	Shares with WMCA.
WMCA	New York, N. Y.	T—Hoboken, N. J. Knickerbocker Broadcasting Co. (Inc.)	500W	Shares with WNYC.
WSYR-WMAC	Syracuse, N. Y.	Clive B. Meredith	250W	Unlimited.
WKBN	Youngstown, Ohio	WKBN Broadcasting Corp.	500W	Shares with WEAO.
WEAO	Columbus, Ohio	Ohio State University	750W	Shares with WKBN.
WWNC	Asheville, N. C.	Citizen Broadcasting Co.	1KW	Unlimited.
KGKO	Wichita Falls, Tex.	Wichita Falls Broadcasting Co, Inc.	{ 250W 500W—LS }	Do.
WNAX	Yankton, S. Dak.	The House of Gurney (Inc.)	1KW	Do.
KXA	Seattle, Wash.	American Radio Telephone Co.	500W	Do.
KMTR	Los Angeles, Calif.	KMTR Radio Corporation	500W	Do.

580 KILOCYCLES (Canadian Shared)—516.9 Meters

WTAG	Worcester, Mass.	Worcester Telegram Publishing Co. (Inc.)	250W	Unlimited.
WOBU	Charleston, W. Va.	WOBU (Inc.)	250W	Shares with WSAZ.
WSAZ	Huntington, W. Va.	WSAZ (Inc.)	250W	Shares with WOBU.
KGFX	Pierre, S. Dak.	Dana McNeil	200W	Daytime.
WIBW	Topeka, Kans.	Topeka Broadcasting Association (Inc.)	1KW*	Shares with KSAC.
KSAC	Manhattan, Kans.	Kansas State Agricultural College	{ 500W 1KW—LS }	Shares with WIBW.

590 KILOCYCLES—508.2 Meters

WEEL	Boston, Mass.	T—Weymouth, Mass. Edison Electric Illuminating Co. of Boston	1KW	Unlimited.
WKZO	Berrien Springs, Mich.	WKZO (Inc.)	1KW	Daytime.
WCAJ	Lincoln, Nebr.	Nebraska Wesleyan University	500W*	Shares with WOW.
WOW	Omaha, Nebr.	Woodman of the World Life Insurance Association	1KW	Shares with WCAJ.
KHQ	Spokane, Wash.	Louis Wasmer (Inc.)	{ 1KW 2KW—LS }	Unlimited.

600 KILOCYCLES (Canadian Shared)—499.7 Meters

WICC	Bridgeport, Conn.	T—Easton, Bridgeport Broadcasting Station (Inc.)	250W	Shares with WCAC
WCAC	Storrs, Conn.	Connecticut Agricultural Colls.	250W	Shares with WGBS.
WCAO	Baltimore, Md.	Monumental Radio (Inc.)	250W	Unlimited.
WREC	Memphis, Tenn.	T—Whitehaven, Tenn. WREC (Inc.)	{ 500W 1KW—LS }	Unlimited.
WMT	Waterloo, Iowa	Waterloo Broadcasting Co.	500W	Do.
KFSD	San Diego, Calif.	Airfan Radio Corporation (Ltd.)	{ 500W 1KW—LS }	Do.

610 KILOCYCLES—491.5 Meters

WTAY	Cleveland, Ohio	Cleveland Radio Broadcasting Corporation	500W	Daytime.
WIP	Philadelphia, Pa.	Gimbel Brothers (Inc.)	500W	Shares with WFAN.
WDAF	Kansas City, Mo.	Kansas City Star Co.	1KW	Unlimited.
KFRC	San Francisco, Calif.	Don Lee (Inc.)	1KW	Do.
WFAN	Philadelphia, Pa.	Keystone Broadcasting Co.	500W	Do.

620 KILOCYCLES—483.6 Meters

WLBZ	Bangor, Me.	Maine Broadcasting Co. (Inc.)	500W	Unlimited.
WFLA-WSUN	Clearwater, Fla.	{ Clearwater Chamber of Commerce and St. Petersburg Chamber of Commerce }	{ 1KW 2½KW—LS }	Do.
WTMJ	Milwaukee, Wis.	T—Brookfield, Wis. The Journal Co. (Milwaukee Journal)	{ 1KW 2½KW—LS }	Do.
KGW	Portland, Oreg.	Oregonian Publishing Co.	1KW	Do.
KTAR	Phoenix, Ariz.	KTAR Broadcasting Co.	{ 500W 1KW—LS }	Do.

630 KILOCYCLES (Canadian Shared)—475.9 Meters

WMAL	Washington, D. C.	M. A. Leese	{ 250W 500W—LS }	Unlimited.
WOS	Jefferson City, Mo.	Missouri State Marketing Bureau	500W	Shares with WGBF and KFRU.
KFRU	Columbia, Mo.	Stephens College	500W	Shares with WOS and WGBF.
WGBF	Evansville, Ind.	Evansville on the Air (Inc.)	500W	Shares with WOS and KFRU.

640 KILOCYCLES—468.5 Meters

WAIU	Columbus, Ohio	Associated Radiocasting Corp.	500W	Limited.
WOL	Ames, Iowa	Iowa State College of Agriculture and Mechanic Arts.	5KW	Daytime.
KFI	Los Angeles, Calif.*	Earle C. Anthony (Inc.)	50KW	Unlimited.

650 KILOCYCLES—461.3 Meters

WSM	Nashville, Tenn.	National Life & Accident Insurance Co.	5KW	Unlimited.
KPCB	Seattle, Wash.	Queen City Broadcasting Co.	100W	Limited.

660 KILOCYCLES (Canadian Shared)—454.3 Meters

WEAF	New York, N. Y.	T—Bellmore, N. Y. National Broadcasting Co. (Inc.)	50KW-LP	Unlimited.
WTIC	Hartford, Conn.	Travelers Broadcasting Serv., Inc.	5KW	Do.
WAAW	Omaha, Nebr.	Omaha Grain Exchange	500W	Daytime.

670 KILOCYCLES—447.5 Meters

WMAQ	Chicago, Ill.	T—Addison, Ill. WMAQ (Inc.)	5KW	Unlimited.
------	---------------	-----------------------------	-----	------------

* Experimentally.
 * WISJ temporarily operating on 780 kilocycles.
 * Experimentally.
 * C. P. to decrease power to 250 watts.
 * C. P. to move transmitter to Buena Park and increase power to 50 KW-LP.

BROADCASTING STATIONS BY FREQUENCIES—Continued

680 KILOCYCLES—440.9 Meters

Call letters	Main studio location	Licensee	Power	Time of operation
WPTF	Raleigh, N. C.	Durham Life Insurance Co.	1KW	Limited.
KFEQ	St. Joseph, Mo.	Scroggin & Co. Bank	2½KW	Daytime.
KPO	San Francisco, Calif.	Hale Bros. Stores (Inc.), and the Chronicle Publishing Co.	5KW	Unlimited.

690 KILOCYCLES (Canadian Exclusive)—434.5 Meters

WLW	Cincinnati, O.	T—Mason, Ohio. Crosley Radio Corporation	50KW-LP	Unlimited.
-----	----------------	--	---------	------------

710 KILOCYCLES—422.3 Meters

WOR	Newark, N. J.	T—Kearny, N. J. Bamberger Broadcasting Service (Inc.)	5KW	Unlimited.
KMPC	Los Angeles, Calif.	R. S. MacMillan	500W	Limited.

720 KILOCYCLES—416.4 Meters

WGN—WLIB	Chicago, Ill.	T—Elgin, Ill. The Tribune Co.	25KW	Unlimited.
----------	---------------	-------------------------------	------	------------

730 KILOCYCLES (Canadian Exclusive)—410.7 Meters

740 KILOCYCLES—405.2 Meters

WSB	Atlanta, Ga.	Atlanta Journal Co.	5KW	Unlimited.
KMMJ	Clay Center, Nebr.	The M. M. Johnson Co.	1KW	Limited.

750 KILOCYCLES—399.8 Meters

WJR	Detroit, Mich.	T—Sylvan Lake Village, Mich. WJR, The Goodwill Station (Inc.)	5KW	Unlimited.
-----	----------------	---	-----	------------

760 KILOCYCLES—394.5 Meters

WJZ	New York, N. Y.	T—Bound Brook, N. J. National Broadcasting Co. (Inc.)	30KW-LP	Unlimited.
WBAL	Baltimore, Md.	Consolidated Gas, Electric & Power Co.	1KW	
WEW	St. Louis, Mo.	St. Louis University	1KW	Daytime.
KVI	Tacoma, Wash.	T—Des Moines, Wash. Puget Sound Broadcasting Co. (Inc.)	1KW	Limited.

770 KILOCYCLES—389.4 Meters

KFAB	Lincoln, Nebr.	KFAB Broadcasting Co.	5KW	Shares with WBBM-WJBT.
WBBM-WJBT	Chicago, Ill.	T. Glenview, Ill. WBBM Broadcasting Corp. (Inc.)	25KW	Shares with KFAB.

780 KILOCYCLES (Canadian Shared)—384.4 Meters

WEAN	Providence, R. I.	Shepard Broadcasting Service (Inc.)	{ 250W 500W-LS }	Unlimited.
WTAR-WPOR	Norfolk, Va.	WTAR Radio Corporation	500W	Do.
WMC	{ Memphis, Tenn. Tenn. }	T—Bartlett, Memphis Commercial Appeal, Inc.	{ 500W 1KW-LS }	Do.
KELW	Burbank, Calif.	Magnolia Park Ltd.	500W	Shares with KELW.
KTM	{ Los Angeles, Calif. Monica, Calif. }	T—Santa Monica, Calif. Pickwick Broadcasting Corporation	{ 500W 1KW-LS }	Shares with KTM.

790 KILOCYCLES—379.5 Meters

WGY	{ Schenectady, N. Y. Schenectady, N. Y. }	T—South General Electric Co.	50KW	Unlimited.
KGO	{ San Francisco, Calif. Oakland, Calif. }	T—National Broadcasting Co. (Inc.)	7½KW	Do.

800 KILOCYCLES—374.8 Meters

WBAP	Fort Worth, Tex.	Carter Publications (Inc.)	10KW-LP*	Shares with WFAA.
WFAA	{ Dallas, Tex. Texas. }	T—Grapevine, Texas. Dallas News and Dallas Journal A. H. Belo Corporation	50KW-LP	Shares with WBAP.

810 KILOCYCLES—370.2 Meters

WPCH	{ New York, N. Y. New York, N. Y. }	T—Hoboken, N. J. Eastern Broadcasters (Inc.)	500W	Daytime.
WCCO	{ Minneapolis, Minn. Minn. }	T—Anoka, Northwestern Broadcasting (Inc.)	5KW	Unlimited.

820 KILOCYCLES—365.6 Meters

WHAS	{ Louisville, Ky. town, Ky. }	T—Jefferson-The Courier Journal Co. and The Louisville Times Co.	10KW	Unlimited.
------	----------------------------------	--	------	------------

830 KILOCYCLES—361.2 Meters

WHDH	Boston, Mass.	T—Gloucester, Mass. Matheson Radio Co. (Inc.)	1KW	Daytime until sunset at Denver, Colo.
WRUF	Gainesville, Fla.	University of Florida	5KW	Limited.
KOA	Denver, Colo.	National Broadcasting Co. (Inc.)	12½KW	Unlimited.
WEEU	Reading, Pa.	Berks Broadcasting Co.	1KW	

840 KILOCYCLES (Canadian Exclusive)—356.9 Meters

850 KILOCYCLES—352.7 Meters

KWKH	Shreveport, La.	T—Kennon-Hello World Broadcasting Corporation	10KW	Shares with WWL.
WWL	Wood, La. New Orleans, La.	Loyola University	5KW	Shares with KWKH.

860 KILOCYCLES—348.6 Meters

WABC-WBOQ	New York, N. Y.	T—West of Queens Bay Blvd. Queens Co., N. Y.	5KW	Unlimited.
WHB	Kansas City, Mo.	T—North Kansas City, Mo. WHB Broadcasting Co.	500W	Daytime.
KMO	Tacoma, Wash.	KMO (Inc.)	500W	Limited.

870 KILOCYCLES—344.6 Meters

WLS	Chicago, Ill.	T—Crete, Ill. Agricultural Broadcasting Co.	50KW ¹⁰	Shares with WENR-WBCN.
WENR	Chicago, Ill.	T—Downers Grove, Ill. National Broadcasting Co.	50KW	Shares with WLS.

880 KILOCYCLES (Canadian Shared)—340.7 Meters

WGBI	Scranton, Pa.	Scranton Broadcasters (Inc.)	250W	Shares with WOAN.
WOAN	Scranton, Pa.	E. J. Lynett, prop. the Scranton Times	250W	Shares with WGBI.
WCOC	Meridian, Miss.	Mississippi Broadcasting Co. (Inc.)	{ 500W 1KW-LS }	Unlimited.
WSUI	Iowa City, Iowa	State University of Iowa	500W	Three-sevenths time.
KLX	Oakland, Calif.	The Tribune Publishing Co.	500W	Unlimited.
KPOF	Denver, Colo.	Pillar of Fire	500W	Shares with KFKA.
KFKA	Greeley, Colo.	The Mid-Western Radio Corporation	{ 500W 1KW-LS }	Shares with KPOF.

890 KILOCYCLES (Canadian Shared)—336.9 Meters

WJAR	Providence, R. I.	The Outlet Co.	{ 250W 400W-LS }	Unlimited.
WKAQ	San Juan, P. R.	Radio Corporation of Porto Rico	250KW	Do.
WMMN	Fairmount, W. Va.	Holt-Rowe Novelty Co.	{ 250W 500W-LS }	Do.

(890 kilocycles continued on next page)

*Licensed at present for 10 KW only.

⁹C. P. to move transmitter to Wayne, N. J., and increase power to 50 KW-LP.
¹⁰C. P. to increase power to 50 KW-LP.

BROADCASTING STATIONS BY FREQUENCIES—Continued

890 KILOCYCLES—336.9 Meters—Continued

Call letters	Main studio location	Licensese	Power	Time of operation
WGST	Atlanta, Ga.	Georgia School of Technology	{ 250W 500W-LS	Shares with WMAZ.
KGJF	Little Rock, Ark.	First Church of the Nazarene	250W	Unlimited.
WILL	Urbana, Ill.	University of Illinois	{ 250W 500W-43	Shares with KUSD and KFNF.
KUSD	Vermillion, S. Dak.	University of South Dakota	{ 500W-LS 750W-LS	Shares with WILL and KFNF.
KFNF	Shenandoah, Iowa	Henry Field Co.	{ 500W 1KW-LS	Shares with WILL and KUSD.

900 KILOCYCLES—333.1 Meters

WBEN	Buffalo, N. Y.	T—Martinsville, WBEN, Inc.	1KW	Unlimited.
WKY	Oklahoma City, Okla.	WKY Radiophone Co.	1KW	Do.
WJAX	Jacksonville, Fla.	City of Jacksonville	1KW	Do.
WLBL	Stevens Point, Wis.	State of Wisconsin, Department of Agriculture and Markets.	2KW	Daytime.
KHJ	Los Angeles, Calif.	Don Lee (Inc.)	1KW	Unlimited.
KSEI	Pocaello, Idaho	Radio Service Corp.	250W	Do.
KGBU	Ketchikan, Alaska	Alaska Radio and Service Co. (Inc.)	500W	Do.

910 KILOCYCLES (Canadian Exclusive)—329.6 Meters

920 KILOCYCLES—325.9 Meters

WBSO	Needham, Mass.	Babson's Statistical Organization (Inc.)	500W	Daytime.
WWJ	Detroit, Mich.	The Evening News Association (Inc.)	1KW	Unlimited.
KPRC	{ Houston, Tex. T—Sugarland, Texas.	Houston Printing Co.	{ 1KW 2½KW-LS	Do.
WAAF	Chicago, Ill.	Drovers Journal Publishing Co.	500W	Daytime.
KOMO	Seattle, Wash.	Fisher's Blend Station (Inc.)	1KW	Unlimited.
KFEL	Denver, Colo. ¹¹	Eugene P. O'Fallon (Inc.)	500W	Shares with KFXF.
KFXF	Denver, Colo.	Colorado Radio Corporation	500W	Shares with KFEL.

930 KILOCYCLES (Canadian Shared)—322.4 Meters

WIBG	Elkins Park, Pa.	St. Paul's P. E. Church	25W	Daytime.
WDBJ	Roanoke, Va.	Times-Royal Corp.	{ 250W 500W-LS	Unlimited.
WBRC	Birmingham, Ala.	Birmingham Broadcasting Co. (Inc.)	{ 500W 1KW-LS	Do.
KGBZ	York, Nebr.	Dr. George R. Miller	{ 500W 1KW-LS	Shares with KMA.
KMA	Shenandoah, Iowa	May Seed & Nursery Co.	500W	Shares with KGBZ.
KFWI	San Francisco, Calif.	Radio Entertainments (Inc.)	500W	Shares with KROW.
KROW	{ Oakland, Calif. T—Richmond, Calif.	Educational Broadcasting Corporation	{ 500W 1KW-LS	Shares with KFWI.

940 KILOCYCLES—319.0 Meters

WAAT	Jersey City, N. J.	Bremer Broadcasting Corporation	300W	Daytime until 6 p. m. eastern standard time.
WCSH	Portland, Me. T—Scarboro, Me.	Congress Square Hotel Co.	1KW	Unlimited.
WFIW	Hopkinsville, Ky.	WFIW (Inc.)	1KW	Do.
WHA	Madison, Wis.	University of Wisconsin	750W	Daytime.
WDAY	Fargo, N. Dak. T—West	WDAY (Inc.)	1KW	Unlimited.
KOIN	Fargo, N. Dak.	KOIN (Inc.)	1KW	Do.
KGU	Portland, Oreg. T—Sylvan, Oreg.	Marion A. Mulrony and Advertiser Publishing Co. (Ltd.)	1KW	Do.

950 KILOCYCLES—315.6 Meters

WRC	Washington, D. C.	National Broadcasting Co. (Inc.)	500W	Unlimited.
KMBC	Kansas City, Mo. T—Independence, Mo.	Midland Broadcasting Co.	1KW	Do.
KFWB	Hollywood, Calif.	Warner Bros. Broadcasting Corporation	1KW	Do.
KGHL	Billings, Mont.	Northwestern Auto Supply Co. (Inc.)	1KW	Do.

960 KILOCYCLES (Canadian Exclusive)—312.3 Meters

970 KILOCYCLES—309.1 Meters

WCFL	Chicago, Ill.	Chicago Federation of Labor	1½KW	Limited.
KJR	Seattle, Wash.	Northwest Broadcasting System (Inc.)	5KW	Unlimited.

980 KILOCYCLES—305.9 Meters

KDKA	Pittsburgh, Pa. T—Caxonburg, Pa.	Westinghouse Electric & Manufacturing Co.	50KW-LP	Unlimited.
------	----------------------------------	---	---------	------------

990 KILOCYCLES—302.8 Meters

WBZ	Springfield, Mass. T—East	Westinghouse Electric & Manufacturing Co.	15KW	Shares with WBZA.
WBZA	Springfield, Mass. ¹² Boston, Mass. ¹³	Westinghouse Electric & Manufacturing Co.	15KW	Shares with WBZ.

1000 KILOCYCLES—299.8 Meters

WHO	Des Moines, Iowa	Central Broadcasting Co.	5KW	Synchronizes with WOC experimentally.
WOC	Davenport, Iowa	do	5KW	Synchronizes with WHO experimentally.
KFVD	Culver City, Calif.	Los Angeles Broadcasting Co.	250W	Limited.

1010 KILOCYCLES (Canadian Shared)—296.8 Meters

WQAO	New York, N. Y. T—Cliffside, N. J.	Calvary Baptist Church	250W	Shares with WHN and WRNY.
WLAP	Louisville, Ky.	American Broadcasting Corp. of Kentucky	250W	
WHN	New York, N. Y.	Marcus Loew Booking Agency	250W	Shares with WQAO-WPAP and WRNY.
WPAP	New York City	Palisades Amusement Park	250W	Shares with WQAO-WPAP and WHN.
WRNY	New York, N. Y. T—Coytesville, N. J.	Aviation Radio Station (Inc.)	250W	Shares with WQAO-WPAP and WHN.
KGGF	South Coffeyville, Okla.	Hugh J. Powell and Stanley Platz, doing business as Powell & Platz.	500W	Shares with WNAD.
WNAD	Norman, Okla.	University of Oklahoma	500W	Shares with KGGF.
WIS	Columbia, S. C.	South Carolina Broadcasting Co. (Inc.)	{ 500W 1KW-LS	Unlimited.
KQW	San Jose, Calif.	Pacific Agricultural Foundation Ltd.	500W	Do.

1020 KILOCYCLES—293.9 Meters

WRAX	Philadelphia, Pa.	WRAX Broadcasting Co.	250W	Daytime.
KYW-KFKX	Chicago, Ill. T—Bloomingdale Township, Ill.	Westinghouse Electric & Manufacturing Co.	10KW	Unlimited.

1030 KILOCYCLES (Canadian Exclusive)—291.1 Meters

1040 KILOCYCLES—288.3 Meters

WMAK	Buffalo, N. Y. T—Grand Island, N. Y. ¹⁴	Buffalo Broadcasting Corporation	1KW	Limited.
WKAR	East Lansing, Mich.	Michigan State College	1KW	Daytime.
KTHS	Hot Springs National Park, Ark.	Hot Springs Chamber of Commerce	10KW	Shares with KRLD.
KRLD	Dallas, Tex.	KRLD Radio Corporation	10KW	Shares with KTHS.

¹¹ C. P. to move transmitter to Edgewater, Colo.

¹² Licensed to move transmitter to Millis Township, Mass., and studio to Boston, Mass., and consolidate with WBZA.

¹³ C. P. to move transmitter to East Springfield and increase power to 1KW.

¹⁴ C. P. to move transmitter to Amherst, N. Y.

(Continued Next Week to High Frequencies)

And at Such Prices!

- Flexible insulated coupler for uniting coil or condenser shafts of 1/4 inch diameter. Provides option of insulated circuits on both sides. Order Cat. FL-C @.....\$2.20
- Antenna coil for .0005 mfd. Order Cat. ANT-5 @..... .45
- Three-circuit tuner for .0005 mfd. Order Cat. 3-CT-5 @..... .75
- Antenna coil for .00035 mfd. Order Cat. ANT-3 @..... .47
- Three-circuit tuner for .00035 mfd. Order Cat. 3-CT-3 @..... .79
- Screen grid RF transformer, for .0005 mfd., to couple screen grid tube to next tube. Order Cat. SG-5 @..... .45
- Screen grid RF transformer, for .00035 mfd., to couple screen grid tube to next tube. Order Cat. SG-3 @..... .47
- AC electric motor and turntable, for playing phonograph records. A synchronous motor, 60 cycles; 80 turntable revolutions per minute. Order Cat. SYN-M @..... 4.45
- A battery switch (Benjamin). Order Cat. A-SW @..... .25
- A eliminator or dynamic speaker transformer (Jefferson), 20-volt secondary. Will pass 3 1/2 amps. Order Cat. 20-V-T- @..... .89
- 30-henry shielded choke for B supply filtration or filtered speaker output. Will stand 100 ma. Order Cat. OS-30HS @..... 1.65

GUARANTY RADIO GOODS CO.
143 WEST 45TH STREET, NEW YORK, N. Y.

Tubes at 30¢ Each

Four for \$1.00
171 245

Sold on basis of remittance with order. We will pay the postage.

RELIABLE RADIO CO.
143 West 45th Street New York, N. Y.

PENTODE, \$1.00 VARI-MU, \$1.00

List of Tubes and Prices

247 (pentode).....\$1.00	120	1.00
235 (vari-mu).....1.00	200A	1.00
230	WD-12	1.00
231	224	1.00
232	227	1.00
222	245	1.00
171A	210	1.00
171 (for AD)	250	2.95
112A	280	2.95
112 (for AD)	228	1.00
201A	280	1.00
201	281	2.95
UX-199	UV-199	1.00

RELIABLE RADIO CO.
143 West 45th Street, New York, N. Y.

BRACH RELAY—List price \$4.50; our price 99c. Guaranty Radio Goods Co., 143 W. 45th St., N. Y. C.

NEW DRAKE'S ENCYCLOPEDIA
1,650 Alphabetical Headings from A-battery to Zero Beat; 1,025 Illustrations, 920 Pages, 240 Combinations for Receiver Layouts. Price, \$6.00. Radio World, 145 W. 45th St., N. Y. C

Quick Action Classified Ads

Radio World's Speedy Medium for Enterprise and Sales
7 cents a word—\$1.00 minimum—Cash with Order

250 **LETTERHEADS, CARDS, ENVELOPES, STATEMENTS, BLOTTERS**, \$1.00 each. Best stock. Cape Cod Printers, Box 901, Fall River, Mass.

PRINTING: 1000 BUSINESS CARDS, with Card Case, \$1.50 postpaid. Other printing reasonable. MILLER, Printer, Narberth, Pa.

RADIO WORLD AND RADIO NEWS. Both for one year, \$7.00. Radio World, 145 W. 45th St., N. Y. City.

"THE CHEVROLET SIX CAR AND TRUCK" (Construction—Operation—Repair) by Victor W. Page, author of "Modern Gasoline Automobile," "Ford Model A Car and AA Truck," etc., etc. 450 pages, price \$2.00. Radio World, 145 W. 45th St., N. Y. City.

25,000 OHM POTENTIOMETER, wire wound, in shield case; takes 1/4" shaft. Will stand 20 ma. easily. Excellent as a volume control. Price, 90c. Direct Radio Co., 143 West 45th Street, New York, N. Y.

EBY antenna-ground binding post assembly for all circuits. Ground post automatically grounded on sets using metal chasses. Assemblies, 30c. each. Guaranty Radio Goods Co., 143 West 45th St., New York, N. Y.

U. S. BROADCASTING STATIONS BY FREQUENCY.—The Sept. 19th issue contained a complete and carefully corrected list of all the broadcasting stations in the United States. This list was complete as to all details, including frequency, call, owner, location, power and time sharers. No such list was ever published more completely. It occupied nine full pages. 15c a copy. **RADIO WORLD**, 145 West 45th Street, New York, N. Y.

TELEVISION DISC—12-inch aluminum scanning disc. Mention style and number of holes and size of mounting, \$2.00. Cash with order. LeRoy Jones, 110 22nd Ave., Melrose Park, Ill.

"RADIO FREQUENCY MEASUREMENTS", by E. B. Moullin, M.A., A.M.I.E., M.I.Rad. Eng. Second Edition entirely reset and greatly enlarged illustrated. 487 pages, plus 12-page index. India pensable for radio experts and engineers. \$12.50. Radio World, 145 W. 45th St., N. Y. City.

RADIO AND TELEVISION HOME STUDY COURSE complete, including a large schematic dictionary, for only \$10. Money back if not satisfied. Radio Engineers, R. 375 New St., Pottstown, Penna.

SERVICEMEN, MAKE THIS A FAIRWAY CHRISTMAS! Co-operate with us; feature Fairway Silver Polish. Retail 50¢; price to you for the asking. Ryber Mfg. Co., Room 1114, 1700 Walnut St., Philadelphia, Pa.

"RADIO TROUBLE SHOOTING", E. R. Haan. 328 pages, 300 illustrations, \$3. Guaranty Radio Goods Co., 143 W. 45th St., New York.

"A B C OF TELEVISION" by Yates—A comprehensive book on the subject that is attracting attention of radioists and scientists all over the world. \$3.00, postpaid. Radio World, 145 West 45th St., N. Y. City.

YOUNG MAN, 25 YEARS OLD, with commercial first-class license, desires position in broadcasting or communications station. Eight years experience in various radio work. J. Simmons, 25 East 99th St., New York City.

SERVICEMEN!
Resistor Replacement Manual
FREE with purchase of 10 Lynch Metallized Resistors, or \$1 cash
MORE THAN 200 CIRCUITS
Gives the value and code of each resistor and its position in the circuit of nearly every popular make of radio. SAVES TIME and experimenting. Eliminates guess work.
LYNCH Resistors 1/2, 1, 1 1/2, 2, and 3 Watts
Write for Manual today.
LYNCH MFG. CO., Inc., Dept. W, 1775 B'way, N. Y.

115 DIAGRAMS FREE!

115 Circuit Diagrams of Commercial Receivers and Power Supplies supplementing the diagrams in John F. Rider's "Trouble Shooter's Manual." These schematic diagrams of factory-made receivers, giving the manufacturer's name and model number on each diagram, include the MOST IMPORTANT SCREEN GRID RECEIVERS.

The 115 diagrams, each in black and white, on sheets 8 1/2 x 11 inches, punched with three standard holes for loose-leaf binding, constitute a supplement that must be obtained by all possessors of "Trouble Shooter's Manual," to make the manual complete. We guarantee no duplication of the diagrams that appear in the "Manual." Circuits include Bosch 54 D. C. screen grid; Bakite Model F. Crosley 20, 21, 22 screen grid; Eveready series 50 screen grid; Kite 224 A. C. screen grid; Peerless Electrostatic series; Philco 76 screen grid.

Subscribe for Radio World for 3 months at the regular subscription rate of \$1.50, and have these diagrams delivered to you FREE!

Present subscribers may take advantage of this offer. Please put a cross here to expedite extending your expiration date.

Radio World, 145 West 45th St., N. Y. C.

"HANDBOOK OF REFRIGERATING ENGINEERING", by Woolrich—Of great use to everybody dealing in refrigerators. \$4. Book Dept., Radio World, 145 W. 45th St., N. Y. City.



Your Choice of NINE Meters!

To do your radio work properly you need meters. Here is your opportunity to get them at no extra cost. See the list of nine meters below. Heretofore we have offered the choice of any one of these meters free with an 8-weeks subscription for RADIO WORLD, at \$1, the regular price for such subscription. Now we extend this offer. For the first time you are permitted to obtain any one or more or all of these meters free, by sending in \$1 for 8-weeks' subscription, entitling you to one meter; \$2 for 16 weeks, entitling you to two meters; \$3 for 26 weeks, \$6 for 52 weeks, entitling you to six meters. Return coupon with remittance, and check off desired meters in squares below.

RADIO WORLD, 145 West 45th Street, New York, N. Y. (Just East of Broadway)

Enclosed please find \$..... for.....weeks subscription for RADIO WORLD and please send as free premium the meters checked off below.

I am a subscriber. Extend my subscription. (Check off if true.)

- 0-5 Voltmeter D.C. No. 526
- 0-50 Voltmeter D.C. No. 527
- 8-Volt Charge Tester D.C. No. 25
- 0-10 Amperes D.C. No. 528
- 0-25 Milliamperes D.C. No. 525
- 0-50 Milliamperes D.C. No. 529
- 0-100 Milliamperes D.C. No. 530
- 0-300 Milliamperes D.C. No. 531
- 0-400 Milliamperes D.C. No. 534

NAME

ADDRESS

CITY STATE

SHORT-WAVE SPECIALTIES

EXTRA-SPECIAL FREE OFFERS OF SUBSCRIPTION PREMIUMS!

RADIO WORLD, now in its tenth year, is the first and only national radio weekly, and publishes the latest, up-to-the-second news of circuits, both of kit types and of 1931 commercial receivers, as well as news of happenings in the broadcasting field. Lists of broadcast and short-wave stations are published regularly. You get your information weekly—which means quickly—and you get it accurately, so be sure to become or remain a subscriber for RADIO WORLD. We are able to offer now specially attractive premiums, and ask you to make your choice from the well-chosen variety of parts offered on this page and on other pages of this folder. When ordering, please use coupon.

The regular subscription rates are: \$6 for one year, 52 issues, one each week; \$3 for 6 months, (26 weeks); \$1.50 for three months, (13 weeks); \$1 for 8 weeks; 15c per single copy.

TUBE-BASE TYPE COILS

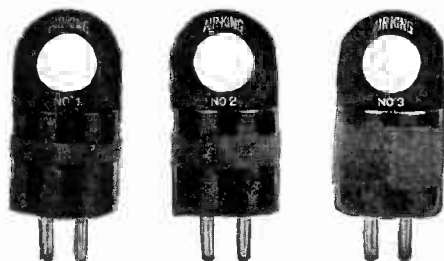

Three finger-handle type plug-in coils, wound on tube-base diameter, although of greater height than a tube base, for short wave plug-in service, where a 4-prong (UX) tube socket is used as coil receptacle. There are two separate windings, tightly coupled. The coil socket connections are: plate prong to plate, filament plus to phones; grid prong to grid and ant.; filament minus to stator of a feedback condenser. The tuning condenser (stator to grid prong, rotor to filament plus prong) may be .00015 or more for 15 to 110 meters; the feedback condenser .00025 mfd. B voltage is supplied through phones or audio transformer primary. Order PR-TBC free (less coil socket) with 6 mos. (26 weeks) subscription @ \$3.00

PRECISION PLUG-IN COILS

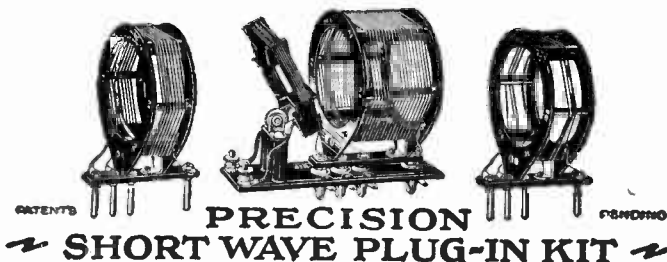

The finest short-wave coils, of de luxe construction, wound on ribs, affording 97% air dielectric, and available for various capacities of condensers, as listed below. All precision short-wave coils are provided with receptacle bases and apply to standard circuits.

For .0001 or .00015 mfd. tuning; three plug-in coils with receptacle base as illustrated, with adjustable primary built onto receptacle, 15 to 150 meters. Order PR-AK-1, free with one year's subscription @ \$6.00.

For .00025 or .0002 mfd. tuning; only two coils are required, for 15 to 150 meters. Order PR-AK-2, and get two coils, receptacle and adjustable coil (third inductance) built in. Free with nine months' subscription (39 weeks), at regular rate, \$4.50.

Note—We can supply .00015 mfd. (PR-H-15) or .0002 mfd. (PR-H-20) Hammarlund short-wave midline condenser, twins inside 2-inch diameter, with three months (13 weeks) additional subscription @ regular \$3 rate.

"DIAMOND" PAIR IN STANDARD AND DE LUXE TYPES

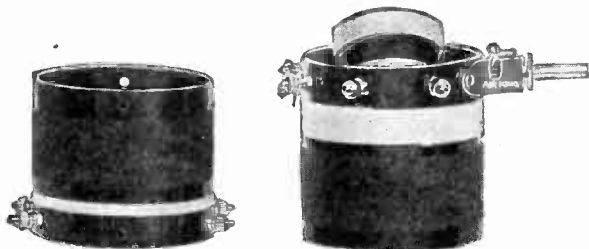

The Diamond of the Air is a popular circuit using an antenna coil and a three-circuit tuner. For this circuit the standard Diamond pair of coils consists of two, wound on 2 1/2" diameters, except for rotor on smaller form. The standard pair may be obtained for .0005 or .00035 mfd. tuning. Ticker coil has single hole panel mount. For .0005 mfd. order PR-SDP-5, with blueprint, free with a six-month subscription (26 weeks) @ \$3.00. For .00035 mfd. order PR-SDP-35, free with 6-month subscription @ \$3.00.

These coils will give extreme satisfaction and are excellent for the Diamond of the Air, being specified by Herman Bernard, the designer of the circuit.



De luxe Diamond pair, with large primaries center-tapped. For the Diamond use center tap and one extreme of the primary for antenna circuit, RF coil (at right); use full primary on tickler (lowest winding at left). The de luxe pair have silver-plated wire, for loss-reduction, wound on moulded bakelite, with threading, so coils are space-wound to reduce distributed capacity. Three-circuit coil is single-hole panel mount. Additional holes for optional base mounting on both, using brackets (not supplied.) For .0005 mfd. only. (None for .00035 mfd.) Order PR-GWN free with a year's subscription (52 issues) @ \$6.00.

GET THE COMPLETE DATA ON SHORT-WAVE CONVERTERS

Short-wave converters are all the rage. They enable you to tune in short waves on a broadcast receiver of any kind. A serial article by Herman Bernard, on this topic, discussing several models, with full-size picture diagrams, was published in the November 8th, 15th, 22nd, 29th, December 6th, 13th and 20th issues. Send \$2 for 17 weeks' subscription and get these seven issues free. Order PR-SWCS.

PLEASE USE THIS COUPON!

RADIO WORLD,
145 West 45th Street, New York, N. Y.

I hereby take advantage of your extra-special premium offers and subscribe for RADIO WORLD for the number of weeks specified in the list below. Please send indicated premium. My remittance of \$ is enclosed. RW-1-10

- | | |
|--|---|
| <input type="checkbox"/> PR-TBC (26 wks.) \$3.00 | <input type="checkbox"/> PR-SDP-35 (26 wks.) \$3.00 |
| <input type="checkbox"/> PR-AK-1 (52 wks.) 6.00 | <input type="checkbox"/> PR-GWN (52 wks.) 6.00 |
| <input type="checkbox"/> PR-AK-2 (39 wks.) 4.50 | <input type="checkbox"/> PR-SWCS (17 wks.) 2.00 |
| <input type="checkbox"/> PR-H-15 (18 wks.) 1.50 | <input type="checkbox"/> PR-SUP-3A (52 wks.) 6.00 |
| <input type="checkbox"/> PR-H-20 (13 wks.) 1.50 | <input type="checkbox"/> PR-SUP-3B (52 wks.) 6.00 |
| <input type="checkbox"/> PR-SDP-5 (26 wks.) 6.00 | <input type="checkbox"/> PR-NCV (104 wks.) 12.00 |

Name

Address

City State

Please put cross here if renewing an existing subscription.

PARTS FOR A SHORT-WAVE CONVERTER

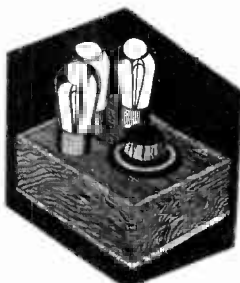

No matter what type of broadcast receiver you have, you can get short waves by using a short-wave converter built of parts we can supply. The panel is only 5 x 6 1/2 inches. There is only one tuning control. No squeals, howls or body capacity. Two models are available, one for A.C., the other for battery operation. The battery model uses three 27 tubes with heaters in series. Full details supplied with order.

All parts for A.C. model (less filament transformer, less three 27 tubes), order PR-SUP-3A, free with a year's subscription @ \$4.

All parts for the battery model (less three 27 tubes), free with a year's subscription for Radio World @ \$6.00. Order PR-SUP-3B.

A third model (of different appearance than illustrated) enables filament transformer to be built in. All parts, including filament transformer, two wound plug-in coils, 15-200 meters, Hammarlund condenser, (less tubes), order PR-NCV free with two-year subscription @ \$12.