

MAY · 1954

Proceedings

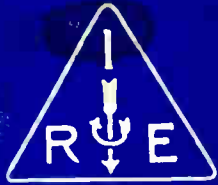

of the I · R · E

A Journal of Communications and Electronic Engineering

FERROELECTRIC MEMORY MATRIX

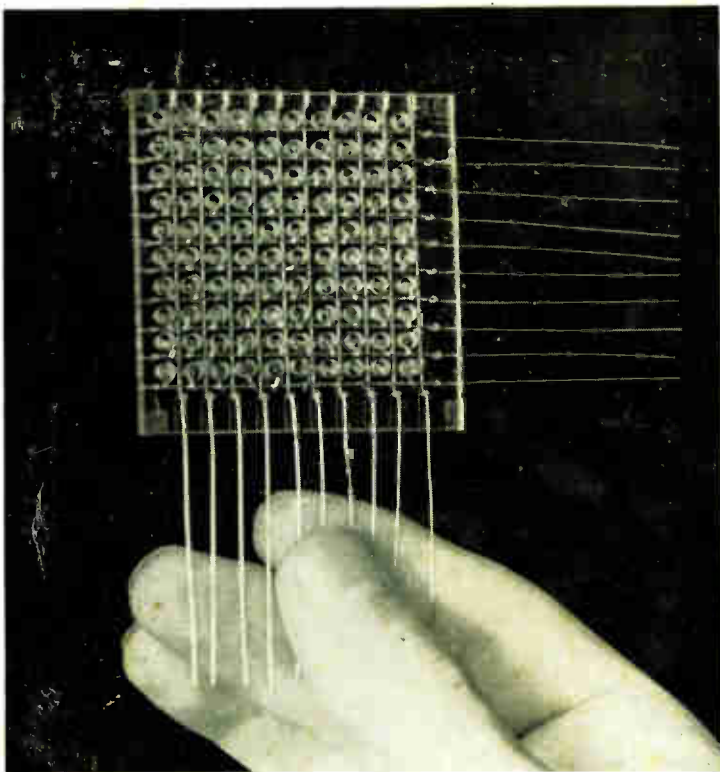

Catholic University, Air Force Computer Laboratory

Small ferroelectric storage condensers, individually selected for uniform capacity, coercive field, and sensitivity, are mounted in a cross-barlike structure to produce a simple, electrostatic memory matrix.

Volume 42

Number 5

IN THIS ISSUE

Frequency Variations of Transistor Parameters
Electron Beam Focusing
Antenna Measurements by Solar Noise
IRE Standards on Volume Measurements
Noise Source for Millimeter Waves
Transient Response in FM
Construction Practice for Transmission Equipment
Switching Time in Diodes and Transistors
Bounds on Network Responses
Matrix Analysis of Transducers
Space-Wave Fadeouts at 1,046 MC
Antenna Scattering Measurements
Abstracts and References
Annual Index to Transactions

TABLE OF CONTENTS INDICATED BY BLACK-AND-WHITE MARGIN, FOLLOWS PAGE 80A

The IRE Standards on Volume Measurements of Electrical Speech appears in this issue.

The Institute of Radio Engineers

HERMETICALLY SEALED PULSE TRANSFORMERS



RCOF CASE
1 25/64 X 61/64"

SM CASE
11/16 X 1/2"

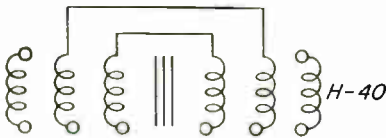

H-40

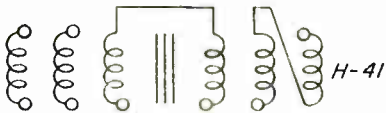

H-41

Because of the wide variety of blocking oscillator, interstage, and modulator pulse applications, the bulk of UTC pulse transformers are designed to customer's specifications. Through versatile design, however, the stock hermetic MIL-T-27 pulse transformers listed below take care of most low level applications. Wide ranges of pulse duration, loading, and level are obtainable by variations in the manner of connecting the balanced coil structure windings as shown in the engineering sheet accompanying each unit.

The H-40 and H-41 units employ identical windings suitable for different applications because of the manner in which the windings are brought out to the terminals. Pulse widths from .1 to 5 microseconds are realized with excellent fidelity. H-42 and H-43 are highly miniaturized units. They incorporate three equal windings capable of being inter-connected for wide versatility in blocking oscillator, interstage, and impedance matching service.

Type No.	Description*	Pulse Width Microsec.	Ins. Test Volts RMS	Case
H-40	Two 250 ohm windings . . . two 1000 ohm windings	.1 to 5	1000	RCOF
H-41	Two 250 ohm windings . . . two 1000 ohm windings	.1 to 5	1000	RCOF
H-42	Three 250 ohm windings	.15 to .75	500	SM**
H-43	Three 500 ohm windings	.5 to 2	500	SM**

* Impedances shown are nominal, subject to wide variation with application.
**Mtg. screw is centered on large side of case.



for SPECIAL APPLICATIONS

SERVO MOTOR MAGNETIC AMPLIFIERS

The MAT 1-4 Magnetic Amplifiers are exceptionally stable units designed for the control of 2 phase 400 cycle servo motors. They are compact . . . hermetically sealed . . . magnetically shielded . . . meet MIL-T-27 . . . high input impedance . . . high damping . . . high gain. The output is sinusoidal, amplitude variable, and phase reversible. Control is provided by a dual triode such as a 12AU7 operating with a plate voltage of 115 volts, 400 cycles, or higher. The signal to the triode grids can be polarity reversible DC or phase reversible 400 cycles. Power gain of the MAGNETIC STRUCTURE is approximately 40 . . . response time approximately 7.5 milliseconds . . . maximum null voltage 3V. RMS.

For AC signal control, the circuit of Figure 1 is employed. For DC signal control, Figure 2 applies. Figure 3 shows the use of a power transformer (MAT-5) which provides higher plate voltages and eliminates the input transformer (MAT-6). The typical response curve of Figure 4 applies to all units, the larger units feeding heavier loads.



TYPE NO.	MAT-1	MAT-2	MAT-3	MAT-4
230 Volt Supply				
Power output	4 w.	8 w.	11 w.	18 w.
RL, ohms	3300	1600	1200	720
CL, mfd.	2	.3	.5	.7
115 Volt Supply				
Power output	2 w.	4 w.	6 w.	9 w.
RL, ohms	6500	3300	2200	1450
CL, mfd.	.13	.2	.3	.45
Reson. Freq.	40 cyc.	35 cyc.	35 cyc.	20 cyc.
Log-Decr.	.18	.23	.03	.65
Cont. Wdg. Res.	6200 ohms	8450 ohms	4750 ohms	5650 ohms
Case				
Length, in.	1 1/4	1 1/2	1 3/4	2 1/8
Width, in.	1 1/16	2 1/8	2 1/2	3 1/8
Height, in.	2 3/16	2 3/4	2 1/16	3 3/8
Unit Weight, lbs.	.67	1.1	1.7	2.75
MAT-5 115V.-400 cyc. to 460 VCT; provides 230V. 48 MA DC or 460V. 24 MA DC. RC-37 Case . . . 1 3/8 x 1 3/8 x 1 1/8 . . . 1/8 mtg. holes 1 1/8 x 1 1/8 . . . 6 oz.				
MAT-6 input . . . 10,000 ohms pri . . . 1:15 C.T. ratio . . . phase shift under 1° . . . RCOF case.				

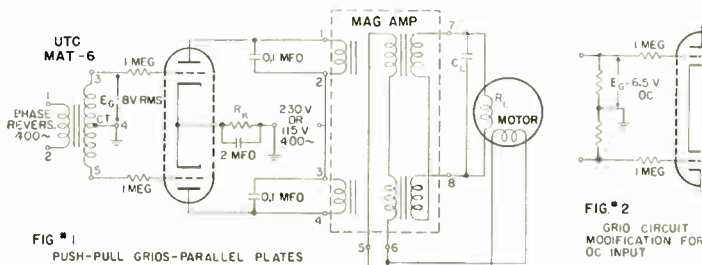

FIG. #1
PUSH-PULL GRIDS-PARALLEL PLATES

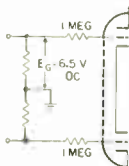

FIG. #2
GRID CIRCUIT MODIFICATION FOR DC INPUT

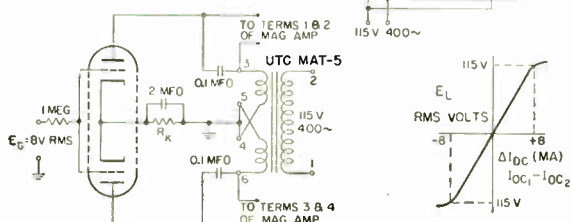

FIG. #3
PARALLEL GRIDS-PUSH-PULL PLATES

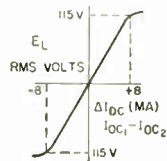
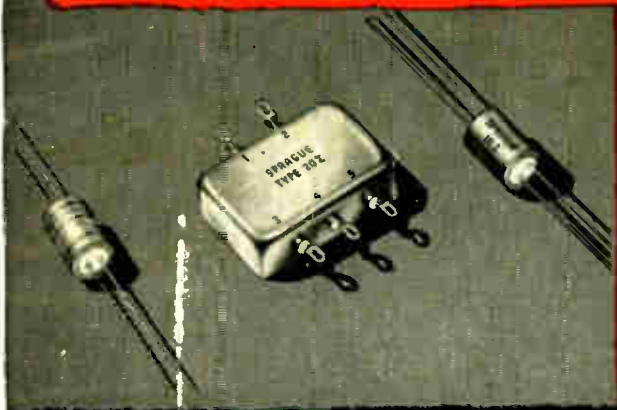

FIG. #4

United Transformer Co.
150 VARICK STREET • NEW YORK 13, N. Y.

EXPORT DIVISION: 13 EAST 40th STREET, NEW YORK 16, N. Y. CABLES: "ARLAB"

Sprague PULSE TRANSFORMERS for digital computers



Type 10Z pulse transformer at left is color-coded to customer specifications. Unit at right is standard.

As a new line of reliable components for digital computers, Sprague has introduced and is in production on pulse transformers of a new type. This transformer line is principally directed to high speed, low power computer circuits, with some designs also finding application in blocking oscillator circuits, memory ring driving circuits, etc.

Two major types are offered: a miniature transformer, Type 10Z, for 0.05 to 0.5 microsecond pulse circuits, and a larger transformer, Type 20Z, for handling pulses up to 20 microseconds in length. Intermediate sizes and plug-in units are also available for special customer requirements.

Basic data on the high reliability miniature transformer is tabulated at right. Complete details are in Engineering Bulletin M 502. A copy will be sent you on letterhead request to the Sprague Electric Company, 235 Marshall Street, North Adams, Massachusetts.

Sprague, on request, will provide you with complete application engineering service for optimum results in the use of pulse transformers for computers.

BASIC CHARACTERISTICS OF TYPE 10Z PULSE TRANSFORMERS

Pulse Duration	.05 to 0.5 microseconds.
Applications	flipflop circuits • buffer circuits pulse amplifier circuits • gating circuits • other circuits with pulse lengths up to about 0.5 microseconds.
Physical Description	Hermetically sealed. Housed in corrosion-resistant can with glass-to-metal solder-seal terminals at each end. Can length is 3/4" and diameter is 1/2". Transformers can be mounted and supported by lead wires in most applications.
Ratios Offered	Ratio 1:1 — Cat. No. 10Z3 Ratio 2:1 — Cat. No. 10Z5 Ratio 3:1 — Cat. No. 10Z4 Ratio 4:1 — Cat. No. 10Z2 Ratio 5:1 — Cat. No. 10Z1 Special Ratios Available
Maximum Repetition Rate	For a pulse length of 0.1 microsecond, pulse repetition rates up to 2 megacycles per second can be employed.
Pulse Amplitude	Normally used in circuits whose pulse amplitude varies up to 60 volts.
D-C Rating	Maximum working voltage, 300VDC. Flash tested between windings at 600VDC. May be life tested at 450 VDC between windings, 85°C, for 250 hours.
Temperature	May be operated between -55°C and +85°C. Higher temperature units available on request.
Insulation Resistance	20,000 ohms minimum between windings, measured at 25°C and 180 Volts DC.

WORLD'S LARGEST
CAPACITOR MANUFACTURER

SPRAGUE

Export For The Americas: Sprague Electric International Ltd., North Adams, Mass. CABLE: SPREXINT

VHF

... Very High Frequencies



• **RADIO INTERFERENCE**
• **and FIELD INTENSITY***
• **measuring equipment**

• **Stoddart NM-30A • 20mc to 400mc**

• **Commercial Equivalent of AN/URM-47**

PRINTED CIRCUITRY.... Modern printed circuits offer many advantages over conventional wiring, lighter weight, more compact units and freedom from many of the troubles normally encountered in conventionally-wired electronic equipment. Vibration becomes even less of a problem with printed circuits, adding to the many portable features already available with Stoddart equipment.

ADVANCED DESIGN... Specialized engineering and modern production techniques have produced one of the most advanced instruments for the accurate measurement, analysis and interpretation of radiated and conducted radio-frequency signals and interference ever manufactured. Designed to laboratory standards, rugged, and with matchless performance, the versatile NM-30A is an outstanding example of modern instrumentation. Its frequency range includes FM and TV bands.

SMALLER SIZE... A wider frequency range and higher standard of performance is incorporated into an equipment whose size is one-third that of any similar equipment ever manufactured.

SENSITIVITY... Sensitivity ranges from one to ten microvolts-per-meter, depending upon frequency and antenna in use.

APPLICATIONS... Field intensity surveys, antenna radiation pattern studies, interference location and measurement for checking radiation from virtually any mechanical or electrical device capable of generating or radiating radio-frequency signals or interference.

Stoddart RI-FI* Meters cover the frequency range 14kc to 1000mc

VLF

NM-10A, 14kc to 250kc
Commercial Equivalent of
AN/URM-6B. Very low frequen-
cies.

HF

NM-20B, 150kc to 25mc
Commercial Equivalent of
AN/PRM-1A. Self-contained
batteries. A.C. supply optional.
Includes standard broadcast
band, radio range, WWV, and
communications frequencies.
Has BFO.

UHF

NM-50A, 375mc to 1000mc
Commercial Equivalent of
AN/URM-17. Frequency range
includes Citizens band and
UHF color TV band.

Meetings with Exhibits

● As a service both to Members and the industry, we will endeavor to record in this column each month those meetings of IRE, its sections and professional groups which include exhibits.

May 5, 6 & 7, 1954

Technical Conference with Electronic Exhibits, I.R.E. Region Seven, Multnomah Hotel, Portland, Ore.

Exhibits: W. K. Dallas, Tektronix, Inc., P.O. Box 831, Portland 7, Ore.

May 7, 8, 1954

NEREM, New England Radio Engineering Meeting, Sheraton-Plaza Hotel, Boston, Mass.

Exhibits Chairman: Robert A. Waters, 4 Gordon St., Waltham 54, Mass.

May 10, 11, 12, 1954

Airborne Electronics Conference, Biltmore Hotel, Dayton, Ohio

Exhibits: R. J. McIlrath, Chairman, 410 West 1st Street, Dayton 2, Ohio

May 24, 25, 26, 1954

National Telemetering & Remote Control Conference, Morrison Hotel, Chicago, Ill.

Exhibits: Mr. Jerry Roedel, Pullman Standard Car Mfg. Co., 1414 Field Street, Hammond, Ind.

June 23, 24 & 25, 1954

IRE Symposium on Global Communications, Hotel Statler, Washington, D.C.

Exhibits: Louis De La Fleur, 77 14th St., N.W., Suite 800, Washington 5, D.C.

August 25, 26 & 27, 1954

Western Electronic Show & Convention, Pan-Pacific Auditorium, Los Angeles, Calif.

Business Manager: Mr. Mal Mobley, Jr., 344 North La Brea Ave., Los Angeles, Calif.

October 4, 5, 6, 1954

National Electronics Conference, Sherman Hotel, Chicago, Ill.

Exhibits: Mr. George H. Wise, c/o DeVry Technical Institute, 4141 Belmont Ave., Chicago 41, Ill.

November 18 and 19, 1954

Sixth Annual Electronics Conference, Hotel President, Kansas City, Mo.

Exhibits: Mr. Robert W. Butler, P.O. Box 8857, Kansas City, Mo.

February 10, 11, 12, 1955

Seventh IRE Conference, Baker Hotel, Dallas, Texas

Exhibits: T. W. Sharpe, Collins Radio Co., 1930 Hi-Line Drive, Dallas 2, Texas

Note on Professional Group Meetings:

Some of the Professional Groups conduct meetings at which there are exhibits. Working committeemen on these groups are asked to send advance data to this column for publicity information. You may address these notices to the Advertising Department, and of course listings are free to IRE Professional Groups.

STODDART AIRCRAFT RADIO Co., Inc.

6644-C Santa Monica Blvd., Hollywood 38, California • Hollywood 4-9294



**Remember
these important
MEETINGS!
NEREM**



May 6-7
Boston

Back again to the Park-Sheraton Hotel in Boston (to old timers, The Copley Plaza). This Friday afternoon-and-Saturday Meeting with exhibits is broad in interests, and a vital service to IRE members. Attend the New England Radio Engineering Meeting!



**Airborne
Electronics
Conference**

May 10-11-12
Dayton, Ohio

Once again the Dayton Section of IRE, and the IRE Professional Group on Aeronautical and Navigational Electronics join hands to produce at the Hotel Biltmore, and the Dayton Engineers Building a meeting with exhibits of high interest to all in military and civilian "air-radio".

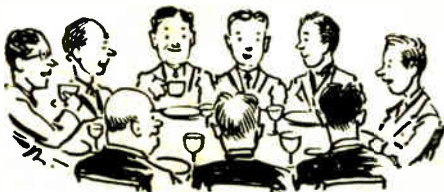

THESE EXTREMES

—or anything in between!

Langevin

TRANSFORMERS

—custom-built to military specifications
or your specific performance needs

**THREE LANGEVIN
TIME-SAVERS**

- 1** Complete MIL-T-27 tests for qualification approval can be made in our own laboratory—often saves weeks on contract completion.
- 2** Samples and short runs are handled in our model shop, staffed and equipped for high speed, economical service on small quantities.
- 3** Large stocks of materials prevent delays. Hundreds of types and sizes of wire, core materials, cases, terminals, brackets, etc., always in stock.

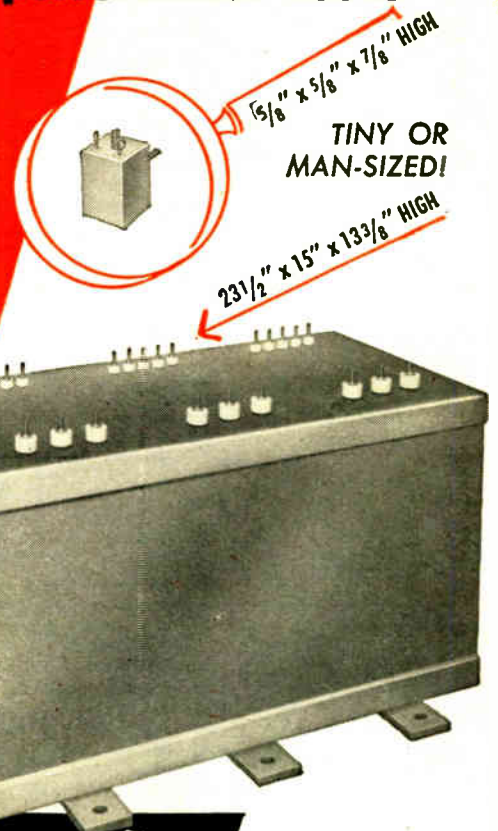

5/8" x 5/8" x 7/8" HIGH
TINY OR
MAN-SIZED!
23 1/2" x 15" x 13 3/8" HIGH

Langevin

**specialization insures faster
delivery and highest quality**

You can depend on LANGEVIN for every transformer requirement, large or small, including pulse transformers, charging reactors, saturable reactors, high cycle transformers and units built to the most rigorous specifications. Highly specialized facilities permit fast handling of short or long runs with maximum economy and rigid quality control. For prompt quotations or engineering collaboration, call or write today without obligation.



LANGEVIN MANUFACTURING CORPORATION
37 WEST 65th STREET, NEW YORK 23, N. Y.

A SUBSIDIARY OF THE W. L. MAXSON CORPORATION

REPRESENTATIVES IN ALL PRINCIPAL CITIES

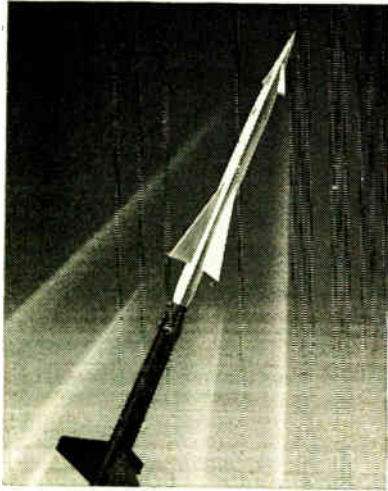

TELEPHONE SCIENCE GUIDES A **PUNCH** NO ENEMY CAN DODGE

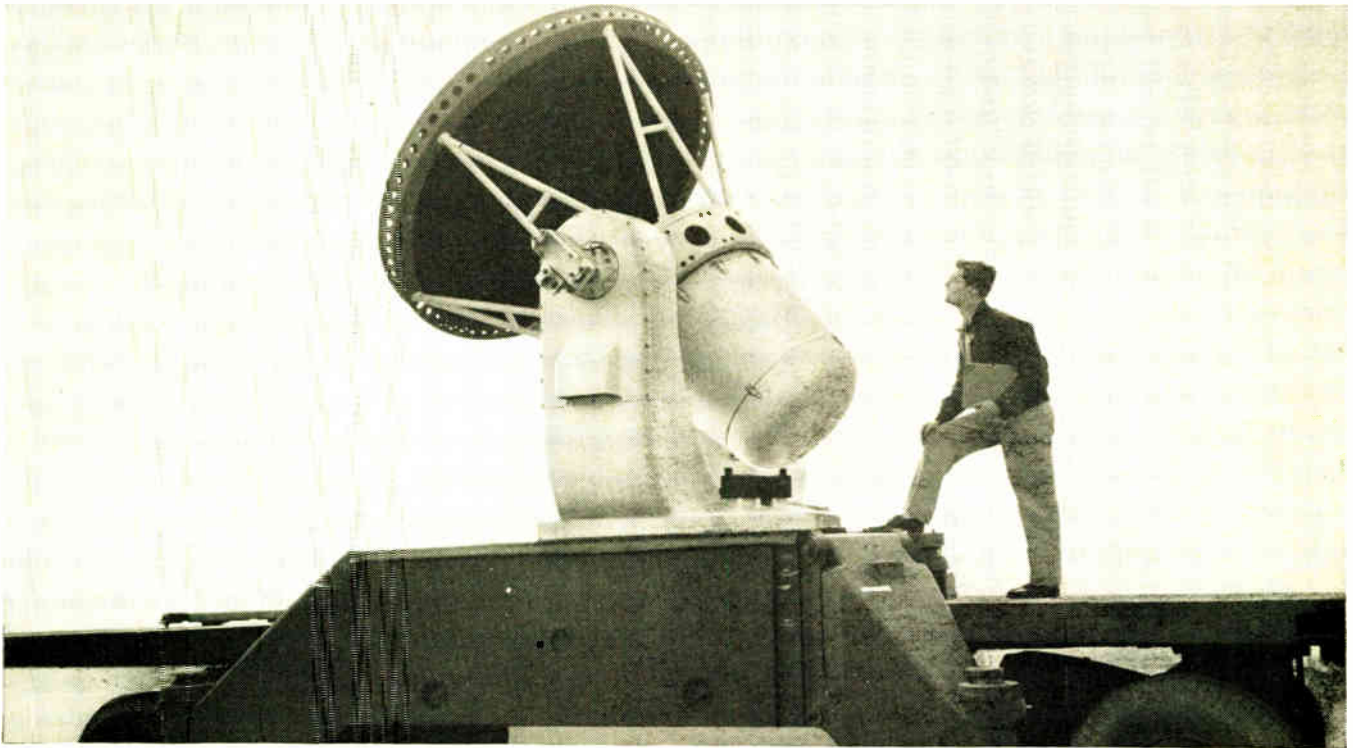

(Upper left) — Nike's missile climbs to destroy an enemy, under guidance of complex electronic controls. A radar is shown at right. Nike (pronounced Ny'kee) is named after the Greek goddess of Victory.



BELL TELEPHONE
LABORATORIES

Is it possible to guide an anti-aircraft missile so that it will track down and destroy a rapidly maneuvering target? No one knew the answer for sure when the U. S. Army put this question to Bell Telephone Laboratories in 1945.

The special skills and techniques developed to create the nation's communications network uniquely fitted Bell scientists to answer this question. They recommended a new system, Nike, and then worked to bring it into being with

engineers from Army Ordnance, Western Electric Company and Douglas Aircraft Company.

The first Nike installation has been made, and more will follow. Thus, America's defenses grow stronger through a new extension of frontiers in the communications art. It is a proud achievement of the knowledge and skills first developed at Bell Telephone Laboratories to make the nation's telephone service ever better.

Improving telephone service for America provides careers for creative men in scientific and technical fields

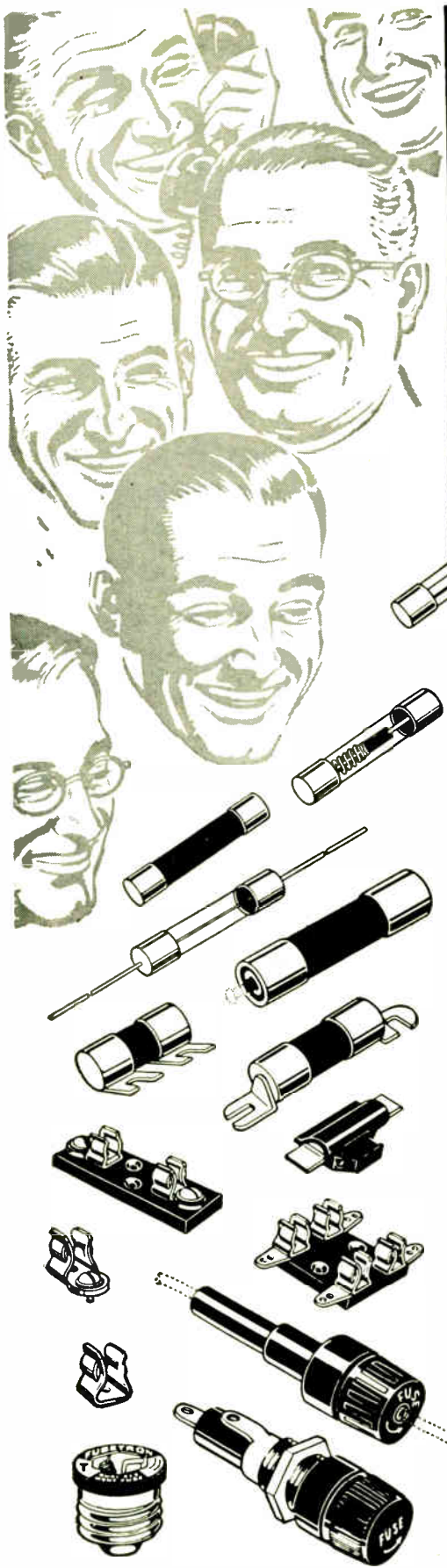

"Trouble-Free"
BUSS FUSES
can help you build
CUSTOMER
SATISFACTION

Manufacturers and service organizations know from experience that BUSS fuses won't let them down. For over 39 years, under all service conditions, BUSS fuses have given dependable electrical protection.

Rigid quality control is the reason for "trouble-free" BUSS fuses. Every BUSS fuse normally used by the electronic industries is tested in a sensitive electronic device that rejects any fuse not properly constructed, correctly calibrated and right in all physical dimensions.

So for the finest possible electrical protection, turn with confidence to BUSS fuses. The fuse that can be relied on to protect when there is trouble in the circuit. The fuse that eliminates those needless blows, which otherwise could be so annoying to your customer.

And there is another reason it pays to standardize on BUSS fuses. You can simplify your buying, stock handling and records by using BUSS as the one source for fuses. The line is complete: — standard type, dual-element (slow blowing), renewable and one-time types . . . in sizes from 1/500 ampere up.

If you have a special problem in electrical protection, Buss places at your service the world's largest fuse research laboratory and its staff of engineers. Let our engineers, who are fuse specialists, save the time of your engineers by helping you select the right fuse and fuse mounting for your job—if possible a fuse that is already available in local wholesalers' stocks.

*For more information
 mail this Coupon* ▶

BUSSMANN Mfg. Co. (Division of McGraw Electric Co.)
 University at Jefferson, St. Louis 7, Mo.

Please send me bulletin SFB containing facts on
 BUSS small dimension fuses and fuse holders.

Name _____
 Title _____
 Company _____
 Address _____
 City & Zone _____ State _____ 11E-554

Makers of a
 complete line
 of fuses for
 home, farm,
 commercial,
 electronic &
 industrial use.

Eimac Klystron Report

X557

modulating anode klystron

- Beam modulation
- Easy pulsing
- Increased efficiency

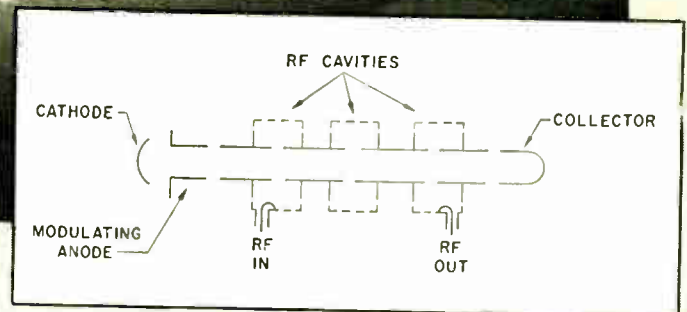
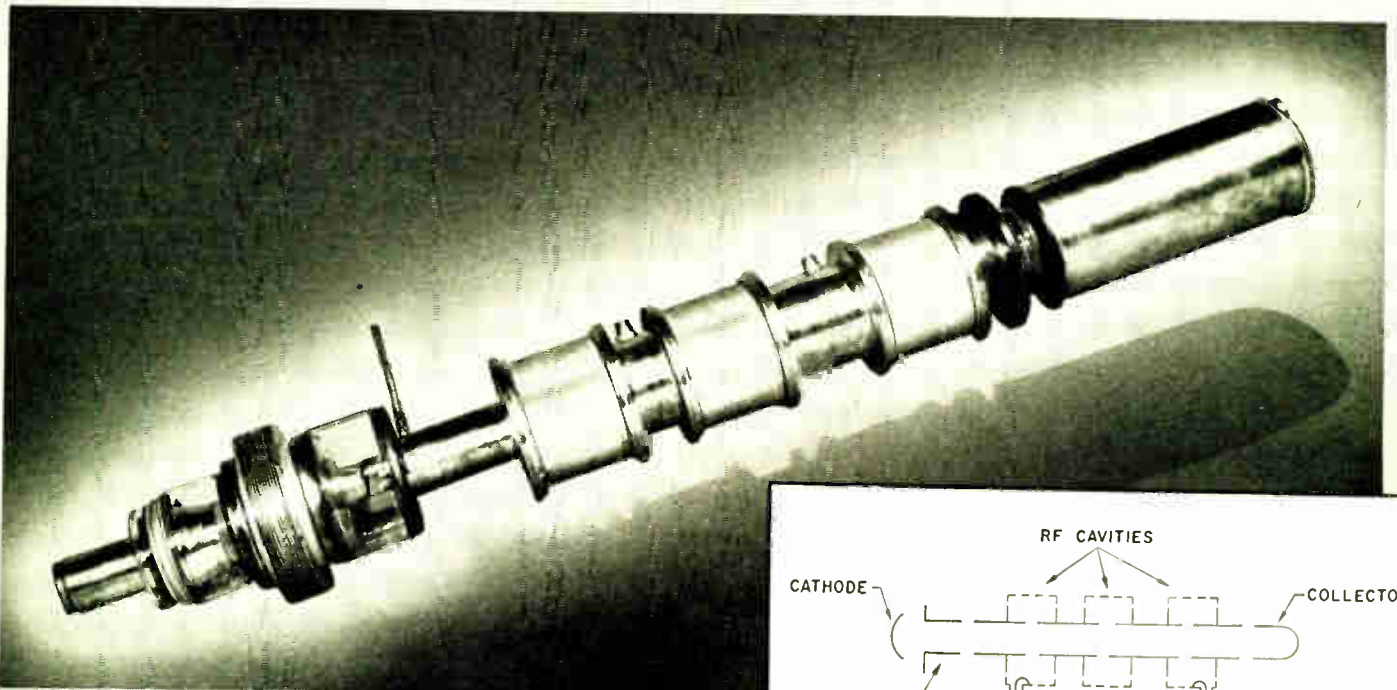

A new concept in klystron design is introduced by Eimac with the X557 modulating anode klystron. An insulated modulating anode placed between the cathode and drift tube section permits:

- Controlled variation of beam current independent of beam voltage through regulation of the modulating anode voltage
- Easy pulse modulation with low pulsing power
- Amplitude modulation with low modulating power
- 30% efficiency at carrier level with 100% amplitude modulation on top of the carrier
- Additional research and operational functions

The modulating anode klystrons are another of Eimac's klystron developments which already include high power amplifiers for UHF, including TV, and reflex klystrons for use in conditions of severe shock, vibration and sustained acceleration at frequencies to 9600mc.

● For a thorough question and answer discussion of klystrons, write our Technical Services department for a free copy of the 20-page booklet, "Klystron Facts."

EITEL-McCULLOUGH, INC.
SAN BRUNO • CALIFORNIA

Eimac

MARK OF EXCELLENCE IN
ELECTRON-POWER TUBES

INTERNATIONAL RECTIFIER

C O R P O R A T I O N



EL SEGUNDO
CALIFORNIA

Selenium Rectifiers



HIGH VOLTAGE CARTRIDGE RECTIFIERS

Made to your specifications. DC output from 20 volts to 200,000 volts.

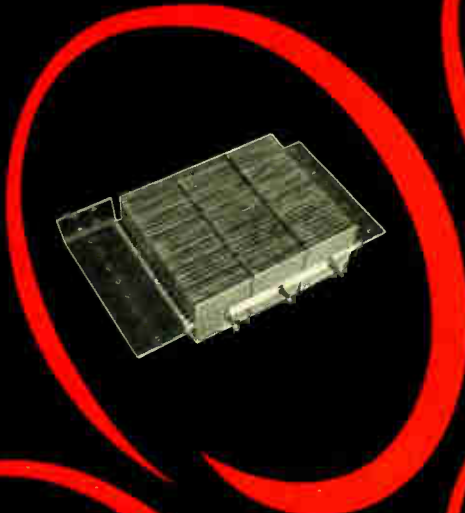

INDUSTRIAL POWER RECTIFIERS

Ratings to 250 KW
Power Factor 95%
Finest Industrial Rectifiers produced today.



HERMETICALLY SEALED

Selenium Rectifiers
Made to your specifications.



TV & RADIO MINIATURE RECTIFIERS

Widest range in the industry. Available with universal mounting for universal replacement.



HIGH TEMPERATURE GERMANIUM DIODES

"Red Dot" Series for -60°C to $+100^{\circ}\text{C}$ temperature applications.

LARGEST SUPPLIERS OF INDUSTRIAL RECTIFIERS

WRITE DEPT. D for complete descriptive literature.

INTERNATIONAL RECTIFIER

C O R P O R A T I O N

Executive Offices: 1521 E. Grand Ave., El Segundo, Calif. · Phone: OREGON 8-6281
Chicago Branch Office: 205 West Wacker Drive · Phone: Franklin 2-3889
New York Branch Office: 501 Madison Avenue · Phone: Plaza 5-8665

QUALITY CAN COST LESS

... And MALLORY Ceramic Resistors Prove It!

Wherever you need fixed resistors in television and other electronic circuits, you can get an ideal combination of quality and economy in Mallory Ceramic Resistors. They're low in cost—and their axial lead construction cuts production expense by eliminating mounting brackets, permitting point-to-point wiring and saving under-chassis space.

These features assure top quality performance:

- *Accurate resistance up to rated wattage through the use of exclusive Mallory Yard-Ohm wire.*
- *Long life: Fiberglass core contains no organic materials; high grade non-corrosive inorganic cement, injected under pressure to give high heat dissipation, holds resistance element securely. Resistors are built to take 100% overloads.*
- *Moisture protection: Resistor ends are sealed by special heat and moisture resistant compound.*
- *Rugged construction: tinned leads are securely clinched to prevent opens, high resistance and pull-outs. Non-porous steatite tubes protect against mechanical and thermal shock.*

For complete facts, write for the new catalog on fixed wire-wound resistors and carbon and wire-wound controls.

Expect more . . . Get more from **MALLORY**

Parts distributors in all major cities stock Mallory standard components for your convenience



Serving Industry with These Products:
 Electromechanical—Resistors • Switches • Television Tuners • Vibrators
 Electrochemical—Capacitors • Rectifiers • Mercury Batteries
 Metallurgical—Contacts • Special Metals and Ceramics • Welding Materials

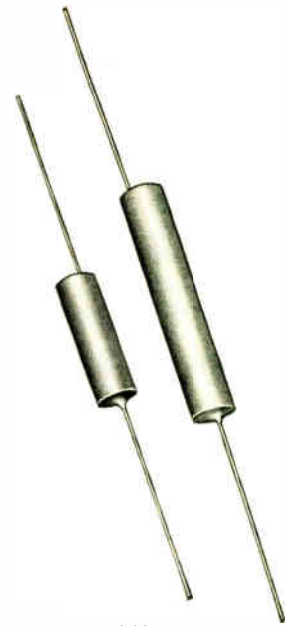

Available sizes:
 4 watt.....1 to 1000 ohms
 $\frac{5}{16}$ " dia. x 1" long
 7 watt.....1 to 5000 ohms
 $\frac{5}{8}$ " dia. x 1 $\frac{3}{4}$ " long
 Standard Tolerance.....10%

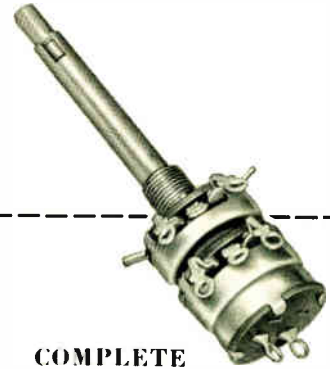

COMPLETE LINE OF CARBON CONTROLS

Factory assembled carbon controls are supplied in single, dual concentric and dual tandem constructions, with or without switch. High density, smooth surfaced element gives exceptionally low noise level, long life and minimum resistance drift. Available in standard tapers from 200 ohms to 10 megohms.

SANBORN 150 SERIES OSCILLOGRAPHIC RECORDERS

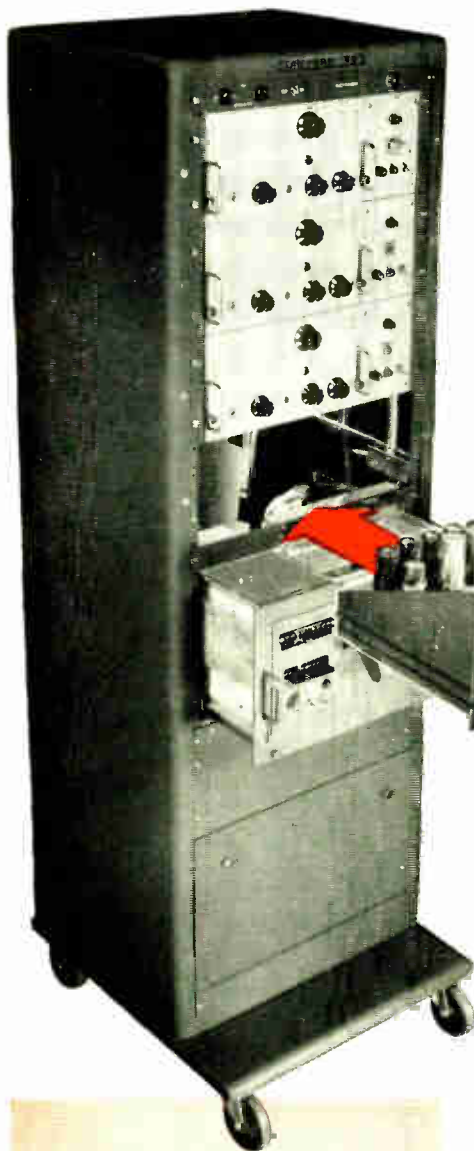

The **BASIC** four-channel assembly includes: Cabinet, Recorder, and, for each channel, a **BUILT-IN** unit (A), which comprises a Driver Amplifier with frame, and a Power Supply with control panel.

(A)



**A NEW
design concept
that brings even
greater versatility
to industrial
OSCILLOGRAPHIC
RECORDING**

(B)

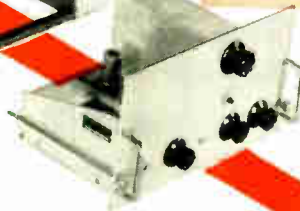

You have a **CHOICE** of readily interchangeable, plug-in Preamplifiers (B) for **EACH** channel, as described below.

The new Sanborn 150 Series offers greater operating efficiency and convenience, and encompasses a *variety of uses* which include the accurate recording of almost every phenomenon whose frequency spectrum lies in the range from 0 to 100 cycles per second.

A *wide selection* of plug-in preamplifiers, or "front end" units, such as (B) above, are completely interchangeable in any or all channels of the 150 Series amplifier section, where they simply plug in to the driver amplifier and power supply, (A) above, which are already in place.

Available plug-in Preamplifiers include: AC-DC, CARRIER, SERVO-MONITOR, DC COUPLING, LOG-AUDIO, and LOW LEVEL. Blank plug-in assemblies are also available for users to make input circuits for special measurement problems.

And, there are the popular Sanborn advantages: a high torque movement (200,000 dyne cms per cm deflection), direct *inkless* recording in *true rectangular coordinates*, and provision for code and time markings.

A new catalog on Sanborn Oscillographic Recording Systems and their components will be sent gladly on request.

OTHER SANBORN IMPROVEMENTS

- Extended frequency response.
- Improved regulated power supply.
- Individual stylus temperature control for **EACH** channel.
- Improved, single control, paper speed selector. Nine speeds — 0.25 to 100 mm/sec.
- Recorder slides out, if desired, for better view of recorded events, or for notations on record (illustrated at right).
- Improved control of input signals by use of 1, 2, 5 ratios on attenuator.



SANBORN COMPANY

INDUSTRIAL DIVISION

195 MASSACHUSETTS AVENUE

CAMBRIDGE 39, MASS.

ELECTRICALLY AND MECHANICALLY INTERCHANGEABLE

THE KENYON TWINS

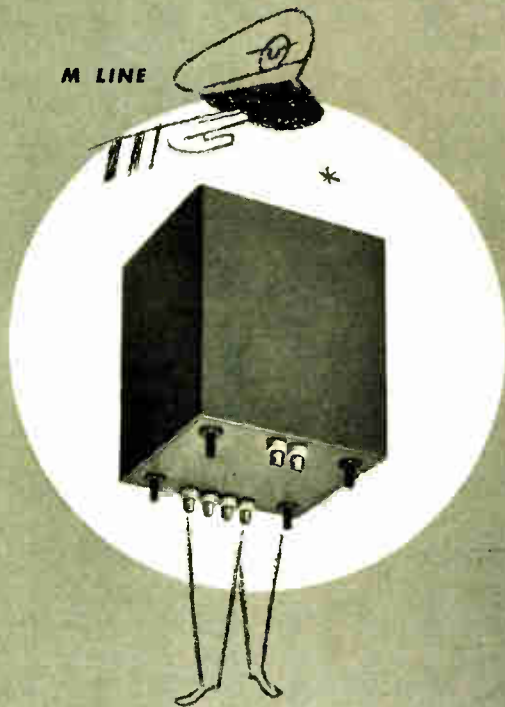

MEETS ALL MIL-T-27 REQUIREMENTS

Completely hermetically sealed to meet MIL-T-27 specifications. Military Standard types are included. Catalog Listing M L

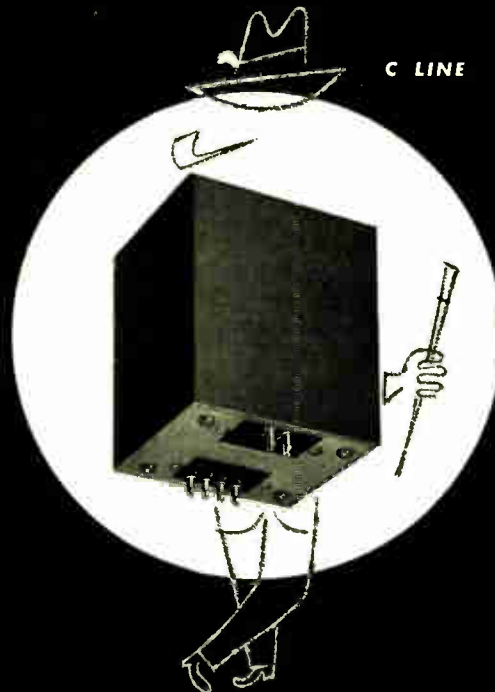

MEETS ALL CIVILIAN REQUIREMENTS

A complete line to MIL electrical specifications, housed in conventional cases. Satisfactory performance at substantial savings. Catalog Listing C L

HOUSED IN CASES WITH STANDARD MIL-T-27 DIMENSIONS, BOTH LINES CARRY THE USUAL KENYON GUARANTEE



The new Kenyon Military and Commercial Lines feature the very latest practice, *using the best class "A" wire and insulation now available, and the latest types of core material*, to obtain minimum size at reasonable cost. . . . Cases are identical to the requirements in the MIL-T-27 specification and standard units are finished in a smooth, durable medium gray. Other colors are available on special order. Full rating information and schematic is furnished in the form of a stencil on each case. . . . Special units with other ratings and the same or similar cases are available on short delivery, in any quantity. Class B, class C, and class H units can also be delivered no special order. Where casing is not required yet sealing is important, we recommend our "Ken-Seal" molded transformers, available on special order. Write for catalog. Your inquiry will receive prompt attention.

KENYON TRANSFORMER CO., INC., 840 Barry St., New York 59

Standardized for your convenience!

General Ceramics ALUMINA CERAMIC*

*Conforms to the requirements of Grade L-5A in accordance with JAN-1-10.

SOLDERSEAL HERMETIC TERMINALS

THE ITEMS SHOWN ARE STANDARD STOCK TERMINALS. DIMENSIONAL TOLERANCE, $\pm 1\frac{1}{2}\%$ BUT NOT LESS THAN $\pm .010''$

featuring

- High Mechanical Strength
- Resistance to Thermal Shock
- Fast, Easy Installation
- Permanent Hermetic Sealing

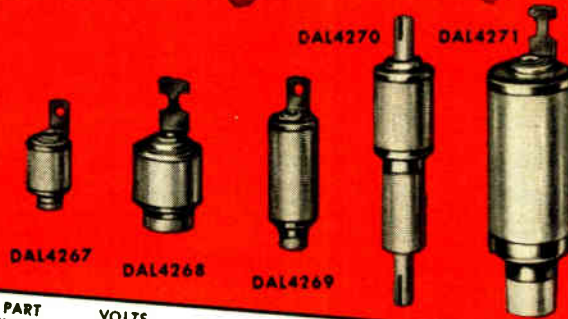
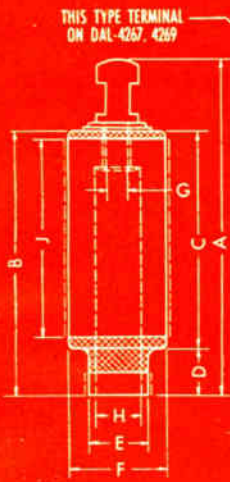

PART NUMBER	VOLTS RMS†	DIMENSIONS								
		A	B	C	D	E	F	G	H	J
DAL4267	4000	.547	.375	.281	.093	.125	.234	.046	.084	.250
DAL4268	5000	.687	.422	.312	.109	.250	.359	.069	.171	.281
DAL4269	8000	.875	.687	.562	.125	.156	.250	.046	.093	.531
DAL4270*	10000	1.187	.937	.437	.500	.234	.312	-	-	.375
DAL4271	15000	1.531	1.250	.937	.312	.281	.453	.090	.187	.781

*Note: Part No. DAL4270 employs solid thru-stud slotted at each end.

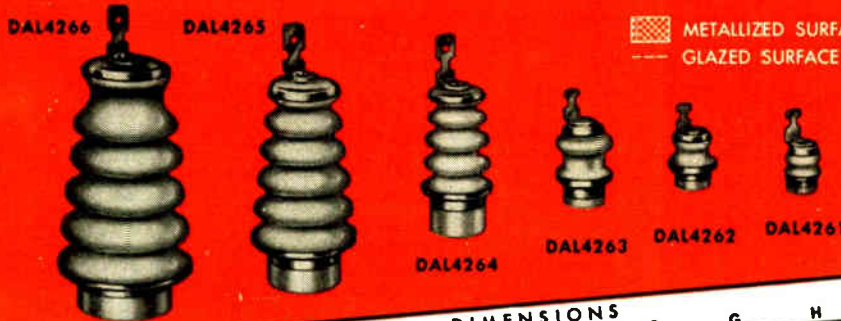

PART NUMBER	VOLTS RMS†	DIMENSIONS								
		A	B	C	D	E	F	G	H	J
DAL4261	3000	.672	.391	.282	.109	.250	.312	.067	-	.171
DAL4262	4000	.750	.468	.312	.156	.312	.437	.067	-	.160
DAL4263	7000	.968	.687	.500	.187	.375	.500	.095	.156	.375
DAL4264	14000	1.343	1.250	.907	.343	.490	.625	.128	.250	.812
DAL4265	18000	2.218	1.750	1.407	.343	.656	.937	.118	.312	1.250
DAL4266	22000	2.655	2.187	1.844	.343	.812	1.187	.128	.375	1.640

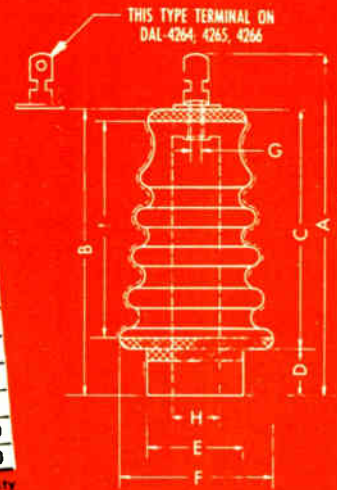

These terminals are made of glazed Alumina Ceramic. Lugs and eyelets are hot tinned brass and metallized areas are silver fired on ceramic, copper electroplated and tin fused for soft soldering. Im-

mersion in 60/40 solder at 450°F for 1½ minutes for dip soldering will not injure the metallic coating. For complete information and quotations call, write or wire today.



General CERAMICS CORPORATION
 VALLEY 6-5100
 GENERAL OFFICES and PLANT: KEASBEY, NEW JERSEY

MAKERS OF STEATITE, ALUMINA, ZIRCON, PORCELAIN, SOLDERSEAL TERMINALS, LIGHT DUTY REFRACTORIES, CHEMICAL STONWARE, IMPERVIOUS GRAPHITE, FERRIMC MAGNETIC CORES

Something New Has Been Added!



The 21 IRE Professional Groups show the expansion pattern of a modern engineering society in meeting the diversified needs of its members in the ever widening science of radio-electronics.

Membership in a Professional Group is open to any paid-up member of the I.R.E. The cost is only an annual extra publications fee, usually \$2. This fee is shown in the descriptions that follow.

An IRE Member may join as many Professional Groups as serve his interest and wishes. Such membership serves to associate him with other engineers of the same specialized interests within the radio-electronic field.

The 21 Professional Groups are listed below, together with a brief definition of each, the name of the Group Chairman, and publications to date.
* Means still available.

<p>Aeronautical and Navigational Electronics</p> <p><i>The application of electronics to operation and traffic control of aircraft and to navigation of all craft.</i></p> <p>Dr. K. Charlton Black, Chairman, Polytechnic Research & Development Co., 55 Johnson Street, Brooklyn 1, N.Y.</p> <p>Fee \$2. 8 Transactions, 4 Newsletters. *4, *5, *6, *8, & *9, and Newsletters.</p>	<p>Antennas and Propagation</p> <p><i>Technical advances in antennas and wave propagation theory and the utilization of techniques or products of this field.</i></p> <p>Mr. P. S. Carter, Chairman, c/o RCA Laboratories, Rocky Point, L.I., N.Y.</p> <p>Fee \$4. Four transactions published. *4 Vol. 1, No. 1; Vol. 1, No. 2.</p>	<p>Audio</p> <p><i>Technology of communication at audio frequencies and of the audio portion of radio frequency systems, including acoustic terminations, recording and reproduction.</i></p> <p>Mr. Vincent Salmon, Chairman, Stanford Research Institute, Stanford, California.</p> <p>Fee \$2. Published 14 Transactions, 4 Newsletters. *5, *7, *9, *10.</p>
<p>Broadcast & Television Receivers</p> <p><i>The design and manufacture of broadcast and television receivers and components and activities related thereto.</i></p> <p>Mr. Earl I. Anderson, Chairman, Assistant Manager, Industry Service Lab., RCA Laboratory Div., 711-5th Ave., New York, N.Y.</p> <p>Fee \$2. Transactions *1, *2, *3, *5</p>	<p>Broadcast Transmission Systems</p> <p><i>Broadcast transmission systems engineering, including the design and utilization of broadcast equipment.</i></p> <p>Mr. Lewis Winner, Chairman, Editor, Television Engineering, 52 Vanderbilt Avenue, New York 17, N.Y.</p> <p>Fee \$2. Convention Report. *1, *2, *3, *5</p>	<p>Circuit Theory</p> <p><i>Design and theory of operation of circuits for use in radio and electronic equipment.</i></p> <p>Dr. Chester H. Page, Chairman, National Bureau of Standards, Connecticut Ave., Washington 25, D.C.</p> <p>Fee \$2. *PGTC-1, *PGCT-2, Transactions.</p>

THE INSTITUTE OF RADIO

IRE's 21 Professional Groups

<p>Communications Systems</p> <p><i>Radio and wire telephone, telegraph and facsimile in marine, aeronautical, radio-relay, coaxial cable and fixed station services.</i></p> <p>Col. John Hessel, Chairman, Signal Corps Engineering Laboratories, Fort Monmouth, N.J.</p> <p>Fee \$2. *Vol. CS-1, No. 1, *Vol. CS-2, No. 1.</p>	<p>Component Parts</p> <p><i>The characteristics, limitations, applications, development, performance and reliability of component parts.</i></p> <p>Mr. Floyd A. Paul, Chairman, Supervisor, Electronic Reliability Sec., Dept. 3230, Northrop Aircraft, Inc., Hawthorne, Calif.</p> <p>Fee \$2. Transaction* PGCP*1.</p>	<p>Electron Devices</p> <p><i>Electron devices, including particularly electron tubes and solid state devices.</i></p> <p>Dr. Leon S. Nergaard, Chairman, RCA Laboratories, Princeton, N.J.</p> <p>Fee \$2. Transactions *1, *2, *3, *4.</p>
<p>Electronic Computers</p> <p><i>Design and operation of electronic computers.</i></p> <p>Mr. John H. Howard, Chairman, Burroughs Corp., 511 North Broad Street, Philadelphia 23, Pa.</p> <p>Fee \$2. Transactions 1, 2, and *Vol. EC-2, No. 2, *Vol. EC-2, No. 3, *Vol. EC-2, No. 4.</p>	<p>Engineering Management</p> <p><i>Engineering management and administration as applied to technical, industrial and educational activities in the field of electronics.</i></p> <p>Gen. Tom C. Rives, U.S.A. (Ret'd.), Chairman, General Electric Company, Electronics Park, Syracuse, N.Y.</p> <p>Fee \$1. Convention Report.</p>	<p>Industrial Electronics</p> <p><i>Electronics pertaining to control, treatment and measurement, specifically in industrial processes.</i></p> <p>Dr. Eugene Mittelmann, Chairman, Consulting Engineer, 549 W. Washington Blvd., Chicago 6, Ill.</p> <p>Fee \$2. Convention Report, *PGIE-1.</p>
<p>Information Theory</p> <p><i>Information theory and its application in radio circuitry and systems.</i></p> <p>Dr. William G. Tuller, Chairman, Melpar, Inc., 452 Swann Ave., Alexandria, Va.</p> <p>Fee \$2. Transaction 1. *PGIT-2.</p>	<p>Instrumentation</p> <p><i>Measurements and instrumentation utilizing electronic techniques.</i></p> <p>Mr. Ivan G. Easton, Chairman, General Radio Co., 275 Massachusetts Ave., Cambridge 39, Mass.</p> <p>Fee \$1. Transactions 1. *2. Convention Report</p>	<p>Medical Electronics</p> <p><i>The application of electronics engineering to the problems of the medical profession.</i></p> <p>Mr. L. H. Montgomery, Jr., Chairman, 612 Craighead Street, Nashville, Tenn.</p> <p>Fee \$1. *Convention Report, *PGME-1.</p>
<p>Microwave Theory and Techniques</p> <p><i>Microwave theory, microwave circuitry and techniques, microwave measurements and the generation and amplification of microwaves.</i></p> <p>Mr. Andre G. Clavier, Chairman, Federal Telecommunication Laboratories, 500 Washington Ave., Nutley, N.J.</p> <p>Fee \$2. *Vol. MTT-1, No. 2.</p>	<p>Nuclear Science</p> <p><i>Application of electronic techniques and devices to the nuclear field.</i></p> <p>Dr. Lloyd V. Berkner, Assoc. Universities, Inc., 350 5th Ave., New York 1, N.Y.</p> <p>Fee \$2.</p>	<p>Quality Control</p> <p><i>Techniques of determining and controlling the quality of electronic parts and equipment during their manufacture.</i></p> <p>Mr. Leon Bass, Chairman, Manager, Quality Eng., Jet Eng. Dept., General Electric Co., Cincinnati 15, Ohio.</p> <p>Fee \$2. Transactions, *PGQC-1, *PGQC-2.</p>
<p>Radio Telemetry and Remote Control</p> <p><i>The control of devices and the measurement and recording of data from a remote point by radio.</i></p> <p>Mr. Martin V. Kiebert, Jr., Chairman, P. R. Mallory & Co., Inc., Tuner Div., Indianapolis 6, Ind.</p> <p>Fee \$1. Convention Report.</p>	<p>Vehicular Communications</p> <p><i>Communications problems in the field of land and mobile radio services, such as public safety, public utilities, railroads, commercial land transportation, etc.</i></p> <p>Mr. W. A. Shipman, Chairman, Columbia Gas Sys. Ser. Corp., 120 East 41 Street, New York 17, N.Y.</p> <p>Fee \$2. *2, *3.</p>	<p>Ultrasonics Engineering</p> <p><i>Ultrasonic measurements and communications, including underwater sound, ultrasonic delay lines, and various chemical and industrial ultrasonic devices</i></p> <p>Mr. A. L. Lane, Chairman, 706 Chillum Road, Apt. 101, Hyattsville, Md.</p> <p>Fee \$2.</p>

ENGINEERS 1 East 79th Street, New York 21, N. Y.



May 1954

High Fidelity Crystal Cartridges

Rockbar Corp., 215 E. 37 St., New York 16, N. Y., has announced two new types of high fidelity crystal cartridges, manufactured in England by Collaro. It is claimed that these cartridges reproduce a smoother response than has previously been attained in crystal cartridges.

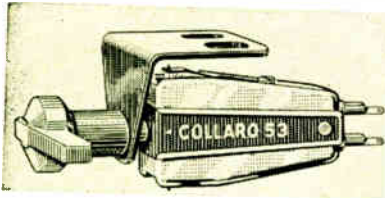

The Collaro cartridges are nonhygroscopic. They employ metal-sealed crystals impervious to normal humidity and temperature changes. They are designed to operate into a 1 megohm impedance and require no low frequency equalization.

The two types are identified as "O" and "P." These differ only in over-all frequency response and voltage output. Type "O" has a frequency response from 50 to 10,000 cycles 4-db, and a 0.5-volt output; Both cartridge types are of the "turnover" variety and are supplied with two interchangeable sapphire styli: 0.003 inch for standard, and 0.001 inch for microgroove. Standard $\frac{1}{2}$ inch mounting permits ready replacement of existing types.

Small Heater Rectifier

Vector Electronic Co., 3352 San Fernando Rd., Los Angeles 65, Calif., has a small rectifier-filter circuit which was developed especially for reducing hum by supplying dc heater current to the first stage of low level amplifiers. It is provided with an octal plug for convenient mounting and occupies a space above the chassis measuring only $1\frac{3}{4} \times 1\frac{1}{2} \times 4$ inches.

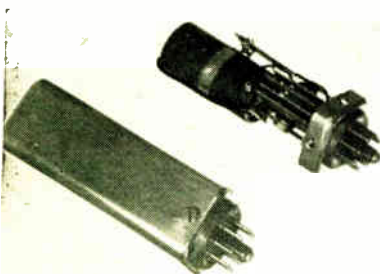

Since its rated input voltage is 6.3 to 7.5 volts ac, the device can be connected directly to the available ac filament supply. It provides up to 0.3 amperes dc, the dc output voltage being about 85 per cent of the ac input voltage at 0.3 amperes load, 95 per cent at 0.15 amperes load. Filtering is adequate to reduce the ac component in the load over 20 db.

Because of its small size the device can frequently be applied to existing amplifiers.

These manufacturers have invited PROCEEDINGS readers to write for literature and further technical information. Please mention your I.R.E. affiliation.

Tape Resistors for Printed Circuits

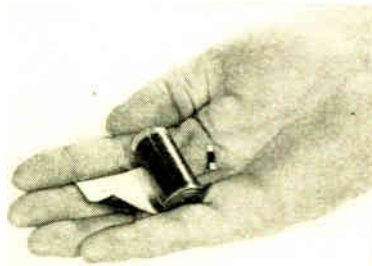

Sanders Associates, Inc., 137 Canal St., Nashua, N. H., now offers stable tape resistors for a wide range of printed circuit applications. They are available either as cured, ready-to-use resistors $\frac{1}{2}$ inch long, $\frac{1}{8}$ inch wide, and $\frac{1}{100}$ inch thick, or as uncut, uncured tape rolls. Both types have a resistance range of 100 ohms to 10 megohms. These components conform to all JAN-R-11 specifications. These resistors are suitable for semi-automatic applications in which a single operation, requiring less than one second, fastens them permanently to the chassis and connects them into the circuit, without soldering, bending or punching holes in chassis. Characteristics are as follows: Power rating: $\frac{1}{2}$ watt at 150° C, resistance tolerance: ± 10 per cent. Operating temperature range -55° C to +200° C, humidity: 95 per cent at 40° C for 250 hours, temperature coefficient: within requirements of JAN-R-11, shelf life: 18 months minimum, load life: 500 hours minimum $\frac{1}{2}$ watt at 150° C.

Remote Control Equipment For Broadcast Transmitters

The Hammarlund Mfg Co., 460 W. 34 St., New York 1, N. Y., has a brochure available describing its remote control equipment for broadcast transmitters. This type of operation by broadcasting companies was made possible recently through a new directive of the Federal Communications Commission.

The control equipment makes use of audio tones for complete control and metering of the remote transmitter including nine possible control functions and nine telemetering functions.

It makes use of recognized principles of telemetering and requires only a single circuit which may be wire, radio or microwave. No dc line is needed.

All the requirements of the Federal Communications Commission rules and regulations are fulfilled by the Hammarlund equipment.

Low-Frequency Noise Generator

The model RUG-1-10 low-frequency noise generator manufactured by Statistical Instrument Co., P.O. Box 552, Church St. Station, New York 8, N. Y., makes available for simulation studies and test purposes a random voltage source of controlled frequency spectrum and probability distribution.

Examples of the use of the RUG-1-10 are: a study of random airload effects in airframe design, noise problems in missile guidance, study of the statistical properties of ground electromagnetic reflection, low frequency phenomena including chemical and thermal processes and certain bioelectrical effects.

The basic noise source is a gas tube producing an approximate Gaussian output. This provides the signal source to the three controlled distribution channels generating the Gaussian, Rayleigh, and Uniform distributions. These distributions are accurate to 2 per cent. The frequency coverage is from 0-10 cps in three steps, 0-2, 0-5, 0-10 cps for all three distributions. Wider bandwidths are available on request. The RUG-1-10 will deliver approximately 5 volts RMS at the wide bandwidth and 1 volt at the narrow setting, and is continuously variable to 0.1-volt accuracy. Either cabinet or relay rack mounted is supplied. Size $7\frac{1}{2} \times 19 \times 19$ inches.

Low Cost Resistor

Reduced cost, states Clarostat Mfg. Co., Inc., Dover, N. H., distinguishes its Series 47 twisted tab control. This twisted-tab mounting eliminates the usual bushing, lockwasher and nut, effecting the economy. The unit is mounted by inserting the tabs through slots in panel or chassis, and twisting them to secure the control in place.

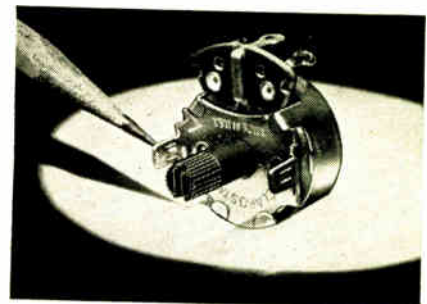

Electrically, the control is the same as the Clarostat Series 47, 15/16 inch diameter units. Available with or without switch. In resistance values from 500 ohms to 5 megohms; 0.5 watt rating; choice of tapers and taps; all types of metal or plastic shafts, including, if desired, a rear protruding slotted shaft. For more information write for drawing number 251914.

(Continued on page 24A)

**Vacuum Tube Voltmeter
Audio Oscillator
Equalization Filters**



Three-in-one — Easily Portable

DAVEN **TRANSMISSION** **MEASURING SET** **TYPE 12-A**

**For Measuring the
Characteristics
of Microwave
Relay Systems**

This unit provides the necessary information on transmission characteristics for the installation of terminal equipment, for the maintenance of terminal equipment, and for the field service of transmission lines and terminal equipment for microwave relay systems.

In one portable unit for efficient field use are combined the functions which normally would be performed by a separate Vacuum Tube Voltmeter, Audio Oscillator and Equalization Filters.

This unit has filters for providing response curves for accurate indication of 144, F1A or flat transmission lines. The 12-A also has provision for measurement of harmonic distortion and has its own self-contained low distortion 1000 cycle oscillator with variable amplitude.

The amplifier of the 12-A provides range levels from plus 20 to minus 80 DBM in calibrated steps of 10 Db. The associated meter is calibrated in 0.5 Db steps. The dynamic characteristics of the indicating meter are such that its response approximates the speed of appreciation of sounds by the ear.

This unit has line blocking capacitors for use across central battery and dial telephone lines.

Write for additional specific information and for catalog material.



THE **DAVEN** co. 195 Central Avenue
Newark 4, New Jersey

WORLD'S LARGEST MANUFACTURERS OF ATTENUATORS
PROCEEDINGS OF THE I.R.E. May, 1954

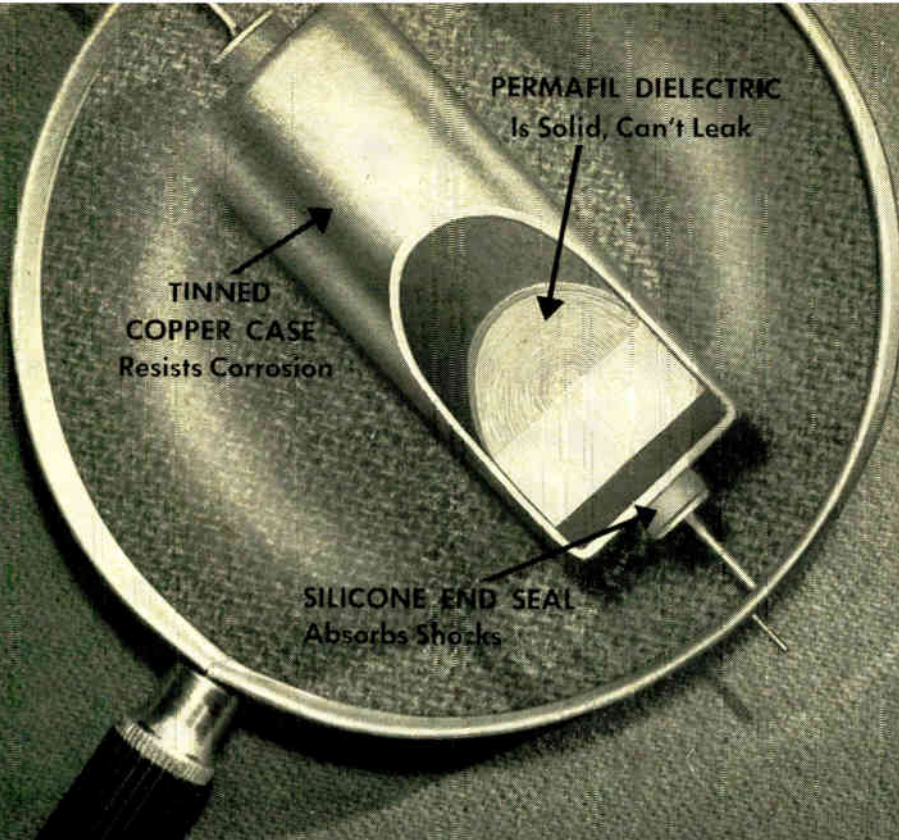

G-E SUBMINIATURE METAL-CLAD CAPACITORS

With silicone end-seals and solid dielectric operate from -55C to +125C without derating

These G-E subminiature metal-clad capacitors are specifically designed to provide the utmost reliability under severe operating conditions. For over three years, Permafil (solid) dielectric has proved its reliability in aircraft engine control, airborne radio and radar communication equipment, ground radio communication and airborne fire control systems.

G-E subminiature metal-clad capacitors offer two important, unique features:

- **Solid dielectric**—G.E.'s Permafil—provides excellent electrical characteristics and eliminates the possibility of leakage.
- **Silicone end seals**—for high thermal and physical shock resistance exceeding MIL-C-25A requirements.

- **Microfarad ratings** range from .001 to 1.0 uf in voltage ratings of 100, 200, 300, 400 and 600 volts d-c working. They can be operated at full voltage up to altitudes of 50,000 feet.

Case sizes range from .235 inches in diameter and 11/16 inches in length to 1 inch in diameter and 2 5/8 inches in length.

Liquid-filled metal-clad line also available with G-E Pyranol* dielectric for operation from -55C to +85C without derating. Lower-cost, they incorporate all the operating advantages of the solid dielectric line and are supplied in the same ratings.

For more information see your G-E Apparatus Sales Office, or write for bulletin GEC-987 to General Electric Co., Sect. 442-18, Schenectady 5, N. Y.

*Reg. trademark of General Electric Co.

You can put your confidence in—

GENERAL  ELECTRIC

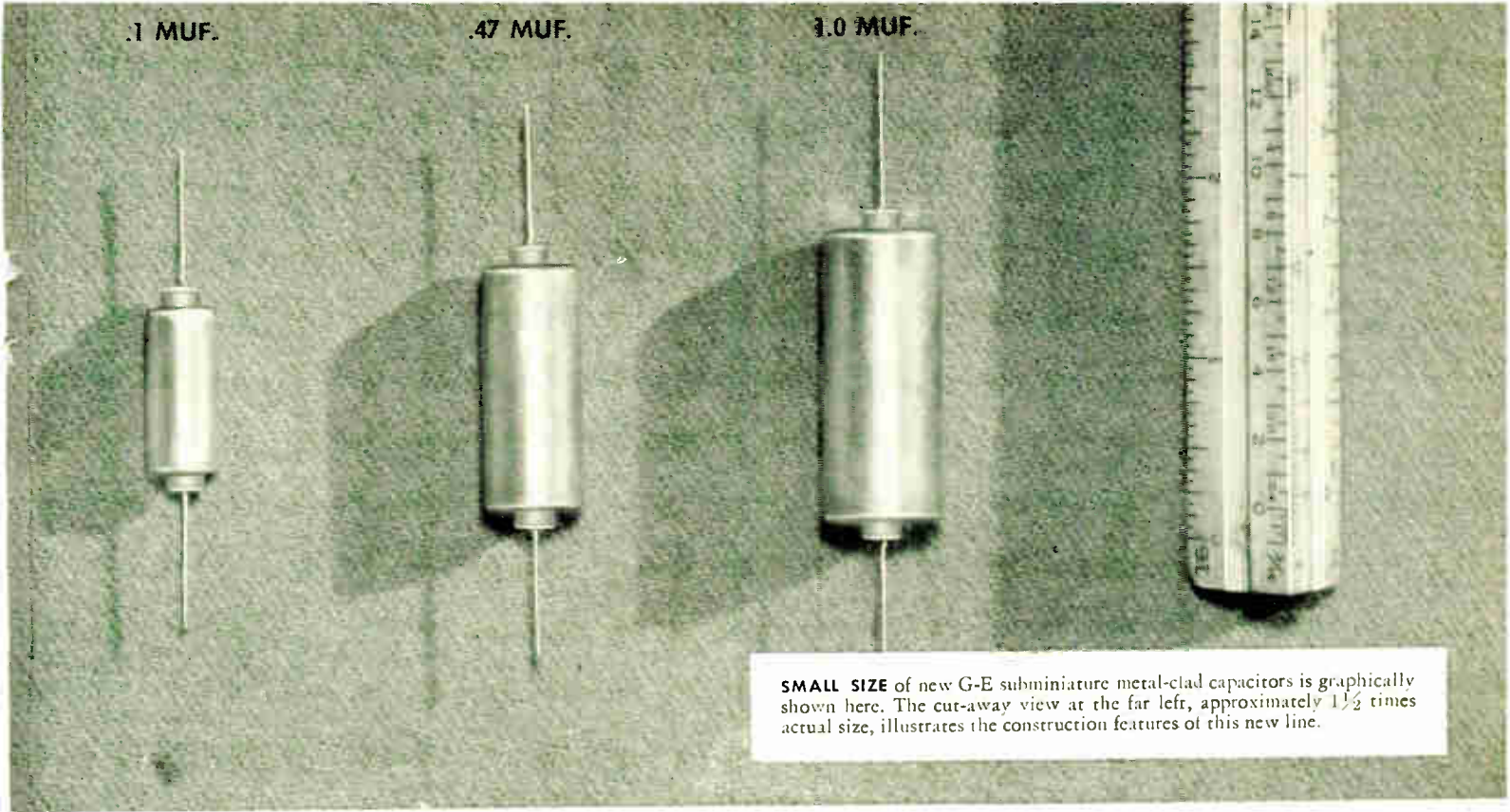

SMALL SIZE of new G-E subminiature metal-clad capacitors is graphically shown here. The cut-away view at the far left, approximately $1\frac{1}{2}$ times actual size, illustrates the construction features of this new line.

G-E SILICONE END SEAL

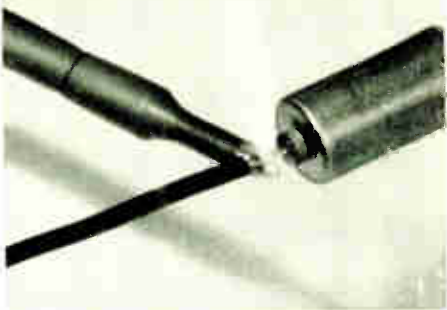

1. Solder right up to the case with new G-E silicone end seal—no need to waste $\frac{1}{4}$ inch of valuable space because of danger of cracking glass.

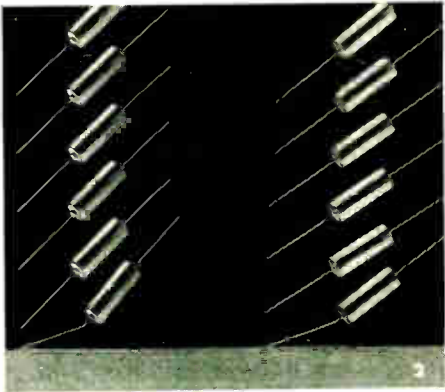

2. Withstands vibration and rough handling. This view shows a glass-bead-sealed capacitor and a silicone-sealed capacitor being dropped.



3. Undamaged by dropping, the two capacitors are shown here—note that there are no cracks in the G-E silicone-sealed unit.

4. At +125 degrees centigrade, the capacitor consistently maintains 100 percent capacitance.

5. At -55 degrees centigrade, the subminiature G-E metal-clad capacitor with Permafil dielectric shows less than 7 percent loss in capacitance.

6. Capacitance vs. temperature is shown by this typical curve. G-E capacitors with Permafil dielectric have very little capacitance change throughout the entire range from -55C to +125C.

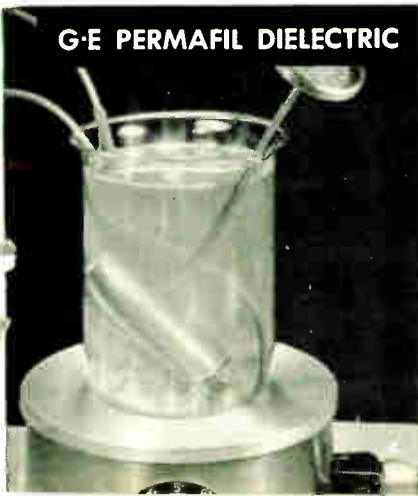

G-E PERMAFIL DIELECTRIC

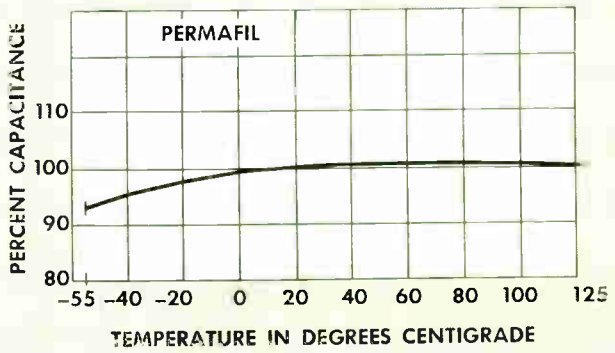



LABORATORY
FOR
ELECTRONIC
TUBES

Descriptive literature on Model 686 gladly sent on request. WESTON Electrical Instrument Corporation, 614 Frelinghuysen Ave., Newark 5, N. J.

WESTON
Instruments

WESTON

(686 Type 10A)

true mutual conductance

ELECTRONIC TUBE ANALYZER

(over-all Gm accuracy 3% or better)

Tests tubes under actual circuit operating potentials.

Tube characteristic operating curves can be plotted for comparison with manufacturer's specifications.

Transconductance can be measured directly without need for null adjustments or correction factors.

Voltage Ratio method of measuring transconductance meets the IRE Standard 50 IRE 7.S2 paragraph 7.2.2.4.

Completely self-contained with all necessary power supplies, meters and switching for performing short tests, static characteristic measurements and grid to plate transconductance measurements.

A well filtered d-c power source is supplied, making it possible to test tubes with d-c potentials which can be accurately adjusted to correspond to actual circuit voltage operating conditions.

Precision meter shunts and multipliers are wire wound to 0.5 per cent accuracy.

Special circuitry makes meter loading effects negligible.

Regulated grid bias supply keeps this most critical voltage constant. Plate and screen supplies do not affect grid bias setting.

Wide range of measurement of transconductance provides good readings on all tubes from small subminiature types to large power control types. The true transconductance is obtained on all triodes and pentodes, including low mu control tubes having plate resistance as low as 250 ohms.

Transconductance ranges are available in the following combinations of range and grid signal voltages:

Grid Signal	1.0	0.5	0.2	0.1	Volts
Gm x 1	300	600	1500	3000	Micromhos
Gm x 10	3000	6000	15000	30000	Micromhos

The Gm x 1 range is especially useful in the measurement of subminiature tubes having low transconductance.

Reliability, Dependability and Accuracy assured by sound engineering, skilled manufacture and high quality components.

7049

AT LAST... super dependable Aluminized Picture Tubes

**NOW
AVAILABLE**

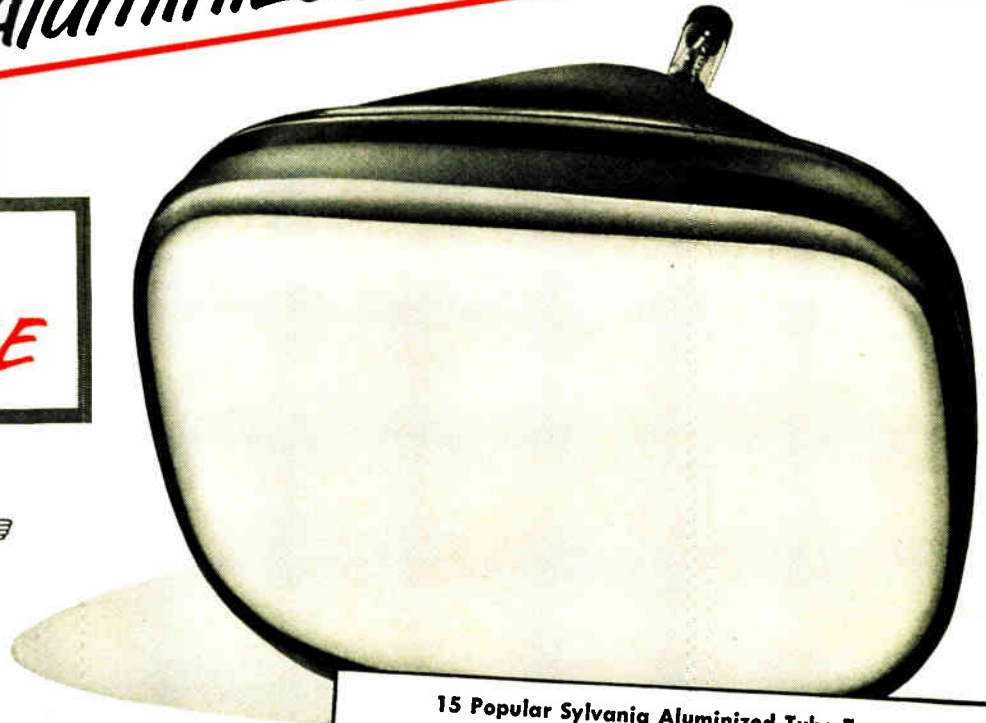

The name SYLVANIA on an Aluminized Picture Tube is an *endorsement of dependability!* It signifies that the tube has passed 781 quality-control tests, plus a series of final inspections after a 48-hour hold period.

Sylvania Aluminized Picture Tubes offer all these Advantages

1. **More Usable Light Output** resulting from reflection of wanted light from back of screen.
2. **Better Picture Contrast and Increased Contrast Range** due to elimination of reflected unwanted light from inside the tube.
3. **More Uniform Screen Color Tube for Tube** because of tighter screen color quality limits.
4. **Longer Screen Life** due to the protection of aluminum film on back of screen.
5. **Greater Picture Brightness and Sharpness** result from the elimination of electron "sticking."
6. **Longer Tube Life** due to a controlled degree of getter action in the aluminum film.

Lower Aluminized Picture Tube Prices!

Sylvania aluminized picture tube prices have now been reduced to slightly above regular television picture tube prices. Now you can offer your sets with 50% brighter pictures at practically no additional cost. For detailed data sheets drop a line to Dept. 4R-3105, Sylvania, today!

**15 Popular Sylvania Aluminized Tube Types
AVAILABLE NOW**

Type	Focus	Deflection		Ion Trap Magnet	Length
		Type	Hor. Angle		
17HP4	Lo Es	Mag	65°	S	
21ALP4A	Lo Es	Mag	85°	S	19 3/16"
21AMP4A	Mag	Mag	85°	S	20 7/16"
21EP4B*	Mag	Mag	65°	S	20 7/16"
21FP4C*	Lo Es	Mag	65°	S	23"
21WP4A	Mag	Mag	66°	S	23"
21XP4A	Lo Es	Mag	65°	S	22 1/4"
21YP4A	Lo Es	Mag	65°	S	22 1/4"
21ZP4B	Mag	Mag	65°	S	23"
24CP4A	Mag	Mag	85°	S	23 1/32"
24DP4A	Lo Es	Mag	85°	S	21 1/8"
24VP4A	Mag	Mag	85°	S	21 1/8"
27EP4	Mag	Mag	85°	S	21 1/8"
27LP4	Mag	Mag	85°	S	23 1/16"
27RP4	Mag	Mag	85°	S	24 23/64"
					23 1/16"

*Cylindrical Face. All others have Spherical Face Plates
Lo Es—Low Voltage Electrostatic
Mag—Magnetic
S—Single Ion Trap

SYLVANIA

Sylvania Electric Products Inc., 1740 Broadway, New York 19, New York

In Canada: Sylvania Electric (Canada) Ltd.
University Tower Bldg., St. Catherine St., Montreal, P. Q.

LIGHTING • RADIO • ELECTRONICS • TELEVISION

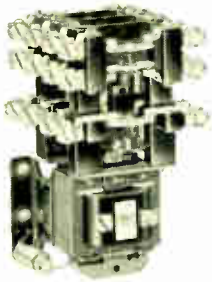

Type BX-840 A-C Relays

8 Normally open & 4 normally closed contacts.

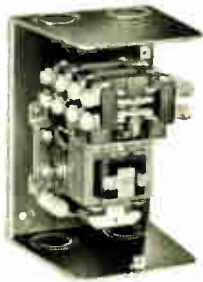

Type BX-44 A-C Relays

4 Normally open & 4 normally closed contacts.

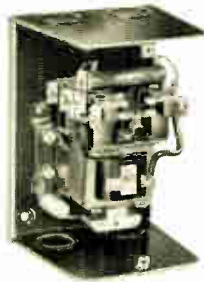

Type BA Thermostat Relays

For 3-wire gauge type thermostats with slow-moving contact elements.

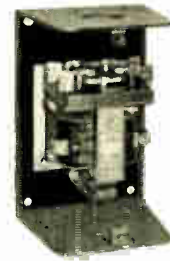

Type CL Low Coil Current Relays

For pilot controls, like oil burners or stokers, which can handle only small relay coil currents.



Hum-free Permanent Magnetic Type Relay

Requires no coil current to keep contact closed.

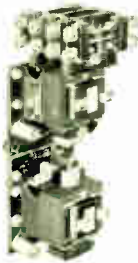

Hum-free Latch Relays

For quiet applications.



Bul. 849 Pneumatic Timers

Adj. 1/6 sec to 3 minutes.



Bulletin 709 Magnetic Starters

8 Sizes up to 300 hp, 220 v; 600 hp, 440-550 v.



Bulletin 848 Dashpot Timers

Adjustable from 2 to 30 seconds.



Large A-C Contactors

For applications up to 900 amperes—600 volts.

CONTACTORS • RELAYS • LIMIT SWITCHES • TIMERS

for Electronic Laboratories and Production Lines



Bulletin 802 Precision Limit Switches
Wide Assortment of Types & Ratings.



Bul. 802T Oiltight Limit Switches
Large variety of types.



Push Buttons—All Types and Sizes
Standard Duty—Heavy Duty—Oiltight.



Send for **ILLUSTRATED BULLETINS**

They are handy reference guides for electronic and plant engineers who design testing and automatic produc-

tion equipment. Write for bulletins. Allen-Bradley Co., 114 W. Greenfield Ave., Milwaukee 4, Wis.



ALLEN-BRADLEY
RADIO & TELEVISION COMPONENTS

QUALITY



TWO VIEWS SHOWING MECHANISM
ACTUAL SIZE

POWERFUL MOVING COIL MECHANISM HAS GYRO-LIKE STABILITY

The Marion Type MEP-1 meter mechanism was designed to develop highest possible torque for a given volume of magnetic material. Its high torque, heavy eddy current damping and low relative inertia provide unusual performance characteristics simulating the stability of a gyro, in like environment. Already it is setting new and higher standards for reliability in moving coil indicating mechanism design for aircraft application, where the influence of vibration and rapid attitude changes on pointer indication are significant factors.

The gyro-like stability of the MEP-1 mechanism results from its unique mechanical design. An end-pivoted coil assembly, with a one piece bearing shaft and precise mechanical assembly operates in a self-shielded magnet structure which produces approximately 6000 Gauss in a single air gap. When the end-pivoted moving coil, of long turning radius, operates in a magnetic field of such strength, substantial gains in torque and eddy current damping are realized. This great torque, combined with relatively light weight, permits unit bearing loadings substantially lower (i. e. larger pivot and jewel radii) than heretofore normal.

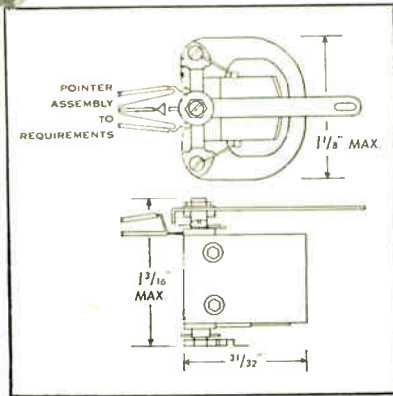
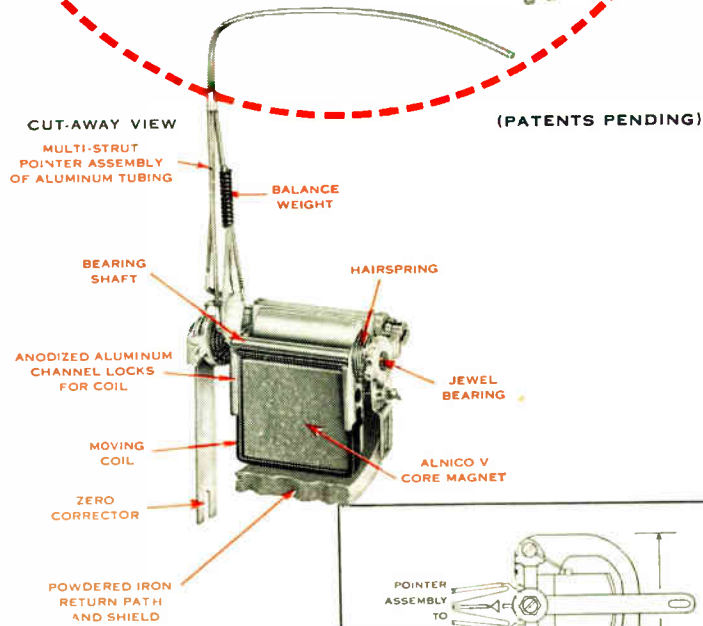

MECHANISMS BY MARION

Although developed expressly for application in aircraft navigational instruments, many of the MEP-1 characteristics make it desirable for use as the sensitive element in control devices where it is required to initiate a control function. It is one of a number of Mechanisms by Marion that extend the field of moving coil mechanism application where previously size, weight or performance characteristics prevented their use.

Marion Electrical Instrument Company,
407 Canal Street, Manchester, N. H.



Reg. U. S. Pat. Off.



marion meters

MANUFACTURERS OF RUGGEDIZED AND "REGULAR" METERS AND RELATED PRODUCTS

Copyright 1954 Marion

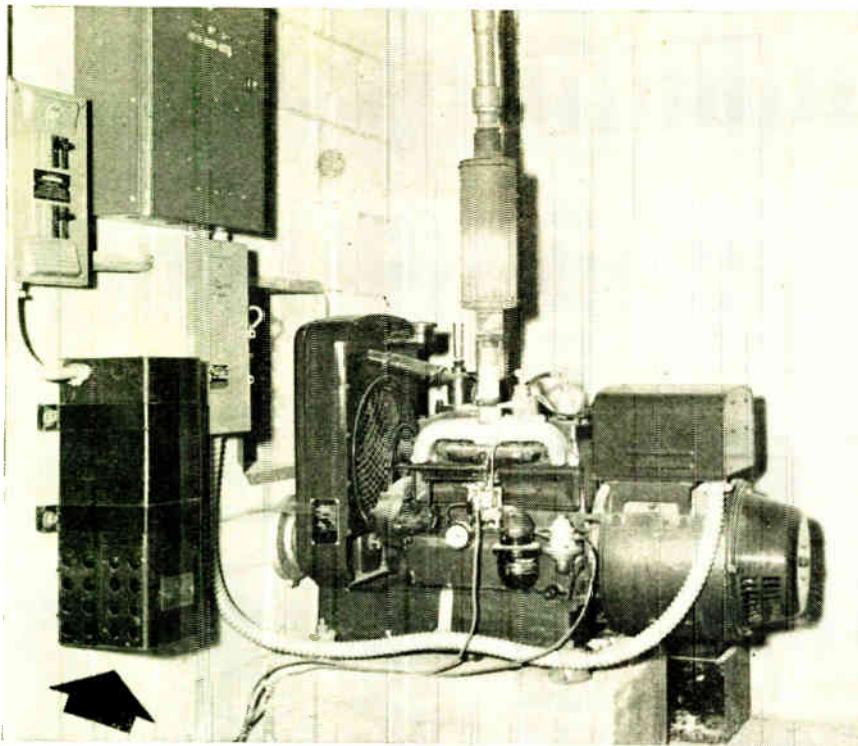

37 REPEATER STATIONS: The corner of a typical repeater station. The Sola Constant Voltage Transformer, which supplies stabilized voltage (regulated $\pm 1\%$ with line variations as great as $\pm 15\%$) to the equipment is identified by the arrow. The automatic, continuous, maintenance-free operation of the Sola units are important since many of the repeater stations are located in isolated sections and remotely controlled. The Sola stabilized voltage greatly contributes to the 20,000 hours or more life expectancy of the tubes used in the system, as well as aiding superior overall performance.

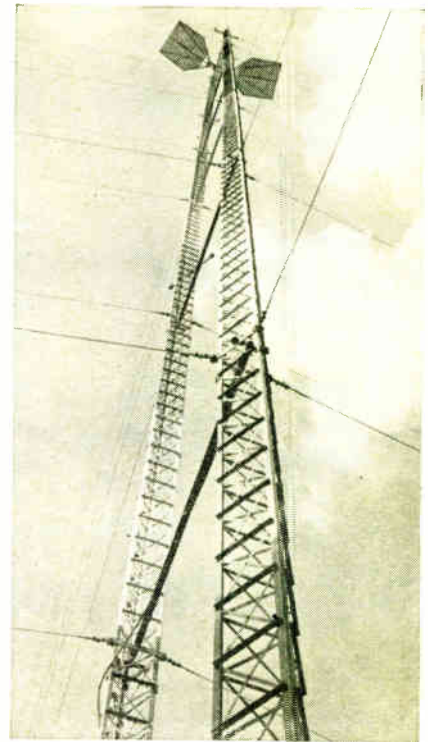

PASSIVE REFLECTORS: All of the Motorola radio equipment is installed on the ground. No cable, transmission line or waveguide runs are required on the tower for signal relaying. All radio frequency signals are directed through the air between the paraboloid antennas on the roof of the building and the 45° passive reflectors at the top of the tower.

Constant voltage power supply reduces maintenance and aids performance on microwave radio relay system

The Texas Illinois Natural Gas Pipeline Company's microwave radio relay system extends over 1,000 miles between Houston and Hungerford, Texas and Chicago, Illinois. This system utilizing Motorola equipment employs 37 repeater stations, many of them in remote, inaccessible locations.

Continuous, reliable operation of high quality is a basic requirement since the radio relay system is the nerve center of the entire pipeline operation. Sola Constant Voltage Transformers are installed at all 37 repeater stations and three terminal stations to assure a dependable source of stabilized voltage for the equipment.

Stabilized voltage contributes to superior performance of the electronic and electrical equipment by providing an operat-

ing voltage level constant to within $\pm 1\%$ with line voltage variations as great as $\pm 15\%$. In addition, operation of the electron tubes from a constant voltage source extends heater and filament life, greatly reducing tube replacement.

The Sola Constant Voltage Transformer is a static magnetic regulator that has no tubes or moving parts. Its operation is completely automatic and continuous with response time of 1.5 cycles or less.

You can select from 42 stock units; or custom-designed stabilizers can be manufactured to your specifications in production quantities. A Sola sales engineer will be happy to give you the facts on your request.

Automatic, Maintenance-Free Voltage Stabilization

SOLA *Constant Voltage*
TRANSFORMERS

New technical information is periodically being released on the application and operation of Sola Constant Voltage Transformers. If you are not presently receiving these informative bulletins, write requesting your name be placed on our mailing list.

Transformers for: Constant Voltage • Fluorescent Lighting • Cold Cathode Lighting • Mercury Vapor Lighting • Luminous Tube Signs
SOLA ELECTRIC CO., 4633 W. 16th Street, Chicago 50, Illinois, Bishop 2-1414 • NEW YORK 35: 103 E. 125th St., Trafalgar 6-6464
 PHILADELPHIA: Commercial Trust Bldg., Rittenhouse 6-4988 • BOSTON: 272 Centre St., Newton 58, Mass., Bigelow 4-3354
 CLEVELAND 15: 1836 Euclid Ave., Prospect 1-6400 • KANSAS CITY 2, MO.: 406 W. 34th St., Jefferson 4382 • Reps. in Other Principal Cities

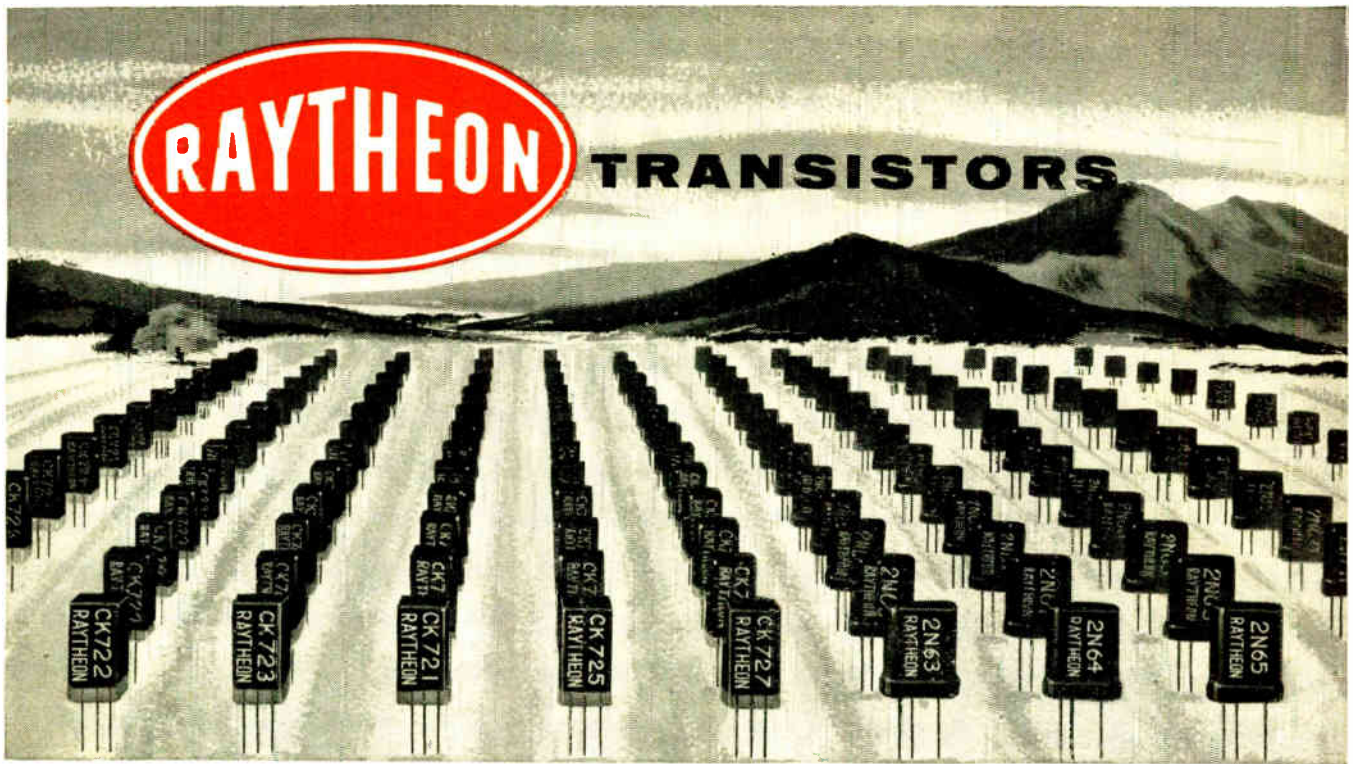

Foremost in the field

RAYTHEON TRANSISTORS are **FOREMOST IN THE FIELD** with **PROVEN RELIABILITY**. Over **1,000,000,000 OPERATING HOURS** of actual field performance in commercial equipment with only a **FRACTION OF 1% FIELD RETURNS** proves their reliability to be superior to the reliability of vacuum tubes.

RAYTHEON TRANSISTORS are foremost in number of units in use in commercial equipment. Raytheon successfully made transistors in "experimental," "pilot" and now **MASS PRODUCTION** phases. The latest continuous, mass production, and inspection techniques are employed in the making of Raytheon Transistors. **HUNDREDS OF THOUSANDS** are **IN ACTUAL COMMERCIAL USE** — **MANY TIMES MORE THAN ALL OTHER MAKES COMBINED**. No other manufacturers can make these statements.

RAYTHEON GERMANIUM DIFFUSED JUNCTION PNP TRANSISTORS

RATINGS: — ABSOLUTE MAXIMUM VALUES:	CK722	CK723	CK721	CK725	CK727	2N63*	2N64*	2N65*
Collector Voltage (volts)	-22	-22	-22	-22	-6	-22	-22	-22
Collector Current (ma)	10	10	10	10	10	10	10	10
Collector Dissipation (30°C) (mw)	33	33	33	33	30	33	33	33
Emitter Current (ma)	10	10	10	10	10	10	10	10
Ambient Temperature (°C)	50	50	50	50	50	50	50	50
AVERAGE CHARACTERISTICS (27° C)								
Collector Voltage (volts)	-6	-6	-6	-6	-1.5	-6	-6	-6
Emitter Current (ma)	1	1	1	1	0.5	1	1	1
Collector Resistance (meg)	2.0	2.0	2.0	2.0	2.0	2.0	2.0	2.0
Emitter Resistance (ohms)	25	25	25	25	50	25	25	25
Base Resistance (ohms)	250	350	700	1500	500	350	700	1500
Base Current Amplification Factor	12	22	45	90	35	22	45	90
Cutoff Current (approx.) (ua)	6	6	6	6	6	6	6	6
Noise Factor (max) (db)**	30†	25†	22†	20†	12††	25†	22†	20†



Excellence in Electronics

*Hermetically sealed in metal package
**In a one cycle band width at 1000 cycles

*Measured at $V_c = -2.5$ volts in common emitter circuit
††Measured at $V_c = -1.5$ volts; $I_c = 0.5$ ma in common emitter circuit

RAYTHEON MANUFACTURING COMPANY

Receiving Tube Division — Home Office: 55 Chapel St., Newton 58, Mass.

For Application Information Call: Boston, Bigelow 4-7500 • Chicago, National 2-2770 • New York, Whitehall 3-4983 • Los Angeles, Richmond 7-4321

RAYTHEON MAKES ALL THESE:

RELIABLE SUBMINIATURE AND MINIATURE TUBES • SEMICONDUCTOR DIODES AND TRANSISTORS • NUCLEONIC TUBES • MICROWAVE TUBES • RECEIVING AND PICTURE TUBES

Made to SURVIVE!



Miniature POWER Resistors

Carefully crafted for matchless performance, Dalohm miniature power resistors are made to survive the most severe environmental, shock, and vibration conditions.

Dalohm RH type resistors are completely welded from terminal to terminal. They are silicone sealed in a die-cast, black anodized radiator finned housing and mount on sub-panel for maximum heat dissipation.



25-Watt
Type RH-25

50-Watt
Type RH-50

Also Available RH-250—250 Watts
RS Types—2, 5, and 10 Watt

- Temperature coefficient 0.00002/Deg. C.
- Ranges from 0.1 Ohms to 55,000 Ohms, depending on type.
- Tolerance 0.05%, 0.1%, 0.25%, 0.5%, 1%, 3%, 5%.
- Manufactured in accordance to applicable JAN and MIL specifications.

Write, Wire or Call
1302 28th Ave. Phone 2139

DALE PRODUCTS, INC.

Columbus, Nebraska, U.S.A.

In Canada — Telefronics Corp., Ltd., Toronto and Montreal



News—New Products

These manufacturers have invited PROCEEDINGS readers to write for literature and further technical information. Please mention your I.R.E. affiliation.
(Continued from page 14A)

Tapped Delay Lines



Advanced Electronics Co., Inc., P.O. Box 394, Passaic, N. J., has six different types of tapped delay lines available: Type 6T1, Type 6T2, Type 6T3, Type 6T4, Type 6T5, and Type 6T6. Type 6T1 has a total time delay of 0.1 microsecond, 0.01 delay between taps, 75 ohms impedance, 32 mc cut off frequency and 0.01 microsecond maximum rise time. Type 6T2 has a total time delay of 0.25 μ s, 0.025 μ s delay between taps, 95 ohms impedance, 15 mc cutoff frequency, and 0.025 maximum rise time. Type 6T3 has a total time delay of 0.5 μ s, 0.05 μ s delay between taps, 190 ohms impedance, 6.2 mc cutoff frequency, and 0.05 μ s rise time. Type 6T4 has a total time delay of 1 μ s, 0.1 μ s between taps, 300 ohms impedance, 3.2 mc cutoff frequency, and 0.1 μ s rise time. Type 6T5 has between taps, 750 ohms impedance, 1.6 mc cutoff frequency, and 0.2 μ s maximum rise time. Type 6T6 has a total time delay of 5 μ s, 0.5 μ s delay between taps, 1000 ohms impedance, 620 kc cutoff frequency, and 0.5 μ s maximum rise time.

All the above instruments have ten taps each and their physical size is $6 \times \frac{1}{2} \times \frac{1}{2}$ inches.

Magnetic Deflection Yokes Catalog

Three new deflection yokes for military and oscilloscope applications are described in a new page of a catalogue now available from Syntronic Instruments Inc., 100 Industrial Road, Addison, Ill. Type Y15-5 is illustrated. Complete technical information is given, including dimensional drawing, electrical and mechanical data, and complete tables of push-pull and single-ended deflection coil data.

(Continued on page 26A)

ELECTROPLATED

Wires

Preferred for:

- Corrosion Resistance
- Better Solderability
- Suppression of Grid Emission
- Improvement of Electrical Characteristics

GOLD, SILVER, RHODIUM, PLATINUM and other metals, applied to many different types of wire to meet your specifications. Uniform plating, scientifically controlled. Write for latest list of products.



SIGMUND COHN MFG. CO., INC.
121 So. Columbus Avenue • Mount Vernon, N.Y.



ENTIRELY NEW



POWERSTAT Variable Transformers TYPE 136 AND 236

provide new higher ratings . . . smaller size . . . easier installation and servicing . . . smoother operation and longer life . . . greater overload characteristics.

POWERSTAT types 136 and 236 are all new . . . new design . . . new performance . . . new ratings. Incorporated into each unit are all the features essential for the ultimate in variable transformers. Types 136 and 236 are offered for manually-operated and motor driven duty in 120, 240, 480 volt ratings. Here are the reasons they are superior:

- **Higher Ratings:** Type 136 is rated 120 volts, 50/60 cycles input; 0-120/140 volts, 20.0 amperes output.
- **Smaller Size:** "Pancake" coil design provides compactness for bench or panel mounting.
- **Easier Installation:** Three sets of mounting holes suit all needs. Binding post type terminals provide all connection methods.
- **Easier Service:** Simply remove plate block for access to brush assembly. Brush easily removed and replaced.

and replaced.

- **New Radium Plated Commutator:** The one best answer to smooth performance and long life. The contact surface remains forever free of oxides. Corrosion is reduced. Uniform contact drop maintained and greater overload characteristics allowed.

There is a complete standard line of POWERSTAT variable transformers type 136 and 236 to suit individual requirements. Write for Bulletin P354.

**The SUPERIOR ELECTRIC
COMPANY**

Manufacturers of: Powerstat Variable Transformers
Stabilize Automatic Voltage Regulators • Volt-
box A-C Power Supplies • Powerstat Light
Dimming Equipment • Varicell D.C.
Power Supplies • Superior 5-Way
Binding Posts

THE SUPERIOR ELECTRIC CO.
1105 Clarke Ave., Bristol, Conn.

Please send Bulletin P354

Name.....

Title.....

Company.....

Address.....

INSTRUMENT Power Supply TRANSFORMERS

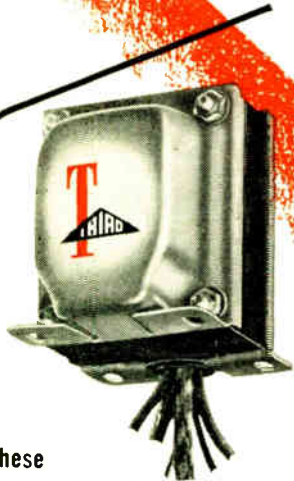

These transformers, developed by Triad especially for voltage regulated power supplies, cathode ray tube supplies, preamplifiers, and VT voltmeters, are among the more than

**50 NEW Items in
Triad's NEW 1954
Catalog**

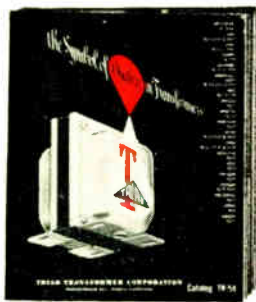

Write for your copy of Catalog TR-54
— it completely describes the
finest line of transformers
made.

T
TRIAD
TRANSFORMER CORP.
4055 Redwood Ave. • Venice, Calif.



News—New Products

These manufacturers have invited PROCEEDINGS readers to write for literature and further technical information. Please mention your I.R.E. affiliation.

(Continued from page 24A)

Impulse Counter Brochure

Kellogg Switchboard and Supply Co., 79 W. Monroe St., Chicago 3, Ill., has a new brochure which describes their new selector switch utilizing relay-type contacts. Applications include the fields of industrial control, computer design, vhf radio, microwave, selective signaling, and telemetering. The switches are designed to handle electrical impulses that are to be registered, stored, and released at a rate of 20 per second (under proper conditions).

Miniaturized 12-Channel Carrier System

Deliveries of new type 45A carrier telephone systems are now being made by Lenkurt Electric Co., San Carlos, Calif.

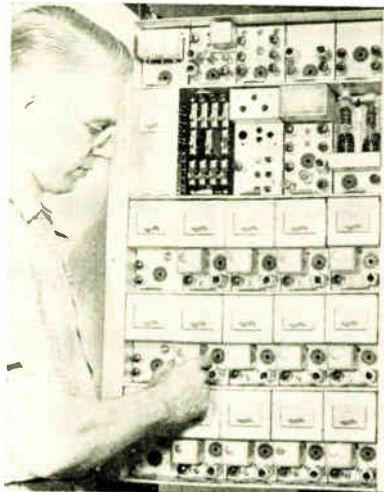

Providing up to 12 carrier-derived voice channels on an open wire line, Type 45A systems co-ordinate with systems such as Western Electric J and Lenkurt 42C. They can be installed on lines already equipped with carrier systems using frequencies up to 35 kc. Four staggered frequency allocations are available to permit installation of several systems on a single pole line.

All units for a complete 12-channel system plug into a prewired shelf which occupies 31½ inches on a standard 19-inch equipment rack. The shelf mounts through the rack, extending 5 inches to the front and 2 inches to the rear. Filters, hybrids, relays, and other interchangeable components plug into each equipment unit.

Sufficient gain and regulation are provided to permit repeater spacing of 170 miles in nonsleet areas. The system broadband regulator provides up to 48 db of flat loss correction at 99 kc and up to 24 db of slope correction between 99 and 150 kc. In addition, individual regulators in each channel will automatically compensate for up to 7 db of attenuation due to line absorption peaks or other irregularities.

(Continued on page 40A)

KAHLE

offers

NEW SERVICES

to you...

Over forty years of precision engineering experience is now available to you through new Special Experimental & Research Service facilities of Kahle Engineering Company. Kahle's cumulative knowledge springs from its pioneering successes in electronics and allied industries coupled with vast experience with the actual end products which its machines produce.

NEW SPECIAL EXPERIMENTAL & RESEARCH SERVICES FOR THE ELECTRONIC INDUSTRY.

- Special glass parts and accessories
- Special tools for research
- Special models
- Small-lot manufacture of special items for research or development
- Regular industrial engineering at regular fee or contract rates
- Special tubes, lamps, etc. for research purposes including elements and parts
- Any special equipment for manufacture or research for tubes or lamps

To take advantage of these new services, write Kahle today.

Kahle
ENGINEERING
COMPANY

1312 SEVENTH STREET
NORTH BERGEN, N. J.

©NTI

Hughes Diodes for Computer Applications

Types 1N191 and 1N192

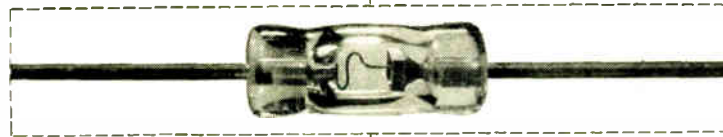

Actual dimensions
of diode body:
0.265" X 0.130"

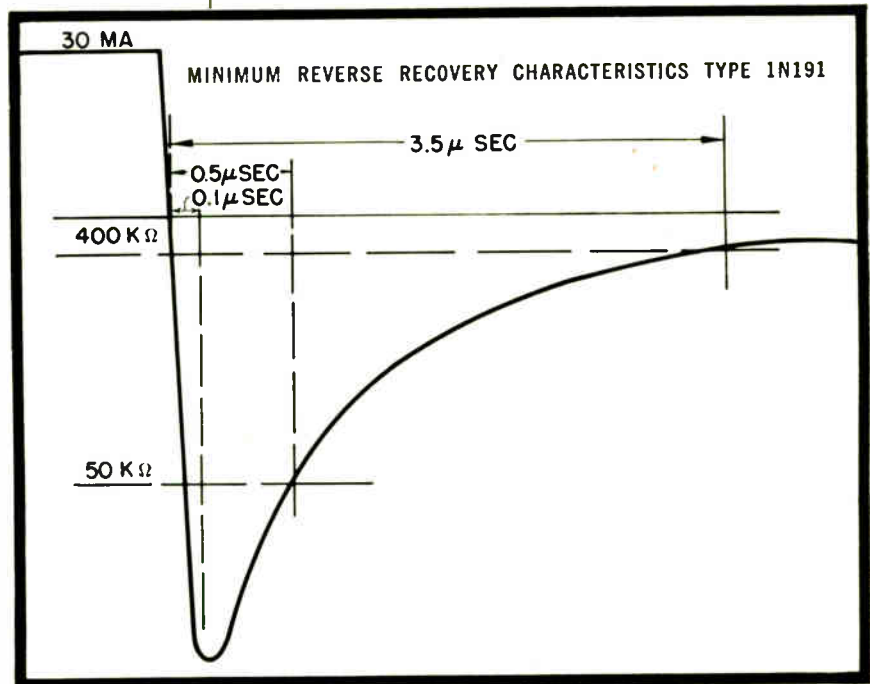

Recovery Time Characteristics

at 25° Centigrade

Type 1N191

50 K Ω @ 0.5 μsec and 400 K Ω @ 3.5 μsec maximum

Type 1N192

50 K Ω @ 0.5 μsec and 200 K Ω @ 3.5 μsec maximum

Maximum Back Current

at 55° Centigrade

Type 1N191

400 K Ω min. between -10 and -50V

Type 1N192

200 K Ω min. between -10 and -50V

To measure pulse recovery for both types, diodes are pulsed at 30 mA in the forward direction and then a back voltage of -35 volts is applied.

Now, as part of the continuing program to meet the expanding requirements for computer components, Hughes announces the registration of *Diode Types 1N191 and 1N192*. Both are selected for their outstanding performance in computer service.

These computer type diodes, like all Hughes diodes, are designed to ensure extremely high moisture resistance... thermal stability... electrical stability... subminiature size... thorough dependability. These features mean long life with minimum maintenance.

If you need special computer type diodes, chances are that we can furnish them on a production basis—because we are constantly producing and providing many types to meet literally hundreds of electronics and communications applications. Among these are high forward conductance, low-voltage diodes, used for certain computer applications.

Just Off the Press

A new, eight-page descriptive brochure. Lists and describes all the more widely-used RETMA, JAN and special types in the Hughes line. Just write for your copy of Bulletin SP-2.

SEMICONDUCTOR
SALES
DEPARTMENT

Hughes

Aircraft Company
Culver City
California



NEW YORK CITY CHICAGO

STABLE! ACCURATE!

CARBON DEPOSITED RESISTORS



... GLASS SEALED FOR LIFE

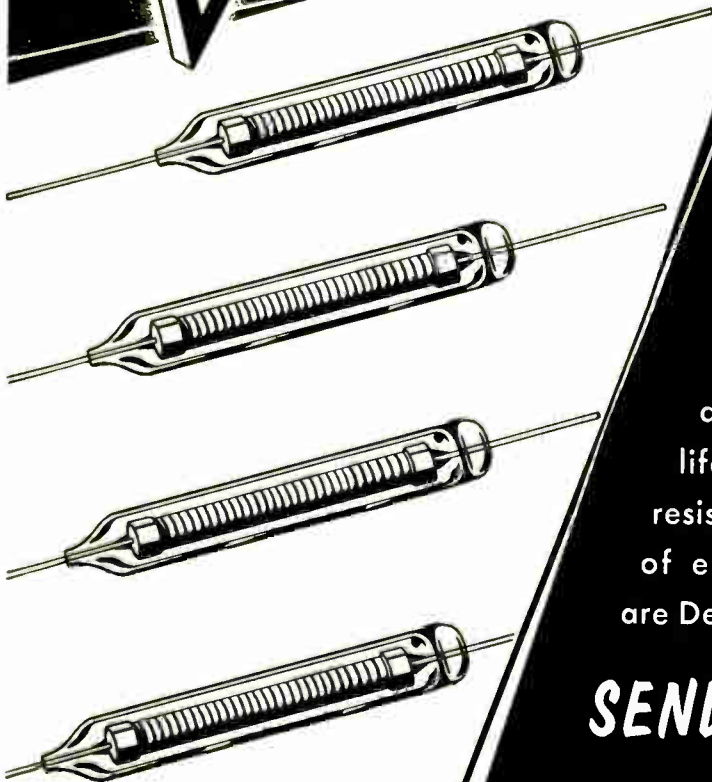
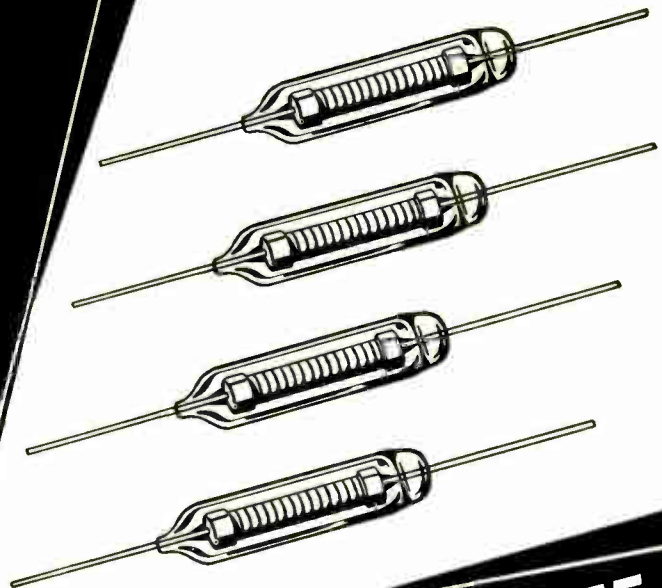

Stability and reliability are outstanding qualities of glass sealed resistors. Since Victoreen resistors are hermetically sealed in glass, they are permanently impervious to harmful effects from dust, fumes, gases and moisture and are fully protected from mechanical damage. Stability and reliability for life are insured by the glass seal. Such resistors are vital to perfect functioning of electronic devices. Two examples are Decade Boxes and Analog Computers.

SEND your inquiry to . . .

COMPONENTS DIVISION
The Victoreen Instrument Co.
3800 PERKINS AVE. • CLEVELAND 14, OHIO



silicon

ACTUAL SIZE



Now . . . long-awaited *silicon junction diodes* are available; developed by Texas Instruments, a leading transistor manufacturer. Operating temperatures up to 150°C are safe, offering a new degree of design freedom!



junction



New . . . extremely low back current characteristics, as low as 0.001 microamps at rated voltage. Glass-to-metal hermetic seals, of course. For more detailed information on these new silicon junction diodes — and on other new TI semiconductor products — write today.



diodes!



TEXAS INSTRUMENTS
INCORPORATED
6000 LEMMON AVENUE DALLAS 9 TEXAS



No cracks, please

You'll find no radial cracks in CTC terminal boards, or "cracked" rivet shanks on terminals. And there's a good reason for this.

Our swaging machines use tools that we designed ourselves in order to prevent just such damage. Terminals are fastened securely — and carefully. You benefit from a board that has no "weak spots" — that can give you the service you have a right to expect. And, of course, you also benefit from all the other quality control details that enable us to offer our customers *guaranteed* components — custom or standard. Coatings are smoothly applied — no wrinkles, no heavy deposits. C.T.C. terminals are made from certified stock that is free from defects. And the terminals themselves are guaranteed, even to the thickness of the coatings.

This C.T.C. quality control is given to all C.T.C. products including insulated terminals, coil forms, coils, swagers, terminals and capacitors. For all specifications and prices, write to

Cambridge Thermionic Corporation,
456 Concord Avenue, Cambridge 38,
Mass. West Coast manufacturers contact:
E. V. Roberts, 5068 West Washington Blvd.,
Los Angeles 16 and 988 Market St.,
San Francisco, California.

Terminal Board Data. CTC makes both standard boards and to your own specifications. Standard boards in cotton fabric phenolic, nylon phenolic or grade L-5 silicone impregnated ceramic. Custom made in cloth, paper phenolic, melamine, epoxy or silicone fibreglas laminates, imprinted as required and lacquered or varnished to specifications MIL-V-173 and JAN-T-152.



A wide variety of hardware is available at C.T.C. — all of it quality controlled and guaranteed for durability. This hardware includes terminal board brackets, standoff mounts, spacers, tube clamps, panel screws, thumb screws, dial locks, shaft locks, handles and handle ferrules.

CTC

CAMBRIDGE THERMIONIC CORPORATION

*makers of guaranteed electronic components,
custom or standard*



SAME PRICE . . . NEW PERFORMANCE!



HERMETICALLY SEALED Germanium Diodes

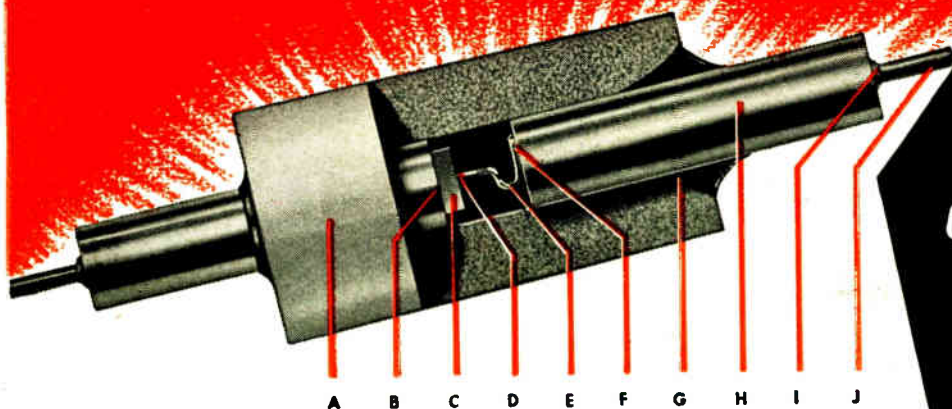

**SPECIAL
NON-POROUS
CERAMIC CASE!
GAS TIGHT!**

**JAN
TYPES**

IN General Electric, research aimed at product improvement never stops. And, here are the results of that effort...*a special, non-porous ceramic case diode plus perfection of a metal to ceramic seal!* This ceramic has already been successfully applied to seal high quality tubes. Used in G-E diodes, it voids gas contamination...adds many years of efficient performance!

Order the types you need *in quantity now!* Phone or write:
General Electric Co., Sec. X4854, Electronics Park, Syracuse, N. Y.

- A. Ceramic Case
- B. Solder
- C. Germanium Pellet
- D. Weld
- E. Platinum-Rhuthenium Whisker
- F. Weld
- G. Solder
- H. Nickel Pin
- I. Weld
- J. Leaded Copper Clod Wire



COMPLETE METAL TO CERAMIC SEAL. Gas-tight ceramic cases with metalized ends permit solder seal to nickel pins.

MOISTURE PROOF. These new diodes exceed the requirements of JAN humidity specifications.

REQUIRED ELECTRICAL PROPERTIES. More than two years of development were necessary to perfect this combination of hermetic seal and superior performance.

MECHANICAL STABILITY. Platinum-rhuthenium whisker is welded to the germanium pellet.

LONG-LIFE. The elimination of moisture effects adds years to the life of your equipment!

MAXIMUM RATINGS (At 25°C)

Hermetically Sealed DIODES	1N69	1N70	1N81*
Peak Inverse Voltage	75	125	50
Continuous Operating Inverse Voltage	60	100	40
Min. Forward Current (mA) at +1V	5.0	3.0	3.0
Max. Inv. Current (u a)			
At -50V	850	300	—
At -10V	50	25	10
AV Rectified Current (mA)	40	30	30
Peak Rectified Current (mA)	125	90	90
Surge Current (mA)	400	350	350

*JAN approval applied for

You can put your confidence in—

GENERAL  ELECTRIC

Frequency Meters

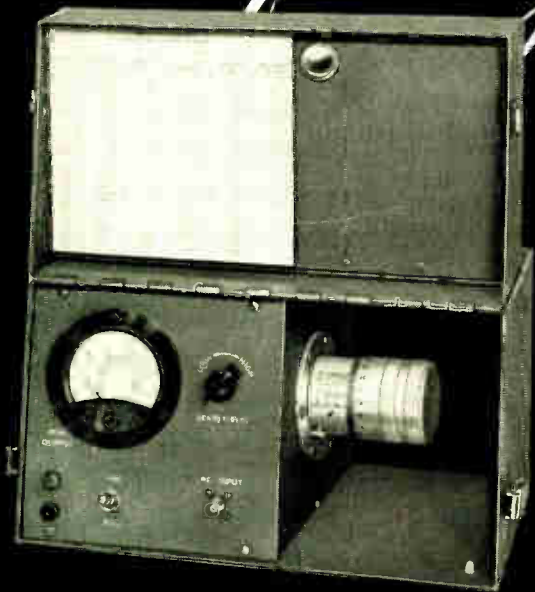

COMPLETELY
SELF-CONTAINED
FIELD TEST INSTRUMENTS

by

FREQUENCY STANDARDS

These precision-built field test instruments were designed by Frequency Standards to provide rapid and accurate means of frequency measurement in the field. Frequency is determined by means of a micrometer dial. This reading is translated to frequency by accurate individual calibration charts or curves. Transducers, fittings, and cables can be supplied to meet the requirements of customers and convenient storage space for these items is provided in the lid of the instruments.



MODEL	FREQUENCY RANGE	ACCURACY
912-4	900-1200 MC	.01%
1217-4	1200-1700 MC	.02%
1723-4	1700-2300 MC	.02%
4458-4	4400-5800 MC	.01%
5882-4	5800-8200 MC	.01%

ILLUSTRATED
BULLETINS
SENT ON
REQUEST

Frequency Standards
ASBURY PARK, NEW JERSEY

Address inquiries to
BOX 504



Famous Kings in History

FERDINAND V, 1452-1516, was the Spanish King of Castile and Leon. As Ferdinand II he was also King of Aragon. His policies, though severe, founded Spain's imperial greatness. He married Isabella of Castile. King Ferdinand is best-known to Americans because he and the Queen aided Christopher Columbus in his famed voyages of discovery.



In the field of electronics, industries all over America have discovered that they can always depend upon Kings Connectors for both standard and special applications. Because of the highest standards of manufacture, plus long experience, the Kings organization can meet your own specific connector requirements, whatever they may be. You'll be glad you called on Kings first.

UG-274/U

UG-290/U

UG-306/U

UG-88/U

FAMOUS KINGS CONNECTORS

BNC SERIES



KINGS *Electronics* CO., INC.
40 MARBLEDALE ROAD, TUCKAHOE 7, N. Y.

LITTON ENGINEERING NEWS



Model 3901 Thermopile

CONVENIENT NEW HIGH ACCURACY EQUIPMENT FOR MICROWAVE POWER MEASUREMENTS

The new Litton 3901 Thermopile offers unique convenience and accuracy in measuring rf power in microwave systems or monitoring temperature changes in cooling systems. In conjunction with rf water loads, it converts temperature differentials of flowing liquids into electrical energy which may be metered or recorded. With a water load of correct flow, average powers from 10 watts to several kilowatts may be measured quickly and precisely. For lower power levels, several thermopiles may be used in series.

Model 3901 employs 30 pairs of copper-advance junctions imbedded in a polyethylene cell. The cell is enclosed in a plastic case sealed with a Fairprene gasket and non-drying cement. The bottom plate is readily removed for servicing. Electrical connections are made through sealed banana plug jacks. Water connections are to 1/4" copper tubing through Uniflare fittings.

Internal resistance of the Thermopile is approximately 5 ohms. Voltage is approximately 1 millivolt per °C. Maximum pressure is 75 lbs. per square inch. The instrument measures 2" x 3" x 6"

long, and weighs 15 ounces. Price: \$75.00. (For further information, request Bulletin A-001.)

X Band Water Load



New Model 4105 Water Load is an efficient, low cost termination for X Band waveguide systems where power must be measured with extreme accuracy. Designed to operate with Litton 3901 Thermopile, Model 4105 covers the frequency range 7,000 to 10,000 mc. SWR is less than 1.2 full range. Maximum power is 1,000 watts cw and 300 kw peak power. Recommended water flow is approximately 1/4 gpm at 300 watts (with 2 mv, 100 µa, 19-to-22 ohm power meter and Litton 3901 Thermopile.)

Model 4105 consists of a glass tube centered vertically and running diagonally across a standard waveguide section. The glass section is terminated in Tygon plastic tubing fitted within Bake-

lite mounting blocks. The load employs a fixed probe with an UG-290/U BNC connector. Price: \$135.00. (For further information, request Bulletin A-023.)

Models 5500, 5501 Variable Phase Changers

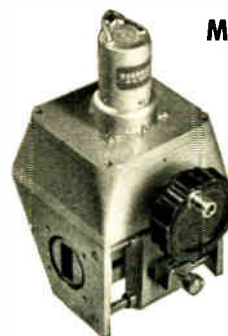

Model 5500 is a variable phase standing wave introducer designed for life-testing tubes, pulling figure measurements, etc., in 1 1/4" x 5/8" waveguide.

Model 5501 is a similar equipment designed for 1" x 1/2" X Band systems. Both are equipped for manual or motor drive; through a clutch, manual drive can override motor drive. Both models are offered in two speeds: a slow-speed 115 v 60 cps unit which moves the stub down the line approximately 180 electrical degrees and return 4 times per hour, and a fast 24 volt unit which moves the stub through a similar path approximately 15 times per minute. SWR is pre-set at 1.5 but may be adjusted to any value between 1.02 and 1.6. Both instruments will operate at power levels up to 175-200 kw peak, and are usable up to 225 kw. Average power rating is 500 watts. Price: \$300.00 with AC motor (slow); \$310.00 with DC motor (fast). (For further information, request Bulletin A-007.)

Data subject to change without notice. Prices f.o.b. factory.

2980



LITTON

ENGINEERING LABORATORIES

1049 BRITTAN AVENUE • SAN CARLOS 2, CALIFORNIA • U. S. A.

Manufacturers of glassworking lathes and attachments, vertical sealing machines, pumps, spotwelders and timers, burners, Melube, ball jars, hydrogen furnaces, thermopiles, ion gauges and amplifiers, U-lines, water loads, dielectric stubs, phase changers.



give your product a **BIG LIFT**
with
GUARDIAN
SOLENOIDS

NO. 1G A. C. SOLENOID

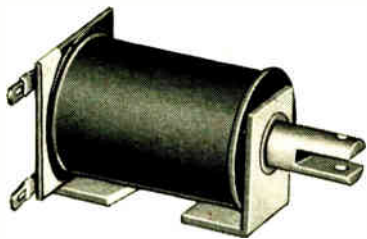

Yours—Guardian's New SOLENOID BULLETIN just off the press! Get your free copy describing the complete new Guardian line of AC and DC Solenoids (Continuous and Intermittent Duty) with Operating Data and dimensional drawings. Adjustable plunger strokes vary, to specification, from 1/16 inch up to 2 inches, lifting any required weight of less than 1 oz. up to 9 lbs. New, compact "Power Type" Solenoids feature laminated coils that provide a *big lift* for a positive, fast, full stroke. Guardian will gladly work with you on your experimental projects where solenoids are used singly or in combination with Steppers, Relays, Switches and other electrical components.

NO. 14 A. C. SOLENOID

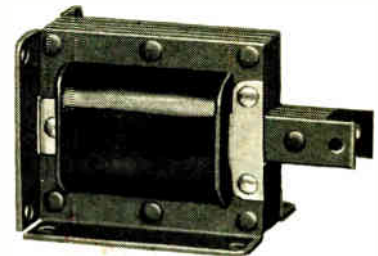

Adjustable Stroke in Inches	1/16	1/8	3/16	1/4	5/16	3/8	7/16	1/2	9/16	5/8
	Lift in Ounces	15	10	8	7	6 1/2	6 1/2	6 1/2	6	5 1/2
	Int. Duty Type									
	Cont. Duty Type	5 1/2	4	3	3	2 1/2	2 1/2	2 1/2	2	2

Adjustable Stroke in Inches	1/8	1/4	1/2	3/4	1	1 1/4	1 1/2
	Lift in Ounces	110	85	70	78	91	95
	Int. Duty Type						
	Cont. Duty Type	65	45	40	46	55	58

Volts 60 Cycles	Intermittent Duty Type		Continuous Duty Type	
	Ohms	Amps	Ohms	Amps
6	.42		1.25	
12	1.7		3.23	
18	3.23		7.53	
24	6.46		15.22	
36	13.1		37.5	
115	171.6	0.2	392.4	.074
230	675		1555	

Average power requirements } Intermittent duty type 27 V.A.
 } Continuous duty type 9.5 V.A.
 Wt. 3 1/2 oz.

SERIES M. A. S. STEPPER
 A compact dependable Add and Subtract unit. Up to 27 active points on total of 30. Rated at 10 steps per second. S.P.D.T. contact switch can be mounted on any ratchet position or on either magnet. Available to operate on 6 v. up to 115 v. A.C., 60 cycles, or from 6 v. 110 v. D.C.

Volts 60 Cycles	Intermittent Duty Type		Continuous Duty Type	
	Ohms	Amps	Ohms	Amps
6				
12			.24	5
18	.34	8.	.54	3.3
24	.56	6.	.94	2.5
36	1.0	4.4	1.7	1.8
117	11	1.4	18	.520
230	45	.73	93	.240

Average power requirements } Intermittent duty type 123 V.A.
 } Continuous duty type 43.6 V.A.
 Wt. 18 1/2 oz.



WRITE or wire today for your Free Copy of this New 8-Page Guardian SOLENOID BULLETIN "SOL-8" including the new Power Types.

GUARDIAN ELECTRIC
 1628-F W. WALNUT STREET CHICAGO 12, ILLINOIS
 A COMPLETE LINE OF RELAYS SERVING AMERICAN INDUSTRY

Visit
 Guardian's Booth
 No. 409
 Electronic Parts Show
 May 17-20
 Conrad Hilton Hotel
 Chicago



THE PORTLY PICKET PLANE

and how to magnify a precision system



One typical DV Development



COST-CUTTING FIXTURES

Maintaining precision tolerances on relatively short production runs is often a difficult problem involving costly tooling.

In a recent DV development, these costs have been chopped drastically by a series of new-type master reaming fixtures which eliminate jig-boring operations combined with time-consuming pre-assembly and alignment with special tools. In a single setup, the reaming fixtures (one of which is shown in the hands of a skilled DV tool-maker) perform all the finish boring operations on a cast-magnesium radar-antenna housing.

With this straightforward, routine technique, interchangeable parts are fabricated to near-zero dimensional limits.

If an airborne radar antenna makes you think of a small, intricate mechanism, take another look at the 29 by 20 by 7 foot radome hanging under this Air Force RC-121C radar picket plane—one of the giant early-warning Lockheed Super Constellations patrolling U.S. shorelines against attack. Inside, the Dalmo-Victor-developed antenna illustrated—the largest airborne antenna ever built—plays its part in extending the range of detection beyond 200 miles, horizon to horizon.

A primary engineering requirement, of course, was integration of this antenna system into the six tons of electronic equipment aboard the high-altitude reconnaissance ship: including weather radar, relay links for transmitting radar pictures to ground-control stations, and equipment for vectoring fighters or missiles onto targets.

Dalmo Victor's contribution of this antenna to the most powerful search radar equipment yet designed for aircraft, called for an application of all the skills and techniques developed during years of engineering light-weight precision electromechanical systems.

Whether your requirements call for the largest, the smallest, or something in-between; the design, development, and production facilities of Dalmo Victor's versatile organization can be put at your disposal.



DOWN-TO-EARTH ELECTROMECHANICAL ENGINEERING

Here's a CLARE RELAY

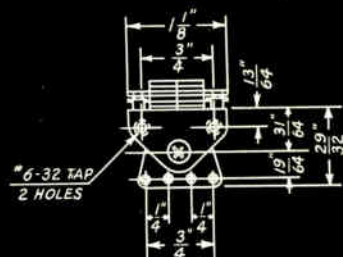
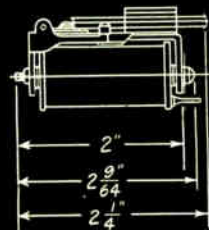
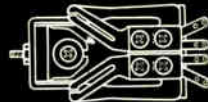
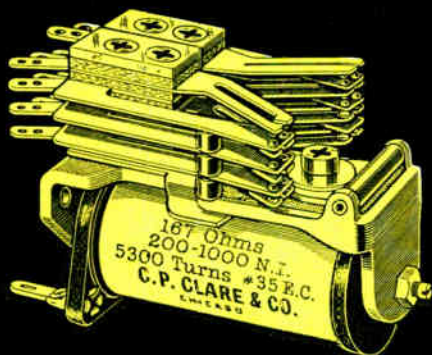

Compare these features of the CLARE Type J Relay with ordinary telephone-type relays

Extremely Small Size—Length: $2\frac{1}{4}$ " , Width: $1\frac{1}{8}$ " , Height (with 10 springs): $1\frac{3}{4}$ " , Net Weight: $2\frac{1}{4}$ oz. (approx.).

Large Current Capacity—Rated current carrying capacity: 4 amperes, 150 watts. Twin contact points (Palladium) standard.

Exclusive New Features—Twin contacts operate independently of each other—minimize chance of contact failure.

Largest possible bearing surface for hinge-type armature.

Armature bearing pin turns in cylinder of different metal which is full width of the heelpiece.

Heelpiece designed and processed for extreme rigidity to take and hold fine adjustments.

Versatile Operation—Standard coils provide for fast operate and fast release (minimum of 1 to 2 milliseconds). Coils may be provided for time delay on operation, time delay on release, or both. Also available, double-wound coils. Operating voltage up to 220 volts d-c.

Armatures may be single (right or left) or double. Residual: lock screw (adjustable) or fixed.

Relays may be mounted on mounting bases or strips as well as upon mounting bars and individual mounting brackets. Also available with plug-in mounting.

Available with slip-on dust-tight covers or hermetically sealed in metal enclosures.

that has changed a lot of design ideas

• No fully acceptable substitute has ever appeared for the conventional telephone type relay. It offers a versatility of performance and flexibility of installation that meet the requirements of the widest variety of industrial designs.

Prior to the introduction of the CLARE Type J Relay, however, designers were handicapped by the comparatively heavy weight, large size and certain operational limitations of this type of relay.

The CLARE Type J changed all this. Here, for the first time, was a light-weight, small-size relay of the telephone type. It not only gave comparable performance advantages but added certain exclusive features which offered a new conception of efficient, long-life relay operation.

This relay, among other features, provided *independent* twin contacts to preclude contact failures; the largest possible armature bearing surface, thus insuring stable operation and little adjustment change over a great number of operations; and an extremely rigid heelpiece to take and hold fine adjustments. (A fine adjustment will shift when a weak heelpiece is distorted by tightening the mounting screws.)

Acceptance of the CLARE Type J Relay has been phenomenal. It has replaced the old style telephone type relays in innumerable designs where small size and light weight were of prime importance. If you are not familiar with the features and characteristics of this relay, we invite you to contact your nearest CLARE sales engineer or write to: C. P. Clare Co., 3101 Pratt Blvd., Chicago 45, Illinois. In Canada: Canadian Line Materials Ltd., Toronto 13. Cable Address: CLARELAY. Write for Engineering Data Book.

CLARE RELAYS

FIRST IN THE INDUSTRIAL FIELD

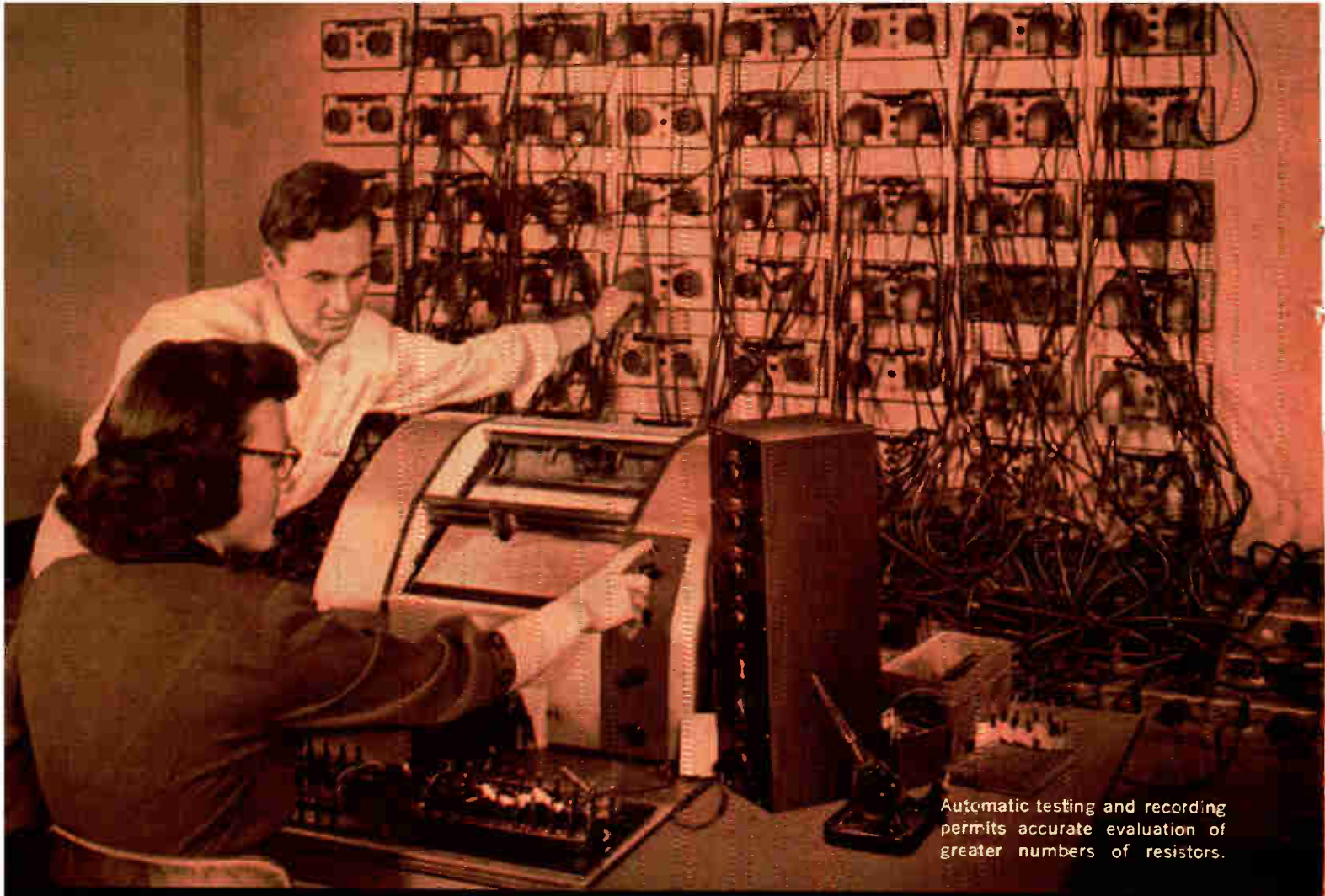

Automatic testing and recording permits accurate evaluation of greater numbers of resistors.

ONLY IRC MAKES SO MANY JAN AND

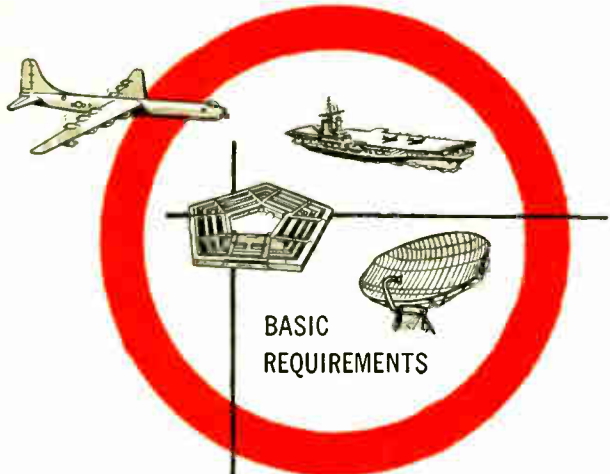

**BASIC
REQUIREMENTS**

JAN and MIL Specifications are basic guideposts for electronic advancement, whether used as engineering reference points or as procurement standards. IRC's dual emphasis on mass production and frequent, accurate performance testing assures you of the highest performance standards at the lowest possible cost.

56 different IRC resistors is today's figure—
all equivalent to JAN or MIL specifications. And all are standard units, available on excellent delivery cycle! If you manufacture end-equipment for the armed forces and must meet these specifications, or if you apply them as standards to your own requirements, depend on IRC for everything you need. For, manufacturing the widest line of resistors in the industry—127 different types in all—IRC is logically your best source of JAN and MIL type units.

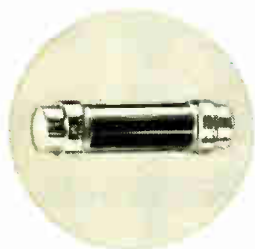

JAN-R-29 specification

For all requirements of JAN-R-29 Specification, Amendment 4, IRC sealed precision Voltmeter Multipliers function efficiently even when exposed to the most severe humidity. Used with 1-milliampere DC instruments, they enable voltage measurements to be made up to 6000 volts. Send for Bulletin.

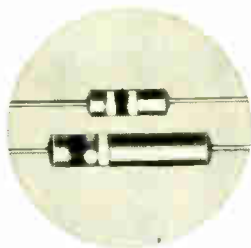

JAN-R-184 specification

Unusually stable and inexpensive, IRC BW Wire Wounds meet JAN-R-184 Specification, Amendment 5, at 1/2 and 1 watt. Resistance element is uniformly and tightly wound on insulated core. Molded housing provides full insulation. Widely used in meters, analyzers, high stability attenuators, low-power ignition circuits, etc. Send for Bulletin.



MIL-R-26B specification

For high power dissipation, IRC Power Wire Wounds meet every commercial requirement of MIL-R-26B Specification, Characteristic G. Tubular, flat, fixed, adjustable, inductive, non-inductive, lead, lug and ferrule types provide resistors for virtually any circuit. From 5 to 225 watts. Send for Bulletin.

MIL TYPE RESISTORS

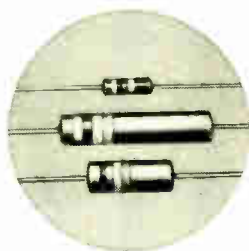

MIL-R-11A specification

IRC Advanced BT Resistors meet and beat MIL-R-11A Specification, Amendment 2. Filament-type resistance element and other exclusive features afford extremely low operating temperature and superior power dissipation in a compact, light, fully insulated unit. Available at 1/4, 1/2 and 1 watt to MIL specification and 2 watts to commercial specification. Send for Bulletin.

NEW

product



HERMETIC

sealing terminal



Overcomes limitations of other types of hermetic sealing terminals.



Molded KEL-F* body - chemically inert to organic solvents, acids, oils, fumes



Rugged construction - tough and resilient; withstands constant vibration.

Type HS-1 Feed-Thru Terminals provide assured hermetic sealing for electrical and electronic components. Exclusive IRC welding Technique bonds KEL-F* to metal in a superior seal. Designed to the sealing requirements of MIL-T-27. Send coupon for full data.

*Trademark - M. W. KELLOGG CO.

Boron & Deposited Carbon Resistors • Power Resistors • Voltmeter Multipliers • Low Wattage Wire Wounds • Insulated Composition Resistors • Volume Controls •

Wherever the Circuit Says

Precision Wire Wounds • Ultra HF and Hi-Voltage Resistors • Selenium Rectifiers • Insulated Chokes • Hermetic Sealing Terminals •



World Radio History

INTERNATIONAL RESISTANCE CO.

405 N. Broad St., Philadelphia 8, Pa.

In Canada: International Resistance Co., Ltd., Toronto, Licensee

Send me data on MF Voltmeter Multipliers, BW Resistors, Power Wire Wounds, Advanced BT Resistors, HS-1 Terminals.

Name _____

Title _____

Company _____

Address _____

City _____ Zone _____ State _____

TECHNOLOGY INSTRUMENT CORP.

TYPE 324-A VIDEO PHASE METER

This instrument of laboratory precision makes possible the rapid and accurate measurement of phase angle THROUGH THE VIDEO RANGE. It provides verification of design calculations, a criterion for optimum adjustment of delicate phase relationships, or a maintenance checking tool in the wide-band electronic system in modern use.

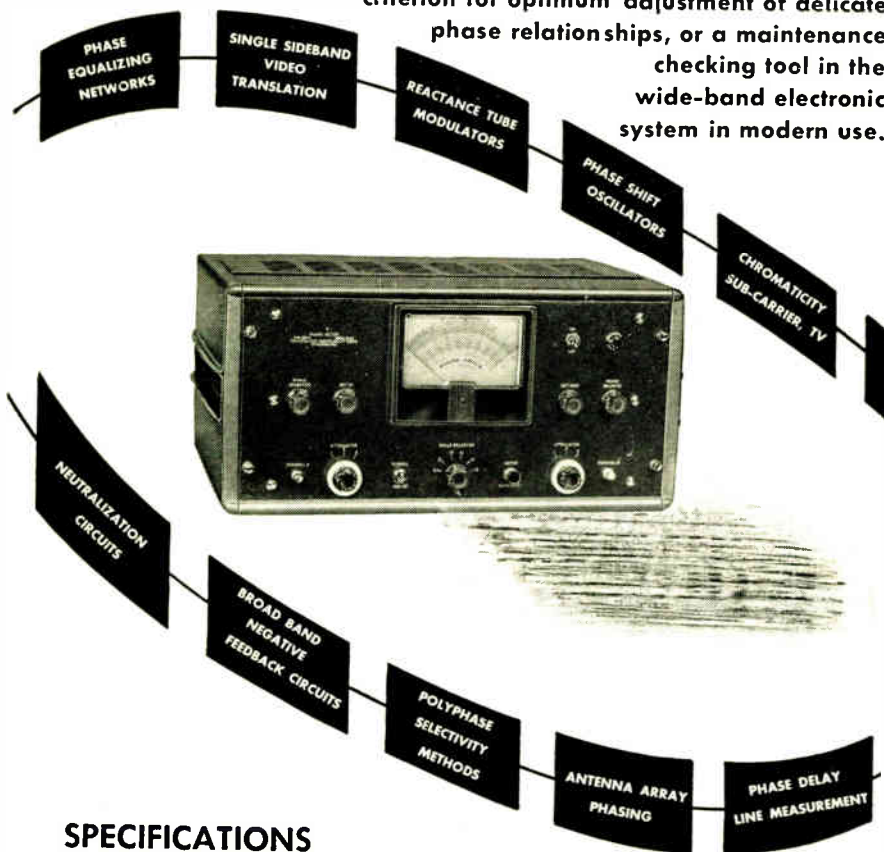

SPECIFICATIONS

- METER RANGES:** Phase angles from 0° to 360° full scale; and 90° quadrants full scale; no ambiguity.
- FREQUENCY RANGE:** 20 Kc. to 4.5 Mc. — Range down to 20 cycles may be supplied on special order.
- WAVEFORMS ACCEPTED:** Sine waves and any complex waves having not more than one positive-going zero axis crossing per cycle. Phase angle measurement is defined as phase difference between corresponding positive going zero axis crossings of the periodic signals being compared.
- AMPLITUDE RANGE:** 2 volts to 300 volts peak.
- ACCURACY:** ± 4° on quadrant scales. Incremental change of 0.25° is easily read.
- INPUT IMPEDANCE:** 10 megohms shunted by 14 mmf.
- FULL DETAILS UPON REQUEST

TECHNOLOGY INSTRUMENT CORP.

535 MAIN ST., ACTON, MASS., ACTon 3-7711

News—New Products

These manufacturers have invited PROCEEDINGS readers to write for literature and further technical information. Please mention your I.R.E. affiliation.

(Continued from page 26A)

Capacitor For Amateur Service

Jennings Radio Manufacturing Corp., P.O. Box 1278, San Jose 8, Calif. has introduced a new vacuum variable capacitor designed for service in the amateur field.

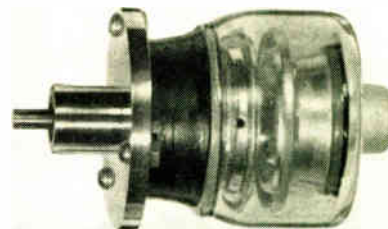

The Type VAC has a capacity range of 4 to 40 μf with a nonlinear variation that makes tuning possible at the low capacity end. Its rating of 42 amperes, rms at 10 kv peak (and 22 mc) also makes it useful as a neutralizing capacitor in commercial applications. The voltage rating of 10 kv peak is determined at maximum capacity and increases rapidly as the plates are separated at lower capacities. The unit is 5 inches long and 2 $\frac{3}{8}$ inches in diameter, with a $\frac{1}{4}$ inch-diameter tuning shaft.

Temperature Detector

A new, hermetically sealed, electrical resistance temperature detector with a fast response time has been announced by Thomas A. Edison, Inc., Instrument Div., West Orange, N. J.

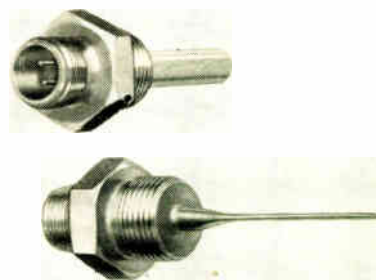

Designed for use with temperature recording, indicating, and control equipment where fast response is a primary requirement, the detector has an exponential time-control of 0.8 second or better in an agitated water bath.

Sealed in a stainless steel housing with a glass-to-metal sealed base through which the electrical connection is made, the new detector offers maximum resistance to corrosion and is not affected by most forms of destructive radiation.

Its useful temperature range is from -70°C to +200°C. Temperature accuracy is ±1.0 per cent or better in mid-scale region. The sensing element is a nickel winding having a basic resistance of 90.38 ohms at 0°C.

(Continued on page 52A)

K-CAPS[®]

Made by the makers of K-TRANS

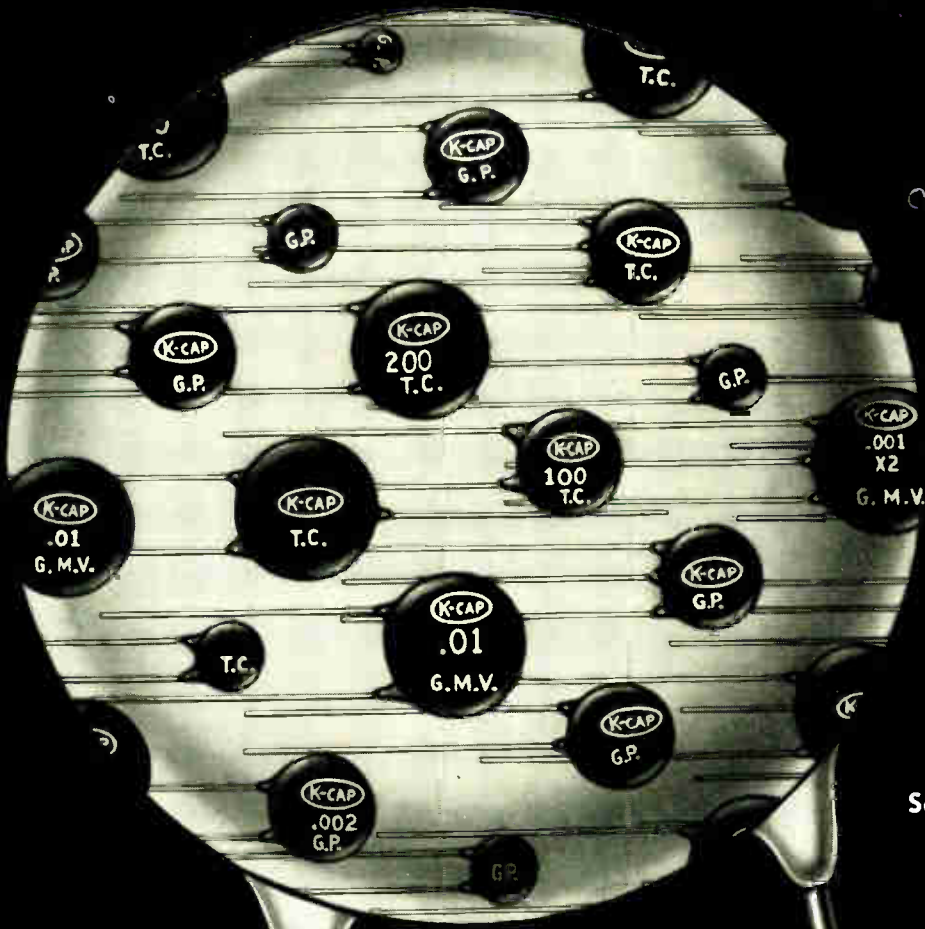

Specify the K-CAP
wherever you
use capacitors.
Temperature
Compensated,
General Purpose,
and Guaranteed
Minimum Value.
Samples available.



MASS PRODUCERS OF
ELECTRONIC COMPONENTS

AUTOMATIC
MANUFACTURING
CORPORATION

65 GOVERNEUR ST., NEWARK 4, N. J.

BORG... NEW STANDARD

for precision multi-turn potentiometers



BORG MICROPOTS

MODELS 901-903 TEN-TURN POTENTIOMETERS

Designed for the utmost versatility and adaptability, Borg Micropots eliminate the need for special design. New Standard Borg Micropots are available in single or double shaft models with exceptionally rigid servo-mount or bushing-mount at either or both ends.

- One-piece centerless-ground stainless steel shaft
- One-piece lead-screw and servo-mount permits rigid mounting and maintains true shaft alignment
- Servo or bushing mountings of exceptionally rigid design available at either or both ends of any 900 series Micropot
- Drive assembly gives higher accuracy in the four basic types of linearity without additional modification
- Contact carrier assembly design permits no backlash between shaft rotation and electrical rotation
- Coupling band provides accurate alignment between mounting surface and housing
- 49" Kohlrausch wound resistance helix permits finer resolution
- Dual Spring contacts assure accurate transmission of voltages from carrier assembly to terminal

MODELS 931-935 THREE-TURN POTENTIOMETERS

All potentiometers are available with double end support to assure efficient operation where subjected to excessive vibration. Precision ball bearings and precision rolled lead-screw provide higher accuracies and longer life. Ganged units are accurately phased before coupling.



901B



931SK



902SS



933SS



903BK



935BB



BORG EQUIPMENT DIVISION
THE GEORGE W. BORG CORPORATION
JANESVILLE, WISCONSIN



MICROWAVE SIGNAL GENERATORS

Complete coverage of
the range 950-10,800 mcs/sec.

with Polarad single dial operation

Four new Microwave Signal Generators covering the range 950-10,800 mcs/sec. All with famous Polarad single dial operation. Each provides the maximum working range possible in one compact signal generator. And, additional Polarad Signal Generators are available to cover 12.8 to 39.7 kmc.

These features on all MSG units assure fast and simple operation: direct reading, single dial frequency control that tracks reflector voltages automatically . . . direct reading attenuator dial . . . conveniently placed controls, in logical sequence . . . high visibility on the face of each instrument.

Polarad Signal Generators are built to the same high standards required for military equipment. They are practical for the factory assembly line—engineered ventilation assures continuous and stable operation of all instrument functions. Components are readily accessible for easy maintenance. And laboratory accuracy is guaranteed under the most rigorous operating conditions.

Write directly to Polarad or your nearest Polarad representative for details.

	MSG-1	MSG-2	MSG-3	MSG-4*
Frequency Range	950-2400 MCS/sec.	2150-4600 MCS/sec.	4450-8000 MCS/sec.	6950-10,800 MCS/sec.
(Frequency set by means of a single directly calibrated control)				
Frequency Accuracy	±1%	±1%	±1%	±1%
Power Output	1 MW	1 MW	.2 MW	.2 MW
Attenuator Range	120 db	120 db	120 db	120 db
Attenuator Accuracy	±2 db	±2 db	±2 db	±2 db
Output Impedance	50 ohms	50 ohms	50 ohms	50 ohms
Input Power	115V±10% 60 cps	115V±10% 60 cps	115V±10% 50-1000 cps	115V±10% 50-1000 cps
Internal Pulse Modulation:	0.5 to 10 microseconds 3 to 300 microseconds 40 to 4000 pulses per second Internal or external, sine wave or pulse			
Pulse Width				
Delay Rate				
Synchronization				
Internal FM:	Linear sawtooth 40 to 4000 cps Internal or external, sine wave or pulse			
Type				
Rate				
Synchronization	±2.5 MCS	±2.5 MCS	±6 MCS	±6 MCS
Frequency Deviation				
External Pulse Modulation:	Positive or Negative 40 to 4000 pulses per second 0.5 to 2500 microseconds (For multiple pulses) 1 to 2500 microseconds			
Polarity				
Rate				
Pulse width				
Pulse separation				
Output Synchronizing Pulses:	Positive, delayed & undelayed 40 to 4000 pps Greater than 25 volts Less than 1 microsecond			
Polarity				
Rate				
Voltage				
Rise time				
Size Approx. weight	17" long x 13¼" high x 15½" deep 60 lbs.		17" long x 15" high x 19½" deep 100 lbs.	

*Also available—MSG 4A: 6,950—11,500 MCS/sec.

"THE FINEST SIGNAL GENERATORS OF THEIR KIND"

Polarad

ELECTRONICS CORPORATION 100 METROPOLITAN AVENUE,
BROOKLYN 11, NEW YORK

REPRESENTATIVES Albuquerque • Arnprior, Canada • Atlanta • Boston • Chicago • Cleveland • Fort Worth • Kansas City • Los Angeles • New York • Philadelphia • San Francisco • Seattle • St. Paul • Syracuse • Washington, D. C.

PROCEEDINGS OF THE I.R.E. May, 1954

43A

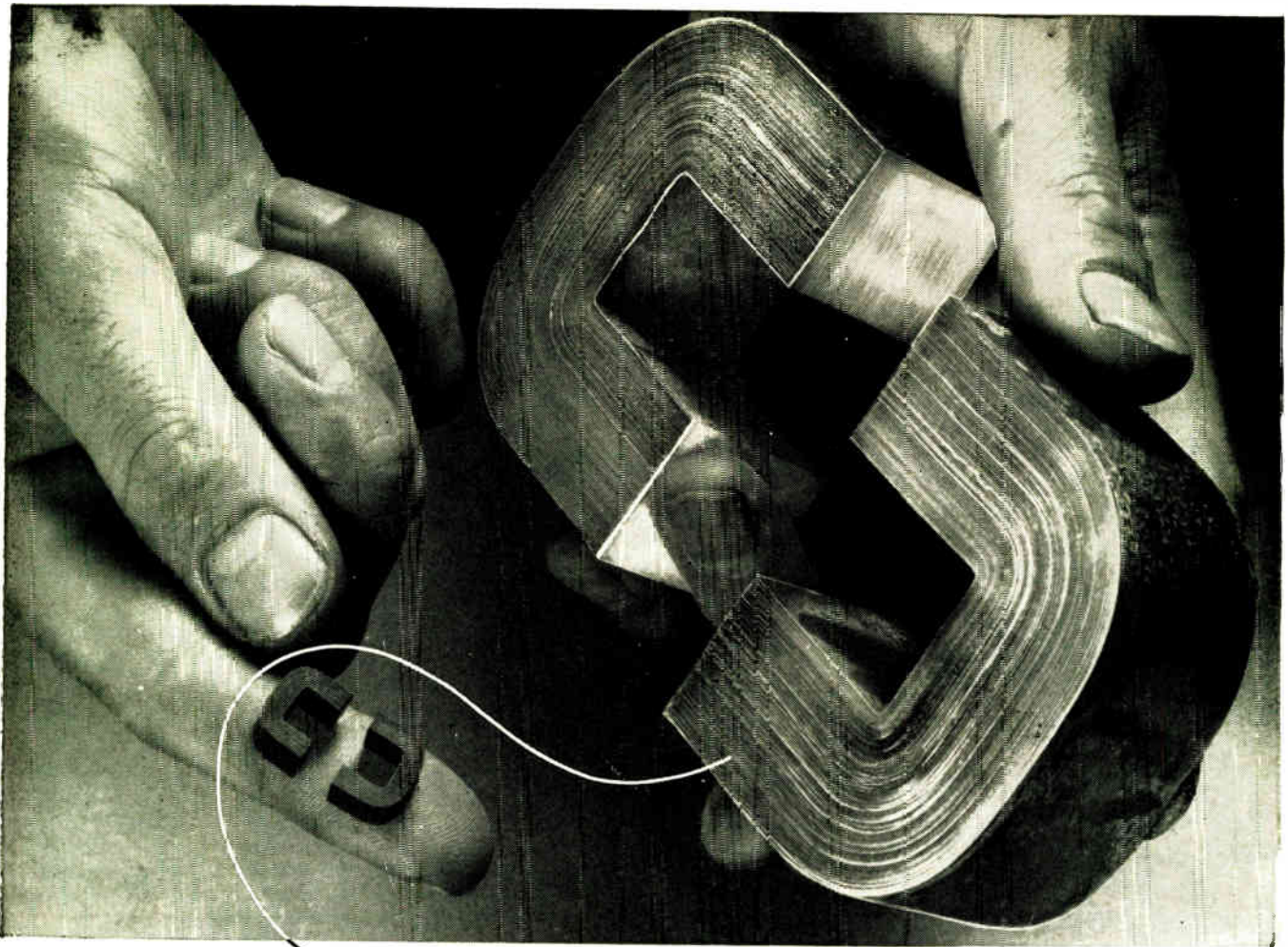

SILECTRON C-CORES... **BIG** or LITTLE

...any quantity and any size

*Wound from
precision rolled
oriented silicon
steel strip as thin
as .00025"*

For users operating on government schedules, Arnold is now producing C-Cores wound from 1/4, 1/2, 1, 2, 4 and 12-mil Silectron strip. The ultra-thin oriented silicon steel strip is rolled to exacting tolerances in our own plant on precision cold-reducing equipment of the most modern type. Winding of cores, processing of butt joints, etc. are carefully controlled, assuring the lowest possible core losses, and freedom from short-circuiting of the laminations.

We can offer prompt delivery in production quantities—and size is no object, from a fraction of an ounce to C-Cores of 200 pounds or more. Rigid standard tests—and special electrical tests where required—give you assurance of the highest quality in all gauges. • *Your inquiries are invited.*

THE ARNOLD ENGINEERING COMPANY

SUBSIDIARY OF ALLEGHENY LUDLUM STEEL CORPORATION

General Office & Plant: Marengo, Illinois

DISTRICT SALES OFFICES . . . New York: 350 Fifth Ave.

Los Angeles: 3450 Wilshire Blvd.

Boston: 200 Berkeley St.



W&O 4363



HERE OR ABROAD

**It's Wilcox VOR
For Improved Safety and Regularity of Operation
Under Adverse Weather Conditions**

Complete stations are available with 50 or 200 watts output, single or duplicated, manual or automatic changeover, local or remote control.

Wilcox supplies the prefabricated shelter, antenna and all electronic equipment—nothing else to buy.

Two years of engineering development has made possible a VOR of extreme accuracy and reliability, meeting all provisions of ICAO, Annex 10.

The Wilcox design offers low initial cost, rapid installation and minimum maintenance.

Write now for our technical data and full information.

wilcox

ELECTRIC COMPANY, INC.

Fourteenth & Chestnut
Kansas City 27, Missouri, U.S.A.

Any way you look at it...

★ Excellent color fidelity. Special Masking Amplifier plus overall quality of system results in superlative reproduction.

★ Continuous film movement. No intermittent action. Optical immobilizer eliminates claws and shutter.

★ Film may be run forward or backward. Stopped at any point. Speed may be varied.

★ Sensitivity of system faithfully reproduces all tonal gradations through gamma-corrected amplifier.

★ No shading adjustments necessary. Picture free from edge flare and shading. Completely automatic from remote panel.

★ Entirely new standard of operating economy for both color and monochrome operation.

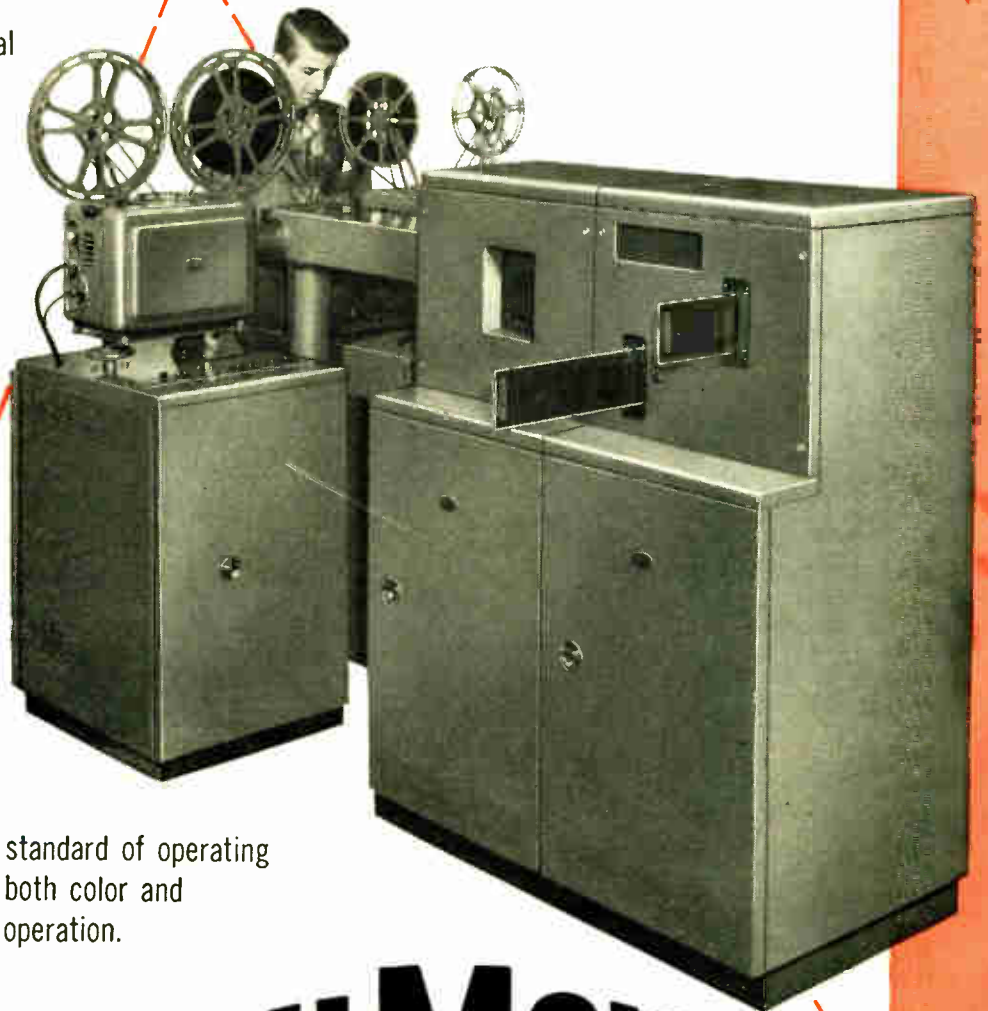

DU MONT®

YOU'RE YEARS AHEAD with the DUMONT COLOR MULTI-SCANNER

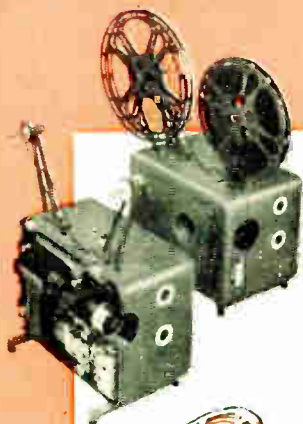

Here is the one system that puts you years ahead . . . whether for monochrome or color. The Du Mont Color Multi-Scanner permits you to be ready for the day you start color broadcasting, and at the same time provides a means of monochrome-film, slide and opaque pickup surpassing all other systems in quality of performance, operating economies and dependability. Yes, sir . . . anyway you look at it . . . you're years ahead with the Du Mont Color Multi-Scanner — the **only** continuous-motion scanner now being delivered commercially!



... FOR COLOR

16 mm. COLOR FILM



COLOR TRANSPARENCIES

Permits the average television station to prepare for color now, without the large investment required in specialized color equipment. The cost of the system may be amortized over both current monochrome broadcasting operations and future color operations.

The Color Multi-Scanner eliminates registration and other technical problems inherent in triple pick-up tube camera designs. The single scanning tube along with the unparalleled sensitivity of the Du Mont Multiplier Phototube results in a color signal source far surpassing that of other systems.

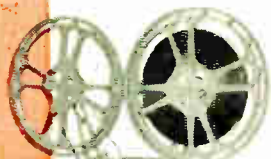

... FOR MONOCHROME



16 mm. FILM
MONOCHROME

The Color Multi-Scanner can go right to work on monochrome transmission. Utilization of the same equipment provides fine quality black and white reproduction. At the flick of a switch—your choice of color or monochrome—it's as simple as that!

The Color Multi-Scanner is basically the same as the famous Monochrome Multi-Scanner with the exception of a light-splitting mirror system and additional unitized channel amplifiers. All operational advantages and economies have been retained.



MONOCHROME
TRANSPARENCIES

... AND OTHER DUMONT COLOR EQUIPMENT



MONOCHROME OPAQUES

Incorporated in the Du Mont Color Multi-Scanner and available as a separate unit for improving other color signal sources, the Du Mont Color Masking Amplifier adds new realism to color signals. It permits compensation for dye and filter deficiencies and adds new qualities to any color setup.

Get details on the complete line of Du Mont color transmitting accessories. As always . . . in color or monochrome . . . it's Du Mont to be first with the finest!

HYFLUX for HI-FI

NOW AVAILABLE
No. 9 Speaker Magnets
with
6 MILLION $B_d H_d$ max
GUARANTEED!

Now... for the First Time

the RETMA Standard No. 9 Loudspeaker Magnet is available with a minimum energy product of over 6 million BH max. Made of Hyflux Alnico V HE*, it provides the highest energy product of any commercial Alnico.

The immediate advantages it offers to users of the RETMA No. 9 Magnet are:

- The highest sound level possible.
- A better transient response—resulting from the higher gap density which increases the damping factor—assures a full range of tones and overtones.
- The truest possible reproduction of sound.



High Energy—grain-oriented Alnico V.

The Indiana Steel Products Company is proud to introduce this improved No. 9 speaker magnet to the audio industry. Investigate its distinct advantages for your speaker. Price and delivery information upon request.

THE INDIANA STEEL PRODUCTS COMPANY
Valparaiso, Indiana

World's largest Manufacturer of Permanent Magnets

INDIANA PERMANENT MAGNETS

IN

Complete Telemeter

PACKAGE

BY

BENDIX - PACIFIC

These compact, rugged FM/FM telemetering packages are available for many types of applications. Numerous models of plug-in subcarrier oscillators and associated components are available as standard equipment to provide for maximum versatility and efficiency.

CUBICAL CONFIGURATION

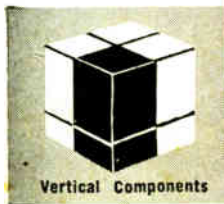

Vertical Components

RECTANGULAR CONFIGURATION



Horizontal Components

CYLINDRICAL CONFIGURATION



Wedge Shaped Components



Compact Four Band Telemeter, Models TATP-3 and TATP-4

These packages, each incorporating four plug-in subcarrier oscillators, when used with a power supply and RF transmitter, form a compact, rugged system for telemetering various functions. Each package contains its own voltage regulator and calibration relays. The packages may be combined to form an 8 or 12 band system. Each package measures approximately 4.5" in each dimension and weighs approximately 3 pounds including oscillators. Standard power supplies are available for operating up to 3 packages and a 2 watt RF transmitter. The model TATP-3 operates in any 4 of the RDB bands below 22 kc; the TATP-4 in any 4 of the bands from 22 kc up.

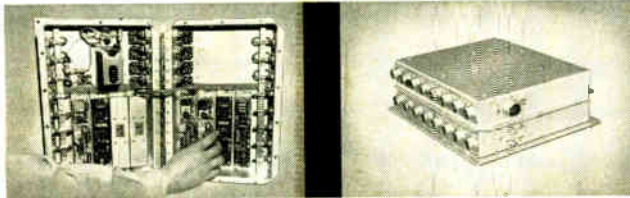

Universal Eight Band Telemeter, Model TATP-2

Operates on any eight RDB bands from 1.7 to 70 kc permitting any combination of 8 resistance, voltage or inductance type measurements to be made by merely plugging in the proper subcarrier oscillators. The unit has provisions for mounting a model TXV-13 crystal controlled transmitter. Connectors are provided for a minimum of eight remotely located pickups. Standard power supplies are available for operation from 6, 12, 28 VDC or 115 VAC 400 cps power sources. Dimensions - 14" x 12.4" x 4.75".

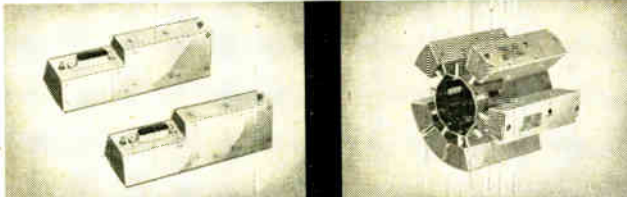

Cylindrical Telemeter Configuration, Model TJW-1

These packages are built up of individual 30° wedge shaped components which plug into a cylindrical mounting assembly, Model TJW-1. As many as 10 subcarrier oscillators or other components can be installed into a 6.5" circular opening, 5.5" long. A center opening, approximately 1.5" in diameter, can be utilized for cables and pressure lines. A two-watt crystal controlled RF transmitter is also available for mounting in this configuration.

Write for Complete Information

PACIFIC DIVISION • Bendix Aviation Corporation

11602 Sherman Way, North Hollywood, California

RADAR



SONAR



HYDRAULICS



TELEMETERING



ELECTRO-MECHANICAL



ULTRASONICS



How to measure the depth of D. Jones' locker

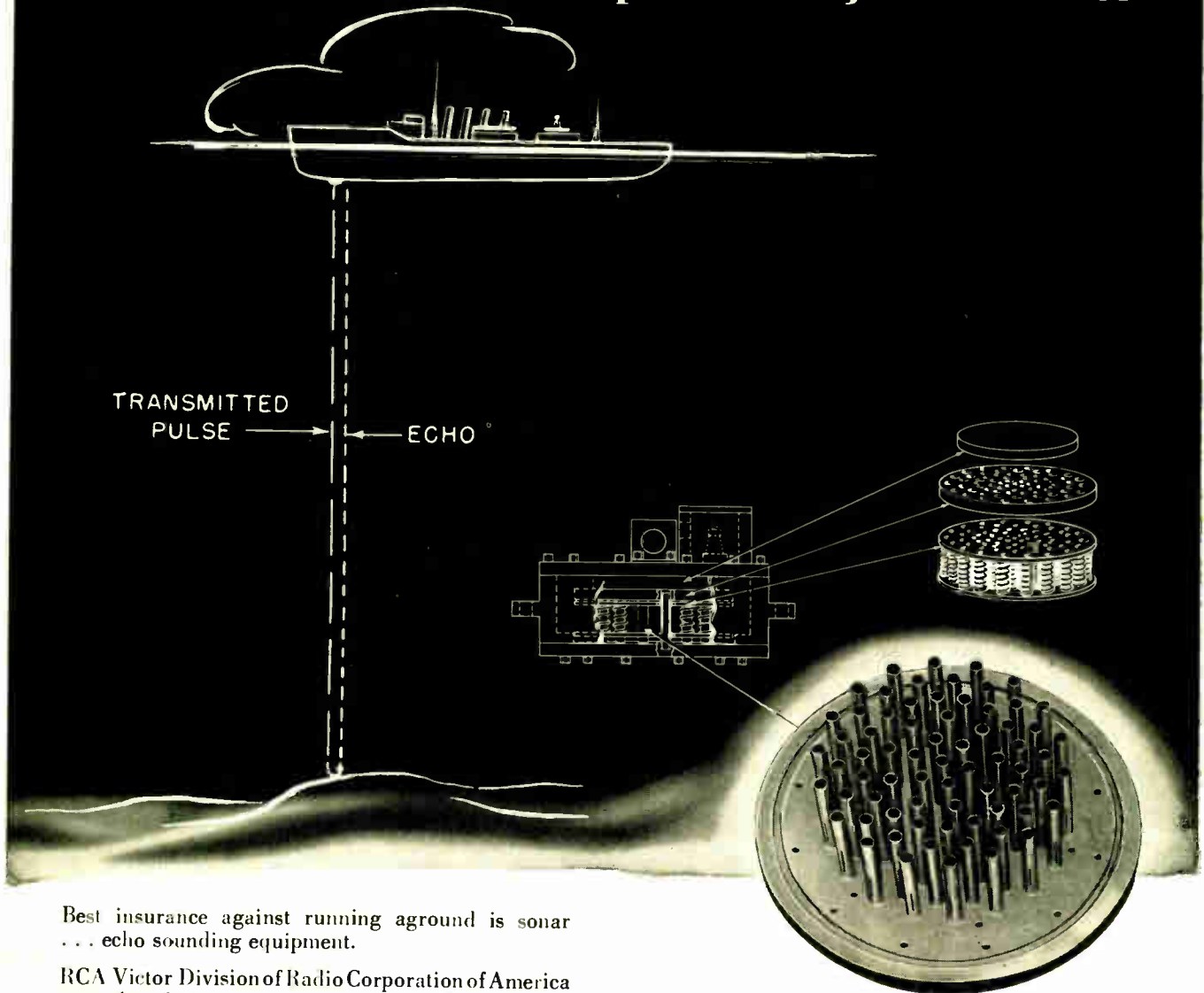

Best insurance against running aground is sonar . . . echo sounding equipment.

RCA Victor Division of Radio Corporation of America uses the phenomenon of magnetostriction to send and receive supersonic pulses and so determine the distance to a submerged object on the ocean's floor.

Magnetostriction—the familiar “Joule Effect” of your textbook days—is the ability of a ferromagnetic metal to change dimensions when magnetized. The metal of RCA echo sounding equipment is Superior Grade “A” nickel tubing.

70 pieces of Superior seamless nickel tubing, cold drawn to $\frac{3}{8}$ " O.D. x .020" wall thickness and cut to $\frac{1}{4}$ of the wave length of the alternating current signal, are soldered to a plate. Each length is enclosed by a coil.

Energizing the coil with alternating current, the tube expands and contracts, creating a piston effect on plate and diaphragm, sending out a supersonic wave. Likewise, reception of the echo wave by the diaphragm again causes the nickel tubes to pulsate and induce a current in the coil.

RCA Victor looks to Superior for accuracy and uniformity of analysis, precision drawing and cutting in large quantities. For cathodes, anodes, or tubing specialties, and tubing technology—ask Superior. Superior Tube Company, 2506 Germantown Avenue, Norristown, Pa.

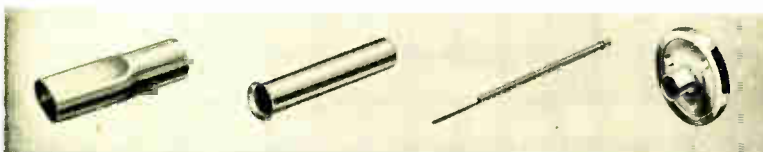

Seamless Nickel Anode. Flattened one end. .500" O.D. x .025" Wall x 1.625" long.

Seamless Nickel Cathode. Round, flanged one end, .070"/.072" I.D. x .0025" Wall. .295" long.

Lockseam* Nickel Cathode. Round, flanged, single bead, .045" O.D. x .0021" Wall. 27 mm long.

Disc Cathode .121" O.D. .312" long.

Superior
THE BIG NAME IN SMALL TUBING

All analyses .010" to $\frac{3}{4}$ " O.D.

Certain analyses in Light Walls up to $2\frac{1}{4}$ " O.D.

Many types of nickel cathodes—made in Lockseam* from nickel strip, disc cathodes, and a wide variety of anodes, grip cups and other tubular fabricated parts are available from Superior. For information and Free Bulletin, address Superior Tube Company, Electronics Division, 2500 Germantown Avenue, Norristown, Pa.

*Manufactured under U.S. Patents.

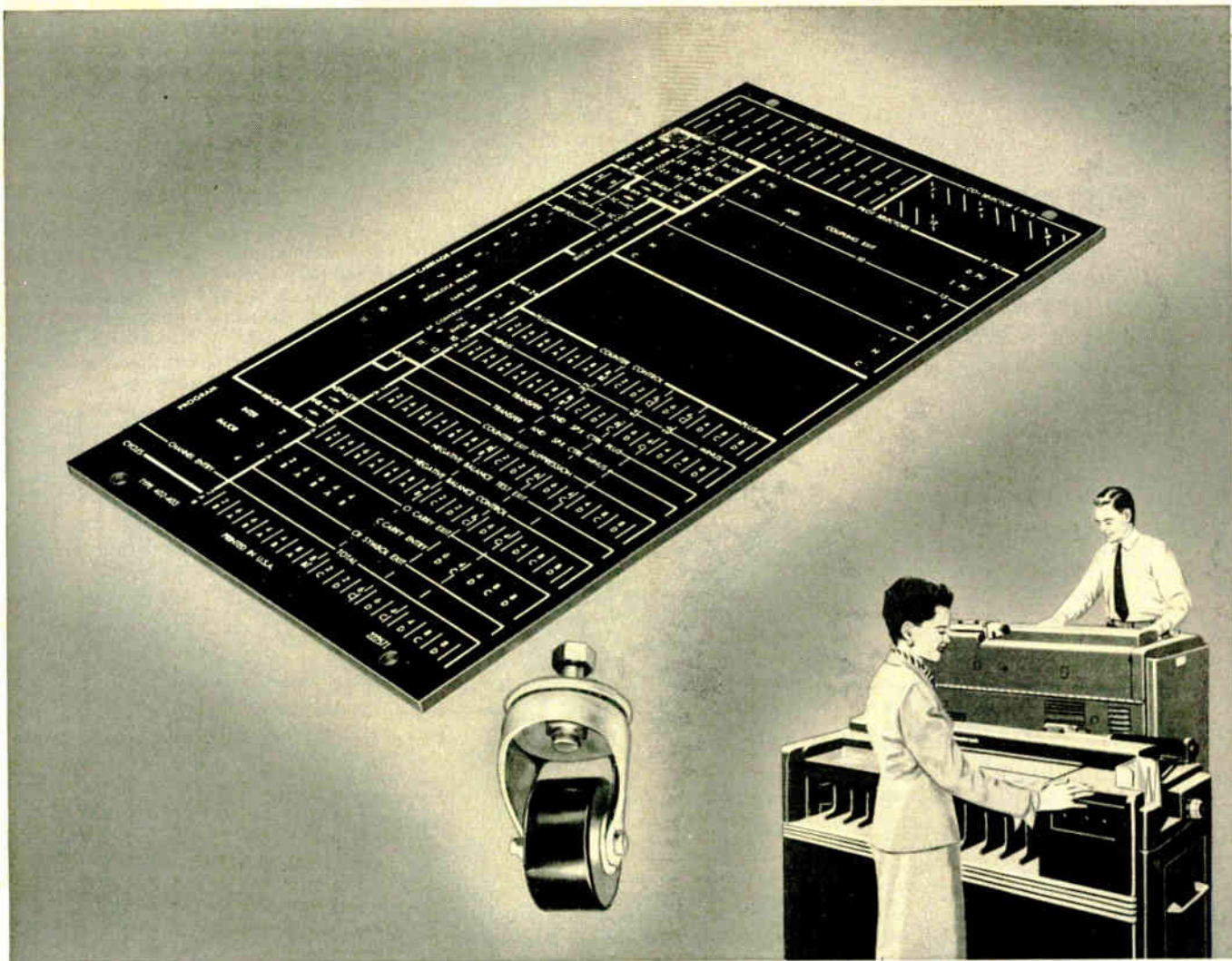

Head and feet for an office worker who neither errs nor tires

Properties of Synthane

In addition to those mentioned in the text, Synthane has the following important properties:



Chemical resistance. Synthane resists most acids and alkalis in moderate solutions, and corrosive atmospheres.



Temperature resistance. Synthane is thermosetting, will not flow under elevated temperatures. Grades resisting up to 400° F are available.



High impact strength. Synthane stands up well in applications where it is subject to vibration, pounding and shock loads.



Mechanical strength. Synthane exhibits excellent strength under tension, compression, and other loads. It will not delaminate.



Availability. Synthane is supplied in more than 33 grades of sheets, also in rods, tubes and molded-laminated or molded-macerated parts. A complete fabricating service is available.

• The uncanny ability of tabulating machines to do complicated jobs quickly and accurately is famous. One of the materials which helps to make this possible is *Synthane*—a laminated plastic.

Synthane serves as the base for the brains of the machines—the plug boards upon which the control circuits are set up. *Synthane* is excellent for the purpose because of its combination of high dielectric strength, resistance to moisture, dimensional stability and ease of machining. *Synthane* is printable, too—circuit designations are

readily printed on its surface.

On tabulating machines, casters that are friendly to office-type flooring are needed. Casters of molded-macerated *Synthane* fill the bill. *Synthane* caster wheels are strong, do not flatten by constant pressure, and do not mar office floors.

Should you require a versatile material—one with many properties in combination—*Synthane* may be your answer. Our catalog tells the full story. To receive yours, drop us a note on your letter-head. Synthane Corporation, 8 River Road, Oaks, Pa.

Our 25th Year
SYNTHANE CORPORATION, OAKS, PA.

SYNTHANE
LAMINATED **S** PLASTIC



computers . . .

for fire control,
bombing,
gun data,
navigation,
and shoran.

Since 1935

MAXSON
ENGINEERING
has developed
and produced
computers.

Our long experience
is at your
disposal.

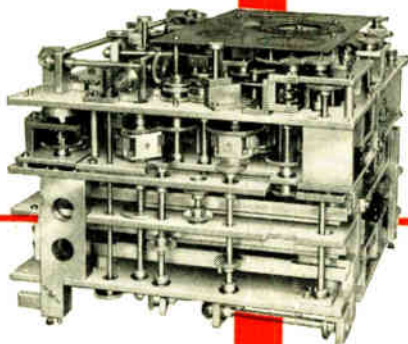

THE W. L. MAXSON CORPORATION

460 WEST 34TH STREET, NEW YORK 1, NEW YORK
Plants at Long Island City, N. Y. and Old Forge, Pennsylvania



SPEED UP factory and service tests!

UHF TV SWEEP GENERATOR MODEL 130

Features continuous frequency coverage in one band; at least one volt output into 75 ohms; wide sweep; blanked signal on return sweep provides a reference baseline.

SPECIFICATIONS

Freq. Range: 450-900 mc.
Sweep Width: 0-40 mc min.
Sweep: 60 cycle, sine wave.
Output: (1.) 0.1-1.0 volts
(2.) 0.01-0.1 volts approx.



FM SIGNAL GENERATOR MODEL 100C

Designed to give precision performance over a single tuning range (27-230 mc). Negligible leakage; low spurious outputs; no auxiliary frequency changer unit required.

Write for specifications and catalog on complete line of measuring equipment.

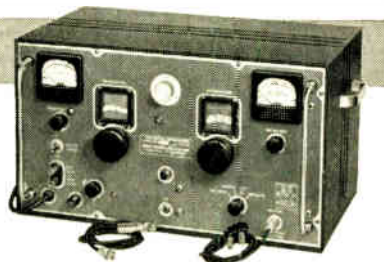

NEW LONDON INSTRUMENT

P. O. BOX 189 P
NEW LONDON, CONN.



News—New Products

These manufacturers have invited PROCEEDINGS readers to write for literature and further technical information. Please mention your I.R.E. affiliation.

(Continued from page 26A)

Vacuum Capacitors

A new range of high-energy content, vacuum capacitors has been announced by United Electronics Co., 42 Spring St., Newark 2, N. J., different type numbers each with the same over-all physical dimensions; nominal 5 1/4 inch length, 2 3/4 inch diameter. Each type is rated for 35,000 volts peak; 100 amperes EMS.



Exhaust tube seal-off tip is not exposed.

The capacitors are featured by wide circumference low-resistance contact provisions. Copper is used for all internal active area as well as for external terminals. Mounting and contact is accomplished by use of 2-inch diameter phosphor bronze rings supplied with the capacitors.

The 5 types differing as to capacitance values, 250, 200, 150, 100, and 50 μf , carry the following designations: CAP 250/100/35 EC, CAP 250/100/35 EC, CAP 150/100/35 EC, CAP 100/100/35 EC, CAP 50/100/35 EC.

Temperature coefficient in these new units is low, and the periphery contact area assures efficient connection to circuitry.

New Galvanometer

A new and highly sensitive galvanometer, designed for use with relatively high impedance transducers, has been developed by the Heiland Research Corp., 130 East Fifth Ave., Denver 9, Colo. This improved type is inter-changeable with all other types of Heil and galvanometers.

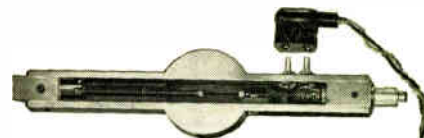

The new galvanometer, type 40-1000, designed and manufactured to stand up under the most exacting operational and environmental conditions, has a frequency of 40 cps, a sensitivity of 2.8 microamperes per inch (12 inch optical arm) and external damping resistance of 1,000 ohms, and a coil resistance of 109 ohms.

Other features include: Solid case construction completely dustproof, rotational limit stop, improved connector terminal, rapid horizontal and vertical adjustment.

(Continued on page 66A)

IT PAYS TO ASK THE **STACKPOLE** MAN!



These Stackpole sales engineering representatives can help you in many ways—from making cost-saving suggestions to providing engineering samples and helping you procure dependable, economical components to match your production requirements and scheduling. Write, wire or call the engineer in your territory next time you need any of the materials listed below.

Electronic Components Division
STACKPOLE CARBON COMPANY
St. Marys, Pa.

FIXED AND VARIABLE RESISTORS

SPECIAL RESISTORS

LINE, SLIDE OR ROTARY-ACTION SWITCHES

IRON CORES
 All types and shapes

MOLDED COIL FORMS
 With or without iron core sections

CERAMAG[®] ferromagnetic CORES

Low Value FIXED COMPOSITION CAPACITORS

STACKPOLE

BEVERLY HILLS, CAL.



S. L. Spraggins
 373 South Robertson
 PHONE: Crestview
 5-1544

PLAINVILLE, CONN.



Karl Dornish
 105 Farmington Ave.
 PHONE: Plainville 653

ATLANTA, GEORGIA



Floyd Fausett & Son
 2380 Sewell Rd., S.W.
 PHONE: Amherst 6235

CHICAGO 13, ILLINOIS



Allen Woods
 3403 Broadway
 PHONE: Buckingham
 1-4200

INDIANA



C. R. Booth
 Room 317
 4000 W. North Ave.
 Chicago 39, Ill.
 PHONE: Capital
 7-2810

DEARBORN, MICHIGAN



J. E. Vollmer
 24800 Winona Drive
 PHONE: Logan 1-6778

MINNEAPOLIS 4, MINN.

H. M. Richardson
 9 East 22nd Street
 PHONE: GENEva 4078



GLENSIDE (Phila.), PA.

25 South Easton Rd. PHONE: Turner 1325
 J. R. Bengé Donald G. Brown



KANSAS CITY 2, MO.

M. E. Beltis
 Room 11
 406 W. 34th Street
 PHONE: 0772-0773



BUFFALO 3, NEW YORK

R. W. Mitscher
 487 Ellicott Sq. Bldg.
 PHONE: Washington
 2517



NEW YORK 1, N. Y.

Joseph Sprung
 254 West-31st Street
 Room 1104
 PHONE: Longacre
 5-1820



CINCINNATI, OHIO

W. C. Laing
 3253 Lambert Place
 PHONE: East 1435



CLEVELAND, OHIO

C. A. Hammer
 Standards Bldg.
 PHONE: Cherry 1-7600



DALLAS 9, TEXAS

Edward F. Aymond
 4310 Maple Avenue
 PHONE: Logan 5233



OAKVILLE, ONT., CANADA

W. T. Barron
 Box 126
 PHONE: OAKville 2410





At least one of your interests is now served by one of IRE's 21 Professional Groups

Each group publishes its own specialized papers in its *Transactions*, some annually, and some bi-monthly. The larger groups have organized local chapters, and they also sponsor technical sessions at IRE Conventions.

Aeronautical and Navigational Electronics (G 11)	Fee \$2
Antennas and Propagation (G 3)	Fee \$4
Audio (G 1)	Fee \$2
Broadcast & Television Receivers (G 8)	Fee \$2
Broadcast Transmission Systems (G 2)	Fee \$2
Circuit Theory (G 4)	Fee \$2
Communication Systems (G 19)	Fee \$2
Component Parts (G 21)	Fee \$2
Electron Devices (G 15)	Fee \$2
Electronic Computers (G 16)	Fee \$2
Engineering Management (G 14)	Fee \$1
Industrial Electronics (G 13)	Fee \$2
Information Theory (G 12)	Fee \$2
Instrumentation (G 9)	Fee \$1
Medical Electronics (G 18)	Fee \$1
Microwave Theory and Techniques (G 17)	Fee \$2
Nuclear Science (G 5)	Fee \$2
Quality Control (G 7)	Fee \$2
Radio Telemetry & Remote Control (G 10)	Fee \$1
Ultrasonics Engineering (G 20)	Fee \$2
Vehicular Communications (G 6)	Fee \$2

IRE Professional Groups are only open to those who are already members of the IRE. Copies of Professional Group *Transactions* are available to non-members at three times the cost-price to group members.



The Institute of Radio Engineers
1 East 79th Street, New York 21, N.Y.

USE THIS COUPON

Miss Emily Sirjane
IRE—1 East 79th St.
New York 21, N.Y.

PG 5-54

Please enroll me for these IRE Professional Groups

..... \$.....
..... \$.....

Name
Address
Place

Please enclose remittance with this order.

Professional Group on Broadcast and Television Receivers

The field of broadcast receivers is one which is closely associated with the general public, perhaps more so than any other branch of the radio engineering field. In fact, to the layman the term "radio" is synonymous with "broadcast receiver."

As a result, the receiver engineer has been concerned with an additional factor not generally common to other fields, namely, that of responding to—or endeavoring to create—public demand for a product. This factor has played a prominent role in such developments as FM, car radios, portable receivers, and black-and-white television sets. It is now conspicuously evident in connection with current efforts to produce and market color television receivers.

The IRE Professional Group on Broadcast and Television Receivers is playing a major role in making available vitally needed technical information, not only on color television, but on all aspects of the receiver field. Through this exchange of information, the radio and television industry is gaining important data which will be helpful in solving the engineering problems it faces and in successfully meeting the "public demand" factor mentioned above.

The Group has been particularly active in sponsoring technical sessions at most of the national meetings held throughout the country during the year: the Radio Fall Meeting, the Spring Television Conference in Cincinnati, and the IRE National Convention, to mention but a few.

The Group also publishes its own technical publication, called *Transactions*, which is distributed to some 1200 members as a part of their \$2.00 assessment fee. The *Transactions*, which is published on a quarterly basis, has become a chief source of information on the latest technical developments in the field of broadcast and television receivers.

W. R. G. Baker

Chairman, Professional Groups Committee

Working on complex Radar or UHF Systems

**HERE'S EXPERT HELP
YOURS FOR THE ASKING!**

We've honestly earned our reputation as experts in electronic development, design and production . . . and our complete facilities are always at your service.

Our two plants have a production area of more than 122,000 square feet. They are laid out for peak efficiency in development, design, fabrication and assembly of every component in electronic projects from simple test equipment to complex radar systems.

Here are complete departments for metal working . . . welding . . . riveting . . . heat treating . . . plating . . . engraving . . . assembling . . . finishing . . . packaging and shipping. Approximately 500 trained employees and experienced electronic engineers assure accurate and efficient results.

Take advantage of our unique and complete ability to serve you, regardless of the size and scope of your electronic projects. Your inquiry will be expertly and promptly evaluated and our suggestions will be of interest and value to you. There is, of course, no obligation.



Lavoie Laboratories, Inc.

MORGANVILLE, NEW JERSEY

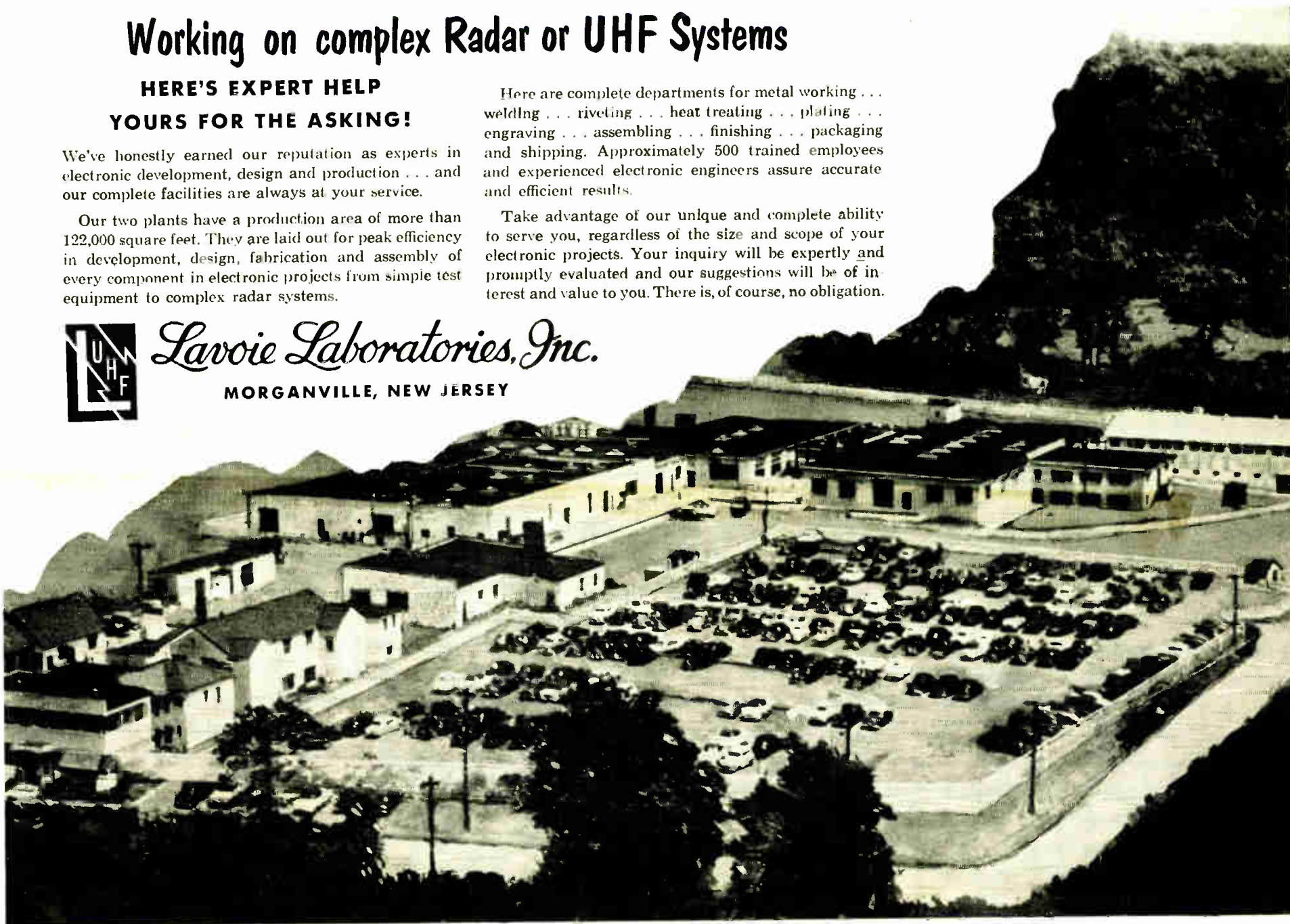

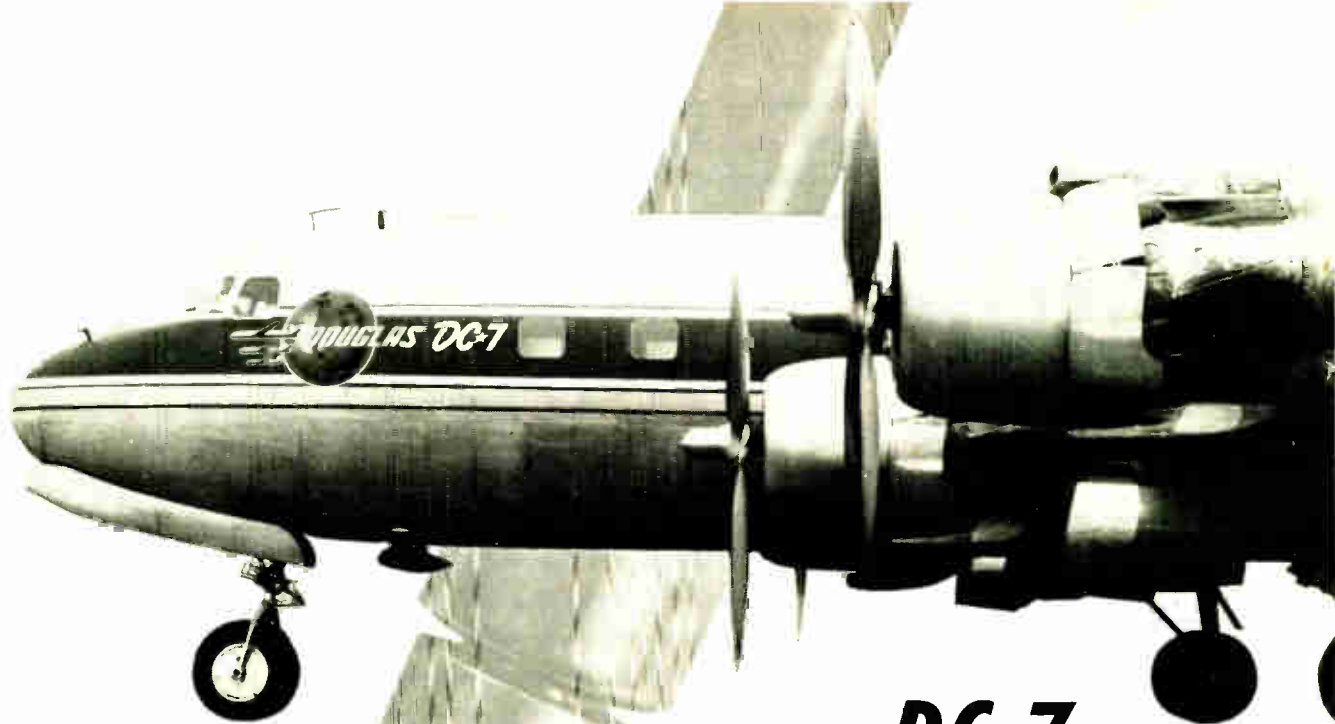

THE NEW DOUGLAS *DC-7*

Diamond Connectors at work in
DC-7 radio equipment, helping
to insure reliable communication.

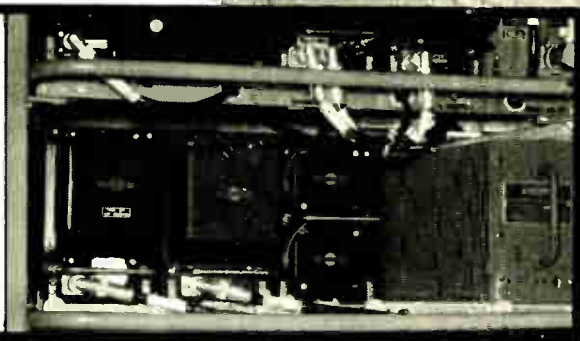

Depends on

DIAMOND CO-AXIAL CABLE CONNECTORS

As dependability in electronic circuits becomes more critical, coordinated engineering and manufacturing effort of a highly refined degree becomes an unqualified "must".

This Company is proud that its product has been selected for use in THE NEW DOUGLAS DC-7.



DIAMOND MANUFACTURING CORPORATION
7 North Avenue, Wakefield, Massachusetts

Another RMC First

VACUUM CAST

High Voltage DISCAPS

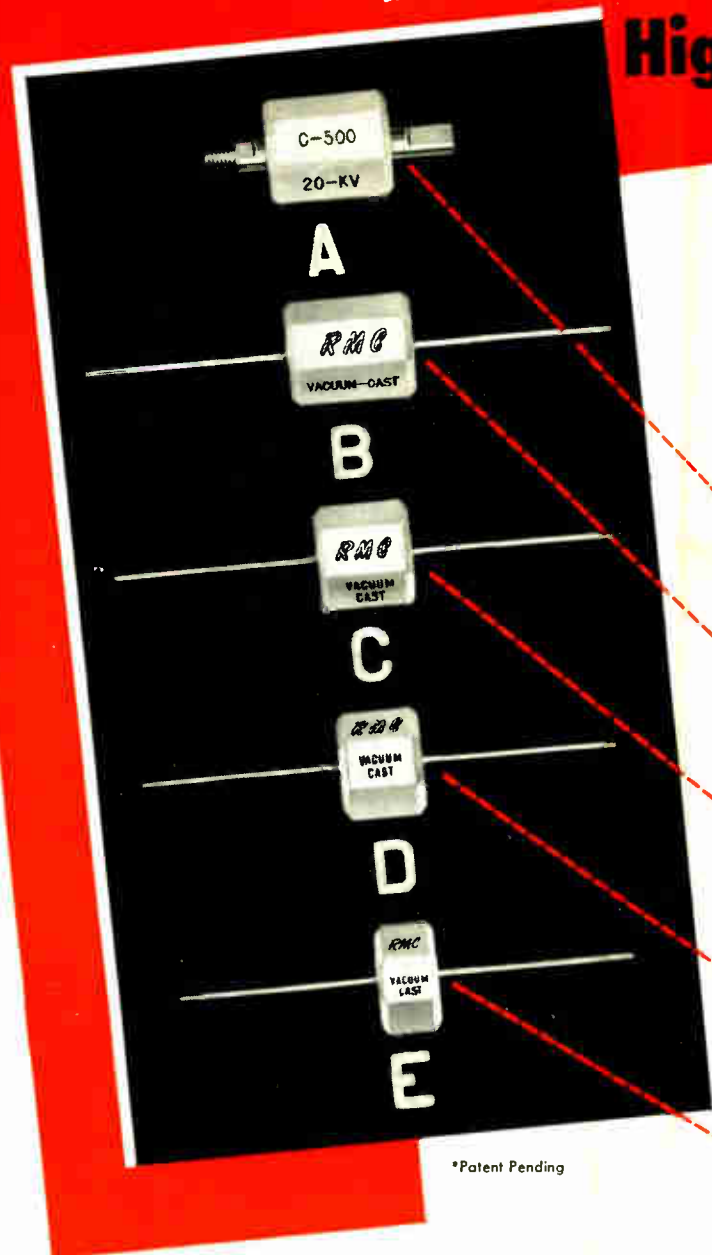

*Patent Pending

Vacuum Cast DISCAPS answer the demand for a dependable ceramic capacitor for high voltage applications.

The RMC Vacuum Cast process removes all air and gases to form a hermetically sealed casing in perfect contact with dielectric and terminals. The possibility of cracks or fissures in the casing is eliminated.

The exclusive casting material meets all the requirements of an outstanding capacitor casing; it is highly impervious to moisture, has great mechanical strength and exceptionally good electrical characteristics.

For extra dependability specify RMC Vacuum Cast DISCAPS... they are priced competitively with ordinary molded types. Your inquiry is invited.

1" x 7/8" across flats.
20 KV-500 mmfd with standard and special terminals.

Size-1" x 7/8" across flats.
20 KV-500 mmfd with No. 16 wire leads. Lead lengths optional.

3/4" x 7/8" across flats.
15 KV-1200 K-50 to 200 mmfd
15 KV-4500 K-200 to 1000 mmfd

5/8" x 7/8" across flats.
10 KV-1200 K-50 to 250 mmfd
10 KV-4500 K-250 to 1000 mmfd

7/16" x 7/8" across flats.
8 KV-N-1500-10 to 50 mmfd
8 KV-1200 K-50 to 250 mmfd
8 KV-4500 K-250 to 1000 mmfd

C-D-E have No. 16 or No. 18 wire leads-length optional.

POWER FACTOR AT 1000 CPS: 1% MAX.
LEAKAGE RESISTANCE: Guaranteed greater than 50,000 Megohms
LEAKAGE RESISTANCE AFTER HUMIDITY: 5000 Megohms

A New Development from the
RMC Technical Ceramic Laboratories

DISCAP
CERAMIC
CAPACITORS



RADIO MATERIALS CORPORATION

GENERAL OFFICE: 3325 N. California Ave., Chicago 18, Ill.

FACTORIES AT CHICAGO, ILL. AND ATTICA, IND.

DISTRIBUTORS: Contact Jobbers Sales Co., 146 Broadway, Paterson 1, N. J.

RAYTHEON MAGNETRONS AND KLYSTRONS MEET EVERY FREQUENCY AND POWER NEED

Two of these tubes just declassified

RK6230/QK299B — tunable pulse magnetron (8900-9400 Mc), 1 Kw average peak power



RK6410/QK338 — fixed frequency, pulse magnetron (2750-2860 Mc), 5 megawatt average peak power

RK2J51 — tunable pulse magnetron (8500-9600 Mc), 50 Kw average peak power

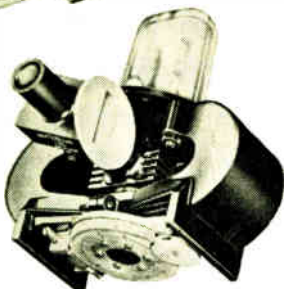

RK5976—mechanically tunable klystron (6250-7425 Mc), average power 100 milliwatts

RK6116 — thermally tuned ruggedized klystron (8500-9660 Mc), average power 25 milliwatts



RK5721—klystron tunable with external cavities from 3600 to 10,500 Mc. Average power 125 milliwatts in the 2 $\frac{3}{4}$ reflector mode (4290-8340 Mc)

Raytheon also manufactures transmitting tubes, storage tubes and square law tubes

VELOCITY VARIATION REFLEX OSCILLATORS

Characteristics of Unclassified
Tube Types

Complete data on tube type available upon request



Raytheon Manufacturing Company
Power Tube Division
WALTHAM 54, MASSACHUSETTS

MAGNETRON OSCILLATORS

Characteristics of Unclassified
Tube Types

Complete data on tube type available upon request



Raytheon Manufacturing Company
Power Tube Division
Waltham 54, Massachusetts

Now Available —

CONSOLIDATED DATA BOOKLETS FOR RAYTHEON MAGNETRONS & KLYSTRONS

WRITE FOR YOUR COPIES TODAY

These valuable data booklets, which we will be glad to send you, list most principal unclassified types now manufactured — give maximum ratings, typical operating values, frequency ranges. Indispensable to every microwave engineer's file.

Raytheon is the world's largest producer of CW and pulse magnetrons, many tunable mechanically or electrically. A compact, efficient source of

power, magnetrons are being used in an ever increasing number of applications.

Raytheon klystrons, which can be tuned mechanically or thermally, fit the widest range of requirements with tubes available from 550 to 60,000 Mc.

Please feel free to call on us for Application Engineering Service on your microwave problems. There is no cost or obligation.

WRITE TODAY for your data booklets. Please address Raytheon Manufacturing Co., Power Tube Sales — Section PL-03, Waltham 54, Mass., or telephone Waltham 5-5860, Ext. 2443.



Raytheon Manufacturing Company, Power Tube Division, Waltham 54, Mass.

How **COLLINS INDUSTRIAL COMPONENTS** can help you

During the past 20 years Collins Radio Company has pioneered many of the outstanding advancements in the radio-communications and electronics industry. Collins engineers had to develop unique and unusual systems and components to meet the superior standards of Collins equipment. These components, plus application recommendations, are now available to the electronics industry. Collins industrial components can help you. Send the coupon below for complete information.



MECHANICAL FILTERS

Compact, permanently tuned band pass filters for intermediate frequency amplifier applications. Mechanical elements of the filter provide characteristics close to the ideal rectangular selectivity curve. It is a hermetically sealed component requiring no adjustments. Selectivity curves for two of the 23 standard Mechanical Filters are reproduced here.

(Fig. 1) Type F455B-31 — Center frequency, 455 kc; band-width, 3.1 kc; plug-in terminal arrangement.

(Fig. 2) Type F250Z-2 — Center frequency, 248.2 kc; band-width, 3.2 kc; solder terminal arrangement.

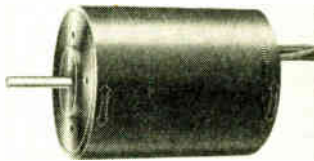
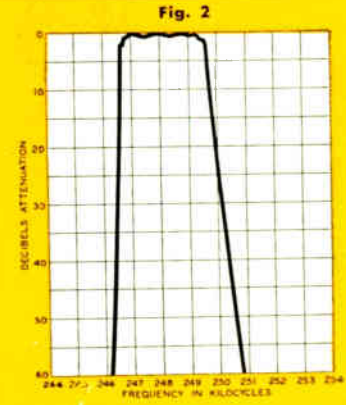
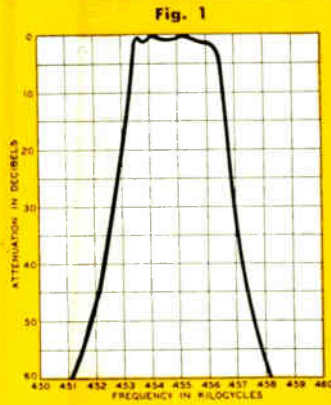

Collins HYSTERESIS MOTORS

Useful for driving timing devices, facsimile equipment, commutators, or any device which must rotate at an absolutely constant speed regardless of load or line voltage variations. Type 370A-1 Wide Band Synchronous Motor is illustrated . . . produces synchronous rotation from motionless to 30,000 RPM.

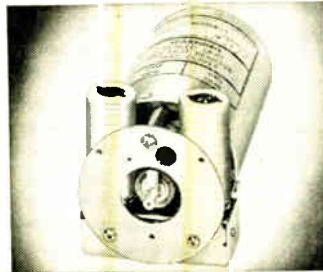

Collins OSCILLATORS

Long famous for their accuracy and stability, Collins Variable Frequency Oscillators are now available. They give transmitters, receivers, frequency standards or test equipment accurate linear dial calibration and superb stability. Collins Oscillators are available in a number of frequency ranges.

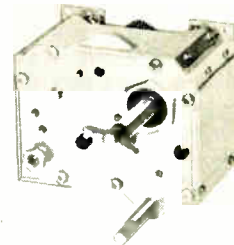

Collins AUTOTUNES AND AUTOPOSITIONERS

Collins Autotunes, the basis for both remotely and directly controlling automatic tuning of high quality communication equipment, are suitable for many industrial applications. Collins Auto-positioners are used where up to 20, or more, pre-determined, fixed positions are needed. Available as individual units or in complete systems.



COLLINS RADIO COMPANY

Cedar Rapids, Iowa

11 W. 42nd Street, NEW YORK 36
 1930 Hi-Line Drive, DALLAS 2
 2700 W. Olive Avenue, BURBANK
 COLLINS RADIO COMPANY OF CANADA, LTD.
 74 Sparks St., OTTAWA, ONTARIO

Please send me complete information on:

Mechanical Filters Autotunes Oscillators
 Hysteresis Motors

NAME _____
 ADDRESS _____
 COMPANY _____
 CITY _____ STATE _____

The *IMPROVED* Model 310A BALLANTINE Sensitive Electronic Voltmeter



MODEL 310A
Price \$235

To measure.....40 microvolts to 100 volts
from.....10 cycles to 2 megacycles
with accuracy ($>100 \mu v$)...3% to 1 mc; 5% above
Input impedance.....2 megohms shunted by 15 mmfd
below 10 mv; and by 8 mmfd above

Usable as null detector sensitive to $10 \mu v$ from 5 cps to 4 mc

Improvements include lower noise level; enhanced frequency response; reduced susceptibility to line voltage variations; incorporation of premium tubes throughout amplifier system, etc.

Featuring Customary BALLANTINE

SENSITIVITY — ACCURACY — STABILITY

Write for catalog for more information about this and other BALLANTINE voltmeters, calibrators, amplifiers and accessories.

BALLANTINE LABORATORIES, INC.



102 Fanny Road, Boonton, New Jersey

**35,000 Member Engineers
find IRE DIRECTORY is
5 Ways Faster!**

1. It shows all the radio-electronic products a firm makes, by code numbers after its alphabetical listing.
2. It groups products into ten directories of related engineering interest. It does not mix meters with motors, or components with test instruments because of names that are alike.
3. It indexes all products into 100 basic classes, cutting duplication and gaining speed by brevity.
4. Yet, it provides plenty of detailed product identification through over 500 sub-classes by a concise number system which avoids confusing repetition.
5. The Machol Thumb Index System (picture below) gives dictionary-like convenience in speedy finding of 100 product groups.

A few minutes study of the IRE DIRECTORY method will repay you well in saved time and easy use. Get the most out of your IRE DIRECTORY.

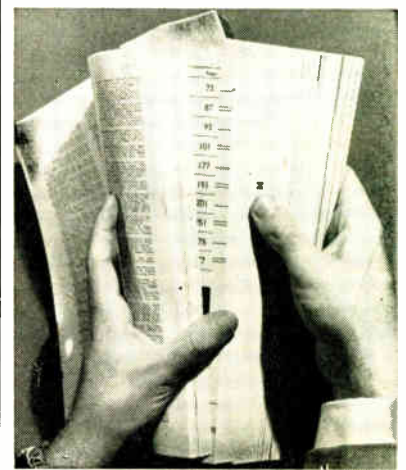

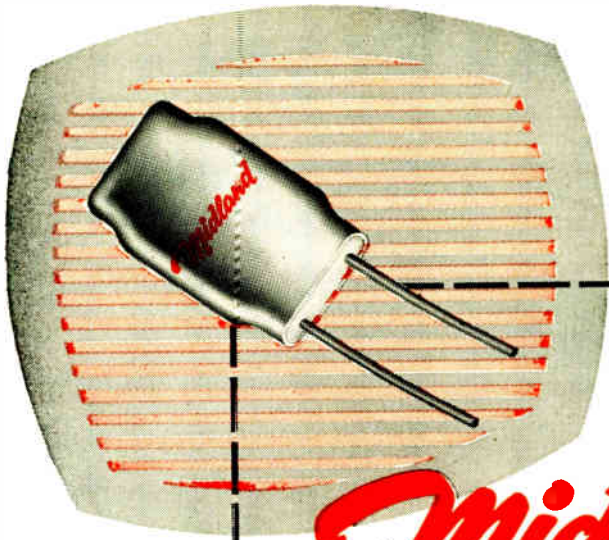

picture of Perfection

Midland

FREQUENCY CONTROL CRYSTALS

for **CO** **LO** **R** television

Color television brings a new set of critical demands for precision frequency control. Accuracy, stability and uniformity of crystals used in this application must be as nearly perfect as materials, methods, and quality controls can make them.

Midland meets this demand not only with a crystal of complete reliability in this new field, but also with a solid background of pioneering in the development of frequency control crystals and circuits for this and many other exacting applications.

Midland is prepared NOW to supply you in quantity with Color TV Crystals to meet your exact specifications, and to counsel on all matters concerned with this subject.

*Whatever your Crystal need, conventional or specialized
When it has to be exactly right, contact*



Midland

MANUFACTURING COMPANY, INC.
3155 Fiberglas Road, Kansas City, Kansas

WORLD'S LARGEST PRODUCER OF QUARTZ CRYSTALS

Speer makes it easy for you to choose the right Carbon resistor!

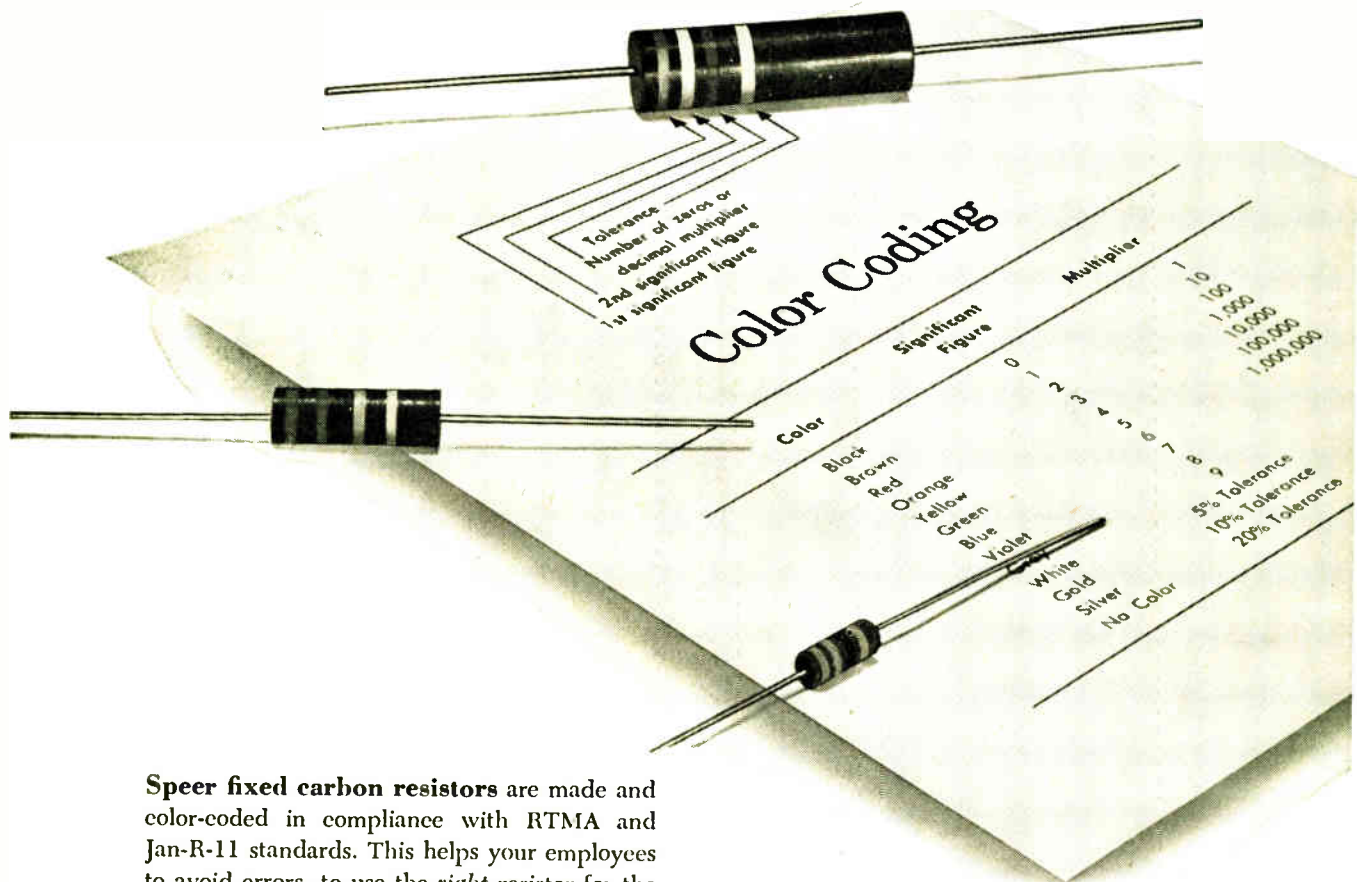

Speer fixed carbon resistors are made and color-coded in compliance with RTMA and Jan-R-11 standards. This helps your employees to avoid errors—to use the *right* resistor for the circuit every time.

Speer resistors are made better — are the right resistors for *every* circuit. By using very high pressure to create an inseparable bond between the protective phenolic shell and the carbon core, Speer gives its resistors these important advantages:

1. More efficient heat transfer.
2. Greater ability to sustain overloads for long periods of time.
3. Uniform diameter resistive element for the entire length of the resistor, which eliminates weak points and potential burn-outs.

4. Uniformly thick protective covering over the entire length, which eliminates low-voltage breakdown between resistive element and adjacent conductor — makes for minimum change in resistance when subjected to adverse humidity conditions.

All shipments of Speer resistors are given numerous tests for resistance rating, and are backed by a minimum resistance change when exposed to an accelerated ten-day humidity test. Speer manufactures a complete line of ½, 1 and 2 watt resistors in all standard values from 10 ohms to 20 megohms. Nonstandard values are available for special applications.

Write today for
your free copy of Speer
Resistor's new
complete catalog



SPEER RESISTOR DIVISION SPEER CARBON COMPANY

Bradford, Pennsylvania

Other Divisions: Jeffers Electronics
International Graphite & Electrode

CHATHAM advance-designed yesterday

— in
industry-wide
use today!

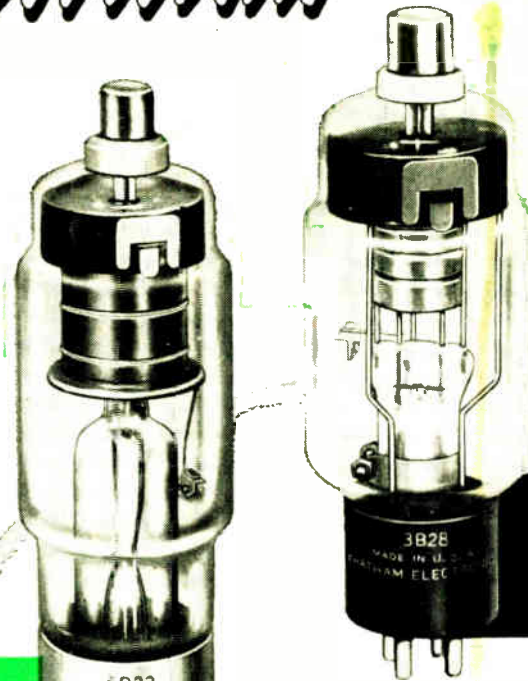

AMPLIFIERS • REGULATORS • INERT GAS
AND MERCURY RECTIFIERS • MERCURY,
INERT GAS AND HYDROGEN THYRATONS

CHATHAM SPECIAL-PURPOSE TUBES



● **3B28 RECTIFIER**

Rugged half-wave Xenon filled rectifier. Operates in any position. Ambient temperature range -75° to $+90^{\circ}$ C. Inverse peak anode voltage 10,000, average anode current .25 amps. Filament 2.5v., 5 amp.

● **4B32 RECTIFIER**

Ruggedly built, half-wave Xenon filled rectifier. Ambient temperature range -75° to $+90^{\circ}$ C. Inverse peak anode voltage 10,000, average anode current 1.25 amp. Filament 5v., 7.5 amp.

● **VC-1258 MINIATURE HYDROGEN THYRATRON**

for pulse generation. Handles 10 kw peak pulse power.

● **6336 TWIN TRIODE**

for voltage regulation. Features high plate dissipation, hard glass envelope.

● **6394 TWIN TRIODE**

Similar to 6336 except 26.5 volt heater instead of 6.3 volt heater.

● **5594 XENON THYRATRON**

Operates over wide ambient temperature range -55° C to $+90^{\circ}$ C.



5594



VC-1258



6394

STANDARD TYPES DIRECT FROM STOCK
PLUS SPECIAL DESIGNS BUILT TO REQUIREMENTS

Chatham specializes in the development of general and special purpose tubes for both electronic and industrial applications. Many of the tubes originally developed by Chatham to fill a specialized need, now number among the most widely used tubes in the industry. For complete information on Chatham tubes—either stock items or types built to your requirements—call or write today.



CHATHAM ELECTRONICS CORP.

Executive and General Offices: LIVINGSTON, NEW JERSEY
Plants and Laboratories: NEWARK and LIVINGSTON, NEW JERSEY

TRUSCON STEEL TOWERS

FOR AM • FM • TV
MICROWAVE

**year 'round reliability
for 'round-the-clock programing**

When your towers are by Truscon, there's less chance of your log reading "off the air" during storm seasons. Truscon-designed and engineered radio towers stand strong and tall under all kinds of weather conditions—and in all kinds of topography.

Truscon builds 'em for you tall or small . . . guyed or self-supporting . . . for AM, FM, TV, or Microwave transmission. Your phone call or letter to any Truscon district office—or to tower headquarters in Youngstown—will get your tower program going as soon as defense requirements allow.



TRUSCON®
a name you can build on

**TRUSCON STEEL DIVISION
REPUBLIC STEEL**

1072 ALBERT STREET • YOUNGSTOWN 1, OHIO
Export Dept.: Chrysler Bldg., New York 17, N.Y.

trifles make **PERFECTION...**
but **PERFECTION** *is no trifle*

#1 IN A
 SERIES OF
 TREMENDOUS
 TRIFLES

*3 1/2 ounces
 of
 perfection*

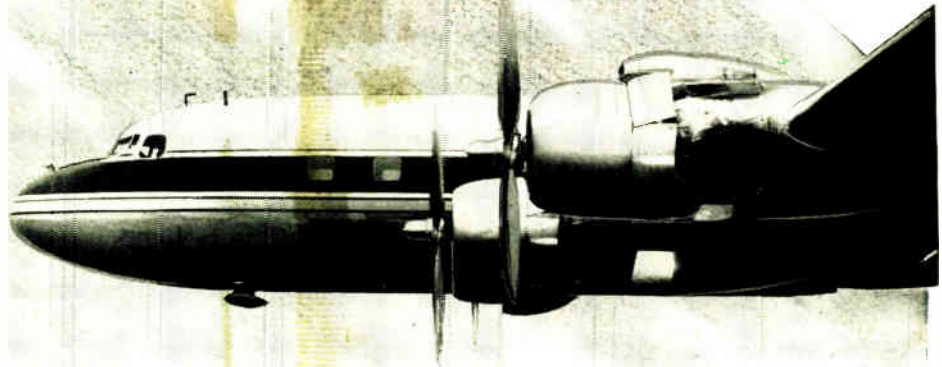

is **VITAL to 61 TONS of MAGNIFICENT
 PERFORMANCE**

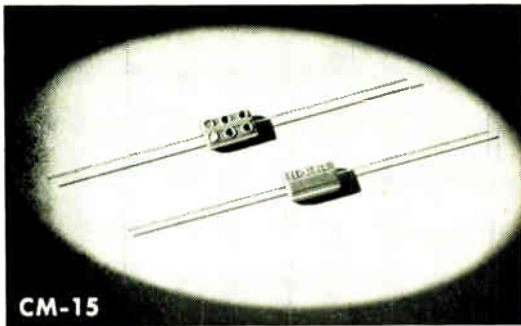

CM-15
 Smallest Molded Mica Capacitors 9/32" x 1/2" x 3/16"

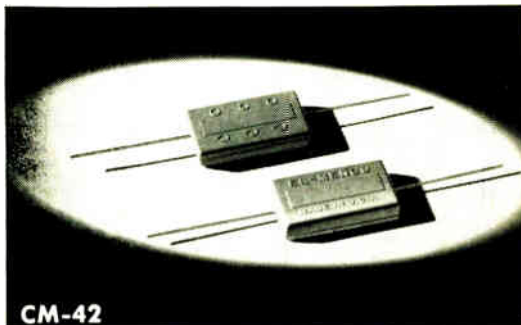

CM-42
 Made to Meet All MIL-C-5 Requirements. Largest Molded Mica Capacitors of Wire Terminal Type. 13/16" x 1-1/2" x 5/16"

Jobbers and Distributors are requested to write for information to Arco Electronics, Inc., 103 Lofayette St., New York, N. Y. — large stocks on hand — spot shipments for immediate delivery. Sole Agent for Jobbers and Distributors in U. S. and Canada.

When the mighty giants of the air lift their massive wings to fly, a thousand and more "tremendous trifles" instantly go to work in harmonious unison to give life and power. It is the perfection of these "trifles" that makes possible the magnificent performance of today's luxurious air liners.

The EL Menco Capacitor—CM-15—is one of these "tremendous trifles" that plays such a vital part in the efficient operation of aircraft communication.

EL Menco IS THE ONE OUT OF MANY CHOSEN FIRST
 Superiority of manufacture and dependability of performance make EL Menco first choice on the specification sheet . . . because EL Menco Capacitors are factory-tested at *double their working voltage* — they are *guaranteed stable* under the most adverse conditions. Whether you use our *high capacity* CM-42 (10-25,000 mmf) or our midget *low capacity* CM-15 (2-525 mmf) you have guaranteed assurance of job-tested, job-rated capacitors — tremendous trifles of perfection so vital to the magnificent performance of YOUR product.

ELECTRO MOTIVE is now supplying special silvered mica films for the electronic and communication industries — just send us your specifications.

WRITE FOR FREE
 SAMPLES AND
 CATALOG ON
 YOUR FIRM'S
 LETTERHEAD

EL-Menco
CAPACITORS



MOLDED MICA

MICA TRIMMER

Foreign Electronic Manufacturers Get Information Direct from our Export Dept. at Willimantic, Conn.

THE ELECTRO MOTIVE MFG. CO., INC.

WILLIMANTIC, CONNECTICUT

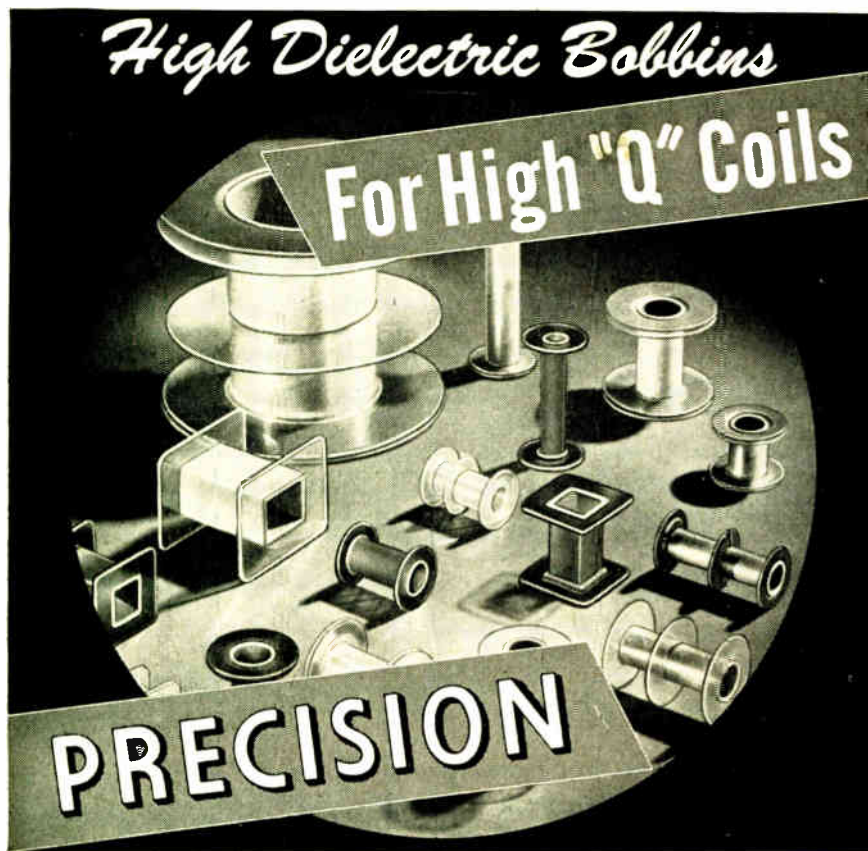

**MADE TO YOUR EXACT SPECIFICATIONS
IN ANY SIZE • SHAPE • QUANTITY**

Precision coil bobbins are fabricated from high dielectric materials and quality controlled to the most minute tolerances . . . Yet, because they are made on special high production equipment, they're available to you for prompt delivery at low unit cost.

Cores are spirally wound dielectric kraft, fish paper, acetate, phenol impregnated or combinations. Flanges are cut to any specification for all types of mountings.

Request illustrated bulletin. Send specifications for samples.

High Strength Low Cost Paper Tubes

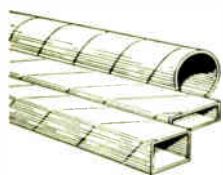

Accurately fabricated in any size, shape, ID or OD. Spirally wound from select dielectric materials. Crush resistant, with excellent dimensional stability. Subject to rigid control and inspection for tolerance and uniformity.

Ask for samples and Arbor List of over 2000 sizes.

Sales Representatives in:

New England:
Framingham, Massachusetts, Framingham 7091

Metropolitan New York, New Jersey:
Jersey City, New Jersey, Journal Square 4-3574

Upstate New York:
Syracuse, New York, Syracuse 76-8056

Northern Ohio, Western Pennsylvania:
Cleveland, Ohio, Atlantic 1-1060

Indiana, Southern Ohio:
Logansport, Indiana, Logansport 2555

Missouri, Southern Illinois, Iowa:
St. Louis, Missouri, Sterling 2318

Maryland:
Baltimore, Maryland, Plaza 2-3211

Philadelphia, Camden:
Philadelphia, Pa., Chestnut Hill 8-0282

California:
Pasadena, California, Sycamore 8-3919

Canada:
Montreal, Quebec, Canada, Walnut 2715



PRECISION PAPER TUBE CO.

2051 W. CHARLESTON ST. CHICAGO 47, ILL.

Plant No. 2: 79 Chapel St., Hartford, Conn.

News—New Products

These manufacturers have invited PROCEEDINGS readers to write for literature and further technical information. Please mention your I.R.E. affiliation.

(Continued from page 52A)

Sub-Miniature Resistor

A new resistor, Type A3606CG, has been developed by the I-T-E Circuit Breaker Co., Resistor Div., 1924 Hamilton St., Philadelphia 30, Pa., to meet the needs of sub-miniaturizing programs being carried out with many electronic and electronic-actuated devices throughout industry. Hermetically sealed, this resistor measures 3/16 inch in diameter by 1 1/2 inches long.

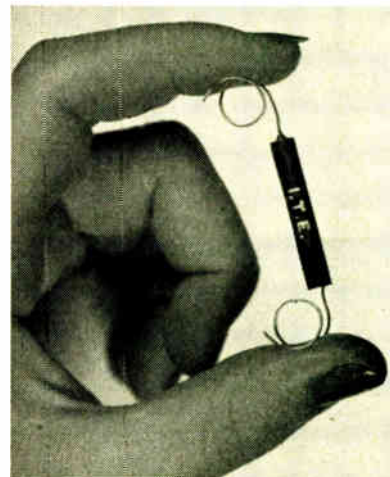

Resistors are built to customers' specifications, rated at 0.10 w. Maximum resistance, using Evenohm wire or its equivalent, is 500,000 ohms. Tolerances down to 0.1 per cent are standard. Axial lead wires are of 22-gauge tinned copper, 1 1/2 inches long.

Synchronous Motor For Rate-of-Turn Table

A new 115-volt, 60-cps, single phase 180 rpm synchronous motor for the Genisco Model C, Rate-of-Turn Table, a precision component used for calibrating and evaluating rate gyros, and for calibrating accelerometers up to ten G's, has been developed by Genisco, Inc., 2233 Federal Ave., Los Angeles 64, Calif.

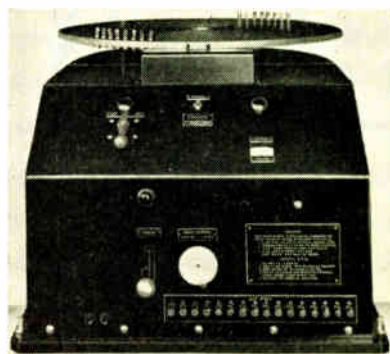

The new motor, designed specifically for this low-speed application, eliminates the usual belt-and-pulley or gear reduction systems. The motor switch may be

(Continued on page 68A)



Fast Delivery
ALSiMAG®

DIE PRESSED *Ceramics*

FAST DELIVERY . . . Our own die shop and four modern plants speed deliveries.

LARGE OR SMALL QUANTITIES . . . We have the most complete press facilities in the industry.

ECONOMICAL PRODUCTION . . . The right press for every job permits utmost economy.

ON SPECIFICATION . . . Backed by a reputation for accurate compliance with specifications for more than half a century.

WIDEST CHOICE OF MATERIALS . . . ALSiMag property chart gives more compositions and more physical data than any other source.

ENGINEERING COOPERATION . . . Send sketch and details of requirements for practical, cost-saving, delivery-expediting suggestions.

53RD YEAR OF CERAMIC LEADERSHIP
AMERICAN LAVA CORPORATION

A SUBSIDIARY OF MINNESOTA MINING AND MANUFACTURING COMPANY

CHATTANOOGA 5, TENNESSEE

OFFICES: METROPOLITAN AREA: 671 Broad St., Newark, N. J., Mitchell 2-8159 • SYRACUSE, N. Y.: 204 Harding Place, Phone 9-0656 • CLEVELAND: 5012 Euclid Ave., Room 2007, Express 1-6685 • NEW ENGLAND: 1374 Mass. Ave., Cambridge Mass., Kirkland 7-4498 • PHILADELPHIA: 1649 N. Broad St., Stevenson 4-2823 • ST. LOUIS: 1123 Washington Ave., Garfield 4959 • CHICAGO: 228 N. LaSalle St., Central 6-1721 • SOUTHWEST: John A. Green Co., 6815 Oriole Dr., Dallas 9, Dixon 9918 • LOS ANGELES: 5603 No. Huntington Dr., Capital 1-9114.

SEE OUR DISPLAY

BOOTH NO. 340

BASIC MATERIALS
 EXPOSITION

The Product
 Development Show

CHICAGO • MAY 17-20, 1954



Preformed Contact Finger Stock is an ideal electrical weather stripping around doors of equipment cabinets as well as being excellent for use with VHF and UHF circuitry. Silver plated, it comes in three widths— $\frac{3}{16}$, $\frac{3}{8}$ and $1\frac{7}{8}$ inches.

Variable vacuum capacitors come in three models, are lightweight, compact, eliminate the effects of dust and atmospheric conditions and have low inductance. Also available are eight types of fixed vacuum capacitors.

Air-system sockets, designed for Eimac tube types 4-400A, 4-1000A, 4X150A, and 4X150D, simplify cooling and assure adequate air-flow to various seals. The 4-400A socket can also be used with the 4-125A and 4-250A

radial-beam power tetrodes if desired.

HR heat dissipating connectors provide efficient heat transfer from the tube element and glass seal to the air while making electrical connections to plate and grid terminals. Precision machined from dural rod, HR connectors come in ten sizes to fit most of Eimac's internal anode tubes.

High Vacuum Rectifiers come in eight models, are instant heating, have radiation-cooled pyrovac* plates and can be operated in a variety of rectifying and voltage multiplying circuits. Also available are four types of mercury-vapor rectifiers.

* An Eimac trade name.



• For further information write our Application Engineering department

EITEL-McCULLOUGH, INC.

SAN BRUNO • CALIFORNIA

Export Agents: Frazer & Hansen, 301 Clay St., San Francisco, California

News—New Products

These manufacturers have invited PROCEEDINGS readers to write for literature and further technical information. Please mention your I.R.E. affiliation.

(Continued from page 66A)

reversed instantly, however, the complete stop-start cycle is programmed. Twelve seconds are required to reach full synchronous speed; eight seconds to stop. The rotor is energized with direct current in the synchronous run condition and the resulting torque is in excess of fifty-inch pounds. As a result, the rate-of-turn machine operation is extremely smooth. Output from the constant speed motor to the 24-inch cast aluminum table is infinitely variable through a ball-disc integrator drive from 0.01 to 1,200 degrees per second. Thirty-six turns of the single control are required for full-scale traverse.

Table capacity is 100 lbs. 108 $\frac{1}{4}$ inch-20 tapped mounting holes are arranged in a regular 2 inch equilateral pattern for mounting.

Write the manufacturer for detailed specification sheets.

Miniature Precision Potentiometer

Jet Electronics, Inc., 93 Massachusetts Ave., Boston, Mass., announces production of their new $\frac{1}{8}$ inch precision potentiometer, available with up to 360° electrical rotation as well as mechanical rotation, in resistance ranges up to 50,000 ohms (± 1 per cent). The weight is $\frac{1}{2}$ ounce.

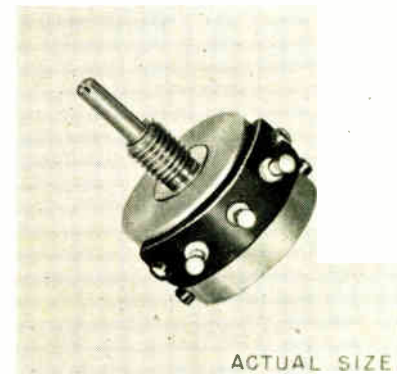

Cataloged as the D-100, it has an anodized aluminum case $\frac{7}{8}$ inch in diameter, with phosphor bronze bushing. A centerless, ground stainless steel shaft $\frac{1}{8}$ inch in diameter is supported by front and rear sleeve bearings (or ball bearings if specified). Paliney contact material is used between the rotor and resistance element. The rotor take-off brushes are made of gold alloy and rotate on a coin-silver ring. The manufacturer claims a life in excess of one million cycles.

Windings are available, with linearity guaranteed to within ± 1 per cent of total resistance. The units are rated at 1 watt at 25°C and the resistance alloy has temperature coefficient of 0.00002 parts/°C for values of 500 ohms or more. The ambient temperature rating is from -67°F to +250°F. Terminal board material withstands 250° F. Terminals are available with silver or gold plating.

(Continued on page 70A)

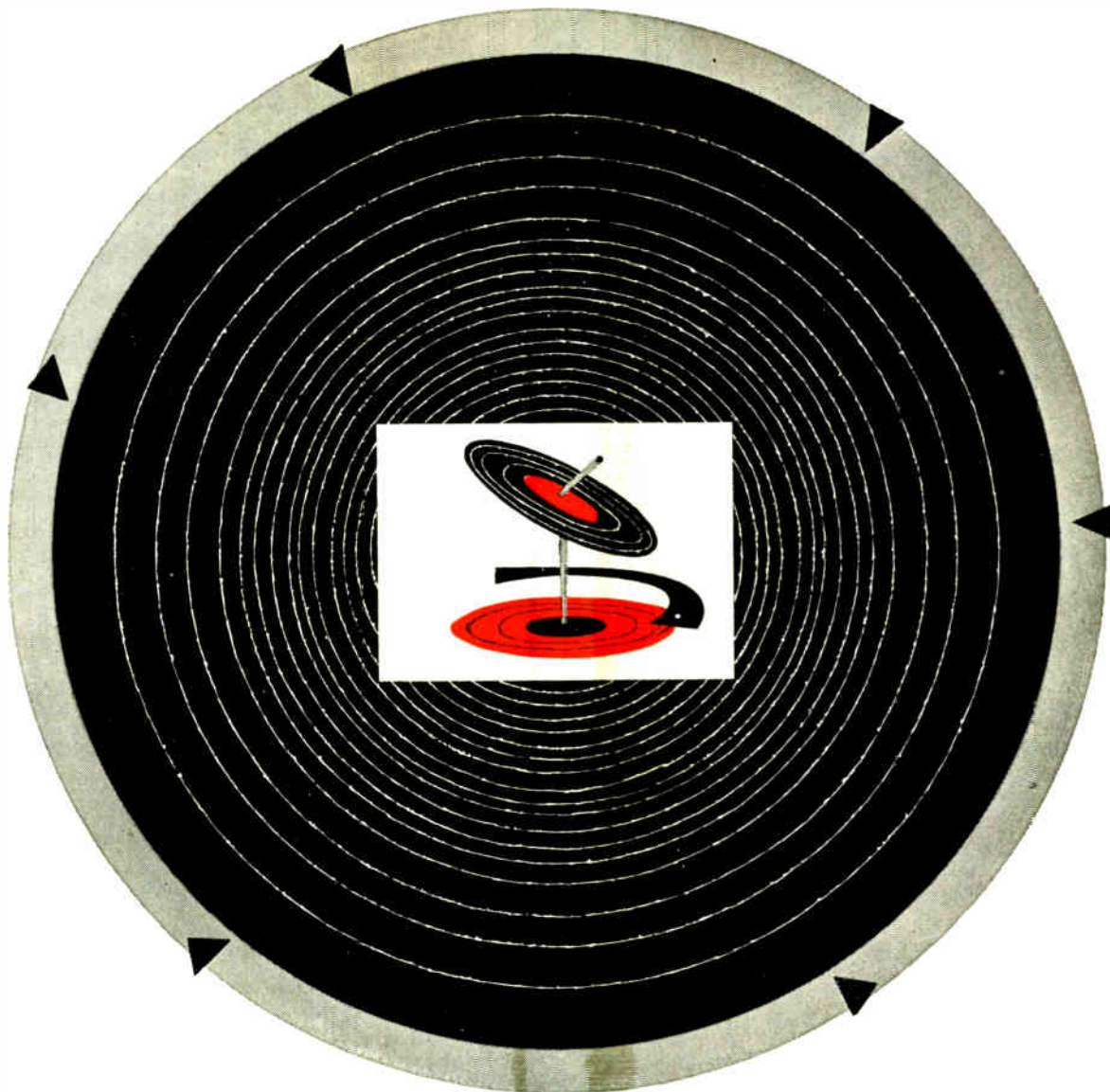

leading Hi-Fi producers specify **CRUCIBLE PERMANENT MAGNETS**
for maximum energy...minimum size

Crucible alnico permanent magnets are unsurpassed in their magnetic properties. They provide *consistently higher* energy product . . . which results in smaller, more powerful magnets.

That's why not only leading producers of high fidelity sound equipment, but hundreds of other discriminating manufacturers of instruments, controls, motors and other magnet-equipped devices, prefer Crucible alnico permanent magnets.

Crucible has been one of the largest producers of this type of magnet since the alnico alloys were first developed. And backing up this twenty-year magnet experience are 54 years of *quality* steelmaking. For highest quality alnico magnets and technical help in their application, *call Crucible.*



CRUCIBLE

first name in special purpose steels

54 years of **Fine** steelmaking

ALNICO PERMANENT MAGNETS

CRUCIBLE STEEL COMPANY OF AMERICA, GENERAL SALES OFFICES, OLIVER BUILDING, PITTSBURGH, PA.
REX HIGH SPEED • TOOL • REZISTAL STAINLESS • ALLOY • MAX-EL • SPECIAL PURPOSE STEELS

BOGUE



HI-CYCLE GENERATORS

For precision Hi-Cycle power generating equipment to meet one of a myriad of special power requirements ranging from highest quality laboratory power to precision electronic testing, industry relies on Bogue Precision Power. Bogue as the recognized leader in the Hi-Cycle field offers these performance characteristics—

LOW HARMONICS

CLOSE VOLTAGE REGULATION

400 CYCLE REGARDLESS OF LOAD & INPUT VARIATIONS

For example, Bogue special 400 cycle single shaft, two-bearing synchronous motor driven units eliminate belts, gears and other special speed changers, yet, faithfully deliver 400 cycles—exactly—no load to full load regardless of voltage variations . . . truly the standard of 400 cycle power . . . the reason so many prominent companies have been depending on equipment built by Bogue Electric Manufacturing Company . . .

The Authority on High Cycle Power

BOGUE

50 IOWA AVENUE • PATERSON 3, NEW JERSEY

Low harmonic 400 cycle AC generator and low ripple 28 volt DC generator, synchronous motor driven.

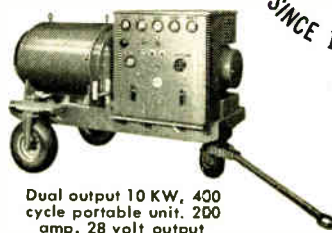
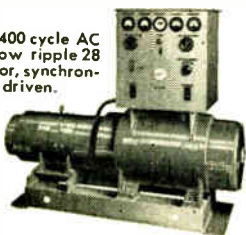

Dual output 10 KW, 400 cycle portable unit. 200 amp. 28 volt output

5 KW portable regulated 400 cycle motor-generator set with integral control panel.



Variable frequency 320 to 1000 cycle M-G set. Bogue magnetic amplifier maintains voltage and frequency to within one-half of 1% of any preset value.



5 KW low harmonic set. 400 cycle regardless of input voltage, loading or heating.

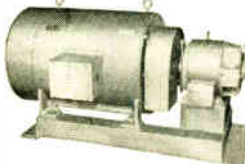

400 cycle voltage & frequency regulated inverter. Operates from 28 volt DC supply.

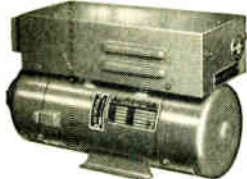

PRECISION ELECTRICAL EQUIPMENT
Bogue
SINCE 1892

REQUEST ILLUSTRATED CATALOG 440

News—New Products

These manufacturers have invited PROCEEDINGS readers to write for literature and further technical information. Please mention your I.R.E. affiliation.

(Continued from page 68A)

Power Supply



A new type of magnetic-amplifier-regulated power supply has been developed by the **Perkin Engineering Corp.**, 345 Kansas St., El Segundo, Calif. Identified as MR532-15, this unit is rated at 5–32 volts dc at 15 amperes and has a regulation accuracy of ± 1 per cent from 5 to 32 volts dc, from 1/10 full load to full load, from 105 to 125 volts ac. Its ripple voltage is 1 per cent rms at 32 volts at full load and its recovery time is 1/10 second. The unit is provided with a $4\frac{1}{2}$ -inch ammeter and voltmeter and is mounted in a bench-type cabinet which can also be used for 19-inch rack panel mounting by removing the panel from the cabinet.

The special features of this unit are, the fact that it has no tubes, is regulated and stabilized, is continuously variable, uses a choke input filter, and it has a magnetic type circuit-breaker on the dc side with time-delay provision for starting motors. Further information and literature can be obtained by writing the Perkin Corp.

Precision Delay Line

A laboratory-type delay line, variable in additive increments of 0.2 microsecond each, and used for electronic circuit work such as color television, instrumentation, pulse forming networks, computer circuits, is being manufactured by **May Engineering Co.**, 6055 Lankershim Blvd., N. Hollywood, Calif. This instrument is the lumped constant type with a total maximum delay of 1.0 microsecond measured at $\frac{1}{2}$ amplitude, with a rise time of 0.05 microseconds (measured at 10 per cent and



90 per cent amplitude). The characteristics impedance is 50, 75, or 100 ohms, and maximum peak voltage is 500.

(Continued on page 72A)

by
every
test



ATR AUTO
RADIO
VIBRATORS

Have Ceramic Stack Spacers
A COMPLETE LINE
OF VIBRATORS

Designed for Use in Standard
Vibrator-Operated Auto Radio
Receivers. Built with Precision
Construction, featuring Ceram-
ic Stack Spacers for Longer
Lasting Life. Backed by more
than 22 years of experience in
Vibrator Design, Develop-
ment, and Manufacturing.

Free



"A" Battery Eliminators, DC-AC
Inverters, Auto Radio Vibrators



NEW MODELS

NEW DESIGNS

NEW LITERATURE

See your jobber or write factory

AMERICAN TELEVISION & RADIO CO.

Quality Products Since 1931
SAINT PAUL 1, MINNESOTA—U. S. A.

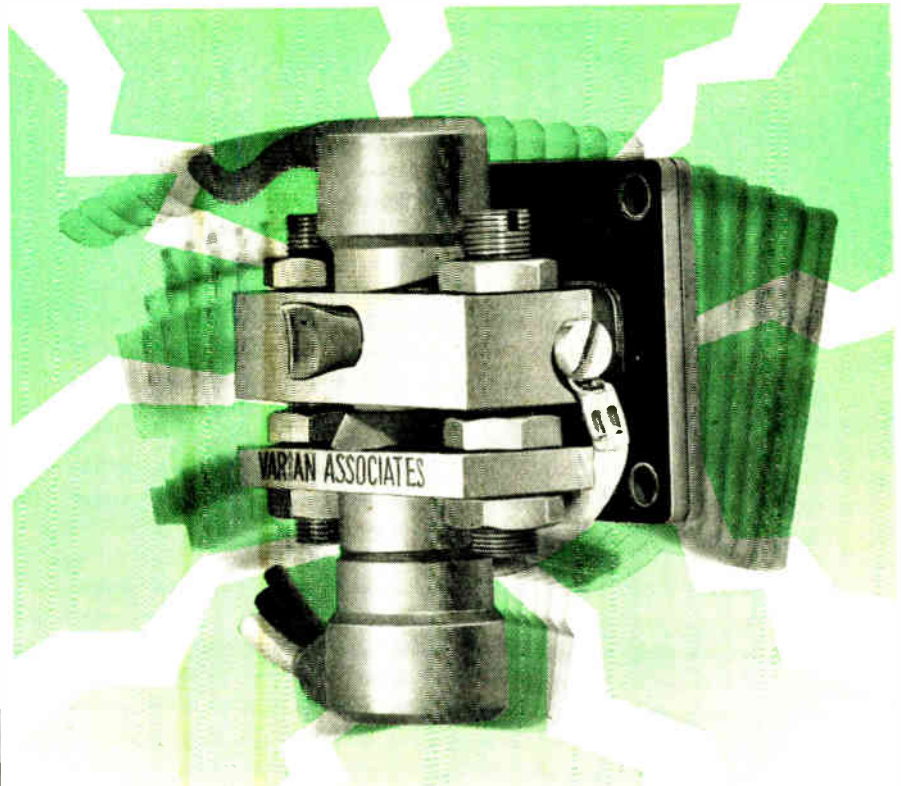

when the going gets

ROUGH

VARIAN klystrons can take it

The true test of a production klystron is the ability to operate successfully when subjected to severe vibration and shock under field conditions. That's why manufacturers of mobile radar insist on VARIAN klystrons—klystrons that stand up when the going gets rough.

VARIAN KLYSTRONS ARE RUGGED

Varian makes sure that its klystrons meet field performance requirements by testing each one under severe high amplitude vibration. This production test, accurately duplicating field conditions, is rough — so rough that ordinary klystrons can't take it.

VARIAN MEANS PROVED PERFORMANCE

From design to finished product, Varian builds quality into every klystron. And quality means dependability — the reason why leading system manufacturers specify Varian when klystron performance is a critical factor in the operational reliability of their product.

For rugged,
dependable,
production klystrons,
specify:

- VA-6310/V-260
- VA-6312/V-270
- VA-6313/V-280
- VA-6314/V-290
- VA-6315/V-153
- VA-6316/V-151



IN KLYSTRONS, THE MARK OF LEADERSHIP IS

VARIAN associates

PALO ALTO 2, CALIFORNIA

Representatives in all principal cities.

News—New Products

These manufacturers have invited PROCEEDINGS readers to write for literature and further technical information. Please mention your I.R.E. affiliation.

(Continued from page 70A)

This delay line is constructed so that the individual switches each control a step of 20 coils and 20 matched capacitors. Low attenuation is a feature of this unit. It is also produced in the distributed parameter type for high characteristic impedance. The over-all dimensions are $2\frac{1}{2} \times 3 \times 4\frac{1}{2}$ inches. These "Type A" precision delay lines are in production and priced at \$75.00.

In addition to the above, the same chassis is used and the steps are 0.05, 0.01, 0.15, 0.3, and 0.5 microsecond, to total 1.0 microsecond, thereby making it possible to switch in any delay from 0 to 1.0 microseconds in increments of 0.05. These are "Type B" precision delay lines, and are priced at \$90.00 each.

Single Side Band Adapter

Type 76 Single-Sideband Adapter manufactured by Crosby Laboratories, Inc., Box 233, Hicksville, L. I., N. Y., incorporates the new Burnell toroidal coil filters in place of the crystal filters used in the Type 51 Adapter.



One of the advantages claimed of the toroidal coil filter (Adapter) is the substantial reduction in cost as compared to the present crystal filter units, a factor that will accelerate the trend to the much superior single-sideband type of communication systems.

In addition to the reduced cost feature of the toroidal coil, this type filter is considerably smaller in size than the crystal filter, resulting in a saving in weight and chassis space. The unit is more suitable for field use where equipment may be subject to operation under shock and vibration conditions.

Moreover, since the Type 76 Adapter has none of the multiple crystals and L-C network circuits, alignment procedures are substantially eliminated.

For more complete information write to the firm direct.

Plant Expansion

Geo. Stevens Mfg. Co., Pulaski Rd. at Peterson, Chicago 30, Ill., has just completed an addition which doubles the area of the present modern plant. The new space is being used for manufacturing high-speed coil winders and for an enlarged engineering and design department.

(Continued on page 74A)

THE CORRECT COMBINATION OF SIZE AND POWER RATING offered by Jennings Vacuum Capacitors

The wide choice of size and power ratings for a given capacity range is illustrated by these four units all having maximum capacities of 1000 mmfd. JENNINGS functional designs thus permit you to select the smallest vacuum capacitor that will meet your voltage and current requirements.

Please let us suggest the capacitor that will best meet your specific circuit conditions.



UCSXF 10-1000
mmfd, 7.5, 10,
12 KV
60 amps rms



USCL 7-1000 mmfd, 3, 5 KV
42 amps rms



VMMC 50-1000 mmfd
10, 15 KV, 125 amps rms



VMMHC 60-
1000 mmfd
35, 40, 45 KV
125 amps rms

Literature mailed upon request

JENNINGS RADIO MANUFACTURING CORPORATION • 970 McLAUGHLIN AVE.
P.O. BOX 1278 • SAN JOSE 8, CALIFORNIA

FREED Instruments & Transformers

Famous For

QUALITY • DEPENDABILITY • ACCURACY



No. 1030
Low Frequency
"Q" Indicator



No. 1020B
Megohmmeter



Decade
Inductors



No. 1040
Vacuum Tube Voltmeter

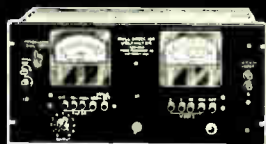

No. 1210
Null Detector &
Vacuum Tube Voltmeter



No. 1010
Comparison Bridge

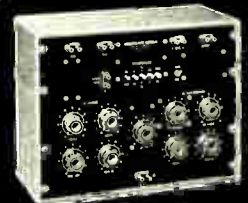

No. 1110A
Incremental Inductance
Bridge

FREED MINIATURE AUDIO TRANSFORMERS

PROFESSIONAL MINIATURE AUDIO TRANSFORMERS

These high quality, miniature transformers feature hermetic sealing for maximum protection from moisture penetration with subsequent electrolysis and corrosion of fine wires. While primarily intended for non-military equipment, these units are constructed in accordance with MIL-T-27 Specifications.

CATALOG NO.	APPLICATION	IMPEDANCE LEVEL OHMS		MAXIMUM POWER LEVEL V.U.*	RATIO	MAX PRI DC PER SIDE Ma.	D.C. UNBAL. Ma.	FREQ. RESPONSE C.P.S.	CASE NUMBER
		PRIMARY	SECONDARY						
PMA 1	Line or microphone to single or push-pull grids	50/200/500	60,000 C.T.	+8	1:11	0	0	±2.0 DB 30-20000	DM-12
PMA 2	Dynamic microphone or speaker voice coil to single or P.P. grid	4/8	60,000 C.T.	+8	1:86.6	0	0	±2.0 DB 30-20000	DM-12
PMA 3	Line or microphone to single or push-pull grids. Magnetically shielded.	50/200/500	60,000 C.T.	+8	1:11	0	0	±2.0 DB 30-20000	DM-12
PMA 4	Single triode plate to single or push-pull grids	15,000	60,000 C.T.	+8	1:2	0	0	±2 DB 30-10000	DM-12
PMA 5	Single triode plate to push-pull grids	15,000	60,000 C.T.	+8	1:2	2	2	±2 DB 200-10000	DM-12
PMA 6	Single triode plate to multiple line	15,000	50/200/500	+8	5.48:1	0	0	±2 DB 30-20000	DM-12
PMA 7	Single triode plate to multiple line	15,000	50/200/500	+8	5.48:1	2	2	±1 DB 200-10000	DM-12
PMA 8	Push-pull triode plates to multiple line	30,000 C.T.	50/200/500	+8	7.75:1	2	0.25	±2 DB 30-20000	DM-12
PMA 9	Crystal mike or pickup to multiple line	60,000	50/200/500	+8	11:1	0	0	±2 DB 30-20000	DM-12
PMA 10	Mixing or matching	50/200	50/200/500	+8	1:1.50	0	0	±2 DB 30-20000	DM-12
PMA 11	Parallel Feed Reactor * 1 mw. reference level.	40 hy.	3 ma dc,		3500 ohms	D.C. resistance			DM-12



DM-12 CASE DIMENSIONS

FL - 1 1/2
FD - 1 1/32
W - 15/16
H - 1 15/32
M - 1 7/32

Screws - 4-40
Cut out - 7/8
Wgt. - 1.5oz.

Send for complete catalog on
Freed Instruments and Transformers

FREED TRANSFORMER CO., INC.

1720 WEIRFIELD ST. (RIDGWOOD) BROOKLYN 27, N.Y.

World Radio History

News—New Products

These manufacturers have invited PROCEEDINGS readers to write for literature and further technical information. Please mention your I.R.E. affiliation.

(Continued from page 72A)

SHOW TEMPERATURE AT THE CONTROL PANEL



4 1/2" Cat. #4511

**WHITE
FACE**

3 3/4" Cat. #1654

2 1/2" Cat. #2613

**WARN OF
TROUBLE WHEN
IT STARTS — USE
SIMPLYTROL
INDICATING
PYROMETERS.**

Medium resistance pyrometers (4 ohms per millivolt). Automatic, bimetal cold junction correction. Compensated for copper error. With adjusting resistor to take thermocouples up to external resistance shown in table. When specified will be adjusted for mounting in steel panel. Accuracy 2%.

Contact pyrometers have same size and appearance but include contacts, adjustable to close at any place on the scale arc. Ask for Bulletin G-5.



4 1/2" Cat. #4514

**BLACK
FACE**

3 3/4" Cat. #1652

2 1/2" Cat. #2612

Model
B



Model
C

PORTABLES

Any of these pyrometers can be supplied in the Model B carrying case or in the Model C bench stand. Ask for Bulletin G-3.

Temperature Range Degrees	Int. Res.	Ext. Res.	Therma- couple	2 1/2 inch Size 261		3 3/4 inch Size 351		4 1/2 inch Size 451	
				Cat. No.	Price	Cat. No.	Price	Cat. No.	Price
0—3000° F 0—1650° C	70	10	Pt13%Rh	2618	\$19.90	1658	\$22.75	4518	\$30.25
0—2500 0—1370	212	10	C/A	2611	18.40	1651	21.25	4511	28.75
0—2000 0—1100	172	10	C/A	2616	18.40	1656	21.25	4516	28.75
0—1500 0—800	179	10	I/C	2612	18.40	1652	21.25	4512	28.75
0—1000 0—500	112	10	I/C	2615	19.50	1655	21.80	4515	29.90
0—750 0—400	81	10	I/C	2614	19.50	1654	22.45	4514	31.05
0—500 0—260	52	8	I/C	2613	20.10	1653	23.00	4513	32.20
—75 to 225 —60 to 110	30	5	I/C	2617	23.00	1657	26.50	4517	35.65
—200 to 100 —130 to 40	30	5	C/C	2619	29.00	1659	32.50	4519	41.65

Several intermediate ranges not listed.

Thermocouples:—(not included). Chromel-alumel (C/A) 14 ga. insulated 5' leads \$4.00. Iron-constantan (I/C) or copper-constantan (C/C) 20 ga. insulated 5' leads \$2.90.

ASSEMBLY PRODUCTS, INC., P. O. BOX 191, CHAGRIN FALLS 2, OHIO

Frequency Multiplier

Power Frequency Multipliers which change the frequency of line power without the use of rectifiers are now being produced D & R Ltd., 402 E. Gutierrez St., Santa Barbara, Calif. Units are hermetically sealed, and operate directly from a 400-cps, 3-phase power line, delivering 2,000-cps single phase output at a conversion efficiency of approximately 75 per cent.



The Model F-10 (illustrated) delivers 5 watts at 2,000 cps with good regulation, and with a harmonic content less than 7 per cent. The Model F-12 is only slightly larger than the F-10 yet delivers 25 watts at 2,000 cps, while the Model F-11 unit is capable of delivering 250 watts to the load with low harmonic content and an operating efficiency in excess of 80 per cent.

Relay Dust Cover

A new, low-cost, dust cover for their Model DOS Relay has just been announced by American Relay & Controls, Inc., 3645 Howard St., Skokie, Illinois.

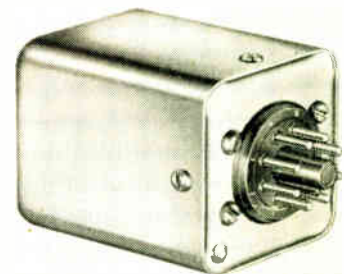

This component is a general-purpose relay that is light and compact but will handle relatively large power loads and is protected against dust. The plug-in mounting is also in line with the modern trend toward unit replacement.

The enclosure is of deep-drawn, one-piece aluminum, which fits snugly over the aluminum plate on which the relay and its plug-in base are mounted. No finishing is needed and, the enclosure will not rust.

(Continued on page 76A)

ARE YOU READY FOR

Guaranteed
Core Performance?



TAPE WOUND CORES

Are you ready for a revolutionary concept in the electrical and electronic industry—the Magnetics, Inc. "Performance-Guarantee" on Tape Wound Cores. Guaranteed

to meet your specifications, and sold at standard prices; these Cores mean truly economical production of high permeability magnetic devices in your plant.

TABLE A
BASIC PHYSICAL CONSTANTS OF
COMMON MAGNETIC MATERIALS

Trade Name	% Ni	% Fe	Other	Grain Structure	Satur. Flux Density Gausses	Resistivity Microhm-Cm	Curie Point °C	Dens. Grams per cc
Hy Mu 80	79	17	4 Mo	"random"	8,700	57	420	8.72
48 Alloy	48	52	...	"random"	16,000	45	500	8.3
Orthonol	50	50	...	oriented	15,500	45	500	8.25
Magnesil	97	3	Sr	oriented	20,000	48	700	7.65

TABLE B
TRADE NAMES OF SIMILAR MATERIALS

Hy-Mu 80	48 Alloy	Orthonol	Magnesil
4-79 Permalloy	Carpenter 49	Orthonik	Armco Oriented T
Mo-Permalloy	Atlegheny 4750	Permeron	Hypersil
Mu Metal*	Hypernik	Deltamax	Orthosil
		Hypernik V	Silectron

Typical of the unusual scope of the material contained in Catalog TWC-100 are Tables A and B, reproduced from Page 4 of "Performance-Guaranteed Tape Wound Cores."

GET THE COMPLETE STORY

A wealth of new and unusual material on Tape Wound Cores is available to you in Catalog TWC-100, "Performance-Guaranteed Tape Wound Cores." Tables A and B of the catalog, reproduced on this page, present a striking illustration of material not to be found compiled together elsewhere.

Data and descriptive details on high permeability materials . . . factory core matching . . . free engineering design services . . . pages of characteristic graphs and tables . . . are yours for the asking. Simply write on your company letterhead.



DEPT. I -7, BUTLER, PENNSYLVANIA

MODERN Problems Demand... MODERN SOLUTIONS

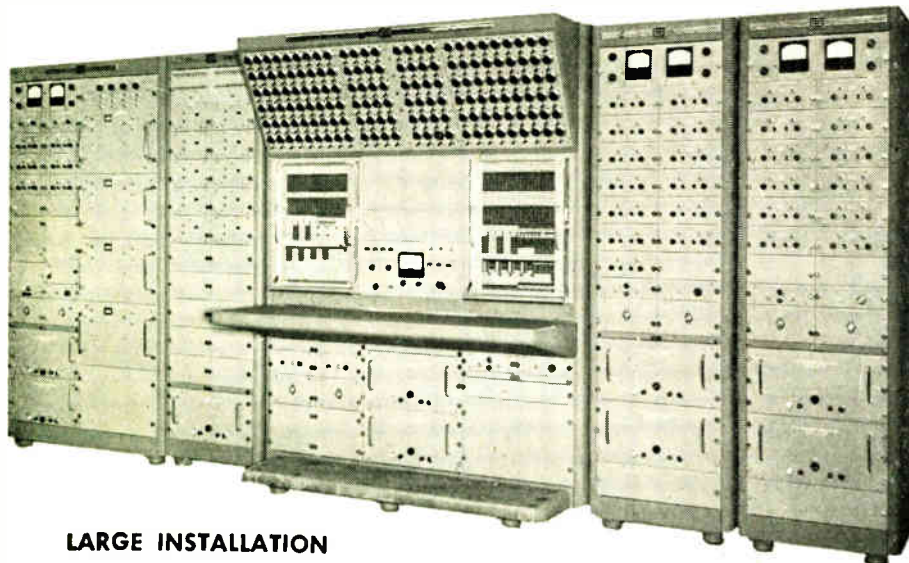

LARGE INSTALLATION

This large computer is used for the rapid solution of aero-dynamic problems. It consists of 50 operational amplifiers, 10 servo multiplying channels, 4 resolving channels, and a control console with two pre-patch bays, 156 attenuators, two voltmeters, and all necessary operational controls.

SINGLE PACKAGE COMPUTER

Our Type 16-31R Computer is a single package computer capable of solving differential equations with many simultaneous elements which are often encountered in the simulation of dynamic systems. It contains 20 operational amplifiers, 4 servo multipliers, thirty-two attenuators, all-metal removable problem board, and complete control panel.

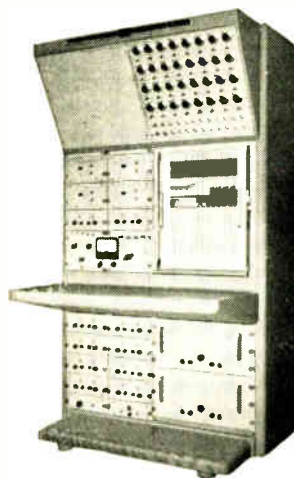
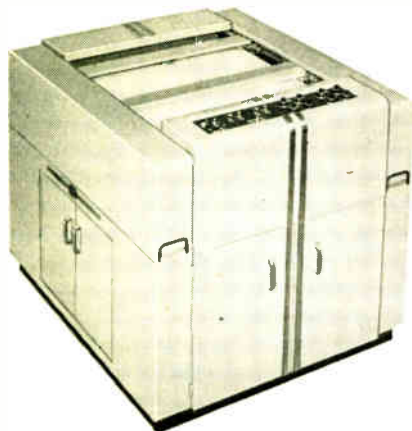

PLOTTING EQUIPMENT

For presentation of problem solutions, the Variplotter Plotting Boards provide an accurate inked record. Typical uses include the automatic plotting of: Analog Computer output; guided missile data; engine performance characteristics; and control of manufacturing processes. With accessory equipment the range of applications can be greatly extended.

Write Dept. IR



ELECTRONIC ASSOCIATES INC
LONG BRANCH • NEW JERSEY

News—New Products

These manufacturers have invited PROCEEDINGS readers to write for literature and further technical information. Please mention your I.R.E. affiliation.

(Continued from page 74A)

The enclosure can be removed for inspecting the relay.

The relay itself is Amrecon's Model DOS, which meets the rigorous standards for aircraft relays. The weight of relay and enclosure is seven ounces, and its dimensions are $2 \times 2 \times 2\frac{1}{2}$ inches high over-all, excluding the plug. Coil rating is 2.5 watts dc or 3.0 watts ac, with voltages up to 230 volts dc or 440 volts ac. Contact rating is 15 amperes at 115 volts ac or 32 volts dc, non-inductive.

Themistor-Type Temperature Indicator

Sensitivity and rapid response in temperature measurements are provided by the new Climate-Survey Temperature Indicators, developed by Beckman and Whitley, Inc., 963 E. San Carlos Ave., San Carlos, Calif. The basic instrument is available in three models, as follows: Model 196, six overlapping ranges spanning from -70° to $+60^{\circ}$ F; Model 197, six overlapping ranges spanning from 10° to 140° F; and Model 198, having a single range from 60° to 90° F.

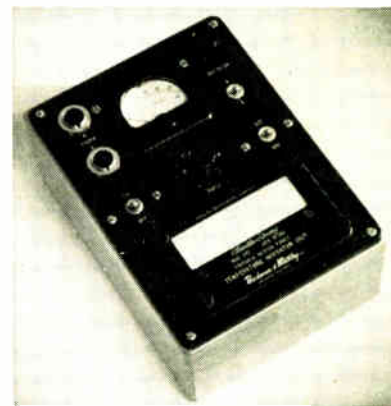

All are battery-operated and provide 500 hours of continuous operation.

Each instrument is provided with two input receptacles and a selector switch so that reference-temperature or wet- and dry-bulb readings can be made. Sensing elements can be located 800 feet from the instrument with standardized calibration, or with special calibration, cables as long as 8,000 can be used.

Direct-reading accuracy of all models is $\pm 0.5^{\circ}$ F through all ranges. Readings are made from a 3-inch square temperature-compensated meter at a response time of six seconds for 95 per cent of steady state condition.

Precision Phase Detector

Advance Electronics Co., P.O. Box 394, Passaic, N. J., has developed the Type 205 to meet the increasing need of a single instrument for detecting phase angle with error less than 0.1 degree in communication systems such as color television, and

(Continued on page 78A)

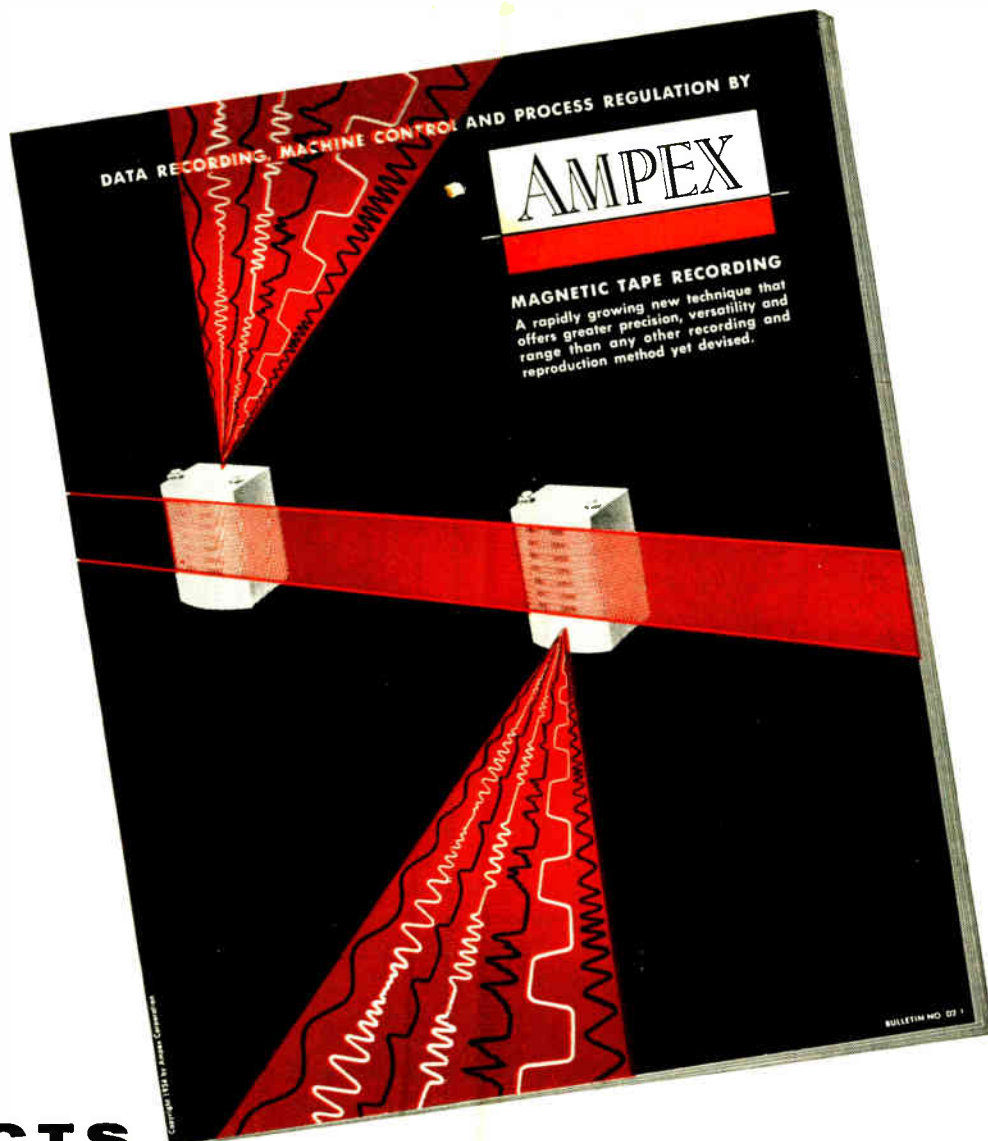

FACTS ON MAGNETIC RECORDING

the flexible "MEMORY" for science and industry

- In industry today magnetic recorders can "remember" and re-create the motions of skilled machinists, the forces encountered by a truck driving down a test road, the reflections from underground shock waves, the complex control of chemical processes.
- Magnetic recorders have long been at work recording complex data and reproducing it in its original electrical form — ready for automatic reduction and analysis.
- With greater accuracy and less cost than any other method, magnetic tape can "remember" situations encountered in your business — laboratory data, motions, processes and hundreds of kinds of information.

Get the facts in this important new bulletin from the company that has been building magnetic recorders for scientific purposes longer than any other firm. Written in clear, non-technical language, it tells what magnetic recording can do for you.



Send for your copy today; write Dept. G-1711

934 CHARTER STREET • REDWOOD CITY, CALIFORNIA

BRANCH OFFICES: New York, Chicago, Atlanta, San Francisco and College Park, Maryland (Washington D. C. area)

DISTRIBUTORS: Radio Shack, Boston; Bing Crasby Enterprises, Los Angeles; Southwestern Engineering & Equipment, Dallas and Houston; Canadian General Electric Company, Canada

Heiland

Amplifier System

The most complete, yet easiest to operate amplifier system ever developed for oscillographic recording

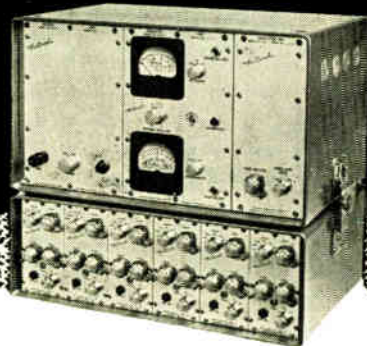

Model 119 Carrier and Linear or Integrating Amplifier System.

Heiland's model 119 Amplifier System, used in conjunction with Heiland Recording Oscillographs, has received wide acclaim from engineers for its extreme versatility, accuracy and simplicity of operation in the amplification of static and dynamic current phenomena.

This small, compact instrument, which can be provided for either rack, table, or shock mounting with available accessories, is housed in a rugged, yet lightweight cast aluminum case finished in attractive silver-gray gloss enamel. For complete specifications write or wire for our Bulletin 107.

Complete information on other Heiland products will be supplied on request.

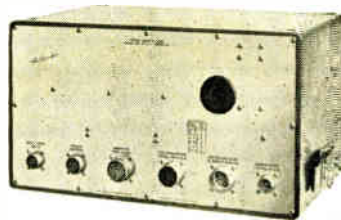

Power Supply Assembly (Rear View)



Amplifier Assembly (Rear View)

Heiland Research Corporation

130 East Fifth Ave.,
Denver, Colorado

News—New Products

These manufacturers have invited PROCEEDINGS readers to write for literature and further technical information. Please mention your I.R.E. affiliation.

(Continued from page 76A)

other communication networks at high frequencies. Essentially Type 205 consists of two cathode followers, a continuously variable delay line, a balanced phase detector, and a sensitive output indicator.

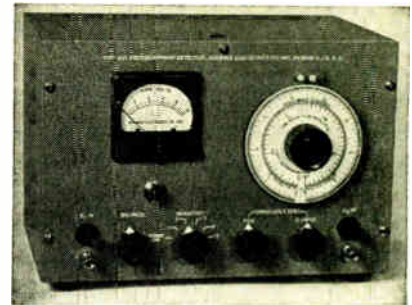

The accuracy is ± 0.1 degree (6 minutes) in phase reading, or ± 1 per cent of the time delay indicated on the dial of the continuously variable delay line. The frequency range is 10 kc to 10 mc. The lower limit may be extended to 1 kc with an additional delay line or phase shifting network. The upper limit may be extended with relaxing accuracy. The time delay of the two continuously variable delay lines which are supplied with the unit are 0 to 0.25 microsecond and 0 to 0.05 microsecond. Continuously variable delay lines with different time delay can be obtained upon request. The indicator sensitivity is 0.02, 0.04, shunted with $12 \mu\text{f}$ on both input channels. The price is \$445.00 each, F.O.B., Passaic.

24-Watt Amplifier

Allied Radio Corp., 100 N. Western Ave., Chicago 80, Ill., announces the release of a new 24-watt amplifier, the "Golden Knight." Frequency response at 24 watts output is ± 0.75 db from 20 to 40,000 cps. Harmonic distortion is less than 1 per cent at rated output; intermodulation distortion is less than 2 per cent at rated output.



The Knight amplifier has four inputs. One is for any high-impedance microphone; two inputs are for radio tuner, crystal cartridge, television, or tape recorder; another input takes General Electric, Pickering or Audak magnetic cartridges. Separate bass and treble tone controls, calibrated from -16 to $+16$ db are provided. Another feature is a three-

(Continued on page 116A)

COLOR TV demands

... exacting quality in capacitors and resistors



ERIE High Voltage Capacitors

Erie offers a wide selection of disc and molded type ceramicons for high voltage service up to 30 KV.

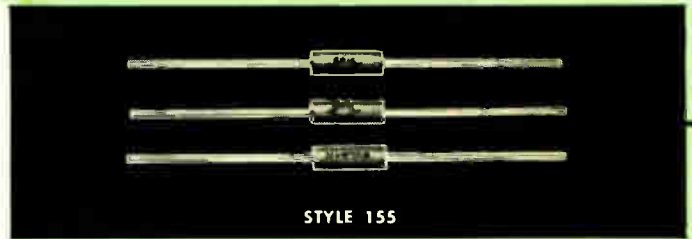

ERIE "Hi-Stab" Deposited Carbon Resistors

The Style 155 Pyrolytic resistor fulfills a long standing need for an extremely stable, moderately priced, molded insulated 1/2 watt resistor. Available from 100 ohms to 1/2 megohm in tolerances as close as $\pm 1\%$.

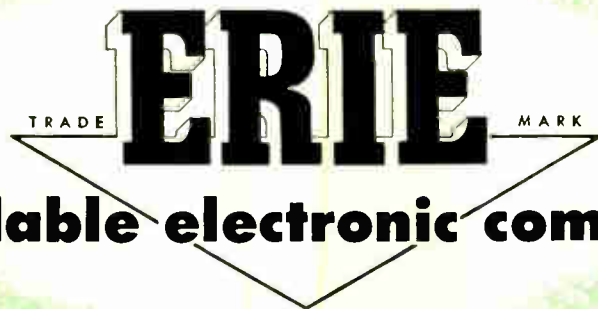

dependable electronic components

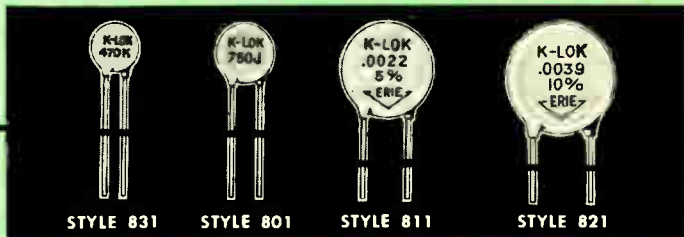

ERIE "K-LOK" High-stability Disc Ceramicons

Values up to .0047 mfd at 500 volts are available in tolerances as close as $\pm 5\%$. Capacity variations with temperature, age, and voltage are exceptionally small. A truly premium capacitor.



ERIE By-Pass and Compensating Ceramicons

To meet the exacting temperature compensation and by-pass requirements of color circuitry. Compensating units available from .75 to 1380 mmf. "Hi-K" by-pass units available from 100 mmf. to .01 mfd.



ERIE Trimmer Capacitors

The largest and most versatile family of plastic and temperature compensating ceramic trimmer capacitors are available from Erie, to meet difficult tuner and converter requirements.



ERIE Stand-off and Feed-thru Ceramicons

Manufactured in values up to 1500 mmf. to overcome radiation and critical by-passing problems.



ERIE RESISTOR CORPORATION . . . ELECTRONICS DIVISION

Main Offices and Factories: **ERIE, PA.**

Sales Offices: Cliffside, N. J. • Philadelphia, Pa. • Chicago, Ill. • Detroit, Mich.

Ashland, Ohio • Fort Wayne, Ind. • Los Angeles, Calif. • Toronto, Ontario

Manufacturing Subsidiaries:

HOLLY SPRINGS, MISS. • LONDON, ENGLAND • TRENTON, ONTARIO

How RCA Makes

RCA Receiving Tubes

YOUR BEST BUY

BEST BECAUSE...

Special mica insulator processing—minimizes picture "jitters" caused by charging effects and leakages

BEST BECAUSE...

Gold-plated Grid No. 1—minimizes grid emission

BEST BECAUSE...

Carbonized Grid No. 2 runs cooler, reduces stray emission

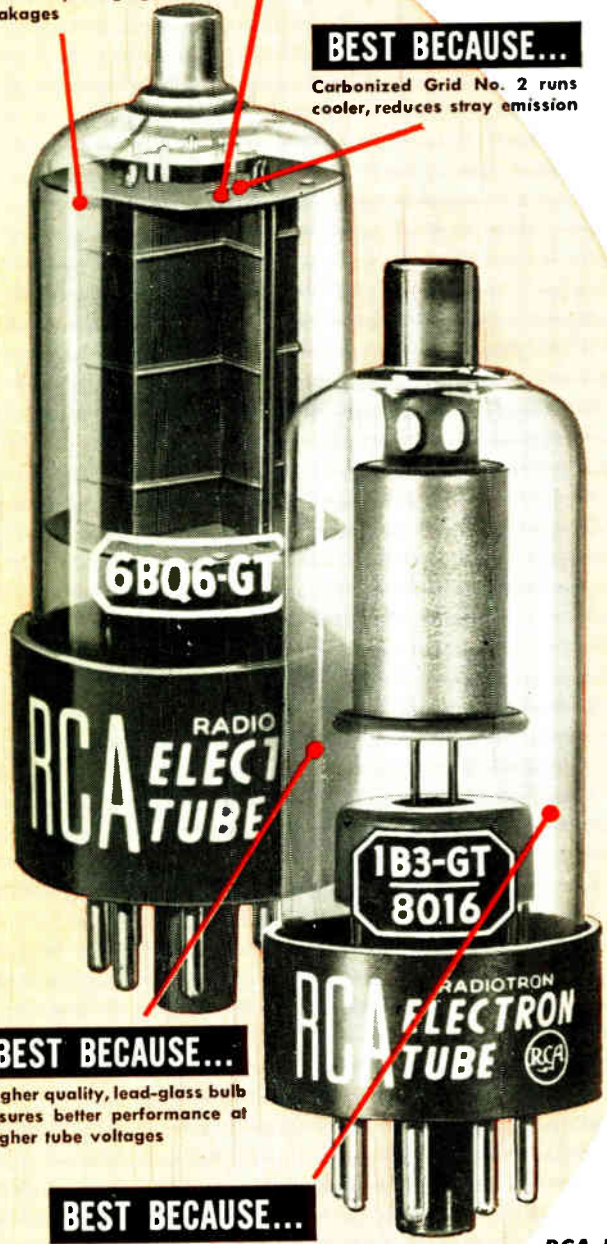

BEST BECAUSE...

Higher quality, lead-glass bulb insures better performance at higher tube voltages

BEST BECAUSE...

Specially processed glass bulb minimizes electrolysis, improves tube life

You get more for your money when you buy RCA receiving tubes because RCA makes extra effort to keep pace with new requirements for tube applications. For instance, the 1B3-GT and 6BQ6-GT illustrate how RCA makes improvements in tube type designs . . . makes RCA receiving tubes best for top performance in your TV-receiver designs.

The RCA-1B3-GT rectifier has been improved to handle the higher voltages required by "big-picture" TV sets. Tube safety factors have been increased.

The RCA-6BQ6-GT horizontal output tube is another improved tube. Its improvements minimize grid emission, stray emission, and TV picture "jitters."

The improvements built into RCA receiving tubes give you: (1) Superior tube performance, (2) fewer factory-line rejects and "in-warranty" failures, (3) substantially greater tube value.

For circuit application help, call your nearest RCA Field Office:

- (EAST) Humboldt 5-3900
415 S. 5th St., Harrison, N. J.
- (MIDWEST) Whitehall 4-2900
589 E. Illinois St., Chicago 11, Ill.
- (WEST) Madison 9-3671
420 S. San Pedro St., Los Angeles 13, Cal.

FOR COLOR-TV, SPECIFY RCA TUBES

RCA PIONEERED AND DEVELOPED COMPATIBLE COLOR TELEVISION



RADIO CORPORATION of AMERICA
ELECTRON TUBES **HARRISON, N. J.**

BOARD OF DIRECTORS, 1954

William R. Hewlett
President

M. J. H. Ponte
Vice-President

W. R. G. Baker
Treasurer

Haraden Pratt
Secretary

John R. Pierce
Editor

D. B. Sinclair
Senior Past President

J. W. McRae
Junior Past President

1954

- A. N. Goldsmith
- J. T. Henderson (R8)
- A. V. Loughren
- C. A. Priest (R4)
- J. R. Ragazzini (R2)
- J. D. Ryder
- A. W. Straiton (R6)
- J. A. Stratton
- Ernst Weber

1954-1955

- S. L. Bailey
- C. J. Marshall (R5)
- L. E. Packard (R1)
- J. M. Pettit (R7)
- B. E. Shackelford
- H. W. Wells (R3)

1954-1956

- A. G. Jensen
- George Rappaport

George W. Bailey
Executive Secretary

John B. Buckley
Chief Accountant

Laurence G. Cumming
Technical Secretary

Evelyn Davis
Assistant to the Executive Secretary

Emily Sirjane
Office Manager



Responsibility for the contents of papers published in the PROCEEDINGS OF THE I.R.E. rests upon the authors. Statements made in papers are not binding on the Institute or its members.



PROCEEDINGS OF THE I.R.E.[®]

Published Monthly by

The Institute of Radio Engineers, Inc.

VOLUME 42

May, 1954

NUMBER 5

THE PROCEEDINGS OF THE I.R.E.

Julius A. Stratton, Director, 1954.....	784
The Engineering Report.....	Frank G. Kear 785
4920. Frequency Variations of Junction-Transistor Parameters.....	R. L. Pritchard 786
4921. Electron Beam Focusing with Periodic Permanent Magnet Fields.....	J. T. Mendel, C. F. Quate, and W. H. Yocom 800
4922. Antenna and Receiver Measurements by Solar and Cosmic Noise.....	Jules Aarons 810
4923. IRE Standards on American Recommended Practice for Volume Measurements of Electrical Speech and Program Waves, 1953.....	815
4924. A Gas-Discharge Noise Source for Eight-Millimeter Waves.....	T. J. Bridges 818
4925. Transient Response in FM.....	Igor Gumowski 819
4926. Unit Construction Practice (UCP) Applied to Line-Transmission Equipment.....	Kenneth W. Harrison 822
4927. Switching Time in Junction Diodes and Junction Transistors.....	Robert H. Kingston 829
4928. Bounds Existing on the Time and Frequency Responses of Various Types of Networks.....	Armen H. Zemanian 835
4929. Matrix Analysis of Multi-Terminal Transducers.....	Jacob Shekel 840
4930. Prolonged Space-Wave Fadeouts at 1,046 MC Observed in Cheyenne Mountain Propagation Program.....	Bradford R. Bean 848
4931. Correction to "Information Cells on Intensity-Modulated CRT Screens".....	Daniel Levine 853
4932. Antenna Scattering Measurements by Modulation of the Scatterer.....	H. Scharfman and D. D. King 854
Correspondence:	
4933. "Improvement of Power Output from Pulsed Klystrons".....	John H. Jasberg 859
4934. "A Simple Graphical Analysis of a Two-Port Waveguide Junction".....	G. A. Deschamps 859
4935. "One Way Transmission Devices".....	Allen E. Smoll 860
4936. "Stretched-Log Frequency Axis".....	Harry Stockman 860
4937. "A New Method of Driving-Point Impedance Synthesis".....	R. H. Pantell 861
4938. "The Effect of Space Charge on Beam Loading in Klystrons".....	T. G. Mibran 862
Contributors to the PROCEEDINGS OF THE I.R.E.....	863

IRE NEWS AND RADIO NOTES SECTION

1954 IRE Radio Engineering Show.....	864
1954 IRE Annual Meeting.....	865
1954 IRE National Convention.....	866
IRE Awards, 1954.....	868
New Fellows.....	870
Convention Record of the I.R.E.....	879
International Convention to Be Held This Spring.....	880
Technical Committee Notes.....	881
Professional Groups.....	881
Sections.....	882
4939. Abstracts and References.....	884
Index to TRANSACTIONS OF THE I.R.E., 1953.....	Follows page 898
Meetings with Exhibits.....	2A Student Branch Meetings... 105A
News—New Products.....	14A Membership..... 112A
Industrial Engineering Notes.....	82A Positions Open..... 130A
Professional Group Meetings.....	90A Positions Wanted..... 136A
Section Meetings.....	98A Advertising Index..... 166A

EDITORIAL DEPARTMENT

Alfred N. Goldsmith
Editor Emeritus

John R. Pierce
Editor

E. K. Gannett
Managing Editor

Marita D. Sands
Assistant Editor

ADVERTISING DEPARTMENT

William C. Copp
Advertising Manager

Lillian Petranek
Assistant Advertising Manager

EDITORIAL BOARD

John R. Pierce, *Chairman*

- D. G. Fink
- E. K. Gannett
- T. A. Hunter
- J. W. McRae
- J. A. Stratton
- W. N. Tuttle

Changes of address (with advance notice of fifteen days) and communications regarding subscriptions and payments should be mailed to the Secretary of the Institute, at 450 Ahnaip St., Menasha, Wisconsin, or 1 East 79 Street, New York 21, N. Y.

All rights of publication, including translation into foreign languages, are reserved by the Institute. Abstracts of papers with mention of their source may be printed. Requests for republication privileges should be addressed to The Institute of Radio Engineers.



Julius A. Stratton

DIRECTOR, 1954

Julius A. Stratton was born on May 18, 1901 in Seattle, Washington. He received the B.S. degree in electrical engineering from the Massachusetts Institute of Technology in 1923 and spent the following year in study in France. He returned to M.I.T. to become Research Assistant in the newly-established Communications Laboratory under the direction of Professors Arthur E. Kennelly and E. L. Bowles, and in 1925 he received the M.S. degree in electrical engineering. In 1927 he was awarded the D.Sc. degree in mathematical physics from the Technische Hochschule in Zurich, and he remained in Europe on an M.I.T. traveling fellowship, studying under Professor Sommerfeld in Munich, until the Fall of 1928. He then became Assistant Professor in the Department of Electrical Engineering at M.I.T. In 1931 he transferred to the Department of Physics, becoming full Professor in 1941, and in 1945 he assumed Directorship

of the Research Laboratory of Electronics at M.I.T. Dr. Stratton was appointed Provost in 1949, and is currently Vice President and Provost at M.I.T.

During World War II Dr. Stratton was a Staff Member of the Radiation Laboratory, Expert Consultant in the Office of the Secretary of War, and received the Medal for Merit in 1946. From 1946 to 1949 he was Chairman of the Committee on Electronics of the Joint Research and Development Board.

Dr. Stratton became a Member of the IRE in 1942, a Senior Member in 1943, and was elected a Fellow in 1945. He served as a Director from 1948-1951. He is currently on the Editorial Board.

Dr. Stratton is a member of the National Academy of Sciences, the American Physical Society, the American Academy of Arts and Sciences, Zeta Psi, Tau Beta Pi, and Sigma Xi.

The Engineering Report

FRANK G. KEAR

One important link between the engineer and his professional and commercial associates is the Engineering Report. Its significance and helpfulness are often underestimated, and its preparation is occasionally and regrettably neglected. Many readers of these PROCEEDINGS will accordingly benefit from the following helpful analysis of report preparation by a Fellow of the Institute, who is a consulting engineer and a member of Kear & Kennedy, of Washington, D. C.—*The Editor*.

The trade mark of the engineer is, by common acceptance, the slide rule, an instrument also generally assumed to be his most important tool. There is, however, a tool even more basic to an engineer, but one which is frequently neglected: this is the Engineering Report.

From the beginning of his professional education, the engineer receives training in the writing of reports. Many of these are in the nature of laboratory reports on specific tests, but a large number cover the investigation of more general problems. Familiarity with the framework of these reports is vital to clearly organized thinking, and only by means of such reports can the engineer adequately present the results of his work. Upon completion of his formal education, the engineer is often prone to overlook the continuing need for using the report framework as part and parcel of his thinking, with the result that much effort and time expended in performing work is lost to industry because of failure to prepare an adequate and complete presentation. Unless an engineer can convey to his management or his client a correct and adequate presentation of the work which he has performed, he has failed in his obligations.

Since the PROCEEDINGS OF THE I.R.E. constitutes the media whereby engineering information is disseminated within the profession, it seems appropriate that it include in its pages a reminder of the importance of the proper use of the engineering report.

The basic report outline is simple enough, having only five subdivisions—(1) the statement of the problem, (2) the facts bearing upon the problem, (3) an analysis and discussion of these facts, (4) the conclusions drawn therefrom, and (5) recommendations. Let us consider these.

(1) Formulation of a correct statement of the problem presented is obviously fundamental, yet frequently overlooked. The engineer must take ample time to determine exactly what is required of him in order that no time is wasted on issues which are not relevant. The statement should be reduced to writing before any work is begun.

(2) The facts bearing upon the problem should be carefully marshalled and great care taken to include every pertinent fact which the engineer will use. By so doing it becomes a simple matter at a later date to look back and determine the reasons for a recommended course of action. Frequently an engineer finds it advisable to change his recommendations materially because of the discovery of facts not originally considered. Reference to the original report will immediately disclose the absence of these new

facts, the inclusion of which would justify the change in recommended action.

(3) The analysis and discussion of the facts will vary greatly in size and format, depending on the type of problem. It could run into several notebooks dull of pertinent information and data, or it may be a mere paragraph. If the analysis is lengthy, it should be reduced to summary form for inclusion in the report. However, brevity should not be favored at the expense of clarity of exposition.

(4) The conclusions reached after completion of the analysis should be stated concisely and clearly, pointing out the line of reasoning employed in reaching these conclusions and, of course, making certain that this reasoning is substantiated by the preceding portions of the report. This subdivision must be carefully limited to the conclusions of the engineer making the report. It should not contain any new material previously undisclosed, nor should it duplicate material which will be included in the fifth subdivision. Many engineering reports will close at this point. The average paper published in the PROCEEDINGS customarily contains these four subdivisions.

(5) The last and most important subdivision, although as in the case of a paper for the PROCEEDINGS it is not always required, is the one containing recommendations. The person or group to whom this report is made is customarily interested only in this last paragraph. It must contain clear and concise recommendations as to the proper course of action to be taken as a result of the engineering work which has been performed. Brevity is desirable. The context should not be confused by quotations from previous portions of the report. The ability to present this paragraph properly represents the dividing line between the technician and the professional engineer. When an engineer is assigned a task the presumption is that he is competent to perform this task. Accordingly, he should not waste time and space in establishing this competency. The recipient of the report merely wants to know what he should do and how he should do it. The recommendations should therefore be limited to simple, clearly-worded sentences, avoiding multiple or conflicting recommendations unless the writer clearly indicates the relative merits of each.

If the engineer follows carefully the foregoing outline in each problem presented to him, he will find his work is simplified, his reports present a permanent record of the project, and management or the client will have the necessary information on which to base their action.

Frequency Variations of Junction-Transistor Parameters*

R. L. PRITCHARD†, ASSOCIATE, IRE

Summary—A Theoretical solution for the frequency variation of the four small-signal parameters of a junction transistor has been obtained by extending Shockley's analysis and by taking account of space-charge-layer widening as suggested by J. M. Early. From the results of this solution, it has been possible to explain the experimentally observed frequency variation of open-circuit collector-base admittance of fused-junction $p-n-p$ junction transistors that was reported earlier and is described here in more detail. The theoretical frequency variation of the current-amplification factor and of the other two small-signal parameters (open-circuit voltage-feedback factor h_{12} and short-circuit input impedance h_{11} , for the grounded-base connection) also is discussed in some detail. Numerical results are included for each of the four parameters in the form of curves of normalized parameters versus relative frequency. Derivation of the voltage-current relations for the theoretical model is given separately in section II. The effect of base-spreading resistance is taken into account in the usual manner by addition of a lumped resistance to the base contact of the theoretical model.

INTRODUCTION

FROM AN electric-circuit point of view, a transistor may be considered as an active four-terminal network, the behavior of which may be described by four parameters. One of the most commonly used sets of parameters for the junction transistor comprises the elements of an equivalent-Tee network¹ as shown in Fig. 1. The four parameters in this representation are the emitter resistance r_e , the base resistance r_b , the parallel combination of collector resistance r_c and collector capacitance C_c , and the effective current-amplification factor α_e . For small-signal linear operation of the transistor, the four parameters are considered as constants determined by the dc operating point.

The frequency variation of the current-amplification factor has been discussed in some detail.² On the other hand, it had been a popularly accepted fact that the other three parameters were independent of frequency.³

* Decimal classification: R282.12. Original manuscript received by the IRE, September 18, 1953. Presented at the Semiconductor Symposium of the Electrochemical Soc. Meeting, New York, N. Y., April 15, 1953, and at the Transistor Research Conference, State College, Pa., July 6, 1953. The research was supported by the Government Tri-Services Contract AF 33(600) 17793, Semiconductors.

† Communications Research Section, Genl. Elec. Research Lab., Schenectady, N. Y.

¹ See, for example, R. L. Wallace and W. J. Pietenpol, "Some circuit properties and applications of $n-p-n$ transistors," *Proc. I.R.E.*, vol. 39, Fig. 26, p. 765; July, 1951. Also *Bell Sys. Tech. Jour.*, vol. 30, p. 558; July, 1951. The voltage generator shown in their Fig. 26 can be replaced in a straightforward manner by the current generator shown in Fig. 1 above.

² See: a) W. Shockley, M. Sparks, and G. K. Teal, " $p-n$ junction transistors," *Phys. Rev.*, vol. 83, section IX, p. 161; July 1, 1951, b) R. L. Pritchard, "Frequency variations of current-amplification factor for junction transistors," *Proc. I.R.E.*, vol. 40, pp. 1476-1481; November, 1952, c) D. E. Thomas, "Transistor amplifier—cut-off frequency," *ibid.*, pp. 1481-1483.

³ This is based on experience with point-contact transistors for which the three resistive parameters of the Tee network were found to be essentially independent of frequency up to several mc. See J. A. Becker and J. N. Shive, "The transistor—a new semiconductor amplifier," *Elec. Eng.*, vol. 68, p. 221; March, 1949, or J. Bardeen and W. H. Brattain, "Physical principles involved in transistor action," *Bell Sys. Tech. Jour.*, vol. 28, p. 258; April, 1949; also in *Phys. Rev.*, vol. 75, pp. 1215-1216; April 15, 1949.

However, on the basis of a theoretical study of the junction transistor, J. M. Early pointed out that both r_e and r_b also may vary with frequency. In fact, there is both a high-frequency and a low-frequency value for each of these parameters. Further frequency effects were not considered by Early.⁴

During the initial stages of an investigation of the electric-circuit properties of fused-junction $p-n-p$ junction transistors developed by Saby⁵ it was found that collector resistance r_c decreased with increasing frequency. Decreases of the order of a factor of 10 from the low-frequency value were observed. Subsequently, S. K. Ghandhi⁶ found that the collector capacitance also decreased with increasing frequency.

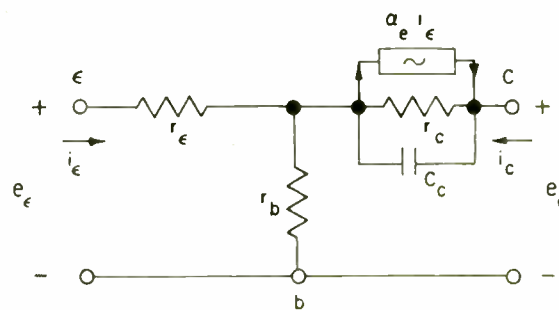

Fig. 1—Equivalent-tee circuit for junction transistor.

By extending Early's analysis to include frequency effects, it has been possible to explain the observed behavior of the collector impedance with frequency. Frequency variations of the other three parameters also have been calculated. The results of the theoretical analysis for the frequency variations of the four parameters are presented in the first section of the paper together with experimental results for the collector-base impedance. Calculation of the voltage-current relations for the theoretical model of the transistor from physics of the structure is given separately in section II.

I. FREQUENCY VARIATION OF SMALL-SIGNAL PARAMETERS

There are a large number of small-signal parameters that may be calculated for a junction transistor, e.g., either grounded-base, grounded-emitter, or grounded-collector operation may be considered, and six sets of parameters may be calculated for each connection. However, if any four *independent* parameters are known,

⁴ a) J. M. Early, "Effects of space-charge layer widening in junction transistors," *Proc. I.R.E.*, vol. 40, pp. 1401-1406; November, 1952.

b) Since submission of this paper for publication Early has written, "Design theory of junction transistors," *Bell Sys. Tech. Jour.*, vol. 32, pp. 1271-1312; November, 1953.

⁵ J. S. Saby, "Recent developments in transistors and related devices," *Tele-Tech*, vol. 10, p. 34; December, 1951. See also, J. S. Saby, "Fused impurity $p-n-p$ junction transistors," *Proc. I.R.E.*, vol. 40, pp. 1358-1360; November, 1952.

⁶ S. K. Ghandhi, Electronics Laboratory, Syracuse, N. Y., personal communications, March, 1952.

any of the other parameters may be calculated. From the point of view of simplicity of presentation, this writer prefers to use the series-parallel, or $[h]$, parameters for the grounded-base connection of the transistor. These are defined by the equations⁷

$$\left. \begin{aligned} e_1 &= h_{11}i_1 + h_{12}e_2 \\ i_2 &= h_{21}i_1 + h_{22}e_2 \end{aligned} \right\} \quad (1)$$

There also are other advantages of using these parameters, e.g., in general they are the most easily measured quantities for the junction transistor, which has a low input impedance and a high output impedance.

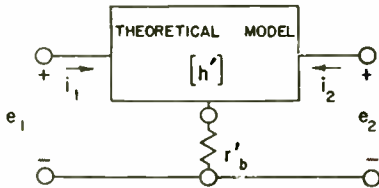

Fig. 2—Effect of adding base spreading resistance to theoretical model for junction transistor.

The current-voltage relations for the theoretical model of the transistor are obtained in the form $[i] = [y] \cdot [e]$, i.e., the admittance parameters are calculated. However, when the effect of the resistance of the base region is taken into account in the usual manner by adding an external resistance in series with the base contact to the theoretical model, the $[y]$ representation becomes somewhat more complicated. Accordingly, the four $[h]$ parameters for the theoretical transistor have been calculated from the $[y]$ parameters and are given in (59)–(63) of section II. In this section the parameters of the theoretical model will be characterized by primes, e.g., h_{11}' . When the base spreading resistance r_b' is added to the theoretical model as shown in Fig. 2, the $[h]$ parameters of the over-all transistor are given by the matrix equation (2).

$$[h] = \begin{bmatrix} h_{11}' + \frac{r_b'(1 + h_{21}')}{(1 + r_b'h_{22}')} & \frac{h_{12}' + r_b'h_{22}'}{(1 + r_b'h_{22}')} \\ \frac{h_{21}' - r_b'h_{22}'}{(1 + r_b'h_{22}')} & \frac{h_{22}'}{(1 + r_b'h_{22}')} \end{bmatrix} \times \begin{bmatrix} i_1 \\ e_2 \end{bmatrix} \quad (2)$$

It turns out that the output-admittance parameter h_{22} is least affected by the addition of r_b' , whereas the feedback parameter h_{12} is most affected. Next most affected is the input impedance h_{11} , and third most affected is the current-amplification factor h_{21} ($= -\alpha$). Each of the four parameters will be discussed in detail below.

A. Current-Amplification factor h_{21}

1. Theoretical model:

$$-h_{21}' = \alpha' = \gamma \cdot \beta. \quad (3)$$

⁷ See, for example, E. A. Guillemin, "Communication Networks," vol. II, chap. IV, John Wiley & Sons, New York, N. Y., 1935. Also J. S. Brown and F. D. Bennett, "The application of matrices to vacuum-tube circuits," PROC. I.R.E., vol. 36, p. 845; July, 1948. Note however that Guillemin considers the special case of a bilateral network; hence most of his results are not directly applicable here.

For a junction transistor with a simple $p-n$ junction collector, current-amplification factor α' may be written^{2a} as the product of two factors γ and β . Emitter efficiency γ is the ratio of minority-carrier current (hole current for $p-n-p$ transistor) into the base from the emitter junction to the total emitter current. Thus, the departure of γ from unity is a measure of undesired current from the base to the emitter (electron current for a $p-n-p$ transistor), plus the reactive current through the capacity of the emitter-base junction. The factor β is that fraction of the minority-carrier current from the emitter that reaches the collector.

The frequency variation of β has been discussed^{2a,b} previously and will be reviewed here only briefly. If the low-frequency value β_0 is unity, the frequency variation of β may be described by the expression

$$\beta = \operatorname{sech} (j\omega\tau_D)^{1/2}$$

where τ_D is a diffusion time for carriers in the base, i.e., a built-in transit time. The β -cut-off frequency $\omega_c/2\pi$ is defined as the frequency for which $|\beta|^2$ has decreased to $\frac{1}{2}$. This occurs for $\omega\tau_D = 2.43$. In terms of the thickness w expressed in mils (10^{-3} inch) of the base region of the transistor, ω_c may be calculated from the expression^{2b}

$$(\omega_c/2\pi) = \begin{cases} 5.6 \times 10^6/w^2 & \text{for an } n-p-n \text{ Germanium unit} \\ 2.6 \times 10^6/w^2 & \text{for a } p-n-p \text{ Germanium unit.} \end{cases} \quad (4)$$

If β_0 is different from unity, the term $j\omega\tau_D$ must be replaced by a complex variable. However, an excellent approximation for β in this case is simply

$$\beta = \beta_0 \operatorname{sech} (j\omega\tau_D)^{1/2}, \quad (5)$$

with

$$\tau_D \equiv 2.43/\omega_c, \quad (6)$$

where the β -cut-off frequency $\omega_c/2\pi$ is defined as the frequency for which $|\beta|^2/\beta_0^2$ has decreased to $\frac{1}{2}$. Exact values of β/β_0 as a function of ω/ω_c have been calculated and have been found to be in excellent agreement with respect to both phase and amplitude with values calculated from the approximate equation (5) and (6). However, in general, the relation between ω_c and w is a function of β_0 . (This would be of consequence only if ω_c were to be calculated accurately from a measured value of w .) Numerical values of ω_c as a function of w and β_0 are given in Appendix A.

On the other hand, the frequency variation of the emitter efficiency γ cannot be described in such simple terms. In general, three parameters plus the parameter τ_D (or ω_c) introduced above for β , are necessary to define γ at all frequencies. A useful approximate expression for γ may be written as

$$\gamma = \left\{ 1 + [A(1 + j\omega\tau_e)^{1/2} + (j\omega C_e' r_e'/\gamma_0)] \cdot [\tanh (j\omega\tau_D)^{1/2}/(j\omega\tau_D)^{1/2}] \right\}^{-1}. \quad (7)$$

Here A is a parameter involving relative concentrations of minority carriers in base and emitter regions, base thickness w , and the parameter τ_e , which is a second

characteristic time constant of the transistor (lifetime of minority carriers in the emitter). Alternatively, A may be defined in terms of the low-frequency value γ_0 of γ as

$$A \equiv (1 - \gamma_0)/\gamma_0. \quad (8)$$

In (7) C_e' is the capacity of the emitter-base junction, and r_e' is the low-frequency short-circuit input impedance to be discussed below ($r_e' \doteq kT/q_e I_e$ as given by Shockley et al.^{2a}). Finally, the hyperbolic-tangent function is an approximation for a more complicated expression just as β was approximated above.

For the moment, it may be assumed that the effect of $\omega C_e' r_e'$ is negligible, but that $A \neq 0$, i.e., $\gamma_0 \neq 1$. As the frequency is increased, the hyperbolic function remains substantially constant, but the diffusion-admittance term $(1 + j\omega\tau_e)^{1/2}$ discussed by Shockley⁸ increases, causing a decrease in $|\gamma|$. If ω_c were infinitely high (τ_D infinitely small), ultimately $|\gamma|$ would decrease as $\omega^{-1/2}$, and the phase angle of γ would approach -45

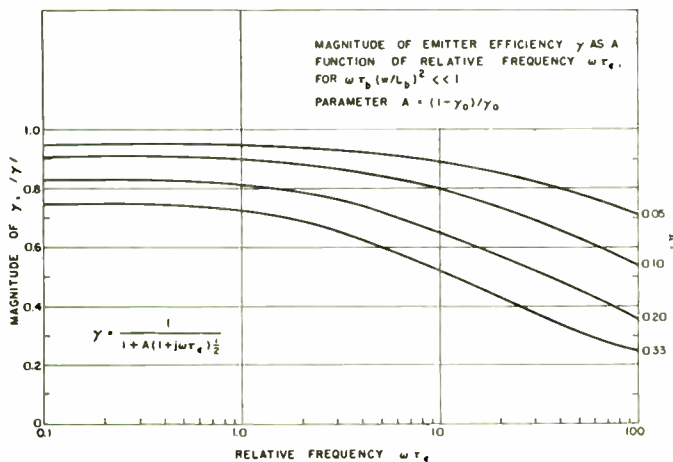

Fig. 3—Theoretical variation of the magnitude of the emitter efficiency γ with relative frequency, for case of $\omega\tau_D \ll 1$.

degrees. This is shown by the curves of Fig. 3 for several values of A . However, with finite ω_c , the hyperbolic-function term within the brackets in (7) decreases in magnitude and becomes complex with increasing frequency. This tends to counteract the increase in magnitude of the term $(1 + j\omega\tau_e)^{1/2}$, and $|\gamma|$ decreases less rapidly than $\omega^{-1/2}$. Ultimately, the hyperbolic-function term decreases with frequency at the same rate as $(1 + j\omega\tau_e)^{1/2}$ increases, so that the product becomes constant. Hence, $|\gamma|$ attains a limiting high-frequency value that is determined by the ratio τ_e/τ_D and by the parameter A . (Actually, the limiting value is determined only by the ratio of minority-carrier concentrations in emitter and base respectively and by the ratio of their mobilities, which is a constant.) This is shown by the curves of Fig. 4 for several ratios of τ_D/τ_e for a

particular value of A corresponding to $\gamma_0 = 0.93$. Note that the high-frequency value of $|\gamma|$ may be higher or lower than γ_0 in general.

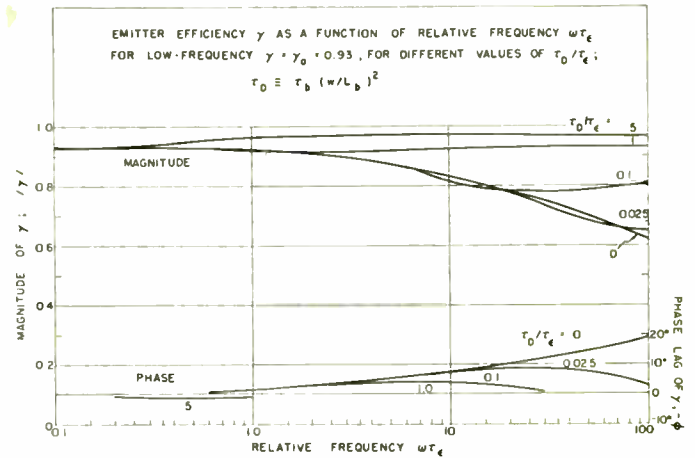

Fig. 4—Theoretical variation of emitter efficiency γ with relative frequency, for $\gamma_0 = 0.93$.

The effect of both γ and β in determining the overall frequency behavior of α is illustrated by the curves of Fig. 5 for a particular case. Numerical values of the parameters were selected to provide a fit with experimental results of α versus frequency obtained for an experimental grown-junction transistor.⁹ Note that γ alone determines the low-frequency behavior of $|\alpha'|$, resulting in a gradual fall-off of $|\alpha'|$, whereas the effect of β becomes significant at higher frequencies. This “slow-drool” type of behavior of $|\alpha'|$ at low frequencies appears to be typical of the effect of γ upon α' .

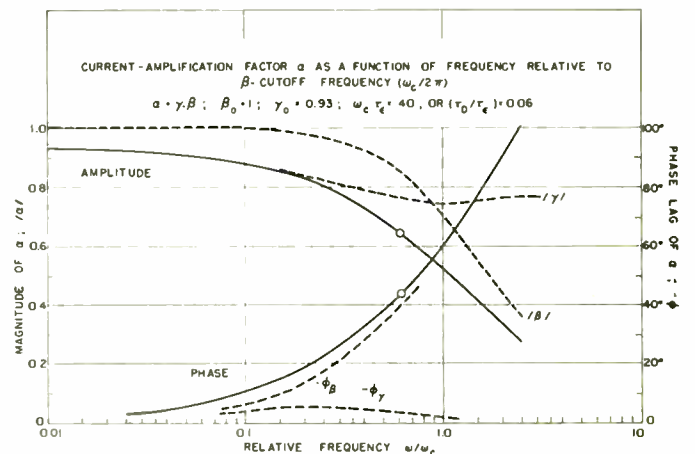

Fig. 5—Theoretical variation of current-amplification factor α with relative frequency for $\gamma_0 = 0.93$, for ratio of diffusion time τ_D to emitter lifetime τ_e of 0.06.

Note also that the cut-off frequency of α' , indicated by the circles, has been reduced relative to the β -cut-off frequency $\omega_c/2\pi$. Furthermore, the magnitude of the phase angle at α' -cut-off frequency is substantially less than the 57 degrees which occurs for β -type cut-off only.

⁸ W. Shockley, “The theory of p - n junctions in semiconductors and p - n junction transistors,” *Bell Sys. Tech. Jour.*, vol. 28, pp. 459-465; July, 1949. Also “Electrons and Holes in Semiconductors,” pp. 313-318; D. Van Nostrand, New York, N. Y., 1950.

⁹ This transistor was fabricated by R. N. Hall in the course of his experimental work with crystal growing. The β -cut-off frequency $\omega_c/2\pi$ was of the order of 600 kc.

Suppose now that $A = 0$, i.e., $\gamma_0 = 1$, in order to consider the relatively simple effect of C_e' . The capacity of the emitter-base junction may be fairly large because of the small-voltage drop across this junction (of the order of a few tenths of a volt); hence, C_e' could be of the order of $50 \mu\mu\text{f}$ for a junction for which reverse-bias capacitance was of the order of $10 \mu\mu\text{f}$. Therefore, for low values of emitter current for which r_e' may be fairly high (of the order of 10^3 ohms for $I_e = 25 \mu\text{a}$) the product $\omega C_e' r_e'$ may be appreciable at operating frequencies. In this case, the reactive ac current through the emitter-base junction causes an increase in emitter current at increasing frequency without producing a corresponding increase in collector current; hence γ will decrease in magnitude, ultimately as $1/\omega$. However, at frequencies approaching the β -cut-off frequency $\omega_c/2\pi$, the forward-bias impedance of the emitter-base junction decreases as the square root of increasing frequency. This tends to reduce the bypassing effect of C_e' in a manner decreased mathematically by a hyperbolic-tangent term in (7). Hence, at the higher frequencies $|\gamma|$ will decrease less rapidly. A typical calculated variation of γ with frequency due to the effect of C_e' is shown in Fig. 6 for several values of $\omega_c C_e' r_e'$. For the (relatively large) value of $\omega_c C_e' r_e' = 1$, the decreased rate of fall-off of $|\gamma|$ with frequency that occurs at the higher frequencies is quite evident.

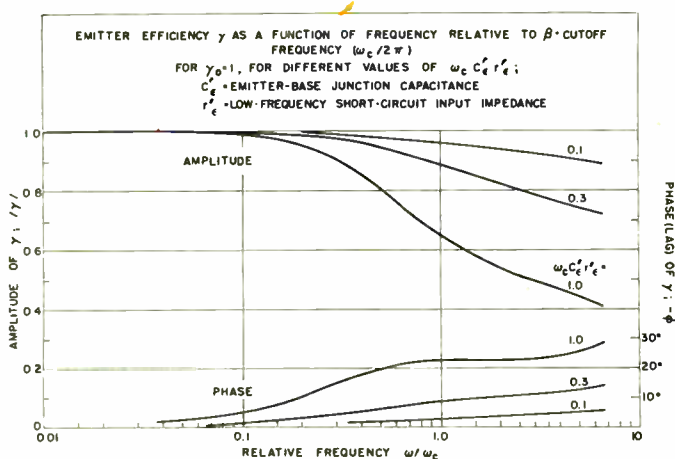

Fig. 6—Theoretical variation of emitter efficiency γ with relative frequency illustrating effect of emitter junction capacitance, with $\gamma_0 = 1.0$.

2. Modification due to r_b' :

$$-h_{21} = \alpha = (\alpha' + r_b' h_{22}') / (1 + r_b' h_{22}'). \quad (9)$$

At high frequencies, the open-circuit output admittance h_{22}' of the theoretical transistor is essentially capacitive reactive and hence increases in magnitude with increasing frequency. If the product $r_b' h_{22}'$ is appreciable (of the order of 0.1 or more) at the β -cut-off frequency $\omega_c/2\pi$, the frequency variation of α for the over-all transistor may be significantly different from that of the theoretical model. In particular, $r_b' h_{22}'$ has a positive reactive component which subtracts from the

negative reactive component of α' to reduce the magnitude of α relative to that of α' . Furthermore, the rate of change of $|\alpha|$ with frequency generally is increased.¹⁰

A typical variation of α with frequency of this type is shown in Fig. 7 for a particular case, in which it is assumed that $\gamma = 1$, and that $h_{22}' = j\omega C_{22}'$ only, i.e., output conductance is neglected. The base resistance r_b' is assumed to be such that at the β -cut-off frequency

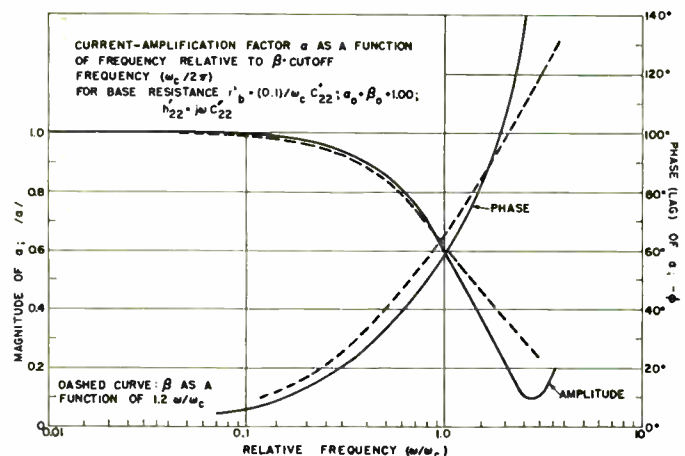

Fig. 7—Theoretical variation of current-amplification factor α with relative frequency illustrating effect of base spreading resistance, for $\alpha_0 = \beta_0 = 1.0$, for negligible collector-base conductance.

$\omega_c r_b' C_{22}' = 0.1$ (e.g., $\omega_c/2\pi = 5 \times 10^6$, $r_b' = 400$, $C_{22}' = 8 \mu\mu\text{f}$). In order to show the rate of decrease of $|\alpha|$ relative to that of $|\beta|$, the dashed curve of β in Fig. 7 has been plotted to a slightly different abscissa scale. Note that the cut-off frequency of α is reduced approximately 20 per cent relative to that of $\alpha' = \beta$ because of r_b' , and that the rate of cut-off of $|\alpha|$ is more rapid than the cut-off of β . Such more-rapid-than-theoretical decreases in α with frequency have been observed in practice with transistors having relatively large values of base spreading resistance.¹¹

B. Open-Circuit Collector-Base Admittance h_{22}

1. Theoretical model: The exact expression for h_{22} which is given in section II is quite complicated for

¹⁰ From a circuit point of view, this behavior may be explained as follows. Total impressed voltage in the collector-base mesh is the sum of an $i_e r_b'$ drop in the base resistance plus the voltage appearing across the collector capacitance due to injected emitter current (cf. the current generator of the equivalent circuit in Fig. 1). For a constant ac emitter current, the first term is constant with frequency, whereas, the voltage across the capacitance decreases with increasing frequency because of the decrease in the magnitude of both α and of the capacitive reactance. Of considerably more importance, however, is the fact that the voltage across the collector capacitance lags the $i_e r_b'$ drop by more than 90 degrees because of the phase lag of α . Hence, these two impressed voltages tend to cancel each other, and the voltage available in the collector-base mesh decreases, causing α to fall off with frequency faster than if r_b' were zero. At very high frequencies $i_e r_b'$ voltage predominates, and α actually increases toward unity (but there is essentially no power gain at these frequencies).

¹¹ Note, for example, the sharper α -cut-off of the junction transistor tetrode when operated as a triode with high base resistance relative to the tetrode operation in which base resistance is reduced. See R. L. Wallace, Jr., L. G. Schimpf, and E. Dickten, "A junction transistor tetrode for high frequency use," PROC. I.R.E., vol. 40, Fig. 7, p. 1397; November, 1952. However, this effect of r_b' on α described above should not be confused with the effect of r_b' on power gain described by Wallace, et al.

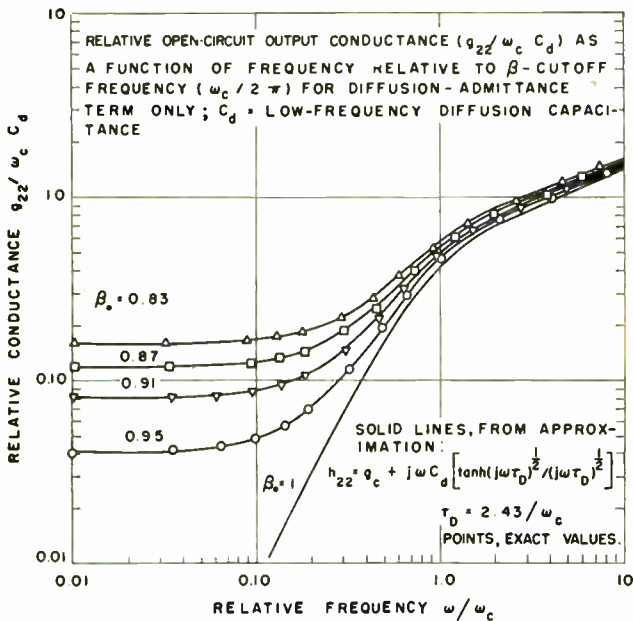

Fig. 8—Theoretical variation of relative open-circuit output conductance with relative frequency, for diffusion-admittance term only.

purposes of calculation. The result may be simplified somewhat by expanding the hyperbolic-tangent in a Taylor Series and retaining only the first few terms, in order to make use of the function of the semi-imaginary argument $(j\omega\tau_D)^{1/2}$ as was done in the case of the current-amplification factor β . The result may be written in the form

$$h_{22}' \doteq j\omega C_c' + g_{c\beta} + j\omega C_d \left[\tanh(j\omega\tau_D)^{1/2} / (j\omega\tau_D)^{1/2} \right] + g_{c\gamma}(\gamma/\gamma_0) \cdot \beta^2 \cdot (1 + j\omega\tau_c)^{1/2}, \quad (10)$$

where C_c' is the capacity of the collector-base junction, $g_{c\beta}$ and $g_{c\gamma}$ are two parts of the expression for collector conductance calculated by Early due to the effect of space-charge-layer widening, and C_d is a diffusion capacity due to charge stored in the base layer by the dc emitter current. (See Appendix B for more details of C_d .) In particular¹²

$$g_{c\beta} \doteq 2\alpha_0(I_e/w_0)(\partial w/\partial E_c)(1 - \beta_0) \\ g_{c\gamma} \doteq \alpha_0(I_e/w_0)(\partial w/\partial E_c)(1 - \gamma_0). \quad (11)$$

where I_e is the dc emitter current, w_0 is the thickness of the base region of the transistor, and $(\partial w/\partial E_c)$ is rate of change of base thickness with dc collector voltage.

In (10), the first and fourth terms are substantially exact, whereas the second and third terms result from the approximation mentioned above.¹³ However, numerical values of these terms have been calculated and have been compared with values calculated from the

¹² See Early (footnote 4), p. 1403; the expressions given here for g_c are approximately correct for $\alpha > 0.95$. For $\alpha < 0.95$, the more exact results given by Early (p. 1405) should be used.

¹³ More accurately, the term $g_{c\beta}$ should read $(g_{c\beta}/2) \{ [\tanh(j\omega\tau_D)^{1/2} / (j\omega\tau_D)^{1/2}] + \beta/\beta_0 \}$. However, the frequency variation of this term generally is relatively unimportant compared to that of the C_d term above, and (10) as given is sufficiently accurate for most practical purposes.

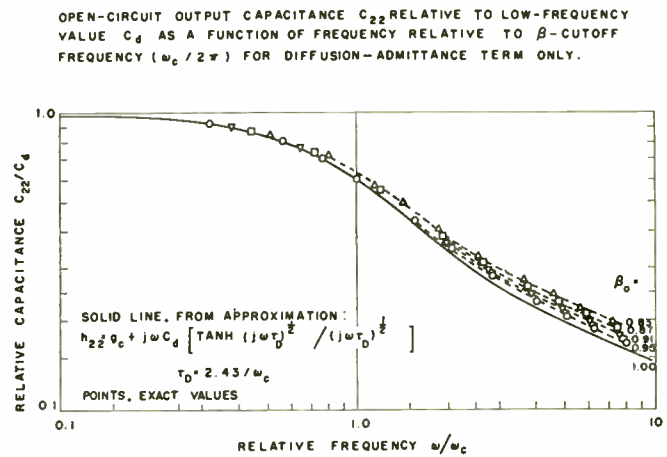

Fig. 9—Theoretical variation of relative open-circuit output capacitance with relative frequency, for diffusion admittance term only.

corresponding exact expression. Results of the comparison of real and imaginary parts of $(h_{22}' - j\omega C_c')$ are shown in normalized form in Figs. 8 and 9 respectively for values of $\beta_0 = 0.95, 0.91, 0.87, 0.83$. (Fig. 9 actually shows $1/j\omega$ times the imaginary part, i.e., the effective capacity.) For the smaller values of β_0 the approximate values may be in error by ten to fifteen per cent, whereas the error is less for the larger values of β_0 .

When γ is essentially unity, as in the case of fused-junction transistors,¹⁴ the fourth term of (10) vanishes, and h_{22}' reduces to the form described earlier.¹⁵ In this case, the diffusion capacitance C_d may be determined from the difference between the value of the low-frequency collector-base capacitance corresponding to a given emitter current and that for zero-emitter current. For an abrupt, or step, junction, as in fused-junction transistors, theory given in Appendix B indicates that C_d is directly proportional to dc emitter current and inversely proportional to square root of collector voltage. Experimental values of collector-base capacitance as a function of dc operating bias, which are shown in Fig. 10, are in reasonably good agreement with these theoretical results. Note, however, the departure of linearity with respect to I_e at the larger currents. In this case, the applied current is sufficiently great that the number of injected (minority) carriers is comparable with the number of (majority) carriers normally present in the base. Thus, the condition of low-level carrier injection implicitly assumed in the theoretical analysis is violated, and the theoretical results can no longer be expected to agree perfectly with experiment.

As the frequency is increased, the term involving C_d becomes complex, and a conductance term results from this diffusion capacitance. This conductance term increases as the square of the frequency at first; hence, the conductance g_c normally predominates at low frequencies. At higher frequencies, the conductance due

¹⁴ E. L. Steele, "Theory of alpha for $p-n-p$ diffused junction transistor," Proc. I.R.E., vol. 40, p. 1427; November, 1952.

¹⁵ R. L. Pritchard, "Collector-Base Impedance of a Junction Transistor," Proc. I.R.E., vol. 41, p. 1060; August, 1953.

to C_d predominates, and increases ultimately as the square root of the frequency. This is shown by the curves of Fig. 8. The curve for $\beta_0=1$ can be used with any low-frequency value of g_c to calculate g_{22} versus frequency according to the approximate equation (10).

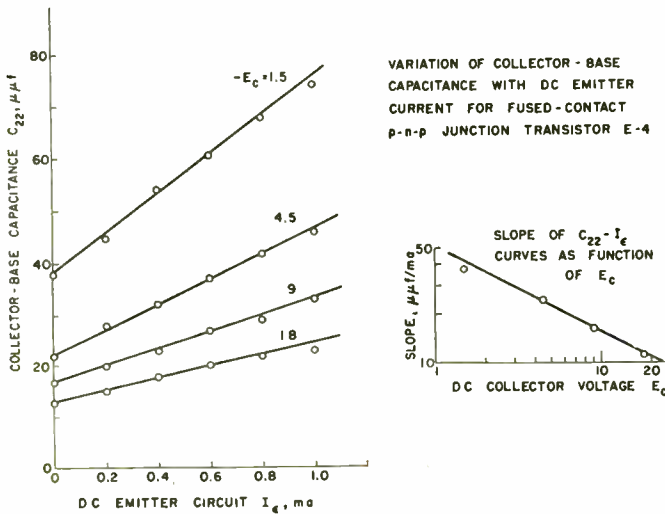

Fig. 10—Variation of collector-base capacitance with dc bias for $p-n-p$ fused-junction transistor.

On the other hand, the capacitive part of the term involving C_d decreases with increasing frequency, ultimately as the square root of the frequency, as shown in Fig. 9. Hence, the collector-base capacitance decreases from its low-frequency value of $(C_c' + C_d)$ to an ultimate high-frequency value of C_c' .

It is especially important to note the following: If C_d is small relative to C_c' , the frequency variation of C_{22} may be relatively unimportant; however, if C_d is appreciable in magnitude (e.g., several $\mu\mu f$), the high-frequency collector-base conductance of the transistor may be quite large, causing an over-all decrease in the effective Q of the device.

Experimental results for the frequency variation of h_{22} are shown in Fig. 11 for an early model fused-junction $p-n-p$ transistor developed by Saby.⁵ The solid curves have been calculated from the approximate equation (10) using as data only the low-frequency values of C_c , $C_d \equiv C_{22} - C_c$, g_{22} , and the α -cut-off frequency f_c . Agreement between experimental and theoretical results is surprisingly good.

When $\gamma_0 \neq 1$, in addition to the admittance terms discussed above, h_{22}' contains an additional diffusion admittance term of the type $(1 + j\omega\tau)^{1/2}$ discussed by Shockley,⁸ multiplied by the frequency-sensitive factors γ and β^2 . Because of the rapid decrease of $|\beta|^2$ with increasing frequency, the effect of this extra term becomes less important at the higher frequencies.

2. Modification due to r_b' :

$$h_{22} = h_{22}' / (1 + r_b' h_{22}') \quad (12)$$

When $r_b' h_{22}'$ is appreciable, h_{22} becomes slightly different from h_{22}' as described above. The principal effect

of r_b' on h_{22} is to increase the high-frequency conductance, and to a lesser extent to reduce high-frequency capacitance. Thus, to a first approximation, if $h_{22}' \approx j\omega C_{22}'$, $h_{22} \approx (\omega^2 r_b' C_{22}'^2 + j\omega C_{22}') / [1 + (\omega r_b' C_{22}')^2]$. In some transistors, with very small values of C_d , the conductance due to r_b' may be the dominant factor in the conductive component of h_{22} at high frequencies.

C. Short-Circuit Input Impedance h_{11}'

1. Theoretical model:

$$h_{11}' \doteq r_e' (\gamma / \gamma_0) [\tanh(j\omega\tau_D)^{1/2} / (j\omega\tau_D)^{1/2}] \quad (13)$$

Alternatively h_{11}' may be represented as the parallel combination of 3 admittances:

$$1/h_{11}' \doteq (\gamma_0 / r_e') [(j\omega\tau_D)^{1/2} \coth(j\omega\tau_D)^{1/2} + \frac{1 - \gamma_0}{r_e'} (1 + j\omega\tau_e)^{1/2} + j\omega C_e'] \quad (14)$$

As before, the hyperbolic-tangent function is an approximation that is accurate to within 5–10 per cent for $\beta_0 > 0.9$. The emitter resistance r_e' is the quantity calculated by Shockley, et al.,² as $r_e' = (kT/q_e I_e)$; actually I_e should be replaced by the sum of the input emitter current plus a small emitter-saturation current (the current that flows between emitter and base when both collector and emitter are biased in the reverse direction.)

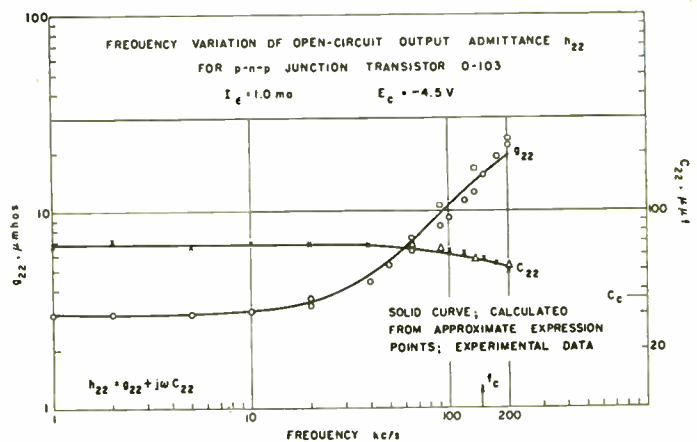

Fig. 11—Variation of open-circuit output admittance with frequency for $p-n-p$ fused-junction transistor.

Hence, r_e' has a limiting value for very small emitter currents. It should be emphasized that r_e' is not the usual emitter resistance of the equivalent Tee circuit. Early has shown that the Tee emitter resistance may be smaller than r_e' by a factor of 2 or more.

Consider first that $\gamma=1$. As the frequency is increased, the term within the brackets of (13) decreases in magnitude and has an associated phase shift. The real and imaginary parts of the reciprocal of the expression within the brackets of (13) (which is the same as the first term in brackets in (14)) are shown in Fig. 12; thus, Fig. 12 shows the relative input admittance of the

the theoretical model. Note that for frequencies up to approximately the β -cut-off frequency the (relative) conductance is essentially constant, while the susceptance behaves as that of a capacity having an approximate value of

$$C_e'' = 0.81/\omega_c r_e'. \quad (15)$$

In general, this capacity will be quite large (e.g., $r_e' = 25$ ohms, $\omega_c/2\pi = 5 \times 10^6$, $C_e'' \approx 0.001 \mu\text{f}$). At frequencies greater than the β -cut-off frequency, the real and imaginary parts of the admittance tend to become equal, and to vary directly as the square root of the frequency. Thus, the over-all frequency behavior of the first term of (14) is very similar to that of the conventional diffusion admittance³ (except for the absolute frequency scale, which is proportional in this case to diffusion time through the base rather than to lifetime).

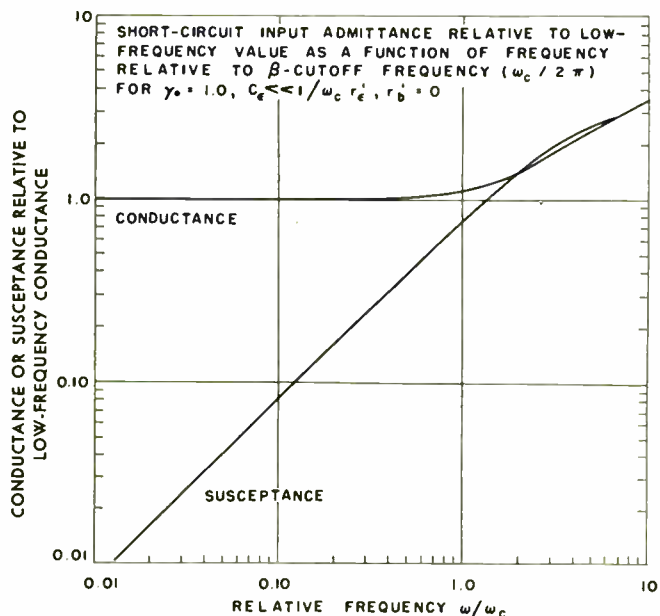

Fig. 12—Theoretical variation of relative short-circuit input admittance with relative frequency for theoretical model, for $\gamma_0 = 1$; effect of emitter-junction capacitance not included.

When $\gamma_0 \neq 1$, a conventional diffusion admittance, the magnitude of which is proportional to $(1-\gamma_0)/r_e'$, must be added in parallel with the admittance term described above. In addition, the short-circuit input admittance includes the effect of emitter-base junction capacitance C_e' . This will be important only if C_e'' is quite small, as in the case of low emitter currents.

2. Modification due to r_b' :

$$h_{11} = h_{11}' + [r_b'(1-\alpha')(1-h_{12}')/(1+r_b'h_{22}')]. \quad (16)$$

In general the term $(1-h_{12}')$ can be approximated by unity at all frequencies.

The second term in this equation will increase with frequency as the quadrature-component of α' becomes significant. This will occur at frequencies of the order

of $(1-\alpha_0)$ times the α -cut-off frequency.¹⁶ If r_b' can be considered as a real constant independent of frequency (which may not be valid for some transistors), this second term should continue to increase with frequency until the limiting value of r_b' is reached, or until $r_b'h_{22}'$ becomes appreciable. Furthermore, the reactive part of the bracketed term will be inductive for frequencies up to approximately $5\omega_c$, provided $r_b'h_{22}'$ is negligible. For values of emitter current $I_e = 1\text{ma}$, or greater, the h_{11}' term generally will be negligible at the higher frequencies. Hence, the input impedance of the over-all transistor is determined essentially by the base spreading resistance multiplied by $(1-\alpha)$ and should be inductive.¹⁷

D. Open-Circuit Voltage Feedback Parameter h_{12}

1. Theoretical model:

$$h_{12}' = \mu_{ec}(\alpha'/\alpha_0). \quad (17)$$

At low frequencies, h_{12} becomes identical with the μ_{ec} parameter introduced by Early.⁴ As the frequency is increased, h_{12}' varies with frequency in exactly the same manner as does α' . However, generally this is of no significance because of the modification introduced by r_b' .

2. Modification due to r_b' :

$$h_{12} = (h_{12}' + r_b'h_{22}')/(1 + r_b'h_{22}'). \quad (18)$$

As frequency is increased from very low values, h_{22}' becomes essentially capacitive reactive (this may occur between 500 and 50,000 cps, for example). Hence, the term $r_b'h_{22}'$ will increase linearly with frequency. The magnitude of this term generally is such that an increase in h_{12} relative to its low-frequency value of $(\mu_{ec} + g_{22}r_b')$ may be noted at frequencies of the order 5–50 kc. (e.g. with $r_b' = 400$ ohms, $C_{22} \approx 8 \mu\text{f}$, $(\mu_{ec} + g_{22}r_b') \approx 3 \times 10^{-4}$, $|h_{12}|$ would increase to $\sqrt{2}$ times its low-frequency value at a frequency of 15 kc.). Beyond this frequency range, $|h_{12}|$ increases linearly with frequency, up to frequencies for which $r_b'h_{22}'$ becomes appreciable relative to unity.

E. Equivalent Circuit

The frequency variation of the junction-transistor parameters also may be described by means of an equivalent circuit, if desired. A substantially exact circuit is shown in section 11 (Fig. 16), and an approximate circuit for the case of $\gamma = 1$, applicable for the fused junction transistor, has been given previously.¹⁵

For the more general case, an approximate circuit is shown in Fig. 13. This circuit is based on the approximations used above for the parameters h_{ij}' . Thus, dis-

¹⁶ The frequency behavior of $(1-\alpha)$ is very similar to that of the grounded-emitter current-amplification factor $\alpha/(1-\alpha)$ discussed earlier by the writer; see footnote 2b.

¹⁷ The inductive input reactance of the junction transistor at high frequencies was pointed out by Wallace et al., (footnote 11), p. 1400.

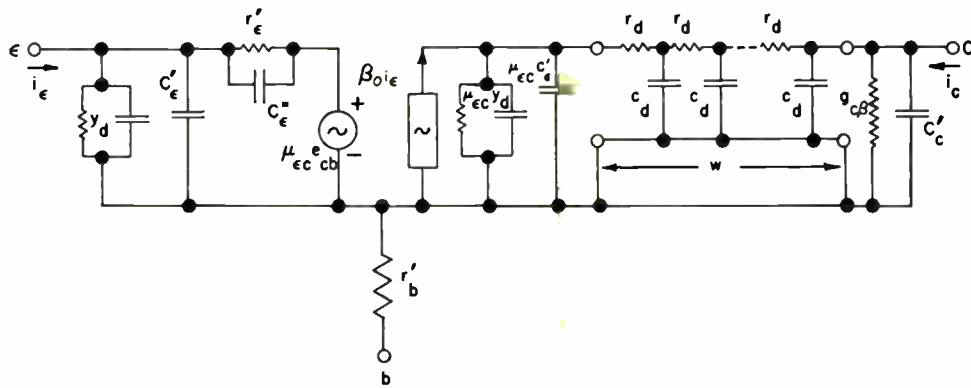

Fig. 13—Approximate equivalent circuit employing RC transmission line for junction transistor.

tributed shunt conductance in the collector-circuit transmission line has been replaced by a lumped conductance g_{cb} . Also, the transmission line in the emitter circuit, which is indicated by the form of h_{11}' , has been replaced by a lumped resistance and capacitance in parallel, in accordance with the frequency variation of h_{11}' noted above (cf. Fig. 12). Note that the effect of nonunity γ is indicated by the presence of the diffusion admittance y_d (of the conventional form $(1+j\omega\tau)^{1/2}$) and the emitter junction capacitance C'_e in the emitter circuit and at the input to the collector-circuit transmission line. When y_d and C'_e can be neglected, the circuit of Fig. 13 reduces to that given previously,¹⁵ with $z_b \equiv r'_b$ and $z_c \equiv r'_c/(1+j\omega r'_c C'_c)$.

F. Summary

In general, the frequency variation of the junction-transistor parameters cannot be described in simple terms. However, for the special and important case for which the emitter efficiency γ can be assumed to equal unity at all frequencies, some simplification is possible. This is normally the case in fused-junction transistors.

It has been shown that the current-amplification factor varies essentially as the hyperbolic-secant function described earlier. However, a more rapid fall-off with frequency can be obtained at higher frequencies if base-spreading resistance is appreciable. The open-circuit collector-base admittance can be described as the parallel combination of the collector-base junction capacity, the conductance due to space-charge-layer widening, and a frequency-sensitive (complex) diffusion capacity also due to space-charge-layer widening. At high frequencies, the principal effect of the diffusion capacitance is to increase the conductance of the collector-base admittance. Base-spreading resistance also may increase high-frequency collector-base conductance. Short-circuit input impedance consists of two impedances in series. The first of these is the parallel combination of the original Shockley, et al., emitter resistance ($kT/q_e I_e$) and a capacitance that is inversely proportional to this emitter resistance, while the second impedance is the base-spreading resistance multiplied by the factor $(1-\alpha)$. As frequency is increased, the latter

term increases in magnitude and becomes inductive reactive, due to the increase of the quadrature component of α . Finally, the voltage-feedback parameter is the sum of two terms. The first of these is essentially frequency independent and describes the voltage feedback calculated by Early plus current feedback through the effective collector conductance and base-spreading resistance. On the other hand, the second term, which describes the current feedback through the effective collector capacitance and base-spreading resistance, is proportional to frequency and dominates at frequencies greater than a few tens of kilocycles.

II. DERIVATION OF VOLTAGE-CURRENT RELATIONS FOR A THEORETICAL JUNCTION TRANSISTOR

A theoretical analysis for the voltage-current relations of a one-dimensional transistor was given originally by W. Shockley.⁸ Subsequently, J. M. Early⁴ extended this analysis to include the effect of space-charge-layer widening. The analysis to be described below is an extension of this work to include the effect of frequency variations. Accordingly, the basic features and assumptions of the original analysis will not be reviewed here.

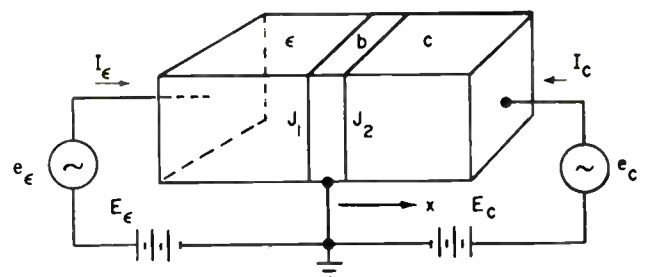

Fig. 14—Theoretical model of one-dimensional junction transistor.

A. Formulation

Consider the theoretical model of the junction transistor shown in Fig. 14. A $p-n-p$ structure will be assumed for convenience; however, the final results also can be used for the $n-p-n$ transistor by making only slight changes in notation, as will be indicated below.

The minority-carrier (hole) density p in the base region must satisfy the equation

$$\frac{\partial p}{\partial t} = \frac{p_B - p}{\tau_B} + D_p \frac{\partial^2 p}{\partial x^2}, \quad (19)$$

where p_B is the equilibrium minority-carrier concentration in the base region, τ_B is the lifetime of the minority carriers in the base, and D_p is the diffusion constant for holes.

A solution for p may be assumed in the form of a Fourier series in time; thus:

$$p(x, t) = p_B + \sum_{m=-\infty}^{\infty} p_m(x) \cdot e^{jm\omega t}. \quad (20)$$

Substitution of (20) in (19) yields an infinite set of equations of the form

$$\frac{\partial^2 p_m}{\partial x^2} - \Gamma_m^2 p_m = 0, \quad (21)$$

where

$$\Gamma_m \equiv (1/L_B)(1 + jm\omega\tau_B)^{1/2} \quad (22)$$

is a "propagation constant" associated with the frequency $m\omega$. Here L_B is the diffusion length for minority carriers in the base and is defined as

$$L_B \equiv (D_p\tau_B)^{1/2}. \quad (23)$$

Note that at low frequencies $\Gamma_m \approx \Gamma_0 = 1/L_B$ whereas at higher frequencies, Γ_m increases as the square root of the frequency. A solution for well-known equation (21) is

$$p_m(x) = A_m \cosh \Gamma_m x + B_m \sinh \Gamma_m x, \quad (24)$$

where A_m and B_m are constants to be determined by the boundary conditions.

1. *Boundary Conditions:* The boundary conditions to be satisfied by $p(x, t)$ are as follows:

$$\left. \begin{aligned} \text{at } J_1, p(x, t) &= p_B e^{a(E_e + e_e)} \\ \text{at } J_2, p(x, t) &= p_B e^{a(E_c + e_c)} \end{aligned} \right\} \quad (25)$$

where

$$a \equiv (q_e/kT), \quad (26)$$

and E_e, e_e, E_c, e_c , are the dc and ac emitter and collector voltages, respectively. It is assumed that each of the ac voltages may be expressed as a Fourier series in time, with a fundamental frequency ω . By choosing a suitable origin for the x -co-ordinate system and by imposing (25) on (20) and (24), solutions for A_m and B_m could be obtained in a straightforward manner. However, in general, the exact locations of junctions J_1 and J_2 will depend upon the thickness of the space-charge layer at each junction. Since the thickness is a function of the voltage across the junction, the exact locations of J_1 and J_2 will be instantaneous functions of time. Accordingly, in the (much-distorted) co-ordinate system shown in Fig. 15, the instantaneous location of junction

J_1 is defined as $\delta \equiv -\delta_1$, where

$$\delta_1 = \left(\frac{\partial \delta}{\partial E_e} \right) e_e + \frac{1}{2!} \left(\frac{\partial^2 \delta}{\partial E_e^2} \right) e_e^2 + \dots, \quad (27)$$

and the relation between δ and E_e depends upon the nature of the emitter-base junction.⁴ Similarly, the location of J_2 is defined as

$$w \equiv w_0 + w_1 \quad (28)$$

where

$$w_1 = \left(\frac{\partial w}{\partial E_c} \right) e_c + \frac{1}{2!} \left(\frac{\partial^2 w}{\partial E_c^2} \right) e_c^2 + \dots, \quad (29)$$

and the relation between w and E_c depends upon the nature of the collector-base junction.

2. *Linearity.* In order to obtain the desired linear, small-signal ac operation of the transistor for the general case it will be assumed that the magnitudes of e_e and e_c are small relative to the thermal voltage $1/a = kT/q_e$. Hence, (25) may be written as

$$\text{at } J_1: p(\delta, t) \doteq p_B e^{aE_e} [1 + ae_e], \quad (30a)$$

$$\text{at } J_2: p(w, t) \doteq p_B e^{aE_c} [1 + ae_c], \quad (30b)$$

$$|ae| \ll 2.$$

Furthermore, it will be assumed that $|e_e|$ and $|e_c|$ are small relative to $|E_e|$ and $|E_c|$ respectively. In particular, if $|e| \ll 2|E|$, the relations between w_1 and e_c and between δ_1 and e_e may be taken to be linear, i.e.,

$$w_1 \doteq (\partial w / \partial E_c) e_c; \delta_1 \doteq (\partial \delta / \partial E_e) e_e, \quad |e| \ll 2|E|. \quad (31)$$

Fig. 15—Co-ordinate system for theoretical model of a junction transistor.

For normal transistor operation with the emitter-base junction biased in the forward direction, the approximation (30) is more restrictive than (31) for e_e , since the terms involving δ_1 become insignificant compared to those involving ae_e . On the other hand, with the collector-base junction biased in the reverse direction, the approximation (30) is not necessary for e_c , since the terms involving $(ae^{aE_c})e_c$ are insignificant compared to those involving w_1 . In other words, to obtain results for normal transistor operation, the effect of space-charge-layer widening at the emitter-base junction may be neglected, whereas the classical reverse-bias admittance of the collector-base junction may be neglected, as was done by Early.

Returning to the more general case, additional assumptions that will be made to insure linearity are as follows:

- a) Magnitude of ac junction displacements δ_1 and w_1 small relative to diffusion length L_B , i.e., $|w_1|, |\delta_1| \ll L_B$.
- b) Also, $|\Gamma_1 w_1| \ll 1, |\Gamma_1 \delta_1| \ll 1$, is assumed at all frequencies of interest. This requires that the diffusion time across the distance $|\delta_1|$ or $|w_1|$ be small relative to periods of all frequencies of interest. Both a) and b) above are easily satisfied in general.

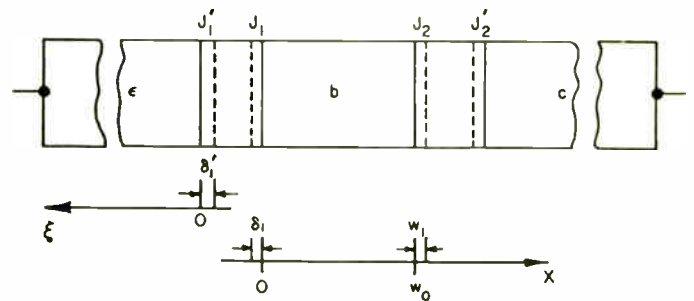
B. Solution for Minority-Carrier Current

By imposing the requirements for small-signal linear operation upon the more general results given above in (20) through (29), (approximate) first-order solutions may be obtained for the dc and fundamental ac ($m=0, 1$, respectively) minority-carrier concentrations as follows. Equation (24) may be substituted in (20) with only $m=0, 1$ terms retained. Imposing (30a, b) upon the result evaluated once at $x = -\delta_1$ and once at $x = w_0 + w_1$ respectively, with δ_1 and w_1 defined by (31), yields two equations involving the four constants A_0, B_0, A_1, B_1 . (In applying both (30) and (31), e_e and e_c should be replaced by $e_e e^{j\omega t}$ and $e_c e^{j\omega t}$ respectively.) Since dc and ac solutions must hold simultaneously, these two equations actually yield four simultaneous equations from which A_0, B_0, A_1 and B_1 may be determined. Note, however, that *before* splitting the equations into dc and ac parts, it is necessary to expand *each* of the hyperbolic functions into dc and ac terms, which arise from the "moving" boundary conditions, e.g.,

$$\begin{aligned} \sinh \Gamma w &= \sinh \Gamma(w_0 + w_1) \\ &= \sinh \Gamma w_0 \cosh \Gamma w_1 + \cosh \Gamma w_0 \sinh \Gamma w_1. \end{aligned}$$

By imposing assumptions (a) and (b) above, $\cosh \Gamma w_1$ may be replaced by unity and $\sinh \Gamma w_1$ may be replaced by Γw_1 . Finally, second-order terms of the form $A_1 \delta_1, B_1 w_1$ (which are proportional to e_e^2 or $e_c e_e$, for example) may be neglected.

Under these conditions, the above-mentioned simultaneous equations may be solved as follows:

$$\left. \begin{aligned} A_0 &= p_B (\epsilon^{aE_e} - 1) \\ B_0 &= p_B [(\epsilon^{aE_c} - 1) \operatorname{csch} \Gamma_0 w_0 - (\epsilon^{aE_e} - 1) \coth \Gamma_0 w_0] \end{aligned} \right\} \quad (32)$$

$$\left. \begin{aligned} A_1 &= [(a p_B \epsilon^{aE_e}) + B_0 \Gamma_0 (\partial \delta / \partial E_e)] e_e \\ B_1 &= \left\{ [(a p_B \epsilon^{aE_c}) - \Gamma_0 (\partial w / \partial E_c)] \cdot (A_0 \sinh \Gamma_0 w_0 \right. \\ &\quad \left. + B_0 \cosh \Gamma_0 w_0) \right\} [\operatorname{csch} \Gamma_1 w_0] e_c - A_1 \coth \Gamma_1 w_0 \end{aligned} \right\} \quad (33)$$

By substituting these values in (24) for $m=0, 1$, the dc and first-harmonic ac solutions respectively for $p(x, t)$ may be obtained if desired.

The minority-carrier (hole) current $I_p(x) \equiv I_{p0}(x) + i_{p1}(x)$ in the base may be obtained from $p(x, t)$ from the relation

$$I_p(x) = -Sq_e D_p (\partial p / \partial x) \quad (34)$$

where S is the cross-section area of the transistor. The

hole current into the base from the emitter is obtained from this relation evaluated at $x = \delta$, while $I_p(w)$ represents the hole current into the collector from the base. After some algebraic manipulation, it follows that:

$$\left. \begin{aligned} I_{p0}(\delta) &= -Sq_e D_p \Gamma_0 B_0 \\ i_{p1}(\delta) &= -Sq_e D_p [\Gamma_1 B_1 - \Gamma_0^2 A_0 (\partial \delta / \partial E_e) e_e] \end{aligned} \right\} \quad (35)$$

$$\left. \begin{aligned} I_{p0}(w) &= -Sq_e D_p \Gamma_0 [A_0 \sinh \Gamma_0 w_0 + B_0 \cosh \Gamma_0 w_0] \\ i_{p1}(w) &= -Sq_e D_p \left\{ \Gamma_1 [A_1 \sinh \Gamma_1 w_0 + B_1 \cosh \Gamma_1 w_0] \right. \\ &\quad \left. + \Gamma_0^2 (\partial w / \partial E_c) (e_c) [A_0 \cosh \Gamma_0 w_0 \right. \\ &\quad \left. + B_0 \sinh \Gamma_0 w_0] \right\} \end{aligned} \right\} \quad (36)$$

Explicitly, $i_{p1}(\delta)$ may be written as

$$\begin{aligned} i_{p1}(\delta) &= +Sq_e D_p p_B \left\{ (a \epsilon^{aE_e}) (\Gamma_1 \coth \Gamma_1 w_0) - \left(\frac{\partial \delta}{\partial E_e} \right) \right. \\ &\quad \times \Gamma_0 (\Gamma_1 \coth \Gamma_1 w_0) [(\epsilon^{aE_e} - 1) \coth \Gamma_0 w_0 - (\epsilon^{aE_c} - 1) \\ &\quad \times \operatorname{csch} \Gamma_0 w_0] + \left(\frac{\partial \delta}{\partial E_e} \right) \Gamma_0^2 (\epsilon^{aE_e} - 1) \left. \right\} e_e - Sq_e D_p p_B \\ &\quad \times \left\{ (\Gamma_1 \operatorname{csch} \Gamma_1 w_0) (a \epsilon^{aE_e}) \right. \\ &\quad \left. + \left(\frac{\partial w}{\partial E_c} \right) \Gamma_0 (\Gamma_1 \operatorname{csch} \Gamma_1 w_0) [(\epsilon^{aE_e} - 1) \right. \\ &\quad \left. \times \operatorname{csch} \Gamma_0 w_0 - (\epsilon^{aE_c} - 1) \coth \Gamma_0 w_0] \right\} e_c. \end{aligned} \quad (37)$$

The expression for $i_{p1}(w)$ is similar to that for $i_{p1}(\delta)$ and in fact may be obtained from the latter by interchanging E_e and E_c, e_e and e_c, δ and $-w$ and by replacing w_0 by $-w_0$.

1. *Minority-Carrier Density in Emitter and Collector Regions:* In addition to the hole current in the base region, there are minority-carrier (electron) currents in the emitter and collector regions which must be included in calculating the total emitter and collector currents, respectively. Referring to the ξ -co-ordinate system of Fig. 15, the electron current $I_n(\xi)$ may be determined from the electron density $n(\xi)$ in the emitter from a relation similar to (34):

$$I_n(\xi) = +Sq_e D_n (\partial n / \partial \xi). \quad (38)$$

The electron density $n(\xi)$ must satisfy a diffusion equation of the same form as (19) for $p(x)$, and a general solution of the type assumed for $p(x)$ in (20) and (24) may be obtained for $n(\xi)$.

One of the boundary conditions which is applied to $n(\xi)$ is quite similar to that applied to $p(x)$ at J_1 , viz., that at the emitter-base junction $J_1', (\xi = \delta' \equiv -\delta_1')$,

$$\text{at } J_1', n(\xi, t) = n_e e^{a(E_e + e_e)},$$

where n_e is the equilibrium concentration of electrons in the emitter region. On the other hand, the second boundary condition applied to $n(\xi)$ is that at the contact

end of the emitter region $\xi \equiv d_e$, $n(\xi, t) = n_e$, i.e., the excess concentration shall be zero. By applying these boundary equations, by employing the same assumptions as in the case of $p(x)$, and by substituting the resulting expression for $n(\xi)$ in (38), the electron current $I_n(\delta') = I_{n0}(\delta') + i_{n1}(\delta')$ across J_1' (in the direction of positive ξ) may be calculated as:

$$\left. \begin{aligned} I_{n0}(\delta') &= -Sq_e D_n \Gamma_{e0} n_e (\epsilon^{aE_e} - 1) \coth \Gamma_{e0} d_e \\ i_{n1}(\delta') &= -Sq_e D_n n_e \left\{ (a\epsilon^{aE_e}) \Gamma_{e1} \coth \Gamma_{e1} d_e \right. \\ &\quad \left. - \Gamma_{e0} (\epsilon^{aE_e} - 1) (\partial\delta'/\partial E_e) [\Gamma_{e1} (\coth \Gamma_{e1} d_e) \right. \\ &\quad \left. \times (\coth \Gamma_{e0} d_e) - \Gamma_{e0} \right\} e_e \end{aligned} \right\} \quad (39)$$

where

$$\Gamma_{em} \equiv (1/L_e)(1 + jm\omega\tau_e)^{1/2}, \quad m = 0, 1, \quad (40)$$

while L_e and τ_e are the diffusion distance and lifetime, respectively, for electrons in the emitter.

An exactly similar set of results may be obtained for the electron current $I_n(w')$ into the collector region by replacing Γ_e , n_e , E_e , e_e , d_e and δ' with the corresponding quantities for the collector region.

It should be noted in either case that if d is greater than approximately 3 or 4 diffusion lengths, i.e., $\Gamma_0 d \geq 3$, $\coth \Gamma d$ may be replaced by unity with an error of less than one per cent. This is equivalent to describing $n(\xi)$ by a single exponential $\epsilon^{-\xi/L_e}$, as in Shockley's⁸ analysis, rather than using hyperbolic functions for $n(\xi)$.

Total dc and ac emitter currents I_e and i_e respectively (positive direction into the emitter as in Fig. 14) may be obtained by adding the hole current $I_p(\delta)$ across J_1 and the electron current $-I_n(\delta')$, given by (35) and (39) respectively. Furthermore, the reactive current due to the barrier capacitance C_e of the emitter-base junction must be included. Thus:

$$\left. \begin{aligned} I_e &= I_{p0}(\delta) - I_{n0}(\delta') \\ i_e &= i_{p1}(\delta) - i_{n1}(\delta') + j\omega C_e e_e \end{aligned} \right\} \quad (41)$$

Similar equations may be written for the dc and ac collector currents. With positive direction of collector current taken into the collector, these become:

$$\left. \begin{aligned} I_c &= -I_{p0}(w) - I_{n0}(w') \\ i_c &= -i_{p1}(w) - i_{n1}(w') + j\omega C_c e_c \end{aligned} \right\} \quad (42)$$

where C_c is the barrier capacitance of the collector-base junction.

C. Normal Transistor Operation

The general results obtained above now will be restricted to the case of normal transistor operation. In this case the emitter-base junction is biased in the forward direction, and the collector-base junction is biased in the reverse direction such that $|E_c| \ll 1/a$, i.e., with a magnitude of dc collector voltage greater than, say, 0.5 volt. Under these conditions, ϵ^{aE_c} may be neglected relative to unity; furthermore, terms involving

$a\epsilon^{aE_c}$ may be neglected relative to those involving $(\partial w/\partial E_c)$. It also can be shown¹⁸ that the terms involving $(\partial\delta/\partial E_e)$ may be neglected relative to those involving $a\epsilon^{aE_e}$.

Under these conditions, and with the additional assumption that emitter and collector regions are sufficiently wide that $\coth \Gamma d \approx 1$, (35), (36) and (32) may be combined, and the results may be substituted in (41) and (42), together with (39) plus similar equations for $I_n(w')$ to yield for the dc equations:

$$\left. \begin{aligned} I_e &= I_0(E_e) [\coth \Gamma_0 w_0 + K_{e0}] - I_0(E_c) [\operatorname{csch} \Gamma_0 w_0] \\ I_c &= -I_0(E_e) [\operatorname{csch} \Gamma_0 w_0] + I_0(E_c) [\coth \Gamma_0 w_0 + K_{c0}] \end{aligned} \right\} \quad (43)$$

where

$$\left. \begin{aligned} I_0(E) &\equiv I_0 [\epsilon^{aE} - 1] \\ I_0 &\equiv (Sq_e D_p p_B \Gamma_0) \end{aligned} \right\} \quad (44)$$

$$K_{e0} \equiv \left(\frac{D_n n_e \Gamma_{e0}}{D_p p_B \Gamma_0} \right) \quad (45)$$

and

$$K_{c0} \equiv \left(\frac{D_n n_c \Gamma_{c0}}{D_p p_B \Gamma_0} \right). \quad (46)$$

Except for the difference in notation, these are identical with the equations given by Shockley.¹⁹ By a similar combination, the ac equations may be written as

$$\left. \begin{aligned} i_e &= \left\{ F_1(E_e) \cdot (\Gamma_1/\Gamma_0) [\coth \Gamma_1 w_0 + K_{e1}] + j\omega C_e \right\} e_e \\ &\quad - F_2(E_e) \cdot (\Gamma_1/\Gamma_0) [\operatorname{csch} \Gamma_1 w_0] e_c, \\ i_c &= -F_1(E_e) \cdot (\Gamma_1/\Gamma_0) [\operatorname{csch} \Gamma_1 w_0] e_e + \left\{ F_2(E_e) \right. \\ &\quad \left. \times (\Gamma_1/\Gamma_0) [\coth \Gamma_1 w_0] - F_3 + F_4 [(\Gamma_{c1}/\Gamma_{c0}) - 1] \right\} \\ &\quad + j\omega C_c \left\} e_c, \end{aligned} \right\} \quad (47)$$

where

$$F_1(E_e) \equiv (Sq_e D_p \Gamma_0 p_B a \epsilon^{aE_e}), \quad (48)$$

$$F_2(E_e) \equiv Sq_e D_p \Gamma_0^2 p_B [(\epsilon^{aE_e} - 1) \operatorname{csch} \Gamma_0 w_0 + \coth \Gamma_0 w_0] \left(\frac{\partial w}{\partial E_e} \right), \quad (49)$$

$$F_3(E_e) \equiv Sq_e D_p \Gamma_0^2 p_B \left(\frac{\partial w}{\partial E_e} \right), \quad (50)$$

$$F_4 \equiv Sq_e D_n \Gamma_{c0}^2 n_c \left(\frac{\partial w'}{\partial E_c} \right) \quad (51)$$

and

$$K_{e1} \equiv (D_n \Gamma_{e1} n_e / D_p \Gamma_1 p_B). \quad (52)$$

¹⁸ For example, detailed consideration of (37) and the corresponding equation for $i_{p1}(w)$ shows that the ratio of the terms involving ϵ^{aE_e} to those involving $(\partial\delta/\partial E_e)$ may be expressed approximately as $[a \div (1/w_0)(\partial\delta/\partial E_e)]$. If a value of $(\partial\delta/\partial E_e)$ of the order of 2×10^{-6} meters/volt is assumed (for a fused-junction transistor, having an internal emitter-base potential of say 0.5v with a forward bias voltage of say 0.2v), and if $w_0 \geq 10^{-5}$ meters, then this term becomes $\sim [40 \div 0.2]$. Hence, the magnitude of the term involving space-charge-layer widening at the emitter is only of the order of 1 per cent of that of the term due to forward-bias admittance.

¹⁹ Shockley (footnote 8), (6-1), (6-2), p. 472.

It should be emphasized that these results also may be used for an *n-p-n* transistor merely by replacing E_c by $-E_c$ (or by $|E_c|$), $(\partial w/\partial E_c)$ by $|\partial w/\partial E_c|$, and by interchanging *n* and *p*, e.g., $F_1 \propto D_n n_B$, $K_{e1} \propto (D_p p_c/D_n n_B)$. (Note that the sign of $(\partial w/\partial E_c)$ is + for the *p-n-p* transistor and - for the case of *n-p-n*.)

1. *Simplification of the ac Equations:* In order to help simplify further calculations, the parameters F_1 and F_2 may be expressed in terms of the dc emitter and collector currents as follows: Equation (43) for I_c (with E_c negative and large) may be manipulated to yield

$$I_0[(\epsilon^{aE_c} - 1)(\text{csch } \Gamma_0 w_0) + \coth \Gamma_0 w_0] = |I_c + I_{cn}| \equiv I_c', \quad (53)$$

where

$$I_{cn} \equiv I_0 K_{c0} = q_e D_n n_c \Gamma_{c0} \quad (54)$$

is that part of I_c due to *electron* current from the collector into the base. In general, I_{cn} will be small (e.g., a few μa). Furthermore, it can be shown that $I_{cn} < I_{c0}$, where I_{c0} is the usual collector current corresponding to zero dc emitter current.

Similarly, (43) for I_e may be manipulated to yield

$$[Sq_e D_p p_B \Gamma_0 \epsilon^{aE_c} (\coth \Gamma_0 w_0 + K_{e0})] = |I_e + I_{es}| \equiv I_e' \quad (55)$$

where

$$I_{es} \equiv I_0 [\coth \Gamma_0 w_0 - \text{csch } \Gamma_0 w_0 + K_{e0}] \quad (56)$$

is a saturation emitter current that flows when both emitter and collector are biased in the inverse direction. Here also it can be shown that $I_{es} < I_{c0}$. For most practical purposes with values of dc emitter current much greater than I_{c0} , I_e' , I_c' may be replaced by $|I_e|$ and $\alpha_0 |I_c|$ respectively.

By combining (53) and (55) with (48) and (49), F_1 and F_2 may be written as

$$F_1 = (\gamma_0 I_e' a \Gamma_0 w_0) [\tanh (\Gamma_0 w_0) / \Gamma_0 w_0], \quad (57)$$

$$F_2 = I_c' \Gamma_0 (\partial w / \partial E_c) \approx \alpha_0 |I_c| \Gamma_0 (\partial w / \partial E_c). \quad (58)$$

For moderately good transistors (e.g., $\alpha > 0.93$) the bracketed term of (57) may be approximated by unity (with an error < 5 per cent). In this case, and when $I_e \gg I_{c0}$, F_1 may be simplified further to read

$$F_1 \approx (\gamma_0 |I_e| a \Gamma_0 w_0) = (\gamma_0 |I_e| \Gamma_0 w_0 q_e / kT). \quad (57a)$$

Further simplification of the results will be made by neglecting the terms F_3 and F_4 . F_3 is a pure conductance and may be neglected with respect to the conductance term involving F_2 , except at extremely small emitter bias voltages. On the other hand, the term involving F_4 is essentially zero at low frequencies, but will have a real and an imaginary part at higher frequencies. However, it should be kept in mind that this term might be of some importance at very low emitter-bias voltages in some types of transistors (e.g., if the minority-carrier concentration in the collector is much greater than that

in the emitter [$n_c \gg p_B$]; here, too, the space-charge layer extends more deeply into the collector region than into the **base** region so that $(\partial w' / \partial E_c) \gg (\partial w / \partial E_c)$).

2. *Effect of Base Spreading Resistance; Equivalent Circuit for Theoretical Model:* In an actual transistor the effect of spreading resistance of the base region must be taken into account. To the first approximation, this may be done in the usual manner by adding a lumped resistance r_b' in series with the base terminal of the theoretical model. This is shown in Fig. 16, together with an exact equivalent circuit for the theoretical model. The circuit contains two "leaky" RC transmission lines and is based on the voltage-current equations (47) with the terms involving F_3 and F_4 omitted. Each line has a propagation constant Γ_1 , but the characteristic impedance of the line in the emitter circuit is lower than that in the collector circuit by the ratio F_2/F_1 . Actually the circuit of Fig. 16 is of more academic than practical interest. A considerably more useful and fairly accurate circuit, described earlier,¹⁵ can be obtained by replacing (low impedance) line in the emitter circuit by a lumped resistance and capacitance in parallel, by replacing the voltage generator in the collector-circuit line by a current generator, and by neglecting shunt leakage in the collector-circuit line. (See Fig. 13 also.)

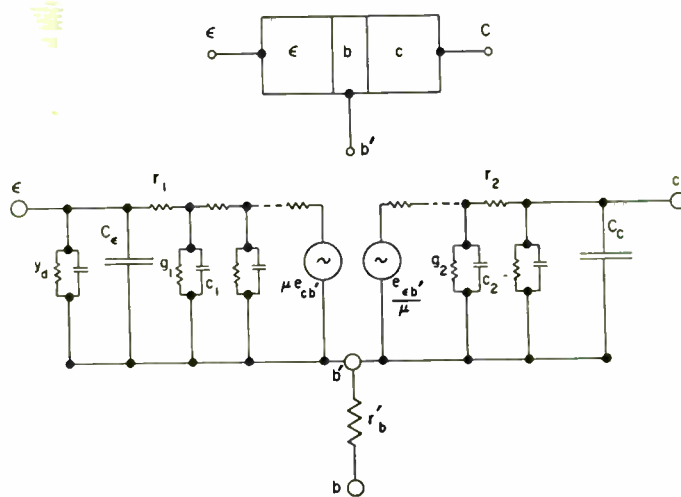

Fig. 16—Exact equivalent circuit for junction transistor.

In order to calculate the performance of the over-all transistor including the effect of r_b' , this writer prefers to use the $[h]$, or series-parallel, parameters. These parameters have been defined by (1) of section I. The admittance, or $[y]$, representation which is so useful for the theoretical model is not so simple when r_b' is included. However, other parameters may be calculated for the over-all transistor as desired.²⁰

Accordingly, the admittance parameters of the theoretical model given by (47) have been converted to $[h]$ parameters, and the results are given below. Modifica-

²⁰ H. Johnson of the RCA Laboratories has described a calculation of the grounded-emitter admittance parameters (from an independent derivation of the voltage-current relations of the theoretical transistor) at the Transistor Research Conference, State College, Pa., July 6, 1953.

tions in the $[h]$ parameters due to the addition of r_b' are given in section I, where each parameter is discussed in detail.

By applying the transformation,²¹

$$\begin{bmatrix} h_{11} & h_{12} \\ h_{21} & h_{22} \end{bmatrix} = \begin{bmatrix} (1/y_{11}) & - (y_{12}/y_{11}) \\ (y_{21}/y_{11}) & y_{22} - (y_{12}y_{21}/y_{11}) \end{bmatrix}$$

to (47) with F_3 and F_4 terms neglected, it follows that

$$h_{11} = (\Gamma_0 w_0 / F_1) \cdot \gamma \cdot [\tanh (\Gamma_1 w_0) / \Gamma_1 w_0], \quad (59)$$

where

$$\gamma \equiv \{1 + [K_{e1} \Gamma_1 w_0 + j\omega C_e (\Gamma_0 w_0 / F_1)] \cdot [\tanh (\Gamma_1 w_0) / \Gamma_1 w_0]\}^{-1}, \quad (60)$$

$$h_{21} = -\gamma \cdot \operatorname{sech} \Gamma_1 w_0, \quad (61)$$

$$h_{12} = - (F_2 / F_1) \cdot h_{21}, \quad (62)$$

$$\begin{aligned} h_{22} = & j\omega C_e + (F_2 / \Gamma_0 w_0) \{ (\Gamma_1 w_0)^2 [\tanh (\Gamma_1 w_0) / \Gamma_1 w_0] \\ & + (\Gamma_1 w_0) \cdot K_{e1} \cdot \gamma \cdot (\operatorname{sech} \Gamma_1 w_0)^2 \} \\ & + j\omega C_e (F_2 / F_1) \gamma \operatorname{sech}^2 \Gamma_1 w_0. \end{aligned} \quad (63)$$

In general, the latter term in (63) is extremely small relative to $j\omega C_e$ and may be neglected.

D. Acknowledgments

The writer is very grateful to R. N. Hall for helpful discussions concerning this subject, for providing the physical picture of the diffusion capacity, and for providing grown-junction transistors used in some of the experimental work. The fused-junction transistors were supplied by J. S. Saby. Assistance of Miss Joyce Gillespie in carrying out most of the numerical calculations for the exact forms of the hyperbolic functions also is gratefully acknowledged.

E. Appendix A

Relationship between β -cut-off frequency and base width w for theoretical model of junction transistor.

In general,^{2a,b} $\beta = \operatorname{sech} [(1 + j\omega\tau_b)^{1/2} w / L_b]$.

The β -cut-off frequency $\omega_c / 2\pi$ is defined as the frequency for which $|\beta|$ has decreased to $\frac{1}{2}\beta_0^2$, where β_0 is the low-frequency value of $\beta(\omega=0)$. Numerical calculations of β versus $(\omega w^2 / D)$ (where $D \equiv L_b^2 / \tau_b$) for several values of β_0 yielded the following values of ω_c :

β_0	$(\omega_c w^2 / D)$
1.00	2.43
0.952	2.53
0.908	2.63
0.867	2.73
0.830	2.81

F. Appendix B

1. *Discussion of Diffusion Capacity C_d* : The diffusion capacity C_d due to charge stored in the base region by the dc emitter current was introduced in the approximate relationship (10) for collector-base admittance h_{22}' , in order to provide a convenient analytical descrip-

tion for the high-frequency behavior of h_{22}' . More accurately, C_d may be defined as $1/j\omega$ times the limiting low-frequency value of the collector-base admittance due to space-charge-layer widening for the case of $\gamma_0 = 1$. Thus, from (63) with $K_{e1} = 0$, the admittance ($h_{22} - j\omega C_e$) due to space-charge-layer widening may be written as

$$(h_{22} - j\omega C_e) = (F_2 / \Gamma_0 w_0) (\Gamma_1 w_0)^2 [\tanh (\Gamma_1 w_0) / \Gamma_1 w_0].$$

The limiting low-frequency value of the right-hand side of this expression is

$$(F_2 / \Gamma_0 w_0) [1 + j\omega\tau_b] (w_0 / L_b)^2 [\tanh (w_0 / L_b) / (w_0 / L_b)].$$

From this equation, and by using the relation $D_b \equiv L_b^2 / \tau_b$, the diffusion capacity C_d as defined above becomes

$$C_d \equiv (w_0^2 / D_b) (F_2 / \Gamma_0 w_0) [\tanh (w_0 / L_b) / (w_0 / L_b)]. \quad (64)$$

Substituting for $F_2 / \Gamma_0 w_0$ from (58) the diffusion capacity C_d may be written more explicitly as

$$C_d \approx \alpha_0 |I_e| (w_0 / D_b) [\tanh (w_0 / L_b) / (w_0 / L_b)] (\partial w / \partial E_c). \quad (65)$$

Hence, C_d is directly proportional to the thickness of the base region, to the dc emitter current, and to the rate of change of the base thickness with respect to collector voltage.

A useful approximate expression for C_d also may be written in terms of the concentration p_B of minority carriers in the base by using the approximation

$$I_e \approx (Sq_e D_p p_B / w_0) \epsilon^{\alpha E_c},$$

which is valid for moderately high α (e.g., $\alpha > 0.93$) and for moderately high currents (such that $\epsilon^{\alpha E_c} \gg 1$), cf. (55); thus:

$$C_d \approx q_e S p_B (\partial w / \partial E_c) \epsilon^{\alpha E_c}. \quad (66)$$

An alternative calculation of C_d may be obtained by direct consideration of the physics of the transistor in a manner suggested by R. N. Hall. Consider the model of the transistor shown in Fig. 17, for which a value of $\alpha_0 = 1$ is assumed for convenience. At dc equilibrium, $\Delta E_c = 0$, the concentration of holes $p(x)$ through the base layer is essentially linear as shown by the solid line. At the emitter-base junction, $x = 0$, $p(x) = p_e$, and at the base-collector junction, $x = w_0$, $p(x) = 0$. The slope of the line $p(x)$ is proportional to the dc emitter current.

If now the magnitude of the collector-base voltage is increased by applying $-\Delta E_c$ as shown, the collector-base junction moves toward the emitter by an amount Δw . The emitter current is assumed to be held constant. Accordingly, the slope of the $p(x)$ line must remain the same. Furthermore, since the hole concentration must vanish at the new position of the base-collector junction, the hole concentration $p(x)$ corresponding to the new collector voltage must be as shown by the dotted line. This has two effects.²² First the value of $p(x)$ at the emitter-base junction must decrease from p_e by an amount Δp . The corresponding decrease in the emitter

²¹ For example, Brown and Bennett (footnote 7), p. 851.

²² If a value of α different from unity had been assumed, a third result would be collector-base conductance due to space-charge-layer widening as calculated by Early.

voltage produces the feedback voltage described by Early. Second, in order to permit the new boundary conditions to be attained, a quantity of charge ΔQ shown by the shaded area in Fig. 17 must be removed from the base region into the collector circuit. The ratio of this charge ΔQ to the change in voltage ΔE_c causing the charge to appear in the circuit is the effective diffusion capacity C_d . Thus

$$C_d = I_e(w_0/D)(\Delta w/\Delta E_c)$$

which is equivalent to the result obtained above in (65) for the case $(w/L_b)^2 \ll 1, \alpha \doteq 1$.

The term diffusion capacity is used to indicate that the charge contributing to C_d must diffuse from the base region to the base-collector junction. As the frequency of the ac collector voltage is increased, the time required for the charge at the emitter end of the base to diffuse to the base-collector junction becomes comparable with the period of the ac voltage, and C_d effectively becomes complex. The quantitative description of this process is best found by solution of diffusion equation above.

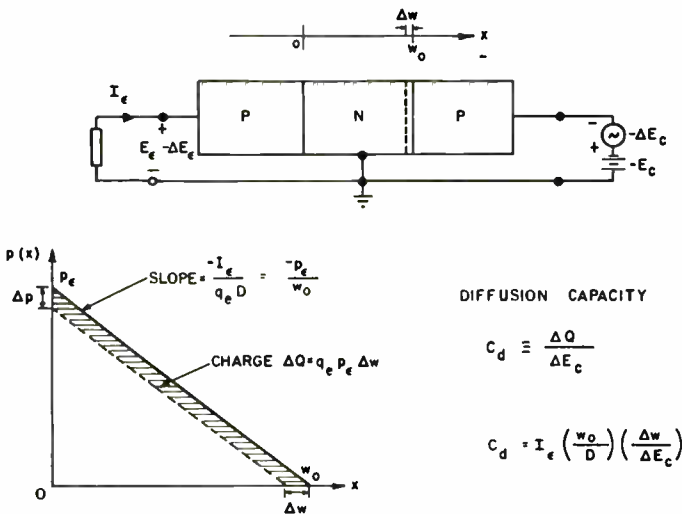

Fig. 17—Model of junction transistor to illustrate physical concept of collector-base diffusion capacitance.

2. *Variation of C_d with dc Bias:* The diffusion capacity is seen to be directly proportional to dc emitter current. Obversely, the variation of C_d with dc collector voltage E_c depends upon the variation of $(\partial w/\partial E_c)$, which is determined by the nature of the collector-base junction.

For the uniformly graded junction, Early has given an expression for $\partial w/\partial E_c$. In the case of a nonuniformly graded junction, such as usually exists in a grown junction transistor, the value of $(\partial w/\partial E_c)$ depends upon the variation of carrier concentration with distance through the base-collector region and is not calculated easily in general.

For a step junction having a high conductivity on one side and uniform but much lower conductivity on the other side, the space-charge layer is essentially confined to the low-conductivity material. This is the case that normally exists in fused-junction transistors, when the base material is of relatively low conductivity (e.g.,

$\rho_b \geq 1$ ohm cm). Here, Early²³ has given the results

$$(\partial w/\partial E_c) = -x_m/2E_c, \tag{67}$$

$$x_m^2 = 2\epsilon_r\epsilon_0 E_c/q_e N_B, \tag{68}$$

where x_m is the thickness of the collector barrier, ϵ_0 is the free-space dielectric constant, ϵ_r is the relative dielectric constant of the semiconductor material, and N_B is the concentration of majority carriers in the base region (N_B = donor concentration N_d , for n -type semiconductor). Alternatively, x_m may be related to the collector barrier capacity C_c by the equation²⁴

$$C_c = \epsilon_0\epsilon_r S/x_m \tag{69}$$

Also,²⁴

$$C_c = S(q_e N_B \epsilon_r \epsilon_0 / 2 |E_c|)^{1/2}. \tag{70}$$

If (67) and (68) are combined (with the minus sign suppressed) and are substituted back into (65) for C_d , it will be seen that for a step junction

$$C_d = (\alpha_0 |I_e| / |E_c|^{1/2})(w_0/D_b) [\tanh(w_0/L_B)/(w_0/L_B)] \times (\epsilon_r \epsilon_0 / 2q_e N_B)^{1/2}, \tag{71}$$

i.e., C_d is inversely proportional to the square root of collector voltage, Fig. 10, to square root of majority carrier concentration in base, and is directly proportional to dc emitter current and to base thickness.

Another very interesting result may be obtained by calculating the ratio C_d/C_c , using the approximate (66) combined with (67), (68) and (70):

$$C_d/C_c \doteq p_B \epsilon^{aE_c} / N_B. \tag{72}$$

The numerator of this expression represents the minority-carrier concentration injected into the base at the emitter-base junction, whereas the denominator is the equilibrium majority-carrier concentration. Now, one of the fundamental assumptions of the theoretical analysis given by Shockley, and hence of the extension described above, is that minority-carrier concentration be small relative to majority-carrier concentration. However, if C_d is comparable with C_c , this low-level injection requirement obviously is not well satisfied, and the theory from which the expression for C_d was derived is not strictly valid!²⁵ However, since the experimental results for C_d are in fairly good agreement with those predicted by (71), up to values of C_d/C_c somewhat less than unity (cf. Fig. 10), it appears that the violation of the low-level injection assumption is not particularly serious so long as the injected minority-carrier concentration does not exceed the equilibrium majority-carrier concentration in the base. Alternatively, these results indicate that direct measurement of the ratio C_d/C_c may be used to estimate the injection level if it is not known from other considerations.

²³ Early, (footnote 4), (17) and (15), p. 1406. Note that $(\partial w/\partial E_c) < 0$ for the n - p - n structure considered by Early, whereas $(\partial w/\partial E_c) > 0$ for the p - n - p case.

²⁴ For example, W. Shockley, 1949 (footnote 8), (2.55)–(2.56) p. 451, modified for the MKS system used above.

²⁵ An extension of Shockley's analysis for the case of high-level injection has been made recently by W. M. Webster of the RCA Laboratories, who has calculated the variation of α with dc emitter current. This paper was presented at the Transistor Research Conference, State College, Pa., July 7, 1953.

Electron Beam Focusing with Periodic Permanent Magnet Fields*

J. T. MENDEL†, ASSOCIATE, IRE, C. F. QUATE†, ASSOCIATE, IRE, AND W. H. YOCOM†, ASSOCIATE, IRE

Summary—This paper presents experimental and theoretical results on focusing a long electron beam with a permanent magnet structure which produces a periodic magnetic field along the axis of the electron beam. In principle, the periodic permanent magnet made up of N cells will be reduced in weight by a factor of N^2 over a permanent magnet producing a uniform field over the same length. The periodic focusing results are comparable to results obtainable with a uniform field. In addition the periodic fields for certain combinations of beam voltage and magnetic field exhibit regions of "stop bands" wherein the beam becomes unstable and no current reaches the collector.

INTRODUCTION

TRAVELING-WAVE tubes and most present-day microwave tubes require long electron beams of high current density. The radial forces of space charge in such dense beams must be neutralized if the beam is to be held together over a distance, and generally this is accomplished by immersing the beam in a uniform magnetic field. In principle such a field is most efficiently utilized in "Brillouin Flow"¹ wherein the cathode is shielded from the magnetic field. In practice, however, beams with shielded guns are focused with fields about 50 per cent greater than that for theoretical Brillouin Flow. The fields necessary for such focusing can be obtained from either an electromagnet such as a solenoid, or a permanent magnet. Both structures involve an inconvenient amount of weight, and in addition solenoids consume power.

These disadvantages of weight and power consumption can be overcome by using a periodic magnetic field which is symmetric about the axis of the electron beam. Such a field can be produced, as shown in Fig. 1, by a series of short magnetic lenses. The reduction in weight made possible by the use of alternating magnetic field is vividly illustrated in Fig. 2. The large magnet weighing 38 pounds is necessary to produce the uniform field² for focusing a beam in a medium power traveling-wave tube. The periodic magnetic structure, weighing 1 pound 5 ounces, will focus the same beam equally well. Thus the weight has been reduced by a factor of 30.

The possibility of focusing with alternating transverse magnetic fields has been pointed out by Livings-

ton, Courant, and Snyder.³ In their article on "Strong Focusing" they discuss the use of quadrupole fields for focusing high energy electron beams in which space charge forces are unimportant. Periodic fields of axial symmetry produced by electrostatic lenses have been discussed by Hahn.⁴ Clogston and Heffner have shown

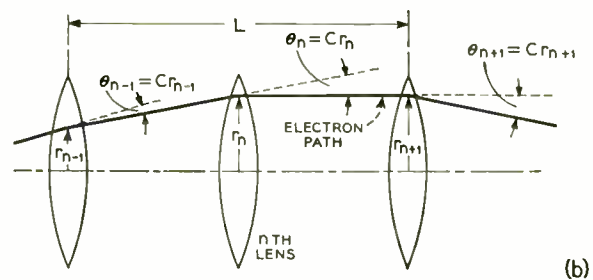
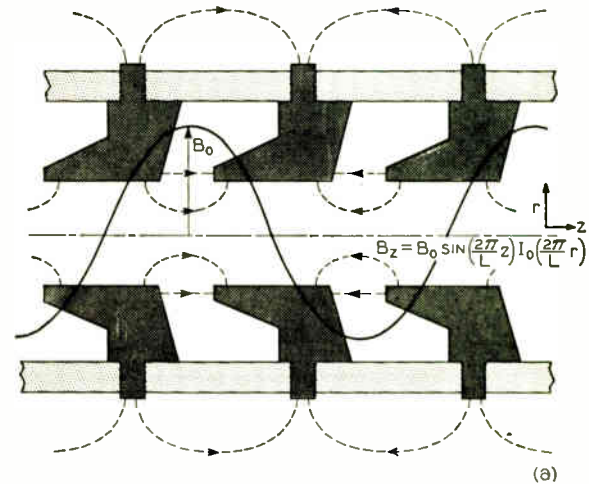

Fig. 1—A typical permanent magnet structure for producing an alternating magnetic field on the axis as shown in (a). A thin lens equivalent of this system is depicted in (b) to illustrate some of the properties of periodic focusing.

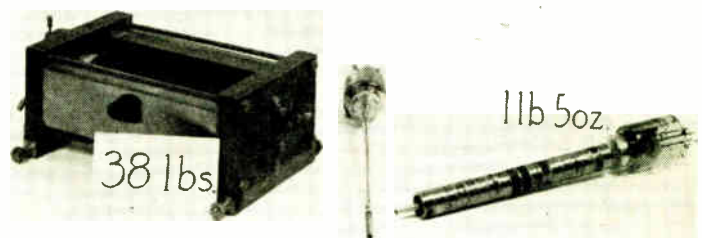

Fig. 2—This photograph illustrates the saving in weight which is possible in periodic focusing. The large magnet weighing 38 pounds is necessary to produce a field of 450 gauss over 9 inches of length. The periodic magnet weighing 1 pound 5 ounces will focus the same beam as the uniform field magnet.

* Decimal classification: R138×R339.2. Original manuscript received by the IRE, September 24, 1953; revised manuscript received, December 31, 1953.

† Bell Telephone Labs., Murray Hill, N. J.

¹ J. R. Pierce, "Theory and Design of Electron Beams," D. Van Nostrand Co., New York, N. Y., chap. IX; 1954.

² The permanent magnet structure for producing uniform field shown in Fig. 2 was developed by C. C. Cutler and G. M. Eberhardt. The structure in the center is a series of mu metal discs necessary to eliminate the stray transverse fields which are present between the two Alnico bar magnets. Structures such as this can be used for fields up to 500 gauss. For higher fields the bars have to be replaced by horseshoe magnets.

³ E. D. Courant, M. S. Livingston, and H. S. Snyder, "The strong focusing synchrotron," *Phys. Rev.*, vol. 88, pp. 1190-1196; December, 1952.

⁴ W. C. Hahn and G. F. Metcalf, "Velocity modulation tubes," *Proc. I.R.E.*, vol. 27, pp. 106-117; February, 1939.

in a recent paper⁵ that it is possible to overcome the forces of space charge and focus with periodic fields.

In order to focus a given beam with periodic magnetic fields it is necessary to use an rms value of the alternating field which is equal to the uniform "Brillouin" field required to focus the same beam. Therefore, since the effective field strength is not changed, only a minor improvement can be expected by the use of a series of electromagnets producing a periodic field in place of the use of a solenoid producing a uniform field. However, Pierce has pointed out that the weight of the permanent magnet required to produce an alternating field of a given rms value is much less than the weight of the magnet required to produce a uniform field. This saving in weight can be illustrated by the following argument.

In Fig. 3(a) there is illustrated a permanent magnet assumed to be of the most efficient design to produce a uniform axial field over the length of the magnet. Now suppose the same field is desired over a length N times as great. For the uniform field case it is necessary to scale all dimensions of the magnet by a factor N as shown in Fig. 3(b). For the periodic field, however, it is merely necessary to increase the length of the structure by a factor N as shown in Fig. 3(c). The volume of the uniform structure must, therefore, be increased by N^3 and the volume of the periodic structure by a factor N . Thus in the periodic structure the weight is smaller by a factor of N^2 over the uniform field where N is the number of lenses making up the periodic structure.⁶ In practice such factors as the shape of the pole pieces and requirements for mechanical rigidity enter in such a way as to reduce the N^2 weight saving factor. In the experimental structure which will be discussed here the factor is about midway between N and N^2 .

Before discussing the experimental results the important features of periodic focusing can be illustrated with the use of a few equations from Pierce's book on electron beams. Consider the periodic system of Fig. 1(b) which consists of a series of thin converging lenses. An electron moving through such a system of lenses will move in straight lines between successive lenses provided that the forces of space charge are not considered and secondly, that the fields are assumed to be closely confined to the region of the lens. The radial position of electron path at the n th lens is defined by r_n as in Fig. 1(b), the slope of the path by r_n' and the convergence of the lens C by the reciprocal of the focal length.

With these approximations the position of the path at the $n+1$ lens will be

$$r_{n+1} = r_n + \frac{L}{2} r_n' \quad (1)$$

⁵ A. M. Clogston and H. Heffner, "Focusing of an electron beam by periodic fields," to be published in the *Jour. of Appl. Phys.*

⁶ The decrease in magnetic material required for the periodic structure can also be seen from a consideration of the external fields as discussed in Appendix A. Here it is shown that for the periodic case the external stored energy is reduced by a factor of $1/N^2$ over that of the uniform field structure. Also, it is important to note that periodic structures can be located in close proximity to each other without having appreciable interaction of the magnetic fields.

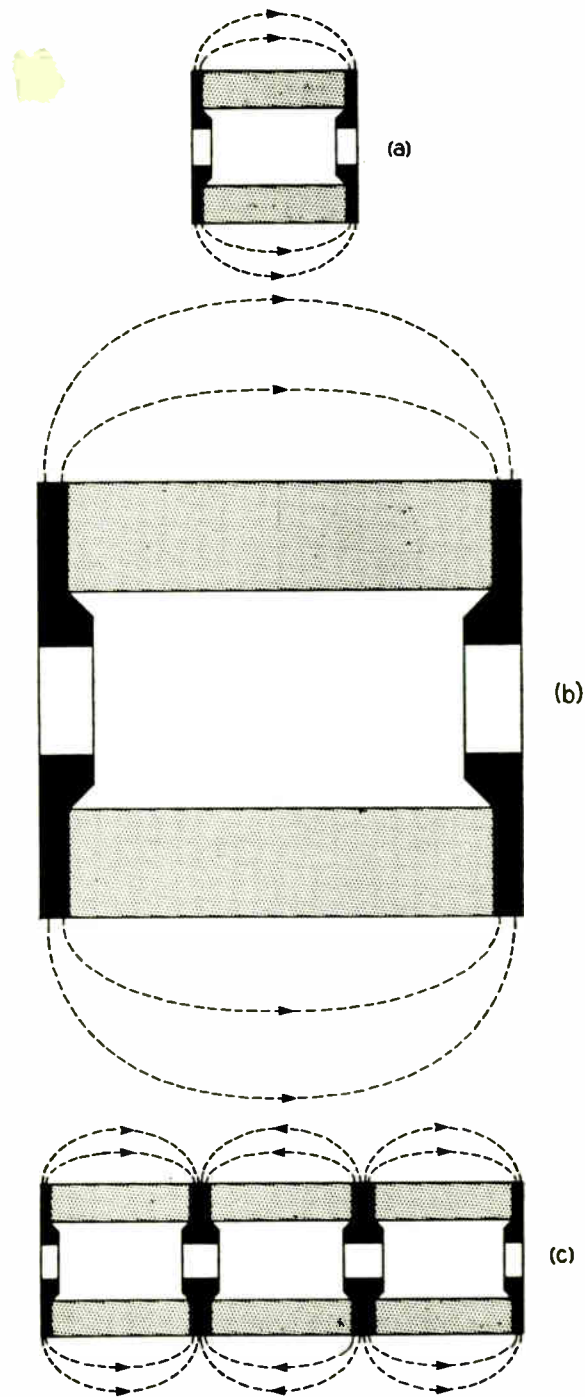

Fig. 3—The weight-saving feature of periodic focusing can be pointed out by increasing the length of the magnetic field by a factor of N . The uniform structure must be scaled in all dimensions by a factor of N as in (b), which means an increase in volume of N^3 , whereas the periodic structure must be increased only in length by a factor of N as in (c). Thus the periodic structure has a weight advantage of N^2 .

The change in slope of the path in passing through the n th lens will be $C r_n$ and thus

$$r_{n+1}' = r_n' - C r_{n+1} \quad (2)$$

which gives from (1)

$$r_n' = \frac{2}{L} (r_{n+1} - r_n)$$

and similarly

$$r_{n+1}' = \frac{2}{L} (r_{n+2} - r_{n+1})$$

and hence (2) can be written

$$r_{n+2} - \left(2 - \frac{CL}{2}\right)r_{n+1} + r_n = 0. \quad (3)$$

The difference equation (3) has the solution of the form

$$r_n = A \cos n\theta + B \sin n\theta. \quad (4)$$

If the entering conditions are properly chosen, only the $\cos n\theta$ solution is necessary, then (3) and (4) give

$$\cos \theta = \left(1 - \frac{CL}{4}\right). \quad (5)$$

Therefore the electron will move through a series of converging lenses with a stable orbit providing

$$CL < 8.$$

At $CL=8$ the electron orbits are not periodic and the radius increases without limit and this point is defined as the beginning of a "stop band." For a magnetic lens system the convergence can be written⁷

$$C = \frac{\eta}{8V_0} \int_0^{L/2} B^2 dz. \quad (6)$$

With the sinusoidal variation of field along the axis as shown in Fig. 1(a) where

$$B_z = B_0 \cos \frac{2\pi z}{L} \quad (6a)$$

(6) becomes

$$CL = \frac{\eta L}{8V_0} \int_0^{L/2} B_0^2 \cos^2 \frac{2\pi z}{L} dz$$

or

$$CL = \frac{\eta}{8V_0} B_0^2 \frac{L^2}{4}. \quad (7)$$

Therefore at the "stop band" given by $CL=8$ (7) becomes

$$\frac{\eta B_0^2 L^2}{V_0} = 256 \quad (8)$$

and stable flow must occur for

$$\frac{\eta B_0^2 L^2}{V_0} < 256.$$

In a later section the thick lens case is treated including the effects of space charge and it is there shown that for stable flow with a minimum of ripple in the beam the rms value of the periodic field is equal to the dc magnetic field required for the uniform Brillouin case. Also when

⁷ Pierce, *loc. cit.*, chap. VII.

the thick lens is considered it is shown that (8) should be more accurately written

$$\frac{\eta B_0^2 L^2}{V_0} = 418. \quad (9)$$

EXPERIMENTAL RESULTS

In the initial studies of periodic focusing it was desirable to vary the magnetic field over a wide range and for this purpose a system of electromagnetic lenses was constructed which produced a sinusoidal flux pattern at the axis, i.e.

$$B_z = B_0 \cos \frac{2\pi z}{L}.$$

The magnet spacing L was chosen to be 1 inch since this seemed a suitable value for a typical medium power traveling-wave tube (9 inch helix 0.080 inch in diameter) which was available for the experiment.

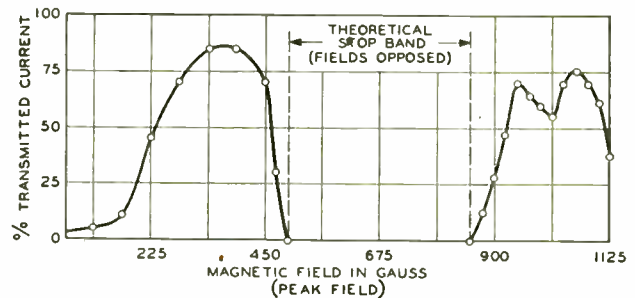

Fig. 4—Per cent collector current through a hole 9 inches in length and 0.080 inch in diameter as a function of the peak magnetic field of the periodic system. The first theoretical stop band is also shown for comparison. (Alternating opposed fields.)

Fig. 4 shows the results of changing the magnetic field with the beam current and voltage remaining constant. For small values of magnetic field the behavior is exactly like that of a uniform field solenoid, i.e., improved transmission with increasing magnetic field. However, at about 400 gauss peak field the transmitted current tends rapidly to zero and there is encountered a region of no transmission between 475 gauss and 850 gauss. At still higher magnetic fields alternate regions of electron transmission and no transmission are observed, although these are not shown in Fig. 4. This phenomenon has been found to be characteristic of periodic focusing. The regions of no transmission, termed "stop bands," occur for certain definite magnetic field strengths depending upon the magnet spacings and beam voltage. The first stop band begins when the magnetic field (peak value) is sufficiently high so that

$$\frac{\eta B_0^2 L^2}{V_0} = 418 \text{ MKS units} \quad (9)$$

as explained earlier. At the beginning of the next pass band the curve of percentage transmission is quite similar in shape to the first pass band. The width of the stop

and pass bands is calculated in a later section, and as can be seen from Fig. 4, the experimental curve agrees quite closely with theory.

For the sake of completeness the magnetic field of each individual lens was directed in the same direction to give the "aiding field" case shown in Figs. 6 and 7.

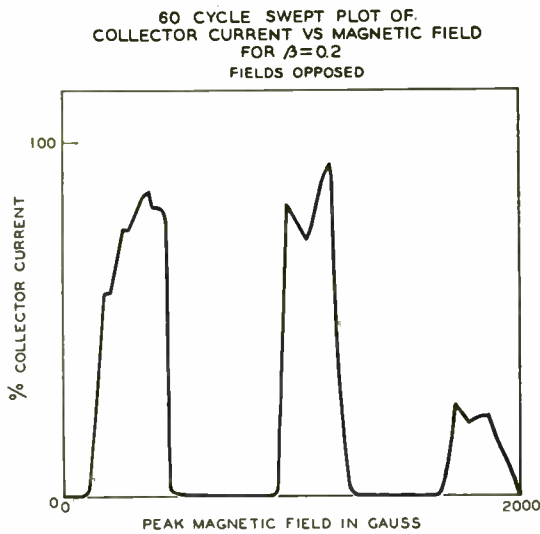

Fig. 5—Oscilloscope picture of the collector current when the magnetic field was swept at a 60 cycle rate. (Alternating opposed fields.) The third stop band and pass band appear in this picture.

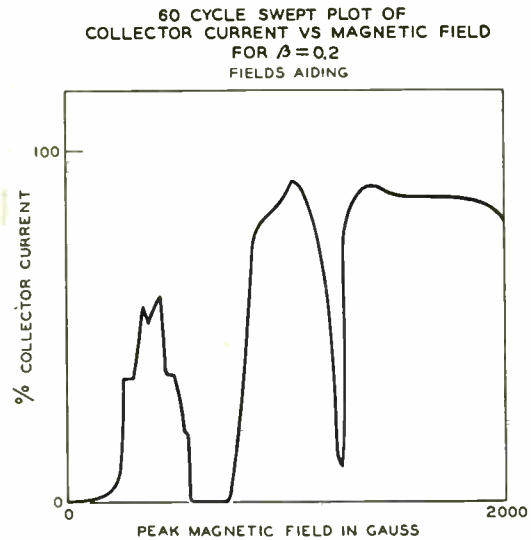

Fig. 7—Oscilloscope picture of the aiding field case with a swept magnetic field.

A more graphic picture was obtained when the magnetic field was swept at 60 cps and the percentage collector current observed on an oscilloscope, as shown in Fig. 5. Had more magnetic field been available presumably more peaks and stop bands would have appeared to the right and the general pattern would have been repeated. In this experiment the higher pass bands were reached by increasing the magnetic field and for this condition the electrons cross the axis once in the second pass band and twice in the third pass band. As can be seen from Fig. 5, satisfactory focusing was achieved for the second pass band but not for the third. It should be pointed out that it may well be possible to operate in

Here again the situation is of slight practical interest since such a configuration requires heavy permanent magnets.

This arrangement also gives alternate pass and stop bands which are slightly altered in position. The theory also predicts their location with good accuracy.

The optimum focusing conditions at the peak of the first pass band for this tube with alternately poled magnets were:

- Helix potential —700 volts
- Collector current—5.2 ma (88 per cent transmission)
- Helix current —0.7 ma
- B_0 —380 gauss (peak field)
270 gauss (rms)
- Brillouin field —177 gauss (theoretical).

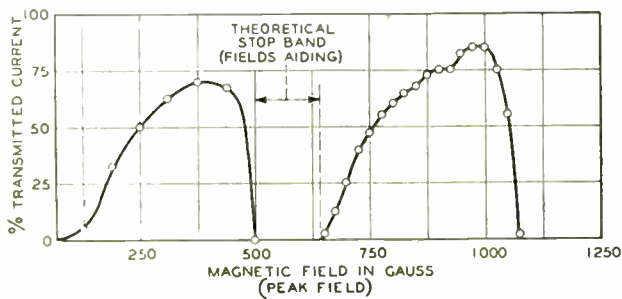

Fig. 6—Per cent collector current versus peak magnetic field when the fields are poled in the same direction (aiding fields) with same structure and beam as Fig. 4. This curve was taken for a structure with a 1-inch period, a beam voltage of 700 volts, and a beam current of 6 ma.

the second pass band by increasing the period rather than the magnetic field. The location of these higher order pass bands with respect to magnetic field, beam velocity, and magnet spacing is presented in a later section.

Although theory predicts perfect transmission with an rms field equal to the Brillouin field it has been determined experimentally that, for both uniform solenoidal fields and periodic fields, near perfect transmission is not realized until the magnetic field is about twice the Brillouin field. This is probably a result of thermal velocities and aberrations in the gun structure which preclude the attainment of ideal parallel flow at the start of the focusing structure.

The data presented in the previous figures were obtained from a traveling-wave tube whose gun structure was rather imperfectly designed. It was felt desirable to obtain information concerning the focusing properties of a tube with a higher perveance and also one whose gun produced a well-defined beam.

The tube selected for further testing was a medium power (10 watts) traveling-wave tube designed for application in radio-relays. The operating beam voltage is

about 1,760 volts with 38 ma, or a perveance of about 0.6×10^{-6} . A uniform field of about 350 gauss is the theoretical field for Brillouin focusing, so in the light of our experience the actual field required for good transmission (>99 per cent) should be approximately 700 gauss. To obtain an rms field of this value with a sinusoidal periodic field would necessitate a peak field of about 1,000 gauss.

With the magnet period of 1 inch used with the previous tube and a beam voltage of 1,700 volts,

$$\frac{\eta B_0^2 L^2}{V_0} > 418;$$

thus the operation would be beyond the first pass band and therefore no current transmission. The only parameter which could be conveniently changed was L , and so a system of closer lens spacing was constructed.

With a magnet period of $\frac{3}{4}$ inch and an rms magnetic field twice the Brillouin value, 99 per cent of the beam current was focused to the collector. Although this does not represent the maximum attainable percentage transmission it was considered sufficiently good for experimental verification of this type of focusing. It seemed desirable to obtain a careful check of the stability requirement $(\eta B_0^2 L^2 / V_0) < 418$ with this tube since the focusing was known to be good.

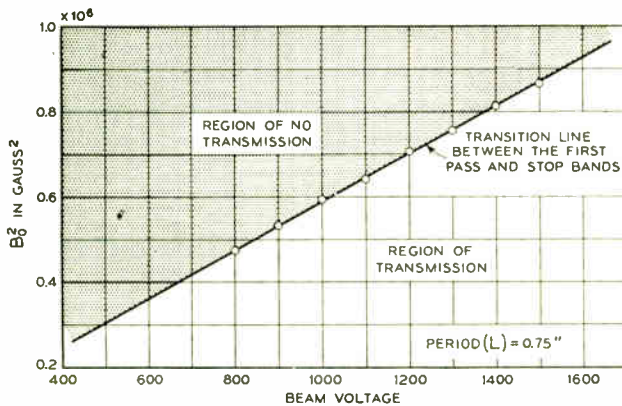

Fig. 8—Measurement of relationship of magnetic field and beam voltage for the beginning of the first stop band. For this test a beam with a perveance of 0.6×10^{-6} was used in conjunction with a 0.080-inch diameter helix 9 inches long.

The procedure followed was to adjust the magnetic field at each value of beam voltage so that the collector current just disappeared. These points represent the beginning of the first stop band and are plotted in Fig. 8. It will be noted that the relationship between B_0^2 and V_0 is a linear one and therefore establishes the criterion for stability. From this plot the stop band began at

$$\frac{\eta B_0^2 L^2}{V_0} = 360$$

rather than the analytically determined value of 418, but since this represents a difference of only 8 per cent in B (measurements of the field were only accurate to within about 5 per cent) it lies within the range of expected error. The important feature of this graph is the

very close approximation to a straight line relationship between B_0^2 and V_0 . This gives experimental confirmation to the theory that the mechanism of the stop band phenomenon is not dependent upon space-charge conditions.

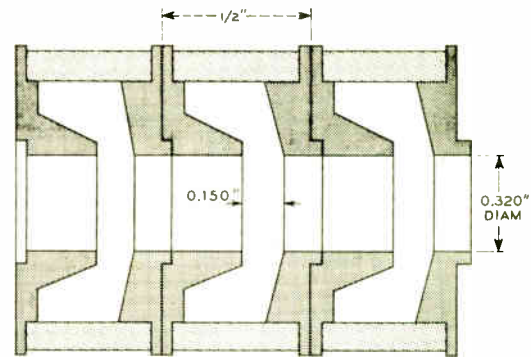

Fig. 9—Detail of a permanent magnet element used for periodic focusing. The Alnico V ring magnets and Permalloy pole pieces form a unit which can produce 700-800 gauss at the gap.

EXPERIMENTAL RESULTS FOR A PERMANENT MAGNET CIRCUIT

The permanent magnet structure used to focus the medium power tube mentioned in the previous section shown in Fig. 9 has a 1-inch period and is made of Alnico V ring magnets with Permalloy pole pieces. Each cell was magnetized individually, and cells were stacked together to produce the alternating magnetic field. In these tests no great care was taken to equalize the strength of each cell and as a result there was about a 10 per cent variation in peak field from cell to cell as shown in Fig. 10.

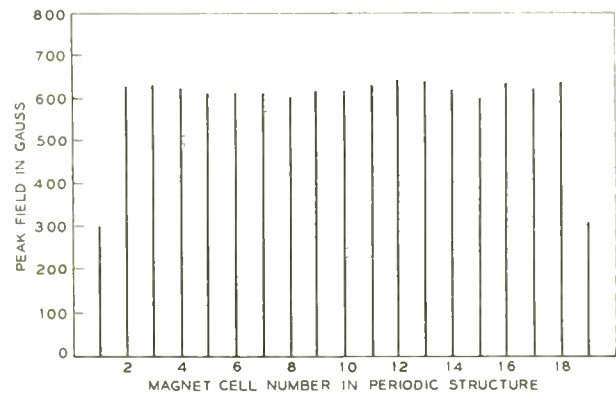

Fig. 10—Measurement of uniformity of peak fields occurring at each gap in a periodic structure made up of the elements shown in Fig. 9.

With the fixed magnetic field the collector current versus voltage was obtained as shown in Fig. 11 for a constant beam perveance. It should be noted that as the voltage is increased from zero all the stop bands are traversed, as predicted from (9), until the beginning of the primary pass band is reached near 1,000 volts, for an rms magnetic field of 423 gauss. As the voltage is increased above the stop band the collector current rises

rapidly. An increase of 100 volts above the edge of the stop band gives a current transmission of 70 per cent.

To reach higher values of current than shown in Fig. 11, it is necessary to go to higher values of magnetic field. Also, if the voltage at the stop band is to remain constant the period of the magnet structure must be decreased. If it were possible to scale the magnet shown in Fig. 9 the field strength would not vary. However, the tube in general does not permit the internal diameter of the structure to be decreased. Thus, as the length is decreased without a corresponding decrease in diameter the available peak field in the gap must decrease.

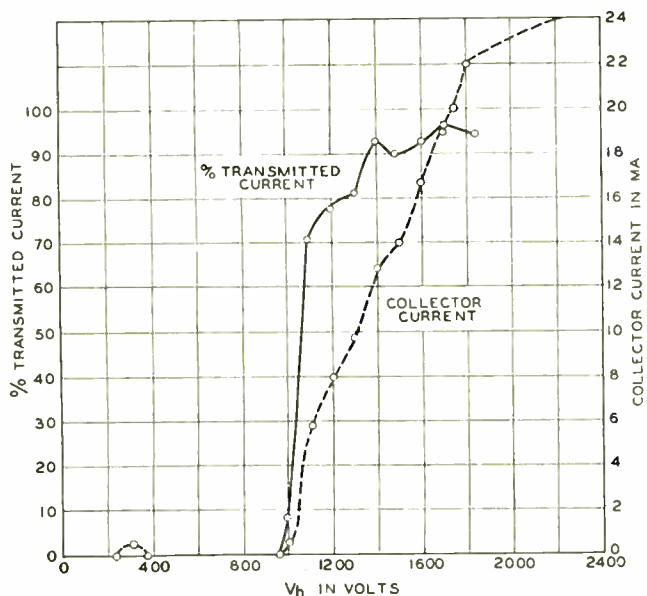

Fig. 11—Collector current versus beam voltage for an rms magnetic field of 423 gauss in the structure of Fig. 9. The beam transmission was measured through a hole 9 inches in length and 0.080 inch in diameter.

For example, in the magnet of Fig. 9 it is possible to obtain a peak field of 800 gauss near the axis which means a stable field of perhaps 700 gauss after partial demagnetization. For higher peak fields, it has been determined that Ferroxdure⁸ magnets are suitable. With Ferroxdure cells as shown in Fig. 12 it was possible to achieve peak fields of 1,000 gauss with a period of 0.7 inch. It appears from Fig. 11 that it is desirable to operate at voltages at least 20–30 per cent above the stop band. The voltages at the stop band for the 1-inch period of Fig. 11 is computed from (9) to be 1,000 volts compared to 950 volts measured. Hence the agreement is within 5 per cent, which is within the experimental error of measuring the magnetic fields.

For the permanent magnet structures discussed here, it has been necessary for optimum focusing to use magnetic fields 50–100 per cent in excess of the value predicted in (9). However, in focusing with uniform fields it is also necessary to use similarly large fields. Thus, the initial experiments have resulted in focusing comparable

to that obtained in the uniform magnetic field. It should be noted that in the uniform field case tubes have been built which focus satisfactorily with fields closer to the Brillouin values than mentioned above. However, it is expected that further refinement in the mechanics of the periodic structures will result in further improvement. For example in the structure of Fig. 9 it was possible to improve the focusing somewhat by rotating the individual magnet cells. This indicates the presence of transverse components of magnetic field on the axis which probably results from nonsymmetry in the pole pieces.

RF MEASUREMENTS

Since periodic magnetic-focusing structures introduce a ripple in the beam radius due to the periodicity of the magnets which is not characteristic of uniform field circuits, it was desirable to investigate the rf amplification properties of a typical traveling-wave tube under these circumstances. The tube tested was a medium power traveling-wave tube designed for operation at 3

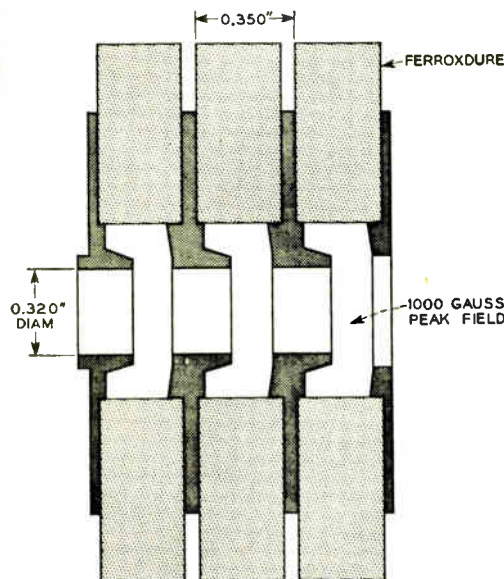

Fig. 12—Element of a periodic structure using Ferroxdure magnets to produce a field of 1,000 gauss with the period of 0.7 inch.

cm. The input and output matches were constructed with standard $\frac{1}{2} \times 1$ inch waveguides since $\frac{1}{2}$ inch was the length of the magnetic lenses used in the periodic structure. Pole pieces were fitted into the waveguide and excited by external magnets, thus making an unbroken series of alternating lenses. With 5 ma of current focused to the collector with a beam voltage of 1,800 volts the rf gain of the tube at 3 cm was measured to be 22 db, with a power output of 200 milliwatts. This corresponds closely to operation in a uniform solenoid.

DYNAMICS

The equations of motion for the electron beam in the periodic magnetic field of Fig. 12 are derived with the following assumptions.

⁸ J. J. Went, G. W. Rathenau, E. W. Gorter, and G. W. van Oosterhout, "Ferroxdure, a class of new permanent magnate materials," *Phillips Tech. Rev.*, vol. 13, p. 194; 1952.

(a) The magnetic field is axially symmetric and uniform over the beam cross section. The longitudinal component can thus be written as,

$$B_z = B_0 \cos \frac{2\pi z}{L} \quad (6a)$$

(b) The electric field due to space charge acts only in a radial direction, i.e.,

$$E = E_r.$$

The Lagrangian for an electron in an electric and magnetic field is given by⁹

$$L = \frac{m}{2} (\dot{x}^2 + r^2 \dot{\theta}^2 + \dot{z}^2) + e(v \cdot A) - eV \quad (10)$$

where A is the magnetic vector potential and V the electric potential. For the assumed conditions,

$$A = A_\theta = \frac{B_z r}{2}.$$

For no magnetic field at the cathode one obtains from Busch's theorem¹⁰

$$\dot{\theta} = \frac{1}{2} \eta B_z \quad \text{where} \quad \eta = \left| \frac{e}{m} \right|. \quad (11)$$

Using (11), the expression for r derived from the Lagrangian is,

$$\ddot{r} + \frac{B_z^2 \eta^2}{4} r - \eta \frac{\partial V}{\partial r} = 0. \quad (12)$$

For an electron at the edge of the beam,

$$\frac{\partial V}{\partial r} = \frac{r_0^2 \rho}{2\epsilon r}$$

where r_0 is the beam radius at the entrance of the focusing structure and ρ is the volume charge density. Equation (12) now becomes,

$$\ddot{r} + \frac{B_z^2 \eta^2}{4} r - \frac{\eta r_0^2 \rho}{2\epsilon r} = 0. \quad (13)$$

It is convenient to make a change of variables. Let
 B_0 = peak value of the longitudinal magnetic field at the axis
 L = the magnet period (twice the distance between magnets)

$$\begin{aligned} \omega_\rho^2 &= \frac{\rho \eta}{\epsilon} & z &= u_0 t \\ \omega_L &= \frac{1}{2} \eta B_0 & \sigma &= \frac{r}{r_0} \\ \omega &= \frac{2\pi u_0}{L} \end{aligned}$$

where u_0 is the beam velocity which is assumed to be constant. Rewriting (13),

$$\frac{d^2 \sigma}{dt^2} + \left(\frac{B\eta}{2} \right)^2 \sigma - \frac{\omega_\rho^2}{2} \frac{1}{\sigma} = 0. \quad (14)$$

Using the value of B given in (6a)

$$\ddot{\sigma} + \frac{1}{2} \left(\frac{\omega_L}{\omega} \right)^2 (1 + \cos 2T) \sigma - \frac{1}{2} \left(\frac{\omega_\rho}{\omega} \right)^2 \frac{1}{\sigma} = 0$$

where $T = \omega t$ and $\ddot{\sigma} = d^2 \sigma / dT^2$.

For convenience let

$$\alpha = \frac{1}{2} \left(\frac{\omega_L}{\omega} \right)^2 \quad (15)$$

and

$$\beta = \frac{1}{2} \left(\frac{\omega_\rho}{\omega} \right)^2 \quad (16)$$

then

$$\ddot{\sigma} + \alpha(1 + \cos 2T)\sigma - \frac{\beta}{\sigma} = 0. \quad (17)$$

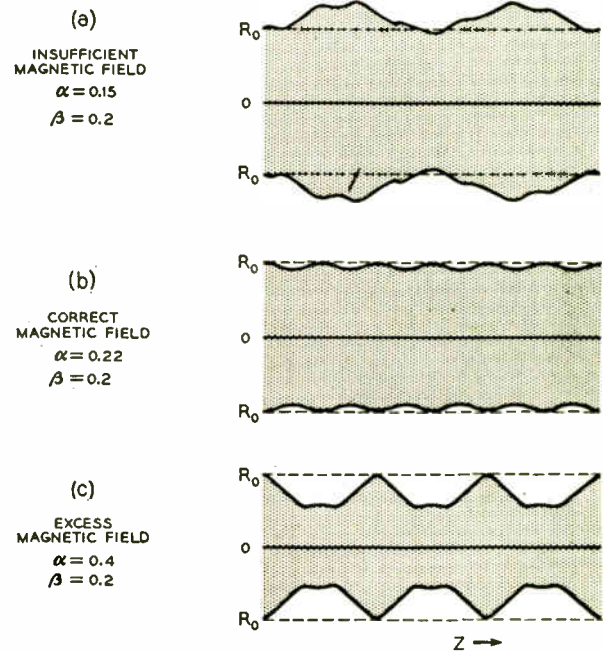

Fig. 13—Three typical analog-computer plots of beam radius as a function of distance, illustrating optimum flow conditions and deviations from this with an incorrect magnetic field. The small ripples in the three curves are associated with magnet spacing.

This nonlinear differential equation was solved with the aid of an analog computer for values of α and β of interest in the study of practical traveling-wave tubes. For practical reasons it was assumed that the electrons were injected with no radial velocity at the point $T=0$, i.e., at the point where the magnetic field was a maximum. In principle, this condition should be attainable by proper positioning of the electron gun.

⁹ J. C. Slater and N. H. Frank, "Introduction to Theoretical Physics," McGraw-Hill Book Co., New York, N. Y., p. 77; 1933.
¹⁰ Pierce, *loc. cit.*, p. 34.

As might be expected, for a given set of beam parameters "optimum" focusing was obtained when the rms magnetic field strength was equal to the corresponding Brillouin field. By "optimum" it is inferred that the perturbations in the beam radius were a minimum. A complete set of beam contour curves were obtained from the analog computer with various values of α (the magnetic field parameter) and β (the space-charge parameter). Fig. 13 is typical of the type of beam contours encountered with a change in the magnetic field parameter α and a fixed value of β . Curve (b) is the so-called optimum point since this represents a minimum of beam ripple. Such curves were obtained for a wide range of the space-charge parameter β and from these curves it was possible to construct a universal curve for optimum focusing conditions as shown in Fig. 14.

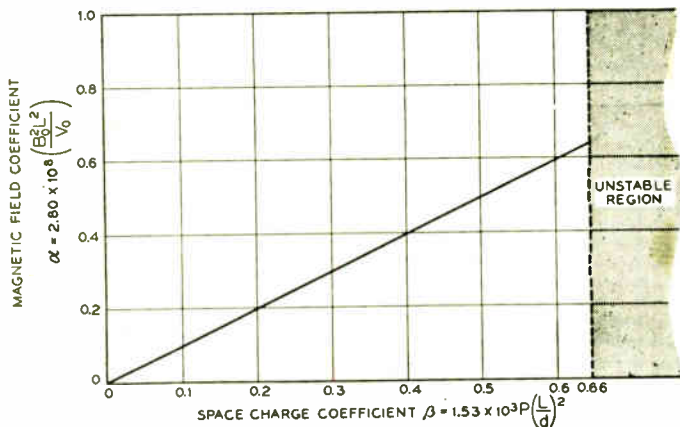

Fig. 14—Curve showing relation between beam parameters and magnetic field for the condition where the ripple on the beam boundary is a minimum.

In Fig. 14 it is evident optimum focusing occurs when

$$\alpha = \beta \tag{18}$$

or with (15) and (16) this can be written

$$I_0 = 1.45 \times 10^6 B_{rms}^2 a^2 V_0^{1/2} \tag{19}$$

where a = beam radius.

This will be recognized as the same relationship that exists with uniform field focusing in "Brillouin Flow" provided we associate the rms value of magnetic field in the periodic case with the dc field in the uniform field case and the average beam diameter in the periodic case with the beam diameter of the uniform case. Strictly speaking the required magnetic field applies only to the idealized beam that enters the structure with perfect parallel flow (no transverse velocities). In any physical system this is not the case and a higher magnetic field is required to hold the beam together within a prescribed radius.

In Fig. 15 the resultant minimum ripple is given for the optimum focusing conditions. This value will be exceeded in practice since a higher than optimum magnetic field is generally used. For high-percentage ripples it is

difficult to obtain good transmission due to the rather violent fluctuations of the beam radius which results in the intensification of the slight aberrations inherent in any physical system. Although Figs. 14 and 15 represent an ideal system which can only be approached in practice, they do give valuable information concerning the ultimate that can be achieved in periodic focusing, as well as the correct relationship between the various beam parameters. These curves can be interpreted in practical cases by multiplying the indicated magnetic field by some empirical factor to account for transverse velocities.

In addition to the conditions of optimum focusing (17) must be used to yield information on the nature of the stop bands. Thus it is necessary to determine the conditions under which (17) yields diverging solutions

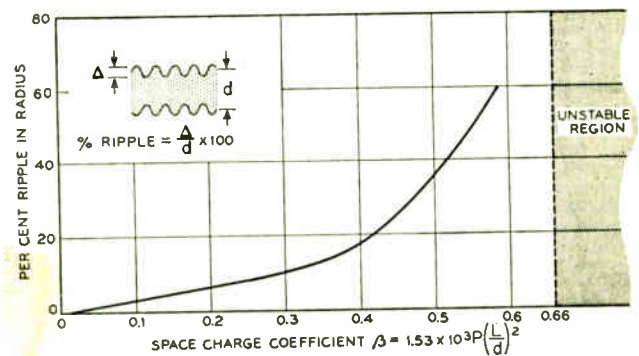

Fig. 15—Curve showing the minimum ripple which can be obtained on a beam which is focused with the optimum conditions shown in Fig. 15.

for σ . The equation can be simplified somewhat if it is noted that the last term on the left represents a diverging force. So, if the first two terms also give a diverging solution the entire solution of (17) must also diverge. By neglecting the space charge term (17) can be written

$$\ddot{\sigma} + \alpha(1 + \cos 2T)\sigma = 0. \tag{20}$$

This is a form of Mathieu's differential equation¹¹ with arbitrary constants specified, and is quite accurate for locating the position of the so-called stop bands. In (20) the nature of the solution for σ as a function of T (or z) depends upon the value of the constant α (which is always positive). For certain ranges of α , σ is periodic or quasi periodic and bounded while for other values of α , σ increases without limit thus indicating an unstable condition of electronic flow. These unstable regions can easily be found from the stability plot of (20)¹¹ given in Fig. 16, which applies to the general form of Mathieu's equation whereas the straight line on this plot applies to the particular form given in (17). As α is increased from zero along this straight line the solution for σ passes through successive regions of stability (pass band) and instability (stop band). It should be noted that this plot merely indicates the regions of α for which

¹¹ N. W. MacLachlan, "Theory and Application of Mathieu Functions," Oxford University Press, New York, N. Y.; 1947.

instability occurs since space charge has been ignored in obtaining this diagram. Therefore, the analog computer solutions are necessary to show that the stable regions indicated on Fig. 16 truly represent stable electron flow in the presence of space charge. Consequently, the Mathieu diagram only gives information concerning the location of the stop bands and is not intended as a guide for the conditions of good focusing.

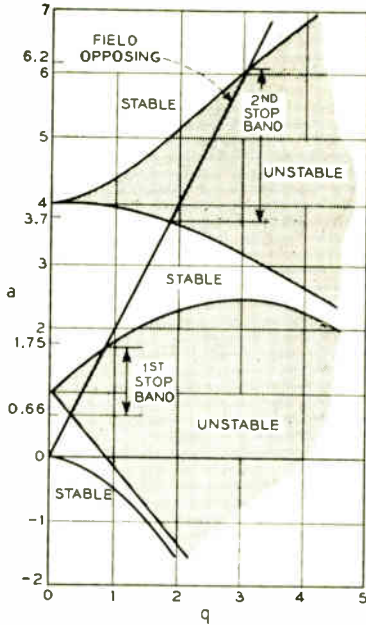

Fig. 16—Mathieu Stability Plot which gives the theoretical values of α (the magnetic field parameter) for the stop bands and pass bands. The general form of Mathieu's equation is,

$$\frac{d^2\sigma}{dT^2} + (a + 2q \cos 2T)\sigma = 0$$

and for the periodic structure $a = \alpha$, $q = \alpha/2$ yielding the straight line shown on the diagram.

As indicated in Fig. 16 instability and hence the beginning of the stop band occurs for

$$\alpha = 0.66$$

or with (15)

$$\frac{\eta B_0^2 L^2}{V_0} = 418. \tag{9}$$

The extent of the stop band together with the location of the second stop band is shown in Fig. 16. It is from this plot that the information for the theoretical stop bands is obtained for Figs. 4 and 6.

DESIGN CONSIDERATIONS

In considering the design of a periodic-structure it is instructive first to note the restrictions imposed by the stop-band phenomenon as expressed in (9):

$$\frac{\eta B_0^2 L^2}{V_0} < 418. \tag{9}$$

To achieve a balance between space-charge forces and the inward focusing force of the magnetic field, it is nec-

essary that (see Fig. 14)

$$\alpha = \beta. \tag{18}$$

Using the definition (15) and (16) for α and β , (18) becomes

$$\frac{\eta B_0^2 L^2}{V_0} = \frac{16}{\pi} \frac{1}{\epsilon \eta^{1/2}} P \left(\frac{L}{d} \right)^2.$$

Substituting (9) for the left-hand side of the above equation one obtains

$$P \left(\frac{L}{d} \right)^2 < 4.35 \times 10^{-4}. \tag{21}$$

This simple relationship gives the maximum value of $P(L/d)^2$ attainable with periodic system if it were possible to operate at the edge of the stop band. In practice, however, this value is less than that given in (21) because of two factors. First, for good focusing the operating voltage must be about 20 per cent in excess of the voltage at the stop band and secondly, it is necessary to use magnetic fields in excess of the Brillouin value by 50-100 per cent. These two factors combine to reduce the right-hand side of (21) to give

$$P \left(\frac{L}{d} \right)^2 \leq 10^{-4}. \tag{22}$$

This condition must be satisfied if good focusing is to be realized. Since perveance and beam diameter are probably the most fundamental constants of any beam such a relationship is very useful for determining the limitations of a given periodic structure.

If one considers the limiting value of L/d which can be realized in a practical structure then it is possible to describe a rough limit to the perveance that can be employed.

With axial symmetry the longitudinal magnetic field varies radially as

$$I_0 \left(\frac{2\pi r}{L} \right)$$

and, therefore, the ratio of the field at the inner diameter of the magnets to the field at the axis is given by Ratio = $I_0(\pi D/L)$ where D is the inner diameter of the magnets. In general D can be no less than three times the beam diameter. Let

$$D = 3d, \quad d = \text{beam diameter.}$$

Hence,

$$\text{Ratio} = I_0 \left(\frac{3\pi d}{L} \right).$$

Since there is a limit to the coercive force that can be achieved with permanent magnets, it is reasonable to ascribe an upper limit to the above ratio. Arbitrarily let

$$I_0 \left(\frac{3\pi d}{L} \right) \leq 3.$$

Consequently

$$\frac{3\pi d}{L} \leq 2.5$$

or

$$\left(\frac{L}{d}\right)^2 \geq 16.$$

Referring to (22) one can now write an approximate limit to the perveance that can be satisfactorily focused in a periodic structure.

$$P_{\max} \cong 6 \times 10^{-6}.$$

Fortunately, present-day beams typically employ perveances of the order of unity, which is well within the above practical limit.

CONCLUSION

This paper describes a system of permanent magnet focusing which realizes such a saving in weight and size that most beam-type vacuum tubes can be focused with a structure weighing but a few pounds. This is to be compared with previous methods which required magnets which weighed more than 40 pounds. Also, the new system makes practical the design of much longer beam-type tubes than could previously be considered because of the cumbersome focusing structure required.

The limits of practicability of this system include beam perveances in excess of what is commonly used today with magnetic field strengths which are realizable with commercially available permanent magnet material. Although there is a stop-band phenomenon to consider, design procedures have been established which determine a suitable structure once the perveance and beam diameter are specified.

The experimental evidence presented shows very good agreement with the analytical results, and in addition demonstrates the feasibility of obtaining satisfactory focusing (>99 per cent transmission) with practical structures. It is felt that one of the prime objections to long beam-type amplifiers, namely the bulky magnets or power consuming solenoids, has been eliminated with the successful demonstration of permanent magnet periodic focusing.

ACKNOWLEDGMENT

The authors gratefully acknowledge the many cogent suggestions given by C. C. Cutler and R. Kompfner, and their encouragement throughout the course of this work. Also, the fine constructive efforts of L. E. Cheesman, N. E. Cram, and P. Hannes are greatly appreciated.

APPENDIX A

As approximations to the fields produced by a uniform magnet and by a periodic magnetic structure, consider Fig. 17. Fig. 17(a) shows a segment of length L

(period = $2L$) of an infinitely long sinusoidal distribution of magnetic field. This, it is assumed, is approximately the distribution of flux from a bar magnet of effective length L at a radial distance from the structure of $r = Na$. Fig. 17(b) shows a segment of length L from a sinusoidal distribution of field where the periodicity has been increased by N , i.e., $Nx = L$. This is approximately the magnetic field distribution from a periodic magnetic structure at a distance $r = a$. It is assumed that the two fields are derived from magnets or lenses having similar geometries, simply differing by a scale factor N . Hence the field in Fig. 17(a) at a distance $r = Na$ will equal that of Fig. 17(b) at a distance $r = a$.

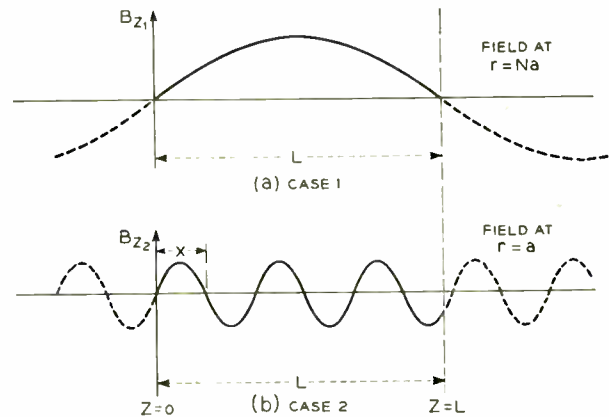

Fig. 17—Approximate form of magnetic fields for (a) a long bar magnet of length L , and (b) for a periodic magnetic structure of length L and periodicity N .

Since in a region of no current B_z in cylindrical coordinates is a solution of Laplace's equation we know that the fields for the two cases may be written

$$B_{z1}(r, z) = C_1 \frac{\pi}{L} K_0\left(\frac{\pi r}{L}\right) \sin \frac{\pi z}{L} \text{ for case 1, and}$$

$$B_{z2}(r, z) = C_2 \frac{\pi}{x} K_0\left(\frac{\pi r}{x}\right) \sin \frac{\pi z}{x} \text{ for case 2.}$$

From the above assumptions then

$$\begin{aligned} B_{z1}(Na, L/2) &= C_1 \frac{\pi}{L} K_0\left(\frac{\pi Na}{L}\right) = B_{z2}\left(a, \frac{x}{2}\right) \\ &= C_2 \frac{\pi}{x} K_0\left(\frac{\pi a}{x}\right) \end{aligned}$$

or

$$\frac{C_1}{L} = \frac{C_2}{x}.$$

We are interested in the stored magnetic energy which in the above two cases leads to the following expressions. In case 1,

$$W_1 = \int_{Na}^{\infty} B_{z1}^2 dA$$

$$= \int_{Na}^{\infty} B_{z1}^2 r dr \quad \text{where } W_1 \text{ is proportional to energy}$$

$$= C_1^2 \int_{\pi(Na/L)}^{\infty} \nu K_0^2(\nu) d\nu$$

and similarly for case 2,

$$W_2 = C_2^2 \int_{\pi a/z}^{\infty} \nu K_0^2(\nu) d\nu.$$

Since $L = Nx$ the two integrals are equal and thus

$$\frac{W_2}{W_1} = \frac{C_2^2}{C_1^2} = \frac{1}{N^2}.$$

Thus the external stored energy in the periodic structure is $1/N^2$ times that of the uniform field magnet for this idealized case.

APPENDIX B

Derivation of the Magnetic Field at the Center of a Periodic Focusing Structure

In deriving the dynamic equations describing the motion of electrons in a beam focused with a periodic magnetic structure, we assume the magnetic field is constant across the beam diameter and is of the form

$$B_z = B_0 \cos \frac{2\pi z}{L}.$$

In actual structures the magnetic field does have a variation with r and also contains higher harmonics as shown in the following derivation. Fig. 18 shows a plot of the field and a sketch of the structure from which the field is derived.

In a current-free region B_z satisfies Laplace's equation. If cylindrical co-ordinates are used, this leads to solutions of the form:

$$B(z, r) = \sum_1^{\infty} C_n I_0 \left(\frac{2n\pi r}{L} \right) \cos \frac{2n\pi z}{L}.$$

Evaluating C_n , we get,

$$C_n = \frac{4}{\delta I_0 \left(\frac{2n\pi R}{L} \right)} \int_0^{\delta/2} B_{gap} \cos \frac{2n\pi z}{L} dz$$

where R is the radius of the whole through the pole piece.

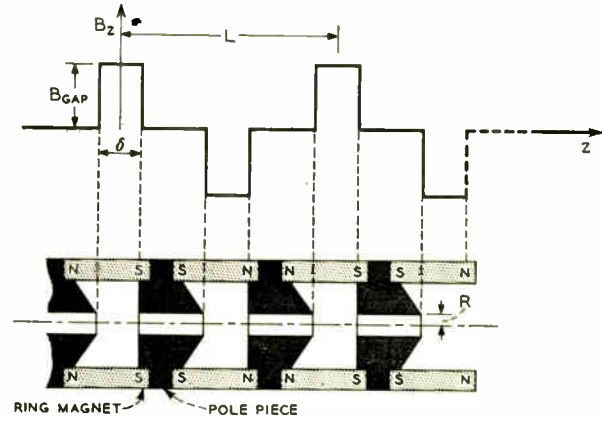

Fig. 18—Magnetic field strength at the edge of the pole pieces for a periodic magnetic structure.

$$C_n = \frac{4B_{gap}}{I_0 \left(\frac{2n\pi R}{L} \right)} \frac{\sin \frac{n\pi\delta}{L}}{n\pi} \quad n = 1, 3, 5, \dots$$

In the present case $R = 0.160$ inch, $L = 1.000$ inch, and $\delta = 0.150$ inch and the expression for the magnetic field on the axis of the structure is

$$B(z, 0) = B_{gap} \left[.456 \cos \frac{2\pi z}{L} + .0711 \cos \frac{6\pi z}{L} + .0066 \cos \frac{10\pi z}{L} + \dots \right].$$

Antenna and Receiver Measurements by Solar and Cosmic Noise*

JULES AARONS†, ASSOCIATE, IRE

Summary—Utilizing the most intense of the several hundred celestial sources of radio frequency energy, and known data about the effective diameter of the sun at various ranges of radio frequencies, a technique for plotting the directional characteristics of large antennas is outlined. Over-all system sensitivities (receiver, antenna, and transmission line) are checked by using values already obtained for sky temperatures. The general receiver characteristics necessary for such measurements are outlined. Patterns of antennas are illustrated and their analysis evaluated.

* Decimal classification: R221×R261×R113.4. Original manuscript received by the IRE, July 6, 1953; revised manuscript received, December 4, 1953. Presented at the 1953 IRE National Convention, New York, N. Y.

† Air Force Cambridge Research Center, Cambridge, Mass.

BACKGROUND

Basic research in astronomy, within the past five years, has used two new tools extensively, the low-noise stable radio receiver and the highly directive antenna. Both the sun and the cosmic noise sources have been explored extensively with these tools.

The greatest amount of energy, as recorded by observations, from both of these sources is in the 18-mc to 300-mc region. The cosmic sources have been explored almost wholly in this frequency region. The sun maintains its irregular or disturbed component basically

in the low frequencies and has a rather quiet radiation at the microwave end of the radio spectrum. Receiver equipment designed to detect these sources is exceedingly stable.

Several workers in the field now use previously established facts about the sun and the cosmic sources to calibrate their antennas. For other antennas which have large effective areas, the cosmic and solar sources might prove to be useful. These sources are never, of course, in the near field; they can be located precisely at all times using astronomical tables; they present a means for checking the over-all system sensitivity over long periods of time in case of deterioration of equipment. This technique of sensitivity calibration would aid in maintaining similar sets of identical equipment at constant levels by providing a "primary" noise-source standard

RECEIVER PRINCIPLES USED IN THE DESIGN OF RADIO TELESCOPES

For these measurements three basic factors are important.

1. The most vital consideration in over-all design of the receiver is its stability. Australian scientists¹ have designed 100-mc equipment which achieves stability of one part in 10,000 for the B plus voltage, and one part in 6,000 for the filament voltage. They, therefore, were enabled to obtain changes in sky temperatures of 0.3 degrees K. After detection bucking voltage is set up to rid the receiver of the steady-state noise. A milliammeter or microammeter records the signal.

2. In addition to constant supply voltages and dc-filament voltage (in some cases), these low-noise receiving systems use long time constants in their recorders.

The minimum signal which can be detected is proportional to the square root of the bandwidth-time constant product.

$$\frac{P_{\min}}{P_n} = \frac{1}{\sqrt{BC}} \quad (1)$$

P_{\min} = minimum detectable signal power

P_n = power generated in the receiver and delivered to the receiver

B = bandwidth in cycles per second

C = time constant.

From the analysis suggested by Dicke,² the output is the sum of a large number of successive random pulses, each of average duration $1/B$. In a time interval ΔT (the time constant of the output system) $B\Delta T$ pulses are received. Solar noise bursts have been of the order of one-half second or longer, and time constants have been maintained in that range. Bandwidths have varied, although in many cases bandwidths have been below radar or television bandwidth requirements.

3. Atmospheric noise, ignition noise, etc., in the vicinity of the antennas can be an important factor.

¹ C. W. Allen and C. S. Gum, "Survey of galactic radio-noise at 200 mc," *Aus. Jour. Sci. Res. A.*, vol. 3, p. 224; 1950.

² R. H. Dicke, "The measurement of thermal radiation at microwave frequencies," *Rev. Sci. Inst.*, vol. 17, p. 268; 1946.

THE SOURCES

The Sun

The sun is a variable source of radiation emitting on top of its normal "quiet" level signal an enhanced base or long-term level plus shortlived bursts and outbursts.

Angular width and general activity vary on different frequencies (Fig. 1). The width of the photosphere, the optical width of 31 minutes, 59.3 seconds, approaches the radio-frequency width at 1 cm. However, at 90 per cent of the emergent intensity of its central ray at 60 mc the sun appears as a source of 47 minutes. The exact details of the width are still in doubt. New data taken by P. A. O'Brien at the Cavendish Laboratory in Cambridge, England would tend to increase the width considerably (Mon. Not. R.A.S. in press).

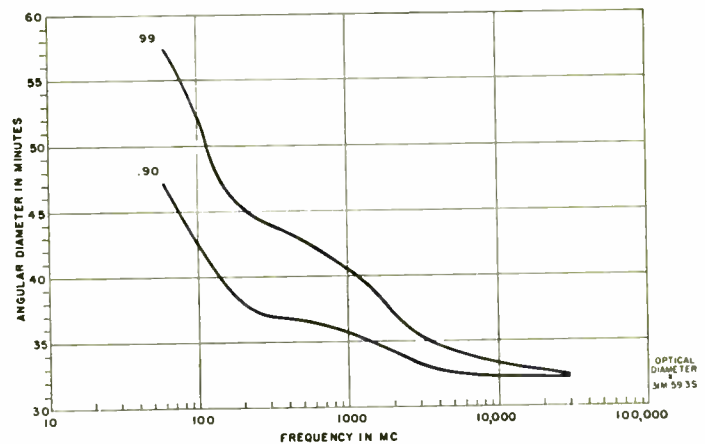

Fig. 1—Angular diameter of the sun at radio frequencies (Smerd).³

The general activity at the low end of the radio frequency spectrum is much greater than in the microwave region. For the former, during a disturbed day, several hundred bursts may occur within the space of one hour at 200 mc.

At centimeter wavelengths the picture is different. "Sudden increases of radiation at 3.18 cm caused by disturbed conditions in the sun, were found to be rare."⁴

These observations make the measurements outlined in this paper more feasible for the sun in the microwave range. At the low activity portion of the sunspot cycle measurements in both ranges are quite possible.

Cosmic Noise

Much exploratory work has been done in the radio frequency band of 18 mc to 400 mc in cosmic noise sources. At 1,200 mc, Cygnus A, the most "intense" point source is rather diffuse.⁵ At 3,000 mc no point sources have been located. Therefore, cosmic noise is feasible only for radio-frequency measurements at the low end of the spectrum.

³ S. F. Smerd, "Radio frequency radiation from the quiet sun," *Aus. Jour. Sci. Res. A.*, vol. 3, p. 34; 1950.

⁴ H. C. Minnett and N. R. Labrum, "Solar radiation at a wavelength of 3.18 cm," *Aus. Jour. Sci. Res. A.*, vol. 3, p. 60; 1950.

⁵ J. H. Piddington and H. C. Minnett, "Radio frequency radiation from the constellation of Cygnus," *Aus. Jour. Sci. Res. A.*, vol. 5, p. 17; 1952.

Several hundred of these sources of radio-frequency energy have been located. The most intense ones, the sources suitable for our measurements, range from one minute to thirty minutes of arc in source width. At a frequency of 100 mc the intensity varies downward from 128×10^{-24} watts/cycles/second/steradian.⁶

A few of the sources, viewed at a low angle of elevation above the medium have fluctuating components due to ionospheric twinkling. One of these, Cyngus A, had maximum variations of about 10 per cent at 200 mc.

ANTENNA PATTERNS' MEASUREMENT TECHNIQUE

Calculation of Beam Angle

Taking measurements with this technique must be done with the aid of radio astronomy celestial maps. At meter wavelengths the cosmic sources cannot be used if the milky way is in the background. The same holds true for the sun. Those sources which are near the galactic center will seem to stretch out the antenna pattern. Since we now have a gaussian distribution to contend with, the corrected antenna angle is

$$\theta_t = \sqrt{\theta_m^2 - \theta_s^2} \quad (2)$$

θ_t = the true antenna angle

θ_m = the measured antenna angle

θ_s = the gaussian curve of the contours through which the antenna is sweeping.

For the case of the point source which is sharp and above the intensity of neighboring contours, the particular curve must be considered in subtracting source size from measured size in order to obtain the true antenna angle. In the case of the sun, the intensity may be considered rectangular for a good approximation at the shorter wavelengths but only a fair approximation at the longer wavelengths. The sides are sloping, but except for an element of brightening at the edges (at microwave frequencies) the top is flat. In this case, then, the angle subtended by the sun may be subtracted from the measured antenna angle and the true angle obtained.

If the stars are considered as points on the inner surface of a rotating sphere, there lies within, a stationary globe, the earth. The axes of the two spheres are inclined towards one another; they are not parallel. This failure to "line up" will produce an incorrect pattern for an antenna which is fixed in azimuth and the sources allowed to sweep across it. These patterns can be measured reasonably well if the beam angle is small and the source, therefore, takes only a small amount of time to cross the antenna pattern.

After taking the pattern, the correction factor of sky contours must be applied. Isothermal lines at various frequencies have roughly the same shape. At 18.3 mc the contours are similar to 100 mc.⁷ A field technique

which might be put to use is to make measurements on a particular antenna under laboratory-controlled conditions, reducing losses to a minimum, and achieving an adequate test pattern. If an antenna test pattern is then obtained of the sun or a cosmic source, a standard can be set up for pattern and sensitivity comparison.

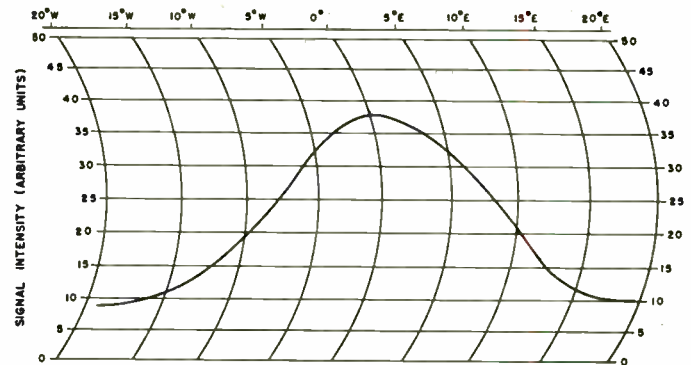

Fig. 2—Sweep across sun on October 16, 1952; main lobe 200-mc antenna.

Measurement at Cornell University

Examples of the measurements of antenna beam angles are simple to analyze for a first approximation to the pattern. Fig. 2 illustrates a swing of the antenna across the sun on October 16, 1952, on 200 mc, by the Cornell University solar noise equipment.⁸ A peak value of 37.5 units was subtracted from a background value of 7 units. Therefore, the half-power points are 18 degrees apart. If this figure is reduced by the value of the width of the source (38 minutes at 90 per cent down from the emergent intensity) the resultant value is 17 degrees 22 minutes, assuming the solar source is a rectangle.

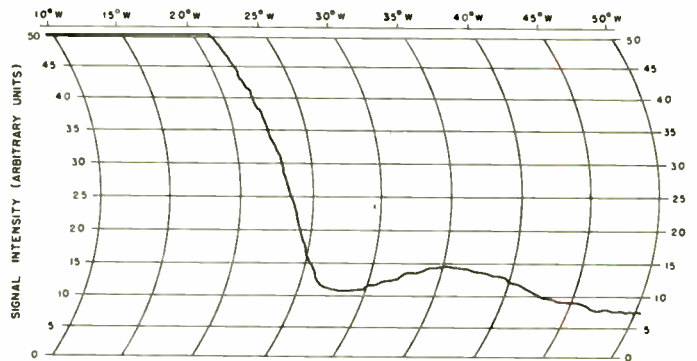

Fig. 3—Sweep across sun on October 16, 1952; side lobe 200-mc antenna.

Fig. 3 illustrates measurements taken of the side lobe patterns. The technique used was to increase the gain of the equipment and concentrate on the side lobe.

Patterns can be taken with an antenna fixed in azimuth. In one minute of time, 15 minutes of arc times the cos of the declination is traversed.

⁶ G. J. Stanley and O. B. Slee, "Galactic radiation at radio frequencies," *Aus. Jour. Sci. Res. A.*, vol. 3, p. 234; 1950.

⁷ C. A. Shain, "Galactic radiation at 18.3 mc," *Aus. Jour. Sci. Res. A.*, vol. 4, p. 258; 1951.

⁸ All measurements used in this paper were made by the Cornell University Radio Astronomy Laboratory. S. M. Colbert made the measurements under the general supervision of Dr. C. Burrows.

SENSITIVITY

Over-all Sensitivity Measurements

A possibility exists for measuring changes in the sensitivity of the receiving equipment from the antenna to the recorder. Since the essential criterion of the proposed system will rely on its ability to distinguish between noise levels, let us first consider some of the noise equations.

The available noise from a resistor⁹ is:

$$P_r = \frac{e_n^2}{4R} = KT_a B \quad (3)$$

P_r = available noise power in watts

e_n = RMS voltage

K = Boltzmann's constant (1.37×10^{-23} watt-sec/degree K)

T_a = "ambient" temperature in degrees Kelvin usually taken at Friis' standard of 290 degrees K

$KT_a \approx 4 \times 10^{-21}$ watt-seconds.

The noise figure (F) of a receiver under test is the ratio of the actual noise power output to the noise power output of an ideal network.

The component of the noise figure due to internally generated noise (all noise other than the input resistor noise) is equal to $F - 1$.

In order to detect a small amount of energy being radiated from external sources, the power absorbed by the antenna and delivered to the receiver must be of the same magnitude or larger than the fluctuations in the internally generated noise of the receiver. If the internally generated noise were perfectly steady in its amplitude, it would be theoretically possible to detect any increase caused by external power being absorbed. The variable component of the noise is a function of the bandwidth and the time constant of the circuit, provided the supplies are stable and no outside interference takes place.

Equation (1) shows that for a bandwidth of one megacycle and a time constant of one second in the recording apparatus it is theoretically possible to detect signals of the order of 1/1,000 of the internal noise.

$$P_{\min} = \frac{KT_a B(F - 1)}{\sqrt{BC}} \quad (4)$$

where $KT_a B(F - 1)$ or P_n is the power generated in the receiver and delivered to the receiver.

The absorption of energy by the antenna for the case of the homogeneous areas of emission (Θ) energy source $> \Theta$ antenna is:

$$P_{\text{abs}} = KT_c B. \quad (5)$$

If the antenna absorbs just enough energy from the radio noise source so that a small signal can be seen above

the theoretical noise minimum of the receiver P_{\min} can be set equal to P_{abs} . Eliminating the constants we obtain

$$T_c = \frac{T_a(F - 1)}{\sqrt{BC}}. \quad (6)$$

P_{abs} = power in watts absorbed by the radiation resistance of the antenna and delivered to the receiver

T_c = sky temperature.

The measurement of $P_{\text{abs min}}$ (the minimum amount of power which the antenna must absorb before the power output rises above the internal noise power), and with the measurement of the noise figure, the bandwidth and the time constant, a new criterion for receiver evaluation is available, i.e., that of stability.

The ratio of measured power absorbed (with a perceptible change of level noted) to theoretical power (P_{\min}) yields the stability factor M . A value of one, just as in the case of the noise figure, is obtained when the unit is perfectly stable.

$$\frac{T_{cm}}{T_{ct}} = M. \quad (7)$$

T_{cm} is the measured temperature of the homogeneous sky source which yields a level which can be distinguished above the fluctuations of receiver noise. By setting P_{abs} equal to P_{\min} in (6) we had actually obtained:

$$T_{ct} = \frac{T_a(F - 1)}{\sqrt{BC}} \quad (8)$$

Where T_{ct} is the theoretical temperature of the antenna plus the receiver.

A change of the stability factor M as evidenced by inability to detect certain radiating areas of the sky will be caused by an increase in F , a change in the system stability due to power supply fluctuations (assuming bandwidth and time constant are fixed), or a deterioration in the antenna system (transmission line, mismatching, etc.). Antenna-gain considerations do not enter into the equation.

In the case of receiving systems dependent on comparison techniques, the stability can be an important consideration. A simple means of detecting increase in the noise factor or other parameters of the receiver is the technique of pointing the antenna at the sky.

As a routine check on the stability factor (M), one technique is to attempt to distinguish between two sets of contours or two areas. Instead of using the absolute power from one area, the difference in power between two areas with a temperature difference of ΔT can be utilized. The receiver should be able to distinguish between two areas which have

$$\Delta T_{cm} = \Delta T_{ct} M. \quad (9)$$

⁹ H. T. Friis, "Noise figures of radio receivers," Proc. I.R.E., vol. 32, p. 419; July, 1944.

Fig. 4 represents Cornell University's 200-mc stabilization data which is taken daily. Here a reference resistor at 290 degrees represents a zero point. The levels

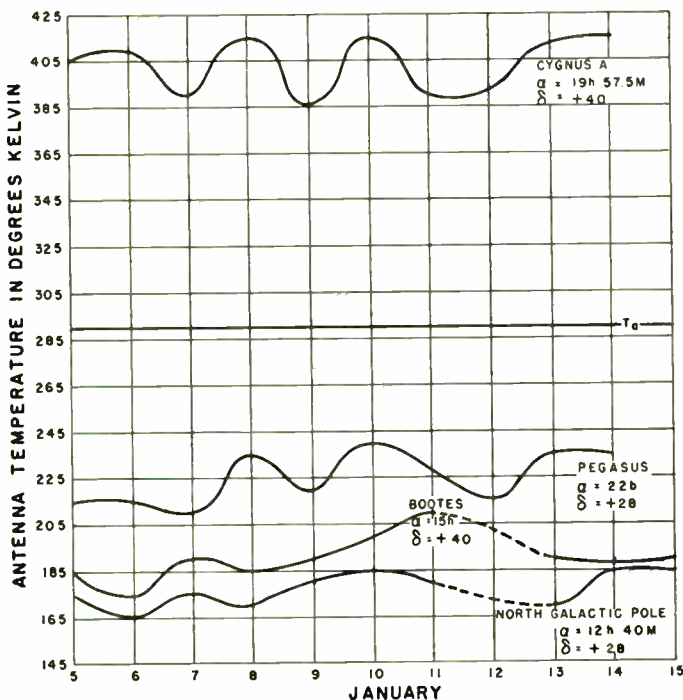

Fig. 4—Stability measurements by means of sky noise January 5-15, 1953.

In one radio astronomy project designed for somewhat different purposes, an M of 2 was obtained. For normally stabilized radio receivers it is estimated that an M of 100 would result.

⊖ Antenna > ⊕ Energy Sources

Summing the Rayleigh Jeans radiation law into total emissive power and converting the equation into frequency form, the power absorbed by an antenna with the energy source smaller than the beam angle is¹⁰

$$P_{abs} = \frac{G_0 K \Omega_s T_s B}{4\pi} \quad (10)$$

Ω_s = solid angle subtended by the optical disk of the sun

T_s = the equivalent black body temperature of the sun in degrees Kelvin

G = antenna gain in the maximum direction.

Fig. 5 graphs the value of $K\Omega_s T_s$ for the sun as a function of frequency.

⊕ Energy Source > ⊖ Antenna

If the entire area of the antenna's main lobe is homogeneously filled with radiation, directional characteristics of the antenna do not enter into the calculations.

$$P_{abs} = KTB.$$

For a large antenna, the measurements involving por-

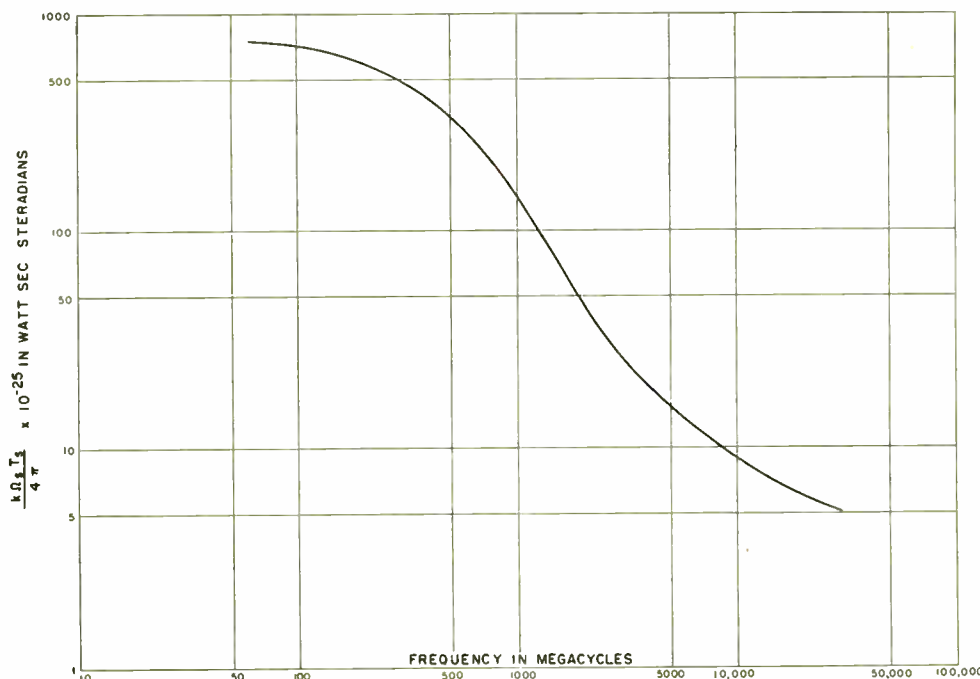

Fig. 5—Effective solar temperature as a function of frequency (Hagen).¹¹

above and below this are for portions of the sky centered at the location given. Utilizing (8),

$$F = 5.9$$

$$B = 5 \text{ mc}$$

$$C = \frac{1}{2} \text{ second}$$

a ΔT_{et} of 0.9 degrees K is obtained.

tions of the sky which emit a uniform signal level can be made to obtain a field intensity in microvolts per

¹⁰ H. C. Van de Hulst, "A Course in Radio Astronomy," Leiden Observatory, Holland; 1951.

¹¹ J. P. Hagen, "Temperature gradient in the sun's atmosphere measured at radio frequencies," *Astron. Jour.*, vol. 113, p. 547; 1951.

meter. References 1 and 7 contain maps plotted for various frequency regions.

No contours are available for the microwave regions due to the low-temperature differences involved. For the galaxy, the effective temperature varies approximately as λ^2 . At 4.7 meters, Hey, Parsons and Phillips (1948) obtained a maximum of 18,000 degrees K.¹² For the same region, 30 degrees K was obtained from Reber's data on 60 cm.

CONCLUSION

The possibilities for the use of this technique lie as a field tool for checking patterns and sensitivity. The in-

¹² J. S. Hey, S. S. Parsons, and J. W. Phillips, "An investigation of galactic radiation in the radio spectrum," *Proc. Royal Society*, vol. 192, p. 425; 1948.

accuracies involved in evaluating background radiation, contours, and solar energy distribution are such that a very accurate laboratory field set-up would be a better tool. However, for a check on field instruments as to their noise level, stability, antenna pattern, and terrain fluctuations, the technique can be of use.

ACKNOWLEDGMENT

I would like to thank S. M. Colbert of the Cornell University Radio Astronomy Laboratory for his assistance in obtaining the data for this report. I would also like to thank Prof. Charles Burrows for his co-operation with the work. Miss Martha Henissart, of Wentworth Institute, assisted in preparing the graphs and the data and in many of the problems of interpretation.

IRE Standards on American Recommended Practice for Volume Measurements of Electrical Speech and Program Waves, 1953*

COMMITTEE PERSONNEL

Standards Committee, 1953-1954

A. G. JENSEN, *Chairman*
M. W. BALDWIN, JR., *Vice Chairman*
L. G. CUMMING, *Vice Chairman*
E. WEBER, *Vice Chairman*

K. E. Anspach	F. T. Budelman	J. L. Dalke	P. J. Herbst	W. M. Pease	R. F. Shea
J. Avins	H. F. Burkhard	A. W. Friend	J. G. Kreer, Jr.	W. J. Poch	R. E. Shelby
R. R. Batcher	C. A. Cady	F. J. Gaffney	E. A. Laport	D. C. Ports	N. Smith
W. R. Bennett	P. S. Carter	W. D. Goodale, Jr.	W. P. Mason	P. C. Sandretto	W. G. Tuller
J. G. Brainerd	A. G. Clavier	R. A. Hackbusch	G. D. O'Neill	R. Serrell	

Measurements Co-ordinator

E. WEBER

Audio Techniques Committee 1950-1953

C. A. CADY, *Chairman*, 50-53
R. A. MILLER, *Past Chairman*, 50-53¹
D. E. MAXWELL, *Vice Chairman*, 50-53

H. W. Augustadt, 50-53	D. H. Castle, 50-53	H. D. Harris, 50-52	F. L. Hopper, 50-53	R. B. Monroe, 50-52
W. L. Black, 50-53	W. W. Dean, 50-52	J. K. Hilliard, 50-53	I. M. Kerney, 52-53	W. E. Stewart, 50-53
H. Burris-Meyer, 50-52				

¹ Chairman, 50-52.

Subcommittee on Revision of ASA C16.5-1942

C. A. CADY, *Chairman*, 50-52
L. B. Cooke, 50-52 W. W. Dean, 50-52 J. W. Miller, 50-52 R. B. Monroe, 50-52

1. GENERAL

These standards apply to the methods of and a device for measuring the dynamic magnitude of complex audio-frequency electrical waves such as occur in speech and music.

The measurement of the complex and nonperiodic waves encountered in electrical communication cannot be expressed in simple fashion in the ordinary electrical terms of current, voltage, and power. The concept of "volume" furnishes a practical method of great utility

* Reprints of this Standard, 53 IRE 3. S2, may be purchased while available from The Institute of Radio Engineers, 1 East 79 Street, New York 21, N. Y., at \$0.50 per copy. A 20 per cent discount will be allowed for 100 copies or more mailed to one address.

to the communications engineer for assigning a numerical value to the magnitude of electrical speech and program waves.

Volumes are read by noting the more extreme meter deflections of a device known as a volume indicator. Since the response of the meter of such an instrument to the rapidly varying waves is greatly dependent upon its dynamic characteristics, a standard for volume measurements must, therefore, include a specification of these characteristics.

This standard uses the term "vu" to express volume in terms of vu above or below a specified reference level, defined herein.

2. DEFINITIONS

The following terms apply specifically to the standard volume indicator and its use.

2.1 Volume. The magnitude of a complex audio-frequency wave in an electrical circuit as measured on a standard volume indicator.

2.2 Standard Volume Indicator. A device for the indication of volume, and having the characteristics described in Section 4.

Note—A standard volume indicator consists of at least two parts:

- (a) A meter.
- (b) An attenuator (adjustable loss) or pad (fixed loss).

2.3 vu (pronounced "vee-you" and customarily written with lower case letters). A quantitative expression for volume in an electric circuit.

Note 1—The volume in vu is numerically equal to the number of db which expresses the ratio of the magnitude of the waves to the magnitude of reference volume.

Note 2—The term vu should not be used to express results of measurements of complex waves made with devices having characteristics differing from those of the standard volume indicator.

2.4 Reference Volume. The level which gives a reading of 0 vu on a standard volume indicator.

Note 1—The methods of reading and calibration are described in Section 4.

Note 2—The "reading of 0 vu" is the algebraic sum of the meter and attenuator readings on the standard volume indicator.

2.5 Reference Deflection. The deflection to the meter-scale point marked 0 vu, 100, or both.

Note 1—This is the deflection at which the meter should be used.

3. STANDARD VOLUME INDICATOR

Volume is measured by means of a volume indicator. This device must conform to the following specifications and must be used in the manner described below.

3.1 Circuit Impedance. The magnitude of the circuit impedance across which the volume indicator is in-

tended to be connected is designated herein as "R" ohms, which is the resistive impedance used for calibration. When so used, the requirements of Sections 4.2 and 4.5 must be met.

Note 1—The impedance presented to the volume indicator by a circuit impedance of "R" ohms is nominally $R/2$ ohms; resulting from the parallel combination of the "R" ohm source and the "R" ohm load.

3.2 Dynamic Characteristics. If a sinusoidal voltage between 35 and 10,000 cycles per second, of such amplitude as to give reference deflection under steady-state conditions is suddenly applied, the meter pointer shall reach 99 per cent of reference deflection in 0.3 second, ± 10 per cent, and shall then overswing reference deflection by at least 1.0 per cent and not more than 1.5 per cent. The time required for the meter pointer to reach its position of rest on the removal of the sinusoidal voltage shall not be greatly different from the time of response.

3.3 Response-Versus-Frequency Characteristic. The response of the volume indicator shall not depart from that at 1,000 cycles per second by more than 0.2 decibel between 35 and 10,000 cycles per second nor more than 0.5 decibel between 25 and 16,000 cycles per second.

3.4 Response to Complex Waves. The response to complex waves of such amplitude as to give reference deflection when read, as described in 4.9, shall be that equivalent to the response with a direct-current meter and a rectifier, the exponent of whose characteristic is 1.2 ± 0.2 .

3.5 Reversibility. The response when measuring unsymmetrical waves must be independent of the poling of the volume indicator. Such a characteristic may be obtained by the use of a direct-current meter in conjunction with a full-wave rectifier.

3.6 Graduation of Meter Scale. The point of reference deflection shall be definitely indicated in some suitable manner. The remainder of the scale shall be graduated in vu above and below reference deflection. (See also 4.4)

3.7 Attenuator Marking. The attenuator shall be marked in vu.

3.8 Calibration. A correctly calibrated volume indicator with its attenuator set at 0 vu will give reference deflection when connected to a source of a sinusoidal voltage adjusted to develop 1 milliwatt in a resistance of R ohms, or with the attenuator set at n vu when the calibrating voltage is adjusted to develop a power n decibels above 1 milliwatt.

3.9 Method of Reading Volume Indicator. The reading is determined by the greatest deflections occurring in a period of about a minute for program waves, or a shorter period (e.g., 5 to 10 seconds) for message telephone speech waves, excluding not more than one or

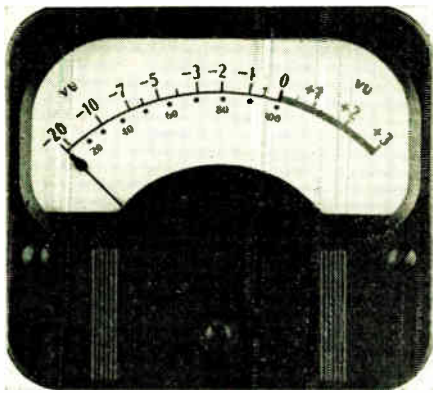

Fig. 1

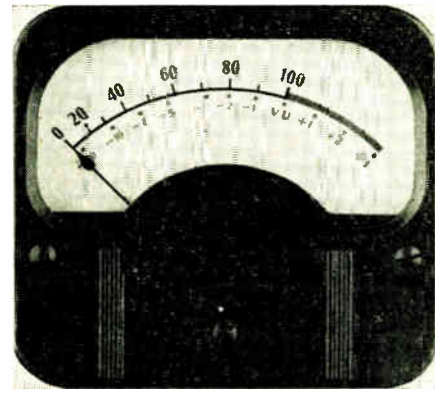

Fig. 2

two occasional deflections of unusual amplitude. The volume indicator is usually connected across the circuit at a point where the impedance is R ohms and the attenuator is adjusted until the deflections, read as described above, just reach the scale point corresponding to reference deflection. The volume in vu is determined by the markings on the attenuator at the setting thus obtained. If for any reason the deflections reach some other scale point than that corresponding to reference deflection, the volume is given by the algebraic addition of the attenuator setting and the actual deflection as read on the meter scale. When volume delivered to an impedance differing from R ohms is to be measured, the volume indicated must be corrected to correspond to this difference. Correction (to be added algebraically) in $\text{vu} = 10 \log_{10} R/|Z|$, where $|Z|$ = magnitude of actual impedance.

4. GOOD ENGINEERING PRACTICE

The following items are not fundamental to this standard but are matters of good engineering practice.

4.1 Impedance. The preferred circuit impedances (R ohms) for calibration of the instrument are 600 and 150 ohms. The volume indicator is normally used as a bridging instrument and when so used its impedance must be sufficiently high so as not to influence unduly the waves in the circuit with which it is used. It is good practice to make the value of impedance not less than $12.5 R$ ohms, for use on an R -ohm circuit. This corresponds to an insertion loss of approximately 0.4 decibel.

4.2 Harmonic Distortion. The root-mean-square value of the harmonic distortion produced when the volume

indicator is bridged across a resistive circuit impedance through which a sinusoidal wave between 25 and 8,000 cycles per second is being transmitted should not exceed 0.2 per cent of the fundamental.

4.3 Ability to Withstand Overload. The instrument should withstand without injury or effect on calibration, a momentary overload of ten times the voltage corresponding to reference deflection, and a continuous overload of five times that voltage, because of the great variation in amplitude which this indicator may encounter.

4.4 Scale. The point of reference deflection should be located within a sector between $\frac{2}{3}$ and $\frac{3}{4}$ of full scale. In addition to the vu scale, a 0-to-100 scale proportioned to voltage should be provided. Samples of the two types of scales in general use are shown in Figs. 1 and 2. The color of the scale card, expressed according to the Munsell system of color identification, should be 2.93Y(9.18/4.61). No markings other than those associated with the scale should be visible on the scale plate when the indicating meter is viewed directly from the front.

4.5 Marking. The nominal input impedance of the device and the impedance for which it is calibrated should be marked on the panel of the volume indicator assembly. This designation may be omitted when the volume indicator is a bridging device calibrated for 600 ohms. The marking of the meter scale does not uniquely determine the calibration. For example, the meter sensitivity might be such that 0 vu on the meter scale corresponds to a volume of +4 vu. In this case, the zero-loss position of the attenuator would be marked +4 vu.

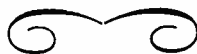

A Gas-Discharge Noise Source for Eight-Millimeter Waves*

T. J. BRIDGES†

Summary—A noise source of the gas-discharge type for use at eight millimeters wavelength is described. Noise temperatures of 19,300 degrees K (18.2 db above room temperature) using neon, and 11,500 degrees K (15.9 db) using argon, have been measured by means of a microwave radiometer. These figures agree well with values calculated from gas-discharge theory.

INTRODUCTION

NOISE SOURCES of the gas discharge type have been described for use at cm wavelengths.^{1,2} It is now established²⁻⁴ that the noise radiated by such sources is associated with the high-electron temperature in the positive column of the discharge. This is usually of the order of 10^3 – 10^4 degrees K.

In order to scale such a discharge to shorter wavelengths, it must still be possible to match it to a waveguide, and the electron temperature must remain the same (or higher) at the shorter wavelength. By reducing the dimensions of the gas tube and increasing the pressure, both linearly with wavelength, it can be shown⁶ that the electron temperature remains constant. Furthermore, if the scaling has been done in the above way, the tube current required to give a match is unchanged.

TUBE AND MOUNT FOR 8 MM

Using these principles, a tube and waveguide mount have been designed for the 8 mm wavelength band. These are illustrated in Fig. 1.

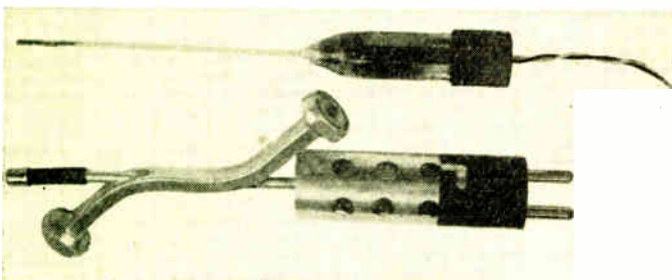

Fig. 1—8 mm noise tube and mount.

* Decimal classification: R355.913.21. Original manuscript received by the IRE, September 11, 1953; revised manuscript received, November 27, 1953.

† Royal Naval Scientific Service, Services Electronics Research Lab., Baldock, Herts., England.

¹ W. W. Mumford, "A broad-band microwave noise source," *Bell Sys. Tech. Jour.*, vol. 28, p. 608; October, 1949.

² H. Johnson and K. R. Deremer, "Gaseous discharge super-high frequency noise sources," *Proc. I.R.E.*, vol. 39, p. 908; August, 1951.

³ P. Parzen and L. Goldstein, "Current fluctuations in dc gas discharge plasma," *Phys. Rev.*, vol. 79, p. 190; July, 1950.

⁴ M. A. Easley and W. W. Mumford, "Electron temperature vs noise temperature in low pressure mercury-argon discharges," *Jour. Appl. Phys.*, vol. 22, p. 846; June, 1951.

⁵ J. D. Cobine, "Gaseous Conductors," McGraw-Hill Book Co., Inc., New York, N. Y.; 1951.

The part of the discharge tube that lies in the waveguide is 0.1 inch diameter, which opens out at one end into a bulb, containing a hot cathode. Mounting is in the *E*-plane, at an angle to the waveguide. To give room for the cathode end of the tube, and the anode connection, the waveguide is made with a double bend.

The chief difficulty experienced in the design lay in keeping the glass losses of the tube small. By using a thin-walled tube (<0.01 inch) however, it was possible to keep the loss down to about 0.5 db. Both neon and argon fillings have been used. With neon at a pressure of 30 mm Hg, and argon at 20 mm Hg, good matches were obtained with current above about 40 mA. Some of the measured characteristics of the tubes are given in the following table.

TABLE I

Tube No.	1	3
Gas	Ne	A
Gas pressure mm Hg	30	20
Insertion loss (discharge off) db	0.7	0.3
VSWR (discharge off: match behind)	1.1	1.13
VSWR (discharge on: short behind)	1.15	1.1
Tube current mA	45	35
Measured noise temperature, degrees K	19,300	11,500
Noise figure db	18.2	15.9
Calculated noise temperature, degrees K	21,000	10,000

MEASUREMENT OF NOISE TEMPERATURE

The amount of noise radiated from these tubes was measured on a microwave radiometer.⁶ Comparison was made with a hot load at 500 degrees C., giving a direct measurement of noise temperature. The tubes containing neon gave a noise temperature of 19,300 degrees K, and those with argon 11,500 degrees K. Calculated values⁵ from gas discharge theory are 21,000 degrees K and 10,000 degrees K, respectively.

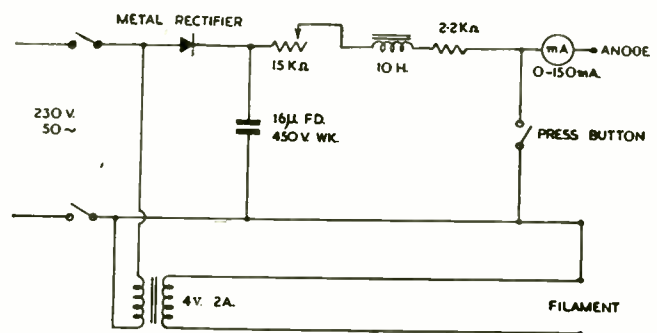

Fig. 2—Power unit for noise tube.

⁶ R. H. Dicke, "The measurement of thermal radiation at microwave frequencies," *Rev. Sci. Instr.*, vol. 17, p. 268; July, 1946.

POWER SUPPLY

A suitable power supply for the tube is shown in Fig. 2. The running voltage of the tubes is about 120, but 600-700 volts are required to strike the discharge. In order to supply this momentary over-voltage, a choke, carrying current, is suddenly open-circuited by means of a push-button switch.

ACKNOWLEDGMENT

The author is indebted to G. R. Nicoll, Radar Research Establishment, Malvern, England, for use of the 8 mm radiometer designed by him, and for assistance in making the noise-temperature measurements. He also wishes to thank P. O. Hawkins for helpful advice, and the Admiralty, for permission to publish this paper.

Transient Response in FM*

IGOR GUMOWSKI†

Summary—The FM response to the unit impulse and the unit step function is calculated for a network whose transfer function is known. A meaning is assigned to the associated Fourier integral, which diverge in the Riemann sense. The method is generalized to any input function which vanishes for negative t . As an illustration of the method the impulse and the step FM responses of a single tuned circuit are calculated.

THE GENERAL METHOD

THE CALCULATION of transient response in FM is no more difficult than the calculation of transient response in AM. In fact, the method to be used is essentially the same.

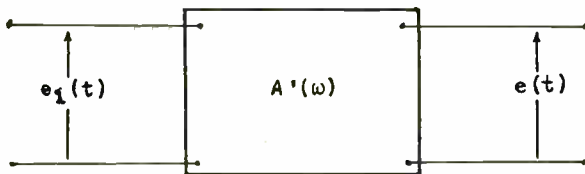

Fig. 1

If $A'(\omega)$ is the transfer function (complex system function) of the network whose response to the signal $e_i(t)$ is to be calculated (Fig. 1), the solution $e(t)$ can be obtained in all cases from the following relation:

$$e(t) = \frac{1}{2\pi} \int_{-\infty}^{\infty} e^{j\omega t} A'(\omega) \int_{-\infty}^{\infty} e^{-j\omega x} e_i(x) dx d\omega. \quad (1)$$

From the physical point of view the above solution represents the well known principle of harmonic balance, and it is thus equally valid for FM as for AM. From the mathematical point of view, (1) represents simply the inverse Fourier transform of the product of the network transfer function by the transform of the input signal. If $f(t)$ is the signal to be transmitted, then the input voltage $e_i(t)$ becomes

$$e_i(t) = f(t)e^{j\omega_0 t} \quad (2a)$$

for AM (suppressed carrier modulation), and

* Decimal classification: R148.2. Original manuscript received by the IRE, July 22, 1953; revised manuscript received, November 20 1953.

† Dept. of Elec. Eng., Laval University, Quebec, P. Q., Can.

$$e_i(t) = e^{jF(t)} e^{j\omega_0 t} \quad (2b)$$

for FM, where

$$F(t) = \int_{-\infty}^t f(x) dx \quad (2c)$$

and ω_0 is the angular frequency of the carrier.

However, if this well known solution is used in a practical case, there appears a serious difficulty. When such popular functions as the unit step $Y(t)$ or the unit impulse $\delta(t)$ are chosen for the signal to be transmitted, it is found that the Fourier transform of $e_i(t)$ does not exist in the Riemann sense. This difficulty can be eliminated by using mathematically more complex signals to insure the existence of the integrals in the Riemann sense, but unfortunately the mathematical complication thus added renders the resulting solution quite unwieldy.

For theoretical as well as practical purposes, it is more advantageous to keep the divergent integrals and consider these integrals in the sense of the distribution theory (1), instead of considering them in the Riemann sense. In such a case it is easily verified that the Fourier transforms of $e_i(t)$ for $f(t) = a\delta(t)$, $-\pi < a < +\pi$, and $f(t) = aY(t)$, $-\infty < a < +\infty$, become respectively

$$\int_{-\infty}^{\infty} e^{-j\omega t} \cdot e^{jaY(t)} \cdot e^{j\omega_0 t} dt = \pi(e^{ja} + 1)\delta(\omega - \omega_0) + j \frac{e^{ja} - 1}{\omega - \omega_0} \quad (3)$$

$$\int_{-\infty}^{\infty} e^{-j\omega t} \cdot e^{jaY(t)} \cdot e^{j\omega_0 t} dt = \pi\delta(\omega - \omega_0) + \pi\delta(\omega - \omega_0 - a) + j \frac{a}{(\omega - \omega_0)(\omega - \omega_0 - a)}. \quad (4)$$

If the transfer function $A'(\omega)$ of the network is known, the transient response $e(t)$ can be calculated in a straightforward manner. In fact, letting $A'(\omega) = A(\omega - \omega_0)$ the FM impulse response of the network becomes

$$\begin{aligned}
 e(t) &= \frac{1}{2\pi} \int_{-\infty}^{\infty} e^{j\omega t} A'(\omega) \pi(e^{ja} + 1) \delta(\omega - \omega_0) d\omega \\
 &\quad + \frac{j}{2\pi} \int_{-\infty}^{\infty} e^{j\omega t} A'(\omega) \frac{e^{ja} - 1}{\omega - \omega_0} d\omega \\
 &= \frac{1}{2} (e^{ja} + 1) e^{j\omega_0 t} \int_{-\infty}^{\infty} e^{jx t} A(x) dx \\
 &\quad - \frac{e^{ja} - 1}{2\pi} e^{j\omega_0 t} \int_{-\infty}^{\infty} e^{jx t} A(x) \frac{dx}{jx} \\
 &= e^{j\omega_0 t} \left[A(0) e^{ja} - (e^{ja} - 1) \int_{-\infty}^t u(x) dx \right], \quad (5a)
 \end{aligned}$$

where

$$u(t) = \frac{1}{2\pi} \int_{-\infty}^{\infty} e^{jx t} A(x) dx \quad (5b)$$

is the impulse response (Green's function, weighting function) of the associated low-pass network. It is important to note that $u(t)$ does not have to be purely real, i.e., the associated low-pass network does not have to satisfy any conditions of "physical realizability."

If the FM impulse response is applied to a perfect discriminator, the detected response will be given by the derivative of the phase angle of the expression inside the brackets. In particular, if $u(t)$ is purely real, i.e. if the network of Fig. 1 was obtained from a low-pass network by means of a frequency translation, then the detected response is given by

$$e_d(t) = \frac{d}{dt} \arctan \frac{A(0) \sin a - \sin a \int_{-\infty}^t u(x) dx}{A(0) \cos a + (1 - \cos a) \int_{-\infty}^t u(x) dx} \quad (6)$$

The FM step-function response is found in a similar manner:

$$\begin{aligned}
 E(t) &= \frac{1}{2\pi} \int_{-\infty}^{\infty} e^{j\omega t} A'(\omega) [\pi \delta(\omega - \omega_0) + \pi \delta(\omega - \omega_0 - a)] d\omega \\
 &\quad + \frac{1}{2\pi} \int_{-\infty}^{\infty} e^{j\omega t} A'(\omega) \frac{ja}{(\omega - \omega_0)(\omega - \omega_0 - a)} d\omega \\
 &= e^{j\omega_0 t} \left[\frac{1}{2} A(0) + \frac{1}{2} A(a) e^{ja t} \right. \\
 &\quad \left. + \frac{ja}{2\pi} \int_{-\infty}^{\infty} e^{jx t} \frac{A(x)}{x(x - a)} dx \right] \\
 &= e^{j\omega_0 t} \left[A(0) + e^{ja t} \int_{-\infty}^t e^{-jax} u(x) dx \right. \\
 &\quad \left. - \int_{-\infty}^t u(x) dx \right], \quad (7a)
 \end{aligned}$$

where again

$$u(t) = \frac{1}{2\pi} \int_{-\infty}^{\infty} e^{jx t} A(x) dx. \quad (7b)$$

If $u(t)$ is purely real, the detected step-function response will be given by

$$\begin{aligned}
 E_d(t) &= \frac{d}{dt} \arctan \frac{\int_{-\infty}^t u(x) \sin a(t-x) dx}{A(0) + \int_{-\infty}^t u(x) \cos a(t-x) dx - \int_{-\infty}^t u(x) dx} \quad (8)
 \end{aligned}$$

If the input signal $e_i(t)$ is of a more general form,

$$e_i(t) = e^{jF(t) \cdot Y(t)} \cdot e^{j\omega_0 t}, \quad (9)$$

where

$$F(t) = \int_{-\infty}^t f(x) dx$$

is an arbitrary function, the FM transient response becomes simply

$$\begin{aligned}
 e(t) &= e^{j\omega_0 t} \left[A(0) + \int_{-\infty}^t e^{jF(t-x)} u(x) dx \right. \\
 &\quad \left. - \int_{-\infty}^t u(x) dx \right]. \quad (10)
 \end{aligned}$$

Examining the calculated FM transient responses we notice that they are determined completely by the impulse response $u(t)$ of the associated low-pass network. Since $u(t)$ depends both on the amplitude and the phase characteristic (obtained by steady state sine wave analysis) of the network of Fig. 1, the complete and the detected FM transient responses do also. It is thus necessary to consider both the bandwidth and the phase-shift when designing a network for a given FM transient response.

FM TRANSIENT RESPONSE OF A SINGLE-TUNED CIRCUIT

As an illustration of the general method described previously let us determine the FM transient response of a single-tuned circuit (Fig. 2) when the input signal

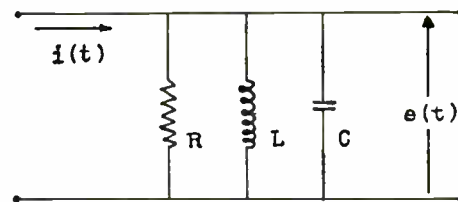

Fig. 2

is fed from a constant current source. By elementary analysis it is found that the transfer function of this network is given by

$$A'(\omega) = R \frac{d}{d + j \left(\frac{\omega}{\omega_0} - \frac{\omega_0}{\omega} \right)}$$

where

$$\omega_0^2 = \frac{1}{LC} \quad \text{and} \quad d = \frac{1}{\omega_0 RC} \quad (11a)$$

If the bandwidth is small compared with the resonant frequency $\omega_0/2\pi$, then this transfer function simplifies to

$$A'(\omega) = R \frac{\frac{1}{2}d}{\frac{1}{2}d + j\left(\frac{\omega - \omega_0}{\omega_0}\right)} \quad (11b)$$

Hence, the transfer function $A(x)$ of the associated low-pass network is

$$A(x) = R \frac{\frac{1}{2}d}{\frac{1}{2}d + j\frac{x}{\omega_0}} \quad (12)$$

and its impulse response is

$$\begin{aligned} u(t) &= \frac{1}{2\pi} \int_{-\infty}^{\infty} e^{ixt} A(x) dx = \frac{Rd}{4\pi} \int_{-\infty}^{\infty} \frac{e^{ixt} dx}{\frac{1}{2}d + j\frac{x}{\omega_0}} \\ &= \frac{1}{2} R d \omega_0 Y(t) e^{-(d\omega_0/2)t} \end{aligned} \quad (13)$$

Therefore, if $f(t) = a\delta(t)$, i.e. $i(t) = e^{iaY(t)} \cdot e^{j\omega_0 t}$, the FM impulse response will be given by

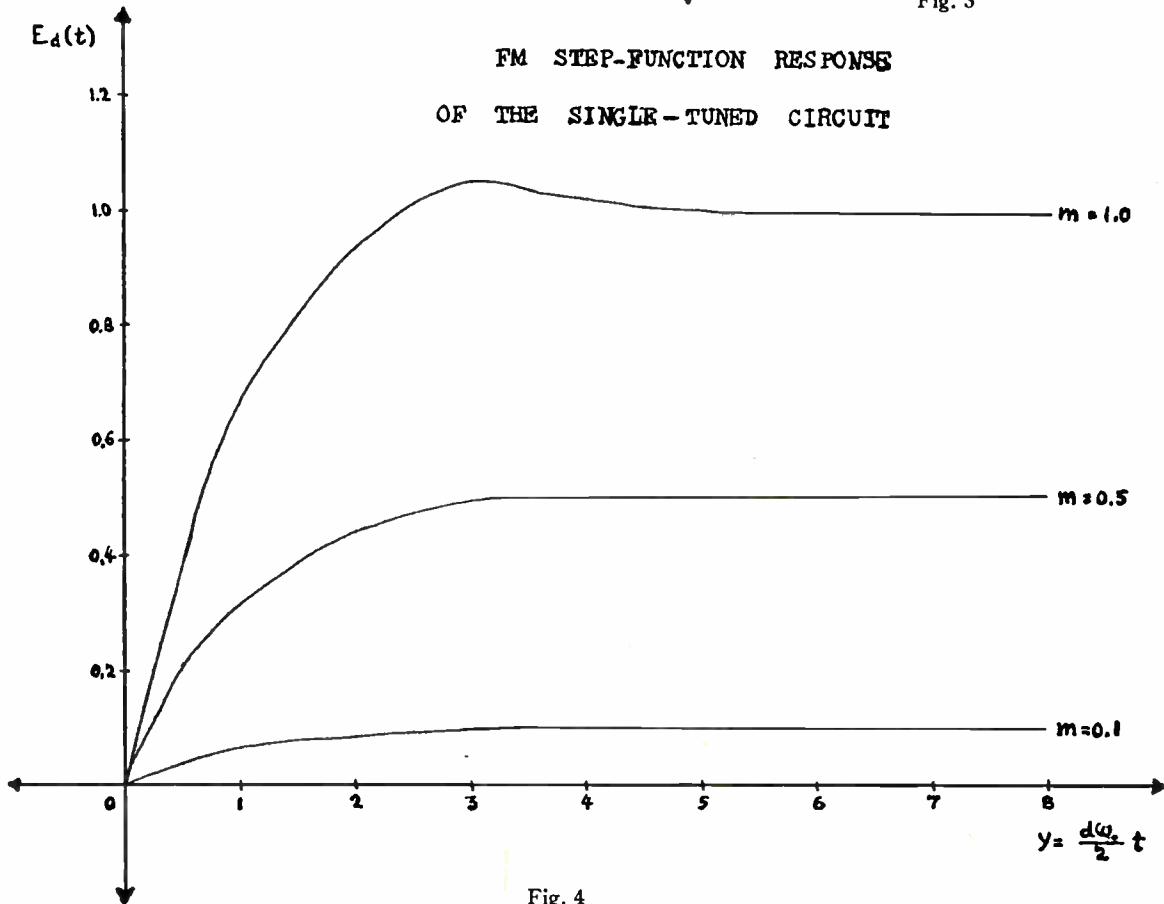
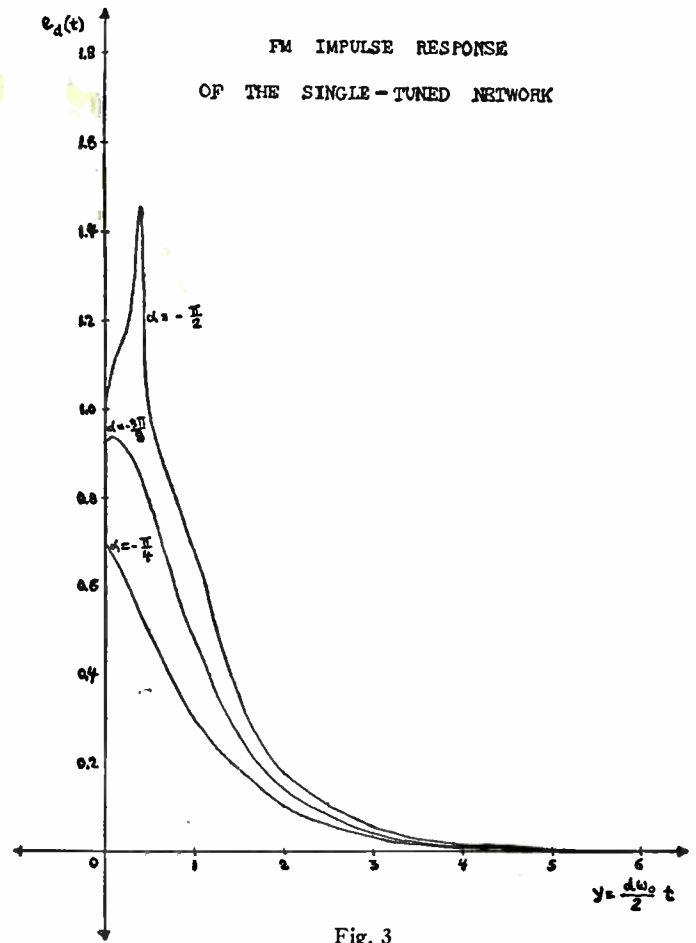

$$e(t) = Re^{j\omega_0 t} \left[e^{ja} - (e^{ja} - 1) \frac{d\omega_0}{2} \int_{-\infty}^t Y(x) e^{-(d\omega_0/2)x} dx \right]$$

$$e(t) = \begin{cases} Re^{j\omega_0 t} \cdot e^{ja} & \text{for } t < 0 \\ Re^{j\omega_0 t} [1 + e^{ja} \cdot e^{-(d\omega_0/2)t} - e^{-(d\omega_0/2)t}] & \text{for } t > 0, \end{cases} \quad (14)$$

and the detected response becomes

$$e_d(t) = \frac{d}{dt} \operatorname{arc\,tg} \frac{\sin a e^{-(d\omega_0/2)t}}{1 + (\cos a - 1) e^{-(d\omega_0/2)t}} \quad (15)$$

To examine how the detected impulse response varies with the phase sweep a , it is only necessary to plot $e_d(t)$ vs $\frac{1}{2}d\omega_0 t$ for various values of $-\pi < a < +\pi$ (Fig. 3).

However, usually it is more convenient to determine how the transient response is related to the frequency sweep instead of to the phase sweep. This can be easily accomplished by considering the FM response to the step function. In fact,

$$E(t) = e^{j\omega_0 t} \left[R + e^{ja} \int_{-\infty}^t e^{-j\alpha x} \cdot \frac{Rd\omega_0}{2} \cdot e^{-(d\omega_0/2)x} Y(x) dx - \int_{-\infty}^t \frac{Rd\omega_0}{2} e^{-(d\omega_0/2)x} \cdot Y(x) dx \right]$$

$$= \begin{cases} Re^{j\omega_0 t} & \text{for } t < 0 \\ Re^{j\omega_0 t} \left[\frac{1}{1 + j \frac{2a}{d\omega_0}} \left(e^{ja} + j \frac{2a}{d\omega_0} e^{-(d\omega_0/2)t} \right) \right] & \text{for } t > 0. \end{cases} \quad (16)$$

Since $d\omega_0/2\pi$ is the bandwidth of the single-tuned circuit and $2a/d\omega_0$ can be considered as the "sweep index," the response $E(t)$ can be easily written in a per-unit form.

Letting $y = \frac{1}{2}d\omega_0 t$ and $m = 2a/d\omega_0$ we obtain for $t > 0$

$$E(t) = Re^{j\omega_0 t} \left[\frac{1}{1 + jm} (e^{jmy} + jme^{-y}) \right] \quad (17)$$

and

$$E_d(t) = \frac{d}{dt} \operatorname{arc\,tg} \frac{me^{-y} + \sin my - m \cos my}{me^{-y} + \cos my + m \sin my} \quad (18)$$

Fig. 4 shows the step-function responses for $m = 0.1$, $m = 0.5$ and $m = 1$.

Examining the plotted responses we notice that the quality of the FM transmission decreases as the frequency or the phase sweep increases. Especially, when the frequency sweep is equal or greater than the bandwidth of the single-tuned circuit, or when the phase sweep is close to 180 degrees (a close to $\pm\pi$), the FM transient response is quite poor.

BIBLIOGRAPHY

- Bosse, G., "Die dynamischen Übertragungsgrößen eines Vierpols bei Frequenzmodulation," *Arch. elekt. Übertragung*, vol. 5, pp. 237-240; 1951.
- Carson, T. C., and Fry, J. R., "Variable frequency electric circuits theory with applications to the theory of frequency modulation," *Bell Sys. Tech. Jour.*, vol. 16, p. 513; 1937.
- Clavier, A. G., "Application of Fourier transforms to variable frequency circuit analysis," *Proc. I.R.E.*, vol. 37, pp. 1287-1290; 1949.
- Mann, P. A., "Die bei Übertragung von Impulsen mit FM auftretenden Impulsverformungen," *Telefunken-Zeitung*, vol. 92, pp. 140-143; 1951.
- Nadler, M., "Přechodná frekvenci a amplitudová modulace fázovým skokem," Prague, Czechoslovakia, *Slaboproudý Obzor*, vol. 1, pp. 20-22; 1952.
- Schwartz, L., "Théorie des Distributions," Paris, France, Hermann et Cie, 1951.
- Wilde, H., "Verzerrungen frequenzmodulierter Schwingungen am Schwingungskreis," *T.F.T.*, vol. 32, p. 7; 1943.

Unit Construction Practice (UCP) Applied to Line-Transmission Equipment*

KENNETH W. HARRISON†, SENIOR MEMBER, IRE

Summary—The equipment practice described and illustrated in this paper and referred to as Unit Construction Practice is based on the conception that the number of different circuit functions used in line-transmission technique is small and that these circuit functions can be performed by relatively few standardized components. Once these facts are recognized it is an obvious step to adopt an equipment practice in which a series of self-contained units, each comprising an assembly of standardized components and designed to perform a distinct circuit function, become the "bricks" which can be used in different combinations to build different types of systems.

* Decimal classification: R470. Original manuscript received by the IRE, July 23, 1953; revised manuscript received, December 8, 1953.

† Telephone Manufacturing Co. Ltd., Orpington, Kent, England.

It is claimed that the new practice results in equipment which offers a degree of standardization combined with flexibility and a ready adoption to civil or military purposes not possible using earlier practices. Considerable space-saving is also effected.

INTRODUCTION

THE RAPID EXPANSION in long-distance telegraphy and telephony, which took place during the five or six years prior to the second World War, was brought about by employing carrier-transmission methods to multiply the message-handling capacity of existing line facilities. The net result was that the

volume and complexity of inside plant materially increased and, already, at the outbreak of war the provision of building accommodation and skilled maintenance staff was becoming critical; at the end of the war it was even more so.

However, the aftermath of war brought certain compensations. For the first time large-scale application of carrier-transmission methods had been applied to the provision of military circuits. In the early part of the war extensive use was made of normal pre-war equipment. Experience showed that this equipment was too heavy and bulky for military operations, and too complex for relatively unskilled personnel to service satisfactorily. Efforts were directed towards the production of smaller and lighter components; new circuit techniques were developed, and, around these, new smaller and lighter equipment was designed and constructed. The problems of maintaining and operating equipment with semi-skilled personnel received special study. Maintenance and operating routines were simplified. In fact a new era in transmission technique began. However it was inevitable that the design of this wartime equipment was subservient to the overriding needs of the armed forces and only scant attention was paid to probable peace-time requirements.

Towards the end of 1948 the repercussions on line-transmission technique brought about by the war were becoming apparent. The manufacturers and armed forces had become acutely aware of the desirability of integrating the design of post-war equipment so that, if the need arose again, it could quickly be adapted to military requirements. All concerned had become conscious of the need for greater standardization to facilitate production, supply, and maintenance of equipment. All concerned had become conscious also of the need for smaller equipment so as to permit more efficient utilization of the limited building accommodation now available in the post-war world.

Early in 1949, the Company with which the writer is associated initiated a development project to provide a more rational approach towards the design of line-transmission equipment, and the following pages of this article outline the design principles underlying the Unit Construction Practice (UCP) which emerged as a result.

DESIGN CONSIDERATIONS

The principal consideration was to reconcile the conflicting claims of reliable and efficient performance, ease of maintenance, economy of mounting space, suitability alike for large and small administrations and ready adaptation for military purposes.

To ensure reliable and efficient performance it was decided, wherever possible, to avoid the use of abnormally miniaturized components, and to reduce the bulk of the equipment by efficient utilization of the available mounting space using normal approved and accepted types of components.

Experience during the war years had shown that although the mounting of groups of components in hermetically sealed containers provided excellent protection against the effects of humidity, maintenance, and stocking of spares became more costly. In view of this it was decided, whenever possible, to protect components individually against the ingress of moisture.

In earlier equipment practice the apparatus panels were mounted on both sides of a 3-inch channel iron-bay framework with the units projecting outward, thus wasting the space between front and rear panels. It was obvious that an economy of mounting space could be effected by a re-design of the bay framework. After consideration it was decided to mount the new equipment on two bay-side frameworks which when placed back-to-back would occupy the same floor space as an existing fully equipped double-sided bay.

Having decided what general category of components would be used and having, by consideration of the new bay-side frameworks, fixed the space available for mounting them, the next step was to study line-transmission circuit technique with the object of providing a greater degree of standardization.

Line-transmission systems comprise principally an assembly of entities, each of which performs a different but distinct circuit function, for example, amplification, modulation, filtration and so forth, all of which contribute to the performance of the system as a whole. A study of earlier practice showed that the assemblies of components required to perform these functions were rarely designed as self-contained units. Furthermore, assemblies of components used in one particular type of equipment were usually different from assemblies used in another type of equipment even though these assemblies were designed to perform essentially similar functions.

Further study revealed to what remarkable degree the same, or basically the same entities could be used without change to build different types of transmission systems. At this stage it was a logical step to conceive the idea of a series of standardized self-contained units, of a size and shape fully to utilize the available bay-side framework mounting space, which would become the "bricks" that could be used in different combinations to build different systems. In general each unit would be designed to perform only one circuit function and care would be taken to ensure that its electrical performance was suitable for as many different applications as possible. For obvious reasons these "bricks" became styled Functional Units.

Attention was next directed towards the best method of mounting these "bricks" in various combinations to form appropriate panel assemblies. A universal type of panel frame held special appeal and compared favorably with earlier equipment practice where it was necessary to drill and tap each mounting plate in a manner peculiar to the particular panel assembly required.

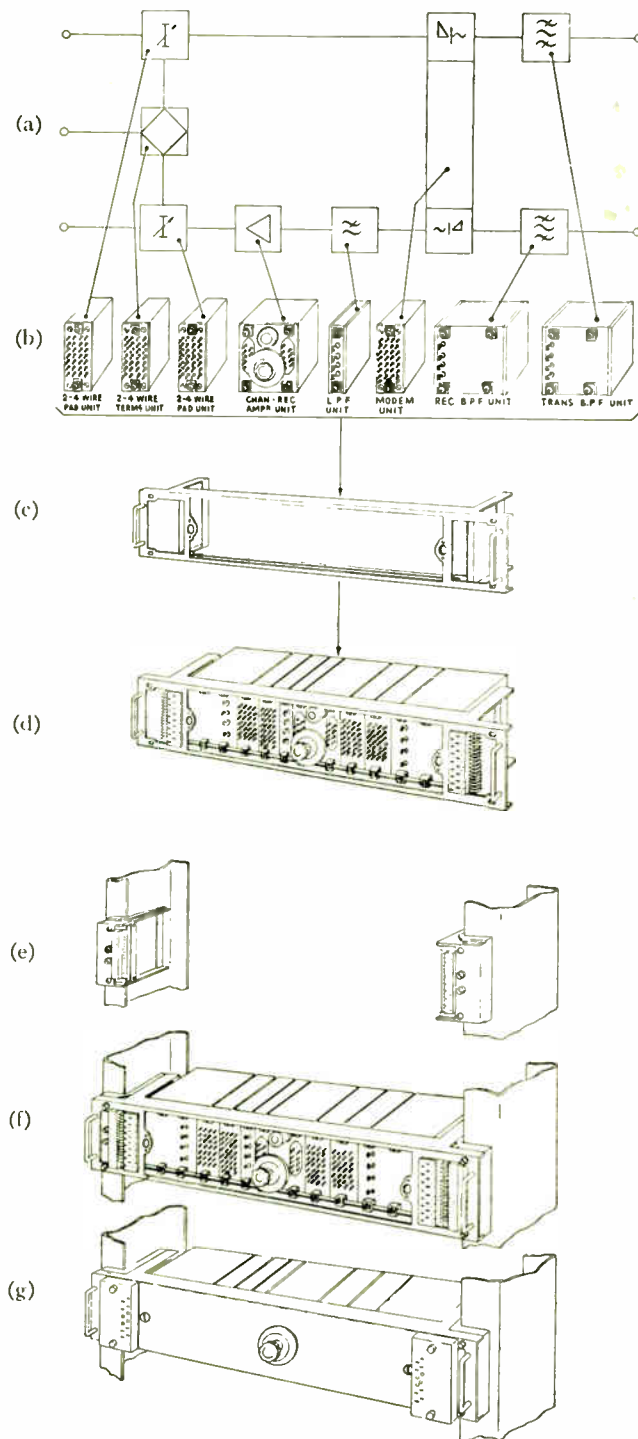

Fig. 1(a) to (g)—Schematic showing the principles of UCP applied to the design of a typical "channel panel" for a carrier-telephone system.

Thought next turned to the problem of making the bay-to-panel connections. It seemed that the advantages of quickly detachable jack-in panels could not be ignored. However, the prejudices against the use of dry contacts in circuits carrying small currents was still considerable. Eventually it was decided to arrange for the panel to jack into the bay-side but also to make provision so that, if desired, the jack contacts could be bridged by short soldered straps.

PRINCIPLES OF UCP

The principles of the new practice are illustrated by Figs. 1(a) to 1(g) which gives an example of a typical "channel panel" for use in a carrier-telephone equipment.

Fig. 1(a) shows a block schematic of the panel. Each distinct circuit function, indicated by separate blocks on the schematic, is performed by a Functional Unit. Fig. 1(b) illustrates the Functional Units required.

Fig. 1(c) illustrates the universal panel frame, and Fig. 1(d) shows the Functional Units mounted on it.

Fig. 1(e) shows a section through the side members of the bay-side framework, and Fig. 1(f) the bay-side framework with the panel mounted on it. The connections between bay and panel wiring are made by plug and socket assemblies which also provide test points for routine measurements.

Fig. 1(g) shows the panel fitted with its dust cover. This is a flat plate attached at each end by quick release fasteners.

From this example it will be clear that, with the exception of the band-pass filter units, the same Functional Units can be used over and over again to build "channel panels" for many different carrier systems. Furthermore, if each unit is designed to have a high return loss at its input and output, then the over-all frequency response characteristic of any combination of units will be substantially the algebraic sum of the characteristics of the individual units. This is of considerable advantage when designing systems to meet specific performance requirements since it is possible for the designer to predetermine with reasonable precision what over-all performance can be expected from a given combination of units.

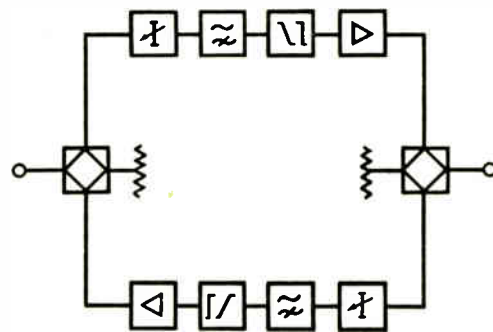

Fig. 2—Block schematic of a VF 2-wire repeater panel.

Consider next the typical 2-wire voice-frequency repeater panel shown in block schematic form in Fig. 2. It can readily be shown that the 2/4-wire terminating units, pad units and voice-frequency amplifier units can be identical to those used to build up the channel panel referred to in the previous example. A study of line-transmission technique will reveal many other examples where some or all of these typical Functional Units can be used in different combinations to build different types of systems.

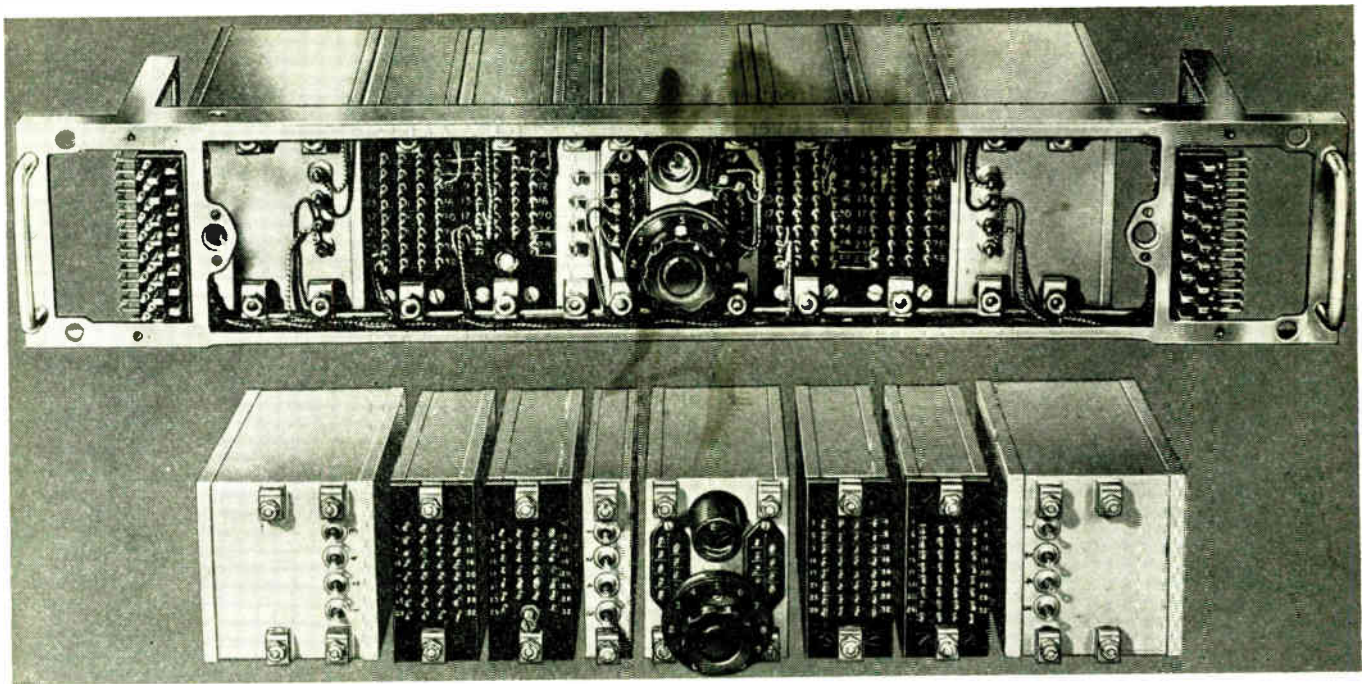

Fig. 3—Typical UCP carrier-telephone "channel panel."

It will be seen that the principles of UCP are based on the conception that the number of different circuit functions employed in line transmission technique is small and that these circuit functions can be performed by relatively few standardized components. Once these facts are recognized it is an obvious and logical step to adopt an equipment practice in which a minimum number of self-contained units, each comprising an assembly of standardized components and designed to perform a specific circuit function, are used in different combinations to build different types of equipment.

DESIGN FEATURES

It has been shown that the fundamental entities of UCP are Functional Units and that these units are assembled in various combinations on universal panel frames which are jacked into the bay-side. The following pages describe certain design features of the Functional Units, universal panel frames and bay-side frameworks used in the new equipment practice.

A. Functional Units

The majority of the Functional Units comprise a simple metal framework in which the various components are mounted, a top plate mounting terminal tags and any necessary controls, and a metal cover which encloses the whole assembly. Each unit is so designed that the whole of the mounting space within the framework is fully utilized. In the larger units components and wiring are made more accessible by hinging the frameworks.

The mechanical design of filter and equalizer network units remains substantially unchanged from earlier equipment practice. However, a considerable size reduc-

tion has been achieved by the use of silvered mica and/or polystyrene capacitors, and smaller powder core inductors having improved intermodulation characteristics.

Fig. 3 shows the Functional Units required to build up the typical channel panel shown diagrammatically in Fig. 1. All these units are designed to mount on to a $3\frac{1}{2}$ -inch panel frame. It has been found that with few exceptions this one height of unit is sufficient for all purposes. Figs. 4 (and 5, following page), show exposed views of two typical units.

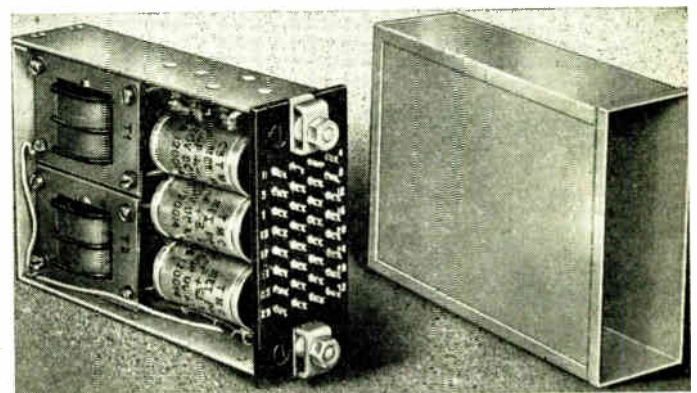
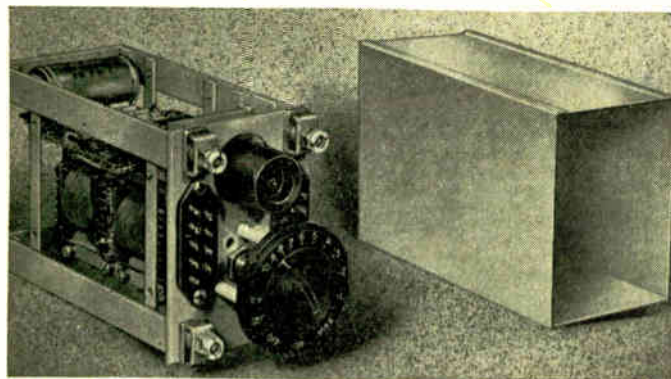

Fig. 4—2/4-wire Functional Unit.

It is interesting to consider the design of the single tube voice-frequency amplifier shown in Fig. 5. This amplifier is so designed that it may be used as a channel-receive amplifier in all types of carrier-telephone systems, and as a line amplifier in voice-frequency telegraph systems, 2-wire and 4-wire voice-frequency repeater systems, 2-band systems, privacy systems, etc.

Study of these applications showed the amplifier required to have maximum working gain of 44 db, about 10 db of negative feedback, substantially flat frequency response and high input and output return loss over frequency range of 300 cps to 3,400 cps, power handling capacity of +17 dbm with harmonic distortion not greater than 30 db, and to operate from HT supply of 150v. Using 6AK5 tube and modern circuit technique it was relatively easy to meet this specification.



(a)

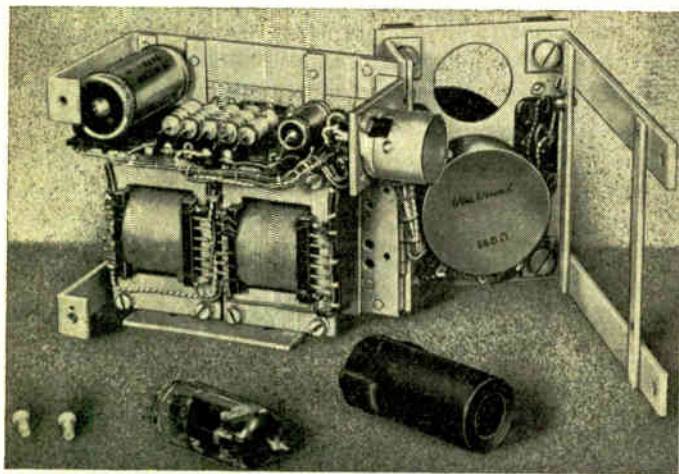

(b)

Fig. 5(a) and (b)—VF amplifier Functional Unit showing how unit framework is hinged to give accessibility to wiring and components.

B. Panel Frames

The structural form of the panel frame is shown in the line drawings of Fig. 1 and the method of attaching Functional Units to it is shown in Fig. 6. To provide light weight combined with adequate strength to withstand vibration and shock effects the frame is constructed throughout of sheet steel.

When the Functional Units are mounted on the panel frame the wiring between units lies all in one plane and the terminal tags of the units are accessible for making voltage and level measurements. This has particular advantage from a point of view of servicing and maintenance. If fault develops on any panel, it is possible, by making level measurement at input and output of each unit in turn, quickly to locate the faulty unit which may then be disconnected and replaced without difficulty.

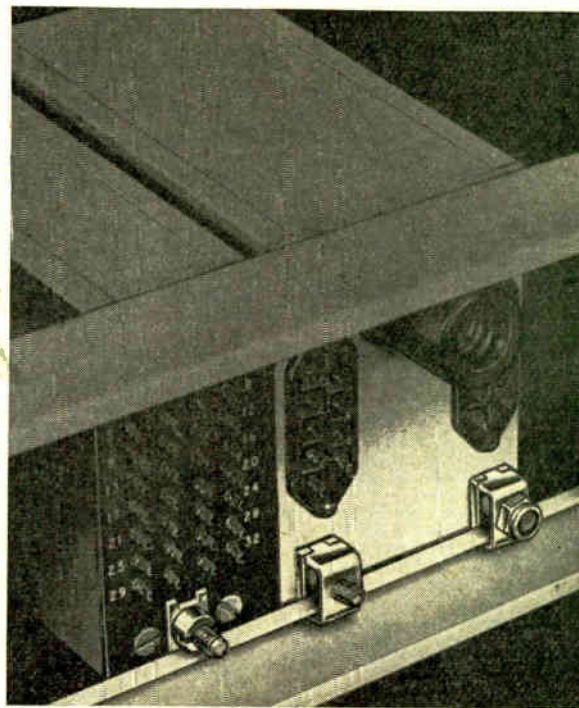

Fig. 6—Method of attaching Functional Units to panel frame.

The end members of the panel frame in combination with details fitted to the bay-side framework form what are known as "panel slides." These slides provide means for guiding the panel into position and taking the weight while it is being fitted to or removed from the bay-side. They also provide means for mounting the plug and socket assemblies for making connections between panel and bay wiring.

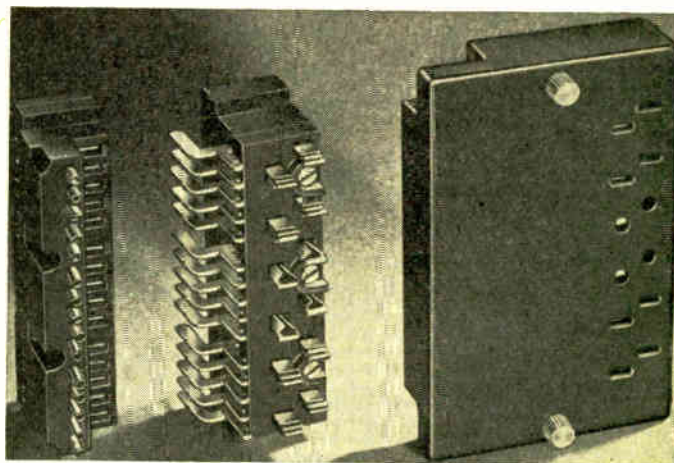

Fig. 7—Plug and socket assembly used in the new equipment practice.

C. Panel-to-Bay Connections

The design of the plug and socket assemblies is evident from Fig. 7. Accurate registration of blades and sockets is ensured by the panel slides. Provision is made for wiring across the contacts if desired, and sockets for routine measurements are provided on the panel plugs.

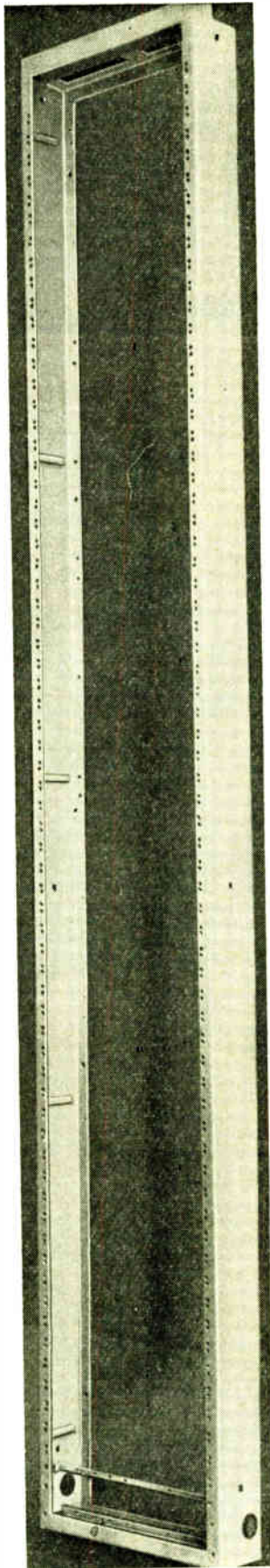

Fig. 8—Bay-side framework. The framework is constructed throughout of lightweight folded sheet steel.

D. Bay-side Framework

Fig. 8 shows new bay-side framework, is constructed throughout of folded sheet steel, and how a step is formed at top to carry office and inter-bay cabling.

E. Miscellaneous Panels

The number of bay-to-panel connections which can be provided by the plug and socket assemblies is of necessity restricted, and a maximum of thirty outlets is available on a $3\frac{1}{2}$ -inch jack-in panel frame. This number is adequate for most purposes; occasionally, however, a greater number is required, and when this is necessary, the panel is hinged at one end and the bay cable wired direct to the panel units.

Sometimes instances arise where it is more convenient to depart from the Functional Unit principle, and either to combine more than one circuit function in the same unit, or to provide the required circuit function by a combination of units. A typical example of the latter is seen in Fig. 9, which shows the line amplifier for a 12-channel open-wire carrier-telephone equipment. The amplifier is built up from four separate units, namely, input attenuator, input stage, intermediate stage, and output stage. These units are mechanically similar to Functional Units used in other parts of the equipment.

CONCLUSIONS

An attempt has been made to describe and illustrate the design principles of UCP and to outline the considerations which led up to its development. The new practice is based on the conception that the number of different circuit functions employed in line-transmission technique is small, and that these functions can be performed by relatively few standardized components. Advantage is taken of these facts by designing a self-contained unit series, each comprising an assembly of standardized components and in general performs a distinct circuit function. These Functional Units are used in different combinations to build different types of systems.

It is considered that the new practice offers a more rational approach to the design of line-transmission equipment than is possible using earlier practice. From the manufacturing viewpoint, the production advantages of building equipment from a limited number of standardized units are obvious. So far as the user is concerned, the advantages are in terms of ease of maintenance and testing routines, and the stocking of spare parts. Both user and manufacturer alike benefit because quantities of panel frames, bay-side frameworks, and Functional Units can be held in stock, and different types of systems built up with a minimum of delay.

The first costs of UCP equipment compare favorably with earlier equipments designed to meet similar performance requirements. This is to be expected since, by restricting the different types of unit to a minimum, a greater control over the quality and uniformity of the product is possible, and standardized production and testing methods can be adopted.

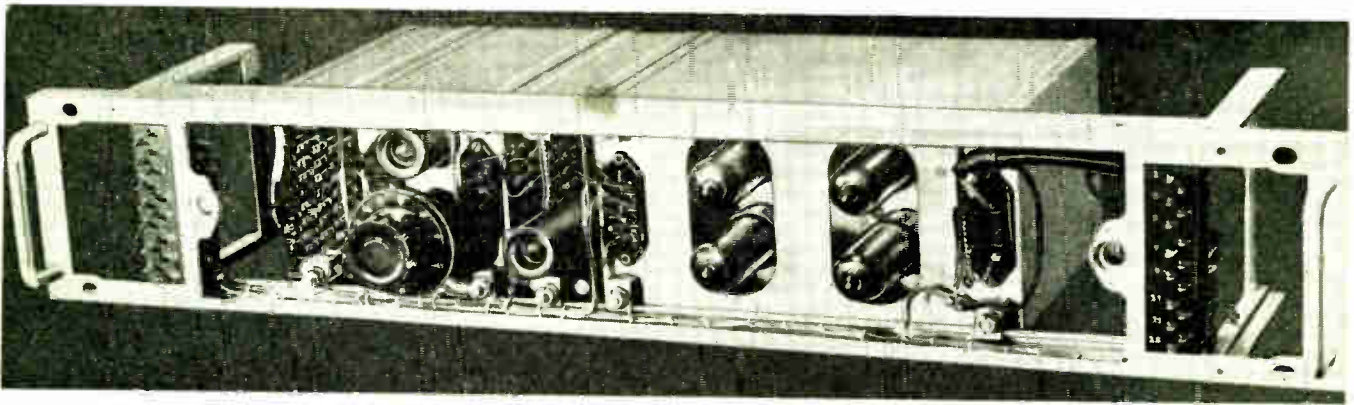

Fig. 9—Line amplifier for a 12-channel open-wire carrier-telephone system.

UCP equipment is not "miniaturized" in the sense that the term is often used. The reduction in bulk, evident from the group of 12-channel carrier-telephone terminal equipments shown in Fig. 10, in comparison with earlier equipment is as much as two- or three-fold. This has been achieved by efficient utilization of the available mounting space rather than by the use of abnormally miniaturized components. In spite of the considerable space-saving it will be seen from the illustrations that accessibility has been improved over that provided by earlier equipment practices.

Because the various Functional Units are so designed that they may be used in a variety of system applications, it is necessary for only a limited number of different types of units to be held in stock to serve as spares for a wide range of systems. Furthermore, since the panels can readily be detached from the bay-side frameworks and the units easily removed from the panel frames, in the event of a fault occurring, a spare unit or panel can be fitted with a minimum waste of time and effort.

In the new practice the heavy double-sided channel iron racks used in earlier equipment practice have been abandoned in favor of lightweight folded sheet steel bay-side frameworks. This feature, coupled with the fact that the panels may readily be detached from the bay-side frameworks, is particularly useful during installation or transportation since the bay-side frameworks and the individual panels can be handled separately.

Summarizing it will be seen that the principal features of UCP equipment are a bay-side framework which permits the maximum use of the available mounting space, a universal jack-in panel frame, and a series of Functional Units which can be mounted in any combination on the panel frame. Each of these features benefits one or other aspect of line-transmission practice. Space-saving reduces the bulk of equipment required to provide a given service, thereby easing the problems associated with the provision of building accommodation. The jack-in panel enables service to be restored quickly in the event of a fault developing in the equipment. The provision of a minimum number of different types of Functional Units to satisfy all probable requirements not only eases the problems concerned with maintenance routines and the stocking of spare

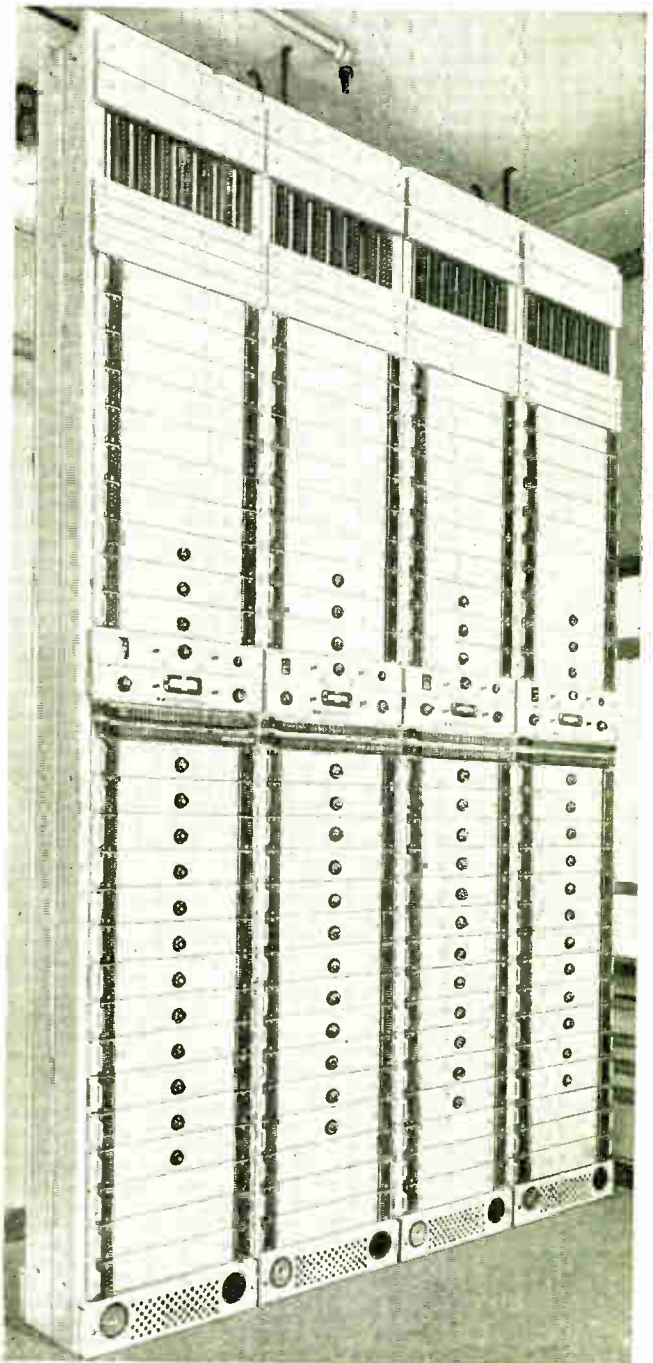

Fig. 10—Group of 12-channel carrier-telephone equipments for use on cable circuits. Each bay-side comprises a complete 12-channel terminal equipment.

parts, but also offers a degree of standardization combined with flexibility and a ready adaptation to civil or military purposes not possible using earlier equipment practice.

Although this article has dealt specifically with the application of UCP to line-transmission equipment, it is thought that the design principles of the new practice could be applied with advantage in other fields of electronic engineering. Essentially the design approach is to analyze the particular application envisaged, by means of functional block schematics, to make sure that the various circuit functions occur sufficiently frequently to

justify the method of attack, and then to design a minimum number of self-contained functional units which can be used over and over again as the "bricks" to build different equipments.

ACKNOWLEDGMENTS

The writer wishes to acknowledge his indebtedness to J. G. Flint, Technical Director, Telephone Manufacturing Co. Ltd., for permission to publish the information contained in the article, and to Messrs. Automatic Telephone and Electric Co. Ltd., for the use of certain photographs to illustrate the test.

Switching Time in Junction Diodes and Junction Transistors*

ROBERT H. KINGSTON†, ASSOCIATE MEMBER, IRE

Summary—The time in which a junction diode may be switched from forward to reverse conduction is of great importance in computing networks. By considering the behavior of the minority carriers in a diode in a representative switching circuit an approximate solution for the switching transient may be derived. The transient is separated into two phases: first, one of constant current, where the flow is limited by the external resistance, and second, a "collection" phase, where the current decays at a rate determined by the minority carrier lifetime and the dimensions of the diode. A critical parameter in the solution is the ratio of the short-circuit reverse current to the forward current before switching. The mathematical treatment is a boundary value solution of the minority carrier diffusion equations which is accomplished by the use of Laplace transformations. The duration of the two phases of current flow is determined for a planar junction, a hemispherical junction, and for a planar junction with junction-to-contact distance small compared to a diffusion length. The last treatment is extended to the junction transistor and the behavior of the collector current is calculated. The general results indicate that for a given minority carrier lifetime the last two of the three diode structures will give the smallest switching times. In addition it is found generally that the time is minimized by decreasing lifetime and increasing the ratio of reverse to forward current.

INTRODUCTION

IN THE USE of junction diodes in computer-switching circuits the switching time of the diode from forward to reverse voltage is of great importance. The problem may be represented as follows: In Fig. 1, a forward current, I_f , is flowing in the diode; at time, $t=0$, the switch, S , is thrown to the right. The switching time may now be defined as that time in which the voltage, V_D , reaches 90 per cent of the battery voltage. (The final static resistance of the diode is assumed to be much greater than R_0 .)

* Decimal classification: R282.12. Original manuscript received by the IRE, August 7, 1953.

The research in this document was supported jointly by the Army, Navy, and Air Force under contract with the Massachusetts Institute of Technology.

† Lincoln Laboratory, MIT, Cambridge, Mass.

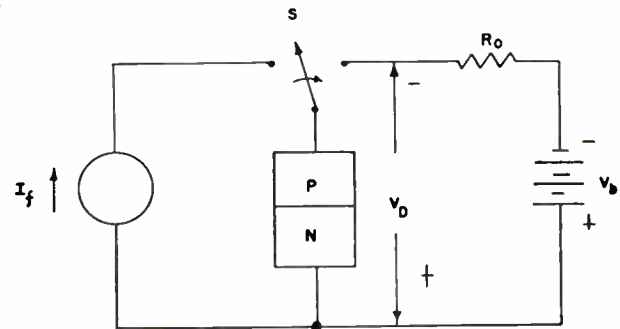

Fig. 1—Representative switching circuit.

PHYSICAL MODEL¹

For simplicity, the treatment to follow is applied to a $p-n$ junction where the conductivity of the p -type material is much greater than that of the n -type material. Practical embodiments of such a model are the familiar bonded n -type diodes and indium alloy-process devices. This limitation gives the qualitative picture of the carrier and potential distribution shown in Fig. 2. Here, the energy-band representation shows a forward current, I_f , proportional to the negative gradient of the hole concentration at the right of the barrier. The electron density in the p -type material is negligible since $\sigma_p \gg \sigma_n$ and is therefore neglected.

Given the above initial picture of the junction, it is now necessary to consider the behavior of the system after $t=0$, when the diode is switched into the reverse-biasing circuit. To anticipate the results it may be stated immediately that the initial transient in the circuit will be a constant current, given by V_b/R_0 . That is, for a reasonable length of time after switching, the voltage

¹ The physical description follows the methods and notation of W. Shockley, "Electrons and Holes in Semiconductors," D. Van Nostrand Co., Inc., New York, N. Y.; 1950, or "The theory of $p-n$ junctions in semiconductors and $p-n$ junction transistors," *Bell Sys. Tech. Jour.*, vol. 28, p. 435; 1949.

across the junction will be small compared to the battery voltage; therefore, the current will be completely determined by the series resistance. (A practical circuit might have a battery voltage of 20 v and a series resistance of 20,000 ohms.) It should be emphasized that the voltage across the junction (the "space charge" voltage) does not change abruptly at $t=0$; actually, it is a dependent function of the hole density at the barrier which in turn is determined by the flow of diffusion

current. The former is unlikely since the space-charge current, $I_n = CdV/dt$, is found to be negligible compared to the diffusion current, and the latter is ruled out by the high conductivity of the p -type material. The remainder of the treatment is concerned with the mathematical solution of the diffusion equations subject to the boundary conditions.

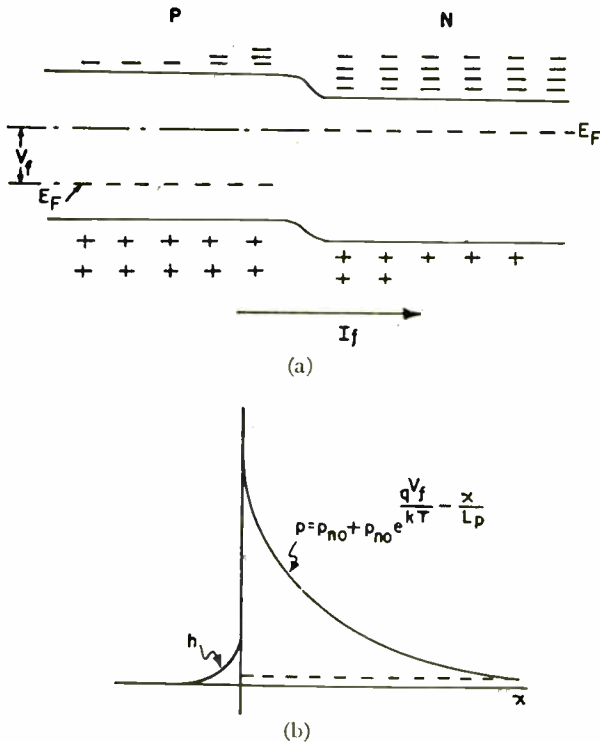

Fig. 2—(a) Energy bands; and (b) Minority-carrier densities for forward biased p - n junction.

current across the barrier. If the term p_{n0} in Fig. 2, b is neglected, the behavior of the hole density and space-charge potential may be represented as in Fig. 3.

Between $t=0$ and T_1 , a constant current, $I_r = V_b/R_0$, flows to the left across the barrier; the junction voltage is given by $kT/q \ln p_0/p_{n0}$ plus a small ohmic contribution which is neglected. The hole density, p_0 , at the boundary may be determined as a function of time from a solution of the diffusion equation. (The dashed lines represent the functions used in the solutions below.) At or near T_1 , the hole density approaches zero, V tends toward minus infinity and a new set of conditions now holds. These are that the hole density at the barrier is practically zero, therefore V is now much larger than kT/q and the diffusion current is no longer constant. The behavior of the hole density is now calculated according to this condition, ($p(0)=0$), and $J = -Ddp/dx$ gives the current as a function of time. It might be noted that the electron current at the barrier is neglected throughout the treatment. This assumption is found to be valid since any electron flow must come either from the space charge region or the p -type mate-

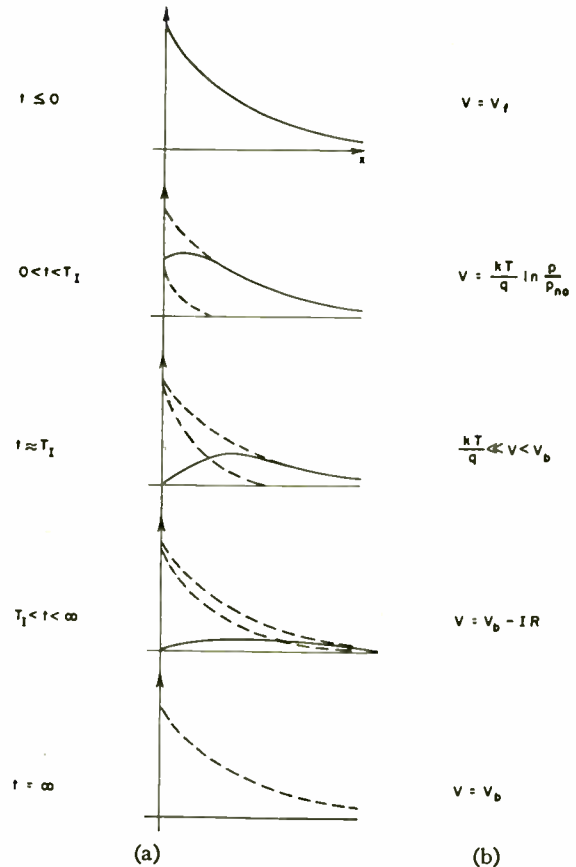

Fig. 3—(a) Hole density, and (b) junction potential, during switching process.

MATHEMATICAL TREATMENT²

Three cases are to be treated mathematically subject to the above criteria. They are the planar diode, the hemispherical diode, and the narrow-base diode. These are represented in Fig. 4 and discussed as treated.

A. Planar Diode

Planar junction with length of n -type material much greater than a diffusion length. (Fig. 4a. $W \gg L_p$.) The diffusion equation

$$\frac{\partial p}{\partial t} = D_p \frac{\partial^2 p}{\partial x^2} - \frac{p}{\tau_p} \tag{1}$$

may be rewritten to read

$$\frac{\partial p}{\partial T} = \frac{\partial^2 p}{\partial X^2} - p \tag{2}$$

² B. Lax and S. F. Neustadter (to be published) have treated the planar junction more rigorously than the treatment to follow, and their results are in good agreement with the approximations used in this paper.

where

$$T = \frac{t}{\tau_p} \quad \text{and} \quad X = \frac{x}{L_p}$$

Since the initial distribution of holes at $t=0$ is a steady-state solution to the diffusion equation; a complete solution may be found by adding to this a new transient solution. The over-all solution for the constant-current phase should satisfy the boundary condition that $J(X=0)$ is constant and equal to $(-J_r) = (-V_b/AR_0)$,

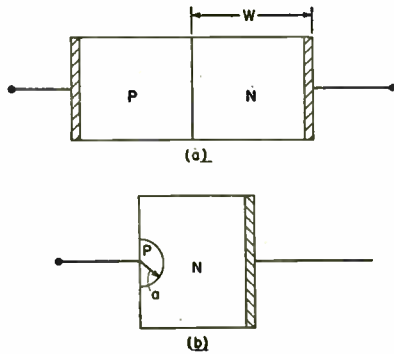

Fig. 4—Junction models used for calculation.

where A is the junction area. Now the current due to the steady state solution is J_f ; therefore, the transient solution should satisfy the diffusion equation and the boundary condition that $J(X=0) = (J_f + J_r)$. When this solution, which we call $p_T(X, T)$ is subtracted from the initial steady-state solution, sketched in Fig. 3, required answer is obtained, since now $J(X=0) = J_f - (J_f + J_r) = -J_r$. By Laplace transformation method³

$$P_T = \frac{(J_f + J_r)L_p}{D_p} I(X, \sqrt{T})$$

where

$$I(x, z) = \frac{\Delta}{\sqrt{\pi}} \int_0^z e^{-u^2} e^{-x/4u^2} du, \quad (3)$$

$$I(0, z) = \text{erf } z$$

and

$$I(x, \infty) = e^{-x}$$

The diode voltage for $0 < T < T_I$ is thus given by

$$V = \frac{kT}{q} \ln \frac{p_0 - p_T(0, T)}{p_{n0}} \quad (4)$$

which is plotted in Fig. 5 for several values of J_r/J_f . As may be seen from the graph the voltage across the space charge region remains of the order of kT/q (0.026 v at room temperature) until a time very near T_I when it decreases very rapidly to minus infinity. It is this low value of voltage up to T_I which validates the assumption of constant current during the first phase of the diode transient. The time, T_I , is found by equating the transient solution at $X=0$, to the steady-state value of

³ See Appendix for a discussion of the mathematical treatment.

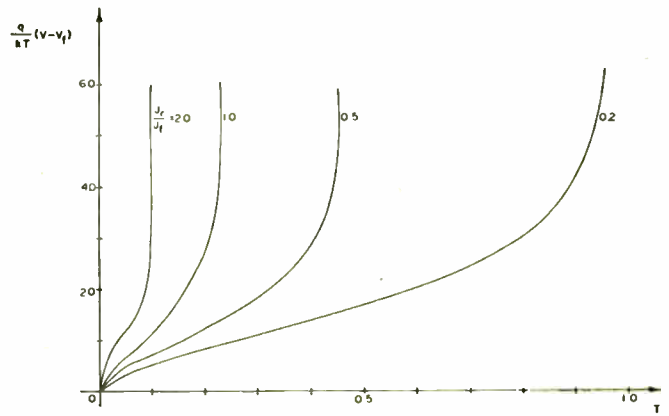

Fig. 5—Junction voltage during constant-current phase.

the hole density, p_0 , giving

$$\text{erf } \sqrt{T_I} = \frac{1}{1 + J_r/J_f} \quad (5)$$

since

$$J_f = \frac{D_p P_0}{L_p} \quad (6)$$

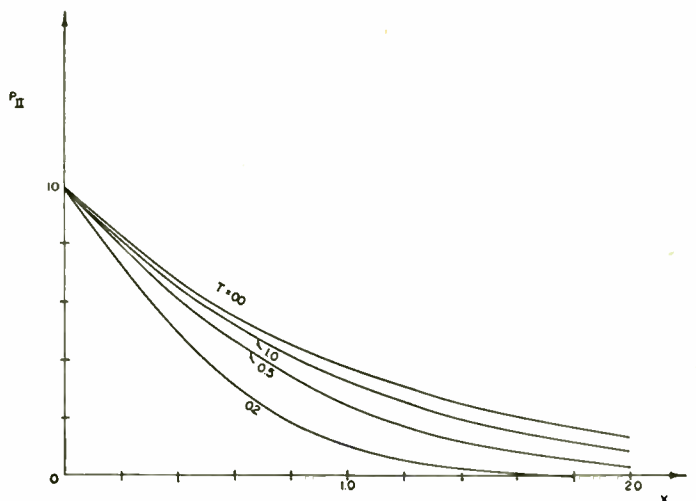
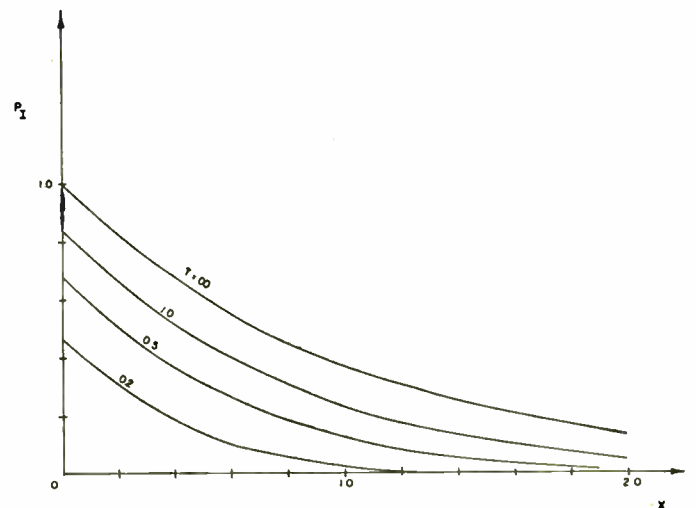

Fig. 6—The functions, p_I and p_{II} , for the planar junction.

For the remainder of the solution, the diffusion equation is solved subject to the boundary condition that $p(X=0)=0$ for all T , or specifically, $p_{II}(0, T)$ is constant and equal to p_0 . This gives

$$p_{II} = \frac{J_f L_p}{D_p} \left[e^{-X} - I \left(X, \frac{X}{2\sqrt{T}} \right) \right] \quad (7)$$

and

$$J_{II} = -D_p \left(\frac{\partial p_{II}}{\partial X} \right)_{X=0} = J_f \left[\operatorname{erf} \sqrt{T} + \frac{e^{-T}}{\sqrt{\pi T}} \right]. \quad (8)$$

For the complete solution of the problem, p_{II} when $J_{II} = (J_f + J_r)$ is assumed to equal p_I at $T = T_I$. Actually, the magnitude and slope of p_I and p_{II} at $(X=0)$ are set equal at the end of the constant-current phase. Fig. 6 shows the normalized functions from which it may be

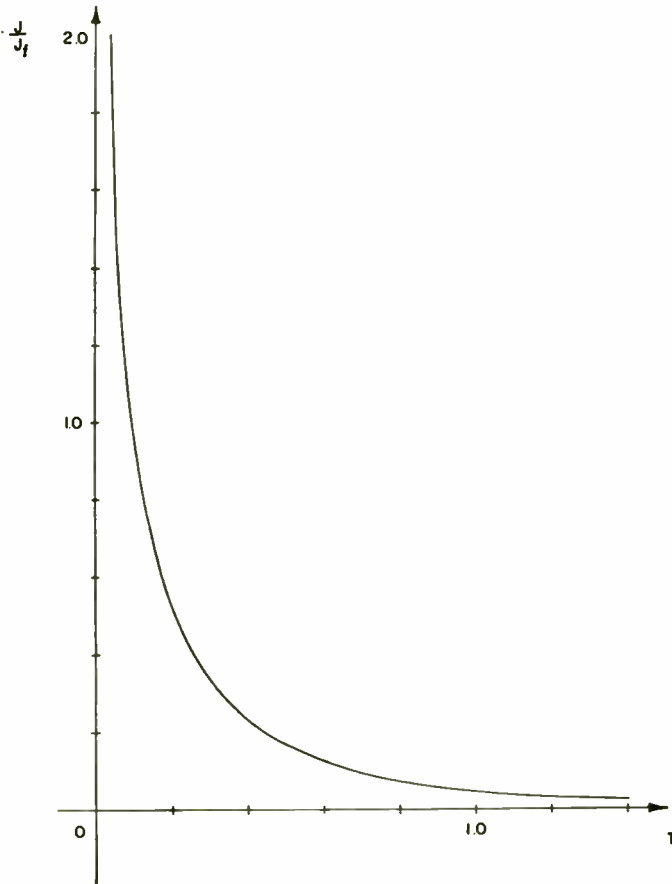

Fig. 7.—Junction reverse current after $T = T_I$.

seen that the above approximation is reasonable. If the true diffusion current $(J_{II} - J_f)$ is now plotted⁴ as in Fig. 7, the reverse current after $T = T_I$ is given by this curve starting at $J = J_r$. The current previous to this time is, of course, J_r , from $T = 0$ to $T = T_I$. (Note that

⁴ This particular equation has been derived previously by Lax and Neustadter, op. cit.; R. G. Shulman and M. E. McMahon, "Recovery currents in germanium $p-n$ junction diodes," paper presented at the AIEE Winter General Meeting, New York, N. Y., January 20, 1953, also *Jour. Appl. Phys.*, vol. 24, p. 1267, 1953; and E. M. Pell, "Recombination rate in germanium by observation of pulsed reverse characteristics," *Phys. Rev.*, vol. 90, p. 228; 1953.

the time scale may be shifted in the two functions p_I and p_{II} .)

B. Hemispherical Diode

Semi-infinite n -type material. (Fig. 4b) The diffusion equation in spherical co-ordinates becomes

$$\frac{\partial u}{\partial T} = \frac{\partial^2 u}{\partial R^2} - u \quad (9)$$

where $u = rp$, $R = r/L_p$, and $T = t/\tau_p$. The solution for the first phase is then

$$p_I = \frac{(J_f + J_r)}{D_p} \left\{ \frac{A^2}{A^2 - 1} I(R - A, \sqrt{T}) + \frac{A}{A^2 - 1} \left[e^{T(1/A^2 - 1)} e^{(R-A)/A} \operatorname{erfc} \left(\frac{R - A}{2\sqrt{T}} + \frac{\sqrt{T}}{A} \right) + I \left(R - A, \frac{R - A}{2\sqrt{T}} \right) - I(R - A, \infty) \right] \right\} \quad (10)$$

where $A = a/L_p$. Now the forward current is given by

$$J_f = \frac{D p_0}{L_p} \left(\frac{L_p}{a} + 1 \right) \quad (11)$$

therefore, at $R = A$, the hole density becomes zero when $p_{II} = p_0$ or

$$\frac{1}{1 + J_r/J_f} = \frac{A}{A - 1} \operatorname{erf} \sqrt{T} + \frac{1}{1 - A} \left[1 - e^{T(1 - A^2/A^2)} \operatorname{erfc} \left(\frac{\sqrt{T}}{A} \right) \right]. \quad (12)$$

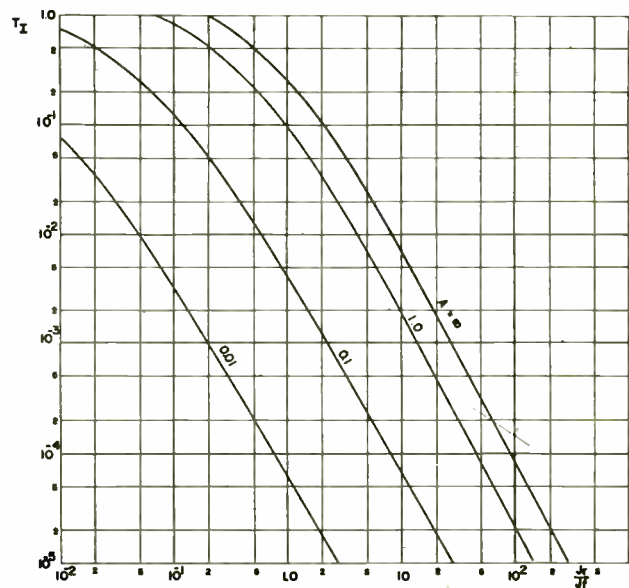

Fig. 8—Storage time, T_I , as a function of A and J_r/J_f .

This relationship is plotted in Fig. 8, which also gives the storage time for the planar case if A is set equal to infinity. The transient solution for the decaying phase is determined as in the linear case giving

$$p_{II} = p_0 \frac{a}{r} \left[I(R - A, \infty) - I\left(R - A, \frac{R - A}{2\sqrt{T}}\right) \right] \quad (13)$$

and

$$J_{II} = \frac{D_p p_0}{a} + \frac{D_p p_0}{L_p} \left[\operatorname{erf} \sqrt{T} + \frac{1}{\sqrt{\pi T}} e^{-T} \right]. \quad (14)$$

Subtracting J_f from the above equation gives the net diode reverse current

$$J_{II} - J_f = \frac{A}{A + 1} \left[\operatorname{erf} \sqrt{T} - 1 + \frac{1}{\sqrt{\pi T}} e^{-T} \right] \quad (15)$$

after use of (11). This is exactly the same equation as that plotted in Fig. 7, after multiplication by the factor $A/(A+1)$, and the method of determining the decay current is as in the previous solution. Fig. 9 shows the general curve for the decay time during the second phase as a function of the current ratio, J_r/J_f , and the radius of the contact, $A = a/L_p$. Here the decay time is defined as that in which the current falls from J_r to 10 per cent of J_r . This is the same time as that required for the diode-voltage to reach 90 per cent of the battery value.

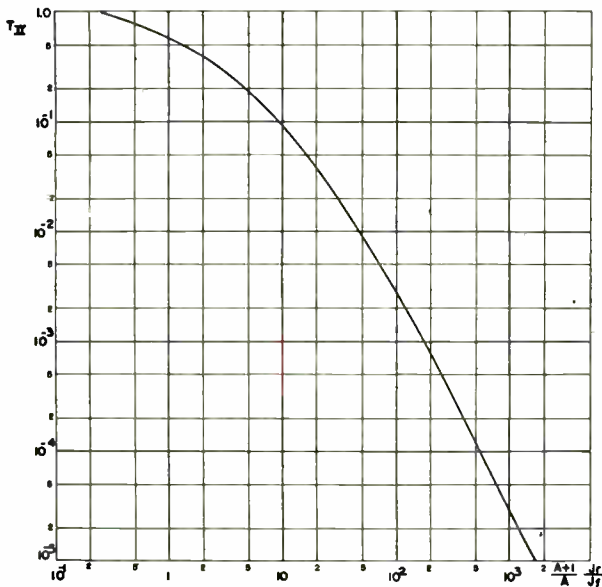

Fig. 9—Decay time, T_{II} , as a function of A and J_r/J_f .

C. Narrow-Base Diode

Width of n -type material, W ; lifetime assumed infinite. (Fig. 4a. $W \ll L_p$.)

Here the boundary conditions will be slightly different than the two preceding treatments. If the ohmic contact to the diode is assumed to be a sink for holes the hole density at $x = W$ must be zero at all times. This is not generally true for all diode contacts but the calculation will be made on this basis since it is directly applicable to the junction transistor where the collector junction is, almost by definition, a sink for holes.

The diffusion equation may be modified to read:

$$\frac{\partial p}{\partial T} = \frac{\partial^2 p}{\partial X^2} \quad (16)$$

where $T = D_p t/W^2$ and $X = x/W$. By the previous methods the constant-current phase solution is found to be

$$p_I = \frac{(J_f + J_r)W}{D} \left(\frac{2}{\pi^2} \right) \sum_{n=0}^{\infty} \frac{(-1)^n (1 - e^{-\pi^2 T (n+1/2)^2})}{(n + \frac{1}{2})^2} \cdot \sin \pi(n + \frac{1}{2})(1 - X) \quad (17)$$

and the solution for the decaying phase with the hole-density constant at $X = 0$, is

$$P_{II} = \frac{J_f W}{D} \left[1 - X + \frac{2}{\pi} \sum_{n=1}^{\infty} \frac{(-1)^n e^{-\pi^2 n^2 T}}{n} \cdot \sin \pi n(1 - X) \right]. \quad (18)$$

These solutions are similar to those plotted in Fig. 6 except that they vanish at $X = 1$. The net decay current at the barrier and at the collector or ohmic contact, ($X = W$), is plotted in Fig. 10.

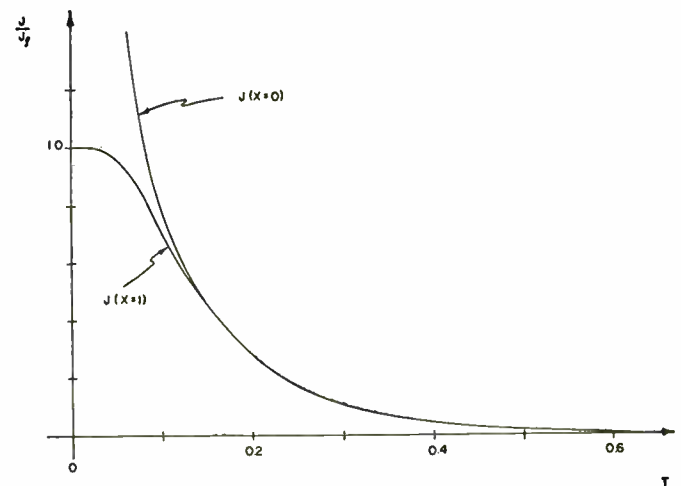

Fig. 10—Net current flow during decaying-current phase (narrow-base).

The decay time T_{II} , defined as before, is plotted in Fig. 11 with the constant-current phase time, T_I . Also shown on the same plot is T_C , which is the time required for the collector current in a junction transistor, $(J_{II}(W) - J_f)$, to fall to 10 per cent of J_f , the initial collector current, after the emitter is switched from forward to reverse. The time, T_C , includes the time, T_I , for the constant-current phase. For $J_r/J_f \ll 1$, T_C is obtained from the equation

$$J_I(W) = (J_f + J_r) \left[1 - \frac{2}{\pi} \sum_{n=0}^{\infty} \frac{(-1)^n e^{-\pi^2 T (n+1/2)^2}}{(n + \frac{1}{2})} \right] \quad (19)$$

which is the transient current at $X = W$ for the constant-current phase.

DISCUSSION OF RESULTS

The calculations for the planar diode are seen to be a special case of the hemispherical diode with an infinite radius of curvature. Most interesting in the resultant curves is the rapid decrease of the storage times, T_I and T_{II} , with decreasing junction radius. It should be

emphasized that these calculations really give an upper limit on the switching times, since, as the radius decreases, the current density, in practical cases becomes so large that the recombination near the junction is no longer linear. The net result of this conductivity modulation should be a decrease in the effective lifetime caused by the large increase in majority carrier density required to neutralize the excess minority carriers. This does not mean that the optimum over-all design results are obtained with the smallest possible junction radius. It should be remembered that forward direction spreading resistance will increase not only with decreasing radius but also with decreasing lifetime, since effective radius for spreading resistance calculation is of the order of the junction radius plus diffusion length.

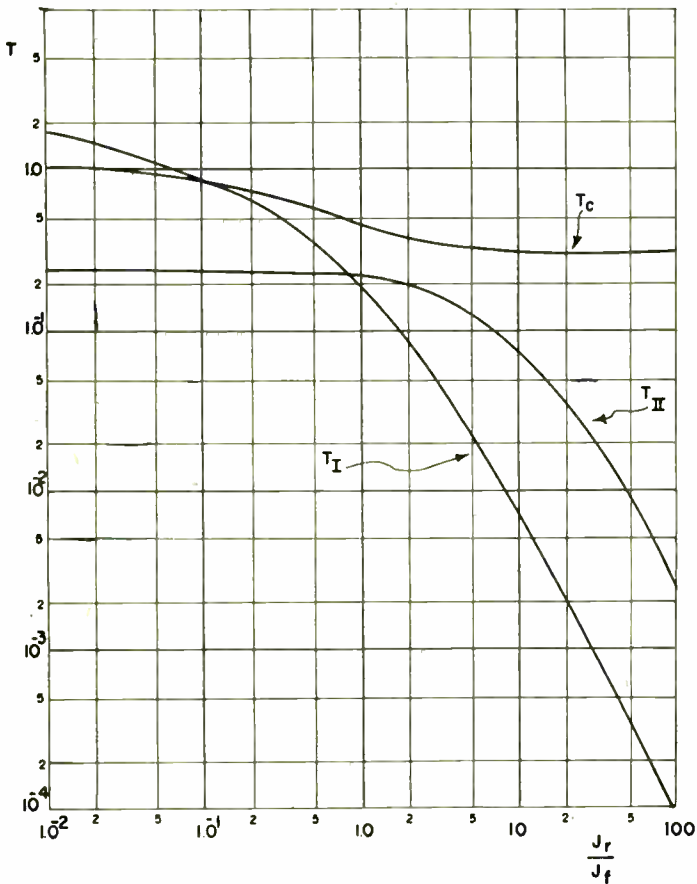

Fig. 11—Time constants, T_I , T_{II} , and T_C , for the narrow-base diode and junction transistor.

The resultant curves for the narrow-base diode are quite similar to the linear diode except for the scale. The normalized parameter, T , which was based on the lifetime in the first two cases is now based on the width of the semiconductor body. In fact, when considering the junction transistor application, the time variable may be written as

$$T = \frac{Dt}{W^2} = \left(\frac{D}{\pi W^2} \right) \pi t = \pi f_{co} t \quad (20)$$

where f_{co} is the frequency cutoff for α as calculated from

the diffusion equation.⁵ In this connection, it should be remembered that the T_C curves give the behavior of the current source αI_e , while the actual collector voltage will also be a function of the collector impedance. Similarly, if the time constant of reverse emitter capacitance and circuit resistance is comparable to calculated switching time of emitter, solution is no longer accurate.

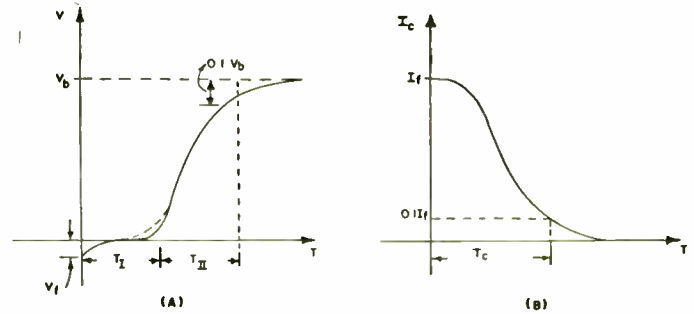

Fig. 12—Switching transients in junction diodes and transistors.

CONCLUSION

The voltage, V_D , across the diode in Fig. 1 will behave as shown in Fig. 12(a), where the times indicated are shown in Figs. 8, 9, and 11. If the diode is the emitter of a junction transistor, then the collector current will behave as in Fig. 11(b) where T_C is given in Fig. 10. The ratio J_r/J_f is also equal to $V_B/I_f R_0$.

ACKNOWLEDGMENT

The mathematical treatment was aided by the contributions of J. Keilson, S. F. Neustadter, G. C. Hunt, and the computing group of this laboratory. Of especial value were the suggestions and encouragement of E. Rawson, B. Lax, J. E. Thomas, and R. B. Adler.

APPENDIX

Mathematical Methods

The solution of the diffusion equation for the different boundary conditions was obtained by Laplace transformation in the time domain and solution of the resultant equation by standard techniques. For the linear and hemispherical diodes the appropriate inverse transforms were found in Magnus and Oberhettinger,⁶ and Hameister.⁷ The transforms for the narrow-base diode are again in Magnus and Oberhettinger.⁶

The integral of (3) of the text may be written

$$I(x, z) = \frac{\sqrt{\pi}}{4} \left[e^{-x} \operatorname{erfc} \left(\frac{x}{2z} - z \right) - e^x \operatorname{erfc} \left(\frac{x}{2z} + z \right) \right].$$

S. F. Neustadter of this laboratory is responsible for this form.

⁵ W. Shockley, M. Sparks and G. K. Teal, "P-n junction transistors," *Phys. Rev.*, vol. 83, p. 151; 1951.

⁶ W. Magnus and F. Oberhettinger, "Formulas and Theorems for the Special Functions of Mathematical Physics," Chelsea Pub. Co., New York, N. Y., p. 129 and p. 136; 1949.

⁷ E. Hameister, "Laplace Transformation," Verlag von R. Oldenbourg, Munich and Berlin, Germany, p. 136; 1943.

Bounds Existing on the Time and Frequency Responses of Various Types of Networks*

ARMEN H. ZEMANIAN†, ASSOCIATE, IRE

Summary—The transient response of fixed, lumped, linear, and stable networks is investigated and many bounds are shown to exist on the impulse and step responses of various classes of system functions. Conversely, if the impulse response is restricted in certain ways, bounds must then exist on the frequency response. These bounds, which are obtained by manipulating the Fourier transforms, have many practical implications. For instance, the response due to a unit impulse of current on a passive driving point impedance which has a shunting capacity, C , across its input terminals is bounded by $\pm(1/C)$ and the rise time for a low pass system of this form must be greater than rC where r equals the value of the impedance under dc conditions. Similar statements may be made for transfer functions satisfying certain mathematical restrictions. As other examples, more severe lower bounds have been found on the settling time for such systems. Also the overshoot or undershoot of the response to a step input of current for an RC driving point impedance cannot be greater than one hundred per cent.

INTRODUCTION

IT IS A WELL KNOWN fact that linear networks cannot have arbitrary frequency characteristics.¹ For the case of minimum reactance or susceptance networks, many relations have been found between the real and imaginary parts of the system immittance and similar relations exist between the amplitude and phase functions in the minimum phase case. The positive real characteristic of a driving point immittance is another such example. The object of this investigation has been to discover an analogous set of restrictions on the time response of various types of networks.

The results in general indicate that the impulse and unit step responses of various classes of networks are bounded in many ways and, due to the reciprocal nature of the direct and inverse Fourier transforms, similar restrictions which may be placed on the time responses fix bounds on the corresponding frequency responses. These bounds which are defined in the forthcoming theorems, are not approximate relations but definite restrictions that the responses of the appropriate systems must obey.

A special case of theorem one has appeared previously. M. Nadler² formulates a similar problem mathematically and points out that, for a two-terminal, low-pass, passive network which has a certain amount of

shunting capacity, C , between its terminals, the rise time from zero to the final value cannot be less than rC where r is the final value. It has been found in this investigation that such a restriction can be applied to any system function which satisfies a few mathematical conditions and furthermore a number of theorems of this type are proven. Finally it should be pointed out that some of these results and methods have analogies in probability theory and, in particular, to the conditions on the characteristic functions.^{3,4}

SOME THEOREMS CONCERNING TIME AND FREQUENCY RESPONSES

The Applicability of the Theorems

In the forthcoming discussion it is assumed that a unit step or impulse of current is impressed upon the network and a corresponding voltage response is taken as the output so that the system function is an impedance. However these theorems apply just as well if the input is a voltage, the output a current, and the system function an admittance. Similarly both input and output may be voltages or currents and the system function a transfer function.

Furthermore it is assumed that the input is applied at time, $t=0$, so that the unit impulse response, $W(t)$, and the unit step response, $A(t)$, are identically equal to zero for negative values of time. Also the systems are taken to be fixed, lumped, linear, and stable networks such that the system impedance, $Z(s) = N(s)/D(s)$, has no poles on the real frequency axis or in the right half plane. The real and imaginary parts of $Z(j\omega)$ are represented by the symbols $R(\omega)$ and $I(\omega)$, respectively.

Finally only those system impedances are considered for which the polynomial, $D(s)$, is of degree equal to or greater than the degree of the polynomial, $N(s)$. This restriction is needed to insure the convergence of certain integrals which will arise in the forthcoming proofs. Thus the system impedance may be expanded into the following two infinite series:

$$Z(s) = K + \frac{1}{Cs} + \frac{K_2}{s^2} + \frac{K_3}{s^3} + \dots; \quad |s| \geq p$$

$$Z(s) = r + k_1s + k_2s^2 + k_3s^3 + \dots; \quad |s| \leq q.$$

Since these expansions will only be of interest around the origin and as s approaches infinity, let p be a number

* Decimal classification: R143. Original manuscript received by the IRE, July 13, 1953; revised manuscript received, December 16, 1953.

This paper is based on a portion of a thesis which has been accepted by the faculty of the Graduate Division, College of Engineering, New York University, in partial fulfillment of the requirements for the degree of Doctor of Engineering Science.

† Elec. Eng. Dept., New York University, New York, N. Y.

¹ H. W. Bode, "Network Analysis and Feedback Amplifier Design," D. Van Nostrand Co., New York, N. Y., 1st ed., chap. 13; 1945.

² M. Nadler, "Letter to the editor," PROC. I.R.E., vol. 38, p. 441; April, 1950.

³ H. Cramér, "Random Variables and Probability Distributions," Cambridge Tracts in Mathematics and Mathematical Physics, Cambridge University, London, Eng., no. 36; 1937.

⁴ H. Cramér, "Mathematical Methods of Statistics," Princeton University Press, 1st ed., chap. 10; 1946.

greater than one and also greater than the distance from the origin to the pole of $Z(s)$ furthest from the origin and let q be a number less than one and also less than the distance from the origin to the pole nearest the origin. In the forthcoming theorems, designating a system impedance by the symbol, $Z(s)$, or its corresponding unit impulse response by the symbol, $W(t)$, will mean that the system satisfies the foregoing restrictions.

The Development of the Theorems

Theorem 1: If $Z(s)$ is such that $K=0$ and $R(\omega) \geq 0$ for all ω , then $W(t) \leq (1/C)$.

Note: For a passive driving point impedance, the symbol, C , would represent the shunting capacity between the input terminals if there were no other purely capacitive path through the network. Also K is stipulated to be zero so that $\int_0^\infty R(\omega) d\omega$ converges.

Proof: The Fourier transform which relates the impulse response to the real part of the system function is given as follows:⁵

$$W(t) = \frac{2}{\pi} \int_0^\infty R(\omega) \cos \omega t d\omega. \quad (1)$$

Since $R(\omega)$ is never negative, by hypothesis:

$$|W(t)| = \left| \frac{2}{\pi} \int_0^\infty R(\omega) \cos \omega t d\omega \right| \leq \frac{2}{\pi} \int_0^\infty R(\omega) d\omega.$$

Now by integrating $Z(s)$ around the right half s plane and making use of the fact that there are no poles in the right half s plane nor on the $j\omega$ axis, a value may be obtained for $\int_0^\infty R(\omega) d\omega$.¹ Thus:

$$\frac{2}{\pi} \int_0^\infty R(\omega) d\omega = \frac{1}{C}.$$

This completes the proof.

Theorem 2: If $Z(s)$ is such that $K=0$ and $(dR/d\omega) \leq 0$ for $0 \leq \omega$ then $|W(t)| < (2r/\pi t)$ and $|W(t)| \leq (1/C)$.

Proof: Since $\int_0^\infty R(\omega) d\omega = \pi/2C$, $R(\omega)$ vanishes as ω increases beyond all bound. Thus the condition that $(dR/d\omega) \leq 0$ for $0 \leq \omega$ requires that $r \geq R(\omega) \geq 0$ for $0 \leq \omega$, the system being a lumped, linear, fixed, and stable one. Thus theorem one may be invoked.

The second part of the proof is based upon expression obtained by integrating transform (1) by parts.

$$W(t) = -\frac{2}{\pi t} \int_0^\infty \frac{dR}{d\omega} \sin \omega t d\omega.$$

Since $(dR/d\omega) \leq 0$ for $0 \leq \omega$:

$$|W(t)| < -\frac{2}{\pi t} \int_0^\infty \frac{dR}{d\omega} d\omega = \frac{2r}{\pi t}.$$

This completes the proof.

Theorem 3: If $Z(s)$ is such that $I(\omega) \leq 0$ for $0 \leq \omega$, then:

$$K \leq A(t) < 2r - K.$$

Note: If $r=0$ and if $I(\omega) \geq 0$ then a similar theorem may be proved which states that $|A(t)| \leq K$.

Proof: Use is made of the following Fourier transform:

$$A(t) = \frac{2}{\pi} \int_0^\infty \frac{I(\omega)}{\omega} \cos \omega t d\omega + r. \quad (2)$$

As before:

$$\left| \int_0^\infty \frac{I(\omega)}{\omega} \cos \omega t d\omega \right| \leq \int_0^\infty \frac{|I(\omega)|}{\omega} d\omega.$$

Again by integrating $Z(s)/s$ around the right half s plane, a value may be obtained for $\int_0^\infty [|I(\omega)|/\omega] d\omega$. In this case, however, the path of integrating must be indented slightly to the right of the pole that exists at the origin.¹ Thus:

$$\int_0^\infty \frac{|I(\omega)|}{\omega} d\omega = \frac{\pi}{2} (r - K).$$

Furthermore since $\int_0^\infty [|I(\omega)|/\omega] d\omega$ is a positive quantity, $r \geq K$. Thus:

$$K \leq A(t) < 2r - K$$

and the proof is thereby complete.

By placing similar restrictions on the impulse response, bounds may be found on the frequency functions as follows.

Theorem 4: If $W(t)$ is such that $\int_0^\infty W(t) dt = r$ and $W(t) \geq 0$ for all t , then $|Z(j\omega)| \leq r$, $|R(\omega)| \leq r$ and $|I(\omega)| < r$ for all ω .

Note: Stating that $\int_0^\infty W(t) dt = r$ is the same as stating that $K=0$. For if K were not zero, the impulse response would have a singularity at $t=0$ and this integral would not exist.

The proof of this theorem is the same as that of theorem one wherein use is made of the following Fourier integrals.⁵

$$Z(j\omega) = \int_{-\infty}^\infty W(t) e^{-i\omega t} dt. \quad (3)$$

$$R(\omega) = \int_0^\infty W(t) \cos \omega t dt. \quad (4)$$

$$I(\omega) = -\int_0^\infty W(t) \sin \omega t dt. \quad (5)$$

If the first derivative of the impulse response is never positive then a theorem similar to theorem two may be constructed for these frequency functions. Similarly if the second derivative is never negative then a set of three bounds may be found on each of these functions. The general case where the m th derivative of $W(t)$ is never negative or never positive is stated by Theorem 5. The proof of this theorem makes use of the expressions which are obtained by repeatedly integrating the expressions (3), (4), and (5) by parts, and inserting the appropriate initial and final values bearing in mind that $W(t)$ must vanish as t goes to infinity for these expressions to hold. The derivatives of $W(t)$ at $t=0$ are taken

⁵ E. A. Guillemin, "Communications Networks," John Wiley & Sons, New York, N. Y., 1st ed., vol. II, chap. 11; 1935.

to be the limiting values that these derivatives approach as t goes to zero through positive values. From expression 3:

$$Z(j\omega) = \sum_{k=0}^n \frac{1}{(j\omega)^{k+1}} \left. \frac{d^k W}{dt^k} \right]_{t=0} + \frac{1}{(j\omega)^{n+1}} \int_0^\infty \frac{d^{n+1} W}{dt^{n+1}} e^{-i\omega t} dt. \quad (6)$$

From expression 4:

$$R(\omega) = \sum_{k=1}^n \frac{(-1)^k}{\omega^{2k}} \left. \frac{d^{2k-1} W}{dt^{2k-1}} \right]_{t=0} + \text{remainder} \quad (7)$$

$$\begin{aligned} \text{where the remainder} &= \frac{(-1)^n}{\omega^{2n}} \int_0^\infty \frac{d^{2n} W}{dt^{2n}} \cos \omega t dt \\ &= \frac{(-1)^{n+1}}{\omega^{2n+1}} \int_0^\infty \frac{d^{2n+1} W}{dt^{2n+1}} \sin \omega t dt. \end{aligned}$$

From expression 5:

$$I(\omega) = \sum_{k=0}^n \frac{(-1)^{k+1}}{\omega^{2k+1}} \left. \frac{d^{2k} W}{dt^{2k}} \right]_{t=0} + \text{remainder} \quad (8)$$

$$\begin{aligned} \text{where the remainder} &= \frac{(-1)^{n+1}}{\omega^{2n+1}} \int_0^\infty \frac{d^{2n+1} W}{dt^{2n+1}} \cos \omega t dt \\ &= \frac{(-1)^{n+2}}{\omega^{2n+2}} \int_0^\infty \frac{d^{2n+2} W}{dt^{2n+2}} \sin \omega t dt. \end{aligned}$$

Theorem 5: If $W(t)$ is such that $\int_0^\infty W(t) dt = r$ then, when the m th derivative is never positive or never negative, the following set of bounds hold where $n = 1, 2, 3, \dots, m$.

$$\begin{aligned} |Z(j\omega)| &\leq \left| \sum_{k=0}^{n-1} \frac{1}{(j\omega)^{k+1}} \left. \frac{d^k W}{dt^k} \right]_{t=0} \right| \\ &+ \left| \frac{2}{(j\omega)^{n+1}} \left. \frac{d^n W}{dt^n} \right]_{t=0} \right|. \quad (9) \end{aligned}$$

If the $2m$ th derivative of $W(t)$ is never negative then the following set of bounds hold where $n = 1, 2, 3, \dots, m$.

$$\begin{aligned} \sum_{k=1}^n \frac{(-1)^k}{\omega^{2k}} \left. \frac{d^{2k-1} W}{dt^{2k-1}} \right]_{t=0} - \left| \frac{1}{\omega^{2n}} \left. \frac{d^{2n-1} W}{dt^{2n-1}} \right]_{t=0} \right| &\leq R(\omega) \\ \leq \sum_{k=1}^n \frac{(-1)^k}{\omega^{2k}} \left. \frac{d^{2k-1} W}{dt^{2k-1}} \right]_{t=0} + \left| \frac{1}{\omega^{2n}} \left. \frac{d^{2n-1} W}{dt^{2n-1}} \right]_{t=0} \right|. \quad (10) \end{aligned}$$

$$\begin{aligned} \sum_{k=0}^n \frac{(-1)^{k+1}}{\omega^{2k+1}} \left. \frac{d^{2k} W}{dt^{2k}} \right]_{t=0} - \frac{1}{\omega^{2n+1}} \left. \frac{d^{2n} W}{dt^{2n}} \right]_{t=0} &\leq I(\omega) \\ \leq \sum_{k=0}^n \frac{(-1)^{k+1}}{\omega^{2k+1}} \left. \frac{d^{2k} W}{dt^{2k}} \right]_{t=0} + \frac{1}{\omega^{2n+1}} \left. \frac{d^{2n} W}{dt^{2n}} \right]_{t=0}. \quad (11) \end{aligned}$$

And if the $(2m+1)$ th derivative of $W(t)$ is never positive then the following set of bounds hold where $n = 1, 2, 3, \dots, m$.

$$\sum_{k=1}^n \frac{(-1)^k}{\omega^{2k}} \left. \frac{d^{2k-1} W}{dt^{2k-1}} \right]_{t=0} - \frac{1}{\omega^{2n+1}} \left. \frac{d^{2n} W}{dt^{2n}} \right]_{t=0} < R(\omega)$$

$$< \sum_{k=1}^n \frac{(-1)^k}{\omega^{2k}} \left. \frac{d^{2k-1} W}{dt^{2k-1}} \right]_{t=0} + \frac{1}{\omega^{2n+1}} \left. \frac{d^{2n} W}{dt^{2n}} \right]_{t=0}. \quad (12)$$

$$\begin{aligned} \sum_{k=0}^n \frac{(-1)^{k+1}}{\omega^{2k+1}} \left. \frac{d^{2k} W}{dt^{2k}} \right]_{t=0} - \left| \frac{1}{\omega^{2n+2}} \left. \frac{d^{2n+1} W}{dt^{2n+1}} \right]_{t=0} \right| &< I(\omega) \\ < \sum_{k=0}^n \frac{(-1)^{k+1}}{\omega^{2k+1}} \left. \frac{d^{2k} W}{dt^{2k}} \right]_{t=0} + \left| \frac{1}{\omega^{2n+2}} \left. \frac{d^{2n+1} W}{dt^{2n+1}} \right]_{t=0} \right|. \quad (13) \end{aligned}$$

Proof: The proof of this theorem proceeds in the same way as the proofs of the previous ones. Expression (9) is obtained from (6), expressions (10) and (12) are obtained from (7), and expressions (11) and (13) are obtained from (8). Then the specification of any even derivative as never negative or any odd derivative as never positive designates all the lower even derivatives as never negative and all the lower odd derivatives as never positive. Thus all the lower ordered bounds also hold and the proof is therefore complete.

These derivatives need not be never-negative or never-positive for bounds of this nature to hold. For instance, assuming that the magnitude of the n th derivative of $R(\omega)$ is integrable over the semi-infinite range, then the corresponding bound on the impulse response is of the form:

$$|W(t)| \leq \frac{\text{constant}}{t^n}.$$

Finally by stipulating $R(\omega)$ as never-negative for $0 \leq \omega$ and assuming that the impulse response dies out to within certain limits after a period of time, bounds on the impulse response stronger than the one given by theorem one may be found.

Theorem 6: If $R(\omega) \geq 0$ for all ω and if $|W(t)| \leq (\epsilon/C) < (1/C)$ for $t_e \leq t$ and $W(0) = 1/C$, then $|W(t)|$ lies within the following set of bounds.

For

$$\frac{t_e}{2} \leq t < t_e, \quad |W(t)| < (.637 + .638\epsilon) \frac{1}{C}; \quad (14)$$

for

$$\frac{t_e}{3} \leq t < \frac{t_e}{2}, \quad |W(t)| < (.785 + 1.916\epsilon) \frac{1}{C}; \quad (15)$$

for

$$\frac{t_e}{4} \leq t < \frac{t_e}{3}, \quad |W(t)| < (.907 + .493\epsilon) \frac{1}{C}; \quad (16)$$

and for

$$0 \leq t < \frac{t_e}{4}, \quad |W(t)| \leq \left[1 - \frac{t^2}{4t_e^2} (1 - \epsilon) \right] \frac{1}{C}. \quad (17)$$

Note: These bounds are illustrated in Fig. 1, following page, for a negligible ϵ .

Proof: Consider the following inequality which holds since $R(\omega) \geq 0$ by hypothesis:

$$|W(t)| \leq \frac{2}{\pi} \int_0^\infty R(\omega) |\cos \omega t| d\omega. \quad (18)$$

Inserting the inequality:

$$|\cos \omega t| \leq \frac{3}{4} + \frac{1}{4} \cos 2\omega t$$

and integrating, the following is obtained:

$$|W(t)| \leq \frac{3}{4} \cdot \frac{1}{C} + \frac{1}{4} |W(2t)|.$$

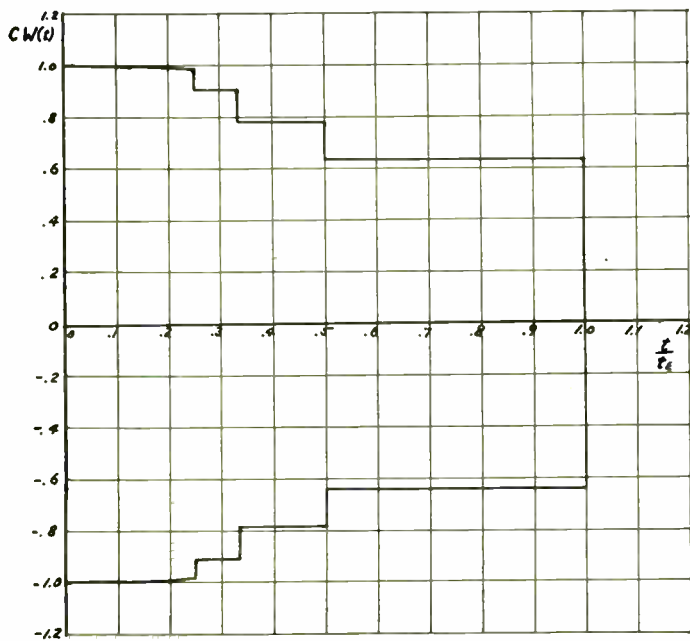

Fig. 1—Illustration of the bounds defined in Theorem 6 for a negligible ϵ .

However, for

$$\frac{t_e}{2} \leq t < t_e, \quad |W(2t)| \leq \frac{\epsilon}{C}.$$

So:

$$|W(t)| < \frac{1}{C} \left[1 - \frac{1}{4} (1 - \epsilon) \right].$$

Repeating the argument n times:

For

$$\frac{t_e}{2^n} \leq t < \frac{t_e}{2^{n-1}}, \quad |W(t)| < \frac{1}{C} \left[1 - \frac{1}{4^n} (1 - \epsilon) \right]. \quad (19)$$

But for

$$t < \frac{t_e}{2^{n-1}}, \quad \frac{1}{4} \cdot \frac{t^2}{t_e^2} < \frac{1}{4^n}$$

so the inequality (19) may be replaced by (20):

$$|W(t)| < \frac{1}{C} \left[1 - \frac{t^2}{4t_e^2} (1 - \epsilon) \right]. \quad (20)$$

Since n is an arbitrary positive integer, this holds for the interval $0 < t < t_e$. Furthermore $W(0) = 1/C$, and so the proof for the bound (17) is complete.

For bounds (14) and (16), the $|\cos \omega t|$ is expanded in a Fourier series and inserted into expression (18).

$$|W(t)| \leq \frac{2}{\pi} \int_0^\infty \left[\frac{2}{\pi} R(\omega) - \frac{4}{\pi} \sum_{n=1}^\infty \frac{(-1)^n}{4n^2 - 1} R(\omega) \cos 2n\omega t \right] d\omega. \quad (21)$$

Since the infinite series in expression (21) converges uniformly it may be integrated term by term. Then the following inequality may be obtained.

$$|W(t)| < \frac{2}{\pi} \left[\frac{1}{C} + 2 \sum_{n=1}^\infty \frac{1}{4n^2 - 1} |W(2nt)| \right].$$

Now for $(t_e/2) \leq t < t_e$ and for $n = 1, 2, 3, \dots$, $|W(2nt)| \leq (\epsilon/C) < (1/C)$. Furthermore:

$$\sum_{n=1}^\infty \frac{1}{4n^2 - 1} < .5010.$$

Thus:

$$|W(t)| < \frac{1}{C} (.637 + .638\epsilon). \quad (14)$$

Similarly it can be shown that, for $(t_e/4) \leq t < (t_e/3)$,

$$|W(t)| < \frac{1}{C} (.907 + .493\epsilon). \quad (16)$$

Finally to develop the bound (15), the $\cos \omega t$ in expression (1) is replaced by $f_1(\omega t)$.

$$f_1(\omega t) = \begin{cases} \cos \omega t & \text{for } 0 \leq \omega t \leq \frac{\pi}{2} \\ -\frac{2}{\pi} x + 1 & \text{for } \frac{\pi}{2} \leq \omega t \leq \pi \end{cases}$$

$$f_1(\omega t) = f_1(-\omega t); \quad f_1(\omega t) = f_1(\omega t + 2\pi).$$

Expanding this into a Fourier series and proceeding exactly as before, the following is obtained:

For

$$\frac{t_e}{3} \leq t < \frac{t_e}{2}, \quad W(t) < \frac{1}{C} (.785 + 1.916\epsilon).$$

To develop a symmetrical set of lower bounds for this interval, the function $g_1(\omega t) = -f_1(\omega t + \pi)$ may be applied in exactly the same way. This completes the proof.

An analogous set of theorems may be constructed on $R(\omega)$, $Z(j\omega)$ and $A(t)$. This has been done and the whole matter is discussed in much greater detail elsewhere.⁶

SOME PHYSICAL INTERPRETATIONS OF THESE THEOREMS

These theorems have practical implications some of which are listed below.

1. The condition that $R(\omega) \geq 0$ for all ω is the characteristic which differentiates passive driving-point impedances from active ones. So the impulse responses of such systems are limited by the bounds in Theorems 1 and 6, for any two terminal network must have some

⁶ A. H. Zemanian, "Investigation of the Transient Response of Linear Systems," New York Univ., Dept. of Elec. Eng., doctoral dissertation, chaps. 3-4; 1953.

stray shunting capacity across its terminals. Furthermore this result means that the slope of the unit-step response cannot be greater than $1/C$ and so the rise time from zero to the final value, r , cannot be less than rC . Nor can the rise time from $0.1r$ to $0.9r$ be less than $0.8rC$. These restrictions hold for any system function which satisfies the conditions of these theorems.

2. From Theorem 3, it can be seen that any RC two terminal network cannot have a percentage overshoot or undershoot in its voltage response to a step input of current greater than one hundred per cent. Furthermore, if the driving point impedance of this RC network assumes a value of K as ω goes to infinity then the percentage overshoot or undershoot must be less than $100(r-K)/r$. It could also be said for the current in an RL network when a voltage source is applied.

3. Theorem 4 yields the result that if $|Z(j\omega)|$ or $|R(\omega)|$ at any angular velocity, $\omega \neq 0$, is greater than its value at $\omega = 0$, then $W(t)$ must be negative at some time. In other words, the unit step response cannot be monotonic increasing. Similarly these frequency responses must satisfy the bounds of Theorem 6 if the unit step response is to be monotonic increasing.

4. Inserting the value, $m=1$, into expression (10) of Theorem 5, it can be seen that any impulse response that vanishes with time, has a finite, nonzero initial value and is always concave upward will have a Fourier transform whose real part is never negative. This fact is of use if one is interested in designing a passive driving-point impedance from prescribed transient behavior.

5. System functions which satisfy the conditions of Theorem 6 will have corresponding step responses whose rise times are greater than the lower bounds mentioned in part one of this section. Similarly if the settling time is defined as follows then even stronger bounds may be constructed for this settling time.

Definition: The "settling time to ϵ ," τ_{se} , is the least time beyond which the step response remains within $r(1-\epsilon)$ of its final value, r , and the impulse response remains within $\epsilon(1/C)$ of its initial value, $1/C$, where ϵ is a positive quantity less than unity. This assumes that the input functions are impressed at time, $t=0$.

It has been shown that for appropriate systems the unit impulse response must remain within the bounds indicated in Theorem 6. Up to time, t_e , the maximum value that the unit step response may attain is the area between the upper set of bounds and the time axis. Moreover, if the time, t_e , from which these bounds are constructed is so taken that the unit step response is always within $|1-\epsilon|r$ of its final value (that is, $t_e = \tau_{se}$) then the maximum final value for a given C and τ_{se} may be calculated. This, in turn, yields a lower bound on τ_{se} for a given r and C .

$$\tau_{se} > \frac{1 - \epsilon}{.774 + .681\epsilon} rC. \tag{22}$$

By extending bound (16) over the interval of bound (15) (this is permissible as can be seen from the proof

of Theorem 6) a stronger lower bound on τ_{se} is obtained for larger ϵ .

$$\tau_{se} > \frac{1 - \epsilon}{.794 + .444\epsilon} rC. \tag{23}$$

Similarly extending bound (14) up to $\tau_{se}/2$:

$$\tau_{se} > \frac{1 - \epsilon}{.808 + .329\epsilon} rC. \tag{24}$$

And finally if the bound (14) is extended up to τ_{se} :

$$\tau_{se} > \frac{1 - \epsilon}{.916 + .0833\epsilon} rC. \tag{25}$$

The strongest lower bound on τ_{se} obtained by combining (22) through (25) in sections is indicated in Fig. 2.

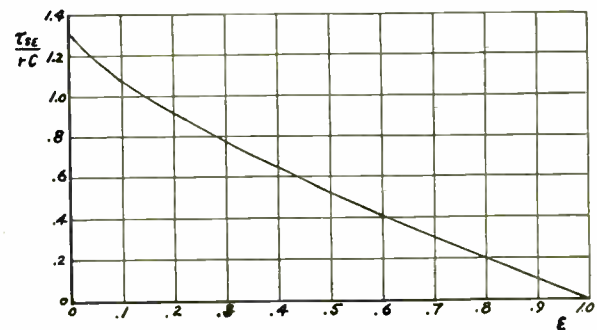

Fig. 2—A lower bound on the settling time to ϵ .

ACKNOWLEDGMENT

The writer is indebted to Professors J. H. Mulligan, Jr., and C. F. Rehberg, of New York University, for the many valuable suggestions and criticisms extended throughout the development of this work.

APPENDIX

Notations and Symbols

- $A(t)$ = the response to a unit step function applied at time, $t=0$.
- C = the capacity existing between the two terminals of a passive driving-point impedance.
- ϵ = a positive real number less than one.
- $I(\omega)$ = the imaginary part of a system function for real frequencies.
- K = the constant multiplier of a system function having an equal number of poles and zeros.
- $r = Z(0)$ = the resistance of a system function under dc conditions.
- $R(\omega)$ = the real part of a system function for real frequencies.
- s = a complex variable.
- t = time.
- τ = time.
- τ_{se} = the settling time to ϵ of the time response of a system as defined in the paper.
- $W(t)$ = the response to a unit impulse function applied at time, $t=0$.
- ω = angular frequency = (2π) (frequency).
- $Z(s)$ = a system impedance.

Matrix Analysis of Multi-Terminal Transducers*

JACOB SHEKEL†, ASSOCIATE, IRE

Summary—A multi-terminal transducer (m.t.t.) is a network with a set of n input terminals and a set of n output terminals. The properties of m.t.t.'s and their representation by matrices are a generalization of four-pole theory.

The m.t.t. is represented by its impedance, admittance or transfer matrices. The special properties of m.t.t.'s that exhibit symmetry, reciprocity or both properties are discussed. The representation is definite or indefinite according to whether the voltage reference terminals are specified or not.

Methods are derived to write down the transfer matrices of given m.t.t.'s. Some simple networks may be analyzed by inspection; more complicated networks may be treated as a cascade of simpler ones

INTRODUCTION

MATRIX ANALYSIS OF linear four-poles has received extensive treatment in the literature,¹⁻⁵ and the references cited are just a few out of a much longer list. The treatment, originally restricted to passive networks obeying the reciprocity relation, was later extended to networks containing vacuum tubes⁶⁻⁸ and gyrators.^{9,10}

A four-pole being a network with one pair of input terminals and one pair of output terminals, there are two obvious ways of generalizing four-pole treatment: first, networks having many pairs of terminals, and second, networks having a set of n input terminals and a set of n output terminals, with $n > 2$. The first generalization occurs in the treatment of branches or junctions in transmission lines.^{11,12} The second generalization is the subject of this paper.

* Decimal classification: R143. Original manuscript received by the IRE, July 7, 1953.

† Haifa, Israel.

¹ E. A. Guillemin, "Communication Network," chap. IV, "Characteristics of four-terminal networks," John Wiley and Sons, Inc., New York, N. Y.; 1935.

² R. Feldtkeller, "Einführung in die Vierpoltheorie der Elektrischer Nachrichtentechnik," Hirzel Verlag, Leipzig, Germany; 1948.

³ L. Brillouin, "Wave Propagation in Periodic Structures," chap. IX, "Matrices and the propagation of waves along an electric line," McGraw-Hill Book Co., Inc., New York, N. Y.; 1946.

⁴ L. A. Pipes, "Applied Mathematics for Engineers and Physicists," chap. X, sec. 14, "Four terminal networks connection with matrix algebra," McGraw-Hill Book Co., Inc., New York, N. Y.; 1946.

⁵ P. I. Richards, "Applications of matrix algebra to filter theory," Proc. I.R.E., vol. 34, p. 145P; March, 1946.

⁶ J. S. Brown and F. D. Bennett, "The application of matrices to vacuum-tube circuits," Proc. I.R.E., vol. 36, p. 844; July, 1948.

⁷ S. R. Deards, "Matrix theory applied to electronic valve circuits," *Electronic Eng.*, vol. 24, p. 264; June, 1952.

⁸ L. C. Peterson, "Equivalent circuits of linear active four-terminal networks," *Bell Sys. Tech. Jour.*, vol. 27, p. 593; October, 1948.

⁹ B. D. H. Tellegen, "The Synthesis of Passive, Resistanceless Four-Poles that May Violate the Reciprocity Relation," Phillips Res. Rep., Eindhoven, Netherlands, vol. 3, p. 321; October, 1948.

¹⁰ B. D. H. Tellegen and E. Klauss, "The Parameters of a Passive Four-Pole that May Violate the Reciprocity Relation," Phillips Res. Rep., Eindhoven, Netherlands, vol. 5, p. 81; April, 1950.

¹¹ C. G. Montgomery, R. H. Dicke, and E. M. Purcell, "Principles of Microwave Circuits," Radiation Laboratory Series No. 8, McGraw-Hill Book Co., Inc., New York, N. Y.; 1948.

¹² N. Marcuvitz, "Waveguide Handbook," Radiation Laboratory Series No. 10, McGraw-Hill Book Co., Inc., New York, N. Y.; 1951.

A network with n input terminals and n output terminals, with a one-one correspondence between both sets of terminals, will be termed an n -terminal transducer. A four-pole is thus a 2-terminal transducer. Some examples of multi-terminal transducers (henceforth abbreviated to m.t.t.) are: sections of multiwire transmission lines, sections of a distributed amplifier, or sections of coupled transmission lines.

M.t.t.'s have been treated by Rice,¹³ using matrix theory. Our approach is different from Rice's in the following points, which make the discussion more general.

1. The discussion is not restricted to networks that obey the reciprocity relation.
2. In the paper by Rice, "the leads marked 0 play a special role in that all the voltages are measured with respect to them, and the currents which they carry are the sum of the currents flowing into or out of the remaining terminals."¹⁴ The treatment outlined in this paper enables any terminal to be specified as ground terminal, or even to leave the ground terminal unspecified.
3. Methods are derived to write down the matrices of given networks by inspection, similar to those of ordinary four-poles.⁵

For the sake of completeness some of the results due to Rice are included.

The reader is referred to any standard textbook¹⁵ for the explanation of matrix manipulations. The following notations will be employed:

Square or rectangular matrices will be denoted by bold-face capitals: \mathbf{Y} ; column matrices by bold-face lower case letters: \mathbf{v} . The submatrices of partitioned matrices will be denoted by subscripts

$$\mathbf{Y} = \begin{bmatrix} \mathbf{Y}_{11} & \mathbf{Y}_{12} \\ \mathbf{Y}_{21} & \mathbf{Y}_{22} \end{bmatrix}, \quad \mathbf{v} = \begin{bmatrix} v_1 \\ v_2 \end{bmatrix},$$

except in one case where, because of their repeated separate occurrence, and in analogy with the notation for four-poles, the submatrices will be denoted by different capitals, as in (2).

Single elements of matrices or submatrices will be denoted by superscripts:

$$\mathbf{v}_1 = \begin{bmatrix} v_1^1 \\ v_1^2 \\ \vdots \\ v_1^n \end{bmatrix}.$$

¹³ S. O. Rice, "Steady state solutions of transmission line equations," *Bell Sys. Tech. Jour.*, vol. 20, p. 131; April, 1941.

¹⁴ *Ibid.*, p. 151.

¹⁵ E. A. Guillemin, "The Mathematics of Circuit Analysis," John Wiley and Sons, New York, N. Y.; 1949.

In order to conserve space, a column matrix will sometimes be written in a row, with special brackets:

$$\mathbf{v} = \{ \mathbf{v}_1, \mathbf{v}_2 \} = \{ v_1^1, v_1^2 \cdots v_1^n, v_2^1, v_2^2 \cdots v_2^n \}.$$

\mathbf{A}' denotes the transpose of \mathbf{A} . The unit matrix, of any order, will be denoted by \mathbf{I} , and its order will either be obvious from the context, or explicitly specified. All other notations, if not self-explanatory, will be defined on their first occurrence.

THE LINEAR MULTI-TERMINAL TRANSDUCER

Consider a network with $2n$ terminals (Fig. 1), of which n terminals are specified as input terminals (conventionally placed on the left) and n output terminals (on the right). Furthermore, let there be a one-one correspondence between the set of input terminals and the set of output terminals, so that a numbering $1, 2, \dots, n$ at the input would unambiguously define the numbering at the output. Let v_1^p denote the voltage of the p -th input terminal, referred to any arbitrary input terminal, and i_1^p the current *into* it; let v_2^q be the voltage of the q -th output terminal, referred to an arbitrary output terminal, and i_2^q the current *out* of it.

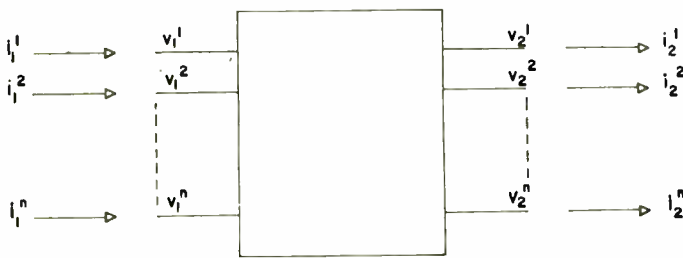

Fig. 1—Multi-terminal transducer.

In a *linear* network, provided there is any relation between $\mathbf{v}_1, \mathbf{v}_2, \mathbf{i}_1,$ and \mathbf{i}_2 , it may be expressed by

$$\begin{pmatrix} \mathbf{v}_1 \\ \mathbf{i}_1 \end{pmatrix} = \mathbf{K} \begin{pmatrix} \mathbf{v}_2 \\ \mathbf{i}_2 \end{pmatrix}. \tag{1}$$

\mathbf{K} is a square matrix of order $2n \times 2n$, whose elements are independent of the \mathbf{v} and \mathbf{i} . Nothing is assumed, *a priori*, about the *transfer matrix* \mathbf{K} , except its existence; it may be singular, or not unique, or exhibit any irregular properties. This would not be surprising, as the voltages are not completely and uniquely defined.

Make the following assumptions about \mathbf{v} and \mathbf{i} :

- (a) The sum of all the input currents is zero; the sum of all the output currents is zero.
- (b) The currents do not depend on the voltages of the various terminals, only on voltage *differences* between pairs of terminals belonging to the same set. Hence, an arbitrary voltage v_1^0 (or v_2^0) may be added to all the input (output) voltages, without changing the currents.

These assumptions will put some restrictions on the elements of \mathbf{K} . Further analysis will be facilitated by partitioning \mathbf{K} into four $n \times n$ submatrices,

$$\mathbf{K} = \begin{pmatrix} \mathbf{A} & \mathbf{B} \\ \mathbf{C} & \mathbf{D} \end{pmatrix}, \tag{2}$$

so that (1) is equivalent to

$$\begin{aligned} \mathbf{v}_1 &= \mathbf{A}\mathbf{v}_2 + \mathbf{B}\mathbf{i}_2 \\ \mathbf{i}_1 &= \mathbf{C}\mathbf{v}_2 + \mathbf{D}\mathbf{i}_2. \end{aligned} \tag{3}$$

The elements of \mathbf{A} and \mathbf{D} are dimensionless numbers, \mathbf{B} is an impedance matrix, and \mathbf{C} is an admittance matrix.

The current into the p -th input terminal is

$$i_1^p = \sum_r C^{pr} v_2^r + \sum_s D^{ps} i_2^s \quad (r, s = 1, 2, \dots, n). \tag{4}$$

(In this section, all summations are over the range 1 to n of the index below the summation sign.)

Let the output terminals be open, so that $i_2^s = 0$ for all s . The sum of all the input currents, according to (4) and assumption (a), will be

$$\sum_p i_1^p = \sum_p \sum_r C^{pr} v_2^r = \sum_r \left(\sum_p C^{pr} \right) v_2^r = 0. \tag{5}$$

If this is to be true for any \mathbf{v}_2 ,

$$\sum_p C^{pr} = 0 \quad \text{for all } r. \tag{6}$$

On the other hand, suppose all the output terminals are shorted together, then all the v_2^r are equal; an appropriate constant may be added to all of them (assumption (b)) to make them all zero. The sum of the input currents is then

$$\sum_p i_1^p = \sum_p \sum_s D^{ps} i_2^s = \sum_s \left(\sum_p D^{ps} \right) i_2^s = 0. \tag{7}$$

This however, does not imply that all the $\sum_p D^{ps} = 0$, because $\sum_s i_2^s = 0$. The only necessary implication is that

$$\sum_p D^{ps} = \text{the same for all } s. \tag{8}$$

Now we take the general case (4) and add an arbitrary voltage v_2^0 to all the v_2^r :

$$\begin{aligned} i_1^p &= \sum_r C^{pr} (v_2^r + v_2^0) + \sum_s D^{ps} i_2^s \\ i_1^p &= \sum_r C^{pr} v_2^r + \left(\sum_r C^{pr} \right) v_2^0 + \sum_s D^{ps} i_2^s. \end{aligned} \tag{9}$$

The i_1^p and i_2^s in (9) are the same as in (4), under assumption (b). Subtracting (4) from (9),

$$\left(\sum_r C^{pr} \right) v_2^0 = 0, \tag{10}$$

and, as v_2^0 is arbitrary,

$$\sum_r C^{pr} = 0 \quad \text{for all } r. \tag{11}$$

The voltage of the q -th input terminal, according to (3), is

$$v_1^q = \sum_r A^{qr} v_2^r + \sum_s B^{qs} i_2^s. \quad (12)$$

Add a voltage v_1^0 to all the input voltages, and v_2^0 to all the output voltages,

$$v_1^q + v_1^0 = \sum_r A^{qr}(v_2^r + v_2^0) + \sum_s B^{qs} i_2^s$$

$$= \sum_r A^{qr} v_2^r + \left(\sum_r A^{qr} \right) v_2^0 + \sum_s B^{qs} i_2^s. \quad (13)$$

Subtracting (12) from (13),

$$v_1^0 = \left(\sum_r A^{qr} \right) v_2^0 \text{ for all } q, \quad (14)$$

hence,

$$\sum_r A^{qr} = \text{the same for all } q. \quad (15)$$

Equations (6), (8), (11), and (15) are the restrictions imposed on \mathbf{K} , due to assumptions (a) and (b) above.

To summarize the results: If no terminal is specified as the voltage reference point, the voltages and currents have to be restricted according to assumptions (a) and (b), and this results in the following:

1. The sum of all the elements in any row of \mathbf{A} is the same.
2. The sum of all the elements in any column of \mathbf{D} is the same.
3. The sum of all the elements in any row or column of \mathbf{C} is zero.

This matrix \mathbf{K} will be referred to as the *indefinite transfer matrix*¹⁶ because the voltage reference terminal is left undefined.

SPECIFYING THE VOLTAGE REFERENCE TERMINAL

Let \mathbf{K} be the indefinite transfer matrix of a m.t.t.' and let the n -th input and output terminals be specified as the reference terminals for the input and output voltages, respectively. We now have $(n-1)$ independent input voltages and $(n-1)$ output voltages, which are the differences between the voltages of the various terminals and those of the respective reference terminals. The "new" voltages constitute $(n-1)$ -rowed columns \bar{v}_1 and \bar{v}_2 , respectively.

In the following discussion assume that $n=4$. The extension of the treatment to any other value of n is obvious.

The voltages \mathbf{v} and $\bar{\mathbf{v}}$ are related by

$$v^r - v^4 = \bar{v}^r \quad (r = 1, 2, 3), \quad (16)$$

but we may add a voltage $-v^4$ to all the components of \mathbf{v} , so that

$$v^r = \bar{v}^r \quad (r = 1, 2, 3)$$

$$v^4 = 0. \quad (17)$$

¹⁶ J. Shekel, "Voltage reference node—its transformations in nodal analysis," *Wireless Eng.*, vol. 31, p. 6; January, 1954. See also J. Shekel, "Matrix representation of transistor circuits," *Proc. I.R.E.*, vol. 40, p. 1493; November, 1952.

The last expression, written in matrix form, is

$$\mathbf{v} = \mathbf{P}\bar{\mathbf{v}}, \text{ where } \mathbf{P} = \begin{pmatrix} 1 & 0 & 0 \\ 0 & 1 & 0 \\ 0 & 0 & 1 \\ 0 & 0 & 0 \end{pmatrix}. \quad (18)$$

The "old" currents \mathbf{i} (4 components) may also be expressed by "new" currents $\bar{\mathbf{i}}$ (3 components),

$$\left. \begin{aligned} i^s &= \bar{i}^s \quad (s = 1, 2, 3) \\ i^4 &= -\bar{i}^1 - \bar{i}^2 - \bar{i}^3 \end{aligned} \right\}, \quad (19)$$

with the last line following from assumption (b). In matrix notation

$$\mathbf{i} = \mathbf{Q}\bar{\mathbf{i}}, \text{ where } \mathbf{Q} = \begin{pmatrix} 1 & 0 & 0 \\ 0 & 1 & 0 \\ 0 & 0 & 1 \\ -1 & -1 & -1 \end{pmatrix}. \quad (20)$$

The problem now is to find a transfer matrix $\bar{\mathbf{K}}$ that relates the input and output quantities defined above.

The column $\{\mathbf{v}, \mathbf{i}\}$ may be transformed by

$$\begin{pmatrix} \mathbf{v} \\ \mathbf{i} \end{pmatrix} = \begin{pmatrix} \mathbf{P} & 0 \\ 0 & \mathbf{Q} \end{pmatrix} \times \begin{pmatrix} \bar{\mathbf{v}} \\ \bar{\mathbf{i}} \end{pmatrix}, \quad (21)$$

which is the same as (18) and (20) written together. Equation (1) then becomes

$$\begin{pmatrix} \mathbf{P} & 0 \\ 0 & \mathbf{Q} \end{pmatrix} \times \begin{pmatrix} \bar{\mathbf{v}}_1 \\ \bar{\mathbf{i}}_1 \end{pmatrix} = \mathbf{K} \times \begin{pmatrix} \mathbf{P} & 0 \\ 0 & \mathbf{Q} \end{pmatrix} \times \begin{pmatrix} \bar{\mathbf{v}}_2 \\ \bar{\mathbf{i}}_2 \end{pmatrix}. \quad (22)$$

Although the matrix on the extreme left of (22) is singular, the equation may be solved for $\{\bar{\mathbf{v}}_1, \bar{\mathbf{i}}_1\}$. From (18) and (20), it is easy to check that

$$\mathbf{P}'\mathbf{Q} = \mathbf{Q}'\mathbf{P} = \mathbf{I}, \quad (23)$$

a 3×3 unit matrix; then

$$\begin{pmatrix} \mathbf{Q}' & 0 \\ 0 & \mathbf{P}' \end{pmatrix} \times \begin{pmatrix} \mathbf{P} & 0 \\ 0 & \mathbf{Q} \end{pmatrix} = \begin{pmatrix} \mathbf{Q}'\mathbf{P} & 0 \\ 0 & \mathbf{P}'\mathbf{Q} \end{pmatrix} = \mathbf{I}, \quad (24)$$

a 6×6 unit matrix. (22) is therefore premultiplied by

$$\begin{pmatrix} \mathbf{Q}' & 0 \\ 0 & \mathbf{P}' \end{pmatrix},$$

yielding

$$\begin{pmatrix} \bar{\mathbf{v}}_1 \\ \bar{\mathbf{i}}_1 \end{pmatrix} = \begin{pmatrix} \mathbf{Q}' & 0 \\ 0 & \mathbf{P}' \end{pmatrix} \times \mathbf{K} \times \begin{pmatrix} \mathbf{P} & 0 \\ 0 & \mathbf{Q} \end{pmatrix} \times \begin{pmatrix} \bar{\mathbf{v}}_2 \\ \bar{\mathbf{i}}_2 \end{pmatrix}. \quad (25)$$

The required transfer matrix is, then,

$$\bar{\mathbf{K}} = \begin{pmatrix} \mathbf{Q}' & 0 \\ 0 & \mathbf{P}' \end{pmatrix} \times \mathbf{K} \times \begin{pmatrix} \mathbf{P} & 0 \\ 0 & \mathbf{Q} \end{pmatrix}. \quad (26)$$

The transformation for the submatrices of \mathbf{K} is

$$\bar{\mathbf{K}} = \begin{pmatrix} \mathbf{Q}' & 0 \\ 0 & \mathbf{P}' \end{pmatrix} \times \begin{pmatrix} \mathbf{A} & \mathbf{B} \\ \mathbf{C} & \mathbf{D} \end{pmatrix} \times \begin{pmatrix} \mathbf{P} & 0 \\ 0 & \mathbf{Q} \end{pmatrix}$$

$$= \begin{vmatrix} Q'AP & Q'BQ \\ P'CP & P'DQ \end{vmatrix}, \tag{27}$$

$$\begin{matrix} \bar{A} = Q'AP & \bar{B} = Q'BQ \\ \bar{C} = P'CP & \bar{D} = P'DQ \end{matrix} \tag{28}$$

When **P** and **Q** are written in full, and the multiplication carried out, the final result, written for a general *n*, is

$$\begin{aligned} A^{rs} &= A^{rs} - A^{ns} \\ \bar{B}^{rs} &= B^{rs} - B^{ns} - B^{rn} + B^{nn} \\ \bar{C}^{rs} &= C^{rs} \\ \bar{D}^{rs} &= D^{rs} - D^{rn} \quad (r, s = 1, 2, \dots, n - 1). \end{aligned} \tag{29}$$

These, then, are the components of the *definite* transfer matrix $\bar{\mathbf{K}}$, as obtained from those of the indefinite matrix, due to the specification of the *n*-th input and output terminals as voltage reference points. The numbering of the terminals, of course, is arbitrary, so that any terminal pair (input and output) may be chosen as "ground," and the transfer matrix transformed by (29).

ADMITTANCE AND IMPEDANCE MATRICES¹⁷

An alternative representation of a four-pole, other than by its transfer matrix, is by its admittance or impedance matrix. We will apply this method to the m.t.t., and define its admittance by the matrix **Y** in

$$\{i_1, -i_2\} = \mathbf{Y}\{v_1, v_2\}, \tag{30}$$

and its impedance by **Z**(=**Y**⁻¹) in

$$\{v_1, v_2\} = \mathbf{Z}\{i_1, -i_2\}, \tag{31}$$

*v*₁, *v*₂, *i*₁ and *i*₂ having the same meaning as in (1).

It should be noted that in this representation all the currents are treated as entering the terminals, hence the negative sign prefixing *i*₂.

To derive **Y** from **K**, (1) is written as two equations

$$\begin{aligned} v_1 &= Av_2 + Bi_2 \\ i_1 &= Cv_2 + Di_2 \\ Bi_2 &= v_1 - Av_2 \\ i_2 &= B^{-1}v_1 - B^{-1}Av_2 \\ i_1 &= Cv_2 + D(B^{-1}v_1 - B^{-1}Av_2) \\ &= Cv_2 + DB^{-1}v_1 - DB^{-1}Av_2 \\ &= DB^{-1}v_1 + (C - DB^{-1}A)v_2. \end{aligned} \tag{32}$$

Comparing (32) and (33) with (30),

$$\mathbf{Y} = \begin{vmatrix} DB^{-1} & C - DB^{-1}A \\ -B^{-1} & B^{-1}A \end{vmatrix}. \tag{34}$$

By a similar derivation,

$$\mathbf{Z} = \begin{vmatrix} AC^{-1} & AC^{-1}D - B \\ C^{-1} & C^{-1}D \end{vmatrix}. \tag{35}$$

The inverse of **C** appears in all the submatrices of **Z**. In the indefinite form of **K**, **C** is singular (see (6) and (11)); but when **K** is expressed in definite form, one row and one column of **C** are removed, so that it is no longer singular. It is therefore possible to use the impedance representation only in the definite form. On the other hand, it is the inverse of **B** that appears in **Y**, and as there are no restrictions on **B**, the admittance representation may be used in the indefinite form as well as in the definite one.

The inverse transformation, from **Y** or **Z** to **K**, is similarly derived:

$$\begin{aligned} i_1 &= Y_{11}v_1 + Y_{12}v_2 \\ -i_2 &= Y_{21}v_1 + Y_{22}v_2 \\ Y_{21}v_1 &= -Y_{22}v_2 - i_2 \\ v_1 &= -Y_{21}^{-1}Y_{22}v_2 - Y_{21}^{-1}i_2, \end{aligned} \tag{36}$$

$$\begin{aligned} i_1 &= Y_{11}(-Y_{21}^{-1}Y_{22}v_2 - Y_{21}^{-1}i_2) + Y_{12}v_2 \\ i_1 &= (Y_{12} - Y_{11}Y_{21}^{-1}Y_{22})v_2 - Y_{11}Y_{21}^{-1}i_2. \end{aligned} \tag{37}$$

Comparing (36) and (37) with (1),

$$\mathbf{K} = \begin{vmatrix} -Y_{21}^{-1}Y_{22} & -Y_{21}^{-1} \\ Y_{12} - Y_{11}Y_{21}^{-1}Y_{22} & -Y_{11}Y_{21}^{-1} \end{vmatrix}. \tag{38}$$

A similar derivation, starting from **Z**, results in

$$\mathbf{K} = \begin{vmatrix} Z_{11}Z_{21}^{-1} & Z_{11}Z_{21}^{-1}Z_{22} - Z_{12} \\ Z_{21}^{-1} & Z_{21}^{-1}Z_{22} \end{vmatrix}. \tag{39}$$

Transformations (34), (35), (38), and (39) are well known in four-pole theory; only there the submatrices are scalars, so that the expressions are written somewhat differently. For example, in (39),

$$B = Z_{11}Z_{21}^{-1}Z_{22} - Z_{12},$$

whereas, in a four-pole, it is usually written as

$$B = \frac{Z_{11}Z_{22} - Z_{12}Z_{21}}{Z_{21}} = \frac{|Z|}{Z_{21}}.$$

RECIPROCITY

Nothing has been assumed, so far, about reciprocity relations in the network. All that was said in the preceding sections, and will be said in the sections following, applies to networks which may contain vacuum tubes, transistors or gyrators, in addition to bilateral elements, with the only restriction that all elements operate in their linear ranges. In this section we will discuss a special type of the general linear network, viz. the class of networks that exhibit the reciprocity relation. It is to be expected that this restriction on the generality of the network will be reflected in its transfer matrix.

The reciprocity relation is expressed by the symmetry of the **Y** and **Z** matrices. From the symmetry of **Y**,

$$Y_{11} = Y_{11}' \tag{40}$$

$$Y_{22} = Y_{22}' \tag{41}$$

$$Y_{12} = Y_{21}'. \tag{42}$$

¹⁷ The results of this section and the following one are brought by Rice, in an appendix to his paper, "Steady state solutions of transmission line equations," *ibid.*

From (34) and (40),

$$\begin{aligned} DB^{-1} &= (DB^{-1})' = (B^{-1})'D' \\ B'DB^{-1} &= D' \\ B'D &= D'B, \end{aligned} \tag{43}$$

while (34) and (41) yield

$$\begin{aligned} B^{-1}A &= (B^{-1}A)' = A'(B^{-1})' \\ AB' &= BA'. \end{aligned} \tag{44}$$

(42) is equivalent to

$$\begin{aligned} -(B')^{-1} &= C - DB^{-1}A \\ C &= DB^{-1}A - (B')^{-1} \\ &= (B')^{-1}D'A - (B')^{-1} \\ &= (B')^{-1}(D'A - I) \\ B'C &= D'A - I \\ D'A - B'C &= I, \end{aligned} \tag{45}$$

or, proceeding differently,

$$\begin{aligned} C &= DB^{-1}A - (B')^{-1} \\ &= DA'(B')^{-1} - (B')^{-1} \\ &= (DA' - I)(B')^{-1} \\ CB' &= DA' - I \\ DA' - CB' &= I. \end{aligned} \tag{46}$$

A similar derivation, starting with the symmetry of Z , gives four analogous results:

$$C'A = A'C \tag{47}$$

$$DC' = CD' \tag{48}$$

$$A'D - C'B = I \tag{49}$$

$$AD' - BC' = I. \tag{50}$$

The eight restrictions, (43) to (50), are equivalent to

$$\begin{vmatrix} A & B \\ C & D \end{vmatrix}^{-1} = \begin{vmatrix} D' & -B' \\ -C' & A' \end{vmatrix}, \tag{51}$$

as may easily be confirmed by direct multiplication of both matrices.

In four-poles, where A, B, C and D are scalars, (43), (44), (47) and (48) are no restrictions, and the other four results merge into one, which is the only consequence of the reciprocity relation:

$$|K| = AD - BC = 1.$$

SYMMETRY

A multi-terminal transducer is symmetrical if its transfer matrix is invariant to the interchange of roles between input and output terminals.

The interchange implies reversal of signs of both i_1 and i_2 , to conform with the accepted definitions, so that after the interchange

$$\begin{vmatrix} v_2 \\ -i_2 \end{vmatrix} = \begin{vmatrix} A & B \\ C & D \end{vmatrix} \times \begin{vmatrix} v_1 \\ -i_1 \end{vmatrix}, \tag{52}$$

or,

$$\begin{vmatrix} v_2 \\ i_2 \end{vmatrix} = \begin{vmatrix} A & -B \\ -C & D \end{vmatrix} \times \begin{vmatrix} v_1 \\ i_1 \end{vmatrix}. \tag{53}$$

Comparing (1), (2) and (53),

$$\begin{vmatrix} A & B \\ C & D \end{vmatrix}^{-1} = \begin{vmatrix} A & -B \\ -C & D \end{vmatrix}. \tag{54}$$

By direct multiplication, (54) may be expressed by four relations,

$$A^2 - BC = I \tag{55}$$

$$D^2 - CB = I \tag{56}$$

$$AB = BD \tag{57}$$

$$DC = CA. \tag{58}$$

If the transducer exhibits both symmetry and reciprocity, (54) and (51) are to be satisfied simultaneously; then

$$A = D'; \quad B = B'; \quad C = C'. \tag{59}$$

In four-poles, (57) and (58) are equivalent to $A = D$; while this and (55) or (56) show that

$$|K| = AD - BC = A^2 - BC = D^2 - BC = 1,$$

and (59) adds nothing new.

Indeed, in a four-pole, symmetry ($Y_{11} = Y_{22}, Y_{12} = Y_{21}$) implies reciprocity ($Y_{12} = Y_{21}$). On the other hand, a m.t.t. may be symmetrical ($Y_{12} = Y_{21}$) without exhibiting reciprocity ($Y_{12} \neq Y_{21}'$); see, for example, the network in Fig. 2, which is symmetrical, but does not obey the reciprocity relation, due to the presence of the vacuum tube.

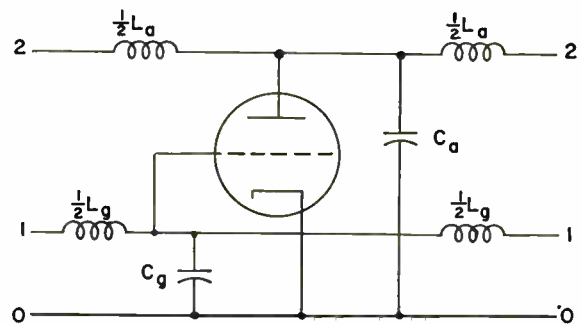

Fig. 2—One section of a distributed amplifier.

ADMITTANCE AND IMPEDANCE TRANSFORMATIONS

An n -terminal transducer may be terminated by an n -terminal network. The termination is represented by a square matrix Y_2 or Z_2 ,

$$i_2 = Y_2 v_2, \tag{60}$$

$$v_2 = Z_2 i_2, \tag{61}$$

and the admittance representation may be definite or indefinite.¹⁶ Y_2 is the admittance matrix obtained from a nodal analysis of the network, Z_2 is the inverse of Y_2 , when the latter is expressed in its definite form. (Neither

Y_2 nor Z_2 is connected with the mesh analysis of the terminating network.)

The terminated transducer appears at its input terminals as an n -terminal network of admittance Y_1 or impedance Z_1 . The transducer thus transforms Y_2 into Y_1 or Z_2 into Z_1 .

The transfer equation (1) may be written as

$$\begin{aligned} \mathbf{v}_1 &= \mathbf{A}\mathbf{v}_2 + \mathbf{B}(\mathbf{Y}_2\mathbf{v}_2) \\ (\mathbf{Y}_1\mathbf{v}_1) &= \mathbf{C}\mathbf{v}_2 + \mathbf{D}(\mathbf{Y}_2\mathbf{v}_2), \end{aligned}$$

whence

$$\mathbf{Y}_1(\mathbf{A} + \mathbf{B}\mathbf{Y}_2)\mathbf{v}_2 = (\mathbf{C} + \mathbf{D}\mathbf{Y}_2)\mathbf{v}_2;$$

this is true for any \mathbf{v}_2 , so that

$$\mathbf{Y}_1 = (\mathbf{C} + \mathbf{D}\mathbf{Y}_2)(\mathbf{A} + \mathbf{B}\mathbf{Y}_2)^{-1}. \quad (62)$$

The impedance transformation is obtained if we write (1) as

$$\begin{aligned} (\mathbf{Z}_1\mathbf{i}_1) &= \mathbf{A}(\mathbf{Z}_2\mathbf{i}_2) + \mathbf{B}\mathbf{i}_2 \\ \mathbf{i}_1 &= \mathbf{C}(\mathbf{Z}_2\mathbf{i}_2) + \mathbf{D}\mathbf{i}_2, \end{aligned}$$

then

$$\begin{aligned} \mathbf{Z}_1(\mathbf{C}\mathbf{Z}_2 + \mathbf{D})\mathbf{i}_2 &= (\mathbf{A}\mathbf{Z}_2 + \mathbf{B})\mathbf{i}_2 \\ \mathbf{Z}_1 &= (\mathbf{A}\mathbf{Z}_2 + \mathbf{B})(\mathbf{C}\mathbf{Z}_2 + \mathbf{D})^{-1}. \quad (63) \end{aligned}$$

Transformations (62) and (63) are well known in four-pole theory, only there they are usually written as quotients of scalar expressions.

DERIVATION OF THE TRANSFER MATRIX OF A GIVEN TRANSDUCER

Cascading

Two m.t.t.'s may be connected *in cascade*, so that the output terminals of one are the input terminals of the other. Let \mathbf{K}_1 and \mathbf{K}_2 be the transfer matrices of the transducers, respectively. The transfer from the first set of terminals to the second one is

$$\{\mathbf{v}_1, \mathbf{i}_1\} = \mathbf{K}_1\{\mathbf{v}_2, \mathbf{i}_2\}$$

and from the second to the third

$$\{\mathbf{v}_2, \mathbf{i}_2\} = \mathbf{K}_2\{\mathbf{v}_3, \mathbf{i}_3\}.$$

The total transfer from the first to the third is then

$$\{\mathbf{v}_1, \mathbf{i}_1\} = \mathbf{K}_1\mathbf{K}_2\{\mathbf{v}_3, \mathbf{i}_3\},$$

so that the two cascaded transducers are equivalent to a single m.t.t. whose transfer matrix is

$$\mathbf{K} = \mathbf{K}_1\mathbf{K}_2. \quad (64)$$

Conversely, a complicated m.t.t. may sometimes be split into a cascade of simpler sections, and its transfer matrix derived as a product of simple transfer matrices.

We will now proceed to derive the transfer matrices of some simple sections, which may be used by themselves or as building blocks for more complicated m.t.t.'s.

Series section

In the m.t.t. shown in Fig. 3 it is evident that

$$\mathbf{i}_1 = \mathbf{i}_2, \quad (65)$$

but

$$\mathbf{v}_1 = \mathbf{v}_2 + \mathbf{Z}\mathbf{i}_2. \quad (66)$$

\mathbf{Z} is a square matrix, where Z^{pp} is the impedance of the element between the p - p terminals, and Z^{pq} is the

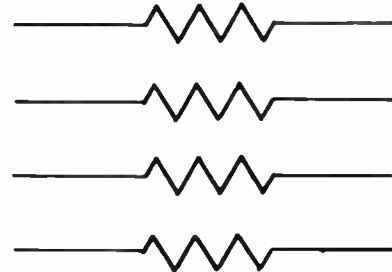

Fig. 3—Series section.

mutual impedance between the elements in the p - q and q - q branches. Comparing (65) and (66) with (1), we see that for the series section

$$\mathbf{K} = \begin{vmatrix} \mathbf{I} & \mathbf{Z} \\ 0 & \mathbf{I} \end{vmatrix}. \quad (67)$$

This \mathbf{K} is in its indefinite form.

Shunt section

The m.t.t. in Fig. 4 has

$$\mathbf{v}_1 = \mathbf{v}_2, \quad (68)$$

and

$$\mathbf{i}_1 = \mathbf{i}_2 + \mathbf{Y}\mathbf{v}_2. \quad (69)$$

Here \mathbf{Y} is the indefinite admittance matrix of the shunting network. If this network comprises 2-terminal elements only, Y^{pp} is the sum of the admittances of the

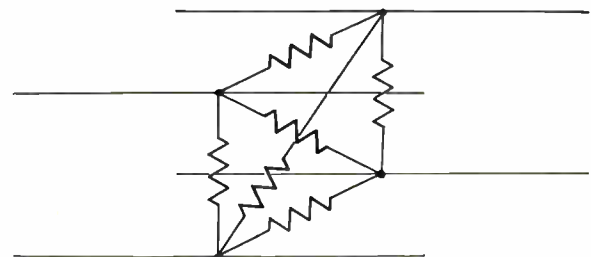

Fig. 4—Shunt section.

elements connected to the p terminals, and Y^{pq} is the negative of the admittance of the element in the branch between the p and q terminals.

(68) and (69) together give

$$\mathbf{K} = \begin{vmatrix} \mathbf{I} & 0 \\ \mathbf{Y} & \mathbf{I} \end{vmatrix} \quad (70)$$

as the indefinite transfer matrix of the shunt section.

"Twist" section

Fig. 5 shows a m.t.t. whose only effect is to introduce a "twist" between the input and output terminals. The components of v_2 are merely a permutation of those of v_1 , and i_2 is similarly derived from i_1 by the same permutation.

$$\begin{aligned} v_1 &= T v_2 \\ i_1 &= T i_2 \end{aligned} \tag{71}$$

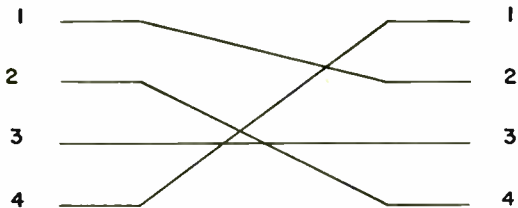

Fig. 5—Twist section.

T is a square matrix, constructed as follows: for each connection between the p -th input terminal and q -th output terminal, $T_{pq} = 1$; all other elements of T are zero. For the network in Fig. 5,

$$T = \begin{vmatrix} 0 & 1 & 0 & 0 \\ 0 & 0 & 0 & 1 \\ 0 & 0 & 1 & 0 \\ 1 & 0 & 0 & 0 \end{vmatrix}$$

(71) indicates that the indefinite transfer matrix of a twist section is

$$K = \begin{vmatrix} T & 0 \\ 0 & T \end{vmatrix} \tag{72}$$

More complicated sections

Some sections, like lattices or bridged sections, cannot be treated as cascades of simpler sections. Fig. 6 may serve as an example, which, but for the element b , could be treated as a cascade of a series section and a twist section. A m.t.t. like this may easily be analyzed, by first writing its admittance matrix, then passing to the transfer matrix via (38).

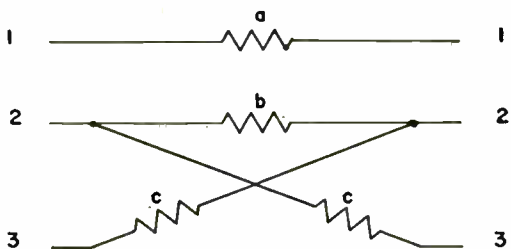

Fig. 6—Section to be analyzed by the admittance matrix.

In the example shown in Fig. 6, a , b and c denote admittance values. The indefinite admittance matrix of the network is

$$Y = \begin{vmatrix} a & 0 & 0 & -a & 0 & 0 \\ 0 & b+c & 0 & 0 & -b & -c \\ 0 & 0 & c & 0 & -c & 0 \\ \dots & \dots & \dots & \dots & \dots & \dots \\ -a & 0 & 0 & a & 0 & 0 \\ 0 & -b & -c & 0 & b+c & 0 \\ 0 & -c & 0 & 0 & 0 & c \end{vmatrix}$$

From (38) we get the four submatrices of K :

$$|Y_{21}| = \begin{vmatrix} -a & 0 & 0 \\ 0 & -b & -c \\ 0 & -c & 0 \end{vmatrix} = ac^2$$

$$B = -Y_{21}^{-1} = -\frac{1}{ac^2} \times \begin{vmatrix} -c^2 & 0 & 0 \\ 0 & 0 & -ac \\ 0 & -ac & ab \end{vmatrix}$$

$$B = \begin{vmatrix} \frac{1}{a} & 0 & 0 \\ 0 & 0 & \frac{1}{c} \\ 0 & \frac{1}{c} & -\frac{b}{c^2} \end{vmatrix}$$

$$A = -Y_{21}^{-1} Y_{22} = B Y_{22}$$

$$= \begin{vmatrix} \frac{1}{a} & 0 & 0 \\ 0 & 0 & \frac{1}{c} \\ 0 & \frac{1}{c} & -\frac{b}{c^2} \end{vmatrix} \times \begin{vmatrix} a & 0 & 0 \\ 0 & b+c & 0 \\ 0 & 0 & c \end{vmatrix}$$

$$A = \begin{vmatrix} 1 & 0 & 0 \\ 0 & 0 & 1 \\ 0 & 1 + \frac{b}{c} & -\frac{b}{c} \end{vmatrix}$$

$$D = -Y_{11} Y_{21}^{-1} = Y_{11} B$$

$$= \begin{vmatrix} a & 0 & 0 \\ 0 & b+c & 0 \\ 0 & 0 & c \end{vmatrix} \times \begin{vmatrix} \frac{1}{a} & 0 & 0 \\ 0 & 0 & \frac{1}{c} \\ 0 & \frac{1}{c} & -\frac{b}{c^2} \end{vmatrix}$$

$$D = \begin{vmatrix} 1 & 0 & 0 \\ 0 & 0 & 1 + \frac{b}{c} \\ 0 & 1 & -\frac{b}{c} \end{vmatrix}$$

$$C = Y_{12} - Y_{11} Y_{21}^{-1} Y_{22} = Y_{12} + D Y_{22}$$

$$\begin{aligned}
 &= \begin{vmatrix} -a & 0 & 0 \\ 0 & -b & -c \\ 0 & -c & 0 \end{vmatrix} + \begin{vmatrix} 1 & 0 & 0 \\ 0 & 0 & 1 + \frac{b}{c} \\ 0 & 1 & -\frac{b}{c} \end{vmatrix} \\
 &\times \begin{vmatrix} a & 0 & 0 \\ 0 & b + c & 0 \\ 0 & 0 & c \end{vmatrix} \\
 &= \begin{vmatrix} -a & 0 & 0 \\ 0 & -b & -c \\ 0 & -c & 0 \end{vmatrix} + \begin{vmatrix} a & 0 & 0 \\ 0 & 0 & b + c \\ 0 & b + c & -b \end{vmatrix} \\
 \mathbf{C} &= \begin{vmatrix} 0 & 0 & 0 \\ 0 & -b & b \\ 0 & b & -b \end{vmatrix}.
 \end{aligned}$$

$$\mathbf{K} = \begin{vmatrix} 1 - \frac{1}{2}\omega^2 L_a C_a & 0 & j\omega L_a (1 - \frac{1}{4}\omega^2 L_a C_a) & 0 \\ \frac{1}{2}j\omega L_a G_m & 1 - \frac{1}{2}\omega^2 L_a C_a + \frac{1}{2}j\omega L_a G_a & -\frac{1}{4}\omega^2 L_a L_a G_m & j\omega L_a (1 - \frac{1}{4}\omega^2 L_a C_a) - \frac{1}{4}\omega^2 L_a^2 G_a \\ j\omega C_a & 0 & 1 - \frac{1}{2}\omega^2 L_a C_a & 0 \\ G_m & G_a + j\omega C_a & \frac{1}{2}j\omega L_a G_m & 1 - \frac{1}{2}\omega^2 L_a C_a + \frac{1}{2}j\omega L_a G_a \end{vmatrix}.$$

This example illustrates some of the general results which have been derived:

1. The transfer matrix is indefinite. The sum of each row and column of **C** is zero, the sum of each column of **D** is 1, and the sum of each row of **A** is 1.
2. The network is symmetrical, and obeys the reciprocity relation. **B** and **C** are symmetrical matrices, and **A** is the transpose of **D**, as in (59). All the other relations, viz. (43) to (50) for reciprocity, and (55) to (58) for symmetry, may also be checked by a simple computation.

DISTRIBUTED AMPLIFIER

As a concluding illustrative example, we will derive the transfer matrix for the section of a distributed amplifier shown in Fig. 2. As there is an obvious ground line running through the section, the definite representation will be used.

The section may be treated as a cascade of three sections, of the series-shunt-series type. (This is a generalization of the T-section in four-pole theory.) The complete transfer matrix, in the general case, is

$$\begin{aligned}
 \mathbf{K} &= \mathbf{K}_1 \mathbf{K}_2 \mathbf{K}_3 = \begin{vmatrix} \mathbf{I} & \mathbf{Z}_1 \\ 0 & \mathbf{I} \end{vmatrix} \times \begin{vmatrix} \mathbf{I} & 0 \\ \mathbf{Y}_2 & \mathbf{I} \end{vmatrix} \times \begin{vmatrix} \mathbf{I} & \mathbf{Z}_3 \\ 0 & \mathbf{I} \end{vmatrix} \\
 &= \begin{vmatrix} \mathbf{I} + \mathbf{Z}_1 \mathbf{Z}_2 & \mathbf{Z}_1 + \mathbf{Z}_1 \mathbf{Y}_2 \mathbf{Z}_3 + \mathbf{Z}_3 \\ \mathbf{Y}_2 & \mathbf{Y}_2 \mathbf{Z}_3 + \mathbf{I} \end{vmatrix}. \quad (73)
 \end{aligned}$$

In the distributed amplifier, the series sections are composed of the inductances

$$\mathbf{Z}_1 = \mathbf{Z}_3 = \begin{vmatrix} j\omega L_a & 0 \\ 0 & j\omega L_a \end{vmatrix}.$$

The shunt section contains the capacitors and the vacuum tube. We shall denote the mutual conductance and the internal conductance of the tube by G_m and G_a , respectively. The electrode-to-cathode capacitances may be assimilated in C_a and C_a .

$$\begin{aligned}
 \mathbf{Y}_2 &= \begin{vmatrix} 0 & 0 \\ G_m & G_a \end{vmatrix} + \begin{vmatrix} j\omega C_a & 0 \\ 0 & j\omega C_a \end{vmatrix} \\
 &= \begin{vmatrix} j\omega C_a & 0 \\ G_m & G_a + j\omega C_a \end{vmatrix}.
 \end{aligned}$$

Substituting these values in (73) we get the complete transfer matrix

This network is symmetrical, but does not obey reciprocity relation, due to presence of the vacuum tube.

CONCLUSION

The multi-terminal transducer is a type of network that includes the four-pole as a special case. All the results derived for the general m.t.t. apply to four-poles, although some of them appear trivial when applied to this special case. In four-poles, the various submatrices are scalars, and then they obey the commutative law in multiplication; scalars are also equal to their own transpose, and these two properties deprive relations like (47), (57), or (59) of any special meaning.

In our treatment, we did or did not specify the voltage reference points, as was more convenient in the case at hand. The use of the indefinite transfer matrix thus gives more freedom in representation or computation. This method is also applicable to four-poles, where it enables to distinguish between "T"-sections (with the series impedance in one lead only) and "H"-sections (with the series impedance distributed, equally or unequally, between both leads), or similar cases.

This paper treated linear m.t.t.'s in general, reciprocal or nonreciprocal, active or passive. The special properties of networks obeying the reciprocity relation were discussed. Energy considerations will be the subject matter of a forthcoming paper.

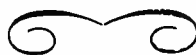

Prolonged Space-Wave Fadeouts at 1,046 MC Observed in Cheyenne Mountain Propagation Program*

BRADFORD R. BEAN†

Summary—During the first year of continuous operation of the Cheyenne Mountain propagation program, recordings of 1,046-mc fields at receiving locations within the radio horizon have exhibited "fadeouts" or prolonged periods of attenuation often in excess of 20 db below the monthly median level and lasting from a minute up to several hours. The occurrence of these fadeouts has been found to coincide with widespread super-refraction as evidenced by enhanced signals beyond the radio horizon and ground modification of the refractive index profile.

ceiving sites used in this study have standard dipole antennas 43 feet above the surrounding plains and are located as follows: (a) well within the radio horizon at Kendrick, Colorado (49.3 miles, $\theta = -0.221$ degrees), (b) near the radio horizon at Karval, Colorado (70.2 miles, $\theta = -0.130$ degrees), and (c) beyond the radio horizon at Haswell, Colorado (96.6 miles, $\theta = 0.102$ de-

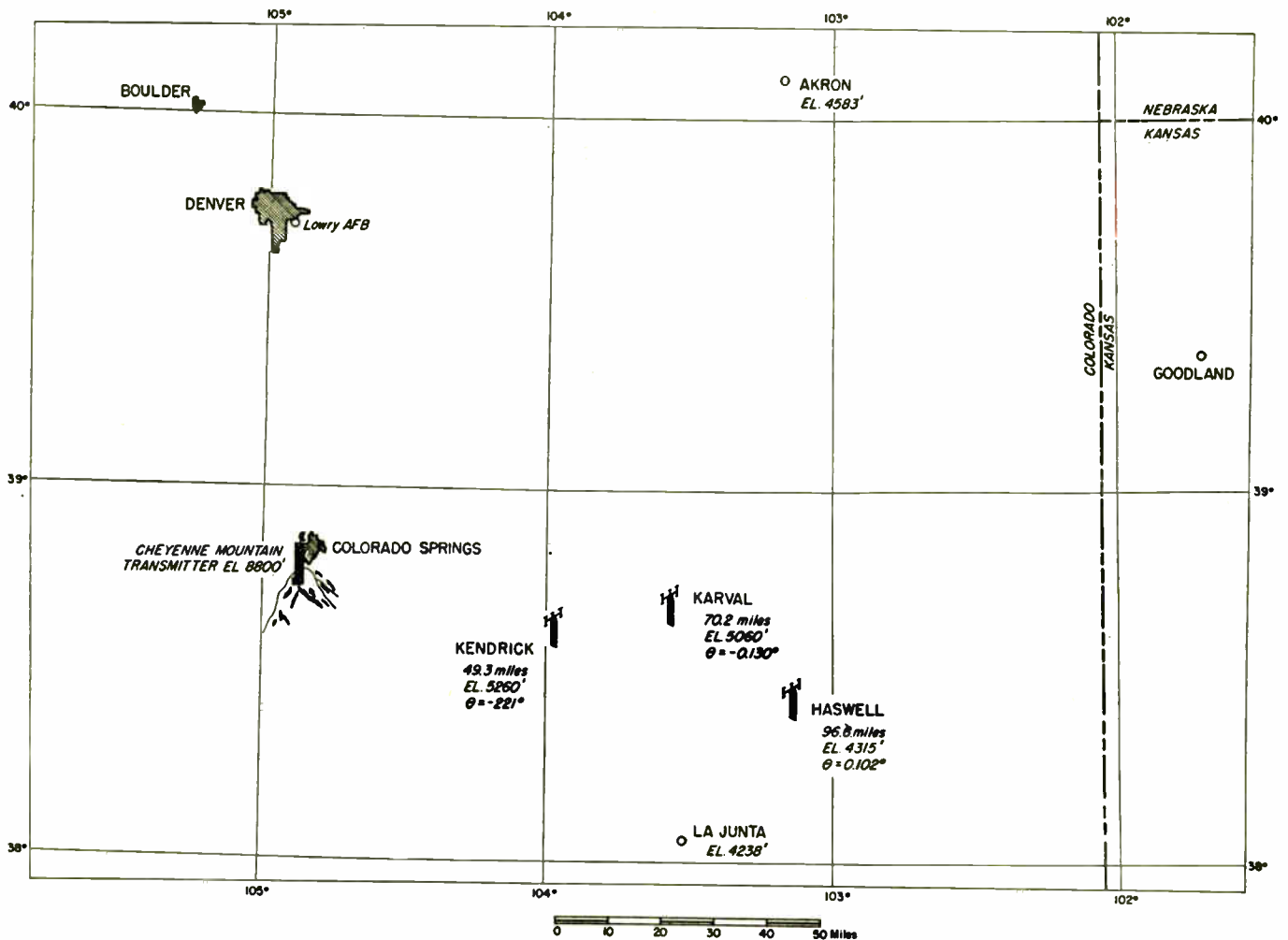

Fig. 1—Transmission paths of the Cheyenne Mountain propagation program.

THE TRANSMISSION PATHS involved in the 1,046-mc Cheyenne Mountain propagation program are shown pictorially in Fig. 1. The transmitter is located on the sheer face of Cheyenne Mountain, approximately 2,800 feet above the surrounding plains, and simulates an air-borne transmitter. The re-

ceiving sites used in this study have standard dipole antennas 43 feet above the surrounding plains and are located as follows: (a) well within the radio horizon at Kendrick, Colorado (49.3 miles, $\theta = -0.221$ degrees). The angle θ is the angle between the lines from the transmitting and receiving antennas to their respective radio horizons, in the great-circle plane containing the antennas for the radio standard atmosphere. This angle θ provides, in a single parameter, an indication of path length, terrain profile, and antenna heights.

Fig. 2 presents simultaneous recordings of the 100-, 192.8-, and 1,046-mc fields at Kendrick and Karval during fadeouts on the morning of September 4, 1952, and

* Decimal classification: R113.1. Original manuscript received by the IRE, September 19, 1953.

† National Bureau of Standards, Boulder, Colo.

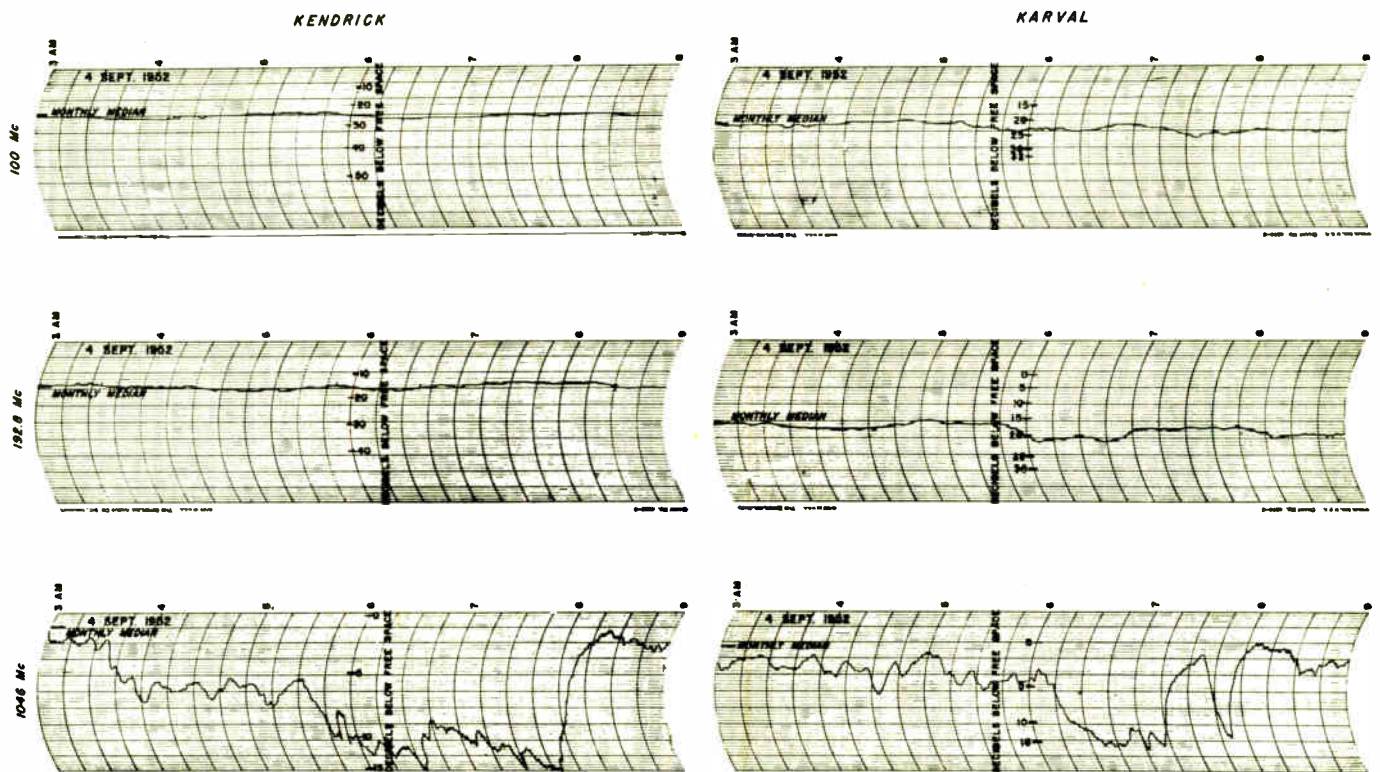

Fig. 2—Recorded 100-, 192.8-, and 1,046-mc fields for the morning of September 4, 1952, at Kendrick and Karval, Colo.

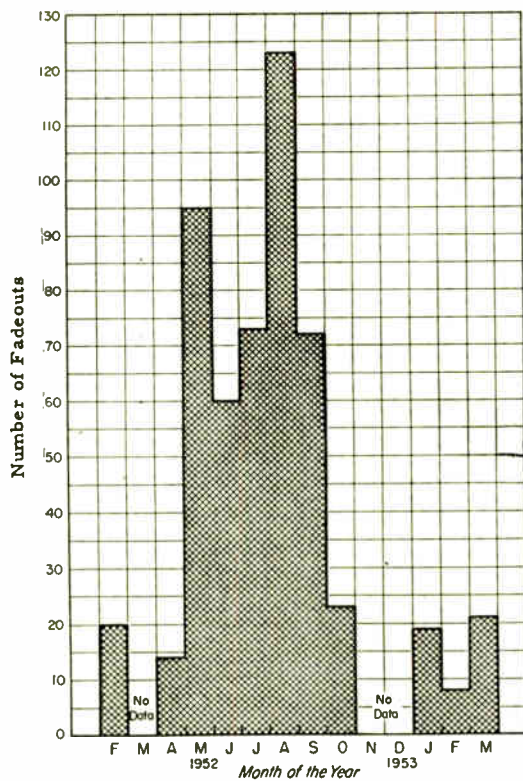

Fig. 3—Annual distribution of normalized occurrences of prolonged space-wave fadeouts observed at 1,046 mc at Karval, Colo.

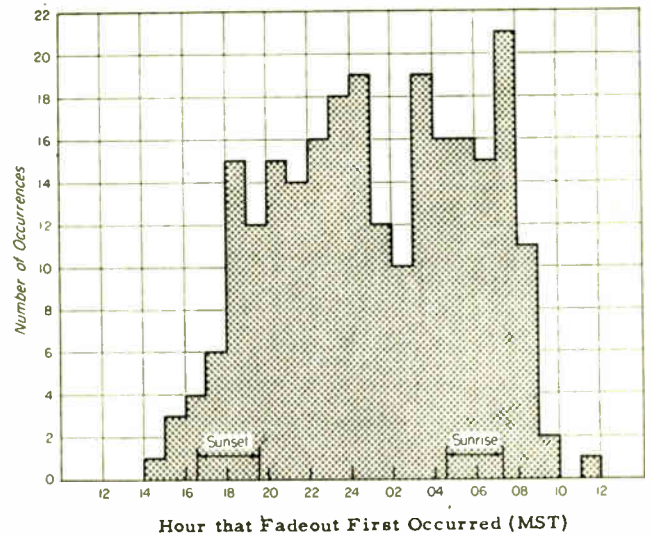

Fig. 4—Diurnal distribution of the 246 prolonged space-wave fadeouts observed at 1,046 mc at Karval, Colo., from February, 1952, to January, 1953.

illustrates the significant fact that these prolonged space-wave fadeouts are of importance only at the higher frequencies. For the purpose of this study, a pro-

longed space-wave fadeout is said to occur whenever the field at Karval on 1,046 mc drops 5 db or more below the monthly median level for one minute or more. The 5-db level was chosen to make the phenomenon operationally significant while the minimum of one minute rules out the rapid phase interference types of fading such as those due to passing aircraft. The normalized monthly frequency of fadeouts is shown in Fig. 3, and the diurnal distributions of the time of onset of these fadeouts is shown in Fig. 4. The data of Fig. 3 have been normal-

ized to allow for periods when the transmitter was off the air. The normalized occurrence of fadeouts was arrived at by the following relationship:

$$F_N = F_0 H_M / H_0$$

where

- F_N = normalized number of fadeouts,
- F_0 = number of fadeouts observed during the month,
- H_0 = number of hours of data during the month,
- H_M = maximum possible hours of data during the month.

H_M/H_0 had a maximum value of 5.71 in October and a minimum of 1.35 in September. Figs. 3 and 4 show a tendency for maximum occurrence during the summer months and during the nighttime hours. The fadeouts have minimum occurrence in the early afternoon, maximum occurrences a few hours after sunset and sunrise, and a secondary minimum in the early morning hours. Fig. 5 shows the percentage of total recording time that the fields were at least 5, 7, 10, and 15 db below the monthly median. May has the maximum occurrence of 5-db fadeouts with 10.5 per cent of the time, while the occurrence for any summer month is in excess of 4.9 per cent of the time; however, since the lowest occurrence, October, is 2.8 per cent, all months have occurrences which are significant for systems designed to operate out to the radio horizon.

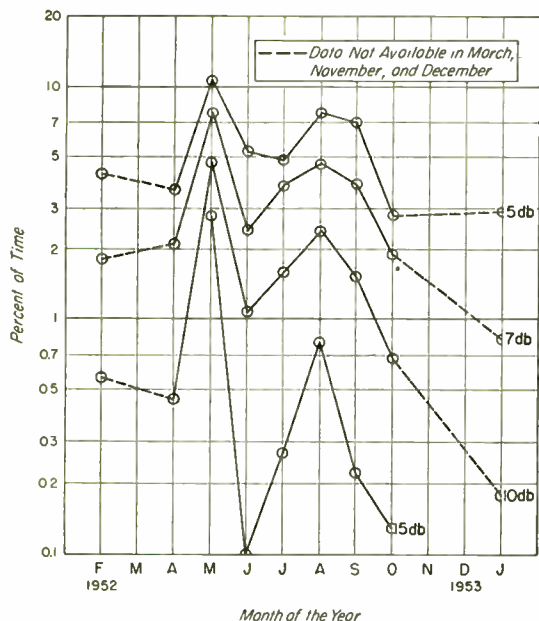

Fig. 5—Percentage of total time for each month that the 1,046-mc field at Karval, Colo., is at least 5, 7, 10, and 15 db below the monthly median field due to prolonged space-wave fadeouts.

Fig. 6 shows cumulative distributions of the durations of individual fadeouts in excess of 5, 10, and 15 db. The operational significance of the fadeouts is again emphasized by noting that 90 per cent of the fadeouts of at least 5 db are at least 6 minutes long, while 50 per cent are of at least 24 minutes duration.

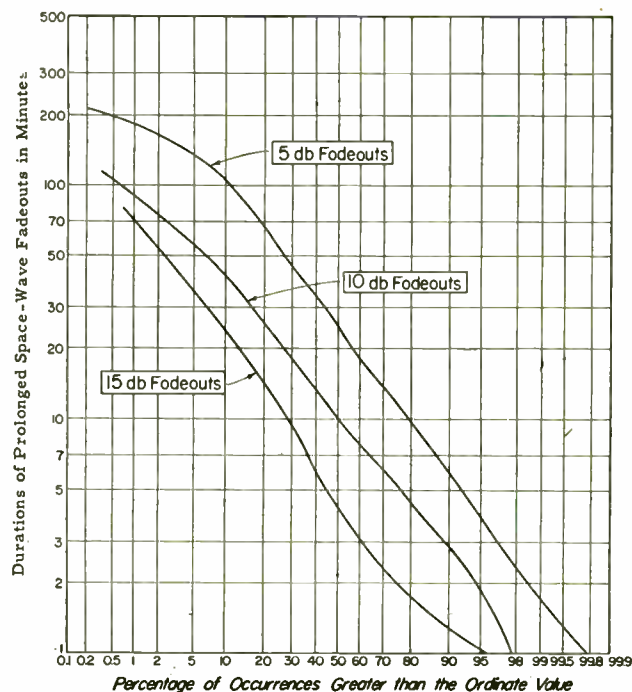

Fig. 6—Cumulative distributions of the durations of prolonged space-wave fadeouts at Karval, Colo.

The dependence of these fadeouts on meteorological conditions was presented during field trials of the NBS mobile low-level sounding system¹ at Haswell, Colorado on the night of June 21–22, 1952. The observed refractivity, N , profiles are shown in Fig. 7, page 851, and show nature of the diurnal variation of the refractivity profile. There was a linear afternoon gradient of $-0.0125 N$ units/meter between the surface and 200 meters (compared with $-0.0392 N$ units/meter in a standard atmosphere). The surface gradient increased as the night went on, the 2320 and 0250 profiles having ducting gradients, i.e., a gradient equal to or greater than $-0.157 N$ units/meter. After sunrise the steep surface gradients were modified by convection to produce profiles similar to those at 0554 or 0945. The 2320 and 0250 profiles are interesting in that they have ducting gradients to heights of 91 and 102 meters, respectively, while the ground-based layers display positive refractivity gradients. Fig. 7 contains reference gradients for both the radio standard atmosphere and ducting, along with their respective equivalent-earth-radius factor, k .

The recorded 1,046-mc fields at Kendrick, Karval, and Haswell during night of June 21–22, 1952, are in Fig. 8, page 852. Starting at 10 p.m., June 21, fadeouts of 5 to 15 db were observed at Kendrick and Karval, while the field beyond the radio horizon at Haswell showed a spectacular rise at 11:30 p.m. An examination of the 100- and 192.8-mc recording charts for Haswell revealed a gradual increase of field, going off scale at midnight, giving evidence of an atmospheric duct. A further con-

¹ P. D. Lowell, W. Hakkarinen, and D. L. Randall, "National Bureau of Standards mobile low-level sounding system," *Jour. Res. Nat. Bur. Stand.*, vol. 50, no. 1; 1953.

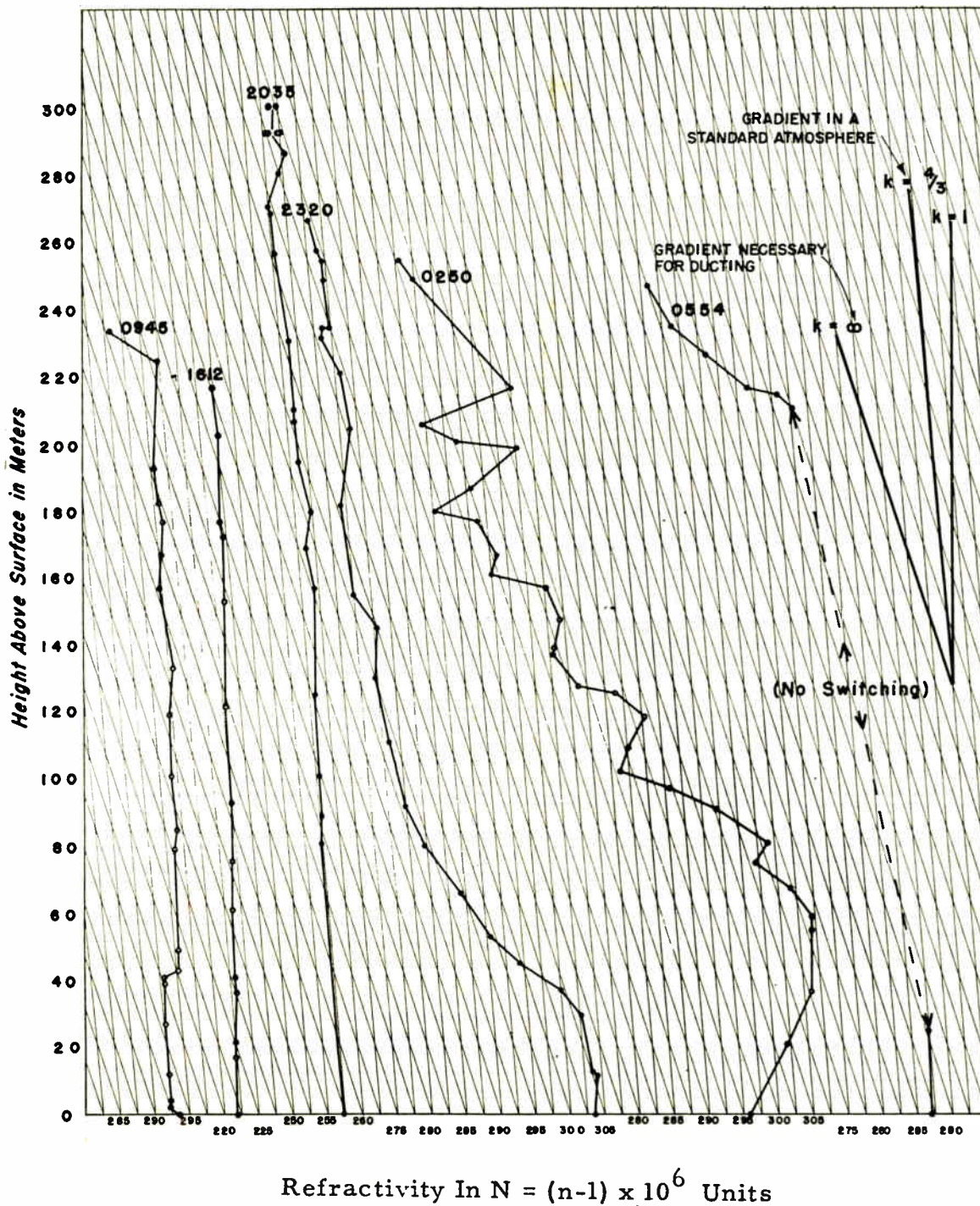

Fig. 7—Vertical distributions of refractivity at Haswell, Colo., for June 21-22, 1952.

dition to be satisfied in ducting theory² is that the ducting refractivity gradient extends over a sufficient height, which for 1,046 mc is about 50 meters. This latter condition is verified by the meteorological measurements described above.

Consideration of the above data sheds some light upon the possible mechanism producing the fadeouts. The most obvious feature is the presence of a duct at

² D. E. Kerr, "Propagation of Short Radio Waves," McGraw-Hill Book Co., Inc., New York, N. Y., p. 21; 1951.

Haswell as borne out by both the radio and meteorological data. This conclusion is, in general, borne out by the fact that Haswell fields are above normal during 76 per cent of the time of fadeouts at Karval. For ducts to occur there must be widespread horizontal homogeneity. Therefore, it is reasonable to assume that the atmosphere near the ground in the Karval area is experiencing a degree of modification similar to that measured at Haswell and that the fadeouts at Karval occur simultaneously with increased fields at Haswell. An

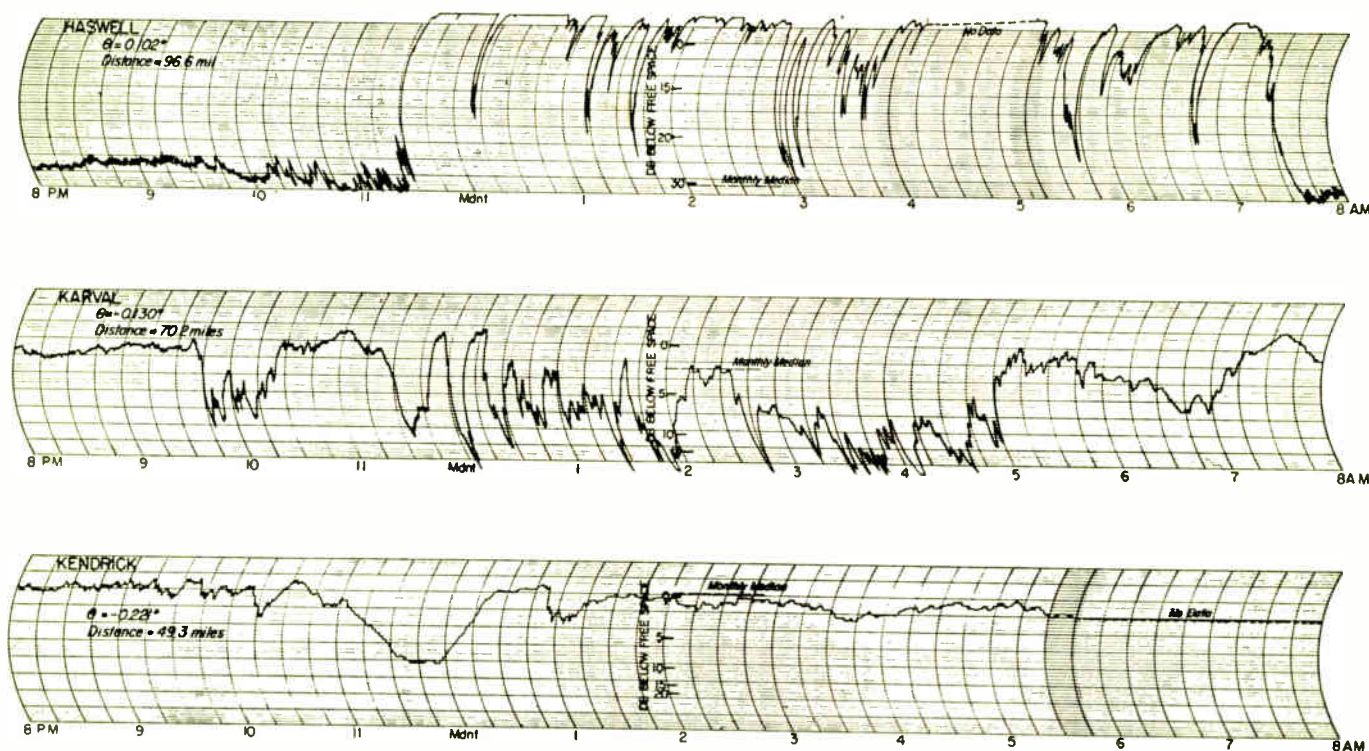

Fig. 8—1,046-mc fields for the night of June 21–22, 1952, at Kendrick, Karval, and Haswell, Colo.

analysis was then made of the radiosonde data of the U. S. Air Force Tornado Project for the period of the project, July 19 through September 26, 1952. The radiosonde data from two of these stations (see Fig. 1) La Junta (47 miles south of the path) and Akron (97 miles north of the path), were analyzed for ground modification and their refractivity profiles classified. The refractivity profiles were classified as (a) linear, provided the refractivity gradients were not in excess of $-0.050 N$ units/meter (i.e., twice the average value for the period of record) and possessed no departures from this degree of linearity within 500 meters above the surface, or (b) ground modified, provided the refractivity gradients were at least $-0.050 N$ units/meter or there existed a layer with a gradient of at least $-0.050 N$ units/meter within 500 meters of the surface. Examples of this classification are found in Fig. 7 where the profiles taken at 1612 and 2035 are linear and those taken at 0945, 2320, 0250, and 0554 are ground modified.

To insure widespread horizontal homogeneity, the La Junta and Akron profiles were used only when both stations had similar profiles. The question then arises as to how long a period of time the profiles are representative of the area. Two analyses were made: (a) for a one-hour time interval with the radiosonde at the mid-point of the time interval, and (b) for a two-hour time interval with the radiosonde observations at the mid-point of the time interval. The nominal observation times are 0800 and 2000 MST.

Table I presents the results of these analyses and shows that, with ground modification present, fadeouts occurred within one hour either side of the radiosonde

observation in 100 per cent of the cases; whereas, in the absence of ground modification (i.e., linear refractivity profile), fadeouts occurred in only 24 per cent of the observation periods. If, however, the time interval is shortened to one-half hour either side of the radiosonde observations fadeouts occurred in 75 per cent of the ground modified observation periods while fadeouts occurred in only 16 per cent of the observation periods with linear profiles.

TABLE I
DEPENDENCE OF PROLONGED SPACE-WAVE FADEOUTS AT KARVAL, COLO., ON THE REFRACTIVITY PROFILES AT LA JUNTA AND AKRON, COLO., FOR THE PERIOD JULY 19, 1952 TO SEPTEMBER 26, 1952.

Time Interval (Radiosonde at the mid-point)	Profile	No. of Observations	Per Cent Occurrence of Fadeouts	Per Cent Occurrence of No Fadeouts
2 Hour	Ground modified	20	100	0
	Linear	25	24	76
1 Hour	Ground modified	20	75	25
	Linear	25	16	84

At present the physical cause of these fadeouts is not clearly understood. The possibility that fadeouts are caused by simple direct- and ground-reflected-wave interference does not seem likely because calculations have proven unsatisfactory in explaining the depth of fadeouts as well as their radio frequency and θ dependence.

In the light of the above meteorological analysis, an extension of Doherty's³ so-called "radio-hole" work would appear to be the most promising approach.

CONCLUSION

In conclusion, then, it would seem that the above analysis indicates that high-transmitter, low-receiver uhf links with θ near zero may be expected to display prolonged space-wave fadeouts providing that there are low-level modifications of the refractivity profile. Consequently, when planning uhf communication and navigational systems intended to operate throughout the

³ L. H. Doherty, "Geometrical Optics and the Field at a Caustic with Applications to Radio Wave Propagation Between Aircraft," School of Electrical Engineering, Cornell University, Ithaca, N. Y., Research Report EE 138; September 10, 1952.

twenty-four hours of the day in all seasons of the year, one should consider the refractivity climatology of the particular area and the transmitter power should be increased enough to insure the degree of reliability required. Detailed meteorological measurements are now being initiated in the Cheyenne Mountain propagation program with the objective of determining more precisely the mechanism causing these fadeouts and the feasibility of extending these conclusions to other areas.

ACKNOWLEDGMENT

The author would like to acknowledge the many helpful suggestions and criticisms of K. A. Norton during the preparation of this paper, and the work of G. J. Haines in the processing of the basic radio data.



CORRECTION

Daniel Levine, author of the paper, "Information Cells on Intensity-Modulated CRT Screens," which appeared on pages 1766-1768 of the December, 1953 issue of the PROCEEDINGS OF THE I.R.E., has brought the following correction to the attention of the editors.

The equations below should read

$$k\lambda > 4. \tag{5}$$

$$Q(x, y) = \frac{\tau\sqrt{\pi}}{k\lambda} I_M e^{-k^2 y}. \tag{6}$$

$$Q(x, 0) = \frac{\tau\sqrt{\pi}}{k\lambda} I_M.$$

$$i(x, y) = I_M e^{-3.67(x^2+y^2)/w^2}. \tag{8}$$

For the sake of completeness it is added that the total beam current, obtained by integration of (8), is

$$i_b = \frac{\pi}{3.67} I_M w^2 = 0.857 I_M w^2,$$

so that the equations may all be expressed in terms of the cathode current; thus, (6) becomes:

$$\begin{aligned} Q(x, y) &= \frac{\sqrt{\pi}}{k v} I_M e^{-k^2 y^2} \\ &= 1.08 \frac{i_b}{w v} e^{-3.67(y/w)^2}. \end{aligned}$$

This form of the equation emphasizes the decrease of excitation for a long pulse when the line width (i.e. spot size) is increased for fixed values of cathode current and sweep speed.

Antenna-Scattering Measurements by Modulation of the Scatterer*

H. SCHARFMAN, ASSOCIATE, IRE,[†] AND D. D. KING, MEMBER, IRE

Summary—An indoor method for measuring the radar cross section of objects by modulating the position of the object is described. The use of synchronous detection and employment of a substitution technique wherein the scattering from an object under test and a known object are measured and compared simultaneously reduce measurement error to ± 2 per cent. The characteristics of the system are discussed, and its advantages and limitations are compared with other systems. Measured curves for the back-scattering cross-section of dipoles for lengths from 0.4λ to 1.6λ show good agreement with other published theoretical and experimental curves. Methods for measuring back-scattering and off-angle scattering from irregular objects by extension of this technique are indicated.

I. INTRODUCTION

AS A CONSEQUENCE of its importance in the radar equation, the absolute value of the back-scattering cross section

$$\left(\sigma = 4\pi \frac{\text{Power scattered back to Source/unit solid angle}}{\text{Incident Power density}} \right)$$

of many objects has been studied both theoretically and experimentally for many years. The inherent mathematical difficulties in the determination of σ for all but the simplest objects place a premium on precise methods of measurement.

Several techniques have been used for the measurement of σ and related parameters. In recent years attention has turned to the use of an image plane for such measurement. Image plane methods have the advantage that errors caused by reflections and lense effects of supports are circumvented. King¹ has employed this device for determination of absorption gain and back-scattering cross section of dipoles. Dike and King² used a similar method for the study of the dipole, and Sevick³ and Aden⁴ made measurements on coupled dipoles and water spheres by means of this technique.

For many purposes these and simpler measurement schemes are adequate. However, use of the image-plane technique limits the investigation to objects having at least one axis of symmetry. Thus scattering investiga-

tions of the objects are confined to study of the back-scattering cross section.

In addition, it has been difficult to achieve high accuracy with the image-plane technique for several reasons. Errors arise due to drift of the source power and frequency, detector sensitivity variations, and noise. Reflections from surrounding objects and walls as well as the finite size and imperfections in the ground plane also cause errors.

As a result, errors of 5 per cent or more are quoted for previous measurements of back-scattering cross section (1, 3). The system described below avoids many of the sources of error mentioned, and also has the capability of measuring both σ and off-angle scattering from irregular objects.

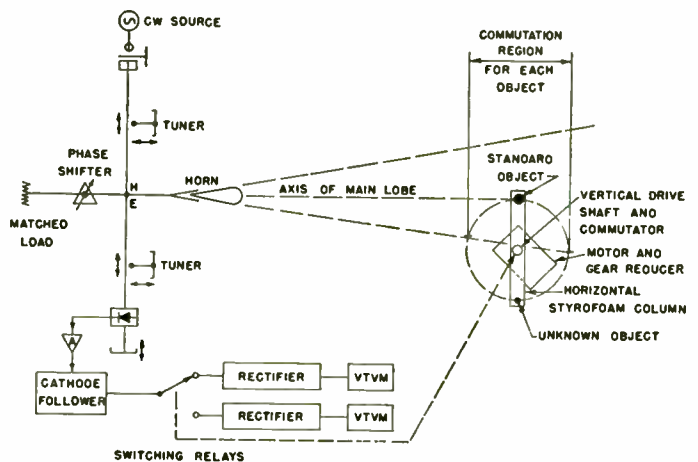

Fig. 1—System block diagram.

II. THE MEASURING APPARATUS

The measurement system is shown in block diagram form in Fig. 1; photographs of the actual equipment set up are shown in Figs. 2, 3, 4 and 5. Referring to Fig. 1, a cw source feeds a slightly unbalanced hybrid tee; the power is divided about equally between the load and horn arms with a small amount of oscillator power entering the detector arm. The power emitted by the horn impinges on a rotating column of styrofoam (dielectric constant ≈ 1.03) in which are embedded a standard such as a metal sphere and opposite it, the object whose σ is to be determined. A synchronous motor and gear reducer drives a vertical wooden shaft which supports the styrofoam column. The horn is located so that its main lobe falls on only one object at a time while the rotation center is kept near the first null of the horn pattern.

As the styrofoam column rotates, each object in turn passes into the main lobe of the horn and scatters back to the horn a quantity of power proportional to its

* Decimal classification: R537.4. Original manuscript received by the I.R.E., August 11, 1953; revised manuscript received December 30, 1953.

The work described in this paper was supported by Contract AF 33(616)-68 between the Wright Air Development Center and the Radiation Laboratory, Johns Hopkins University. This paper is part of a thesis submitted to The Johns Hopkins University by H. Scharfman in partial fulfillment of the requirements for the D.S. in E.E.

[†] Radiation Lab., Johns Hopkins University, Baltimore, Md.

¹ D. D. King, "The measurement and interpretation of antenna scattering," *Proc. I.R.E.*, vol. 37, pp. 770-777; July, 1949.

² S. H. Dike, and D. D. King, "The absorption gain and back-scattering cross-section of the cylindrical antenna," *Proc. I.R.E.*, vol. 40, pp. 853-860; July, 1952.

³ J. Sevick, "An experimental method of measuring back-scattering cross-sections of coupled antennas," *Cruft Lab., Harvard University, Cambridge, Mass., Report 151, May 28, 1952.*

⁴ A. Aden, "Electromagnetic scattering from metal and water spheres," *Cruft Lab., Harvard University, Cambridge, Mass., Report 106, 1950.*

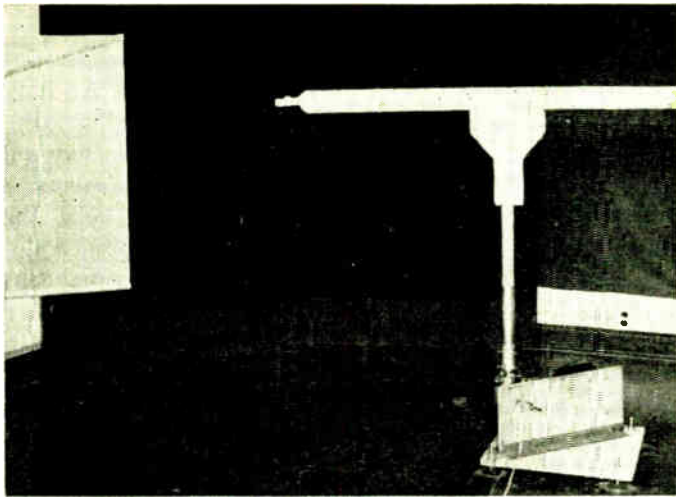

Fig. 2—View of styrofoam column and drive.

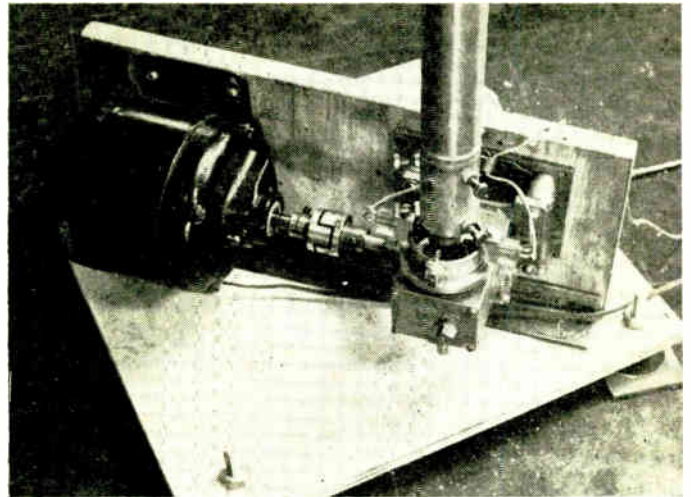

Fig. 3—Close-up of motor, gear reducer, and commutator.

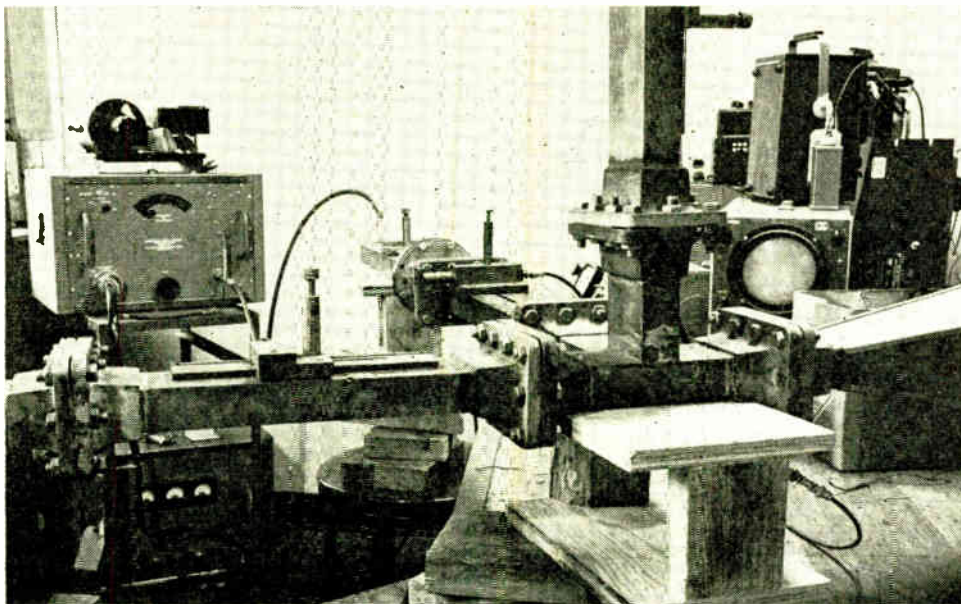

Fig. 4—View of oscillator and waveguide assembly.

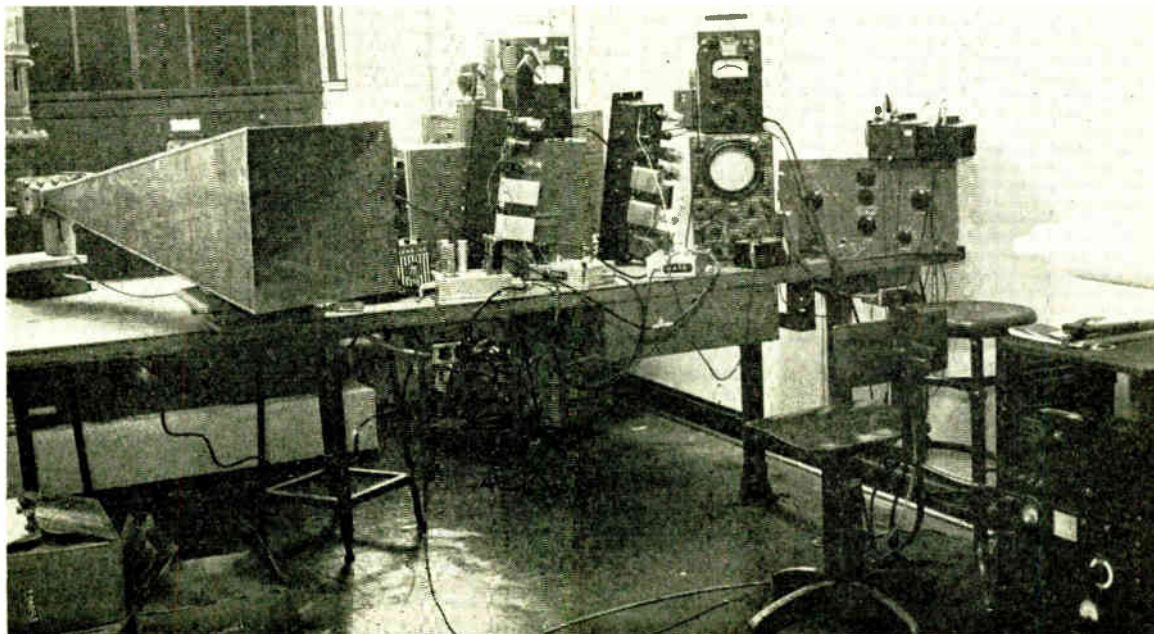

Fig. 5—View of horn and metering equipment

back-scattering cross section. The portion of this signal reaching the detector arm mixes with the oscillator signal and is detected by a crystal. As an object moves into, through, and out of the main lobe, the power scattered back to the horn will vary in amplitude because of the lobe shape and the changing distance, but more important, the phase of the scattered field with respect to the oscillator field will change by π radians for each quarter wavelength of motion parallel to the axis of the horn. For a styrofoam column that is long compared to a wavelength, many phase reversals will occur over the semi-circular swing of the object through the main lobe. Thus, the phase of the back-scattered signal in the detector arm will vary rapidly with respect to the oscillator signal in that arm. The two signals are mixed and detected in the crystal, producing an audio signal corresponding in frequency to the doppler shift caused by the relative motion of the horn and object. In this case the detection process is that of a superheterodyne receiver with an IF equal to the doppler frequency and has been termed Synchronous Detection.^{5,6} Under these conditions, the detector response is linear in that the amplitude of the audio voltage is proportional to the amplitude of the back-scattered field, and the sensitivity is about 30 db better than for direct video detection.

The output of the crystal over a full revolution of the styrofoam column consists of two signals each corresponding to the movement of one of the objects passing through the main lobe of the horn. These signals are independent of each other as only one object is in the main lobe at a time. Double reflection effects and the contribution from objects passing through the side lobes of the horn were observed to be negligible.

The combined signal from the crystal is amplified and the parts corresponding to the standard object and the object to be measured separated by means of relays and a commutator mounted on the vertical drive shaft of the styrofoam column. Commutation is arranged to occur at the time that objects are entering and leaving the main lobe. The separated doppler signals are rectified and averaged over many revolutions of the support column by a long time-constant filter. The two resulting dc voltages appear on a pair of vacuum-tube voltmeters. Each voltage is proportional to the back-scattered field of its respective object. Taking the square of the ratio of the voltages removes the proportionality constants and yields the ratio of the back-scattering cross section of the two objects. The standard scatterer (usually a metal sphere) has a σ that is known exactly^{7,8,9} and the σ for the object under test is determined directly from the measured ratio and known value for the standard.

⁵ M. E. Brodwin, C. M. Johnson, and W. M. Waters, Technical Report 18, Radiation Laboratory, The Johns Hopkins University, Baltimore, Md.; March 31, 1952.

⁶ M. E. Brodwin, C. M. Johnson, and W. M. Waters, "Low level synchronous mixing," 1953 I.R.E. Convention Record, part 10, p. 52.

⁷ J. A. Stratton, "Electromagnetic Theory," p. 563 ff, McGraw-Hill Book Co., New York, N. Y.

⁸ L. N. Ridenour, "Radar System Engineering," p. 64, McGraw-Hill Book Co., New York, N. Y.

⁹ D. Kerr, "Propagation of Short Radio Waves," p. 453, McGraw-Hill Book Co., New York, N. Y.

III. CHARACTERISTICS OF THE SYSTEM

The system as outlined above has several important advantages over others previously employed. As only the ac output of the crystal corresponding to moving objects is amplified and metered, only objects moving through the beam are detected. Reflections from stationary objects including the walls affect only the initial adjustment of the Tee unless the object approaches so close to a highly reflecting object that multiple reflections cannot be neglected. The latter effect is made small by keeping the styrofoam column many wavelengths from the nearest wall and lining the wall opposite the main lobe with absorbing material. The reflected power from this wall is at least 17 db below the incident power at normal incidence. In addition, the specular reflection from the wall opposite the horn was reduced by suitable orientation of the horn with respect to the wall and the styrofoam column.

Potential sources of error arising from variations in oscillator power, detector sensitivity, line voltage and aging effects are avoided by using the previously described time-sharing technique. The scattered field from each object is subject to the same drift effects, and these are eliminated when the ratio of the voltage readings is taken in the process of calculating $\sigma_{\text{test}}/\sigma_{\text{standard}}$. Short-time perturbations are removed by the long-time constant filters at the rectifier outputs.

As described above, synchronous detection is used in the measurements, and this inherently leads to several advantages. It has been shown^{5,6} that about 1 dbm of reference power in the detector arm is needed for good synchronous detection, and that the detection sensitivity is essentially constant over a wide range of reference power. The leniency of these conditions allows the Tee to be properly adjusted by tuning a phase shifter in the matched load arm. This adjustment is insensitive and indicates that the system can be used over wide frequency bands with minor modifications. The crystal detector mount is the only relatively narrow-band element in the system, and this is readily modified for use in different ranges.

By virtue of its linear response, the synchronous detection process indirectly reduces other errors in the system. The crystal-output voltage is proportional to the back-scattered field strength rather than power (as in low-level video detection) and, consequently, the required linear dynamic range of the amplifiers, rectifiers, and voltmeters is reduced. Errors arising from nonlinearities in the latter devices are thus reduced.

IV. LIMITATIONS AND SOURCES OF ERROR

It has been stated above that this system is inherently wide band; the frequency limits will now be considered. The lowest frequency is limited by the physical size of the available range, for the object must always be kept in the Fraunhofer zone (unless one wishes to specifically measure Fresnel-zone scattering). Lower frequencies generally mean physically larger objects and more cumbersome means of getting the standard and unknown ob-

jects in and out of the beam. For outdoor ranges, provision must be made to keep moving objects out of the main lobe, and consideration must be given to the effect of moving objects close to the transmitter in its side lobes. These considerations would appear to limit the minimum frequency to roughly 1,000 mc.

The limitation at high frequencies lies in the support column which inevitably reflects energy and may act as a lens on the standard and unknown objects. At 9,000 mc styrofoam exhibits both of these faults, but measurements at 3,000 mc indicate negligible effects due to the styrofoam. The high frequency limit for high accuracy measurements, therefore, might be about 5,000 mc although usable results could perhaps be obtained at higher frequencies with a specially made support column.

Errors caused by curvature in the phase front of the incident wave over the objects are partly removed when the ratio of the meter readings is taken. This arises from the fact that slight curvature of the phase front will reduce the measured back-scattered signal for both objects.¹⁰ As the error in each signal is in the same direction, the error in their ratio will be smaller than the error in either signal. For objects of approximately the

path traced by the scatterer are also partially cancelled by taking the ratio $\sigma_{\text{test}}/\sigma_{\text{standard}}$.

Errors which cannot be excluded are due to non-linearity of the rectifiers and meters and the meter-reading error which combined should be less than 2 per cent. From intercomparison tests and the excellent repeatability, the over-all probable error in the ratio of the readings for two objects is estimated to be less than ± 1 per cent. As this ratio must be squared to obtain the ratio of the back-scattering cross section, the probable error in the latter ratio is less than ± 2 per cent. The residual errors become more significant for values of σ/λ^2 less than 0.1.

V. EXPERIMENTAL RESULTS

The system of Fig. 1 was set up at 3,000 mc, and the back-scattering cross section of copper dipoles of lengths varying up to $3\lambda/2$ was measured as compared to a silver-painted sphere of radius 1.50 inches. The value of the back-scattering cross section for a sphere as given in the literature^{8,9} was used as the standard. Back-scattering from various sizes of silver-painted spheres was also measured as a check.

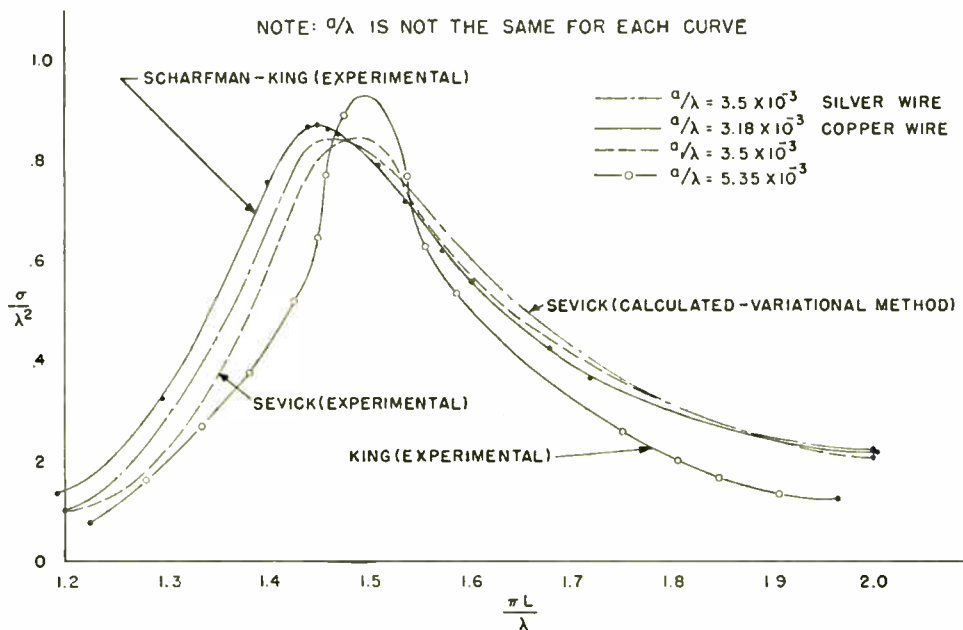

Fig. 6—Back-scattering cross section versus dipole length.

same scattering cross section, the errors tend to cancel completely with high resultant accuracy in the ratio of the signals. By varying the range, it was found that for this system negligible error was incurred if

$$R \cong \frac{(D + d)^2}{\lambda}$$

D = maximum dimension of horn in wavelengths

d = maximum dimension of scatterer in wavelengths

λ = wavelength

R = distance from horn to object on axis of main lobe.

The effects of nonuniform incident amplitude over the

¹⁰ E. H. Braun, "Gain of electromagnetic horns," Proc. I.R.E., vol. 41, pp. 109-115; January, 1953.

In Fig. 6 the measured curve of back-scattering cross section versus dipole length in the vicinity of the first resonance is plotted together with the measured curves of Sevick¹¹ and King¹ as well as the theoretical curve obtained by Sevick¹¹ and Tai¹¹ using the variational method.

In Fig. 7 a measured curve covering the first two dipole resonances is presented along with the measured curves of Dike and King,² Sevick,¹¹ and a theoretical curve by Tai.¹² The absence of a dip before the second

¹¹ J. Sevick, "Experimental and theoretical results on the back-scattering cross-section of coupled antennas," Cruft Lab., Harvard University, Cambridge, Mass. Report 150; 1952.

¹² C. T. Tai, "Electromagnetic back-scattering from cylindrical waves," *Jour. of Appl. Phys.*, vol. 23, pp. 909-916; August, 1952.

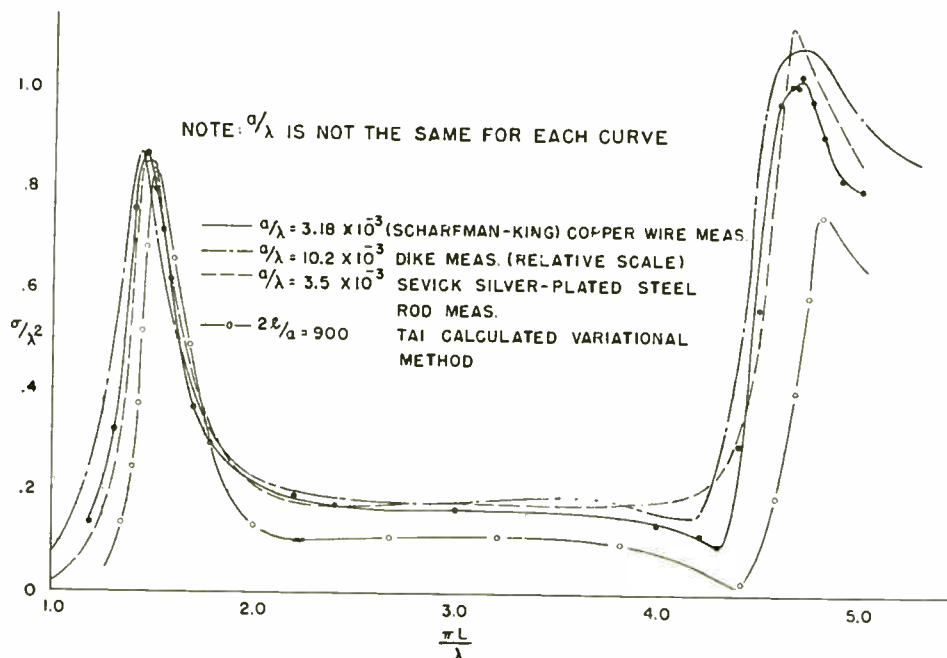

Fig. 7—Back-scattering cross section versus dipole length.

resonance in Sevick's data is ascribed to the high probable error at low values of σ reported by Sevick.

VI. EXTENSIONS OF THE MEASUREMENT METHOD

The technique described above for the measurement of back-scattering cross section has the limitation in common with image-plane techniques that only objects having at least one axis of symmetry can be measured.

Off-angle scattering for arbitrary angles with respect to the horn may be measured by separating the location of receiving and transmitting horns. Reference power for synchronous detection is then supplied from a directional coupler to the remote receiver, and no hybrid junction is required.

The technique of modulating the scatterer is also applicable to image-plane systems. For absorption and loading measurements, as well as for freedom from support problems, the image system is preferable. The standard and test objects would then be mounted in a rotating disk in the image surface, or passed through the beam in some other fashion.

VII. CONCLUSIONS

It has been shown that the system of modulating the scatterer removes many sources of error in back-scattering measurements. Using the described technique, the room-reflection problem is reduced, much of the usual adjustment and tuning difficulties are avoided, and drift caused by electrical and atmospheric changes is eliminated. In addition, the method can be applied over a wide band of frequencies, and has high sensitivity. Data taken on dipole scattering confirm the accuracy of the method, and is in substantial agreement with the results of previous investigations.

With modification the system could be used to measure off-angle scattering, and, by combining some of the features of an image plane, the absorption cross section and the back-scattering cross section of terminated antennas could be measured.

VIII. ACKNOWLEDGMENT

C. F. Miller, M. E. Brodwin, and C. H. Grauling made valuable suggestions to the authors in the course of the work.

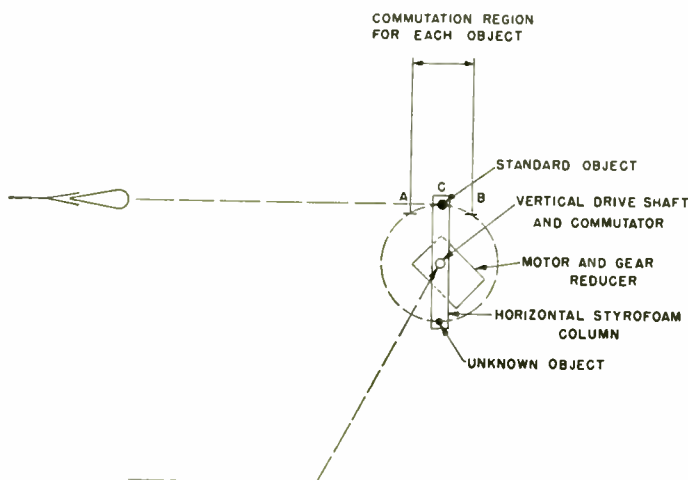

Fig. 8—System for measuring back-scattering from irregular objects.

This restriction is lifted when the commutation period is reduced so that only the signal generated near the center of the main lobe is applied to the rectifier. Scattering from irregular objects may be measured, as indicated in Fig. 8. The orientation of an object with respect to the horn is almost constant from A to B, and the error introduced by slight change in orientation from A to C to B can be varied by changing the commutation period within limits or by increasing the distance from horn to

Correspondence

Improvement of Power Output from Pulsed Klystrons*

A recent paper¹ described the design and performance of high-power pulsed klystron amplifiers which are used on the linear electron accelerator at Stanford University. Recent tests on a modified tube of this type have given considerably higher outputs and improved efficiencies.

Early measurements showed that only 70 per cent of the beam was reaching the collector in this tube. Tests made on a beam tester showed that part of the beam was lost at the anode surface, and that by increasing the cathode-anode distance slightly and enlarging the taper at the entrance to the drift tube, the transmission would be greatly improved. These changes, made on a tube which had been provided with an insulated collector, resulted in a transmission of 90 per cent. The actual transmission through the active portion of the tube is somewhat higher, since the insulated collector is located some distance from the last cavity in the tube.

However, with these changes the tube oscillated violently at a frequency of about 5,800 mc (which is not a harmonic frequency). This oscillation made it impossible to measure the performance accurately, since directional couplers were used for power measurement. Cold tests of the cavity showed that a higher mode of the correct frequency was responsible for the oscillation. The feedback mechanism has not been determined; it probably takes place either by fast secondaries or by rf coupling through the drift tube. The latter seems improbable, since the attenuation between cavities is greater than 25 db at this frequency.

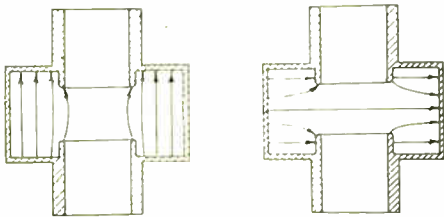

Fig. 1—Cavity modes at 10.5-cm (left) and 5.2-cm wavelengths.

The two cavity modes are shown in Fig. 1. By inserting two plates as shown in Fig. 2, it was possible to suppress the oscillation mode without affecting the fundamental resonance by a significant amount. This modification (made in the middle cavity, which has the highest Q) has effectively stopped the oscillation.

The modifications have been made on two tubes, one of which has been tested at a beam voltage of 360 kv. At this level, the tube gave an output of 30 megw with an efficiency of 41 per cent. The rf pulse length was 1.4 μ sec and the repetition frequency

was 60 cps. (The beam pulse length was 2 μ sec, so that a 2- μ sec rf pulse could have been used, had a driver been available.) The second tube was tested to 25 megw and then placed in operation on an accelerator, where it has been in use for the past six months.

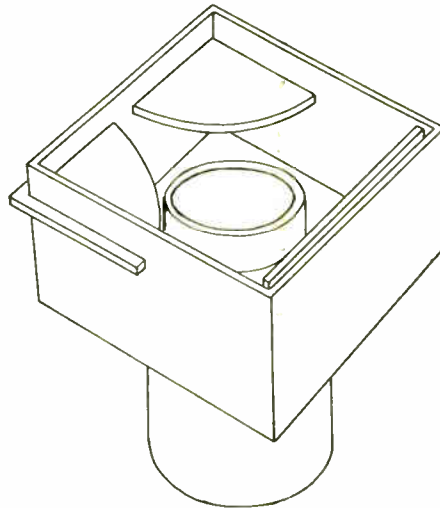

Fig. 2—Cut-away view of cavity, showing oscillation suppressors.

It is believed that the power limit on this tube has not been reached, since unmodified tubes have been operated as diodes up to 400 kv at 1.5 μ sec. The present modulator does not allow variation of the pulse rate, but it should be possible to increase the rate somewhat, since the cooling is adequate. Increasing the pulse length, on the other hand, would almost certainly require redesign of the collector, to prevent melting; possibly the cathode would also need modification. The efficiency should remain about the same, since it was increasing slightly at the highest voltage used.

The above investigations were carried out at Stanford University under the sponsorship of the Office of Naval Research, Contract N6onr 25123. The cold testing and modification of cavities was carried out by K. L. Brown.

JOHN H. JASBERG

W. W. Hansen Laboratories of Physics
Stanford University
Stanford, Calif.

A Simple Graphical Analysis of a Two-Port Waveguide Junction*

The results presented in the subject paper;¹ evaluation of scattering coefficients and measurement of a load through a junction, are justified² by means of elementary geometry. The authors seem to believe that

* Received by the Institute, November 23, 1953.

¹ J. E. Storer, L. S. Sheingold, and S. Stein, *Proc. I.R.E.*, vol. 41, pp. 1004-1013; Aug., 1953.

² An analytical justification, also elementary, of the evaluation of the scattering coefficients can be found in G. A. Deschamps, "Determination of the reflection coefficients and insertion loss of a waveguide junction," *Jour. of App. Phys.*, vol. 24, pp. 1046-1050; Aug., 1953. It was also available in the reports quoted in Footnote 1 of Ref. 1.

justification at a higher level could make the constructions for the second problem more complicated. It is doubtful, however, whether the average engineer is more familiar with the properties of inversion than with those of so-called higher geometry. He could probably become acquainted just as easily with the latter, and thus improve his ability to solve other problems on waveguide junctions. The main acquisition would be the concept of hyperbolic distance.³ This special distance does not have to be introduced, any more than ordinary distance, by way of group theory or other relatively obscure mathematical techniques; it is merely the result of taking a reading with the hyperbolic protractor.⁴

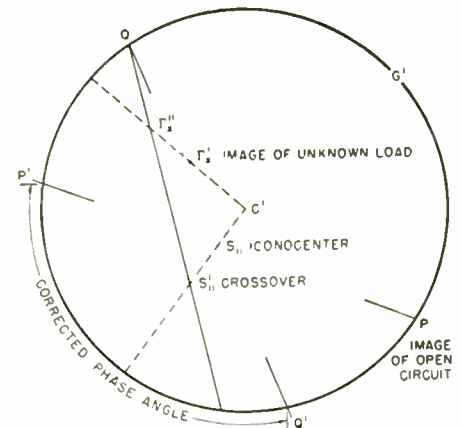

Fig. 3

With these tools available, the procedure for interpreting the measurements of an obstacle through a junction, lossy or not, is greatly simplified.⁵ Using, to make comparison easier, the notation of Ref. 1, Fig. 4 of that reference is reduced to the accompanying Fig. 1. The point Γ_z'' is constructed by the transformation \mathcal{B} relative to G' (Ref. 3, section 1). The corrected VSWR in decibels is then the hyperbolic distance between S_{11}' and Γ_z'' , and can be obtained by a single reading with the protractor. (Compare to formula for $|\Gamma_z|$ on Fig. 4, Ref. 1, which involves 3 measurements of length.) The corrected phase angle is $P'Q'$, obtained by projecting P and Q through S_{11} (no necessity to determine first the phase angle of S_{22}).

It should be noted that since this construction always remains inside the circle G' , there is no need for an alternative construction such as that of Fig. 5, Ref. 1.

G. A. DESCHAMPS
Federal Telecommun. Labs.
International Tel. and Tel. Corp.
Nutley, N. J.

³ G. A. Deschamps, "New chart for the solution of transmission line and polarization problems," *Trans. I.R.E. Professional Group on Microwave Theory and Techniques*, vol. 1, pp. 5-13; March, 1953. Also *Elect. Commun.*, vol. 30, pp. 247-254; Sept., 1953.

⁴ G. A. Deschamps, "A hyperbolic protractor for microwave impedance measurements and other purposes," *International Tel. and Tel. Corp.*, 67 Broad Street, New York, N. Y.; 1953.

⁵ Ref. 3, sect. 6 and 7.

* Received by the Institute, February 1, 1954.
¹ M. Chodorow, E. L. Ginzton, I. R. Neilsen, and S. Sonkin, "Design and performance of a high-power pulsed klystron," *Proc. I.R.E.*, vol. 41, pp. 1584-1602; November, 1953.

Correspondence

One Way Transmission Devices*

It might seem possible to use the non-reciprocal properties of ferrites to make lossless one-way transmission devices at



Fig. 1

microwave frequencies. For example, in the two-terminal-pair circuit shown below, energy fed in at terminals 1 would be transmitted to terminals 2 with minimum loss, whereas energy impressed on terminals 2 would be totally reflected. However, this characteristic is impossible because of the principle of conservation of energy. This can be proven in Fig. 1 above:

If our network is lossless, all the energy entering the network minus the energy leaving must total up to zero. In equation form this can be written as:

$$\sum_n (a_n a_n^* - b_n b_n^*) = 0. \quad (1)$$

The quantity, a_n , represents the amplitude of the incident wave entering the n th terminal, whereas the quantity, b_n , represents the amplitude leaving the n th terminal. The relation between the entering and the leaving amplitudes can be expressed as follows:

$$\begin{aligned} b_1 &= s_{11}a_1 + s_{12}a_2 \\ b_2 &= s_{21}a_1 + s_{22}a_2. \end{aligned} \quad (2)$$

Since the terms $a_1 a_1^*$, $a_2 a_2^*$, etc., are independent, their coefficients obtained in the substitution of (2) into (1) must be equal to zero or:

$$\begin{aligned} 1 - s_{11}s_{11}^* - s_{21}s_{21}^* &= 0 \\ 1 - s_{22}s_{22}^* - s_{12}s_{12}^* &= 0 \\ s_{11}s_{12}^* - s_{21}s_{22}^* &= 0 \\ s_{12}s_{11}^* - s_{22}s_{21}^* &= 0. \end{aligned} \quad (3)$$

These are the unitary relations shown in the reference.¹

Let it be assumed that terminal pair 1 is matched for a matched load on terminal pair 2, i.e., $s_{11} = 0$. Then it follows from the first unitary equation that:

$$|s_{21}| = 1.$$

The third equation shows that

$$|s_{22}| = 0$$

or that no reflections appear at terminal 2 if a matched load is placed on terminal one. Further, it is seen that

$$|s_{21}| = |s_{12}| = 1$$

which means that if the device transmits in one direction, it must transmit for the other direction as well.

If the network is a perfect reflector at one terminal, i.e., $|s_{11}| = 1$, it can be shown that a perfect reflection occurs at the other terminal.

As a converse to the above, a passive one-way transmission device must have dissipation. Nonreciprocal devices having minimum forward loss and high absorption in the reverse direction have been demonstrated and do not contradict the above explanation.

ALLEN E. SMOLL
General Electric Co.
Syracuse, New York

If the cut-off frequencies are f_1 and f_2 and the frequencies at the discontinuity f' and f'' , the equation from which a curve of this type may be plotted is of the general form

$$x = \log f \left| \frac{f'}{f_1} + Kf \right| \frac{f_2}{f''}$$

where K is a constant and x the linear scale co-ordinate. If the discontinuity here could be approximated by a continuous function, a practical formula for scale division may result from which curves similar to the one in Fig. 1b may be plotted, free from discontinuity.

The following suggestion for a solution dodges the discontinuity by replacing the linear scale with a stretched logarithmic scale, see Fig. 1(c), the stretching being accomplished by doubling (or quadrupling) the length of the decade from a chosen mid-frequency, here mc. As is seen, the resulting continuous curve is a good approximation of the discontinuous curve in Fig. 1(b). If the decade Δf_{\log} fits the plotting paper, the decade $\Delta f_{str.\log}$ also fits the plotting paper. If it is desirable also to show the lower cut-off region in detail, two-way stretching from the assumed mid-frequency may be employed, leaving the least interesting, flat portion of the response curve compressed to a small part of the graph. Modern 1,000-mc distributed amplifiers have such a region, which is made insignificant by this method,

Stretched-Log Frequency Axis*

In wide-band amplifiers with six, or more, frequency decades, a logarithmic scale frequently prevents adequate plotting of hf wiggles and cut-off conditions, as is born out by the exaggerated distributed amplifier response curve in Fig. 1(a). As a remedy,

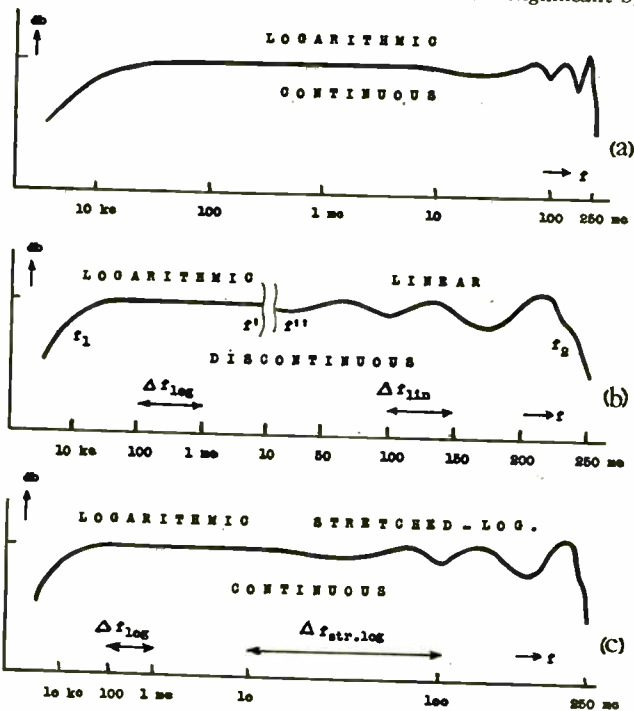

Fig. 1

the response curve is conventionally broken off at some point and continued linear, as is shown in Fig. 1(b). Occasionally, a wiggle in the curve gets lost by this procedure, and if the decade Δf_{\log} fits the plotting paper, the decade Δf_{110} may not fit it.

while the important wiggles and drops are enhanced in continuous presentation. The same technique applies to associated phase and time delay characteristics.

To the extent printed stretched logarithmic paper is available, the above procedure simplifies to straightforward logarithmic plotting.

* Received by the Institute, July 17, 1953.

* Received by the Institute, January 25, 1954.
¹ C. G. Montgomery, et al., "Principles of Microwave Circuits," vol. 8, Radiation Lab. Series, p. 149; 1948.

Correspondence

One may argue the point that the curve in Fig. 1(c) is not continuous, as it appears to the eye, due to the fact that in the transformation from decade to decade, the coefficients for the higher order derivatives in the appropriate Taylor's series obtain new numerical values. This is not true, for we are still dealing with the original analytical function, but the eye must get used to reading scale-implied slope changes without hesitation.

HARRY STOCKMAN
Electronics Consultant
Waltham, Mass.

A New Method of Driving-Point Impedance Synthesis*

R. Bott and R. J. Duffin¹ have indicated a method of driving point impedance synthesis that eliminates the coupled inductors required in the Brune realization of a minimum immittance function. Their technique is to solve for $Z(p)$ in the function

$$R(p) = \frac{kZ(k) - pZ(p)}{kZ(p) - Z(k)p}, \quad (1)$$

which Richards² had showed to be positive-real if $Z(p)$ is positive-real. $Z(p)$ is thereby written as a sum of two positive-real functions, each of which can be reduced to an order two less than the order of $Z(p)$.

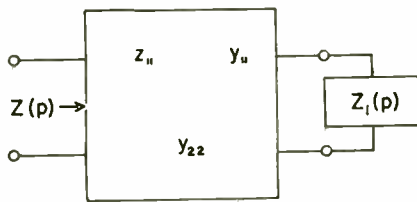

Fig. 1

Richards's function can also be used quite differently in a two-terminal-pair approach to driving-point impedance synthesis. In Fig. 1

$$Z_1(p) = \frac{z_{11} [1 - Z(p)y_{11}]}{y_{22} [Z(p) - z_{11}]} \quad (2)$$

Give z_{11} that $Z(p)$ is minimum, and $ReZ(j\omega_0) = 0$, let $Z(j\omega_0) = j\omega_0 L_0$, and assume $L_0 > 0$. Arbitrarily, let

$$z_{11} = pL_0 + \frac{k^2 L_0}{\frac{k^2 L_0 - pZ}{Z - pL_0} + \frac{\omega_0^2 p}{p^2 + \omega_0^2}} \quad (3)$$

in which

$$k = \frac{Z(k)}{L_0}$$

Since

$$\frac{k^2 L_0 - pZ}{Z - pL_0}$$

is a Richards function, z_{11} is positive-real. Now z_{11} can be synthesized as in Fig. 2. Let

$$\frac{k^2 L_0}{\frac{k^2 L_0 - pZ}{Z - pL_0} - \frac{Ap}{p^2 + \omega_0^2}} = Z_2(p). \quad (4)$$

Here A is a constant which, if the elements of z_{11} are to be positive, must conform to

$$A \leq 2 \text{ Residue} \left[\frac{k^2 L_0 - pZ(p)}{Z(p) - pL_0} \right]_{p=j\omega_0} \quad \text{for } A > 0, \quad (5)$$

or

$$A > (-\omega_0^2) \text{ for } A < 0.$$

$Z_2(p)$ has in general a zero at $p = j\omega_0$ and thus can be reduced to an order two less than the order of $Z(p)$.

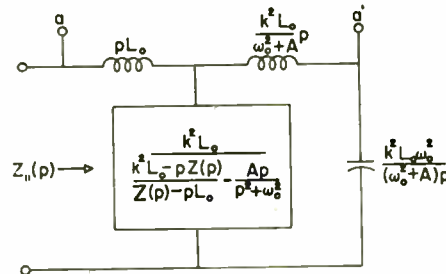

Fig. 2

$Z_1(p)$ can now be calculated with some labor from (2), this terminating network being placed across $a-a'$:

$$Z_1(p) = \frac{L_0 [L_0 k^2 - pZ(p)]}{Z(p) - pL_0} + \frac{k^2 L_0 A p}{(\omega_0^2 + A)(p^2 + \omega_0^2)} \quad (6)$$

If

$$\frac{k^2 A}{\omega_0^2 + A} \geq -2 \text{ Residue} \left[\frac{L_0 k^2 - pZ(p)}{Z(p) - pL_0} \right]_{p=j\omega_0} \quad (7)$$

then $Z_1(p)$ is positive real. $Z_1(p)$ has in general a pole on the $j\omega$ -axis at $p = j\omega_0$ and so can be reduced to an order two less than the order of $Z(p)$. There are two important values for A :

$$\text{I. } \frac{k^2 A}{\omega_0^2 + A} = -2 \text{ Residue} \left[\frac{L_0 k^2 - pZ(p)}{Z(p) - pL_0} \right]_{p=j\omega_0} \quad (8)$$

Although A is negative, it is obvious from (8) that $A > (-\omega_0^2)$ and so the elements of Fig. 2 are positive.

$$\text{II. } A = 2 \text{ Residue} \left[\frac{k^2 L_0 - pZ(p)}{Z(p) - pL_0} \right]_{p=j\omega_0} \quad (9)$$

Under condition I, the pole at $j\omega_0$ in $Z_1(p)$ is removed and so $Z_1(p)$ is of order two less than that of $Z(p)$; $Z_2(p)$ can be reduced as previously indicated. Under condition II, zero at $p = j\omega_0$ is removed and so $Z_2(p)$ is of order two less than that of $Z(p)$; $Z_1(p)$ can be reduced as indicated before.

In each case the reduction is accomplished with one less element per reduction cycle than in the Bott-Duffin method, and

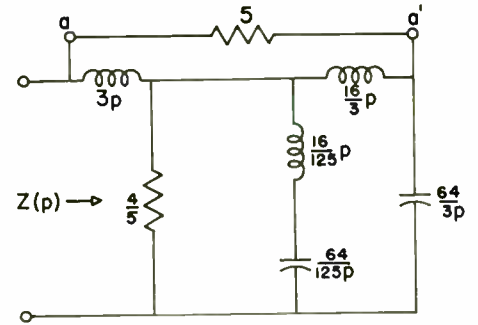

Fig. 3

no mutual inductance is used. If $L_0 < 0$, duality leads to a corresponding realization. As an example, let

$$Z(p) = \frac{5p^2 + 18p + 8}{p^2 + p + 10}$$

From which

$$\omega_0 = 2, \quad L_0 = 3, \quad \text{and } k = 2/3,$$

all units being in the usual practical MKS system for impedance. The realization under condition I is shown in Fig. 3; that under condition II in Fig. 4; the Bott-Duffin synthesis leads to Fig. 5.

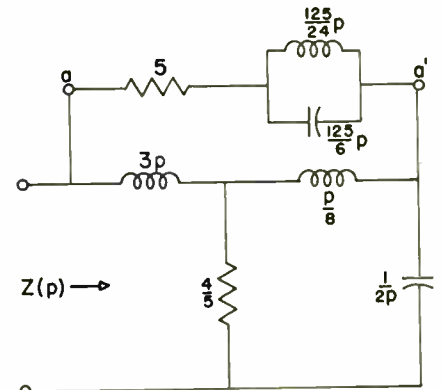

Fig. 4

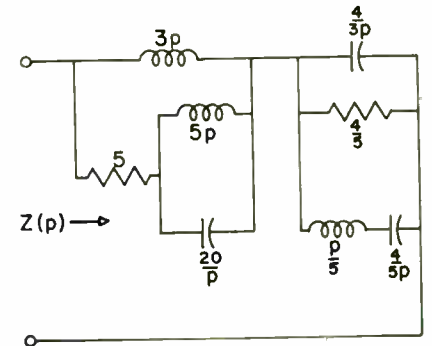

Fig. 5

This procedure is a result of work done with the support of the U. S. Army, U. S. Air Force, and U. S. Navy. A more detailed discussion of this and other new synthesis techniques is in preparation.

R. H. PANTELL
Electrical Engineering Dept.
Stanford University
Stanford, Calif.

* Received by the Institute, January 19, 1954.
¹ R. Bott and R. J. Duffin, "Impedance synthesis without use of transformers," *Jour. Appl. Phys.*, vol. 20, p. 816; Aug., 1949.
² P. I. Richards, "A special class of functions," *Duke Math. Jour.*, vol. 14, pp. 777-786; 1947.

Correspondence

The Effect of Space Charge on Beam Loading in Klystrons*

In the usual derivation of klystron beam loading, the effect of space charge is neglected.¹ It is desirable to know whether this assumption is justified and to determine under what beam conditions space charge can no longer be ignored. An interesting by-product of this investigation is a new explanation for the excessive beam loading caused by secondary electrons.

A very general solution of the diode loading problem has been obtained by Llewellyn and Peterson² which is readily applicable to the problem at hand. Their equation (16) gives the impedance of a diode with any degree of space charge between the input and output planes. The last term of (16) may be written as $-i2\zeta(1-\zeta)(\sqrt{V_{Da}} + \sqrt{V_{Db}})^2/I_D\theta$ in which case the general diode impedance is given by

$$Z = r_0 \left[\frac{r}{r_0} + i \frac{x}{r_0} - i \frac{3(1-\zeta)}{\zeta} \frac{1}{\theta} \right], \quad (1)$$

where

$$r_0 = 2\zeta^2(\sqrt{V_{Da}} + \sqrt{V_{Db}})^2/3I_D$$

$$\frac{r}{r_0} = 12[2(1-\cos\theta) - \theta \sin\theta]/\theta^4$$

$$\frac{x}{r_0} = -12[(\theta^3/6) + \theta(1+\cos\theta) - 2\sin\theta]/\theta^4$$

V_{Da} = dc voltage at entrance plane *a*

V_{Db} = dc voltage at exit plane *b*

I_D = dc current density, amperes/cm²

θ = electron transit angle between *a* and *b* planes.

The factor ζ specifies the degree of space charge between the *a* and *b* planes. It is related to the ratio of the direct-current density I_D to the limiting-current density that can pass between the planes without electron reversal I_m . Llewellyn and Peterson² give a cubic equation relating ζ and I_D/I_m . This equation may be solved algebraically for ζ . Discarding extraneous roots, we find

$$\zeta = \begin{cases} 2[1 - \cos(\frac{1}{3} \cos^{-1} |1 - 2I_D/I_m|)] & 0 \leq I_D/I_m \leq \frac{1}{2} \\ 2[1 + \cos(\frac{1}{3} \cos^{-1} |1 - 2I_D/I_m| + 120^\circ)] & \frac{1}{2} \leq I_D/I_m \leq 1. \end{cases} \quad (2)$$

The limiting-current density is given by the expression

$$I_m = \frac{2.33}{10^6} \frac{(\sqrt{V_{Da}} + \sqrt{V_{Db}})^3}{X^2} \quad (3)$$

where I_m is in amperes/cm², V_D is in volts, and gap spacing X is in cm.

In a klystron gap it is customary to calculate admittance rather than impedance, hence it is useful to invert and rationalize (1). If we let $V_{Da} = V_{Db} = V_D$, the conductive component of the admittance may be written as

$$g = \frac{I_D}{V_D} \frac{3}{8} \frac{1}{\zeta^2}$$

* Received by the Institute, September 23, 1953.
¹ D. R. Hamilton, J. K. Knipp, and J. B. H. Kuper, "Klystrons and Microwave Triodes," McGraw-Hill Book Co., Inc., New York, N. Y., p. 54; 1948.

² F. B. Llewellyn and L. C. Peterson, "Vacuum-tube networks," Proc. I.R.E., vol. 32, pp. 144-166; March, 1944.

$$\frac{\frac{r}{r_0}}{\left(\frac{r}{r_0}\right)^2 + \left[\frac{x}{r_0} - \frac{3(1-\zeta)}{\zeta} \frac{1}{\theta}\right]^2} \quad (4)$$

For small space charge the last term in the denominator predominates and (4) becomes simply

$$g = \frac{I_D}{V_D} \frac{1}{2\theta^2} [2(1 - \cos\theta) - \theta \sin\theta] \frac{1}{(1-\zeta)^2}$$

Except for the last factor, this is identical with the beam loading result derived by the nonspace-charge method. Thus the presence of a small amount of space charge merely scales up the customary loading by the factor $1/(1-\zeta)^2$.

$\zeta=0.0049$. According to (5), the space-charge correction is only 1 per cent under these conditions, so space charge is truly negligible in the calculation of primary electron beam loading.

It is interesting to consider the effect of space charge on secondary electron beam loading. The majority of secondary electrons in a small-signal gap travel with extremely small velocities. As a first approximation let us consider that all secondaries are emitted with 5 volts of energy into a 0.100 inch gap. From (3) the limiting current density for these electrons is 3.24 ma/cm². This current density would be attained if a 100 ma/cm² primary beam suffered only 3.24 per cent interception. From this calculation it seems likely that the

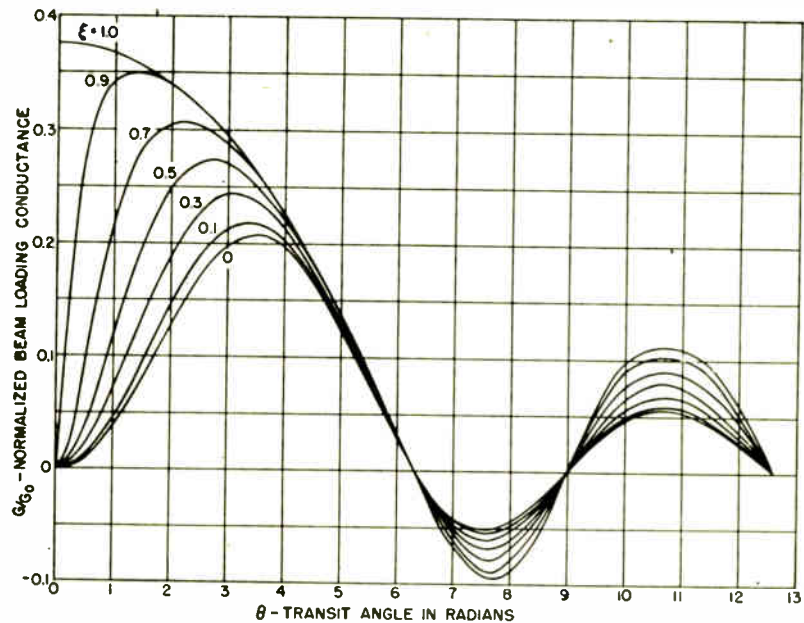

Fig. 1—Normalized beam loading conductance for various degrees of space charge.

Equation (4) is plotted in Fig. 1 for several values of the parameter ζ . The curve for $\zeta=0$ is the familiar primary beam-loading curve for klystrons. The most interesting characteristic of the other curves is the order of magnitude increase of beam loading at small transit angles and large degrees of space charge. It is also significant to note that when complete space charge prevails a virtual cathode is established and loading takes on a new characteristic. No longer is transit time necessary for loading to take place. Indeed, loading is most severe at zero transit angle. This, of course, is typical of the loading found in diodes and grounded-grid triodes where complete space-charge conditions usually exist.

To see whether space charge alters primary beam loading appreciably in a klystron gap, it is necessary only to calculate ζ for typical conditions. Let $V_D = 1,000$ volts, and $X = 0.100$ inch; then from (3) $I_m = 9.13$ amps/cm². If a typical value for I_D is 0.1 amp/cm², $I_D/I_m = 0.011$, and from (2)

space-charge factor for secondaries is quite large. It is possible that a virtual cathode of secondary electrons could be set up in the center of the gap. Electrons coming to rest there would not be reflected immediately but would leave in response to an applied rf voltage and thus cause heavy loading. Secondaries of different energies would either pass through the virtual cathode or be reflected before they reach it. In either case they would be traveling under heavy space-charge conditions and their loading would be correspondingly increased. Loading would be especially severe in the case of small transit angles and large degrees of space charge, as Fig. 1 shows. In view of these results it seems likely that a successful theory of secondary electron beam loading definitely must include the effect of space charge.

T. G. MIHRAN
 Research Laboratory
 General Electric Co.
 Schenectady, New York

Contributors

J. Aarons (S'44-A'51) was born on October 3, 1921 in New York, N. Y. He received a B.S. degree in education from the City College of New York in 1942. In 1949 he received an M.A. in physics from Boston University.



J. AARONS

During the Second World War he was a member of the U. S. Air Force, he took a radar course at Harvard and M.I.T. and served as radar officer.

Mr. Aarons was employed from 1946-1953 as a physicist by the Geophysics Research Directorate, Air Force Cambridge Research Center, where he did research in solar noise and low frequency magnetic fluctuations of the earth's field.

At present Mr. Aarons is on leave from the Cambridge Research Center to do research as a Fulbright grantee at the Sorbonne and the Laboratory of the Physics of the Atmosphere in Paris.

He is a member of RESA.



B. R. Bean was born September 14, 1927 in Boston, Mass. He earned a B.S. in Meteorology from the University of New Hampshire in 1949. He worked for the U. S. Weather Bureau Station at Durham, N. H. from 1945-1949.



B. R. BEAN

In March, 1950 Mr. Bean transferred to the Central Radio Propagation Laboratory of the National Bureau of Standards.

Since then he has been doing research on radio meteorology. He is now in charge of radio meteorological operations and analysis group.

Mr. Bean is a professional member of The American Meteorological Society.



T. J. Bridges was born at Gillingham, Kent, England in December, 1923. He was educated at Maidstone Grammar School and London University where he received the B.Sc. (Eng.) degree from London University in 1944.



T. J. BRIDGES

He joined the Admiralty in 1945 and is at present a member of the Royal Naval Scientific Service at the Services Electronics Research Laboratory, Baldock, England.

I. Gumowski was born in Poland on March 28, 1928. He received the B.Sc. degree in electrical engineering from Laval



I. GUMOWSKI

University, Quebec, P. Q., in 1951. For a period in 1951 he was employed as an engineer in the Transmission and Development Laboratory of the Canadian Broadcasting Corporation in Montreal, but returned to Laval University to continue his studies. In 1952 he received the

M.Sc. degree, and in 1953 he completed the research required for the D.Sc. degree, while working on a project sponsored by the Defense Research Board of Canada. At present he is a member of the teaching staff at Laval University. Mr. Gumowski is also a registered professional engineer in the province of Quebec.



K. W. Harrison (SM'52) was born in London, England, in 1911. He studied mechanical and electrical engineering at the Borough and Regent Street Polytechnics, and in 1933 passed the graduateship examination of the Institution of Electrical Engineers. He became an associate member in 1938.



K. W. HARRISON

At the end of 1930, after two and a half years with Standard Telephones and Cables, Mr. Har-

rison joined the Telephone Manufacturing Company. In 1940 he was sent to India to supervise installation of carrier systems and later, served as a Major in the Royal Signals.

In 1946 Major Harrison took up an appointment with the East African Posts and Telegraphs, returning to the Telephone Manufacturing Company in 1949, where he is now head of the Line-Transmission Department and responsible for the design, development and planning of transmission systems.



R. H. Kingston (S'48-A'52) was born in Somerville, Massachusetts, on February 13, 1928. He received the B.S. and M.S. degrees in Electrical Engineering from the Massachusetts Institute of Technology in 1948. Under the co-operative plan in electrical engineering during the years 1945 to 1948, he worked at the Philco Corporation on

component testing, radar system design, and (research on) frequency modulation and circuit theory. In June, 1951 he received the



R. H. KINGSTON

Ph.D. degree in Physics from M.I.T., where his major field was the physics of solids. He joined the staff of the Lincoln Laboratory at M.I.T., at this time, where he has been engaged in transistor research and development. From September, 1951 to September, 1952, on

leave of absence from the Lincoln Laboratory, he was a member of the technical staff at Bell Telephone Laboratories in New Jersey.



J. T. Mendel (S'49-A'51) was born in Palo Alto, Calif., on March 10, 1928. He attended Stanford University from 1945-1952,



J. T. MENDEL

receiving the B.S. degree in electrical engineering in 1949, the M.S. degree in 1950, and the Ph.D. degree in 1952. In 1951-52 he held an Atomic Energy Commission Fellowship at Stanford University.

Since 1952 he has been a member of the technical staff, Bell Telephone Laboratories, Murray Hill, N. J.

Dr. Mendel is a member of Tau Beta Pi, Sigma Xi, and Phi Beta Kappa.



R. L. Pritchard (S'45-A'51) was born in Irvington, N. J., on Sept. 8, 1924.

He attended M.I.T. on the V-12 program. He graduated from Brown University in 1946 with a B.S. degree. In 1947, he received the M.S. degree from Harvard. He received the Ph.D. degree in acoustics at Harvard in 1950.



R. L. PRITCHARD

Since then, he has been with General Electric Research Lab. in Schenectady,

working on communication and acoustic projects. For the past three years he has been doing research on the transistor from an electric-circuit point of view.

Dr. Pritchard is a member of the Acoustical Society of America and Sigma Xi.

Contributors

C. F. Quate (S'43-A'50) was born on December 7, 1923, in Baker, Nev. He received the B.S. degree from the University of Utah in 1944, and the Ph.D. in electrical engineering from Stanford University in 1949.



C. F. QUATE

In 1949 he joined the Bell Telephone Laboratories, Murray Hill, N. J., as a member of the technical staff engaged in research on microwave tubes.

Dr. Quate is a member of Tau Beta Pi, and Sigma Xi.

J. Shekel (A'52) was born in Bialystok, Poland on January 6, 1926. He received his engineering education at the Hebrew Institute of Technology in Haifa, Israel, and graduated with the degree Ingénieur (E.E.) in 1951.



JACOB SHEKEL

After his graduation, Mr. Shekel was employed by the Scientific Department of the Ministry of Defense of Israel, where he does research and development work on electronic projects. Mr. Shekel works in the fields of network analysis and synthesis,

and ultra-high-frequency techniques. Since February of 1953, Mr. Shekel has been a visiting lecturer in engineering at the Israel Institute of Technology, in Haifa, in addition to his regular Ministry of Defense duties.

During the summer of 1949 Mr. Shekel came to the United States and was a guest student on the Foreign Students Summer Project at the Massachusetts Institute of Technology. While he was there he took a course on microwaves.

W. H. Yocom was born in Oberlin, Ohio, on May 15, 1919. He attended Oberlin College receiving the B.A. degree in Physics in 1940. He received the B.S. degree in electrical engineering from the Massachusetts Institute of Technology in 1942.



W. H. YOCOM

In 1950 he received the M.S. degree in electrical engineering from Stevens Institute of Technology. Since 1942 Mr. Yocom has been employed by Bell Telephone Laboratories, Murray Hill, N. J. Mr. Yocom is concerned with the various aspects of carrier and microwave system development, including the design of testing equipment. Since 1952 he has been engaged in research in the field of microwave electronics.

He is currently investigating backward-wave oscillators for millimeter waves.

Mr. Yocom holds membership in Sigma Xi.

A. H. Zemanian (A'51) was born on April 16, 1925, in Bridgewater, Massachusetts. He received the B.E. degree from the College of the City of New York in 1947.



A. H. ZEMANIAN

He received the M.F.E. and the Eng. Sc. D. degrees in 1949 and 1953, respectively, from New York University. He was an instructor in the electrical engineering department of the College of the City of New York for the academic year 1947-1948. He also was an inspector of electrical circuit installation for the Board of Transportation in New York. He then joined the Maintenance Co., New York, N. Y., as an engineer, where his duties included the design and supervision of the electrical phases of contracting jobs on electric elevators. Since 1952, he has been an instructor in the electrical engineering department of New York University.

Dr. Zemanian is an associate member of the AIEE. He also holds membership in Tau Beta Pi, and Eta Kappa Nu. He holds a professional engineering licence from the state of New York.

1954 ENGINEERING SHOW LARGEST IN IRE'S HISTORY

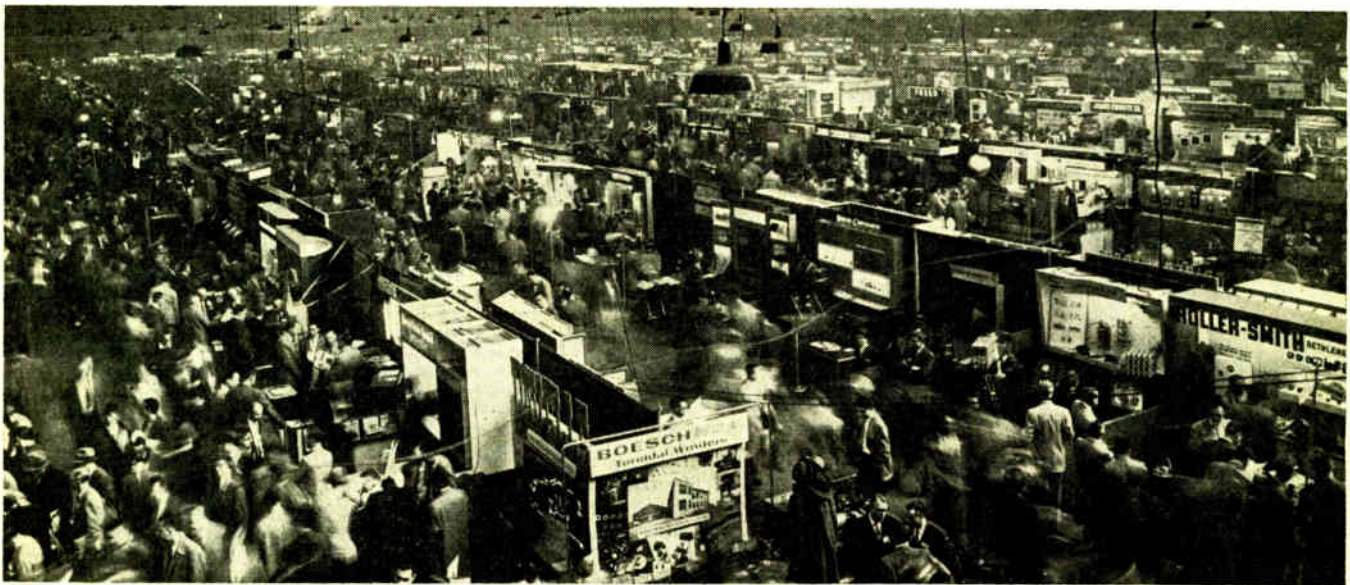

Panoramic view of the 604 electronics exhibits that covered the New York Kingsbridge Armory's four acres of floor space, March 22nd through March 25th.

1954
ANNUAL
MEETING



(Above, left to right) Dr. James W. McRae, IRE 1953 President, makes the symbolic gesture of handing over his office by presenting the gavel to incoming 1954 President William R. Hewlett.

(Left) John D. Ryder, principal speaker, addresses the 1954 Annual Meeting on "Electronic Horseless Carriages."

(Inset, right) W. R. G. Baker, IRE Treasurer and (inset, left) Haraden Pratt, IRE Secretary, give their 1954 reports at the meeting.



COLOR TV
SYMPOSIUM

(Right) Tremendous interest in the subject of color TV is shown by the packed hall at the Waldorf-Astoria Color TV Symposium at the recent IRE Convention. There were more than 100 standees during most of the three-hour session.

(Below) Speakers for this Symposium were (left to right) J. T. Mullin (Bing Crosby Enterprises); W. L. Hughes (Iowa State College); W. L. Brewer (Eastman Kodak); Harry F. Olson (RCA); Lewis Winner (Chairman, IRE Professional Group on Broadcast Transmission Systems); E. K. Jett (WMAR-TV, Session Chairman); J. H. Haines (Allen B. DuMont Labs); and J. F. Fischer (Philco).



ANNUAL CONVENTION HAS RECORD

40,108



(Above, left) IRE's President William R. Hewlett (left) presents the 1954 Medal of Honor to William L. Everitt (right) during the Annual Banquet at the Waldorf-Astoria, New York City, March 24

(Below) At the same function, Alfred N. Goldsmith (right) one of the three IRE Founders and Editor Emeritus of the Institute, receives the Founders Award from Past President James W. McRae.



New York City became the engineering capital of the world on March 22 to 25 when 40,108 members, exhibitors, and guests gathered from all parts of the world for the 1954 IRE National Convention. The attraction which caused this record-breaking attendance was the wealth of technical information presented in 243 technical papers and 604 exhibits at the Kingsbridge Armory, Waldorf-Astoria Hotel, and Hotel Shelton.

The convention opened on Monday morning, March 22, with the Annual Meeting of the Institute at which Prof. John D. Ryder, University of Illinois, gave the principal address entitled, "Electronic Horseless Carriages." The meeting also heard reports from IRE officers, including vice-president Maurice J. H. Ponte, who had travelled from France to attend the convention.

TECHNICAL SESSIONS

The 51-session program of technical papers got under way on Monday afternoon in three meeting halls at the Kingsbridge Armory, three at the Waldorf-Astoria, and one at the Shelton, and continued morning and afternoon of the following three days. The entire program was organized with the assistance of all 21 Professional Groups of the IRE, resulting in coverage of virtually

every phase of activity in the radio-electronics field, as described in detail in the March issue of PROCEEDINGS.

Highpoints of the program were two special symposia held on Tuesday evening: "Engineering Based on Biological Design" organized by the Medical Electronics Group, and "High Fidelity in Audio Engineering" sponsored by the Audio Group. Each symposium featured talks by a panel of distinguished experts followed by discussions with members of the audience.

EXHIBITS

Perhaps of greatest general interest to those attending the convention was the new exhibit site—the Kingsbridge Armory—and the exhibits themselves. The huge, four-acre drill floor of the Armory was completely filled with 604 exhibits, providing members and visitors with the unparalleled opportunity to view the latest products of a major portion of an entire industry and to speak first-hand with company representatives. Color television picture tubes, transistors, electronic computers, project Tinkertoy assemblies, ultrasonic equipment, and medical electronic apparatus were a few of the many interesting and important developments on display. The busy visitor was greatly aided

SPEAKERS' TABLE AT THE

Back Row (left to right)—Mr. Stuart L. Bailey, Vice-Chairman, 1954 IRE National Convention; Dr. John R. Pierce, Editor IRE; Mr. Haraden Pratt, Secretary IRE; Dr. Donald B. Sinclair, Senior Past President IRE; Dr. William L. Everitt, 1954 Medal of Honor winner; Dr. Alfred N. Goldsmith, Founders Award winner and Guest Speaker. Front Row in Special Awards Table. (Left) M^{rs.} Alda V. Bedford, 1954 Vladimir K. Zworykin Television Prize; (right) Dr. Harold A. Zahl, 1954 Harry Diamond Memorial Award.

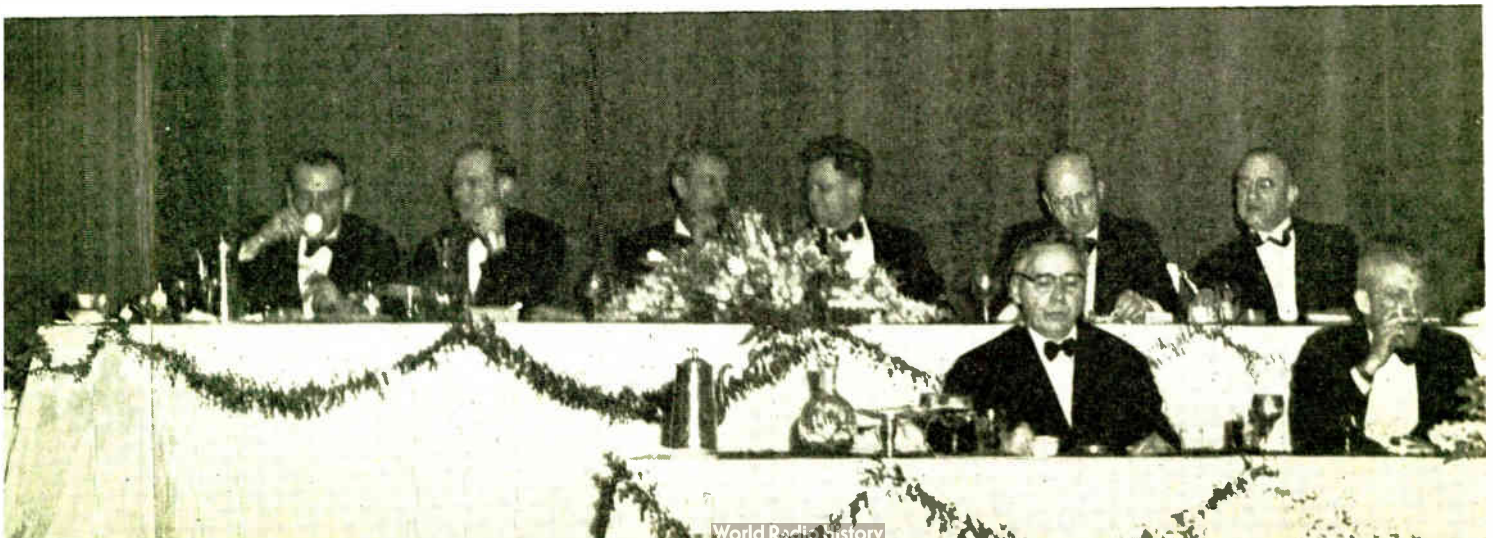

AND ENGINEERING SHOW ATTENDANCE REGISTER

by the grouping of exhibits according to general subjects and the labelling of exhibit aisles, such as, Television Avenue, Transistor Way, Radar Road, etc.

Visitors found the Kingsbridge Armory, located in the Bronx, readily accessible, both by bus and by subway, from the midtown area. Specially chartered busses provided free service between the Waldorf and the Armory at 10-minute intervals.

SOCIAL EVENTS

The social activities of the convention received a send-off on the first evening of the convention when a "get-together" cocktail party was held in the spacious Grand Ballroom of the Waldorf-Astoria, providing an excellent opportunity for visitors from all parts of the country to renew old acquaintances and make new ones.

A capacity crowd attended the IRE Annual Banquet, held in the Grand Ballroom on Wednesday evening, to hear Dr. Alfred N. Goldsmith, co-founder and Editor Emeritus of the IRE, speak on "IRE—Past and Future," the text of which appeared in the April issue of PROCEEDINGS, and to see him receive the IRE Founders Award from Past President James W. McRae for outstanding leadership in the radio engineering profes-

sion. William H. Doherty, Bell Telephone Laboratories, ably performed the duties of toastmaster.

The occasion was highlighted by the presentation of the Medal of Honor, IRE's highest technical award, to William L. Everitt, a past president of IRE and Dean of the School of Engineering at the University of Illinois. President William R. Hewlett made the presentation. Vice President M. J. H. Ponte responded on behalf of the 76 newly elected Fellows, whose photographs appear on the following pages.

Other annual awards presented by President Hewlett were: the Morris Liebmann Memorial Prize to Robert R. Warnecke, Campagne Generale de Telegraphie Sans Fil, Paris, France; the Browder J. Thompson Memorial Prize Award to R. L. Petritz, U. S. Naval Ordnance Laboratory and The Catholic University of America; the Harry Diamond Memorial Award to Harold A. Zahl, Signal Corps Engineering Laboratories; the Editor's Award to P. W. Howells, General Electric Company; and the Vladimir K. Zworykin Television Prize Award to Alda V. Bedford, Radio Corporation of America.

The social program was rounded out with a tea at IRE headquarters for wives of members attending the convention.



(Above) Dr. William M. Doherty performs the duties of Toastmaster at the recent IRE Annual Banquet.



(Above, center) Dr. Maurice J. H. Ponte, IRE Vice-President, delivers acceptance speech on behalf of the 1954 Fellow Award winners at the Banquet.



(Above) Dr. Alfred N. Goldsmith, Guest Speaker of the Banquet, and winner of the 1954 Founders Award, holds a slender volume of 124 pages containing all IRE publications for the year 1913. It made a startling comparison to today's PROCEEDINGS with no less than 128 text pages per monthly issue. The title of Dr. Goldsmith's talk was "IRE—Past and Future."

1954 IRE ANNUAL BANQUET

Back Row (left to right)—Dr. William H. Doherty, Toastmaster; Mr. William R. Hewlett, President IRE; Dr. J. W. McRae, Junior Past President IRE; Dr. Maurice J. H. Ponte, Vice-President IRE; Dr. W. R. G. Baker, Treasurer IRE; Mr. George W. Bailey, Chairman, 1954 IRE National Convention. Front Row in Special Awards Table. (Left to right) Mr. Paul W. Howells, 1954 Editor's Award; Dr. Richard L. Petritz, 1954 Browder J. Thompson Memorial Prize Award; Dr. Robert R. Warnecke, 1954 Morris Liebmann Memorial Prize Award.

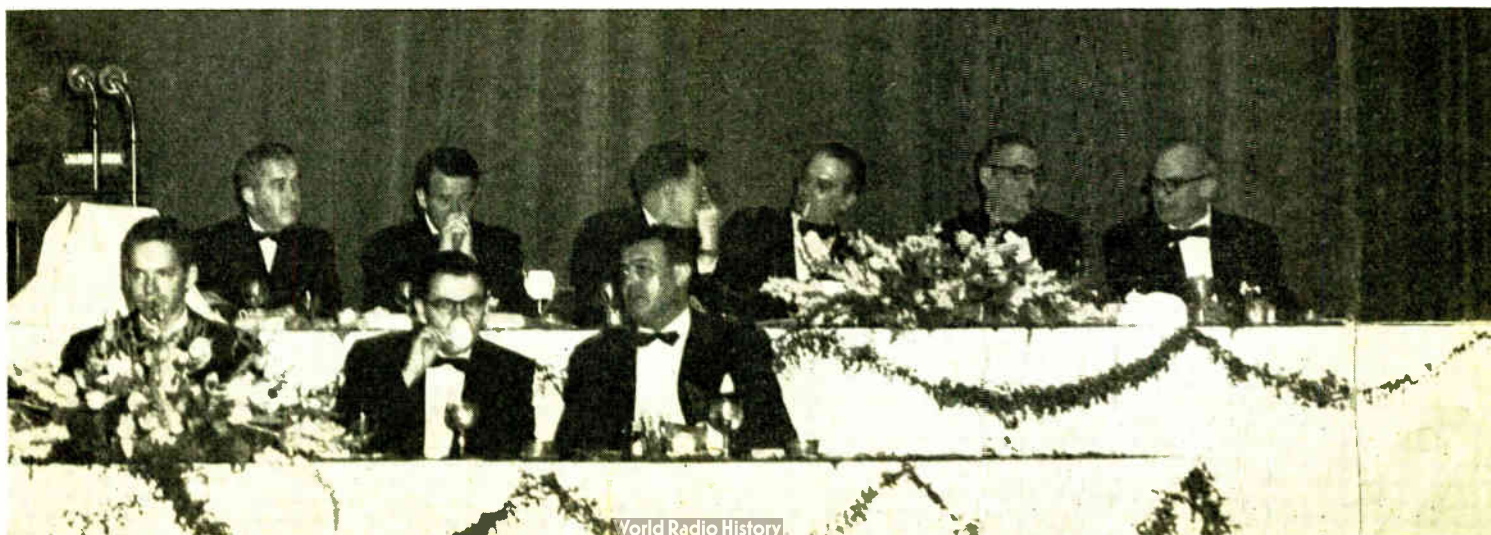

IRE Awards, 1954

Medal of Honor—1954



WILLIAM L. EVERITT

“For his distinguished career as an educator and scientist; for his contributions in establishing electronics and communications as a major branch of electrical engineering; for his unselfish contributions to the defense of our country; for his leadership in the affairs of The Institute of Radio Engineers.”

Founders Award



ALFRED N. GOLDSMITH

“For outstanding contributions to the radio engineering profession through wise and courageous leadership in the planning and administration of technical developments which have greatly increased the impact of electronics on the public welfare.”

Morris Liebmann Memorial Prize—1954



ROBERT R. WARNECKE

“For his many valuable contributions and scientific advancements in the field of electron tubes, and in particular, the magnetron class of traveling-wave tubes.”

Browder J. Thompson Memorial Prize Award—1954



R. L. PETRITZ

“For his paper entitled, ‘On the Theory of Noise in P-N Junctions and Related Devices,’ which appeared in PROCEEDINGS OF THE I.R.E.,” November, 1952.

IRE Awards, 1954

Harry Diamond Memorial Award—1954



HAROLD A. ZAHL

“For his technical contributions, his long service, and his leadership in the U. S. Army Signal Corps research program.”

Editor's Award—1954



P. W. HOWELLS

“For his paper entitled, ‘Transients in Color Television,’ which appeared in the 1953 CONVENTION RECORD OF THE I.R.E., Part 4, Session 2.”

Vladimir K. Zworykin Television Prize Award—1954



ALDA V. BEDFORD

“For his contributions to the principle of mixed highs and its application to color television.”

New Fellows



E. I. ANDERSON

"For his contributions to the improvement and simplification of radio and television circuitry."



A. V. ASTIN

"In recognition of his distinguished leadership and administration of science and engineering."



W. F. BAILEY

"For his contributions to the theory, practice, and standardization of television."



D. S. BOND

"For his contributions to the development of communication and navigation apparatus and systems."



M. R. BRIGGS

"For his contributions to the design of radio transmitters, and his leadership in the establishment of industry standards."



I. F. BYRNES

"For his contributions to development and design of equipment in the field of marine communication and navigation."



MADISON CAWEIN

"For his contributions to television theory and circuitry."

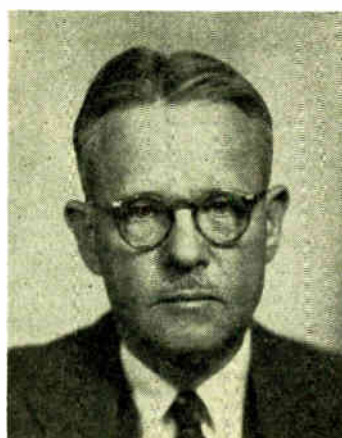

J. G. CHAFFEE

"For his contributions to transmission and relay systems and frequency modulation."



BRITTON CHANCE

"For his contributions to radar development, and to the application of electronics to biophysics."

New Fellows



MARVIN CHODOROW

"For his contributions to the theory and design of klystron tubes."



D. H. CLEWELL

"For his research in the application of instrumentation to petroleum exploration and production."

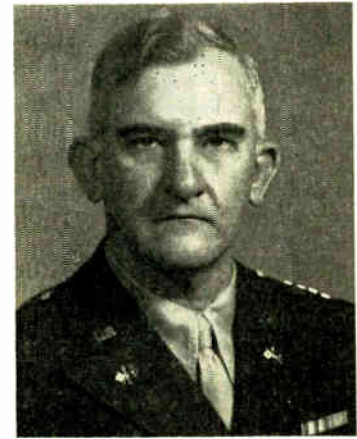

R. B. COLTON

"For his pioneering contributions to the development and application of radar in the U. S. Army."

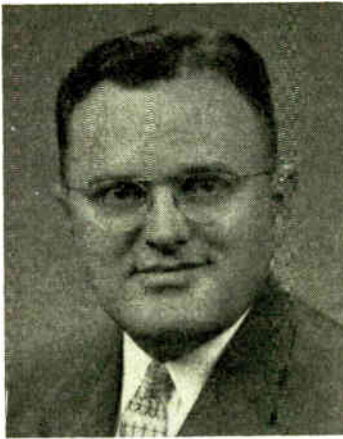

M. S. CORRINGTON

"For mathematical analysis of frequency modulation, and of transients in networks and loudspeakers."



P. M. CRAIG

"In recognition of his leadership in the design of radio and television receivers."

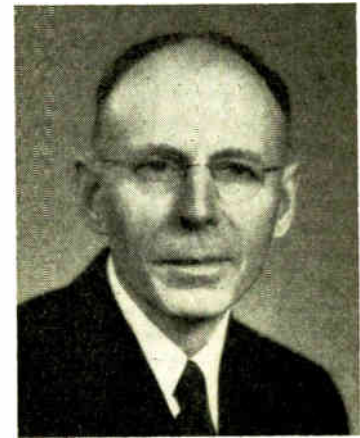

C. A. CULVER

"For his contributions to the art and literature of electronic and allied fields."



F. M. DOOLITTLE

"For his pioneering work in radio communication and radio broadcasting."



W. L. DUNN

"For his contribution in the development of radio receivers."



N. E. EDLEFSEN

"For his contribution to radar, and his leadership in the development of military electronic equipment."

New Fellows



M. A. EDWARDS

"For his creative contributions to the development of the amplidyne and other control systems."



C. L. ENGLEMAN

"For his contributions to the administration of electronic programs of the U. S. Navy."



D. C. ESPLY

"For his creative contributions to microwave and television techniques in England."



D. H. EWING

"For his contributions to the development of electronic aids to air navigation and traffic control systems."



R. M. FANO

"For his contributions in the fields of information theory and microwave filters."



E. P. FELCH

"For his contributions in the field of precision measurement and instrumentation of communication circuits."



J. L. FINCH

"For his contributions to radio communications, and particularly those associated with VLF antenna design."

R. M. FOSTER

"For basic mathematical contributions to modern network theory."



A. W. FRIEND

"For his contributions to tropospheric echo research, and to the development of magnetic materials and circuits."

New Fellows



E. G. FUBINI

"For his many contributions to the operational analysis of electronic counter measures."

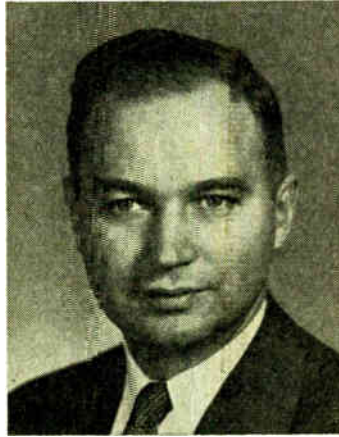

I. A. GETTING

"For his contributions to the development of automatic tracking radar systems."



J. E. GORHAM

Posthumously awarded.

"For his leadership and contributions in the field of high-power electron tubes for military applications."



C. A. GUNTHER

"For his contributions to the design and his leadership in the development of military electronic equipment."



J. P. HAGEN

"For contributions to the development of military electronic equipment, and for measurements of solar microwave radiation."



N. L. HARVEY

"For his contributions in the fields of electronic navigation and communication."



WALTER HAUSZ

"For his contributions in the fields of radar and telemetry."



J. E. HAYES

"For contributions in Canada to the development of outstanding short wave antennas and switching designs."

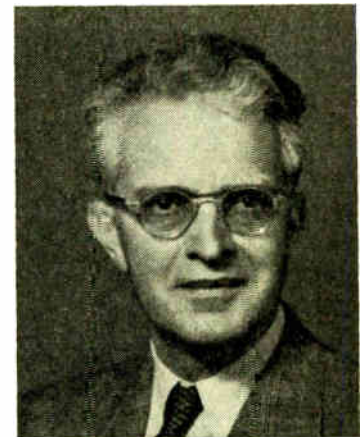

W. D. HERSHBERGER

"For his early contributions to the development of radar, and to frequency stabilization using microwave absorption lines."

New Fellows



R. D. HUNTOON

"For his contributions in the fields of electronic ordnance and electron physics."



T. G. E. HUTTER

"For his contributions in the field of electron ballistics and electron optics."



J. F. JORDAN

"For his contributions in the application of electronics to musical instruments."



W. R. KOCH

"For his creative inventions and developments in radio and television circuitry."



J. D. KRAUS

"For his leadership in antenna development, and his research contributions in radio astronomy."



J. B. H. KUPER

"For his contributions to nucleonic instrumentation and health physics."



J. M. LAFFERTY

"For his research contributions to microwave tubes and high-current density cathodes."



J. J. LAMB

"For his technical contributions to amateur radio activities, and for direction of radio and electronic circuitry development."

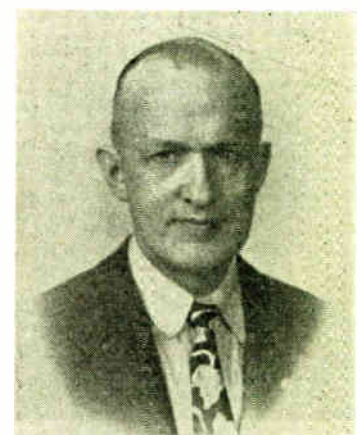

REUBEN LEE

"For his contributions to the design and development of inductive components."

New Fellows



W. D. LEWIS

"For his contributions to research, particularly in the fields of microwave filters and switching systems."



W. W. MIEHER

"For his engineering contributions and technical leadership in the development of precision radar systems."



A. W. MONTGOMERY

"For his leadership in radio and telecommunication research in England, and his services in the international liaison in these fields."



YASUJIRO NIWA

"For his leadership in radio engineering in Japan, and his contributions to vocational education."



B. M. OLIVER

"For his contributions to communications, particularly in the field of information theory and coding systems."

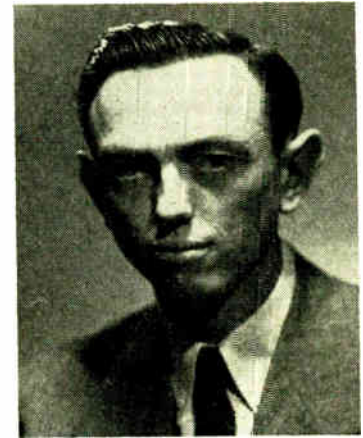

J. M. PETTIT

"For his outstanding work as engineer and educator in the field of high-frequency and microwave communications."



M. J. H. PONTE

"For his contributions to high-power electron tubes, and his unswerving leadership in electronic research in France."



DONALD A. QUARLES

"For his distinguished service in the administration of major technical programs in the fields of communications, military electronics and atomic ordnance."



W. H. RADFORD

"In recognition of his contributions through teaching and research in the field of radio communications."

New Fellows



EUGEN REISZ

"In recognition of his pioneering contribution to the development of grid-controlled electronic tubes."



HERRE RINIA

"For his creative contributions to radio engineering of Holland, and his leadership in the field of television."



T. C. RIVES

"For his leadership in military electronic research and development."



G. M. ROSE, JR.

"For his contributions to vacuum tube research, design, and manufacture, and his transistor developments."



P. C. SANDRETTO

"For his contributions to aeronautical communication and navigation."



KURT SCHLESINGER

"For many contributions to cathode-ray tubes and television circuitry."



A. H. SCHOOLEY

"For his pioneering development of fire control radar, and his contributions to electronic measurements."



H. J. SCHRADER

"For his application of information theory to navigation and television systems."



A. C. SCHROEDER

"For his contributions to television receiver circuitry, and his pioneering work in the development of color television."

New Fellows



G. R. SHAW

"For his technical contributions to the manufacture of radio tubes and their standardization."



R. F. SHEA

"For his contributions to FM receiver design, and his pioneering work in transistor applications."



SAMUEL SILVER

"For research in the field of electromagnetic radiation."



GEORGE SINCLAIR

"For his contributions to the development of radiating systems and model techniques in antenna measurements."



E. A. SPEAKMAN

"In recognition of his leadership in administration of electronic research and development."



B. R. TUPPER

"In recognition of his application of radio techniques to the extension of toll-telephone services in Canada."



W. L. WEBB

"For early contributions and engineering leadership in radio direction finding, radar, and radio communication."



P. T. WEEKS

"For his contributions to electron tube research, engineering, and manufacture."



J. O. WELDON

"For his contributions to the design of high power transmitters and their use in international broadcasting."

New Fellows



K. R. WENDT

"For his contributions to the development of television equipment and circuits."



E. M. WILLIAMS

"For his contributions to the development of military electronic equipment."



J. R. WILSON

"For his stimulating leadership in research on electron tubes and devices, and in their development and manufacture."



D. E. WOOLDRIDGE

"For his contributions to physics and electronics research, and his leadership in development efforts for national defense."



1954 Convention Record of the I.R.E.

All available papers presented at the 1954 IRE National Convention will appear in the CONVENTION RECORD OF THE I.R.E., to be published in June. The CONVENTION RECORD will be issued in eleven Parts, with each Part devoted to one general subject.

Instructions on Ordering

1. If you were a member of an IRE Professional Group and had paid the Group assessment as of April 30, 1954, you will automatically receive, free of charge, that Part of the CONVENTION RECORD pertaining to the field of interest of your Group, as indicated in the chart below.

2. If you are not a member of an IRE Professional Group, CONVENTION RECORD Parts may be purchased at the prices listed in the chart below. Orders must be accompanied by remittance, and to assure prompt delivery, should be sent immediately to The Institute of Radio Engineers, 1 East 79 Street, New York 21, N. Y.

Convention Record of the I.R.E.

PART	TITLE	FREE TO PAID MEMBERS OF FOLLOWING IRE PROFESSIONAL GROUPS	PRICES FOR MEMBERS (M) LIBRARIES (L) NON-MEMBERS (NM)		
			M	L	NM
1	Antennas & Propagation SESSIONS: 30, 37, 42, 49	Antennas & Propagation	\$1.25	\$3.00	\$3.75
2	Circuit Theory SESSIONS: 28, 35, 39, 46	Circuit Theory	1.25	3.00	3.75
3	Electronic Devices & Component Parts SESSIONS: 6, 14, 25, 32, 40, 47	Electron Devices Component Parts	1.50	3.60	4.50
4	Electronic Computers & Information Theory SESSIONS: 2, 12, 19, 27, 34	Electronic Computers Information Theory	1.50	3.60	4.50
5	Aeronautical Electronics & Telemetry SESSIONS: 3, 5, 8, 10, 15, 45	Aeronautical & Navigational Electronics Radio Telemetry & Remote Control	1.50	3.60	4.50
6	Audio & Ultrasonics SESSIONS: 11, 18, 23, 41, 48	Audio Ultrasonics Engineering	1.50	3.60	4.50
7	Broadcasting & Television SESSIONS: 13, 20, 26, 33	Broadcast Transmission Systems Broadcast & Television Receivers	1.50	3.60	4.50
8	Communications & Microwave SESSIONS: 1, 7, 21, 43, 50	Communications Systems Microwave Theory & Techniques Vehicular Communications	1.50	3.60	4.50
9	Medical & Nuclear Electronics SESSIONS: 17, 22, 24, 31	Medical Electronics Nuclear Science	1.50	3.60	4.50
10	Instrumentation & Industrial Electronics SESSIONS: 29, 36, 38, 44	Instrumentation Industrial Electronics	1.25	3.00	3.75
11	Engineering Management & Quality Control SESSIONS: 4, 9, 16	Engineering Management Quality Control	1.00	2.40	3.00
	Complete Convention Record (All Eleven Parts)		15.25	36.60	45.75



IRE News and Radio Notes

INTERNATIONAL CONVENTION TO BE HELD THIS SPRING

Fifty years ago the first paper dealing with Oxide-Coated Cathodes was published. To celebrate the anniversary, the Société Française des Ingénieurs Techniciens du Vide is organizing an International Convention to be held in Paris on the 24th and 25th of June.

The program will cover the following subjects: Basic Metal, Carbonates and Coating Process, Emission Theory of Oxide-Coated Cathodes, Definition of the Cathode Properties, Special Cathodes, and Stability of Emissive Properties.

Papers accepted by the Organizing Committee will be presented by the authors or a summary will be read by the Secretary at the sessions of the Convention. The texts will be published in a special issue of the periodical *Le Vide*, the official bulletin of the S.F.I.T.V. in their original language with, if possible, a French translation.

For further information, please write to the Société Française des Ingénieurs Techniciens du Vide, 44 rue de Rennes, Paris VI^e, France.

PAPERS FOR NUCLEAR SCIENCE CONFERENCE INVITED

The IRE Professional Group on Nuclear Science will hold its First Annual National Conference in Chicago, Ill., October 6-7 at the Sherman Hotel. The theme of the Conference will be Nuclear Reactor Technology, Particle Accelerators, and Nuclear Instrumentation. A review of European Reactor Technology by noted scientists will be presented. The first day's session will coincide with the last day of the meeting of the 1954 National Electronics Conference.

Papers are invited on the topics mentioned above, to be about 3,000 words in length. Titles and abstracts should be submitted by mail before June 1, 1954 to: T. Brill, Argonne National Laboratory, Box 299, Lemont, Ill.

Registration, program information, housing and social details will be announced in the near future.

INTERNATIONAL CONFERENCE ON SEMICONDUCTORS PLANNED

The Netherlands Physical Society, with the support of the International Union of Pure and Applied Physics and U.N.E.S.C.O., will organize an International Conference on Semiconductors, to be held at Amsterdam, Holland from June 29-July 3.

The following scientists will deliver lectures: J. Bardeen, W. H. Brattain, H. B. G. Casimir, F. A. Kröger, D. Polder, M. Schön, W. A. Shockley, R. A. Smith, H. J. Vink, and H. Welker on subjects such as bulk recombination; surface conductivity; surface trapping; surface recombination; intermetallic compounds; the band picture in polar and nonpolar semiconductors; photoconductivity in semiconductors like

PbS, PbTe, PbSe, ZnS, and CdS; and the application of general physical and chemical laws for the preparation of semiconductors with specific properties.

Discussions will be held in connection with these main lectures and there will be opportunity to discuss problems in more detail in sectional meetings. In these sectional meetings short communications of about 15 minutes each can be given.

Scientists who would like to participate in the conference or want to give a scientific contribution should communicate with the Secretary of the Society, Dr. H. J. Vink, Floralaan 142, Eindhoven, Holland, as soon as possible.

SYMPOSIUM ON INSTRUMENTATION SCHEDULED

The Institute of Industrial Health and the School of Public Health of the University of Michigan are co-sponsors of a Symposium on Instrumentation, to be held from May 24-27 at Ann Arbor, Michigan. Both manufacturers and "users" will be meeting at the University to exchange ideas and information about what is available and what is needed in the field of instrumentation for air velocity, air pollution, ionizing radiation, sound, air sampling and analysis. The Symposium is designed to be of interest to the manufacturer, safety engineer, industrial hygienist, physicist, chemist, engineer, meteorologist, and noise investigator.

Eight major speakers will give comprehensive review addresses in the eight areas in instrumentation of Industrial Hygiene. In addition, nineteen technical papers will be presented by authorities from specific fields of instrumentation. Manufacturers of instruments for industrial hygiene have been invited to exhibit and also to act as special faculty members for the Symposium.

An immediate result of the meeting will be an "encyclopedia" type of book. Papers presented at the Symposium will be published in an illustrated volume, which will also include the comprehensive review and data supplied by the manufacturers of the instruments.

Those interested in obtaining an information booklet about the Symposium should write to the following address: Director, Continued Education, 109 South Observatory Street, Ann Arbor, Michigan.

CUMULATIVE INDEX AVAILABLE

The Cumulative Index for the PROCEEDINGS OF THE I.R.E., TRANSACTIONS OF THE I.R.E. Professional Groups, and the CONVENTION RECORD OF THE I.R.E., for the period 1948-1953, will soon be available. The Index will be sold to members at a price of \$1.00, and to nonmembers at a price of \$3.00. To receive a copy of the Index, send orders with payments to The Institute of Radio Engineers, 1 East 79 Street, New York 21, N. Y.

Calendar of COMING EVENTS

- IRE National Airborne Electronic Conference, Biltmore Hotel, Dayton, Ohio, May 10-12**
- IRE-AIEE-IAS-ISA National Telemetering Conference, Morrison Hotel, Chicago, Ill., May 24-26**
- Eighth NARTB Broadcast Engineering Conference, Palmer House, Chicago, Ill., May 25-27**
- IAS Annual Summer Meeting, IAS Building, Los Angeles, Calif., June 21-24**
- IRE Symposium on Global Communications, Washington, D. C., June 23-25**
- British Institute of Radio Engineers, 1954 Convention, Christ Church, Oxford, England, July 8-12**
- Sixth Annual Oak Ridge Summer Symposium, "Modern Analytical Chemistry," Oak Ridge, Tenn., August 23-27**
- IRE-WCEMA Western Electronic Show & Convention, Pan Pacific Auditorium, Los Angeles, Calif., August 25-27**
- 1954 International Congress of Mathematicians, Royal Tropical Institute, Amsterdam, Holland, September 2-9**
- National Electronics Conference, Hotel Sherman, Chicago, Ill., October 4-6**
- Society of Motion Picture & TV Engineers Seventy-sixth Semi-Annual Convention, Ambassador Hotel, Los Angeles, Calif., October 17-22**
- IRE-RETMA Radio Fall Meeting, Hotel Syracuse, Syracuse, N. Y., October 18-20**
- IRE Quality Control Symposium, Statler Hotel, New York, N. Y., November 12-13**
- 1955 Southwestern IRE Conference and Electronics Show, Baker Hotel, Dallas, Tex., February 10-12**

PENN STATE TO OFFER SEMINARS

Pennsylvania State University, in cooperation with industry, will offer summer seminars on the following subjects: Transistors, June 9-18; Color Television, June 21-July 2; Analog Computers, June 21-July 2; Electric Contacts, June 28-July 2; and Electrostatic Precipitation, June 21-25.

The courses are primarily designed to disseminate information on the recent technological advances in these various fields. Newcomers in these fields, as well as experienced men, will benefit by the seminars.

Further information may be obtained by writing R. L. Riddle, Chairman, Short Course Committee, Pennsylvania State College, State College, Pa.

IRE News and Radio Notes

TECHNICAL COMMITTEE NOTES

The **Feedback Control Systems** Committee convened on February 5th under the chairmanship of J. E. Ward. Chairman Ward introduced the following guests who have been invited to become members: Professor D. P. Lindorff, University of Connecticut; D. L. Lippitt, General Electric Co.; and T. K. Maples, Doelcam Corp. Chairman Ward discussed the use of such names as decilog (dg) and logit (lg) for this logarithmic ratio, but the Committee did not reach a definite conclusion. The Committee discussed the new phrasing of the Scope of Activities for Committee 26 as suggested by L. G. Cumming, Technical Secretary. The Committee recommended accepting the wording as is, with the deletion of the second paragraph. Chairman Ward reported to the Committee on his conversation with J. C. Lozier regarding the action taken by Subcommittee 26.1 at their last meeting. The Subcommittee after further discussion could not agree that a summing point should be used in the Basic Feedback Control Loop, since some of the members of the subcommittee still preferred the use of the more general mixing point. For the benefit of the guests of the Committee, some of the discussions regarding the choice of a summing point in the Basic Feedback Control Loop were reviewed. There was a discussion of Measurements (Methods of Testing) and Standards of Performance for Feedback Control Systems. A list of terms was compiled which are in common use for Feedback Control Systems. The list pertained to Measurements and Standards of Performance. These terms were grouped and assigned to members of the Committee to investigate existing definitions and suggested definitions thereby eliminating duplication of effort.

Under the chairmanship of P. C. Sandretto the **Navigation Aids** Committee convened on February 9th. Final consideration was given to the list of Navigation terms submitted by Mr. Gray. General Sandretto notified the members of his resignation as Chairman of the Navigation Aids Committee and announced that Professor Mimno would be the new Chairman for the coming year. He expressed his thanks to the Committee members for their co-operation and for the excellent work performed by them during his tenure as Chairman.

On February 18th the **Radio Transmitters** Committee met under the chairmanship of P. J. Herbst. The scope of Committee 15 as revised at the February 11 meeting of the Standards Committee was read to the group. The committee discussed the unsatisfactory aspects of the revised scope. It was decided by the committee to write a letter to Chairman Jensen of the Standards Committee, suggesting the formation of an ad hoc committee to study the problem of either assigning systems work to existing committees, or creating new committees to handle certain systems aspects. There was a report of the Ad Hoc Committee on Spurious Responses. Suggestions were made by the main committee. The report will be referred to the Ad Hoc Committee with the request that they continue to clarify the Report. A vote of confidence was given to the committee members for their work. There was a review of the Proposed Standard on Television Transmitters. A number of suggestions were made and this standard will be referred to the subcommittee. The proposed Standard on Pulses: Methods of Measurement of Pulse Quantities with changes incorporated according to suggestions received from the Grand Tour, was referred to the Standards Committee for review and possible approval, at its April meeting. The Committee

thanked Chairman H. Goldberg and members of the Subcommittee 15.4 for their work on this Standard. Chairman Herbst read a report from Mr. Brown, Chairman of Subcommittee 15.5. It stated that their work on definitions has in general been completed and a list of tentative definitions agreed upon. Work is well under way on methods of measurement of the various characteristics of single sideband transmitters. A tentative standard should be completed within the next four months.

On February 17th the **Video Techniques** Committee convened under the chairmanship of W. J. Poch. A letter from the West Coast representative, Cameron Pierce, was read in which the names of R. DeBaun and E. Benham were suggested for the Committee roster. Approval for these additions to the membership was unanimous. E. Weppeler agreed to become Chairman of a new Definitions subcommittee, thereby satisfying a long-felt need in the Video Techniques Committee. J. L. Jones reported that his subcommittee was making good progress toward the preparation of the proposed standard on the Methods of Measurement of Differential Gain and Differential Phase. It is hoped that the material will be ready for submission to the Committee within several months. J. R. Hefele reported in Mr. Baracket's absence that the Subcommittee on Video Systems and Components had not met since November but that several projects were being actively pursued by the membership. Dr. Athey reported on the general status of the work in the video recording field. A list of television signal measurement terms circulated to the Committee membership was reviewed at some length. Some corrections were made and final approval was given. It was agreed that these definitions should be given to the Definitions Co-ordinator.

Professional Groups

	Chairman		Chairman
AERONAUTICAL AND NAVIGATIONAL ELECTRONICS	K. C. Black Polytechnics Res. and Devel. Co. Brooklyn, N. Y.	INDUSTRIAL ELECTRONICS	Eugene Mittelmann 549 W. Washington Blvd., Chicago, Ill
ANTENNAS AND PROPAGATION	P. S. Carter RCA Labs. Rocky Point, L. I., N. Y.	INFORMATION THEORY	Dr. William G. Tuller Melpar, Inc., 452 Swann Ave. Alexandria, Va.
AUDIO	Vincent Salmon Stanford Research Institute Stanford, Calif.	INSTRUMENTATION	I. G. Easton General Radio Co. Cambridge, Mass.
BROADCAST AND TELEVISION RECEIVERS	Earl I. Anderson RCA Labs. Div. 711-5-Ave., New York, N. Y.	MEDICAL ELECTRONICS	L. H. Montgomery, Jr. Vanderbilt U., Nashville, Tenn.
BROADCAST TRANSMISSION SYSTEMS	Lewis Winner 52 Vanderbilt Ave., New York, N. Y.	MICROWAVE THEORY AND TECHNIQUES	Andre G. Clavier Federal Telecomm. Labs., Inc. Nutley, N. J.
CIRCUIT THEORY	C. H. Page National Bureau of Standards Washington, D. C.	NUCLEAR SCIENCE	L. V. Berkner 350 5th Ave. New York, N. Y.
COMMUNICATIONS SYSTEMS	Col. John Hessel Signal Corps Eng. Labs. Fort Monmouth, N. J.	QUALITY CONTROL	Leon Bass General Elec. Co. Cincinnati, Ohio
COMPONENT PARTS	Floyd A. Paul Northrop Aircraft, Inc. Hawthorne, Calif.	RADIO TELEMETRY AND REMOTE CONTROL	M. V. Kiebert, Jr. P. R. Mallory & Co., Inc. Indianapolis, Ind.
ELECTRONIC DEVICES	L. S. Nergaard RCA Labs., Princeton 5, N. J.	ULTRASONICS ENGINEERING	A. L. Lane Naval Ordnance Labs. White Oak, Md.
ELECTRONIC COMPUTERS	John H. Howard Burroughs Adding Machine Co. Philadelphia, Pa.	VEHICULAR COMMUNICATIONS	W. A. Shipman Columbia Gas. Sys. Ser. Corp. 120 E. 41 St., N. Y. 17, N. Y.
ENGINEERING MANAGEMENT	Gen. T. C. Rives General Electric Co., Syracuse, N. Y.		

Sections*

Chairman

R. M. Byrne
316 Melbourne Ave.
Akron, Ohio

L. E. French
107 Washington St. SE
Albuquerque, N. M.

G. M. Howard
413 Ridgecrest Rd., N.E.
Atlanta, Ga.

G. R. White
Bendix Radio Div.
Towson 4, Md.

L. C. Stockard
1390 Lucas Drive
Beaumont, Texas

N. S. Lawrence
Johnson's Corners, R.D. 1
Harpursville, N. Y.

Beverly Dudley
Technology Review
Mass. Inst. Technology
Cambridge, Mass.

Luis M. Malvarez
Commandant Franco 390
Olivos—FCGBM
Buenos Aires, Arg.

R. R. Thalner
254 Rano St.
Buffalo, N. Y.

J. W. Smith
1136-27 St., N.E.
Cedar Rapids, Iowa

H. R. Denius
Box Q
Melbourne, Fla.

A. A. Gerlach
4020 Overhill Ave.
Chicago 34, Ill.

W. B. Shirk
6342 Hamilton Ave.
Cincinnati 24, Ohio

S. J. Begun
3405 Perkins Ave.
Cleveland 14, Ohio

C. B. Sloan
568 Arden Rd.
Columbus 2, Ohio

Eric Vaughan
657 Stafford Ave.
Bristol, Conn.

J. K. Godbey
Magnolia Petroleum Co.
Field Research Lab.
Box 900
Dallas, Tex.

A. H. Petit
444 E. Peach Orchard Ave.
Dayton, Ohio

E. H. Forsman
3609 East 34 Ave.
Denver, Colo.

W. L. Cassell
Iowa State College
Ames, Iowa

E. J. Love
9264 Boleyn
Detroit 24, Mich.

Secretary

AKRON (4) H. L. Flowers
2029-19 St.
Cuyahoga Falls, Ohio

ALBUQUERQUE-
LOS ALAMOS (7) R. K. Moore
2808 Mesa Linda Dr. NE
Albuquerque, N. M.

ATLANTA (6) K. Winston Bugg
Board of Education
14 Fl., City Hall
Atlanta, Ga.

BALTIMORE (3) C. F. Miller
Johns Hopkins Univ.
105 Md. Hall
Baltimore, Md.

BEAUMONT-
PORT ARTHUR (6) John Petkovsek, Jr.
4390 El Paso Ave.
Beaumont, Texas

BINGHAMTON (4) Edward Klinko
27 Linden St.
Binghamton, N. Y.

BOSTON (1) H. A. Dorschug
Radio Station WEEI
182 Tremont St.
Boston 12, Mass.

BUENOS AIRES Alejandro Rojo
Transradio Internacional
San Martin 379
Buenos Aires, Arg.

BUFFALO-
NIAGARA (4) D. P. Welch
859 Highland Ave.
Buffalo 23, N. Y.

CEDAR RAPIDS
(5) R. M. Ringoen
1941 Washington Ave., SE
Cedar Rapids, Iowa

CENTRAL
FLORIDA (6) K. A. West
1345 Indian River Dr.
Eau Gallie, Fla.

CHICAGO (5) W. E. Berkey
Westinghouse Electric
Merchandise Mart Plaza
Chicago 54, Ill.

CINCINNATI (5) W. W. Gulden
3272 Daytona Ave.
Cincinnati 11, Ohio

CLEVELAND (4) W. A. Howard
National Broadcasting Co.
815 Superior Ave.
Cleveland, Ohio

COLUMBUS (4) P. I. Pressel
599 Northridge Rd.
Columbus 14, Ohio

CONNECTICUT
VALLEY (1) P. F. Ordnung
Dunham Lab., Yale Univ.
New Haven, Conn.

DALLAS-FORT
WORTH (6) M. W. Bullock
6805 Northwood Rd.
Dallas, Tex.

DAYTON (5) M. A. McLennan
304 Schenck Ave.
Dayton, Ohio

DENVER (5) Sidney Bedford, Jr.
Mountain States Tel. &
Tel.
Room 802
Denver, Colo.

DES MOINES-
AMES (5) R. E. Price
1706 Franklin Ave.
Des Moines, Iowa

DETROIT (4) M. B. Scherba
270 S. Melborn
Dearborn, Mich.

Chairman

H. F. Dart
923 Farnham St.
Elmira, N. Y.

Lt. Col. W. B. Sell
A.F.F. Bd. No. 4
Fort Bliss, Tex.

J. B. Grund
Sylvania Electric Prod-
ucts Inc.
Emporium, Pa.

B. H. Baldrige
R.R. 12 Kratzville Rd.
Evansville, Ind.

L. F. Mayle
The Magnavox Co.
Fort Wayne, Ind.

John Lucyk
77 Park Row S.
Hamilton, Ont., Canada

I. G. Mercer
Box 1380 KHON
Honolulu, T. H.

K. O. Heintz
202 Humble Blvd.
Houston, Tex.

J. R. Haeger
1107 Times Bldg.
Huntsville, Ala.

H. R. Wolff
5135 E. North St.
Indianapolis, Ind.

F. S. Howell
313-B Tyler St.
China Lake, Calif.

C. R. Burrows
116 Mitchell St.
Ithaca, N. Y.

J. H. Van Horn
Telecom., Inc.
1019 Admiral Blvd.
Kansas City, Mo.

W. F. Stewart
1219 Skyline Dr.
N. Little Rock, Ark.

G. A. Robitaille
19 McKinnon Pl.
London, Ont., Canada

Vincent Learned
2 Prescott St.
Garden City, L. I., N. Y.

E. F. King
3171 Federal Ave.
Los Angeles 34, Calif.

M. I. Schwalbe
Veterans Admin. Hosp.
Louisville 2, Ky.

A. H. Lynch
Box 466
Ft. Myers, Fla.

H. J. Zwarra
722 N. Bdwy., Rm. 1103
Milwaukee, Wis.

D. A. Anderson
159 Sunnyside Ave., Lake-
side
Montreal 33, Que.

G. W. Wood
Tulane University
Physics Department
New Orleans 18, La.

S. S. Shamis
11 Stanley Rd.
West Orange, N. J.

Secretary

ELMIRA-CORNING
(4) E. M. Guyer
Corning Glass Works
Corning, N. Y.

EL PASO (7) Harold Hopp
2404 Copper St.
El Paso, Tex.

EMPORIUM (4) D. A. Dander
101 W. Fourth St.
Emporium, Pa.

EVANSVILLE-
OWENSBORO (5) E. C. Gregory
1120 S.E. First St.
Evansville, Ind.

FORT WAYNE (5) Clifford Hardwick
2905 Chestnut St.
Fort Wayne, Ind.

HAMILTON (8) A. L. Fromanger
79 Park Row Ave. N
Hamilton, Ont., Canada

HAWAII (7) M. S. Vittum
Box 43
Honolulu, T. H.

HOUSTON (6) E. W. Helken
Trans Tex. Airways
Municipal Airport
Houston, Tex.

HUNTSVILLE (6) C. O. Brock
220 W. Rhett Ave.
Huntsville, Ala.

INDIANAPOLIS (5) M. J. Arvin
4329 Fletcher Ave.
Indianapolis, Ind.

INYOKERN (7) H. A. Kirsch
528 K. Nimitz
China Lake, Calif.

ITHACA (4) Benjamin Nichols
Franklin Hall, Cornell U.
Ithaca, N. Y.

KANSAS CITY (5) Mrs. G. L. Curtis
Radio Industries, Inc.
1307 Central Ave.
Kansas City, Kan.

LITTLE ROCK (5) J. E. Wylie
2701 N. Pierce
Little Rock, Ark.

LONDON
(CANADA) (8) J. D. B. Moore
27 McClary Ave.
London, Ont., Canada

LONG ISLAND
(2) J. F. Bisby
160 Old Country Rd.
Mineola, L. I., N. Y.

LOS ANGELES (7) W. E. Peterson
4016 Via Cardelina, Palos
Verdes Estates, Calif.

LOUISVILLE (5) G. W. Yunk
2236 Kaelin Ave.
Louisville 2, Ky.

MIAMI (6) P. J. Sammon
3340 S.W. 26 St.
Miami, Fla.

MILWAUKEE (5) Alex Paalu
1334 N. 29 St.
Milwaukee, Wis.

MONTREAL (8) Sydney Bonneville
Beaver Hall Hill
Montreal, P. Q., Canada

NEW ORLEANS
(6) J. A. Cronvich
Box 39, Rural Route 7
New Orleans 23, La.

NEW YORK (2) A. C. Beck
Box 107
Red Bank, N. J.

* Numerals in parenthesis following Section designate Region number.

Sections

Chairman

G. B. Hoadley
North Carolina State Col-
lege Raleigh, N. C.

C. W. Mueller
Box 1082, c/o CAA
Oklahoma City, Okla.

M. L. McGowan
5544 Mason St.
Omaha 6, Neb.

J. A. Loutit
674 Melbourne Ave.
Ottawa 3, Ont., Canada

J. G. Brainerd
Moore School, U. of Penn
Philadelphia 4, Pa.

A. M. Creighton, Jr.
2201 E. Osborn Rd.
Phoenix, Ariz.

J. H. Greenwood
530 Carleton Ho. WCAE
Pittsburgh, Pa.

G. C. Ellison, Jr.
11310 S.E. Market St.
Portland, Ore.

J. S. Donal, Jr.
RCA Labs.
Princeton, N. J.

Allan Holstrom
551 Spencer Rd.
Rochester, N. Y.

J. H. Vogelmann
404 W. Cedar St.
Rome, N. Y.

H. C. Salter
1945 Bidwell Way
Sacramento, Calif.

E. F. O'Hare
8325 Delcrest Dr.
University City 24, Mo.

Clayton Clark
710 N. First East St.
Logan, Utah

John Ohman
207 Windsor
San Antonio, Tex.

W. S. Ivans, Jr.
8669 Lemon Ave.
La Mesa, Calif.

J. R. Whinnery
U. of Cal. EE. Dept.
Berkeley, Calif.

R. B. Russ
Union College
Schenectady, N. Y.

H. M. Swarm
University of Washington
Seattle, Wash.

Richard F. Shea
225 Twin Hills Drive
Syracuse, N. Y.

R. G. Larson
2647 Scottswood Ave.
Toledo, Ohio

J. R. Bain
169 Kipling Ave. S.
P. O. 54
Toronto, Ont., Canada

C. E. Day
Geophysical Research
Corp.
2607 N. Boston Pl.
Tulsa, Okla.

Secretary

M. J. Minor
Rt. 3, York Rd.
Charlotte, N. C.

W. E. Lucey
1348 Kinkaid Dr.
Oklahoma City, Okla.

C. W. Rook
Univ. of Nebraska
Lincoln 8, Neb.

D. V. Carroll
Box 527
Ottawa, Ont., Canada

C. R. Kraus
1835 Arch St.
Philadelphia 3, Pa.

W. R. Saxon
Neely Enterprises
32 W. Jefferson St.
Phoenix, Ariz.

K. A. Taylor
Bell Tele. Co. of Pa.
416 Seventh Ave.
Pittsburgh, Pa.

R. W. Schmidt
1235 S.W. Freeman St.
Portland, Ore.

G. S. Sziklai
Box 3
Princeton, N. J.

W. F. Bellor
186 Dorsey Rd.
Rochester, N. Y.

Fred Moskowitz
1014 N. Madison St.
Rome, N. Y.

R. C. Bennett
2239 Marconi Ave.
Sacramento, Calif.

F. A. Fillmore
5758 Itaska St.
St. Louis, Mo.

J. S. Hooper
1936 Hubbard Ave.
Salt Lake City 5, Utah

Paul Tarrodaychik
215 Christine Dr.
San Antonio, Tex.

Harold Story
1068 Agate St.
San Diego 9, Calif.

A. J. Morris
812-11 Ave.
Redwood City, Calif.

L. T. Bowles, Jr.
33 Fredericks Road
Scotia 2, N. Y.

K. R. Willson
1100-17th Ave.
Seattle 22, Wash.

Major A. Johnson
162 Lincoln Ave.
Syracuse, N. Y.

R. E. Weeber
3141 Westchester
Toledo, Ohio

E. L. Palin
2139 Bayview Ave.
Toronto, Ont., Canada

C. S. Dunn
1926 S. Knoxville
Tulsa, Okla.

Chairman

O. W. Muckenhirn
EE Dept., U. of Minn.
Minneapolis, Minn.

D. D. Carpenter
1689 W. 29 Ave.
Vancouver, B. C., Canada

H. P. Meisinger
Hull & Old Courthouse
Rds.
Rt. 3, Vienna, Va.

R. C. Lepley
R.D. 2
Williamsport, Pa.

John Greenaway
403 Tinniswood St.
Winnipeg, Canada

TWIN CITIES (5)

VANCOUVER (8)

WASHINGTON (3)

WILLIAMSPORT
(4)

WINNIPEG (8)

Secretary

N. B. Coil
1664 Thomas Ave.
Saint Paul 4, Minn.

J. E. Breeze
5591 Toronto Rd.
Vancouver, B. C., Canada

H. I. Metz
Dept. of Commerce, CAA
Room 2094, T-4 Bldg.
Washington, D. C.

W. H. Bresee
818 Park Ave.
Williamsport, Pa.

R. M. Simister
179 Renfrew St.
Winnipeg, Canada

Subsections

Chairman

R. F. Lee
2704-31 St.
Lubbock, Tex.

James Galbraith
126 W. Main St.
North Adams, Mass.

W. A. Bowen, Jr.
225 E. Guava St.
Oxnard, Calif.

R. V. Higdon
1030 S. Atherton St.
State College, Pa.

F. G. McCoy
Rt. 4, Box 452-J
Charleston, S. C.

W. W. Salisbury
910 Mountain View Dr.
Lafayette, Calif.

Allen Davidson
3422 Argyle Ave.
Erie, Pa.

G. F. Brett
326 E. Orange St.
Lancaster, Pa.

D. M. Saling
2 Baker St.
Poughkeepsie, N. Y.

O. D. Perkins
Signal Corps Eng. Labs.
Fort Monmouth, N. J.

G. P. McCouch
Aircraft Radio Corp.
Boonton, N. J.

W. M. Kidwell
1516 Oaurel Ave.
Pomona, Calif.

H. M. Stearns
990 Varian St.
San Carlos, Calif.

W. V. Record
4511 E. Ninth St.
Tucson, Ariz.

Capt. L. A. Yarbrough
3001 USAFIT
Wright-Patterson
Air Force Base, Ohio

H. H. Newby
1428 Woodrow
Wichita, Kan.

Secretary

C. M. McKinney
3102 Oakmont
Austin, Tex.

John Schimmel
150 Main St.
Williamstown, Mass.

E. C. Sternke
Route 2, Box 122
Camarillo, Calif.

W. L. Baker
1184 Oneida St.
State College, Pa.

C. B. Lax
Sergeant Jasper Apts.
Charleston, S. C.

J. M. Rosenberg
1134 Norwood Ave.
Oakland 10, Calif.

K. L. Hestor
2909 Tuttle Ave.
Erie, Pa.

M. B. Lemeshka
RCA, New Holland Ave.
Lancaster, Pa.

E. A. Keller
Red Oaks Mill Rd.
R.D. 2
Poughkeepsie, N. Y.

Edward Massell
Box 433
Locust, N. J.

W. R. Thurston
923 Warren Parkway
Teaneck, N. J.

Eli Blutman
6814 Glacier Dr.
Riverside, Calif.

W. W. Harman
Elec. Research Lab.
Stanford U.
Stanford, Calif.

A. J. Bersbach
5326 E. Seventh St.
Tucson, Ariz.

Lt. Col. R. D. Sather
Box 3344 USAFIT
Wright-Patterson Air
Force Base, Ohio

H. O. Byers
333 Laura Ave.
Wichita, Kan.

Abstracts and References

Compiled by the Radio Research Organization of the Department of Scientific and Industrial Research, London, England, and Published by Arrangement with that Department and the *Wireless Engineer*, London, England

NOTE: The Institute of Radio Engineers does not have available copies of the publications mentioned in these pages, nor does it have reprints of the articles abstracted. Correspondence regarding these articles and requests for their procurement should be addressed to the individual publications, not to the I.R.E.

Acoustics and Audio Frequencies.....	884
Antennas and Transmission Lines.....	886
Automatic Computers.....	886
Circuits and Circuit Elements.....	887
General Physics.....	888
Geophysical and Extraterrestrial Phenomena.....	889
Location and Aids to Navigation.....	890
Materials and Subsidiary Techniques...	890
Mathematics.....	893
Other Applications of Radio and Electronics.....	894
Propagation of Waves.....	894
Reception.....	894
Stations and Communication Systems..	894
Subsidiary Apparatus.....	895
Television and Phototelegraphy.....	895
Transmission.....	897
Tubes and Thermionics.....	897
Miscellaneous.....	898

The number in heavy type at the upper left of each Abstract is its Universal Decimal Classification number and is not to be confused with the Decimal Classification used by the United States National Bureau of Standards. The number in heavy type at the top right is the serial number of the Abstract. DC numbers marked with a dagger (†) must be regarded as provisional.

A new section has been introduced covering the general technique of electromagnetic waves, oscillations and pulses (i.e. transmission lines and circuits), as distinct from specific applications to telecommunications. The new section is numbered 621.37, with subdivisions. Full details of the new classification, and of the numbers which become obsolete as a result of its introduction, are given in PE Note 535, obtainable from The International Federation for Documentation, Willem Witsenplein 6, The Hague, Netherlands, or from The British Standards Institution, 2 Park Street, London, W.1., England.

Section 621.396.67, dealing with Antennas, has been modified and expanded; details of the new classifications are given in PE Note 519.

Section 621.396.96, with subdivisions, has been introduced to cover Radar; details of the new classifications are given in PE Note 518.

New Subject Section

A section headed Automatic Computers has been introduced.

ACOUSTICS AND AUDIO FREQUENCIES

534:061.3	919
International Congress on Acoustics, Delft (Netherlands), 15th-25th June 1953—P. Chavasse and R. Lehmann. (<i>Ann. Télécommun.</i> , vol. 8, pp. 335-338; Oct., 1953.) A brief report of the proceedings, with titles of the papers presented. See also 2855 of 1953.	
534.1.001.362	920
Transformer Couplings for Equivalent-Network Synthesis—B. B. Bauer. (<i>Jour. Acous. Soc. Amer.</i> , vol. 25, pp. 837-840; Sept., 1953.) Equivalent circuits for mechanical arrays, based on the impedance analogy, are obtained in a simple way by introducing ideal transformer couplings.	
534.121.2	921
On the Vibration of Mass-Loaded Mem-	

The Index to the Abstracts and References published in the PROC. I.R.E. from February 1953 through January 1954 is published by *Wireless Engineer* and included in the March 1954 issue of that journal. Copies of this issue may be purchased for \$1 (including postage) from the Institute of Radio Engineers, 1 East 79th Street, New York 21, N.Y. As supplies are limited, the publishers ask us to stress the need for early application for copies. Included with the Index is a selected list of journals canned for abstracting with publishers' addresses.

branes—E. T. Kornhauser and D. Mintzer. (*Jour. Acous. Soc. Amer.*, vol. 25, pp. 903-906; Sept., 1953.) The conventional treatment originated by Rayleigh is discussed, and some of the results are shown to be invalidated by an unfounded assumption.

534.13:534.414 922

Theory of the Free Vibrations of Isotropic Elastic Media—E. Ledinegg and P. Urban. (*Acta Phys. Austriaca*, vol. 7, pp. 420-435; Sept., 1953.) First-order perturbation theory is used to calculate the natural frequencies of an inhomogeneous system of arbitrary form. The method is used to determine the variation of the natural frequency of a system when its elastic constants are subjected to small spatially distributed variations. Calculations are made of the variation of resonance frequency of a cylindrical acoustic resonator on introduction of (a) an axial rod, and (b) a transverse plate. Application to the determination of Lamé's constants is discussed.

534.13:621.395.61/.62 923

The Coupling of Mechanical and Acoustic Vibration Systems—W. Güttner. (*Acustica*, vol. 3, pp. 201-206; 1953. In German.) A wide-band transducer is obtained by coupling a Helmholtz resonator to the mechanical system. The optimum bandwidth conditions are attained when the reception, or the radiation, does not involve the resonator. As an example, the frequency response of a crystal microphone is determined.

534.141.4 924

On Edge Tones and Associated Phenomena—A. Powell. (*Acustica*, vol. 3, pp. 233-243; 1953. In English.) Edge-tone phenomena occurring at high jet speeds have been photographed and analyzed.

534.2 925

The Concept of Radiation Scattering and Its Application to Reinforced Cylindrical Shells—M. C. Junger. (*Jour. Acoust. Soc. Amer.*, vol. 25, pp. 899-903; Sept., 1953.) A method of analysis is developed permitting investigation of complex structures which cannot be treated by the methods previously described (3299 of 1952). The radiation pressure is expressed as the sum of two terms, one corresponding to the contribution from a rigid scatterer and the other to the contribution due to the vibration of the actual scatterer in response to the incident wave. Special cases are examined.

534.2 926

Acoustic Streaming at Low Reynolds Numbers—J. M. Andres and U. Ingard. (*Jour. Acoust. Soc. Amer.*, vol. 25, pp. 932-938; Sept., 1953.)

534.2 927

Acoustic Streaming at High Reynolds Num-

bers—J. M. Andres and U. Ingard. (*Jour. Acoust. Soc. Amer.*, vol. 25, pp. 928-932; Sept., 1953.)

534.2 928

Acoustic Streaming Equations: Laws of Rotational Motion for Fluid Elements—W. L. Nyborg. (*Jour. Acoust. Soc. Amer.*, vol. 25, pp. 938-944; Sept., 1953.)

534.2 929

The Propagation of Sound in a Medium with Random Fluctuations of the Refractive Index—V. Ya. Kharanen. (*Compt. Rend. Sci. U.S.S.R.*, vol. 88, pp. 253-256; Jan. 11, 1953. In Russian.) The effect of small fluctuations in a medium whose refractive index is nearly unity is considered theoretically. An expression for the deflection of the sound wave is derived. The results of the particular cases considered can be applied to the problem of the propagation of sound in the surface layer of the sea. See also 847 of 1947 (Bergmann).

534.2-13 930

The Attenuation of Sound Propagated over the Ground—J. D. Hayhurst. (*Acustica*, vol. 3, pp. 227-232; 1953.) The effect of wind on sound propagation over a concrete runway was investigated experimentally for distances up to 800 m. The only significant parameter is the component of wind along the direction of propagation, but the attenuations are statistically independent of the absolute wind speed. The change of attenuation with frequency and with height above ground is shown graphically.

534.2-14 931

Wave Propagation in a Randomly Inhomogeneous Medium: Part 1—D. Mintzer. (*Jour. Acous. Soc. Amer.*, vol. 25, pp. 922-927; Sept., 1953.) "The propagation of sound pulses from a point source in a medium where the index of refraction varies randomly is studied by means of a Born approximation to the wave equation. The coefficient of variation (standard deviation of the amplitude of a series of pulses, expressed as a percentage of the mean amplitude of the series) is evaluated for pulse lengths short compared with the time in which the refractive index varies significantly, and for ranges large compared with the wavelength of the sound. The results are in agreement with the experiments of Sheehy [1055 of 1950]."

534.21-16 932

Magnetic Damping of Acoustic Waves in Conducting Media—E. T. Kornhauser. (*Jour. Acous. Soc. Amer.*, vol. 25, pp. 1011-1012; Sept., 1953.) An elementary analysis is presented and the results are compared with those of Anderson (2635 of 1953).

534.213-14 933

The Acoustic Properties of Gas-Bubble

- Screens in Water—E. Meyer and E. Skudrzyk. (*Akust. Beihefte*, no. 3, pp. 434–440; 1953.)
- 534.213.4–14:534.64 934
Acoustic Impedance of Rectangular Tubes—J. K. Wood and G. B. Thurston. (*Jour. Acous. Soc. Amer.*, vol. 25, pp. 858–860; Sept., 1953.) Theoretically derived values of the impedance of a section of a system of infinite parallel planes are in good agreement with measured values for long narrow tubes, when the latter are corrected for end effects.
- 534.213.4–14:534.64 935
End Corrections for a Concentric Circular Orifice in a Circular Tube—G. B. Thurston and J. K. Wood. (*Jour. Acous. Soc. Amer.*, vol. 25, pp. 861–863; Sept., 1953.) The values of the end correction found experimentally for the acoustic impedance of a tube with an orifice are in good agreement with values derived theoretically, treating the orifice as a plane-piston source.
- 534.23 936
Optimum Directivity Patterns for Linear Point Arrays—R. L. Pritchard. (*Jour. Acous. Soc. Amer.*, vol. 25, pp. 879–891; Sept., 1953.) Extended version of 3292 of 1948 (Pritchard and Rosenberg).
- 534.23 937
Approximate Calculation of the Directivity Factor of Linear Point Arrays—R. L. Pritchard. (*Jour. Acous. Soc. Amer.*, vol. 25, pp. 1010–1011; Sept., 1953.)
- 534.232:546.431.824–31 938
Barium Titanate Admittance-Temperature Characteristics—A. L. Lane. (*Jour. Acous. Soc. Amer.*, vol. 25, pp. 873–878; Sept., 1953.) Admittance variations over the temperature range 34 degrees to 67 degrees F. are studied for underwater transducers made of BaTiO₃ with and without addition of lead as a temperature stabilizer. Though the dielectric and piezoelectric constants of the material vary widely over this temperature range, it is possible for the transducer admittance to vary very little at certain frequencies near resonance.
- 534.232–14:621.395.61 939
Notes on Measurements of the Efficiency of Transducers for Water-Borne Sounds—H. Thiede. (*Akust. Beihefte*, no. 3, pp. 449–451; 1953.) A method particularly applicable in the sonic and lower ultrasonic frequency ranges is described. Measurements of power absorbed for constant excitation at frequencies well below, well above and at the mechanical resonance frequency are made, the last-mentioned measurement being repeated with the transducer radiating in air. Efficiency can then be calculated.
- 534.321.9 940
Intensities Produced by Jet-Type Ultrasonic Vibrators—H. O. Monson and R. C. Binder. (*Jour. Acous. Soc. Amer.*, vol. 25, pp. 1007–1009; Sept., 1953.) An investigation of the influence of inlet pressure, cup position and physical proportions on the intensity and frequency of the vibrations.
- 534.414:534.845 941
The Impedance of a Resistance-Loaded Helmholtz Resonator—U. Ingard and R. H. Lyon. (*Jour. Acous. Soc. Amer.*, vol. 25, pp. 854–857; Sept., 1953.) Resonators with a damping screen are considered, and the dependence of the impedance on the distance between screen and aperture is investigated theoretically; the resistance and reactance components are differently affected. The results are discussed in relation to the design of perforated facings.
- 534.62+621.317.3.029.63/64 942
A New Anechoic Chamber for Sound Waves and Short Electromagnetic Waves—E. Meyer, G. Kurtze, H. Severin, and K. Tamm. (*Akust. Beihefte*, no. 3, pp. 409–420; 1953.) Description of the design and construction of a chamber of dimensions 5.5m×10m×14m, with a reflection factor < 10 per cent for sound waves of frequency > 70 cps and for em waves of frequency > 1 kmc. The treatment of the walls is basically similar to that in the pre-war anechoic chamber at the Technische Hochschule, Charlottenburg [6 of 1948 (Meyer et al.)], but behind the fibreglass wedges a cavity 12 cm deep has been provided which together with slots between the wedges, forms a resonator system. Graphite powder drawn into the wedges by suction provides the attenuation of the em waves.
- 534.62 943
On the Measurement of Power Radiated from an Acoustic Source—W. G. Cady and C. E. Gittings. (*Jour. Acous. Soc. Amer.*, vol. 25, pp. 892–896; Sept., 1953.) An account is given of experiments which verified the theory developed by Borgnis (2536 of 1953). A slab of pc rubber, a 90 degree wedge and a cavity radiometer were used as absorbers.
- 534.78 944
General Analysis of the Acoustic Structure of Speech Sounds by the Superposition of Periodic and Random Components—R. Husson and R. Saumont. (*Compt. Rend. Acad. Sci., (Paris)*, vol. 237, pp. 1555–1556; Dec. 9, 1953.) A discussion of the physiological origin of the different types of component and of the ability of the ear to discriminate between them. A new classification of phonemes is given.
- 534.78 945
A Study of the Building Blocks in Speech—C. M. Harris. (*Jour. Acoust. Soc. Amer.*, vol. 25, pp. 962–969; Sept., 1953.) A technique is used in which speech elements are recorded on magnetic tape and joined together as required.
- 534.78 946
A Speech Synthesizer—C. M. Harris. (*Jour. Acoust. Soc. Amer.*, vol. 25, pp. 970–975; Sept., 1953.) The device uses a keyboard arrangement to select for reproduction speech elements magnetically recorded on a drum.
- 534.78 947
Some Experiments on the Recognition of Speech, with One and with Two Ears—E. C. Cherry. (*Jour. Acous. Soc. Amer.*, vol. 25, pp. 975–979; Sept., 1953.)
- 534.832 948
Vibration of Plates Covered with a Damping Layer—A. van Itterbeek and H. Myncke. (*Acustica*, vol. 3, pp. 207–212; 1953.) The time taken for a halving of the initial amplitude was determined experimentally for steel plates 3–26 mm thick. The variation with the mass of paint used and with temperature is shown graphically.
- 534.832:534.121.1 949
Sound Radiation from Plates Excited in Flexural Vibration—K. Gösele. (*Acustica*, vol. 3, pp. 243–248; 1953. In German.) The sound energy radiated per unit area of the plate is a function of the ratio f/f_{cr} where f is the frequency of the sound and f_{cr} the critical frequency of the plate. For values of this ratio > 1 the radiation is independent of the total area of the plate, for unity value the radiation increases with the area and for values < 1 it decreases to a limiting value. The application of the theoretical results to the construction of single- and double-shell walls is mentioned.
- 534.84 950
Room Acoustics—H. J. Sabine. (*Trans. I.R.E.*, vol. AU-1, pp. 4–12; July/Aug., 1953.) A brief survey of the transmission of sound through the air in a room, and of the ways in which a sound signal may be modified by the acoustic characteristics of the room.
- 534.84 951
Measurements of the Acoustical Properties of Two Roman Basilicas—A. C. Raes and G. G. Sacerdote. (*Jour. Acous. Soc. Amer.*, vol. 25, pp. 954–961; Sept., 1953.)
- 534.845–14 952
Pulse Method of Measurement of the Reflection from Absorbers of Water-Borne Sound in Tubes—W. Kull, H. Oberst, and E. Skudrzyk. (*Akust. Beihefte*, no. 3, pp. 421–433; 1953.) Measurements are made on a cro of the amplitude of pulses reflected from resonance-type absorbers at the end of a water-filled tube. Pulse durations between 0.5 and 1.5 ms are used, with frequencies in the range 9–22 kc. Sources of error, and their elimination, are considered in detail.
- 621.395.61 953
Derivation of the Laws of Force for All Magnetic and All Electric Transducers from a Single Law in Each Case—F. A. Fischer. (*Akust. Beihefte*, no. 3, pp. 441–448; 1953.) If the magnetic energy of a system of two coupled coils and the electric energy of two coupled electric conductors respectively are calculated, the mechanical force is given by the derivative of the energy with respect to x , assuming that the x co-ordinate is the only one along which the system varies. The different types of transducers result from a proper choice of this variable co-ordinate.
- 621.395.61 954
The Theoretical Sensitivity of Three Types of Rectangular Bimorph Transducers—E. G. Thurston. (*Jour. Acous. Soc. Amer.*, vol. 25, pp. 870–872; Sept., 1953.) Application of the method discussed previously (926 of 1953) to the cases of (a) the corner-loaded square bimorph, (b) the rectangular bimorph supported along two sides and uniformly loaded, and (c) the rectangular bimorph loaded only along a strip.
- 621.395.61 955
A Miniature Piezoelectric Microphone—J. Medill. (*Jour. Acous. Soc. Amer.*, vol. 25, pp. 864–866; Sept., 1953.) A Rochelle-salt microphone developed for use as a secondary standard in acoustic testing has a diameter of 1½ inch. Details are given of its construction and performance.
- 621.395.61 956
A Miniature Microphone for Transistorized Amplifiers—B. B. Bauer. (*Jour. Acous. Soc. Amer.*, vol. 25, pp. 867–869; Sept., 1953.) The construction and performance of a moving-iron microphone suitable for use in hearing aids are described.
- 621.395.612.451 957
The Uni axial Microphone—H. F. Olson, J. Preston, and J. C. Bleazey. (*Trans. I.R.E.*, vol. AU-1, pp. 12–19; July 1, Aug., 1953.) Reprint. See 2199 of 1953.
- 621.395.623.7:534.321.9 958
Interaction of Two Ultrasonic Waves in Air—J. Maulois. (*Toute la Radio*, vol. 20, pp. 352–354; Nov., 1953.) Report of experiments made by S. Klein using two ionophone loudspeakers to produce either (a) unmodulated waves of slightly different frequencies, or (b) an unmodulated and a modulated wave of the same carrier frequency. Audible beats were produced. The possibility of designing a loudspeaker requiring neither horn nor baffle is discussed.
- 621.395.623.7.011.21 959
Loudspeaker Impedance—V. Salmon. (*Trans. I.R.E.*, vol. AU-1, pp. 1–3; July/Aug., 1953.) The operation and testing of loudspeakers, and the calculation of available input power, require knowledge of five impedances, which are here discussed and defined. In estimating loudspeaker performance with different output stages or at extreme frequencies, the source regulation is an important factor. Its measurement is described.

ANTENNAS AND TRANSMISSION LINES

- 621.315.212 960
Modern Coaxial-Cable Technique in Great Britain—E. Baguley. (*Elec. Commun.*, vol. 30, pp. 186–216; Sept., 1953.) A discussion of the design, manufacture, and testing of long-distance telephone and television wide-band coaxial cables. Comparative performance figures and curves for cables made between 1935 and 1950 are given. The tests described include a 5-kv flashover test, pulse-echo test for detecting irregularities of impedance, HF attenuation measurement, impedance measurement between 50 kc and 10 mc and cross-talk measurements.
- 621.315.212:621.372.2 961
The Transmission Characteristics of Coaxial Cables—E. Adam. (*Öst. Z. Telegr. Teleph. Funk Fernseh. tech.*, vol. 7, pp. 98–107 and 122–134; July/Aug. and Sept./Oct., 1953.) A simple treatment of the subject based on work published by various authors, from Maxwell up to the present time.
- 621.372.2 + 538.566 962
The Effect of the Radiation Condition in the case of Complex Wave Number, and its Significance in the Problem of Surface Waves—Haug. (See 1162.)
- 621.372.2 963
Normalized Impedance and Reflection Coefficient—P. A. Lindsay. (*Wireless Eng.*, vol. 31, pp. 43–47; Feb., 1954.) Starting from the formula giving the impedance Z at the end of a transmission line of length l in terms of the characteristic impedance Z_0 , the propagation constant and l , perspective drawings are constructed of surfaces representing the relations between the normalized load impedance Z/Z_0 and the voltage coefficient of reflection.
- 621.372.2:537.226 964
Propagation in a Dielectric Transmission Line—M. Jouguet. (*Compt. Rend. Acad. Sci.*, (Paris), vol. 237, pp. 1656–1657; Dec., 1953.) In addition to the E_0 and H_0 modes, mixed modes with m -order symmetry round the circumference of the line can exist. Two infinite series of modes designated $(EIH)_{m,n}$ and $(EIH)''_{m,n}$ correspond to any value of m . The values of the cut-off frequency, phase velocity and attenuation are determined for various cases.
- 621.372.2 + 538.566]:621.3.012 965
New Chart for the Solution of Transmission-Line and Polarization Problems—G. A. Deschamps. (*Elect. Commun.*, vol. 30, pp. 247–254; *Trans. I.R.E.*, vol. MTT-1, pp. 5–13; March, 1953.) This chart, an orthographic projection of the Poincaré sphere (see 2418 of 1951), is considered as a modification of the Smith chart. It is normally used with a hyperbolic protractor. The examples given of its applications include the evaluation of the reflection coefficient of a stratified medium and of junction-insertion loss. Polarization problems are treated by assimilating polarization ratio to reflection coefficient.
- 621.372.43 966
Transmission-Line Matching System—R. E. Collin and J. Brown. (*Wireless Eng.*, vol. 31, pp. 31–35; Feb., 1954.) The two-section quarter-wave transformer is analyzed. By tolerating a certain mismatch at the center of the band it is possible to obtain a perfect match at two frequencies located symmetrically about the center frequency. This arrangement gives an increase of 20–45 per cent in bandwidth over the commonly used binomial transformer, which gives perfect matching at the center frequency only. Simple design procedure and performance curves are presented.
- 621.372.8 967
Velocity of Energy in Waveguides—G. Sincich. (*Alta Frequenza*, vol. 22, pp. 239–243; Oct., 1953.) A calculation is made of the in-

stantaneous energy velocity for the TM or TE mode. The velocity is always less than that for a free wave; its value is zero, maximum or equal to the group velocity according as the longitudinal component of the electric field (for the TM mode) or the magnetic field (for the TE mode) is maximum, zero, or equal to its rms value respectively.

- 621.372.8 968
On the Propagation Constant in Gentle Circular Bends in Rectangular Wave Guides—Matrix Theory—A. T. de Hoop. (*Jour. Appl. Phys.*, vol. 24, pp. 1325–1327; Oct., 1953.)

- 621.396.67 969
A Note on the Cylindrical Antenna of Non-circular Cross Section—Y. T. Lo. (*Jour. Appl. Phys.*, vol. 24, pp. 1338–1339; Oct., 1953.) The equivalent radii are derived for antennas of polygonal and elliptical cross section.

- 621.396.67.012.12 970
An Automatic Recorder of Aerial Radiation Diagrams—E. G. Hamer and J. B. L. Foot. (*Jour. Brit. I.R.E.*, vol. 14, pp. 33–42; Jan., 1954.) The instrument described compares a local af reference signal with an af signal of the same frequency and of amplitude proportional to the rf signal from the antenna. Arrangements are provided for mounting large aeriels at various heights, and for the presentation of results in different ways.

- 621.396.67.029.64:621.317.3 971
Measurements on Aeriels for Centimetre Waves—Bouix. (See 1127.)

- 621.396.674.3:538.566 972
The Interaction between Electromagnetic Wave and Dipole—F. Borgnis. (*Arch. elekt. Übertragung*, vol. 7, pp. 463–466; Oct., 1953.) The expression for the mean active power abstracted from the em wave by an electric or magnetic dipole is derived in terms of the electric or magnetic field, the length of the dipole (d), and the conjugate of the dipole complex current, from considerations of the near field. The expressions are valid for $d \ll \lambda$ and $r \ll \lambda$, where r is the distance from the dipole. The maximum effective cross-sectional area of either type of dipole with respect to a plane wave is shown to be $(3/8\lambda)\lambda^2$.

- 621.396.677.71 973
Vertically Polarized Microwave Antenna—R. K. Thomas and M. E. Ringenbach. (*Radio & Telev. News, Radio-Elec. Eng. Sec.*, vol. 50, pp. 13, 27; Oct., 1953.) A design giving a fan-shaped beam uses a stub-supported rigid coaxial line with longitudinally spaced circumferential slots.

- 621.396.677.71 974
Automatically Deiced X-Band Beacon Antenna—C. E. Thomas, Jr. (*Electronics*, vol. 27, pp. 152–155; Jan., 1954.) Details are given of a slotted-waveguide array with an omnidirectional radiation pattern and narrow vertical beam width, built to withstand wind velocities > 150 knots. The radome heating circuit is controlled by a bridge which includes a capacitor exposed to the weather.

- 621.396.677.859:621.396.96 975
Designing Radomes for Supersonic Speeds—S. S. Oleesky. (*Electronics*, vol. 27, pp. 130–135; Jan., 1954.) Designs which will not attenuate or distort the radar beam are discussed.

AUTOMATIC COMPUTERS

- 681.142 976
Phantastron computes Pulse-Width Ratios—L. D. Findley. (*Electronics*, vol. 27, pp. 164–167; Jan., 1954.) Description of an analog computer developed for determining the ratio of the widths of two pulses occurring simultaneously in two channels of a radar system. The output is readily convertible into digital form. Other applications are indicated.

- 681.142 977
Programme Control of an Electronic Computer—H. Harmuth. (*Acta Phys. austriaca*, vol. 7, pp. 390–401; Sept., 1953.)

- 681.142 978
Digital Computers at Manchester University—T. Kilburn, G. C. Tootill, D. B. G. Edwards, and B. W. Pollard. (*Proc. IEE*, part II, vol. 100, pp. 487–500; Oct., 1953.) An account is given of the development of the universal high-speed computer; its features include a cr tube store for 10,240 binary digits, an intermediate store for more than 280,000 digits, completely automatic transfer between the two stores, a fast multiplier, and input and output systems using 5-hole teleprinter tape.

- 681.142 979
The Construction and Operation of the Manchester University Computer—B. W. Pollard and K. Lonsdale. (*Proc. IEE*, part II, vol. 100, pp. 501–512; Oct., 1953. Discussion, pp. 540–543.) The account particularly stresses techniques used to achieve reliability and ease of maintenance, and includes details of the performance over a period of about 61 weeks. See also 978 above.

- 681.142 980
Universal High-Speed Digital Computers: a Decimal Storage System—T. Kilburn and G. Ord. (*Proc. IEE*, part II, vol. 100, pp. 513–522; Oct., 1953. Discussion, pp. 540–543.) Three decimal-digit storage systems using cr tubes are described. The best compromise as regards speed of operation, storage capacity and reliability is obtained with a cr-tube screen comprising ten separate elements. In a serially controlled store holding 32 words of 8 decimal digits the digit period was 40 μ s and could be reduced to 30 μ s. These results compare favorably with those for the binary store used in the Manchester University computer.

- 681.142:621–526 981
The Design and Testing of an Electronic Simulator for a Hydraulic Remote-Position-Control Servo Mechanism—F. J. U. Ritson and P. H. Hammond. (*Proc. IEE*, part II, vol. 100, pp. 568–569; Oct., 1953.) Discussion on 1054 of 1953.

- 681.142:621–526 982
Analogue Computers for Feedback Control Systems—R. A. Bruns. (*Trans. AIEE*, vol. 71, part II, pp. 250–254; 9152.)

- 681.142:621.314.222 983
Transformer-Analogue Network Analysers—M. W. H. Davies and G. R. Slemon. (*Proc. IEE*, part II, vol. 100, pp. 469–480; Oct., 1953. Discussion pp. 481–486.) The use of voltage transformers as multipliers for complex quantities is explained. A network analyzer is described comprising a measuring section and a number of identical panels each with two multiplying units. These panels can be used to represent impedances, admittances, etc. Negative resistance and unilateral mutual inductance can easily be represented. Applications discussed include the solution of linear simultaneous equations.

- 681.142:621.385 984
Valve Reliability in Digital Calculating Machines—L. Knight. (*Elec. Eng.*, vol. 26, pp. 9–13; Jan., 1954.) A discussion of measures which can be taken to reduce the number of tube failures and to reduce the inconvenience caused when failures do occur.

- 681.142:621.385.832 985
Recent Advances in Cathode-Ray-Tube Storage—F. C. Williams, T. Kilburn, C. N. W. Litting, D. B. G. Edwards, and G. R. Hoffman. (*Proc. IEE*, part II, vol. 100, pp. 523–539; Oct., 1953. Discussion, pp. 540–543.) Modifications have been made to the system described by Williams and Kilburn (2258 of 1949) and used in the Manchester University computer; the defocus-focus system and the signal ampli-

fier are discussed particularly. An account is given of experimental work undertaken to clarify the storage mechanism. The theoretical basis of the system is examined; the original theory, though inaccurate in detail, is satisfactory for practical purposes and can be used to predict storage results. The tube operation is analogous to that of a triode tube, the collector, bombarded spot, and surrounding screen surface corresponding respectively to the anode, cathode, and control grid.

CIRCUITS AND CIRCUIT ELEMENTS

621.318.572:621.385.832 986
A Multi-Decade Predetermined Counter—
 A. Dorn. (*Elec. Appl. Bull.*, vol. 14, pp. 91-101; June/July, 1953.) The automatic four-decade counter described is a modified version of that noted in 603 of February. The maximum counting rate is 12,500 per sec. and the minimum duration of a complete cycle of counts is $\frac{1}{3}$ ms.

621.372 987
Directional Coupling with Transmission Lines—
 W. L. Firestone. (*Tele-Tech.*, vol. 12, pp. 95-97, 178; Nov., 1953.) Adaptation of devices developed in connection with waveguides to forms with open-wire lines, for use at lower radio frequencies.

621.372 988
Response of an Amplifier Stage with Antiresonant Circuit to an Input Voltage whose Instantaneous Frequency varies linearly as a Function of Time—
 P. Poincelot. (*Compt. Rend. Acad. Sci., (Paris)* vol. 237, pp. 1314-1315; Nov. 23, 1953.) Analysis is given for an input which can be represented by a particular Fourier integral.

621.372.2:534.321.9 989
Equivalent-Network Representations for Solid and Mercury Delay Lines—
 S. Dairiki, T. E. Lawrence, and R. A. Mapleton. (*Jour. Acous. Soc. Amer.*, vol. 25, pp. 841-853; Sept., 1953.) An equivalent-network representation is obtained from consideration of the piezoelectric properties of the quartz crystal used to convert the electrical energy into ultrasonic energy. A formula is derived for the transfer function of the line. When mercury and fused-quartz lines are compared on the basis of the gain-bandwidth product only, the fused-quartz line is superior; but other factors (e.g. production of spurious signals) must be taken into account when selecting a line for a specific application.

621.372.413 990
Characteristics of an Elliptical Electromagnetic Resonant Cavity operating in the TE₁₁₁ Mode—
 T. P. Higgins and A. W. Straiton. (*Jour. Appl. Phys.*, vol. 24, pp. 1297-1299; Oct., 1953.) "Equations and graphs are presented of the resonant wavelength and quality factor of elliptical resonant cavities operating in the TE₁₁₁ mode. Both components of this mode are treated and distinctive characteristics of each are shown as a function of eccentricity of the cavity."

621.372.413 991
Interaction between Classical Electron and Quantized Electromagnetic Field—
 I. R. Senitzky. (*Phys. Rev.*, vol. 91, pp. 1309-1311; Sept. 13, 1953.) The equations of motion are solved by a method involving the corresponding difference equations, and an expression is derived for the probability of transition between a high-energy state and neighboring states of the field inside a resonant cavity.

621.372.5 992
The Transformation Properties of Loss-Free Quadripoles between Homogeneous Lines, and a Proof of Weissfloch's Transformation Law using Circle Geometry—
 H. Lueg. (*Arch. elekt. Übertragung*, vol. 7, pp. 478-484; Oct., 1953.) A method for evaluating certain parameters in the application of Weissfloch's transformation law (3287 of 1943 and back

references). This law has applications in measuring technique and circuit theory in the $cm-\lambda$ and $dm-\lambda$ regions.

621.372.5 993
On the Synthesis of Reactance 4-Poles—
 H. J. Carlin and R. La Rosa. (*Jour. Appl. Phys.*, vol. 24, pp. 1336-1337; Oct., 1953.) Using theory developed by Blevitch (1547 of 1952), formulas are derived for the elements of the impedance or admittance matrix of a loss-free quadripole which, when terminated by a resistor, realizes a prescribed physical driving-point impedance.

621.372.5.012 994
A Block-Diagram Approach to Network Analysis—
 T. M. Stout. (*Trans. AIEE*, vol. 71, part II, pp. 255-260; 1952.) An extension of the method described by Graybeal (1534 of 1952) to electrical networks, with examples of application in the analysis of ladder, bridged-*T* and parallel-*T* networks.

621.372.5.029.64:621.318:1 995
Ferrites in Microwave Applications—
 J. H. Rowen. (*Bell. Sys. Tech. Jour.*, vol. 32, pp. 1333-1369; Nov., 1953.) A discussion of the microwave Faraday effect and of the mechanism of power absorption in ferrites. Plane-wave theory is given, and is extended to cover waveguides. The measurement and applications of the effects are surveyed. See also 1233 of 1952 (Hogan).

621.372.512.029.63:621.372.21 996
Coupled Lines as High-Frequency Transformer—
 O. Bronder. (*Fernmeldelech. Z.*, vol. 6, pp. 475-480; Oct., 1953.) Systems comprising two parallel two-conductor lines are considered. Voltage and current distribution and input impedance are calculated in terms of terminating impedance, overlap length and coupling. An indication is given of the requirements to be satisfied for wide-band operation, and some particular arrangements are discussed.

621.372.54 997
Tentative Graphical Representation of the Image Transfer Coefficient of Ladder-Type Filters with or without Losses—
 J. E. Colin. (*Cables & Trans.*, vol. 7, pp. 242-262; July, 1953.) The method is based on the expression of the image transfer coefficient $p = a + jb$ as a function of frequency in accordance with the classification of filters given previously (2748 of 1949 and 575 of 1950).

621.372.543.2.029.5 998
A Set of 0.4-Octave Band-Pass Filters for Frequencies between 10 and 200 kc/s—
 H. Pursey. (*Electronic Eng.*, vol. 26, pp. 31-33; Jan., 1954.) Filters designed for eliminating harmonics are described. In order to achieve the desired sharp cut-off on the high-frequency side the filters are operated into an abnormally low impedance, about a tenth of the center-frequency impedance.

621.372.56:621.372.8 999
Broadband Rotary Waveguide Attenuator—
 B. P. Hand. (*Electronics*, vol. 27, pp. 184-185; Jan., 1954.) The attenuator comprises three collinear sections of round waveguide, each with a resistive film arranged in a diametral plane; the middle section is rotated to obtain the desired attenuation. Some performance figures are given for an experimental model; the characteristics are independent of frequency.

621.372.6 1000
A General Network Theorem, with Applications—
 B. D. H. Tellegen. (*Proc. I.R.E., (Australia)* vol. 14, pp. 265-270; Nov., 1953.) Slightly modified reprint of paper noted in 62 of 1953.

621.373.42 1001
"Chameleon" Oscillator—
 T. Roddam. (*Wireless World.*, vol. 60, pp. 52-55; Feb., 1954.) An oscillator giving high frequency sta-

bility and using relatively few components is based on a cathode-coupled Hartley circuit with resistance in the cathode lead.

621.373.421.13 1002
The Measure of Activity of Oscillators and the Performance Index—
 W. Herzog. (*Arch. elekt. Übertragung*, vol. 7, pp. 470-472; Oct., 1953.) The measure of activity of an oscillator is defined as the ratio of grid-voltage amplitude to anode-current amplitude. In crystal-controlled oscillators it is proportional to the crystal performance index. The measure of activity is evaluated for several common types of oscillator.

621.373.424.029.4 1003
Design of Heterodyne Oscillators—
 H. Lemmartz. (*Funk u. Ton*, vol. 7, pp. 526-534; Oct., 1953.) The choice of frequencies for producing a given beat frequency, and the design of the variable tuning capacitor are considered. Precautions required to ensure frequency stability are discussed.

621.373.43 1004
The Operation of Generators for Steep-Fronted Waves—
 J. Lagasse, J. Favarel, and P. Sido. (*Compt. Rend. Acad. Sci., (Paris)*, vol. 237, pp. 1151-1152; Nov. 9, 1953.) When the self-inductance of the generator is taken into account in the analysis, a third-order differential equation is obtained; simplification is introduced by taking advantage of a particular solution. Graphical methods of investigation, based on the work of Bergeron, are also outlined.

621.373.52 1005
Transistor Oscillator for Use in Multifrequency Pulsing Current Supply—
 F. E. Blount. (*Bell Sys. Tech. Jour.*, vol. 32, pp. 1313-1331; Nov., 1953.) Discussion of an oscillator for use in the transmission of digital information, at frequencies in the band 700-1700 cps, over telephone trunk-lines. Performance details are given.

621.374:621.318.572 1006
Introduction to the Use of Electronic Tubes in Pulse Techniques—
 P. A. Necteson. (*Elec. Appl. Bull.*, vol. 14, pp. 120-112; June/July, 1953.) Circuit phenomena produced by switching are briefly reviewed and the operation of tubes as nonlinear or switching elements is discussed as an introduction to the consideration of some well known pulse circuits.

621.374.33 1007
A Special Time-Discriminating Selector for Electronic Pulses—
 A. Alberigi, F. Lepri, and G. Stoppini. (*Nuovo Cim.*, vol. 9, pp. 365-368; April 1, 1952.) A circuit is described which is able to select the last of a series comprising an arbitrary number of pulses distributed in an arbitrary way within a fixed time interval.

621.375.1:621.396.822 1008
Determination of the Noise Factor of Various Amplifiers by a Comparison Method—
 W. Mansfeld. (*Funk u. Ton*, vol. 7, pp. 501-507; Oct., 1953.) The relative noise factor can be determined by using a standard-type signal generator connected to the input of the amplifier and a band-pass filter coupled to a tube voltmeter at the output.

621.375.232 1009
Wide-Band I.F. Amplifiers—
 H. S. Jewitt. (*Wireless World.*, vol. 60, pp. 86-90; Feb., 1954.) Bandwidths > 10 mc, such as are required for dealing satisfactorily with very short pulses, are achieved without necessitating alignment of the amplifier with a particular set of tubes, by using a negative-feedback design technique. The amplifier is treated as a series of pairs of tubes, the first of each pair operating without and the second with feedback. A table gives component values in a form requiring a minimum of computation. A particular 12-stage amplifier designed by this method for a centre frequency of 60 mc had a bandwidth of 20 mc to the -1db points and an over-all gain of about

90 db; the response varied only very slightly when all the tubes were changed.

621.375.3 1010
Magnetic Amplifier uses Conventional Inductors—A. I. Bennett, Jr. (*Electronics*, vol. 27, pp. 181–183; Jan., 1954.)

621.375.3 1011
Negative Inductance cuts Magnetic-Amplifier Lag—G. M. Ettinger. (*Electronics*, vol. 27, pp. 162–163; Jan., 1954.) The speed of response of a magnetic amplifier is improved, without reducing its sensitivity, by balancing out the effect of control-circuit inductance by means of a “negative-inductance” device comprising a valve with an iron-cored mutual inductor.

621.375.3.024 1012
The Design of a Practical D. C. Amplifier Based on the Second-Harmonic Type of Magnetic Modulator—S. W. Noble and P. J. Baxandall. (*Proc. IEE*, part II, vol. 100, pp. 567–570; Oct., 1953.) Discussion on 72 of 1953.

621.375.4 1013
Transistors: Theory and Application: Part II—Cascading Transistor Amplifier Stages—A. Coblenz and H. L. Owens. (*Electronics*, vol. 27, pp. 158–161; Jan., 1954.) Formulas and values of circuit parameters are tabulated for various possible arrangements using point-contact or junction transistors.

621.375.4.029.3:621.314 1014
Power Transistors for Audio Output Circuits—Giacoletto. (*See* 1247.)

621.396.822:621.372 1015
Physical Basis of Thermal Noise—D. A. Bell. (*Wireless Eng.*, vol. 31, pp. 48–50; Feb., 1954.) An examination is made of methods developed by various workers for analyzing circuit noise due to random motion of charge carriers. It is concluded that it is not necessary to postulate thermodynamic equilibrium in order to be able to calculate the thermal noise.

621.375.4+621.373.52 1016
Principles of Transistor Circuits [Book Review]—R. F. Shea (Ed). Publishers, Chapman & Hall, London, 535 pp., 88s. (*Wireless Eng.*, vol. 31, pp. 51–52; Feb., 1954.) A comprehensive work on transistors and their circuitry, written by nine members of the staff of the electronics laboratory of the G.E.C. Company of America.

621.376+621.314.26 1017
Modulators and Frequency Changers [Book Review]—D. G. Tucker. Publishers: Macdonald & Co., London, 232 pp., 28s. (*Brit. Jour. Appl. Phys.*, vol. 4, p. 319; Oct., 1953.) For research, development, and maintenance engineers. High-power transmitting modulators are not treated.

GENERAL PHYSICS

534.014.5 1018
Graphical Presentation of Oscillator Resonance, Applicable to the Study of Nonlinear Systems—P. Liénard. (*Acustica*, vol. 3, pp. 212–223; In French.)

535.31:535.13 1019
Derivation of the Laws of Geometrical Optics from Maxwell's Field Theory—G. Mandl. (*Acta Phys. austriaca*, vol. 7, pp. 365–389; Sept., 1953.)

535.42:538.56:621.372.8 1020
The Diffraction of Electromagnetic Waves by a Semi-infinite Circular Waveguide—J. D. Pearson. (*Proc. Camb. Phil. Soc.*, vol. 49, part 4, pp. 659–667; Oct., 1953.) Formulas are obtained for the currents on the waveguide, and asymptotic expressions are derived for the longitudinal components of the electric and magnetic vectors in the waveguide at large distances from the mouth.

537.122:538.56 1021
A Collective Description of Electron Interactions: Part 2—Collective vs Individual Particle Aspects of the Interactions—D. Pines and D. Bohm. (*Phys. Rev.*, vol. 85, pp. 338–353; Jan. 15, 1952.) Part 1: 2975 of 1951.

537.221:546.47 1022
The Electromotive Force developed by a Creeping Zinc Crystal—F. D. Coffin and S. L. Simon. (*Jour. Appl. Phys.*, vol. 24, pp. 1333–1334; Oct., 1953.)

537.311.1 1023
Theory of Plasma Waves in Metals—P. A. Wolff. (*Phys. Rev.*, vol. 92, pp. 18–23; Oct. 1, 1953.) The Hartree approximation is used to investigate the effect of the crystal lattice on plasma oscillations in metals. A formula is derived for the oscillation frequency; for free electrons this reduces to that given by Bohm and Gross (88 and 89 of 1950); for insulators there are no oscillations. In metals with occupied d bands there is strong coupling between the plasma oscillations and the d electrons, causing frequency broadening.

537.311.33 1024
Theory of A.C. Space-Charge Polarization Effects in Photoconductors, Semiconductors, and Electrolytes—J. R. MacDonald. (*Phys. Rev.*, vol. 92, pp. 4–17; Oct. 1, 1953.) Linear theory is developed for solid or liquid materials containing charge carriers which can move freely within the material but are blocked by the electrodes. The carriers may be electrons, holes, ions or ion vacancies. The general solution for the admittance of the material is obtained for an arbitrary ratio between the mobilities of positive and negative carriers, and is discussed for some special cases. Results are compared with those derived from other theories.

537.525.5 1025
The Field-Emission-Initiated Vacuum Arc: Part 1—Experiments on Arc Initiation—W. P. Dyke, J. K. Trolan, E. E. Martin, and J. P. Barbour. (*Phys. Rev.*, vol. 91, pp. 1043–1054; Sept. 1, 1953.) The experiments were carried out under conditions of high vacuum and clean cathode surface. Results show (a) that breakdown is immediately preceded by recognizable emission anomalies, (b) that breakdown occurs at a critical current density of the order of 10^8 A/cm², for applied microsecond pulses in the range 8.8–60.1 kv, and (c) that breakdown is independent of cathode bombardment.

537.525.5 1026
The Field-Emission-Initiated Vacuum Arc: Part 2—The Resistively Heated Emitter—W. W. Dolan, W. P. Dyke, and J. K. Trolan. (*Phys. Rev.*, vol. 91, pp. 1054–1057; Sept. 1, 1953.) Theory is developed for the heat flow in an emitter of geometry approximating to that used in the experiments reported in 1025 above. The calculations support the view that breakdown is initiated by a resistive heating process.

537.533:537.525.92 1027
Space-Charge Effects in Field Emission—J. P. Barbour, W. W. Dolan, J. K. Trolan, E. E. Martin, and W. P. Dyke. (*Phys. Rev.*, vol. 92, pp. 45–51, Oct. 1, 1953.) “A progressive reduction of the observed field current below values expected from the empirical law for increasing values of the potential is attributed to space charge. The current density expected in the presence of space charge is calculated from the Fowler-Nordheim field emission theory using values of the cathode electric field obtained from a solution of Poisson's equation for plane electrodes with boundary conditions appropriate to field emission. The result is a generalization of Child's equation, and is asymptotic to it when the applied potential is large compared with the value required for appreciable field emission.”

537.533:538.691 1028
“Brillouin Flow” with Thermal Velocities—

J. R. Pierce and L. R. Walker. (*Jour. Appl. Phys.*, vol. 24, pp. 1328–1330; Oct., 1953.) “A type of electron flow in a constant magnetic field is described. The beam of electrons is supposed to be everywhere in thermal equilibrium and the usual Brillouin flow is found when the equilibrium temperature tends to zero. Some considerations are put forward bearing on the choice of a suitable beam temperature in specific problems.”

537.533.8 1029
A Modified Theory of Production of Secondary Electrons in Solids—A. van der Ziel. (*Phys. Rev.*, vol. 92, pp. 35–39; Oct. 1, 1953.) Difficulties in previous theories of energy loss and secondary-electron production in metals [see e.g. 3069 of 1952 (Dekker and van der Ziel)] are removed by replacing the Coulomb interaction between a primary electron and a lattice electron by a screened Coulomb interaction.

537.56:538.63 1030
Magnetic-ionic Theory of Weakly Ionized Gases in the Presence of an Oscillating Electric Field and a Constant Magnetic Field—R. Jancel and T. Kahan. (*Jour. Phys. Radium*, Oct., 1953.) The velocity distribution functions for a nonuniformly ionized gas are calculated by solving the Boltzmann differential equations. Explicit expressions are derived for the magneto-ionic conductivity, the dielectric tensor, the Hall effect, the deflection of the electron beam and the generalization of Langevin's mobility formula. Comparison is made with other methods of calculation.

537.562:538.63 1031
The Conductivity Tensor of Electros Plasmas in the presence of a Constant Magnetic Field—M. Bayet, J. L. Delcroix, and J. F. Denisse. (*Compt. Rend. Acad. Sci.*, (Paris), vol. 237, pp. 1503–1505; Dec. 9, 1953.) Assuming the mean collision frequency to be independent of velocity, it is shown that the form of the conductivity tensor given by Jancel and Kahan (1030 above) differs from that given by Huxley (1266 of 1952). In order to represent the magneto-resistance terms correctly by Jancel and Kahan's method, closer approximation is necessary.

538.22 1032
Some Magnetic Properties of Metals: Part 6—Surface Corrections of the Landau Diamagnetism and the de Haas-van Alphen Effect—R. B. Dingle. (*Proc. Roy. Soc. A.*, vol. 219, pp. 463–477; Oct. 7, 1953.) An expression is given for the magnetic moment of a large but finite system of electrons in terms of the volume and two mutually perpendicular surface areas together with constants independent of the shape of the system. The theory is verified by calculating the values of the constants for two different shapes. Corrections to part 5 (1967 of 1953) are noted.

538.221 1033
A Two-Electron Example of Ferromagnetism—J. C. Slater, H. Stutz, and G. F. Koster. (*Phys. Rev.*, vol. 91, pp. 1323–1341; Sept. 15, 1953.) The method of dealing with problems of ferromagnetism on the basis of energy-band theory [*Rev. Mod. Phys.*, vol. 25, p. 199; 1953. (Slater)] is applied to a simple case.

538.51 1034
The Law of Induction—G. Vallauri. (*Alta Frequenza*, vol. 22, pp. 211–238; Oct., 1953.) A survey of the literature indicates a lack of clarity on this subject. The law of induction is formulated generally in terms of a geometrical entity called the “flux line,” which exists in the field of a solenoidal vector.

538.52 1035
Induction Phenomena consequent on the Movement of Material in Primary Magnetic Fields, and their Experimental Applications: Part 3—Fundamental Theory for Very General

Cases—H. Hinteregger. (*Acta Phys. austriaca*, vol. 7, pp. 337-354; Sept., 1953.) Theory applicable to any type of motion is developed. Part 2: 388 of March.

538.561:537.533 1036
Motion of an Electron in a Magnetic Undulator—R. Combe and M. Feix. (*Compt. Rend. Acad. Sci., (Paris)*, vol. 237, pp. 1318-1320; Nov. 23, 1953.) Rigorous solutions are obtained for the equations of motion of an electron in a millimeter-wave generator of the type described by Motz et al. (3582 of 1953).

538.561:537.533 1037
Frequencies and Power of Waves Radiated by a Magnetic Undulator—R. Combe and M. Feix. (*Compt. Rend. Acad. Sci., (Paris)* vol. 237, pp. 1660-1662; Dec. 21, 1953.) Continuation of investigation noted in 1036 above. The dimensions of an undulator for generating mm waves are determined from rigorous calculations of electron trajectories. The results differ greatly from values derived from classical theory. The values found for radiated power are of the same order.

538.566:537.56 1038
The Equations of Propagation of Electromagnetic Waves in an Ionized Gas—A. M. Confetta. (*R. C. Ist. Lombardo*, vol. 85, pp. 495-502; 1952.) Two different methods are used to derive the equations for the propagation of em waves in an ionized gas subjected to a time-varying em field and to a constant magnetic field; terms depending on past states are found to occur.

538.566.029.64:535.51-7 1039
Effect of a Metal Plate on Total Reflection W. Culshaw and D. S. Jones. (*Proc. Phys. Soc.*, vol. 66, pp. 859-864; Oct., 1, 1953.) The phase changes which occur on total reflection are modified when a metal plate is placed near and parallel to the reflecting boundary. By moving the plate, the phase difference between plane waves of equal amplitudes polarized in and perpendicular to the plane of incidence can be varied from $-\pi$ up to the positive value obtained without the plate. This has been confirmed experimentally using a wavelength of 1.25 cm and a 45 degrees perspex prism. When the refractive index is $\geq 1 + \sqrt{2}$, there are two positions of the plate for which the reflected wave is circularly polarized, the electric vector rotating in opposite directions for these two positions.

538.566.2 1040
Theory of a [linear] Conductor near the Boundary of Two Media—A. A. Pistol'kors. (*Compt. Rend. Acad. Sci. U.S.S.R.*, vol. 86, pp. 941-943; Oct. 11, 1952. In Russian.) The electromagnetic field due to an oscillation of angular frequency ω in the conductor can usually be split into two components: a cylindrical-wave field and a spherical-wave field. Near the axis of the conductor, which is parallel to the boundary plane, the field is of a special type. The condition for the existence of the two components is derived and applied to particular cases.

538.691 1041
Deflection of High-Energy Electrons in Magnetized Iron—S. Berko and F. L. Hereford. (*Phys. Rev.*, vol. 91, pp. 1127-1130; Sept. 1, 1953.) The effective magnetic field acting on electrons traversing a ferromagnetic medium is shown, by experiments, to be equal to the flux density.

GEOPHYSICAL AND EXTRATERRESTRIAL PHENOMENA

523.5:621.396.96 1042
Radio Echo Studies of Meteor Ionization—T. R. Kaiser. (*Advances Phys.*, vol. 2, pp. 495-544; Oct., 1953.) The physical properties of the meteors and the columns of ionization which they produce, and the properties of the atmosphere in the meteor ionization region were

investigated using, mainly, pulse equipment operating in the 4-10-m waveband. The development of a satisfactory theory of scattering of radio waves from meteor trails, together with the theory of evaporation from meteors, makes possible the detailed interpretation of the radio echoes obtained. In particular, the estimated incident flux of meteors is found to be sufficient to maintain a continuous ionospheric layer extending from ~ 130 km down to 115 km, below which ionization will be distributed in patches becoming fewer (and larger) with decreasing height. Over 40 references.

523.72:621.396.822 1043
Observations of Solar Radio-Noise Storms—B. Vauquois, P. Coupiac, and M. Laffineur. (*Compt. Rend. Acad. Sci., (Paris)* vol. 237, pp. 1630-1632; Dec. 21, 1953.) Observations indicate that simple storms, i.e. those caused by a single bipolar group of sunspots, exhibit a directional effect varying with wavelength.

523.745:621.396.822.029.62 1044
Radio Noise Bursts from Solar M-Regions—A. K. Das and B. N. Bhargava. (*Nature, (London)*, vol. 172, pp. 855-856; Nov. 7, 1953.) The passage of M-regions is characterized by a notable increase in the short-term variability of noise intensity at 3 m λ .

523.755:537.56 1045
Ionization and Recombination Processes in a Plasma and the Ionization Formula of the Solar Corona—G. Elwert. (*Z. Naturf.*, vol. 7a, pp. 432-439; June, 1952.) For a plasma not in thermodynamic equilibrium, formulae are derived for (a) the photo-ionization, (b) the ionization by collisions, (c) the recombination with emission of light, and (d) the recombination due to triple collisions. By equating the number of collision ionizations with the number of photo-recombinations, an ionization formula is obtained for the solar corona from which the temperature of the corona can be estimated.

523.852:621.396.822.029.62 1046
Radio-Frequency Radiation from the Spiral Nebula Messier 81—R. H. Brown and C. Hazard. (*Nature, (London)*, vol. 172, p. 853; Nov. 7, 1953.) The intensity measurement of radio source observed has been combined with previous observations to determine the ratio between the radio flux and the light flux for individual nebulae. The calculated flux from a nebula of apparent magnitude +10 (Shapley-Ames) is $\sim 4.2 \times 10^{-26}$ W/m²/(cps) at 158.5 mc.

523.852.3:621.396.822 1047
An Extended Radio-Frequency Source of Extragalactic Origin—R. H. Brown and C. Hazard. (*Nature, (London)*, vol. 172, pp. 997-998; Nov. 28, 1953.) Extension of observations noted in 2215 of 1952.

550.3:519.2 1048
Statistical Analysis of Geophysical Time Series—R. P. W. Lewis, and D. H. McIntosh. (*Met. Mag., (London)*, vol. 82, pp. 239-242; Aug., 1953.) Notes are provided on dealing with the effects of linear and periodic trends on standard deviation and correlation coefficient. Significant tests in coherent series are discussed.

550.384 1049
The Phased-Superposed-Epoch Method of Analysis, and an Application to Geomagnetic Activity—E. J. Chernosky. (*Trans. Amer. Geophys. Union*, vol. 34, pp. 519-528; Aug., 1953.) A method is described in which geomagnetic-activity variations are analyzed by grouping the data according to their phases (increasing, decreasing, or no-change), as determined by considering the characteristics for pairs of successive days.

550.384:523.74/.75 1050
Geomagnetic Activity and the Sunspot Cycle—R. Ananthakrishnan. (*Nature, (London)*, vol. 172, pp. 854-855; Nov. 7, 1953.) A table is given, for the last four sunspot-maximum epochs, of the numbers of magnetically

calm days and of slightly, moderately and highly disturbed days, together with sunspot numbers and a measure of the prominence activity. Geomagnetic activity shows correlation with prominence activity rather than with sunspot activity.

550.384.4 1051
Diurnal Magnetic Variations near the Magnetic Equator—S. K. Pramanik and P. S. Hariharan. (*Indian Jour. Met. Geophys.*, vol. 4, pp. 353-358; Oct., 1953.) Observations made at nine places in South India are analysed in conjunction with observations for South America. High diurnal ranges of H occur in a belt of 5 degrees to 6 degrees of latitude, with a maximum near the magnetic equator.

551.510.535 1052
Abnormal Ionospheric Absorption observed during February, 1952—R. Eyfrig. (*Ann. Geophys.*, vol. 9, pp. 325-327; Oct./Dec., 1953.) Observations from stations all over the world are analyzed. Very high absorption was observed during the period 24th-28th, February within a limited region. The eastern and western limits of the affected region are not known accurately, because of the sparseness of stations; no effect was observed in America or in the far east. The southern limit was observed in Africa, roughly along the line joining Casablanca and Djibouti. An explanation involving corpuscular radiation fits the observations better than one based directly on wave radiation from the sun. The absorption is thought to occur in low-altitude ionized layers such as that detected by Gnanalingam and Weekes (3427 of 1952).

551.510.535 1053
A Self-Consistent Calculation of the Dissociation of Oxygen in the Upper Atmosphere: Part 2—Three-Body Recombinations—H. E. Moses and Ta-You Wu. (*Phys. Rev.*, vol. 91, pp. 1408-1409; Sept. 15, 1953.) Continuation of work noted in 102 of 1953. Results based on the assumption that recombination occurs mainly as a three-body nonradiative process indicate that dissociation occurs at a level about 5 km higher than that previously calculated.

551.510.535 1054
Bifurcation of the E Region—J. R. Lien, R. J. Marcou, J. C. Ulwick, D. R. McMorrow, D. B. Linsford, and O. C. Haycock. (*Phys. Rev.*, vol. 92, pp. 508-509; Oct. 15, 1953.) The retardation time, relative to an uhf reference signal, of a radio signal of frequency about 1 mc above the critical frequency was measured by rocket-borne instruments. Electron-density/altitude graphs were derived from the retardation-time/time-of-flight records; bifurcation of the E layer is clearly indicated. The results are in close agreement with those calculated from records obtained with the N.B.S. Model C-3 ionosphere recorder. The separation of the electron-density maxima was 13-18 km.

551.510.535 1055
Direction-Finding Studies of Large-Scale Ionospheric Irregularities—E. N. Bramley. (*Proc. Roy. Soc. A*, vol. 220, pp. 39-61; Oct. 22, 1953.) Continuation of work noted in 3091 of 1951 (Bramley and Ross). A report is given of measurements on pulse-modulated transmissions in the frequency range 2-15 mc, reflected from the ionosphere. Both vertical-incidence and oblique-incidence observations were made. The directional variations of the reflected signals were studied, and are interpreted as due to tilting or wrinkling of the constant-ionic-density surfaces in the ionosphere. The results indicate large-scale horizontal movements in the ionosphere. In the E₁ layer these appear to be of the nature of drifting clouds of ionization, while in the F layer the effects are consistent with horizontally travelling ripples having wavelengths of 50-400 km and speeds up to 350 m/s. The direction of motion is more often towards east or west than towards north or

south, and evidence of a diurnal variation has been observed.

551.510.535 1056

Reflexions from Irregularities in the Ionosphere—G. H. Munro. (*Proc. Roy. Soc. A*, vol. 219, pp. 447-463; Oct. 7, 1953.) Complexities in records of $h'f$ and $h'f$ for the F region are shown to be due to curvature of the reflecting surface. The order of curvature associated with travelling disturbances is calculated and the variation in the type of complexity is shown to result from differing group retardations in the different paths. A 50-km-base triangular system of three 5.8-mc pulse-transmitters, and a panoramic type 1-15-mc recorder were used respectively for $h'f$ and $h'f$ recording.

551.510.535 1057

Examination of the Formation of the Ionosphere F Region—K. Rawer and E. Argence. (*Ann. Geophys.*, vol. 9, pp. 1-25; Jan./March, 1953.) Continuation of work noted in 987 of 1952 (Rawer et al.). Two different possible mechanisms are discussed, namely (a) photoionization of O_2 , and (b) ionization by soft X rays. The photoionization hypothesis is only acceptable if the dissociation of the O_2 is assumed to take place at a relatively high altitude of about 130 km. Ionization by X rays of solar origin certainly occurs, but a recent calculation of the spectral distribution of solar energy indicates too high an ionization at 95-110 km.

551.510.535 1058

Recombination Coefficient in the F-Regions: a Possible New Process of Ionization of Nitrogen Molecules—R. B. Banerji, (*Nature*, (London), vol. 172, pp. 953-954; Nov., 21, 1953.) Discussion of a possible dissociative recombination process according to which the daytime solar radiation at visible wavelengths may be instrumental in ionizing nitrogen molecules if positively charged particles are present.

551.510.535:523.78 1059

The Solar Eclipse of 25-2-1952 at Gao—F. Delobau. (*Ann. Geophys.*, vol. 9, pp. 317-324; Oct./Dec., 1953.) Ionosphere observations made during the eclipse are reported. Though the occultation was only partial, a diminution of E - and F_2 -layer ionization compared with normal days was observed; the effect was very pronounced at 0735 hours U.T., when the sunspot near the western limb of the sun was obscured. On the other hand, when this sunspot disappeared on 26th February, as a result of the rotation of the sun, there was no noticeable reduction of the E -layer ionization. The effect is difficult to explain in terms of classical theory. The diminution of ionization of the F_2 layer is significant.

551.510.535"1953":621.396.11 1060

Ionosphere Review: 1953—T. W. Bennington. (*Wireless World*, vol. 60, pp. 66-68; Feb., 1954.) Twelve-month running averages and monthly-mean values are plotted for the sunspot numbers and the noon and midnight F_2 critical frequencies from 1947. It is inferred that the critical frequencies are likely to decrease only very slightly before the next sunspot minimum, and that the latter is to be expected between March, 1954 and April, 1955.

551.594:621.317.72 1061

The Agrimeter for Continuous Recording of the Atmospheric Electric Field—J. A. Chalmers. (*Jour. Atmos. Terr. Phys.*, vol. 4, pp. 124-128; Oct., 1953.) Description of an instrument based on measurement of the "bound" charge on a portion of the earth's surface.

551.594.221 1062

The Pilot Streamer in Lightning and the Long Spark—B. F. J. Schonland. (*Proc. Roy. Soc. A*, vol. 220, pp. 25-38; Oct. 22, 1953.)

551.594.221:621.396.969.029.63 1063

The Study of Lightning Streamers with 50 cm Radar—F. J. Hewitt. (*Proc. Phys. Soc.*, vol. 66, pp. 895-897; Oct. 1, 1953.) Radar

echoes were observed during the whole period between the successive strokes in a lightning flash. Some components of these echoes appear to be associated with the processes leading up to the next stroke. Photographic cross-trace records of the stroke, at its commencement and 12 ms later, are reproduced and discussed.

551.594.6 1064

Methods of Synchronizing the Observations of a "Sferics" Network—A. L. Maidens. (*Met. Mag.*, (London), vol. 82, pp. 267-270; Sept., 1953.) Methods in use in the British network are described.

LOCATION AND AIDS TO NAVIGATION

621.396:551.594.6 1065

The Reception of Atmospherics at High Frequencies—F. Horne. (*Jour. Atmos. Terr. Phys.*, vol. 4, pp. 129-140; Oct., 1953.) Report on hf atmospheric-noise observations made at a single point (Teddington) with a view to assessing the practical possibility of basing estimation of source distances on them. Atmospherics were recorded simultaneously at two frequencies in the upper part of the hf band, and the source identity was checked from crdf data. Observations were expected to, and generally did, exhibit the following features: (a) reception at both frequencies from sources within ground-wave range; (b) no reception when the observation station lies in the skip zone for both frequencies; (c) reception on either the lower frequency or both frequencies, according as the observation station lies beyond the skip zone either for the lower frequency or for both frequencies. Difficulties of the method and results achieved are discussed.

621.396.96 1066

Theoretical Performance of Airborne Moving Target Indicators—F. R. Dickey, Jr. (*Trans. I.R.E.*, no. PGAE-8, pp. 12-23; June, 1953.) Fluctuations in the strength of echoes from fixed objects, due to the movement of the antenna, are considered and simple formulae developed to facilitate ground clutter attenuation calculations. The expression for the ratio of mean-square voltage change between two successive signals received from the ground to the mean-square signal voltage is the sum of four terms, one involving rotation, and the other three the displacement components. Each term is developed in a power series, three different beam shapes being taken into account.

621.396.96:621.396.677.859 1067

Designing Radomes for Supersonic Speeds—S. S. Oleesky. (*Electronics*, vol. 27, pp. 130-135; Jan., 1954.) Designs which will not attenuate or distort the radar beam are discussed.

621.396.963.325 1068

A High-Definition General-Purpose Radar—J. W. Jenkins, J. H. Evans, G. A. G. Wallace, and D. Chambers. (*Jour. Brit. IRE*, vol. 14, pp. 5-21; Jan., 1954. Discussion pp. 21-23.23.) A detailed description is given of equipment for operation in the 3-cm waveband; it is compact enough to be mobile, and can be used with only minor modifications for local aircraft control, airfield surface-movement control, harbor control, etc. Variable pulse width and automatically centering timebase are used. The paraboloid antenna reflector is moulded from a plastic of good dimensional stability. Ppi display is given on two 15-inch tubes.

621.396.969 1069

Some Possible Reductions in Gust Loads through Use of Radar in Transport Airplanes—H. B. Tolofson. (*Bull. Amer. Met. Soc.*, vol. 34, pp. 187-191; May, 1953.) Analysis of turbulence measurements made in different weather conditions indicates that a 10 per cent reduction of the magnitude of the largest gust loads might be achieved, but that little if any reduction of loads due to the more numerous weak gusts is to be expected from the use of airborne radar to detect storm areas. Passenger comfort could be appreciably increased. The use of

contour radar is desirable for selecting the smoothest path through storm areas that cannot be avoided.

MATERIALS AND SUBSIDIARY TECHNIQUES

535.371 1070

Fluorescence, Phosphorescence, and Photo-stimulation of NaCl(AgCl) with High-Energy Irradiation—M. Furst and H. Kallmann. (*Phys. Rev.*, vol. 91, pp. 1356-1367; Sept. 13, 1953.)

537.224 1071

Studies of the Heterocharges of Electrets—S. Wikström. (*Ericsson Tech.*, vol. 9, pp. 225-234; 1953.) Report of investigations of the dependence of the charging and discharging rate on temperature, the influence of a dc field at room temperature on a prepared electret, the influence of pressure during charging and discharging, and the influence of polarization on the capacitance and loss angle.

537.226:[546.48.882.5 + 546.817.882.5 1072

Dielectric Properties and Phase Transitions of $Cd_2Nb_2O_7$ and $Pb_2Nb_2O_7$ —G. Shuirane and R. Pepinsky. (*Phys. Rev.*, vol. 92, p. 504; Oct. 15, 1953.) Measurements were made at temperatures down to 40 degrees K; at a frequency of 10 kc and a field strength of 5 v/cm. The dielectric constant of cadmium niobate, which is 310 at room temperature, rises to a maximum of 1200 at 185 degrees K.; the Curie point. The corresponding constants for lead niobate are 185 and 360 (at 14 degrees K.) respectively. Ferroelectric-type hysteresis and a dielectric constant anomaly at 85 degrees K. were observed in the former material only.

537.226:[546.48.882.5 + 546.817.882.5 1073

Low-Temperature Dielectric Properties of Cadmium and Lead Niobates—J. K. Hulm. (*Phys. Rev.*, vol. 92, pp. 504-505; Oct. 15, 1953.) The results of measurements at temperatures down to 1.2 degrees K., at 1 kc and 10v/cm, are similar to those reported by Shuirane and Pepinsky (1072 above).

537.311.1 1074

Changes in the Electrical, Thermal, and Thermo-electrical Properties of Monovalent Metals by Lattice Distortions—A. W. Saenz. (*Phys. Rev.*, vol. 91, pp. 1142-1151; Sept. 1, 1953.) A transport equation is derived for the distribution of conduction electrons in monovalent metals with static lattice distortions, simple assumptions regarding interaction energy being made. Using an iteration method, and considering temperatures very much higher than the Debye temperature of the lattice, a set of integral equations is obtained and solved explicitly. General expressions are found for the resistivity, thermal conductivity and absolute thermoelectric power tensors and are applied to specific calculations for a metal having an array of parallel positive-negative edge dislocations.

537.311.33:538.632 1075

Current Carrier Lifetimes Deduced from Hall Coefficient and Resistivity Measurements—L. P. Hunter, E. J. Huibregtse, and R. L. Anderson. (*Phys. Rev.*, vol. 91, pp. 1315-1320; Sept. 15, 1953.) A method for determining the lifetime of charge carriers in semiconductors, based on theory presented by Landauer and Swanson (165 of January), gives results in reasonable agreement with those obtained on the same samples by injection methods.

537.311.33:546.23 1076

Anisotropic Resistivities of Selenium Crystals at High Frequencies—H. W. Henkels and J. Maczuk. (*Phys. Rev.*, vol. 91, pp. 1562-1563; Sept. 15, 1953.) Some measurements are reported; results are compared with values obtained previously.

537.311.33:546.23 1077

The Structure of Amorphous Selenium—H.

Richter, W. Kulcke and H. Specht. (*Z. Naturf.*, vol. 7a, pp. 511-532; Aug., 1952.) A study of the amorphous material, prepared in various ways, and of its transition to the crystalline state.

537.311.33:546.26-1 1078

The Electrical Resistance of Graphite at Low Temperatures—J. M. Reynolds, H. W. Hemstreet, and T. E. Leinhardt. (*Phys. Rev.*, vol. 91, pp. 1152-1155; Sept. 1, 1953.) The resistance of large-crystal natural graphite increases with increasing temperatures from 1.35 degrees K. to room temperature. That of polycrystalline graphite decreases over practically the whole of this range; at 5 degrees K. it is nearly independent of temperature.

537.311.33:[546.28+546.289] 1079

Electron Multiplication in Silicon and Germanium—K. G. McKay and K. B. McAfee. (*Phys. Rev.*, vol. 91, pp. 1079-1084; Sept. 1, 1953.) "Electron multiplication in silicon and germanium has been studied in the high fields of wide *p-n* junctions for voltages in the pre-breakdown region. Multiplication factors as high as eighteen have been observed at room temperature. Carriers injected by light, alpha particles, or thermal-generation are multiplied in the same manner. The time required for the multiplication process is less than 2×10^{-8} second. Approximately equal multiplication factors are obtained for injected electrons and injected holes. The multiplication increases rapidly as 'breakdown voltage' is approached. The data are well represented by ionization rates computed by conventional avalanche theory. In very narrow junctions, no observable multiplication occurs before Zener emission sets in, as previously reported. It is incidentally determined that the efficiency of ionization by alpha particles bombarding silicon is 3.6 ± 0.3 electron volts per electron-hole pair produced."

537.311.33:546.28 1080

Paramagnetic Resonance in N- and P-Type Silicon—F. K. Willenbrock and N. Bloembergen. (*Phys. Rev.*, vol. 91, p. 1281; Sept. 1, 1953.) Experiments were performed at 9 kmc at 78 degrees K. The absorption signal was roughly proportional to impurity concentration

537.311.33:546.289 1081

Absorption of Infrared Light by Free Carriers in Germanium—II. B. Briggs and R. C. Fletcher. (*Phys. Rev.*, vol. 91, pp. 1342-1346; Sept. 15, 1953.) Measurements were made of the radiation absorbed when free carriers were injected across a *p-n* junction; the absorption was proportional to the carrier concentration. The absorption/wavelength curve exhibits the maxima previously observed in ordinary *p*-type Ge; the positions of these maxima depend on temperature. An explanation of the observations based on degenerate energy bands is advanced.

537.311.33:546.289 1082

Infrared Absorption in P-Type Germanium—W. Kaiser, R. J. Collins and H. Y. Fan. (*Phys. Rev.*, vol. 91, pp. 1380-1381; Sept. 15, 1953.) Measurements made at temperatures down to 5 degrees K. indicate that the absorption coefficient is proportional to the hole concentration. There is a strong absorption band above 10μ , caused by excitations within the filled band due to the presence of holes, and two weaker bands at shorter wavelengths, one of which disappears at low temperatures.

537.311.33:546.289 1083

Optical Studies of Injected Carriers: Part 1—Infrared Absorption in Germanium—R. Newman. (*Phys. Rev.*, vol. 91, pp. 1311-1312; Sept. 15, 1953.) Measurements were made of the amount of radiation transmitted through a *p-n* junction Ge diode into which carriers were injected in pulses. The results indicate that for injection into low-resistivity material (*p*-type) the injection current is proportional to the

injected carrier density, while for injection into high-resistivity material (*n*-type) there is a departure from proportionality.

537.311.33:546.289 1084

Optical Studies of Injected Carriers: Part 2—Recombination Radiation in Germanium—R. Newman. (*Phys. Rev.*, vol. 91, pp. 1313-1314; Sept. 15, 1953.) Measurements were made of the radiation produced by direct recombination of electrons and holes in *p-n* junction Ge diodes into which carriers were injected in pulses. The observed spectral distribution is in fair agreement with theory. The intensity of radiation is proportional to the injection current for both high- and low-resistivity material. Polarization of the radiation at oblique angles of emergence was observed.

537.311.33:546.289 1085

Surface Recombination in Germanium—W. N. Reynolds. (*Proc. Phys. Soc.*, vol. 66, pp. 899-901; Oct. 1, 1953.) The variation of the surface recombination velocity of injected minority carriers with temperature was determined for five different surfaces. The absolute values were found to be very sensitive to changes in the etching procedure.

537.311.33:546.289 1086

Electrical Conductivity of Mechanically Disturbed Germanium Surfaces—E. N. Clarke and R. L. Hopkins. (*Phys. Rev.*, vol. 91, pp. 1566-1567; Sept. 15, 1953.) Experiments indicate that the effect of polishing, sandblasting, etc., is to produce a surface layer of relatively high conductivity.

537.311.33:546.289 1087

Microwave Observation of the Collision Frequency of Holes in Germanium—T. S. Benedict. (*Phys. Rev.*, vol. 91, pp. 1565-1566; Sept. 15, 1953.) Using the technique previously described [2330 of 1953 (Benedict and Shockley)], measurements were made of the permittivity and conductivity of *p*-type Ge in order to determine the effective mass of the holes and the relaxation time. Results are shown graphically and discussed.

537.311.33:546.289 1088

The Conductivity of Germanium at 2.4×10^{10} c/s—Y. Klinger. (*Phys. Rev.*, vol. 92, pp. 509-510; Oct. 15, 1953.) The conductivity of a highly purified Ge sample over the temperature range 0-100 degrees C. was determined from the results of permittivity and loss-tangent measurements. At 100 degrees C. the hf conductivity is approximately half the dc conductivity; the hf and dc activation energies are 0.60 and 0.775 eV respectively.

537.311.33:546.289 1089

Electrical Properties of Gold-Germanium Alloys—W. C. Dunlap, Jr. (*Phys. Rev.*, vol. 91, p. 1282; Sept. 1, 1953.) Au acts as an acceptor capable of taking up electrons at two distinct energy levels, the first 0.15 eV above the filled band, the second 0.2 eV below the conduction band. At 77 degrees K. resistivities up to $5 \times 10^7 \Omega \cdot \text{cm}$ have been obtained.

537.311.33:546.289 1090

The Atomic Heat of Germanium below 4 degrees K—P. H. Keesom and N. Perlman. (*Phys. Rev.*, vol. 91, pp. 1347-1353; Sept. 15, 1953.)

537.311.33:546.289:537.323 1091

Measurement of the Thermoelectric Power of Germanium at Temperatures above 78 degrees K—A. E. Middleton and W. W. Scanlon. (*Phys. Rev.*, vol. 92, pp. 219-226; Oct. 15, 1953.) An experimental investigation on pure and impure Ge over the temperature range 78 degrees to 925 degrees K. At low temperatures, where conduction is due to impurity-introduced carriers, the sign of the thermoelectric power is the same as that of the Hall coefficient, the magnitudes of the thermoelectric power, resistivity and Hall coefficient increase with a

decrease in the impurity content. With rising temperature the magnitude of the thermoelectric power increases and passes through a maximum, the value for *p*-type material subsequently passing through zero. The results are presented graphically.

537.311.33:546.289:537.323 1092

Theory of Thermoelectric Power in Semiconductors with Applications to Germanium—V. A. Johnson and K. Lark-Horovitz. (*Phys. Rev.*, vol. 92, pp. 226-232; Oct. 15, 1953.) An expression for the thermoelectric power is obtained in terms of the Fermi level, width of forbidden band, temperature, ratio of electron to hole mobility, and effective electron and hole masses. For the impurity range, the formula can be simplified to involve only the Hall coefficient and the temperature. Consideration is given to the case when charge carriage by both holes and electrons must be taken into account. The results are compared with those obtained experimentally by Middleton and Scanlon (1091 above).

537.311.33:546.289:537.323 1093

Thermoelectric Power of Germanium below Room Temperature—H. P. R. Frederikse. (*Phys. Rev.*, vol. 92, pp. 248-252; Oct. 15, 1953.) Measurements were made on *n*-type Ge samples in the range 10 degrees to 300 degrees K. The temperature dependence at temperatures above 200 degrees K. is in good agreement with conventional theory but below this temperature the thermoelectric power rises sharply above the predicted value and reaches a maximum of several millivolts per degree (with Cu) at 15 degrees K. This deviation is due to the disturbance of the phonon equilibrium.

537.311.33:546.289:539.3 1094

Germanium under Ultrasonic Stress: Part 1—Anelastic Effects—G. S. Baker, L. M. Slifkin, and J. W. Marx. (*Jour. Appl. Phys.*, vol. 24, p. 1331; Oct., 1953.) Five samples of 30- $\Omega \cdot \text{cm}$ single crystals, in the form of right prisms with the major axis along the [100] direction, were driven in fundamental longitudinal vibration at 111 kc. Young's modulus E_{100} was measured at temperatures between 26 degrees and 876 degrees C. Anomalies were observed in two samples.

537.311.33:546.289:539.3 1095

Germanium under Ultrasonic Stress: Part 2—Dynamic Yield Point—G. S. Baker, L. M. Slifkin, and J. W. Marx. (*Jour. Appl. Phys.*, vol. 24, pp. 1331-1332; Oct., 1953.) The transient and the residual effects on the yield stress were investigated at temperatures up to 614 degrees C. for mechanically normal Ge specimens of conductivity $\sim 20 \Omega \cdot \text{cm}$. but with the major axis parallel to the [111] direction, and driven in fundamental longitudinal vibration at ~ 37 kc.

537.311.33:546.472.21 1096

Some Electrical and Optical Properties of Synthetic Single Crystals of Zinc Sulfide—W. V. Piper. (*Phys. Rev.*, vol. 92 pp. 23-27; Oct. 1, 1953.) A report of measurements of hexagonal ZnS (wurtzite) to determine the energy band gap.

537.311.33:546.472.21 1097

Perfect Crystals of Zinc Sulfide—W. V. Piper and W. L. Roth. (*Phys. Rev.*, vol. 92, p. 503; Oct. 15, 1953.) Differences between the properties of ZnS crystals grown by sublimation in an atmosphere of hydrogen and those of ordinary ZnS crystals are discussed.

537.311.33:546.682.86 1098

Optical Properties of Indium Antimonide—N. Tanenbaum and H. B. Briggs. (*Phys. Rev.*, vol. 91, pp. 1561-1562; Sept. 15, 1953.) Measurements indicate that the intrinsic limit of absorption lies at 7μ , and that the presence of Ni as an impurity is at least partly responsible for anomalous transmission in the range 3-7 μ .

- 537.311.33:546.86.48 1099
Impurity and Intrinsic Semiconduction of Intermetallic Compounds: Part 2—E. Justi and G. Lautz. (*Z. Naturf.*, vol. 7a, pp. 602-613; Sept., 1952.) An experimental investigation is made of the temperature dependence of the electrical conductivity, the variation of resistivity in a magnetic field, the differential thermoelectric power and the rectifying properties of CdSb. The results show that, as predicted by the theory presented in part 1 (3619 of 1953), CdSb is an intrinsic semiconductor in the stoichiometric state, and can be turned into an impurity semiconductor by departure from stoichiometric composition or by adding other metals.
- 537.311.33:621.396.822 1100
A Possible Mechanism for 1/f Noise Generation in Semiconductor Filaments—L. Bess. (*Phys. Rev.*, vol. 91, p. 1569; Sept. 15, 1953.) Analysis is presented based on the Brownian motion of a surface atom displaced from its equilibrium position.
- 538.221 1101
Oriental Superstructures—L. Néel. (*Compt. Rend. Acad. Sci.*, (Paris), vol. 237, pp. 1613-1616; Dec. 21, 1953.) Discussion of phenomena induced in solid solutions of ferromagnetic materials with crystals of cubic structure, when cooled so as to retain permanent anisotropy. Magnetic anisotropy of various ferromagnetic alloys is attributed to this phenomenon.
- 538.221 1102
Definition of a Ferromagnetic State with Maximum Stability—J. Creusot and A. Langevin. (*Compt. Rend. Acad. Sci.*, (Paris), vol. 237, pp. 1499-1500; Dec. 9, 1953.) B/H measurements were made on various materials with the object of finding the most stable equilibrium state corresponding to each value of H, so that B is a two-valued function of H. Superposed on the magnetizing field H is an alternating field whose strength is varied continuously down to zero; B is then measured. The formula obtained for B as a function of H is in agreement with that proposed by P. Langevin in 1911.
- 538.221 1103
Surface Anisotropy of Ferromagnetic Substances—L. Néel. (*Compt. Rend. Acad. Sci.*, (Paris), vol. 237, pp. 1468-1470; Dec. 9, 1953.)
- 538.221 1104
Study of the Ferromagnetism of Multicrystal and Single-Crystal Cementite [Fe₃C]—P. Blum and R. Pauthenet. (*Compt. Rend. Acad. Sci.*, (Paris), vol. 237, pp. 1501-1502; Dec. 9, 1953.) Measurements over the temperature range 20.4 degrees to 500 degrees K. are reported.
- 538.221 1105
Theory of Saturation Magnetization in Binary Ferromagnetic Alloys—H. Statz. (*Z. Naturf.*, vol. 7a, pp. 506-511; Aug., 1952.) The electron structure of the alloys Ni-Cu, Ni-Zn, Ni-Co, Fe-Ni, Fe-Co, Fe-V and Fe-Cr is investigated in relation to the saturation magnetization.
- 538.221 1106
Variation of the Magnetic Permeability of a Mild Steel subjected to a Periodic Stress—G. Vidal and P. Lanusse. (*Compt. Rend. Acad. Sci.*, (Paris), vol. 237, pp. 1213-1215; Nov. 16, 1953.) Continuation of work noted previously (446 of February).
- 538.221:621.318.124 1107
Dielectric Behaviour of Granular Semiconducting Aggregates, with Special Reference to Some Magnesium Ferrites—A. Fairweather and E. J. Frost. (*Proc. IEE*, part IIA, vol. 100, no. 3, pp. 15-22; 1953.) "Aggregated granular semiconductors can display high permittivities and dispersion effects which vary with temperature and voltage. This behavior need not be characteristic of the granule material: it can be a consequence of its conductivity and of a particular kind of inhomogeneity of the aggregate arising from the contact structure of the intergranular boundaries. The dielectric properties of certain sintered magnesium ferrites can be accounted for in this way."
- 538.221:621.318.124:538.66 1108
On the Magnetization of Magnesium Ferrite—N. Sakamoto, T. Asahi, and S. Miyahara. (*Jour. Phys. Soc.*, (Japan), vol. 8, pp. 677-678; Sept./Oct., 1953.) An experimental investigation of the effect of heat treatment is reported. The results are summarized in a table showing the rates of cooling from 100 degrees C. and the saturation magnetization per mol at room temperature. A table is also given of the characteristic temperatures, derived from Néel's chemical-equilibrium condition (3159 of 1949), corresponding to the various quenching temperatures.
- 538.221:621.318.134 1109
Influence of the Ionic Diameters of the Rare Earths on the Ferromagnetic Properties of their Ferrites—G. Guiot-Guillain. (*Compt. Rend. Acad. Sci.*, (Paris), vol. 237, pp. 1654-1656; Dec. 21, 1953.) The ferromagnetic Curie points for three groups of rare-earth ferrites exhibiting distinct properties are shown to be related to the ionic diameters by simple expressions. An explanation is advanced of the observations of two Curie points in one group.
- 538.23 1110
Some New Relations connecting the Magnitudes of Losses with the Coercive Force—N. S. Akulov and T. A. Elkina. (*Compt. Rend. Acad. Sci.*, (U.R.S.S.), vol. 83, pp. 377-379; March 21, 1952. In Russian.) The irreversible magnetization (retentivity) and the losses in weak fields can be calculated by assuming ferromagnetic materials to consist of elementary regions with rectangular hysteresis loops [Preisach (3691 of 1935)], the coercive force varying from region to region. The experimental and calculated losses for several materials are in good agreement.
- 538.632:[546.817.241+546.331.31 1111
Sensitive Hall Measurements on NaCl and on Photoconductive PbTe—J. L. Levy. (*Phys. Rev.*, vol. 92, pp. 215-218; Oct. 15, 1953.) Measurements were made on NaCl over the temperature range 650-795 degrees C. and on PbTe at 190 degrees C. and at 30 degrees C. Because of the high noise level, only an upper limit for the Hall mobility could be determined for NaCl. The results for PbTe support Simpson's theory (861 of 1952) that an increase in photoconductivity is primarily due to an increase in carrier density and only secondarily to a change of mobility.
- 539.153:546.281.26 1112
Energy of Trapped Electrons in Ionic Solids—K. Lehovec. (*Phys. Rev.*, vol. 92, pp. 253-258; Oct. 15, 1953.) The energy of an electron localized in a crystal at an impurity carrying multiple positive charges is calculated. The results are applied to a tentative interpretation of activation energies of SiC crystals observed by Busch (745 of 1947).
- 546.26:539.215.3:537.311.4 1113
The Properties of Carbon Contacts—R. O. Grisdale. (*Jour. Appl. Phys.*, vol. 24, pp. 1288-1296; Oct., 1953.) The correlation between the contact properties and the crystallographic structure of the surfaces is relatively little influenced by the intercrystal boundaries. The contact properties are determined by those of the small number of crystals in contact. The physical properties of these crystals are studied.
- 546.431-31 1114
Oxygen Vacancies in Barium Oxide—R. L. Sproull, R. S. Bever, and G. Libowitz. (*Phys. Rev.*, vol. 92, pp. 77-80; Oct. 1, 1953.) The diffusion of the blue coloration produced when BaO crystals are heated in certain metal vapours (1115 below) was measured at temperatures between 800 degrees and 1300 degrees C. Comparison of the results with those obtained by Redington (432 of 1953) indicates that the diffusion process associated with the coloration does not involve the transport of Ba, and that the principal lattice defects in BaO with excess are O vacancies.
- 546.431-31:[535.215+535.343.2 1115
Optical Absorption and Photoconduction in the Visible and Near Infrared in Single Crystals of BaO—W. C. Dash. (*Phys. Rev.*, vol. 92, pp. 68-76; Oct. 1, 1953.) Optical-absorption measurements indicate the presence of absorption bands at 0.8 and 1.4 ev, induced by ultraviolet or X-ray irradiation at about -160 degrees C. These bands are enhanced about fivefold on heating a crystal in air to about 1600 degrees C. and quenching. Absorption curves for crystals heated in Ba, Al, Mg or Ca vapor all exhibit a maximum at 2 ev, which is attributed to interstitial Ba or O vacancies. Photoconduction studies indicate the presence of energy levels at 2 and 2.6 ev as well as those at 0.8 and 1.4 ev.
- 546.431.824-31 1116
Temperature Changes of Single Crystals of BaTiO₃—I. N. Belyaev, N. S. Novosil'tsev, E. G. Fesenko, and A. L. Khodakov. (*Compt. Rend. Acad. Sci.*, (U.R.S.S.), vol. 83, pp. 675-676; April 11, 1952. In Russian.) The temperature dependence of the dielectric constant and of the crystal cell parameters was determined for two crystals prepared from a solution and one by double decomposition. The results are shown graphically.
- 546.431.824-31:537.226.33 1117
Time Effects in the Hysteresis Loop of Polycrystalline Barium Titanate—M. McQuarrie. (*Jour. Appl. Phys.*, vol. 24, pp. 1334-1335; Oct., 1953.) The maximum and the remanent polarization decrease with aging by approximately the same amount until the loop shows a constriction at the center. This effect can be partially annulled by application of a strong alternating field, and completely annulled by heating to above the Curie temperature.
- 621.383.49:546.482.21:535.215.5 1118
Photoresistivity and Photoactivation of CdS Single Crystals—V. E. Lashkarev, V. S. Medvedev, A. I. Skopenko, G. A. Fedorus, and M. K. Sheinkman. (*Compt. Rend. Acad. Sci.*, (U.R.S.S.), vol. 86, pp. 905-907; Oct. 11, 1952. In Russian.) The increase of light sensitivity due to background illumination was investigated. Graphs are shown of the variation in sensitivity (photoelectric-current/quantum) with the wavelengths of the background illumination λ_p and impulse illumination λ_e , in the visible-light range. The spectral sensitivity in the 2100-4000-Å range is also shown.
- 546.561.221 1119
On the Electrical Conductivity of Cuprous Sulfide: a Diffusion Theory—I. Yokota. (*Jour. Phys. Soc. (Japan)*, vol. 8, pp. 595-602; Sept./Oct., 1953.) Cuprous sulphide, a p-type semiconductor, exhibits mixed electronic and ionic conduction in the 110-470 degrees C. β phase. A theory of conduction is developed which gives values for the potential distribution in the material in good agreement with values observed by Miyatani and Suzuki (1120 below), for both transient and steady-state conditions. The temperature dependence of the ionic and hole conductivities and of the mobility of vacant copper ion lattice points is shown graphically.
- 546.561.221 1120
On the Electric Conductivity of Cuprous Sulfide: Experiment—S. Miyatani and Y. Suzuki. (*Jour. Phys. Soc. (Japan)*, vol. 8, pp. 680-681; Sept./Oct., 1953.) Yokota's theory of

conduction (1119 above) is used to calculate the mobility and the concentration of lattice defects from the experimental results for β -phase cuprous sulphide.

546.817.831.4.03 + 546.817.824.03 1121
Ferroelectricity versus Antiferroelectricity in the Solid Solutions of $PbZrO_3$ —E. Sawaguchi. (*Jour. Phys. Soc. (Japan)*, vol. 8, pp. 615–629; Sept./Oct., 1953.) The phase diagram of the solid solutions was investigated by measuring the variations with temperature of the dielectric constant, thermal expansion, specific heat and lattice constants. In $Pb(Zr_{97}-Ti_3)O_3$, two antiferroelectric phases, one ferroelectric phase and one paraelectric phase were observed. The free energies in the four states are compared as functions of the temperature and the Ti ion concentration. The results are shown graphically.

548.0:539.378.3 1122
Some Predicted Effects of Temperature Gradients on Diffusion in Crystals—W. Shockley. (*Phys. Rev.*, vol. 91, pp. 1563–1564; Sept. 15, 1953.) Experiments are outlined by means of which it is possible to distinguish between diffusion due to interstitial atoms and diffusion due to vacancies.

621.315.61:061.3 1123
Symposium of Papers on Insulating Materials—(*Proc. IEE*, part IIA, vol. 100, pp. 1–308; 1953.) Full report of the proceedings at the symposium held in March, 1953, with index.

MATHEMATICS

517.9 1124
The Eigenvalues of $\nabla^2 u + \lambda u = 0$ when the Boundary Conditions are given on Semi-infinite Domains—D. S. Jones. (*Proc. Camb. Phil. Soc.*, vol. 49, part 4, pp. 668–684; Oct., 1953.) Investigation of an equation which represents the small oscillations of many physical systems.

MEASUREMENTS AND TEST GEAR

621.317:537.71(083.74) 1125
The Accuracy of Measurement of Electrical Standards—A. Felton. (*Proc. IEE*, part II, vol. 100, pp. 543–544; Oct., 1953.) Discussion on 1952 of 1952.

621.317:621.383.2 1126
The Photodiode—Deloffre, Pierre, and Roig. (*See* 1249.)

621.317.3:621.396.67.029.64 1127
Measurements on Aerials for Centimetre Waves—M. Bouix. (*Ann. Télécommun.*, vol. 8, pp. 314–326; Oct., 1953.) Methods are discussed for the measurement of (a) swr (to test the matching between antenna and feeder), (b) phase of primary radiators, (c) radiation patterns both for primary radiators and complete aerial systems, (d) gain. Equipment described includes transmitter and sensitive receiver for the radiation-pattern and gain measurements. Attention is drawn to special requirements as regards the terrain over which the tests are made.

621.317.3.029.63/.64 + 534.62 1128
A New Anechoic Chamber for Sound Waves and Short Electromagnetic Waves—Meyer, Kurtze, Severin, and Tamm. (*See* 942.)

621.317.31:621.375.2 1129
Measurement of Weak Electric Charges by means of Pulse Technique—Study of a Fast-Acting Pre-amplifier with High Input Impedance and Low Noise—H. Guillon. (*Onde élect.*, vol. 33, pp. 627–636; Nov., 1953.)

621.317.31:621.387.4 1130
Measurement of Weak Electric Charges by means of Pulse Technique— α -Radiation Spectrometry—G. Valladas. (*Onde élect.*, vol. 33, pp. 615–626; Nov., 1953.)

621.317.32:537.1 1131
The Static and Dynamic Measurement of Electromotive Forces—W. J. Poppelbaum. (*Helv. Phys. Acta*, vol. 26, pp. 489–498; Sept. 15, 1953. In French.) Generalization of Meixner's equation (*Ann. Phys., Lpz.*, vol. 35, p. 701; 1939.) Leads to a formulation including within its scope phenomena as varied as induction, thermoelectricity and the chemical processes in a cell. Consideration of the distinction between voltaic and galvanic potential difference results in a simple method of taking account of contact potential difference in static measurements.

621.717.335 1132
Precise Measurement of the Complex Dielectric Constants of Liquids by Voltage Resonance—C. Abgrall. (*Compt. Rend. Acad. Sci., (Paris)*, vol. 237, pp. 1650–1652; Dec. 21, 1953.) A substitution method is used in which either a standard capacitor or the cell containing the liquid is connected in an oscillatory circuit in series with a high impedance. Analysis of the system is based on a linear formulation, and the effect of the impedances of the connections is examined.

621.317.355.029.64 1133
Method for the Measurement of the Dielectric Constant of Gases at Ultrahigh Frequencies—A. Gozzini and E. Pollaco. (*Compt. Rend. Acad. Sci., (Paris)*, vol. 237, pp. 1497–1499; Dec. 9, 1953.) A klystron generator, operated at about 10 kmc, is frequency modulated between the limiting frequencies ν_0 and ν_1 by application of a sawtooth voltage to the repeller. Two cavities tuned to different frequencies between ν_0 and ν_1 are associated with the system, one of the cavities being filled with the gas under test. The dielectric constant is determined from the time interval between the instants when the two cavities resonate.

621.317.335.029.64 1134
Complementary Note on the Method of Measurement of the Dielectric Constant of Gases at U.H.F.—A. Gozzini and E. Pollaco. (*Compt. Rend. Acad. Sci., (Paris)*, vol. 237, pp. 1652–1654; Dec. 21, 1953.) A modification of the method previously described (1133 above) to give improved sensitivity is proposed.

621.317.335.3.029.65 1135
A Spectrometer for Millimetre Wavelengths—W. Culshaw. (*Proc. IEE*, part IIA, vol. 100, pp. 5–14; 1953. Discussion, pp. 54–60.) A free-space method is described for the measurement of permittivity at mm λ , using the microwave analogue of the optical spectrometer, horns with lenses taking the place of the optical collimator and telescope. The reflectivity of sheets of material is investigated at different angles of incidence for different polarizations; interference minima and Brewster angle are determined and accurate values of permittivity are hence deduced. The effects of dielectric loss and of diffraction are discussed. Results substantiating the theory are presented. An extension of the method to deal with liquids is described.

621.317.34.018.75:621.315.212 1136
Echo Meter with Very Short Pulse Duration for Investigation of Coaxial-Pair Television Cables—G. Comte, M. Boudier, and G. Thévenet. (*Câbles & Transm.*, vol. 7, pp. 263–269; July, 1953.) A description is given, with circuit details, of an instrument designed for production testing of television cables, with application for research at higher frequencies. Features of the equipment are the short pulse duration (0.02 μ s) and the use of distributed amplification in the echo amplifier to give a wide frequency band.

621.317.34.029.5/.6]:621.315.212 1137
Tests at Very High Frequencies on Production Lengths of Coaxial Cable—J. Lorrin. (*Câbles & Transm.*, vol. 7, pp. 218–241; July,

1953.) A null method of measurement is described for determination of propagation coefficient and characteristic impedance in production testing of coaxial cables. Measurement principles are based on transmission-line theory taking account of irregularities; this is dealt with in an appendix. Bridge balance is obtained by adjustment of both reactance and frequency, and the design of an oscillator/receiver unit with a single frequency control is discussed. Illustrated descriptions are given of two instruments. Results of measurements on cables of length 100–300 m are shown.

621.317.341.029.62/.65 1138
A.M. System measures Microwave Attenuation—J. Korewick. (*Electronics*, vol. 27, pp. 175–177; Jan., 1954.) See 803 of March.

621.317.35:621.3.018.78 1139
Measuring Non-linearity—D. C. Pressey. (*Wireless World*, vol. 60, pp. 60–62; Feb., 1954.) A simple method is presented which is supplementary to that described by Wigan (2383 of 1953) and which uses a frequency-insensitive element to perform the subtraction of the fundamental from the composite wave.

621.317.38.029.63 1140
Force on a Shorted Ring in a U.H.F. Field in a Coaxial Wavity—S. N. Kalra. (*Jour. Appl. Phys.*, vol. 24, pp. 1339–1340; Oct., 1953.) The change in potential energy of a metal ring, the dimensions of which are small compared with λ , is made the basis of power measurement. Accuracy for powers of a few watts is within ~ 1 per cent.

621.317.44 1141
Dynamic Measurements on Electromagnetic Devices—M. A. Logan. (*Bell. Sys. Tech. Jour.*, vol. 32, pp. 1413–1467; Nov., 1953.) An electronic timing system controlling mercury-contact relays is used to switch in the measuring instrument (e.g. fluxmeter) for a very short period only at a preselected instant of each cycle of operation of the device tested. The system and the circuits required for the dynamic measurement of magnetic flux, current, displacement and velocity response are described.

621.317.444 1142
A Small Sensitive Magnetometer—T. M. Palmer. (*Proc. IEE*, part II, vol. 100, pp. 545–550; Oct., 1953.) The measuring head contains a solenoid through which is passed a dc balancing out the field under test. A saturating current of frequency 5 kc is passed through a fine mumetal wire within the solenoid, causing its effective longitudinal permeability to alternate, so that a field along the wire produces an alternating emf in the solenoid; this emf serves as an indication of the field. A change of 2×10^{-5} oersted can be detected. The measurement range is limited to about 50 oersted due to the heating of the solenoid.

621.317.7 1143
Device for Measurement of the Time Constants of Indicating Instruments—J. Mey and H. Thibert. (*Ann. Télécommun.*, vol. 8, pp. 327–334; Oct., 1953.) The time constant for indication, the time for restoration to zero, and the "integrating" time are considered, particularly in relation to volume and modulation meters for telephone testing. Apparatus devised for measuring these time constants comprises an electro-optical system for marking the passage of a galvanometer needle through a pre-determined position, an electronic chronometer, and a "chronotome" relay.

621.317.7.088 1144
Performance Limits in Electrical Instruments—A. H. M. Arnold. (*Proc. IEE*, part II, vol. 100, pp. 543–544; Oct., 1953.) Discussion on 1971 of 1952.

621.317.714.024 1145
Non-Contact D.C. Ammeter—W. H. Bailey. (*Elect. Rev.*, vol. 153, pp. 397–400; Aug. 21,

1953.) Description of a device which permits remote indication and recording of the current in a cable.

621.317.729 1146

The Accurate Mapping of Electric Fields in an Electrolytic Tank—K. F. Sender and J. G. Yates. (*Proc. IEE*, part II, vol. 100, pp. 569-570; Oct., 1953.) Discussion on 2739 of 1953.

621.317.756+621.317.77 1147

A Harmonic-Response-Testing Equipment for Linear Systems—D. O. Burns and C. W. Cooper. (*Proc. IEE*, part II, vol. 100, p. 467; Oct., 1953.) Discussion on 3374 of 1953.

621.317.76+531.771]:621.387 1148

A High-Speed Precision Tachometer—Bland and Cooper. (See 1153.)

621.373.43:621.317.3 1149

High-Voltage Sawtooth and Rectangular-Wave Pulse Generator—W. D. Edwards. (*Electronic Eng.*, vol. 26, pp. 36-39; Jan., 1954.) Descriptions are given of a square-wave generator giving an output of 0-20 kv with pulse duration continuously variable between 0.05 and 80 μ s, and of a sawtooth generator giving a peak output of 18 kv with rise time of 15 μ s-10ms. The generators are specially designed for measurements of dielectric strength.

621.397.5:535.623].001.4 1150

Methods of Verifying Adherence to the N.T.S.C. Color Signal Specifications—A. C. Luther, Jr. (*Proc. I.R.E.*, vol. 42, pp. 235-240; Jan., 1954.) The composition of the color signal is determined by measuring the amplitudes and relative phases of a group of bar signals corresponding to saturated primary colors and their complements. The use of a simple demodulator for accurate measurement of phase at the 3.58-mc subcarrier frequency is described.

621.397.5:535.623].001.4 1151

A Versatile Approach to the Measurement of Amplitude Distortion in Color Television—J. A. Bauer. (*Proc. I.R.E.*, vol. 42, pp. 240-246; Jan., 1954.) The importance of system linearity for maintaining the selected value of gamma is emphasized, and an instrument developed for checking the degree of nonlinearity is described.

621.397.5:535.623].001.4 1152

Test Instruments for Color Television—W. C. Morrison, K. Karstad, and W. L. Behrend. (*Proc. I.R.E.*, vol. 42, pp. 247-258; Jan., 1954.) Equipment for use in measuring frequency response, differential gain and differential phase, and sound-to-picture frequency separation is described.

OTHER APPLICATIONS OF RADIO AND ELECTRONICS

531.771+621.317.76]:621.387 1153

A High-Speed Precision Tachometer—W. R. Bland and B. J. Cooper. (*Electronic Eng.*, vol. 26, pp. 2-8; Jan., 1954.) An integrating-type electronic tachometer with ranges of 0-8,000 and 10-80,000 rpm and a reading accuracy within 0.01 per cent uses cold-cathode glow-discharge tubes to give a visual display. The instrument can be used with a variety of pickups, and can also be used as a frequency meter.

551.508.1:621.396.91 1154

The Ground Equipment for the F-Type Radioisonde—B. B. Huddar, K. Nagarajan, N. C. Dhar, and S. P. Venkiteswaran. (*Indian Jour. Met. Geophys.*, vol. 4, pp. 347-352; Oct., 1953.) Equipment in use at Poona is described; the receiver is of superregenerative type, and the recorder is of moving-coil type.

621-52:621.389 1155

An Electronic Process Controller—J. R. Boundy and S. A. Bergen. (*Proc. IEE*, part II, vol. 100, pp. 561-562; Oct., 1953.) Discussion on 1386 of 1952.

621.316.722:621.383.27:621.387.464 1156

Device for the Stabilization of Photomultipliers—R. Ascoli. (*Nuovo Cim.*, vol. 9, pp. 615-617; July 1, 1952.) A stabilizer for scintillation counters makes use of the constancy of the emission from a radioactive source.

621.385.832/.833]:538.691 1157

Image Distortion due to Pole-Piece Asymmetry in Electron Lenses—W. Glaser and P. Schiske. (*Z. angew. Phys.*, vol. 5, pp. 329-339; Sept., 1953.)

621.385.833 1158

Electron-Optical Properties of Electrostatic Lenses: Part 2—W. Lippert and W. Pohlitz. (*Optik, Stuttgart*, vol. 10, pp. 447-454; 1953.) Further results are given of the work on unipotential lenses previously noted (795 of 1953).

621.385.833 1159

Trajectories in the Symmetrical Electron Lens—L. Jacob and J. R. Shah. (*Jour. Appl. Phys.*, vol. 24, pp. 1261-1266; Oct., 1953.) Numerical evaluation of trajectories in a strong unipotential lens. See also 1396 of 1952 (Shah and Jacob).

621.387.464 1160

The Efficiency of the Anthracene Scintillation Counter—D. K. Butt. (*Proc. Phys. Soc.*, vol. 66, pp. 940-944; Oct. 1, 1953.) Investigation of a counter having a crystal about 1 cm²×2 mm placed on the end of an uncooled E.M.I. Type-5060 photomultiplier tube.

621.387.464:550.835 1161

A Scintillation Counter for Radioactivity Prospecting—D. H. Pierson and J. Pickup. (*Jour. Brit. IRE*, vol. 14, pp. 25-32; Jan., 1954.) A simple and compact arrangement is obtained by using a scintillation counter in conjunction with a cold-cathode tube in the counting-rate meter circuit and a specially designed recording microammeter.

PROPAGATION OF WAVES

538.566+621.372.2 1162

The Effect of the Radiation Condition in the case of Complex Wave Number, and its Significance in the Problem of Surface Waves—A. Haug. (*Z. Naturf.*, vol. 7a, pp. 501-505; Aug., 1952.) It is shown that Sommerfeld's radiation condition (i.e. that the wave vanishes at infinity) guarantees the uniqueness of the solutions of the wave equation $\Delta u + k^2 u = 0$ in the whole space, not only for real but also for complex values of the wave number k . It follows from the treatment presented that the existence of Sommerfeld's surface wave is not inconsistent with the radiation condition.

538.566+621.372.2]:621.3.012 1163

N_{ex} Chart for the Solution of Transmission-Line and Polarization Problems—Deschamps. (See 965.)

621.396.11 1164

Nonstandard Radio Propagation—P. G. Forsyth. (*Nature, (London)*, vol. 172, p. 966; Nov. 21, 1953.) Brief report of long-range reception observed at Ottawa on frequencies between 60 and 72 mc.

621.396.11:551.5 1165

Ultra-Short-Wave Field Strength in a Ground-Based Radio Duct—R. S. Unwin. (*Nature, (London)*, vol. 172, pp. 856-857; Nov. 7, 1953.) Discussion of field-strength observations at λ 3 cm, 9 cm, and 60 cm, made at various heights over the sea under widely differing superrefractive conditions. A rough estimate can be made of the maximum field strength in the duct at distances up to 100 km from the transmitter, if the average width of the ground-based duct can be assumed from meteorological data to be greater than a critical value for the particular wavelength. See also 1471 of 1953 (Hay and Unwin) and back references.

621.396.11:551.510.535 1166

Coupling and Conditions for Reflection of

the Ordinary and Extraordinary Electromagnetic Waves in an Inhomogeneous Anisotropic Plasma (Ionosphere)—R. Jancel and T. Kahan. (*Compt. Rend. Acad. Sci., (Paris)*, vol. 237, pp. 1657-1659; Dec. 21, 1953.) The propagation equations are solved, taking the plasma as characterized by a dielectric tensor which does not vary with height except insofar as the electron concentration varies, and taking account of the earth's magnetic field. The conditions giving rise to triple splitting are established.

621.396.11:551.510.535 1167

A New Phenomenon of Interaction between Waves and Free Electrons subjected to the Terrestrial Magnetic Field—M. Cutolo. (*Nuovo Cim.*, vol. 9, pp. 687-698; Aug. 1, 1952.) Experiments indicate that modulated waves of carrier frequency equal to the frequency of rotation of free electrons suffer appreciable demodulation in traversing the ionosphere, due to the action of the terrestrial magnetic field. The magnitude of the effect increases with the modulation frequency. Various names, eg self-demodulation, are suggested for the effect. The physical process involved is discussed and the importance of the effect in broadcasting and in the study of the ionosphere E layer is indicated. A long summary in English is included. See also 1758 of 1951.

621.396.11:621.317.353.3:551.510.535 1168

Experimental Determination of the Resonance Curves in the Motion of the Slow Electrons in the Upper Atmosphere—M. Cutolo. (*Nuovo Cim.*, vol. 9, pp. 391-407; May 1, 1952.) Theory of gyrointeraction between waves in an ionized medium is reviewed. Double-hump or single-hump resonance curves are obtained, depending in the experimental conditions. Experiments made in Italy in 1950 are described, when by varying the frequency of the unmodulated wave the transition from the double-hump to the single-hump curve was observed. See also 720 of March.

621.396.812:621.396.621.59 1169

Long-Range Communication Trends—Crosby. (See 1172.)

RECEPTION

621.396.62/63 1170

Conelrad Receiver With Built-In Alarm—R. E. Quenstedt. (*Electronics*, vol. 27, pp. 156-157; Jan., 1954.) Description of a FM broadcast receiver with carrier-failure alarm, for use in controlled broadcast stations required to monitor a regional parent station of a civil defence scheme.

621.396.621+621.397.621 1171

Radio and Television at the 16th Salon National—P. A. François. (*TSP et TV*, vol. 29, pp. 359-364 and 393-394; Nov./Dec., 1953.) General report of the Paris exhibition, Sept. 25-Oct. 5, 1953, with tabulated details of the television receivers shown. Reports of the exhibition are also given in *Toute la Radio*, vol. 20, pp. 410-413; Nov., 1953, and *Télévision*, pp. 264-266; Nov., 1953.

621.396.621.59:621.396.812 1172

Long-Range Communication Trends—M. G. Crosby. (*Trans. I.R.E.*, vol. CS-1, pp. 41-53; July, 1953.) Various types of fading due to multipath ionospheric transmission are reviewed and methods of reducing fading effects are discussed. The interference rejection and IF/AF selectivity transfer obtained with exalted-carrier detection are noted. The advantage of frequency-shift keying for telegraphy is pointed out. The application of exalted-carrier and ssb methods in a triple-diversity system is illustrated.

STATIONS AND COMMUNICATION SYSTEMS

621.376.2:621.396.5:621.396.822 1173

Noise and Radiotelephony with Amplitude

- Modulation**—P. Marcou. (*Ann. Télécommun.*, vol. 8, pp. 339–351; Oct., 1953.) Dsb and ssb AM systems are compared, using as criterion the signal/noise ratio at the receiver output when white noise is mixed with the rf signal. The effect of different detecting processes on the signal/noise ratio is analyzed. The ssb system makes better use of available power inasmuch as (a) the carrier is suppressed or reduced, (b) the rf noise is halved, and (c) reception is linear; the advantage due to this last feature only becomes significant, however, for output signal/noise ratios too low to give good intelligibility even with this improvement. With ssb transmissions, the ear accepts quasi-synchronous demodulation, not necessarily in phase.
- 621.39.001.11:621.376** 1174
Comparative Study of Modulation Methods—R. M. Page. (*Trans. I.R.E.*, vol. CS-1, pp. 13–22; July, 1953.) To express the results of information theory in practical terms, direct, coded and modulated-carrier coded transmission systems are analysed on the basis of Shannon's equation. Basic transformer theory is applied to the action of coding and an expression is derived in relating power ratio to bandwidth ratio in terms of the dynamic range of the information. Curves showing signal/noise ratio at a receiver output as a function of signal input power for ssb AM, dsb AM, wide-band FM and binary-code pcm systems are compared.
- 621.39.001.11:[621.394+621.396.3]** 1175
The Transmission of Intelligence in Type-script—I. S. Coggeshall. (*Trans. I.R.E.*, vol. CS-1, pp. 4–13; July, 1953.) Practical aspects of the application of communication theory in telegraphy are reviewed.
- 621.396.41** 1176
Properties of a Multiplex Signal with Pulses of Alternate Sign—L. Le Blan. (*Compt. Rend. Acad. Sci.*, (Paris), vol. 237, pp. 1662–1664; Dec. 21, 1953.) Analysis of a two-channel system in which one channel uses positive AM pulses while the other uses negative AM pulses. Simple methods can be used to separate the two signals at the receiver; in general, arrangements must be provided for eliminating cross-talk.
- 621.396.44** 1177
Simplified Carrier-Current System for Short Distances—G. H. Bast and J. L. Hurault. (*Câbles & Transm.*, vol. 7, pp. 185–217; July, 1953.) The paper is based on an investigation for the Netherlands Administration. A detailed study is made of design requirements for a multiplex system operating over distances of 20–300 km on any suitable existing lines. In a discussion of economic aspects, the attenuation required to avoid cross-talk is calculated for different channel widths, and the choice of a 6-kc bandwidth is explained. Full descriptions are given of terminal equipment for a 32-channel system on symmetrical-pair cables and the main oscillators and control circuits at the central station.
- 621.396.662.029.5/6** 1178
Design Trends in Communication Equipment—L. M. Craft. (*Trans. I.R.E.*, vol. CS-1, pp. 22–30; July, 1953.) General discussion of omnichannel operation of usw and sw equipment. Outline descriptions are given, with illustrations, of automatic tuning and channel-selection units incorporated in Collins transmitters and receivers.
- 621.396.712** 1179
La Maison de la Radio, Paris—H. Testemale. (*Télév. Franç.*, no. 100, pp. 23–25; Nov., 1953.) A competition has been held for the design of a building to serve as a comprehensive broadcasting centre; the winning design is described.
- 621.396.712.029.62:621.396.81** 1180
U.S.W. Planning in Austria—J. Burgstaller. (*Radio Tech. (Vienna)*, vol. 29, pp. 340–345; Oct., 1953.) Formulas and curves for the theoretical field strength of horizontally polarized waves received at a height 30 feet above ground, and for the correction factor for the attenuation due to diffraction in mountainous districts are given and discussed. The frequency considered is 98 mc. Maps show the estimated area coverage provided by six 25-kw transmitting stations and, in the case of the Klagenfurt transmitter, the effects of different aerial heights and radiated powers.
- 621.396.932** 1181
Aspects of Naval Communications Systems—J. A. Krcek. (*Trans. I.R.E.*, vol. CS-1, pp. 54–58; July, 1953.) General review of problems and developments in the design and arrangement of radio equipment aboard a communications vessel which may carry about 150 receivers and 60 transmitters.
- 621.396.933** 1182
A Discussion of United Air Lines V.H.F. Network Developments—K. J. Rhead. (*Trans. I.R.E.*, no. PGAE-8, pp. 9–11; June, 1953.) The network comprises five transmitter-receiver stations, with automatic locking out of either transmitter or receiver when the other unit is in operation. Preliminary experience indicates that intermodulation effects are considerably reduced by using a stable oscillator, by sub-channelling arrangements, and by restriction of the speech band to the range 200–2,500 cps.
- SUBSIDIARY APPARATUS**
- 621-526** 1183
Analogue Methods for Optimum Servomechanism Design—F. C. Fickeisen and T. M. Stout. (*Trans. AIEE*, vol. 71, part II, pp. 244–250; 1952. Discussion, p. 250.)
- 621-526** 1184
Feedback Control Systems with Dead-Time Lag or Distributed Lag by Root-Locus Method—Y. Chu. (*Trans. AIEE*, vol. 71, part II, pp. 291–296; 1952.) Generalization and application of the method originated by Evans (2337 of 1952).
- 621-526** 1185
Synthesis of Feedback Control System by Phase-Angle Loci—Y. Chu. (*Trans. AIEE*, vol. 71, part II, pp. 330–339; 1952.) A modification of Evans' root-locus method (2337 of 1952).
- 621-526** 1186
The Use of Nonlinear [tachometric] Feedback to Improve the Transient Response of a Servomechanism—J. B. Lewis. (*Trans. AIEE*, vol. 71, part II, pp. 449–453; 1952. Discussion, p. 453.)
- 621-526:621.3.016.35** 1187
Stabilization of a Servomechanism subject to Large Amplitude Oscillation—E. S. Sherrard. (*Trans. AIEE*, vol. 71, part II, pp. 312–324; 1952.) The frequency-response method of analysis developed by Kochenburger (224 of 1951) is applied to a system containing a saturable amplifier and in determining the required nonlinear stabilizing filter.
- 621-526:621.3.016.35** 1188
Stability Limits for Third-Order Servomechanisms—T. J. Higgins and J. G. Levinthal. (*Trans. AIEE*, vol. 71, part II, pp. 459–466; 1952. Discussion, pp. 466–467.) Curves are derived giving directly the roots and coefficients of specified cubic characteristic equations. Their use in facilitating analysis and design of servo systems is explained and illustrated.
- 621-526:621.316.7** 1189
The Analysis of Sampled-Data Systems—
- J. R. Ragazzini and L. A. Zadeh. (*Trans. AIEE*, vol. 71, part II, pp. 225–232; 1952. Discussion, pp. 232–234.) Full paper; summary abstracted in 1801 of 1953.
- 621.311.6** 1190
Stable Power Supplies for Microwave Standards—W. P. Ernst. (*Electronics*, vol. 27, pp. 168–171; Jan., 1954.) A description of the power-supply system for operating the klystron frequency standards at the National Bureau of Standards.
- 621.314.634.004** 1191
Selenium Rectifiers—Factors in their Application—J. Gramels. (*Bell. Sys. Tech. Jour.*, vol. 32, pp. 1469–1492; Nov., 1953.)
- 621.318.5** 1192
Design of Relays—(*Bell Sys. Tech. Jour.*, vol. 33, pp. 1–259; Jan., 1954.) A symposium of papers, dealing with design, production, service, and measurements.
- TELEVISION AND PHOTOTELEGRAPHY**
- 621.397.2:535.623** 1193
The Colorplexer—a Device for Multiplexing Color Television Signals in accordance with the N.T.S.C. Signal Specifications—E. E. Gloystein and A. H. Turner. (*Proc. I.R.E.*, vol. 42, pp. 204–212; Jan., 1954.) The functions of matrixing, band limiting, delay correction, modulating, burst generating, and mixing are described in detail. Waveforms photographed at several points in the colorplexer are shown for one standard color-bar signal.
- 621.397.2:535.623** 1194
Transmission of Color over Inter-City Television Networks—J. R. Rae. (*Proc. I.R.E.*, vol. 42, pp. 270–273; Jan., 1954.) The additional gain and delay equalizers required for color transmission and the method for shifting the color information within the pass band of coaxial cable are discussed.
- 621.397.24:621.315.212.4** 1195
The Birmingham-Manchester-Holme-Moss Television-Cable System—R. J. Halsey and H. Williams. (*P.O. Elec. Eng. Jour.*, vol. 46, parts 3 and 4, pp. 118–121 and 171–176; Oct., 1953 and Jan., 1954.) Shortened version of paper noted in 1147 of 1953.
- 621.397.24:621.372.55** 1196
Adjustment of Bridged-T Phase-Correction Networks used in Television Equipment—H. Martin. (*Câbles & Trans.*, vol. 7, pp. 175–184; July, 1953.) Properties of equalizing networks for television cables are reviewed. A practical method is described, based on measurement of impedance at a frequency for which the phase shift is 180 degrees, by which network impedance can be adjusted to within $\pm 2\%$ of the correct value throughout the pass band. Propagation-time/frequency characteristics are shown for two types of network.
- 621.397.5** 1197
Fundamental Problems of Subscription Television: the Logical Organization of the Telemeter System—L. N. Ridenour and G. W. Brown. (*Jour. Soc. Mot. Pict. & Telev. Engrs.*, vol. 61, pp. 183–194; Aug., 1953.) The basic principles of a satisfactory "pay-as-you-view" system are considered. Essential requirements are (a) provision of a coin-actuated mechanism controlling a signal decoder, (b) program sales on a variable-price basis, the unit being a single programme rather than a unit of time, (c) announcement of details of the available program on the channel carrying the programme, for the benefit of anyone tuning in to that channel, and (d) an accurate record of each show purchased.
- 621.397.5** 1198
Camera Adapter for TV Receivers—L. E. Flory, W. S. Pike, and G. W. Gray. (*Electronics*, vol. 27, pp. 141–143; Jan., 1954.) A com-

plete television system for domestic or business use comprises a vidicon camera unit, the picture signals from which are transmitted to the receiver on a vlf carrier via cable; operating voltages for the camera tube are derived from the receiver circuits.

- 621.397.5:535.623 1199
Second Color Television Issue—(PROC. I.R.E., vol. 42, pp. 1-348; Jan., 1954.) The whole of this issue is devoted to an account of developments in color television since 1951. The first group of papers comprises 22 contributions from the National Television System Committee; the titles of these papers, with the page references and the authors' names, are listed below. The second group comprises 27 contributions from individual workers on various branches of the subject; these papers are abstracted separately.
 The Future of Color Television (pp. 5-7).—W. R. G. Baker.
 Basic Concepts and Evolution of Color Television (pp. 7-9).—E. W. Engstrom.
 Psychophysical and Electrical Foundations of Color Television (pp. 9-11).—A. V. Loughren.
 The NTSC—An Exercise in Technical Coordination (pp. 11-14).—D. B. Smith.
 NTSC Signal Specifications (pp. 17-19).
 NTSC Color Television Field Test (pp. 20-43).—R. DeCola, R. E. Shelby, and K. McIlwain.
 The NTSC Monographs (pp. 43-45).—D. G. Fink.
 The NTSC Color Television Standards (pp. 46-48).
 Colorimetry in Television: Parts 2 and 3 (pp. 48-57).—F. J. Bingley.
 The Choice of Axes and Bandwidths for the Chrominance Signals in NTSC Color Television (pp. 58-59).—G. H. Brown.
 The Constant Luminance Principle in NTSC Color Television (pp. 60-66).—W. F. Bailey
 Mathematical Formulations of the NTSC Color Television Signal (pp. 66-71).—G. H. Brown.
 Transfer Characteristics in NTSC Color Television (pp. 71-78).—F. J. Bingley.
 Choice of Chrominance Subcarrier Frequency in the NTSC Standards (pp. 79-80).—I. C. Abrahams.
 The "Frequency Interleaving" Principle in the NTSC Standards (pp. 81-83).—I. C. Abrahams.
 Quadrature Cross Talk in NTSC Color Television (pp. 84-90).—W. F. Bailey and C. J. Hirsch.
 Narrow-Band Transmission of the NTSC Color Signal (pp. 90-91).—J. G. Reddeck.
 System Delay Characteristics in NTSC Color Television (pp. 92-95).—R. C. Palmer.
 Effect of Transmitter Characteristics on NTSC Color Television Signals (pp. 95-105).—G. L. Fredendall and W. C. Morrison.
 Color-Carrier Reference Phase Synchronization Accuracy in NTSC Color Television (pp. 106-133).—D. Richman.
 621.397.5:535.623 1200
The Concept of Transmission Primaries in Color Television—P. W. Howells. (PROC. I.R.E., vol. 42, pp. 134-138; Jan., 1954.) The concept of color space is discussed. The location of the three transmission primaries of the NTSC system (namely, the monochrome signal and the two color signals) in the CIE color space is indicated.
 621.397.5:535.623 1201
Colorimetric Analysis of the NTSC Color Television System—D. C. Livingston. (PROC. I.R.E., vol. 42, pp. 138-150; Jan., 1954.) Formulas are developed which enable color fidelity, compatibility, and adherence to the constant-luminance principle to be assessed. Three different forms of the NTSC system are compared; the superiority of the standard form is indicated. See also *Convention Record I.R.E., part 4*, pp. 51-55; 1953.

- 621.397.5:535.623 1202
Quantitative Spectral Measurements in Color Television—J. A. Rado and W. L. Hughes. (PROC. I.R.E., vol. 42, pp. 151-156; Jan., 1954.) Measurements of the spectral sensitivities of the pickup devices and of the colorimetric characteristics of the display devices are discussed. Techniques are described using narrow-band optical-interference filters in conjunction with "red-pass" gelatin filters.
 621.397.5:535.623 1203
Wide-Range Chromaticity Measurements with Photoelectric Colorimeter—J. B. Chatten. (PROC. I.R.E., vol. 42, pp. 156-160; Jan., 1954.) Detailed description of a tristimulus colorimeter sufficiently accurate for general work in color television.
 621.397.5:535.623 1204
Reproduction of Colors in Outdoor Scenes—D. L. MacAdam. (PROC. I.R.E., vol. 42, pp. 166-174; Jan., 1954.) Available spectrophotometric and colorimetric data on the colors of skin, hair, grass, foliage, sky, and earth are summarized and measurements of typical color-film reproductions are presented. Subjective assessments of color-reproduction quality are discussed on the basis of these data.
 621.397.5:535.623 1205
The Use of Electronic Masking in Color Television—R. P. Burr. (PROC. I.R.E., vol. 42, pp. 192-200; Jan., 1954.) A discussion of the use of electrical networks for reducing the effects of photographic cross-coupling introduced when using subtractive color transparencies as material for television transmission.
 621.397.5:535.623 1206
Matrix Networks for Color TV—W. R. Feingold. (PROC. I.R.E., vol. 42, pp. 201-203; Jan., 1954.) Summation-type circuits required for color-television transmitters and receivers are described.
 621.397.5:535.623 1207
Transients in Color Television—P. W. Howells. (PROC. I.R.E., vol. 42, pp. 212-220; Jan., 1954. *Convention Record I.R.E., part 4*, pp. 24-34; 1953.) When a color transient occurs, the three components of the transmitted signal respond in a manner determined by the characteristics of the individual channels. The system response is characterized by the resulting path along which the reproduced color point moves through the color space from its initial to its final location. An analysis is made of such paths, and the corresponding subjective effects are discussed.
 621.397.5:535.623 1208
Transition Effects in Compatible Color Television—J. B. Chatten. (PROC. I.R.E., vol. 42, pp. 221-228; Jan., 1954.) An experimental video-frequency television system is described for investigating the best choice of the three independent color-signal components to be transmitted. A description is given of an arrangement for predistorting the luminance signal to compensate for luminance variations arising in the reproduction of color transients.
 621.397.5:535.623 1209
Reproduction of Luminance Detail by NTSC Color Television Systems—D. C. Livingston. (PROC. I.R.E., vol. 42, pp. 228-234; Jan., 1954.) Three different forms of the NTSC system are compared to determine the relative merits of different methods of gamma correction. The system using a luminance corrector in the transmitter is judged to be the best.
 621.397.5:535.623 1210
Delay Equalization in Color Television—G. L. Fredendall. (PROC. I.R.E., vol. 42, pp. 258-262; Jan., 1954.) An equalizer designed by the potential-analog method consists of four conventional all-pass filter sections.

- 621.397.5:535.623.778.5 1211
Brightness Modification Proposals for Television Color Film—W. L. Brewer, J. H. Ladd, and J. E. Pinney. (PROC. I.R.E., vol. 42, pp. 174-191; Jan., 1954.) It is recommended that (a) the effective luminance range should be modified, either in the film or in the television system, to conform to that available on the kinescope, and (b) kinescope reproductions of film color should be made lighter with increasing saturations. Alternative methods of achieving the color-dependent brightness compensation are discussed.
 621.397.5:535.623].001.4 1212
Methods of Verifying Adherence to the NTSC Color Signal Specifications—Luther. (See 1150.)
 621.397.5:535.623].001.4 1213
A Versatile Approach to the Measurement of Amplitude Distortion in Color Television—Bauer. (See 1151.)
 621.397.5:535.623].001.4 1214
Test Instruments for Color Television—Morrison, Karstad, and Behrend. (See 1152.)
 621.397.61:535.623 1215
Alignment of a Monochrome TV Transmitter for Broadcasting NTSC Color Signals—J. F. Fisher. (PROC. I.R.E., vol. 42, pp. 263-270; Jan., 1954.) A detailed account of the procedure used to adapt the WPTZ (Philadelphia) station.
 621.397.611:535.623 1216
Image Orthicons for Color Cameras—R. G. Neuhauser, A. A. Rotow, and F. S. Veith. (PROC. I.R.E., vol. 42, pp. 161-165; Jan., 1954.) Operating conditions and performance characteristics of the R.C.A. Type-1854 are given.
 621.397.611.2 1217
The Flying-Spot Scanning Systems by means of the MC 13-16—J. J. P. Valetton and F. H. J. van der Poel. (*Elec. Appl. Bull.*, vol. 14, pp. 77-90; June/July, 1953.) A detailed description is given of the flying-spot scanning system for deriving a picture signal for modulating a television transmitter from transparent positives or negatives. The MC 13-16 cr tube used has magnetic focusing and deflection systems. Circuit means are indicated for correcting the signal for the afterglow of the fluorescent screen.
 621.397.62+621.396.621 1218
Radio and Television at the 16th Salon National—François. (See 1171.)
 621.397.62 1219
Technical Description of a Television Receiver—A. Bilotti. (*Rev. Teleg. Electronica*, (Buenos Aires), no. 492, pp. 555-560; Sept., 1953.) Detailed circuit diagram and component values are given for a receiver operating on the intercarrier system, to suit the Argentina television standards, namely, negative picture signal, line frequency 15,625 per second, frame frequency 50 per second, aspect ratio 3:4, FM sound, separation of 4.5 mc between picture and sound carriers, channel width 6 mc. Reception on all twelve vlf channels is possible.
 621.397.62 1220
The D.C. Component in Television—W. T. Cocking. (*Wireless World*, vol. 60, pp. 63-66; Feb., 1954.) Birkinshaw's views (552 of February) are generally supported, but criticism is made of the well known circuit in which the cathode of the cr tube is fed from the anode of the video stage through a voltage divider. The low input resistance of the tube thus connected may lead to a 50 per cent reduction of the dc component. Various modifications of the coupling circuit are suggested for eliminating this defect.
 621.397.62 1221
A Printed-Circuit Television Receiver—

G. Székely. (*Télévision*, no. 37, pp. 230-232; Oct., 1953.) Brief description of a new French receiver. All circuits, excepting time bases and supply, but including deflection coils, are printed.

621.397.62:535.623 1222
Improving the Transient Response of Television Receivers—J. Avins, B. Harris, and J. S. Horvath. (*Proc. I.R.E.*, vol. 42, pp. 274-284; Jan., 1954.) An examination is made of the delay distortion produced in the IF amplifier, and of the extent to which this is compensated by the peaking circuits of the video detector and amplifier. Factors determining cross-talk between the two color-difference signals in the NTSC system are discussed. The use of a standard transmission monitor throughout the industry is recommended.

621.397.62:535.623 1223
Theory of Synchronous Demodulator as used in NTSC Color Television Receiver—D. C. Livingston. (*Proc. I.R.E.*, vol. 42, pp. 284-287; Jan., 1954.) See 3129 of 1953.

621.397.62:535.623 1224
The D.C. Quadricorrelator: a Two-Mode Synchronization System—D. Richman. (*Proc. I.R.E.*, vol. 42, pp. 288-299; Jan., 1954.) A description is given of an automatic-phase-control circuit adapted for color synchronization in the NTSC system. The arrangement is simple, reliable, and noise-immune. The pull-in and hold-in modes of operation are made independent of each other by means of an automatic switch. See also *Convention Record I.R.E.*, part 4, pp. 13-23; 1953.

621.397.62:535.623 1225
Processing of the NTSC Color Signal for One-Gun Sequential Color Displays—B. D. Loughlin. (*Proc. I.R.E.*, vol. 42, pp. 299-308; Jan., 1954.) Receiver arrangements of two types are described, namely those in which the color subcarrier signal is modified, and those in which the luminance signal is modified. Circuits of the latter type generally demodulate the color signal to some extent and correct the luminance signal to produce constant luminance.

621.397.62:535.623 1226
Compatible Color Picture Presentation with the Single Gun Tricolor Chromatron—J. D. Gow and R. Dorr. (*Proc. I.R.E.*, vol. 42, pp. 308-315; Jan., 1954.) Techniques are discussed for operating the tube previously described [3131 of 1953 (Dressler)]. Circuit nonlinearity is corrected so as to ensure color balance at different brightness levels.

621.397.62:535.623 1227
Improvements in the R.C.A. Three-Beam Shadow-Mask Color Kinescope—M. J. Grimes, A. C. Grimm, and J. F. Wilhelm. (*Proc. I.R.E.*, vol. 42, pp. 315-326; Jan., 1954.) Advances made since the original design [844 of 1952 (Law)] are described.

621.397.62:535.623 1228
The C.B.S.-Colortron: a Color Picture Tube of Advanced Design—N. F. Fyler, W. E. Rowe, and C. W. Cain. (*Proc. I.R.E.*, vol. 42, pp. 326-334; Jan., 1954.) Full details are given of a three-gun tricolor tube in which the phosphor dots are applied directly to the curved end-plate, and a self-supporting curved mask is provided. See also *Tele-Tech.*, vol. 12, pp. 73, 150, 165; Nov., 1953.

621.397.62:535.623 1229
A Laboratory Receiver for Study of the NTSC Color Television System—C. Masucci, J. J. Insalaco, and R. Zitta. (*Proc. I.R.E.*, vol. 42, pp. 334-343; Jan., 1954.)

621.397.62:621.314.632 1230
Some High Frequency Effects in Ger-

manium Diodes with Special Reference to Television Sound Detectors—D. D. Jones and B. C. Brodribb. (*Electronic Eng.*, vol. 26, pp. 33-35; Jan., 1954.) The measured performance of Ge diodes at HF may differ appreciably from that predicted from the static characteristics. The deviations, which may give rise to highly nonlinear detection, are shown to be consistent with hole-storage effects in the Ge; these effects can be eliminated by production techniques designed to reduce the lifetime of the holes. An indication is given of suitable test methods.

621.397.62:621.375.2 1231
Video Amplifier Design Charts—W. K. Squires and H. L. Newman. (*Electronics*, vol. 27, pp. 190-192, 194; Jan., 1954.) Charts based on transient-response analysis are presented.

621.397.8 1232
Image Gradation, Graininess and Sharpness in Television and Motion-Picture Systems: Part 2—The Grain Structure of Motion Picture Images—An Analysis of Deviations and Fluctuations of the Sample Number—O. H. Schade. (*Jour. Soc. Mot. Pict. & Telev. Engrs.*, vol. 58, pp. 181-222; March, 1952.) A treatment of aperture-response theory as applied to the evaluation of relative deviation in motion-picture processes. Part 1: 2293 of 1951.

621.397.8 1233
Image Gradation, Graininess and Sharpness in Television and Motion-Picture Systems: Part 3—The Grain Structure of Television Images—O. H. Schade. (*Jour. Soc. Mot. Pict. & Telev. Engrs.*, vol. 61, pp. 97-164; Aug., 1953.) An adequate description of granularity in television and motion-picture frames requires specification of the sine-wave spectrum and signal/deviation ratio in the retinal image as a function of luminance and for a specified viewing distance. An assessment of the perception of deviations can be made by introducing the characteristic of threshold signal/deviation ratios as the reference level. Part 2: 1232 above.

621.397.8 1234
Note on the Influence of Phase in Television—A. Dubec. (*Onde élect.*, vol. 33, pp. 606-614; Nov., 1953.) Methods of calculating phase/frequency characteristics are reviewed in relation to the design of television receivers.

621.397.8 1235
Eye Movements in Connexion with Television Viewing—M. P. Lord. (*Nature*, (London), vol. 172, pp. 964-965; Nov. 21, 1953.) A comparison of movements made when viewing interlaced and sequentially scanned pictures indicates little difference; hence instability and "crawling" associated with interlaced scan cannot be immediately explained in terms of the pattern of eye movements.

TRANSMISSION

621.375.227.029.4:621.3.018.783 1236
Nonlinear Distortion in a Class-B Push-Pull Amplifier with Transformer Output—F. Böttcher. (*Telefunken Ztg.*, vol. 26, pp. 313-322; Aug., 1953.) Expressions for the distortion, up to the 4th harmonic, are derived for the case of imperfect magnetic coupling between the halves of the primary winding of the output transformer. An approximate numerical calculation is made for the modulator output stage of an anode-modulated transmitter.

621.396.664 1237
Speech Clippers and their Operation—W. Schreuer. (*Short Wave Mag.*, vol. 11, pp. 465-469; Oct., 1953.) Average modulation depth is increased without introducing overmodulation on voice peaks by using an amplitude limiter followed by a low-pass filter, with a cut-off frequency ~ 3 kc. High-level and low-level systems are discussed.

TUBES AND THERMIONICS

621.314.63:546.289 1238
Recovery Currents in Germanium p - n Junction Diodes—R. G. Shulman and M. E. McMahon. (*Jour. Appl. Phys.*, vol. 24, pp. 1267-1272; Oct., 1953.) When a diode biased in the forward direction has a reverse voltage suddenly applied, a large transient ("recovery") current flows. Values of this current based on a proposed mechanism involving diffusion of stored minority carriers to the barrier are compared with experimental results. The application to variable time-delay devices is discussed.

621.314.632:546.289 1239
Theory of the Forward Characteristic of Injecting Point Contacts—P. C. Banbury. (*Proc. Phys. Soc.*, vol. 66, pp. 833-840; Oct. 1, 1953.) Curvature of 0.01 per cent uses cold-cathode glow. The voltage/current relation for forward voltages across a metal/semiconductor point contact is derived for the case when the current is carried by injected minority carriers. Unit injection ratio is assumed and recombination effects are neglected. Results of measurements on contacts under illumination and experimentally determined forward-voltage/current characteristics of a Ge-W rectifier are in satisfactory agreement with theory.

621.314.632:546.289 1240
Forward Characteristic of Injecting Area Contacts on Germanium—H. K. Henisch and F. D. Morten. (*Proc. Phys. Soc.*, vol. 66, pp. 841-844; Oct. 1, 1953.) Measurements were made on 4.2- Ω . cm n -type and on 12- Ω . cm p -type Ge illuminated with white light. Au or Ag rectifying electrodes were used. The results found for the floating potential, the contact capacitance and the derived current/voltage barrier characteristic are given and compared with those derived from theory.

621.314.632:546.289:537.312.6 1241
Thermal Effects at Point-Contact Diodes—P. M. Tipple and H. K. Henisch. (*Proc. Phys. Soc.*, vol. 66, pp. 826-832; Oct. 1, 1953.) Measurements, by a thermoelectric method, have been made of the contact temperature of a Ge diode, at several points on the voltage/current characteristics. The voltage turnover occurs at a critical contact temperature, which is constant for a given specimen. Also, the temperature gradients in the vicinity of a hot point contact may increase the contact resistance. This observation is discussed.

621.314.632:546.289:537.312.6 1242
Thermal Effects in Point-Contact Rectifiers—H. L. Armstrong. (*Jour. Appl. Phys.*, vol. 24, pp. 1332-1333; Oct., 1953.) The relation between thermal effects and the shape of the reverse characteristic is investigated for a Type-1N34 Ge rectifier.

621.314.632:621.397.62 1243
Some High Frequency Effects in Germanium Diodes with Special Reference to Television Sound Detectors—Jones and Brodribb. (*See* 1230.)

621.314.7 1244
Design Theory of Junction Transistors—J. M. Early. (*Bell Sys. Tech. Jour.*, vol. 32, pp. 1271-1312; Nov., 1953.) "The small signal ac transmission characteristics of junction transistors are derived from physical structure and bias conditions. Effects of minority carrier flow and of depletion layer capacitances are analyzed for a one dimensional model. The ohmic spreading resistance of the base region of a three dimensional model is then approximated. Short circuit admittances representing minority carrier flow, depletion layer capacitances, and ohmic base resistance elements are then combined into an equivalent circuit. Theoretical calculations are compared to observations for two typical designs."

- 621.314.7:546.28+546.289 1245
A Study of Carrier Injecting Properties of Emitter Contacts and Light Spots at Normal and Moderately Elevated Temperatures—C. A. Hogarth. (*Proc. Phys. Soc.*, vol. 66, pp. 845-858; Oct. 1, 1953.) "The method of determining the injection efficiency γ of an emitter contact (described previously by Shockley, Pearson and Haynes [380 of 1950]) is discussed and some of the difficulties of the method and the interpretation of experimental results are described. The effects of a fine spot of white light when used as an emitter and hence as a conductivity modulator are investigated and an equivalent minority carrier current for a given optical assembly can be determined. This procedure suggests an experimental method for the determination of γ as a function of temperature. A simple theory for γ in terms of forbidden energy gap, depth of Fermi level, and barrier height ϕ is given and applied to the determination of barrier heights at room temperature, at elevated temperatures, and when an emitter contact on germanium is illuminated. Theoretical curves relating γ and ϕ are presented for Ge and Si of various impurity concentrations. The experiments carried out at elevated temperatures suggest that the surface states on germanium lie at the top of the filled band and that their density is of order 10^{16} - 10^{11} cm⁻²."
- 621.314.7:546.28 1246
Forming Silicon Point-Contact Transistors—H. Jacobs, F. A. Brand, and W. Matthei. (*Jour. Appl. Phys.*, vol. 24, p. 1340; Oct., 1953.) Particles of a suitable impurity material were pressed between a pointed tungsten electrode and the Si sample, and a high-density current was passed through the junction in a N₂ atmosphere. Best results were obtained using Sb to form *p-n-p* transistors and Al to form *n-p-n* transistors. Some test results are tabulated.
- 621.314.7:621.375.4.029.3 1247
Power Transistors for Audio Output Circuits—L. J. Giacoletto. (*Electronics*, vol. 27, pp. 144-148; Jan., 1954.) Junction transistors cooled by liquids and by metal radiators are described. Analysis previously developed for small-signal operation is adapted to power operation, and the influence of finite base-lead resistance, temperature, frequency and source resistance is examined. Biasing arrangements for typical audio output circuits are discussed.
- 621.314.7:621.396.822 1248
Shot Noise in Junction Transistors—H. C. Montgomery and M. A. Clark. (*Jour. Appl. Phys.*, vol. 24, pp. 1337-1338; Oct., 1953.) The noise figure calculated from Montgomery's formula (643 of 1953) is in fair agreement with the values measured in a *p-n-p* alloy transistor at frequencies above those for which the noise is inversely proportional to frequency.
- 621.383.2:621.317 1249
The Photodianode—G. Deloffre, É. Pierre, and J. Roig. (*Compt. Rend. Acad. Sci.*, (Paris), vol. 237, pp. 1507-1509; Dec. 9, 1953.) The "photodianode" is a tube with a plane photoemissive cathode and two linear anodes arranged parallel to and equidistant from the cathode. The anodes are connected via separate equal resistors to the positive supply terminal, thus there is a potential difference between them depending on the position of the illuminated area; this potential difference is determined by measuring the current through a galvanometer connected between the anodes. The arrangement responds to variations of the direction of a light beam, and can be used for accurate measurements of displacement and rotation.
- 621.383.4 1250
On the Relation between the Speed of Response and the Detectivity of Lead Sulfide Photoconductive Cells—R. C. Jones. (*Jour. Opt. Soc. Amer.*, vol. 43, pp. 1008-1013; Nov., 1953.)
- 621.383.5:546.23 1251
A New Type of Fatigue of Photocells—G. Blet. (*Compt. Rend. Acad. Sci.* (Paris), vol. 238, pp. 228-230; Jan. 11, 1954.) The impedance of a Se barrier-layer cell was found to drop immediately on illumination, returning to its original value only very slowly when the illumination was cut off. The suggested explanation is that the liberated photoelectrons suffer collisions which reduce their energy and hence delay their return to their original positions.
- 621.385:681.142 1252
Valve Reliability in Digital Calculating Machines—Knight. (*See* 984.)
- 621.385.029.6 1253
Instabilities in the Smooth-Anode Cylindrical Magnetron—L. A. Harris. (*Jour. Appl. Phys.*, vol. 24, p. 1335; Oct., 1953.) Correction to paper noted in 3293 of 1952. An error in equation (38) invalidates the previous conclusions. The system is stable, with a set of real characteristic frequencies.
- 621.385.032.213 1254
The Motion of Idealized Vacuum Tube Filaments under Shock—H. S. Thomas. (*Jour. Appl. Phys.*, vol. 24, pp. 1341-1342; Nov., 1953.) An analysis is made of the motion of an ideal clamped-end string; approximate formulas are derived for the maximum displacement for accelerations of the supports corresponding to three different types of shock. The results are applicable to the investigation of filament-to-grid shorting.
- 621.385.032.216 1255
Molded Thermionic Cathodes—D. MacNair, R. T. Lynch, and N. B. Hannay. (*Jour. Appl. Phys.*, vol. 24, pp. 1335-1336; Oct., 1953.) The cathodes are made of sintered mixtures of Ni powder and (Ba, Sr)CO₃ on a Ni base. Test results indicate a very high resistance to deactivation by gases and ion bombardment. A comparison with sprayed oxide and other cathodes is made.
- 621.385.032.216 1256
Deterioration of Valve Performance due to Growth of Interface Resistance—G. H. Metson and M. F. Holmes. (*P.O. Elect. Eng. Jour.*, vol. 46, part 4, pp. 198-199; Jan., 1954.) Results of measurements on a high-slope pentode indicate that the development of interface resistance between core and coating of the oxide cathode [2378 of 1952 (Child)] can be eliminated by replacing the usual Ni core by a material free from Si, e.g. commercially pure Pt. The lifetime of common receiving tubes might be doubled.
- 621.385.032.216:546.831 1257
Thermionic Emission and Optical Emissivity of Zirconium—G. Mesnard. (*Le Vide*, vol. 8, pp. 1392-1399; July/Sept., 1953.) Measurements were made of the properties of cathodes prepared by coating W or Mo wires with zirconium oxide. The activation by thermal treatment and the development of emission with time were studied. Spectral emissivity, resistance and required heating power are discussed. Similarities are noted between these cathodes and those using other materials, particularly thorium.
- 621.385.032.216:546.841.4-31 1258
Thermionic Properties of Thoria Coatings on Thoriated Molybdenum—G. Mesnard. (*Le Vide*, vol. 8, pp. 1377-1383; July/Sept., 1953.) Measurements of the emission from (a) thoriated molybdenum, (b) thoria coatings on non-thoriated molybdenum, and (c) thoria coatings on thoriated molybdenum indicated that no appreciable advantage is obtained by thoriating the molybdenum base. The effects of treatment at high and at medium temperatures are discussed.
- 621.385.032.24 1259
Gold as a Grid Emission Inhibitor in the Presence of an Oxide-coated Cathode—B. O. Baker. (*Brit. Jour. Appl. Phys.*, vol. 4, pp. 311-315; Oct., 1953.) "Emission measurements have been made on gold-plated molybdenum and gold-plated manganese-nickel grids in the presence of an oxide-coated cathode. For grids which cannot be designed to operate below 350 degrees C. a minimum thickness of 1 μ of gold will suppress grid emission. Silver is not so reliable, but is effective in some cases."
- 621.385.2:621.316.722.1 1260
Characteristics of the Temperature-Limited Diode Type 29C1—V. H. Attree, F. A. Benson and M. S. Seaman. (*Electronic Eng.*, vol. 26, p. 42; Jan., 1954.) Comment on 595 of February and authors' reply.
- 621.385.3:621.396.822 1261
Experimental Investigation of Grid Noise—N. Houlding and A. E. Glennie. (*Wireless Eng.*, vol. 31, pp. 35-42; Feb., 1954.) "Results are given of a detailed investigation of triode noise factor, with particular reference to correlation of induced grid noise with shot noise. It is deduced that correlation is very slight and that, although the optimum value of noise factor can be calculated fairly accurately from the values of shot noise and optimum source resistance, the latter must be found by experiment and therefore the theory is not of major practical importance."
- 621.385.832 1262
Theory of the Triode Electron Gun with Cylindrical Symmetry—É. Labin. (*Onde élect.*, vol. 33, pp. 597-605 and 713-719; Nov./Dec., 1953.) Systems with nonrotational symmetry are considered, such as those used for producing ribbon beams. The method of conformal representation is used and formulae are derived based on purely electrostatic conditions; the validity of these formulae for operating conditions is examined.
- 621.385.832:681.142 1263
Recent Advances in Cathode-Ray-Tube Storage—Williams, Kilburn, Litting, Edwards, and Hoffman. (*See* 985.)
- 621.378 1264
Investigation of the use of Caesium Vapour in Thyatron-Type Gas-Filled Valves—R. Coquerel. (*Le Vide*, vol. 8, pp. 1384-1391; July/Sept., 1953.)
- 621.387:621.318.57 1265
A New Cold-Cathode Decade Counter Tube—H. v. Gugelberg. (*Helv. Phys. Acta*, vol. 26, pp. 586-588; Nov. 16, 1953. In German.) Counting rates up to 10⁶ pulses/second have been obtained with experimental tubes using asymmetrical molybdenum cathodes.
- 621.387:621.318.572 1266
Cold-Cathode Tubes for Transmission of Audio-Frequency Signals—M. A. Townsend and W. A. Depp. (*Bell. Sys. Tech. Jour.*, vol. 32, pp. 1371-1391; Nov., 1953.) The desirable transmission properties are discussed of tubes for use as switching elements in series with telephone circuits; performance curves for an experimental diode are given.

MISCELLANEOUS

- 621.39 1267
Some Recent Developments in Electronic Engineering—(*Electronic Eng.*, vol. 26, pp. 20-26; Jan., 1954.) Developments discussed include telemetering in guided missiles, radar, and navigation aids and associated equipment for radio communication, equipment for meteorological investigations, computers, and apparatus for electromedical and industrial uses.

BOARD OF
DIRECTORS, 1954

William R. Hewlett
President

M. J. H. Ponte
Vice-President

W. R. G. Baker
Treasurer

Haraden Pratt
Secretary

John R. Pierce
Editor

D. B. Sinclair
Senior Past President

J. W. McRae
Junior Past President

•

1954

A. N. Goldsmith
J. T. Henderson (R8)
A. V. Loughren
C. A. Priest (R4)
J. R. Ragazzini (R2)
J. D. Ryder
A. W. Straiton (R6)]
J. A. Stratton
Ernst Weber

•

1954-1955

S. L. Bailey
C. J. Marshall (R5)
L. E. Packard (R1)
J. M. Pettit (R7)
B. E. Shackelford
H. W. Wells (R3)

•

1954-1956

A. G. Jensen
George Rappaport

•

George W. Bailey
Executive Secretary

•

John B. Buckley
Chief Accountant

Laurence G. Cumming
Technical Secretary

Evelyn Davis
*Assistant to the
Executive Secretary*

Emily Sirjane
Office Manager

TRANSACTIONS OF THE I.R.E.

Published by
The Professional Groups of
The Institute of Radio Engineers, Inc.

1953 INDEX

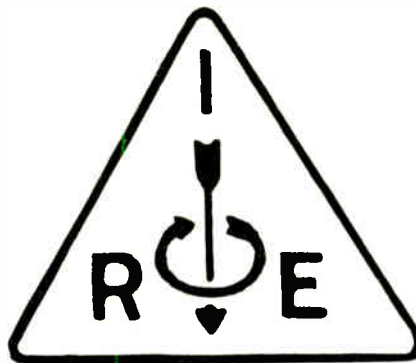

Aeronautical and Navigational Electronics
Antennas and Propagation
Audio
Broadcast and Television Receivers
Circuit Theory
Communications Systems
Electron Devices

Electronic Computers
Industrial Electronics
Information Theory
Instrumentation
Medical Electronics
Microwave Theory and Techniques
Quality Control
Vehicular Communications

Editorial Department

John R. Pierce, Editor

E. K. Gannett
Managing Editor

Marita D. Sands
Assistant Editor

The Institute of Radio Engineers, Inc.
1 East 79 Street
New York 21, N.Y.

Copyright, 1954, by The Institute of Radio Engineers, Inc.

TABLE OF CONTENTS

General Information	Cover II	Professional Group on Electronic Computers	Page 8
Combined Index to Authors	Page 3	Contents	" 8
Professional Group on Aeronautical and Navi- gational Electronics	" 4	Index to Subjects	" 8
Contents	" 4	Professional Group on Industrial Electronics	" 8
Index to Subjects	" 4	Contents	" 8
Professional Group on Antennas and Propaga- tion	" 4	Index to Subjects	" 8
Contents	" 4	Professional Group on Information Theory	" 9
Index to Subjects	" 5	Contents	" 9
Professional Group on Audio	" 5	Index to Subjects	" 9
Contents	" 5	Professional Group on Instrumentation	" 9
Index to Subjects	" 5	Contents	" 9
Professional Group on Broadcast and Television Receivers	" 6	Index to Subjects	" 10
Contents	" 6	Professional Group on Medical Electronics	" 10
Index to Subjects	" 6	Contents	" 10
Professional Group on Circuit Theory	" 7	Index to Subjects	" 10
Contents	" 7	Professional Group on Microwave Theory and Techniques	" 10
Index to Subjects	" 7	Contents	" 10
Professional Group on Communications Systems	" 7	Index to Subjects	" 10
Contents	" 7	Professional Group on Quality Control	" 10
Index to Subjects	" 7	Contents	" 10
Professional Group on Electronic Devices	" 7	Index to Subjects	" 11
Contents	" 7	Professional Group on Vehicular Communica- tions	" 11
Index to Subjects	" 8	Contents	" 11
		Index to Subjects	" 11
		Professional Groups of the IRE	Cover IV

GENERAL INFORMATION

The Institute

The Institute of Radio Engineers serves the radio, allied electronics, and communications fields by presentation of technical material, and the monthly publication of the PROCEEDINGS OF THE I.R.E., a technical journal. The Institute also publishes Standards, Professional Group publications and a Convention Record.

Membership has grown since 1912 to more than 37,000 in 1954. Grades of membership depend on the applicant's qualifications, with dues ranging from \$5.00 per year for Students to \$15.00 per year for Members, Senior Members, Fellows, and Associates of more than five years' standing.

PROFESSIONAL GROUPS

To fully serve the I.R.E. membership, Professional Groups have been formed in 21 specialized technical fields, with membership open only to I.R.E. members.

Group activities include the sponsoring of symposia and conferences, and the publication of TRANSACTIONS OF THE I.R.E., journals containing technical material of special interest to members. To support activities, assessment fees may be levied by Groups on members.

The PROCEEDINGS

The PROCEEDINGS has been published without inter-

ruption since 1913. Over 4,900 technical contributions have appeared in its pages, portraying a written history of developments in both theory and practice. Contents of papers are the author's responsibility and are not binding on the Institute or members. All rights of republication are reserved by the Institute.

Annual subscription rates in United States, its possessions, and Canada, \$18.00; to college and public libraries ordering direct, \$13.50; other countries, add \$1.00 for postage.

The TRANSACTIONS

TRANSACTIONS have been published at intervals by Professional Groups since December, 1951. More than 500 specialized technical papers have been made available to Group members to date. All papers published in the TRANSACTIONS are procured and reviewed by the respective Professional Group. Contents of papers are the responsibility of the authors and not binding on the Institute, the Groups, or their members. All rights of republication are reserved by the Institute. The TRANSACTIONS are sent gratis to paid Group members.

Subscription rates covering all issues of TRANSACTIONS published during the twelve-month period starting July 1, 1952, for the United States, its possessions, and Canada, \$100; to colleges and public libraries, \$75.

Combined Index to Authors

Code numbers refer to papers as given in the contents list for each Professional Group. The letters in the code number designate the particular Professional Group, as follows:

- | | |
|---|--------------------------------------|
| AE: Aeronautical and Navigational Electronics | EC: Electronic Computers |
| AP: Antennas and Propagation | IE: Industrial Electronics |
| A: Audio | IT: Information Theory |
| BTR: Broadcast and Television Receivers | I: Instrumentation |
| CT: Circuit Theory | ME: Medical Electronics |
| CS: Communication Systems | MTT: Microwave Theory and Techniques |
| ED: Electron Devices | QC: Quality Control |
| | VC: Vehicular Communications |

A

Anderson, J. R.: EC13
Anderson, L. J.: A34
Anderson, R. L.: ED9
Anderson, W. P.: IT24
Archer, D. H.: AP103
Atherton, J. F.: IT35
Auerbach, I. L.: EC14

B

Bailey, O. E.: IT28
Baker, W. R. G.: VC24
Ballard, C. P.: I-18
Barker, R. H.: IT35
Bartlett, M.S.: IT8, IT26, IT27, IT28, IT35, IT36
Baruch, J. J.: A35
Bass, L.: QC7
Bates, J. A. V.: IT2, IT18, IT32
Bauer, B. B.: A44, A53
Biltz, F. J.: AE17
Bixler, O. C.: A36
Black, K. C.: AE10, AE15
Blanchard, R. L.: CT10
Bleazey, J. C.: A47
Bolljahn, J. T.: AP108
Boothroyd, W. P.: BTR5
Bowen, A. F.: I-12
Bradley, W. E.: CT11
Brangaccio, D. L.: ED13
Bridges, J. M.: IE2
Brown, A. S.: AE16
Bryan, F. E.: I-16
Bryant, J. H.: MTT18
Budelman, F. T.: VC19
Buff, C.: CS9
Bullington, K.: VC20
Burgess, R. E.: IT29
Burrows, C. E.: AP109

C

Cahn, L.: EC22
Caldwell, J. J., Jr.: ED17
Calpine, H. C.: IT33, IT35
Carnes, W. T., Jr.: AE24
Chait, H. N.: MTT14
Cherry, E. C.: IT4, IT23, IT24
Ciccolella, D. F.: VC30
Coggeshall, I. S.: CS2
Cohn, M.: MTT19
Collins, A. A.: CS1
Cotecchia, I-9
Craft, L. M.: CS4
Craig, L. J.: EC15
Crain, M.: AP107
Crosby, D. R.: MTT10
Crosby, M. G.: CS6
Cutler, C. C.: ED13

D

Deschamps, G.: MTT1, MTT20
Dettinger, D.: MTT11
Dickey, F. R., Jr.: AE14
Dishal, M.: VC29
Dombrowski, G. E.: ED21

E

Elbourn, R. D.: EC10
Enestein, N. H.: ED12, ED19
Engelmann, H. F.: MTT6
Engstrom, J. R.: IE6
Eshleman, V. R.: AP106

F

Fairthorne, R. A.: IT33
Farr, L. E., Jr.: IE6
Feingold, W.: BTR15
Fleisher, H.: ED10
Fox, A. G.: MTT5
Frank, E.: ME2
Fritz, E.: AE22
Fry, D. B.: IT13

G

Gabor, D.: IT1, IT6, IT25
Gardner, F. M.: A55
Gold, T.: IT14, IT30
Good, I. J.: IT23, IT24, IT25, IT26, IT27, IT29, IT34, IT35, IT36
Good, W. E.: BTR14
Green, E. E.: I-7
Grivet, P.: IT29

H

Hadge, E.: MTT9
Haneman, V. S.: I-9
Hanks, H. C., Jr.: MTT4
Hart, B.: CS10
Hassell, P. A.: IE3
Heitner, A. J.: QC10
Heller, D. M.: VC21
Henry, E. G.: IE1
Hergenrother, R. C.: ED7
Herrick, G. Q.: CS5
Hershberger, W. D.: MTT13
Heuer, C. H.: BTR9
Hick, W. E.: IT16, IT31
Hinkelman, T. D.: EC17
Hirsch, C. J.: BTR2
Hoffman, W. C.: AP105
Hok, G.: ED22
Hollis, J. L.: A40
Hollmann, H. E.: ME1
Horn, L. H.: BTR3
Howe, C. H.: EC20
Howe, R. M.: EC20
Hulst, G. D.: BTR6
Hunter, L. P.: ED10
Huskey, H. D.: EC18, EC24

I

Irish, C. G.: ED10
Israel, D. D.: BTR4, BTR12

J

Jaffe, L.: I-8
Johnson, H. R.: ED7, ED16

K

Kaminsky, L. M. BTR10

Kell, R. D.: BTR8
Kent, E. L.: A37
Kirkpatrick, G. M.: AE18
Klein, R. J.: EC21
Klipsch, P. W.: A43
Korewick, J.: MTT3, MTT20
Kraus, M.: EC17
Kreck, J. A.: CS7
Kron, G.: CT14

L

Labrie, L. J.: VC30
Lang, H. C.: A35
Lawrence, W.: IT24
Lee, F. B.: AE9
Lee, L. K.: BTR7
Leite, I-9
Lennert, F.: A39
Libaw, W. H.: EC15
Loughlin, B. D.: BTR2
Lund, G. W.: I-11

M

MacDonald, D. K. C.: IT12, IT25, IT29, IT34
Mackey, R. C.: MTT13
MacKay, D. M.: IT3, IT7, IT22, IT26, IT28, IT33, IT36
Margerum, D. L.: MTT16
McDermott, J.: QC7
McMahon, M. E.: ED12
Medill, J.: A54
Mergler, H. W.: IE5
Meyer, A.: A52
Meyer, S.: EC23
Mihran, T. G.: ED8
Miller, S. E.: MTT2
Moe, R. E.: QC11
Moran, P. A.: IT26, IT27
Morita, T.: MTT15
Morrow, C. H.: AE9
Moshos, G. J.: IE5
Moss, S. H.: IT24
Mueller, G. E.: ED18
Murakami, T.: BTR16
Mynall, D. J.: IT35

N

Newton, R. F.: BTR7
Noble, D. E.: VC27

O

Olsen, V. O.: AE21
Olson, H. F.: A47, A51

P

Page, R. M.: CS3
Papoulis, A.: CT16
Parmet, B. S.: BTR10
Parsegian, V. L.: IE4
Paivinen, J. O.: EC14
Peeler, G. D. M.: AP103
Percival, W. S.: IT36
Peterson, A.: A49
Pipes, L. A.: CT15

Poritsky, H.: ED10
Prager, H. J.: QC8
Pratt, A.: MTT17
Pratt, H.: VC32
Preston, J.: A47
Prim, R. C.: ED15
Pritchard, D. H.: BTR13

Q, R

Raabe, H. P.: MTT12
Rauch, L. L.: I-9
Reese, R. F.: AP108
Reeves, A. H.: IT26
Rennick, J. L.: BTR9
Rhead, K. J.: AE13
Rhodes, R. N.: BTR13
Riblet, H. J.: MTT7
Riddle, J.: AE9
Robbins, R. L.: AP101
Roberts, F.: IT28, IT32
Rochester, N.: EC11, EC19
Rosen, L.: I-15
Rosenman, L.: A41
Rowe, H. E.: ED8
Rowe, J. E.: ED20
Rudenberg, H. G. ED7
Rushton, W. A. H.: IT15
Rust, W. M., Jr.: VC22

S

Saad, T. S.: MTT8
Sabine, H. J.: A46
Saint, S. P.: AE9
Sakiotis, N. G.: MTT14
Salmon, V.: A45
Sandretto, P. C.: AE19
Savidge, D. V.: I-6
Scarborough, A. D.: EC16
Schouten, J. F.: IT33
Schroeder, A. C.: BTR8
Scott, R. E.: CT10
Shephard, N. H.: VC26
Sherer, L. M.: AE9
Shannon, C. E.: IT5, IT9, IT10, IT24
Sheingold, L. S.: MTT15
Shockley, W.: ED15
Silver, S.: AP111
Simmons, D. J.: I-17
Sinclair, G.: AP110
Singer, E. N.: VC31
Sink, R. L.: I-10
Slater, E.: IT20, IT34
Slaymaker, F. H.: A48
Slocomb, G. M.: I-10
Smith, B. D.: AE23
Smith, J. E.: CS8
Snyder, W.: AP104
Steinberg, J. L.: IT29
Steward, J. L.: CT12
Straiton, A. W.: AP107
Strauss, H. E.: VC25
Stover, J. S.: VC23
Stumpers, F. L.: IT34, IT37

Continued on page 4

Combined Index to Authors

T
 Tinkham, R. J.: A56
 Turing, A. M.: IT33, IT34
 Tuttle, D. F., JR.: CT9

U, V
 Uttley, A. M.: IT19, IT24, IT33
 Van der Ziehl, A.: ED9
 Van der Pohl, B.: IT23, IT25,
 IT30, IT33
 Van Soest, J. L.: IT36

Veneklasen, P. S.: A50
 Von Rosenberg, C. E.: AP107

W
 Wagner, H. M.: ED6
 Wait, J. R.: AP102
 Walter, W. G.: IT17
 Walters, L. G.: EC12
 Ware, W. H.: EC19, I-13
 Waring, J.: BTR5
 Weber, J.: ED11

Weber, P. J.: A42
 Weinberg, L.: CT13
 Wengenroth, R. D.: MTT11
 Westcott, J. H.: IT21, IT35
 Whinnery, J. R.: ED7
 White, E. J.: MTT18
 Wild, J. J.: I-14
 Wilkinson, J. E.: AE11, AE20,
 AE25
 Williston, R. L.: MTT7
 Wilson, L. D.: EC23
 Wimpy, E. K.: QC9

Winter, A. J.: ED9
 Witt, R. P.: EC10
 Woodward, P. M.: IT11, IT23,
 IT28

X, Y, Z
 Yeh, C.: A38
 Young, A. E.: IE5
 Young, W. R., Jr.: VC28
 Zane, J.: AP112
 Zeidler, H. M.: ED10

Professional Group on Aeronautical and Navigational Electronics

Contents

PGAE-7, March, 1953	
TRANSACTIONS OF THE I.R.E.	
<i>Index Number</i>	<i>Page</i>
AE9	Symposium on Electronics and the Airlines..... 1
PGAE-8, June 1953	
TRANSACTIONS OF THE I.R.E.	
AE10	A Report from the Chairman, K. C. Black..... 1
AE11	Memorandum from the Editor, John E. Wilkinson.... 3
AE12	Classified Symposium on Airborne Electronics..... 4
AE13	A Discussion of United Air Lines, VHF Network Development, K. J. Rhead... 9
AE14	Theoretical Performance of Airborne Moving Target Indicators, Frank R. Dickey, Jr..... 12

PGAE-9, September, 1953
 TRANSACTIONS OF THE I.R.E.

<i>Index Number</i>	<i>Page</i>
AE15	A Report from the Chairman, K. C. Black..... 1
AE16	Reliability of Airborne Electronic Equipment and Our Ability to Maintain it for War, A. S. Brown..... 3
AE17	Automatic Impedance—Matching Unit for Liaison Radio Flush Mounted Aircraft Antenna, Francis J. Blitz..... 10
AE18	Aperture Illuminations for Radar Angle-of-Arrival Measurements, G. M. Kirkpatrick..... 20

PGAE-10, December, 1953

TRANSACTIONS OF THE I.R.E.	
AE19	Engineering Judgment and Technical Honesty, P. C. Sandretto..... 1
AE20	Special Announcement, John E. Wilkinson..... 3
AE21	A Design Procedure for Subminiature Electronic Assemblies, Vernon O. Olsen. 4

<i>Index Number</i>	<i>Page</i>
AE22	Information Theory in Air Traffic Control, Edward Fritz..... 16
AE23	Analysis of Commutated Networks, B. D. Smith..... 21
AE24	ARINC Electronic Equipment Planning for the Airline Industry, Wm. T. Carnes, Jr..... 27
AE25	Chapter News, John E. Wilkinson..... 35

Index to Subjects

Airlines Equipment Planning: AE24
Air Traffic Control, Information Theory in: AE22
Antenna, Aircraft: AE17
Common System, Air Navigation and Traffic Control: AE9
Commutated Networks: AE23
Design, Judgment in: AE19
Impedance-Matching Unit: AE17
Moving Target Indicators: AE14
Professional Group Activities: AE10, AE11, AE15, AE20, AE25
Radar Angle-of-Arrival Measurements: AE18
Reliability of Airborne Electronic Equipment: AE16
Subminiature Assembly Design: AE21
Symposium on Airborne Electronics: AE12
VHF Network, United Air Lines: AE13

Professional Group on Antennas and Propagation

Contents

Vol. AP-1, No. 1, July, 1953	
TRANSACTIONS OF THE I.R.E.	
<i>Index Number</i>	<i>Page</i>
AP101	Measurement of Path Loss between Miami and Key West at 3675 MC, R. L. Robbins..... 5
AP102	Radiation from a Vertical Electric Dipole over a Strat-

<i>Index Number</i>	<i>Page</i>
AP103	ified Ground, James R. Wait..... 9
AP104	A Two-Dimensional Microwave Luneberg Lens, G. D. M. Peeler and D. H. Archer..... 12
AP105	The Effect of Ions on Magneto Ionic Characteristics, William Snyder..... 23
	Symposium on Tropospheric Wave Propagation within the Horizon, W. C. Hoffman 28

Vol. AP-1, No. 2, October, 1953

TRANSACTIONS OF THE I.R.E.	
<i>Index Number</i>	<i>Page</i>
AP106	The Effect of Radar Wavelength on Meteor Echo Rate, Von R. Eshleman... 37
AP107	A Statistical Survey of Atmospheric Index-of-Refraction Variation, C. M. Crain, A. W. Straiton and C. E. von Rosenberg..... 43

Continued on page 5

<i>Index Number</i>		<i>Page</i>
AP108	Electrically Small Antennas and the Low-Frequency Aircraft Antenna Problem, <i>J. T. Bolljahn and R. F. Reese</i>	46
AP109	Reports of the Tenth URSI General Assembly, Sidney, Australia, August 11-26, 1952, <i>Charles R. Burrows</i> ..	55
AP110	Symposium on Microwave Optics Held at McGill University, Montreal, June 22-25, 1953, <i>George Sinclair</i> ..	58
AP111	Sessions on Diffraction and Electromagnetic Theory, <i>Samuel Silver</i>	58
AP112	Preparation of Technical Illustrations for Publication, <i>John Zane</i>	60

Index to Subjects

Aircraft Antennas: AP108
Low-Frequency: AP108
Antennas: AP108
Electrically Small: AP108
Low-Frequency, Aircraft: AP108
Dipole Radiation over Stratified Ground: AP102
Fading at 3675: AP101
Index of Refraction: AP107
Survey of Variation: AP107

Ions: AP104
Effect on Polarization in E Layer: AP104
Lens, Luneberg: AP103
Two-Dimensional Model: AP103
Magneto-Ionic Polarization: AP104
Effect of Ions in E Layer: AP104
Meteor Echo Rate: AP106
Effect of Radar Wavelength: AP106
Polarization: AP104
Effect of Ions in E Layer: AP104
Radiation: AP102
Vertical Dipole over Stratified Ground: AP102
Refraction Index Variation, Survey of: AP107
Transmission Loss at 3675 Mc: AP101

Nontechnical Index

Meetings

Conference Radio Meteorology, Austin, Tex., Nov. 9-12; July, p. 4; October, pp. 34-35
Western Electronic Show and Convention, San Francisco, Calif., Aug. 19-21, July, p. 4
URSI Spring Meeting, Washington, D. C., April 27-30, July, p. 4
URSI Fall Meeting, Ottawa, Canada, October 5-8, July, p. 4; October, p. 35
Symposium on Tropospheric Wave Propagation Within the Horizon, U. S. Navy

Electronics Lab., March 30-April 2, July, pp. 28-30
Tenth URSI General Assembly, Sidney, Australia, Aug. 11-24, 1952, October, pp. 55-57
Symposium on Microwave Optics Montreal, Canada, June 22-25, October, pp. 58-60

Miscellaneous

Antennas and Waveguide Definitions: October, pp. 33-34
Preparation of Technical Illustrations for Publication: October, pp. 60-62

Personals

Jansky and Bailey: October, p. 36
Van Atta, L. C.: October, p. 36
Brown, J. S.: October, p. 36
Krahe, L. R.: October, p. 36
Scheldoy, M. W.: October, p. 36

Professional Group News

Administrative Committee: July, p. 2; October, p. 34
Chapter News: July, p. 2-3; October, pp. 34-35
Name: July, p. 1
Officers: July, p. 2; October, p. 34
TRANSACTIONS: July, pp. 1-2; October, p. 33

Professional Group on Audio

Contents

Vol. AU-1, No. 1, January-February, 1953

TRANSACTIONS OF THE I.R.E.

<i>Index Number</i>		<i>Page</i>
A34	Sensitivity of Microphones to Stray Magnetic Fields, <i>L. J. Anderson</i>	1
A35	An Analogue for Use in Loudspeaker Design Work, <i>Jordan J. Baruch and Henry C. Lang</i>	8
A36	A Practical Binaural Recording System, <i>Otto C. Bixler</i>	14

Vol. AU-1, No. 2, March-April, 1953

TRANSACTIONS OF THE I.R.E.

A37	Electronic Music—Past, Present and Future, <i>Earle L. Kent</i>	1
A38	Analysis of a Single-Ended-Push-Pull Audio Amplifier, <i>Chai Yeh</i>	9
A39	Equalization of Magnetic Tape Recorders for Audio and Instrumentation Applications, <i>Frank Lennert</i>	20
A40	Why Fight Grid Current in Class B Modulators? <i>J. L. Hollis</i>	26
A41	Microphone Sensitivity Conversion Chart, <i>Leo Rosenman</i>	33

Vol. AU-1, No. 3, May-June, 1953

TRANSACTIONS OF THE I.R.E.

<i>Index Number</i>		<i>Page</i>
A42	Status of Military Research and Development in Acoustics and Audio, <i>Paul J. Weber</i>	4
A43	Loudspeaker Developments, <i>Paul W. Klipsch</i>	16
A44	Acoustic Damping for Loudspeakers, <i>Benjamin B. Bauer</i>	23

Vol. AU-1, No. 4, July-August, 1953

TRANSACTIONS OF THE I.R.E.

A45	Loudspeaker Impedance, <i>Vincent Salmon</i>	1
A46	Room Acoustics, <i>Hale J. Sabine</i>	4
A47	The Uniaxial Microphone, <i>Harry F. Olson, John Preston, and John C. Bleazey</i> ..	12

Vol. AU-1, No. 5, September-October, 1953

TRANSACTIONS OF THE I.R.E.

A48	RTMA SE-8 Committee on High Fidelity, <i>Frank H. Slaymaker</i>	3
A49	Technical Committee Work on Audio-Frequency Measurements, <i>Arnold Peterson</i> ..	4

<i>Index Number</i>		<i>Page</i>
A50	Power Capacity of Loudspeakers, <i>Paul S. Veneklasen</i>	5
A51	Subjective Loudspeaker Testing, <i>Harry F. Olson</i>	7
A52	Air-Core Coil Design for Crossover Networks, <i>Albert Meyer</i>	9

Vol. AU-1, No. 6, November-December, 1953

TRANSACTIONS OF THE I.R.E.

A53	A Miniature Microphone for Transistorized Amplifiers, <i>B. B. Bauer</i>	5
A54	A Miniature Piezoelectric Microphone, <i>John Medill</i>	7
A55	A Low Frequency Selective Amplifier, <i>Floyd M. Gardner</i>	10
A56	Stereophonic Recording Equipment, <i>Russell J. Tinkham</i>	13

Index to Subjects

Acoustics: A42, A46
Military Research: A42
Room: A46
Air-Core Coil Design: A52
<i>Continued on page 6</i>

Amplifier, Audio: A38, A40, A55
 Grid Voltage Waveform Distortion: A40
 Low-Frequency, Selective: A55
 Single-Ended Push-Pull: A38
 Binaural Recording System: A36
 Electronic Music: A37
 Grid Voltage Waveform Distortion in Class
 B Modulators: A40
 Loudspeakers: A35, A43, A44, A45, A50,
 A51
 Acoustic Damping: A44
 Analogue for Design of: A35
 Developments: A43
 Impedance: A45
 Power Capacity: A50
 Subjective Testing: A51
 Magnetic Recording: A39
 Equalization of Recorders: A39
 Microphones: A34, A41, A47, A53, A54
 Miniature: A53, A54
 Sensitivity Conversion Chart: A41
 Sensitivity to Stray Magnetic Fields: A34
 Uniaxial: A47
 Recording: A36, A39, A56
 Binaural: A36
 Magnetic: A39
 Equalization of Recorders: A39
 Stereophonic Equipment: A56
 Standards: A48, A49
 Audio-Frequency Measurements, IRE:
 A49
 High Fidelity, RTMA: A48
 Stereophonic Recording Equipment: A56

Nontechnical Index

Committees

Administrative: AU-1, 6, p. 3
 Appointments: AU-1, 4, p. 3
 Awards, AU-1, 5, p. 2
 Editorial: AU-1, 3, p. 2
 Nominations: AU-1, 5, p. 2
 Papers Procurement: AU-1, 6, p. 3
 Program: AU-1, 6, p. 3
 Tapescripts: AU-1, 2, p. 8; AU-1, 5, p. 2;
 AU-1, 6, p. 4
 Ways and Means: AU-1, 5, p. 3

Editorials

Camras, M.
 Report to PGA: AU-1, 3, p. 1
 Martin, D. W.
 Editorial Committee Reorganization:
 AU-1, 3, p. 2

Meetings

Acoustical Society of America: AU-1, 5, p. 3
 IRE National Convention: AU-1, 6, p. 4
 International Meeting on Sound Recording:
 AU-1, 6, p. 4
 Magnetic Recording Symposium: AU-1, 5,
 p. 3
 National Electronics Conference: AU-1, 4,
 p. 3; AU-1, 5, p. 2
 Noise Abatement Symposium: AU-1, 5, p. 2

Philadelphia Symposium on Audio: AU-1, 5,
 p. 1
 Seminar on Acoustics for Radio Engineers:
 AU-1, 1, p. 23
 Southwestern IRE Conference: AU-1, 2, p. 6
 Western Convention and Electronic Show:
 AU-1, 5, p. 2

Miscellaneous

Cumulative Index, 1951-1953: AU-1, 6, p.
 16
 IRE-PGA Questionnaire Data: AU-1, 6, p. 1
 Report of Secretary-Treasurer: AU-1, 1, p.
 24; AU-1, 2, p. 7
 Report on Study of Concurrent Member-
 ship: AU-1, 6, p. 1
 Survey of Transactions Reader Interest:
 AU-1, 6, p. 2

PGA Chapters

Chicago: AU-1, 1, p. 7; AU-1, 5, p. 2; AU-1,
 6, p. 4
 Cincinnati: AU-1, 3, p. 3
 Current List: AU-1, 4, p. 3
 Dayton: AU-1, 6, p. 4
 Houston: AU-1, 4, p. 3; AU-1, 5, p. 2; AU-1,
 6, p. 4
 San Diego: AU-1, 4, p. 3

PGA People

Bixler, O. D.: AU-1, 1, p. 24

Professional Group on Broadcast and Television Receivers

Contents

PGBTR-2, March, 1953

TRANSACTIONS OF THE I.R.E.

<i>Index Number</i>		<i>Page</i>
BTR2	General Color-Receiver Design Considerations, <i>Charles J. Hirsch and Bernard D. Loughlin</i>	3
BTR3	Connection of UHF and Color Adaptors to UHF Receivers, <i>Leonard H. Horn</i>	17

PGBTR-3, June, 1953

TRANSACTIONS OF THE I.R.E.

BTR4	A Four-Point Message of Importance to All Members of the IRE Professional Group on Broadcast and Television Receivers, <i>Dorman D. Israel</i>	1
BTR5	The Selection and Amplification of UHF Television Signals, <i>Wilson P. Boothroyd and John Waring</i> ...	5
BTR6	The Design of Television Receivers Utilizing Non-Synchronous Power, <i>George D. Hulst</i>	15

Transactions Index—6

<i>Index Number</i>		<i>Page</i>	<i>Index Number</i>		<i>Page</i>
BTR7	Approach to Mechanized Assembly of Electronic Equipment Applicable to TV Receivers, <i>R. F. Newton and L. K. Lee</i>	25	BTR15	Color Television—A Primer on the NTSC System, <i>William Feingold</i>	30
BTR8	Optimum Utilization of the Radio Frequency Channel for Color Television, <i>R. D. Kell and A. C. Schroeder</i> ..	33	BTR16	A VHF-UHF Television Turret Tuner, <i>T. Murakami</i> ..	38
BTR9	A Four-Gun Tube for Color Television Receivers, <i>John L. Rennick and Charles H. Heur</i>	40			
BTR10	Transient Considerations in the NTSC Color System, <i>Bernard S. Parmet and Leonard M. Kaminsky</i>	47			
	PGBTR-4, October, 1953				
	TRANSACTIONS OF THE I.R.E.				
BTR11	Suggested Professional Group Emblem				
BTR12	The Toronto Convention, <i>Dorman D. Israel</i>	i			
BTR13	Color Signal Demodulators, <i>D. H. Pritchard and R. N. Rhodes</i>	1			
BTR14	Color Synchronization, <i>William E. Good</i>	23			
	Index to Subjects				
	Adaptors for UHF and Color Receivers: BTR3				
	Amplification of UHF Television Signals: BTR5				
	Color Television: BTR3, BTR8, BTR9, BTR10, BTR13, BTR14, BTR15				
	Four-Gun Tube: BTR9				
	NTSC System: BTR15				
	Optimum Utilization of RF Channel: BTR8				
	Receiver Design: BTR3				
	Signal Demodulators: BTR13				
	Synchronization: BTR14				
	Transient Considerations: BTR10				
	Mechanized Assembly: BTR7				
	Professional Group Activities: BTR4, BTR-11, BTR12				
	Selection of UHF Television Signals: BTR5				
	Television Receivers Using Nonsynchronous Power: BTR6				
	Turret Tuner, VHF-UHF: BTR16				

Professional Group on Circuit Theory

Contents

PGCT-2, December, 1953

TRANSACTIONS OF THE I.R.E.

<i>Index Number</i>		<i>Page</i>
CT8	PGCT Activities	1
CT9	A Problem in Synthesis, <i>D. F. Tuttle, Jr.</i>	6
CT10	An Iterative Method for Network Synthesis, <i>R. E. Scott</i> and <i>R. L. Blanchard</i>	19
CT11	Design of a Simple Band-pass Amplifier with Approximate Ideal Frequency Characteristics, <i>W. E. Bradley</i>	30

<i>Index Number</i>		<i>Page</i>
CT12	Quasi-Distortionless Filter Functions, <i>J. L. Steward</i>	39
CT13	Unbalanced RLC Networks Containing only One Resistance and One Real Transformer, <i>Louis Weinberg</i>	55
CT14	A Method to Solve Very Large Physical Systems in Easy Stages, <i>Gabriel Kron</i>	71
CT15	Matrix Analysis of Linear Time-Varying Circuits, <i>Louis A. Pipes</i>	91
CT16	Correspondence: Foster's Reactance Theorem, <i>A. Papoulis</i>	106

Index to Subjects

Amplifier: CT11
Band-Pass Design: CT11
Foster-Reactance Theorem: CT16
Linear Time-Varying Circuit Analysis: CT15
Professional Group Activities: CT8
Quasi-Distortionless Filter Functions: CT12
Solving Large Physical Systems: CT14
Synthesis: CT9, CT10
General: CT9
Iterative Method: CT10
Unbalanced RLC Networks: CT13

Professional Group on Communications Systems

Contents

Vol. CS-1, No. 1, July, 1953

TRANSACTIONS OF THE I.R.E.

<i>Index Number</i>		<i>Page</i>
CS1	Keynote Address, <i>Arthur A. Collins</i>	1
CS2	The Transmission of Intelligence in Typescript, <i>I. S. Coggeshall</i>	4
CS3	Comparative Study of Modulation Methods, <i>R. M. Page</i>	13
CS4	Design Trends in Communication Equipment, <i>L. Morgan Craft</i>	22
CS5	Voice of America and the	

<i>Index Number</i>		<i>Page</i>
	Electromagnetic War, <i>George Q. Herrick</i>	31
CS6	Long-Range Communication Trends, <i>Murray G. Crosby</i>	41
CS7	Aspects of Naval Communications Systems, <i>Joseph A. Krcek</i>	54
CS8	Manufacturers' Contributions to Military Communications, <i>J. Ernest Smith</i>	59
CS9	Twinplex, Twinmode, and Polyplex Radiotelegraph Systems, <i>Christopher Buff</i>	65
CS10	Transmitting Antennas at Mackay Radio Brentwood Station, <i>B. Hart</i>	66
CS11	Constitution and By-Laws	68

Index to Subjects

Antennas, Transmitting, at Brentwood: CS10
Communication Problems: CS1
Design Trends: CS4
Long-Range Communication Trends: CS6
Military Communications, Contributions of Manufacturers: CS8
Modulation Methods, Comparison: CS3
Naval Communication Systems: CS7
Professional Group Constitution and By-laws: CS11
Radiotelegraph, Twinplex, Twinmode and Polyplex: CS9
Transmission of Intelligence in Typescript: CS2
Voice of America: CS5

Professional Group on Electronic Devices

Contents

PGED-2, January, 1953

TRANSACTIONS OF THE I.R.E.

<i>Index Number</i>		<i>Page</i>
ED6	Transistor Characteristics, <i>H. M. Zeidler</i>	2
ED7	Traveling-Wave Tube Oscillators, <i>H. R. Johnson</i> and <i>J. R. Whinnery</i>	11
ED8	Noise Analysis of a Single-Velocity Electron Gun of Finite Cross Section in an Infinite Magnetic Field, <i>H. E. Rowe</i>	36
ED9	The Effect of Filament Voltage Upon Vacuum Tube Characteristics, <i>A. J. Winter</i>	47
ED10	Electron Gas Equations for Electron Flow in Diodes, <i>H. Poritsky</i>	60

PGED-3, June, 1953

TRANSACTIONS OF THE I.R.E.

<i>Index Number</i>		<i>Page</i>
ED11	Amplification of Microwave Radiation by Substances Not in Thermal Equilibrium, <i>J. Weber</i>	1
ED12	Pulse Response of Junction Transistors, <i>Norman H. Enenstein</i> and <i>Morgan E. McMahon</i>	5
ED13	Factors Affecting Traveling-Wave Tube Power Capacity, <i>C. C. Cutler</i> and <i>D. J. Brangaccio</i>	9
ED14	Correction	24

PGED-4, December, 1953

TRANSACTIONS OF THE I.R.E.

<i>Index Number</i>		<i>Page</i>
ED15	Joining Solutions at the Pinch-Off Point in "Field-Effect" Transistor, <i>R. C. Prim</i> and <i>W. Shockley</i>	1
ED16	A Wide-Band Power Mixer Tube, <i>Horace R. Johnson</i>	15
ED17	High Power Traveling-Wave Tube Gain and Saturation Characteristics as a Function of Attenuator Configuration and Resistivity, <i>J. J. Caldwell</i>	28
ED18	A Hollow Beam Cathode, <i>G. E. Mueller</i>	33
ED19	A Transient Equivalent Circuit for Junction Transistors, <i>N. H. Enenstein</i>	37

Continued on page 8

Transactions Index—7

<i>Index Number</i>		<i>Page</i>
ED20	A Wide-Band Structure for High-Power Traveling-Wave Tubes (ABSTRACT), <i>Joseph E. Rowe</i>	55
ED21	Study of RF Cathode Unbalance in Zero-Order Interdigital Magnetrons (ABSTRACTS), <i>G. E. Dombrowski</i>	56
ED22	Theoretical Study of the Initiation of Oscillations in Electron Streams Through Crossed Fields (ABSTRACT), <i>Gunnar Hok</i>	57
ED23	Index	59

Index to Subjects

Amplification of Microwaves by Thermal Unequilibrium: ED16
Beam Loading, Secondary Electron: ED8
Cathode, Hollow Beam: ED23
Diodes, Equations for Electron Flow: ED15
Electron Gun Noise Analysis: ED13
Filament Voltage Effect on Tube Characteristics: ED14
Gas Equations for Diode Electron Flow: ED15
Gas, Pulse Distortion Effects of: ED6
Magnetrons, R-F Cathode Unbalance: ED-26
Mixer Tube, Wideband Power: ED21
Oscillations in Electron Streams: ED27
Oscillators, Traveling-Wave Tube: ED12, ED19

Oscilloscope for 100 KV Pulses: ED7
P-N Junctions, Shot Effect: ED9
Secondary Electron Beam Loading: ED8
Transistors: ED9, ED10, ED11, ED17, ED20, ED24
Characteristics: ED11
"Field Effect," Pinch-Off Point: ED19
Pulse Response: ED17
Short Effect of P-N Junctions: ED9
Temperature Dependence of: ED10
Transient Equivalent Circuit: ED24
Traveling-Wave Tubes: ED12, ED18, ED-19, ED22, ED25
Gain and Saturation Characteristics: ED-22
Oscillators: ED12, ED19
Power Capacity: ED18
Wide-Band Structure for High-Power: ED-25

Professional Group on Electronic Computers

Contents

Vol. EC-2, No. 1, March, 1953

TRANSACTIONS OF THE I.R.E.

<i>Index Number</i>		<i>Page</i>
EC10	Dynamic Circuit Techniques used in SEAC and DYSEAC, <i>R. D. Elbourn and R. P. Witt</i>	2
EC11	Symbolic Programming, <i>Nathaniel Rochester</i>	10

Vol. EC-2, No. 2, June, 1953

TRANSACTIONS OF THE I.R.E.

EC12	Hidden Regenerative Loops in Electronic Analog Computers, <i>Louis G. Walters</i>	1
EC13	Electrical Delay Lines for Digital Computer Applications, <i>J. R. Anderson</i>	5
EC14	Design of Triode Flip-Flops for Long-Term Stability, <i>John O. Paivinen and Isaac L. Auerbach</i>	14

Vol. EC-2, No. 3, September, 1953

TRANSACTIONS OF THE I.R.E.

<i>Index Number</i>		<i>Page</i>
EC15	A Photoelectric Decimal-Coded Shaft Digitizer, <i>W. H. Libaw and L. J. Craig</i>	1
EC16	An Analog-to-Digital Converter, <i>A. D. Scarbrough</i>	5
EC17	The Univac Tube Program, <i>T. D. Hinkelman and M. Kraus</i>	8
EC18	Review Section, <i>H. D. Huskey, Ed.</i>	13

Vol. EC-2, No. 4, December, 1953

TRANSACTIONS OF THE I.R.E.

EC19	Computer Definitions (Guest Editorial), <i>N. Rochester and W. H. Ware</i>	2
EC20	Solution of Linear Differential Equations with Variable Coefficients by the Electronic Differential Analyzer, <i>Carl H. Howe and Robert M. Howe</i>	3
EC21	Automatic Beam Current Stabilization for Williams Tube Memories, <i>Rudolph J. Klein</i>	8

Index Number

EC22	Accuracy of an Analog Computer, <i>Lee Cahn</i>	12
EC23	The Model II Unityper, <i>Louis D. Wilson and Saul Meyer</i>	19
EC24	Review Section, <i>H. D. Huskey, Ed.</i>	29

Index to Subjects

Analog Computer Accuracy: EC22
Analog-to-Digital Converter: EC16
Circuit Techniques in SEAC and DYSEAC: EC10
Definitions: EC19
Delay Lines for Digital Computers: EC13
Differential Analyzer for Equations with Variable Coefficients: EC20
DYSEAC Circuit Techniques: EC10
Flip-Flop Design: EC14
Programming, Symbolic: EC11
Regenerative Loops in Analog Computers: EC12
Review Section: EC18, EC24
SEAC Circuit Techniques: EC10
Shaft Digitizer, Photoelectric: EC15
Unityper, Model II: EC23
UNIVAC Tube Program: EC17
Williams Tube, Beam Current Stabilization: EC21

Professional Group on Industrial Electronics

Contents

PGIE-1, August, 1953

TRANSACTIONS OF THE I.R.E.

<i>Index Number</i>		<i>Page</i>
IE1	Certification of Industrial Heating Equipment, <i>Everett G. Henry</i>	1
IE2	The Role of Electronics in Naval Ordnance, <i>J. M. Bridges</i>	7

Transactions Index—8

Index Number

IE3	Induction Heating Generators as Production Tools in Heat Treating Operations, <i>Peter A. Hassell</i>	11
IE4	Electronics in the Atomic Energy Field, <i>V. L. Parsegian</i>	16
IE5	Machine Tool Control from a Digital-Analog Computer, <i>Harry W. Mergler, George J. Moshos, and Allen E. Young</i>	26
IE6	Electronic Control Circuits in the Mechanical Heart and	

Lung, John R. Engstrom and Leo E. Farr, Jr. 31

Index to Subjects

Atomic Power Reactor, Electronic Equipment for: IE4
Induction Heating Generators: IE3
Industrial Heating Equipment Certification: IE1
Machine Tool Control: IE5
Mechanical Heart and Lung, Control Circuits: IE6
Naval Ordnance, Role of Electronics in: IE2

Professional Group on Information Theory

Contents

PGIT-1, February, 1953

TRANSACTIONS OF THE I.R.E.

<i>Index Number</i>		<i>Index Number</i>	<i>Page</i>
IT1	Communication Theory, Past, Present and Prospective, <i>D. Gabor</i>	IT19	Information, Machines, and Brains, <i>A. M. Uttley</i>
IT2	Glossary of Physiological Terms, <i>J. A. V. Bates</i>	IT20	Statistics for the Chess Computer and the Factor of Mobility, <i>Eliot Slater</i>
IT3	The Nomenclature of Information Theory, <i>D. M. Mackay</i>	IT21	Criteria of Prediction and Discrimination, <i>J. H. Westcott</i>
IT4	A History of the Theory of Information, <i>E. Colin Cherry</i>	IT22	Entropy, Time and Information (Introduction to Discussion), <i>D. M. Mackay</i>
IT5	Communication Theory—Exposition of Fundamentals, <i>C. E. Shannon</i>	IT23	Discussion on Mr. E. C. Cherry's "A History of the Theory of Information".....
IT6	Communication Theory and Physics, <i>D. Gabor</i>	IT24	Discussion on Dr. C. E. Shannon's Papers.....
IT7	Quantal Aspects of Scientific Information, <i>D. M. Mackay</i>	IT25	Discussion on Dr. D. Gabor's Paper, "Communication Theory and Physics".....
IT8	The Statistical Approach to the Analysis of Time-Series, <i>M. S. Bartlett</i>	IT26	Discussion on Mr. D. M. Mackay's Paper "Quantal Aspects of Scientific Information".....
IT9	General Treatment of the Problem of Coding, <i>C. E. Shannon</i>	IT27	Discussion on Professor M. S. Bartlett's Paper "The Statistical Approach to the Analysis of Time-Series".....
IT10	The Lattice Theory of Information, <i>C. E. Shannon</i>	IT28	Discussion on Mr. P. M. Woodward's Paper on "Theory of Radar Information".....
IT11	Theory of Radar Information, <i>P. M. Woodward</i>	IT29	Discussion on Dr. D. K. C. MacDonald's Paper "Fluctuations and the Theory of Noise".....
IT12	Fluctuations and Theory of Noise, <i>D. K. C. MacDonald</i>	IT30	Discussion on Dr. T. Gold's Paper on "Hearing".....
IT13	Communication Theory and Linguistic Theory, <i>D. B. Fry</i>	IT31	Discussion on Dr. W. E. Hick's Paper "Information Theory in Psychology".....
IT14	Hearing, <i>T. Gold</i>	IT32	Discussion on Dr. J. A. V. Bates' Paper "Significance of Information Theory in Neurophysiology".....
IT15	The Problem of the Information which the Brain Receives from the Eye, <i>W. A. H. Rushton</i>	IT33	Discussion on Dr. A. M. Uttley's Paper "Information, Machines and Brains".....
IT16	Information Theory in Psychology, <i>W. E. Hick</i>	IT34	Discussion on Dr. E. Slater's Paper on "Statistics for the Chess Computer and the Factor of Mobility".....
IT17	Possible Features of Brain Function and their Imitation, <i>W. Grey Walter</i>		
IT18	Significance of Information Theory to Neurophysiology, <i>J. A. V. Bates</i>		

<i>Index Number</i>		<i>Page</i>
IT35	Discussion on Dr. J. H. Westcott's Paper "Criteria of Prediction and Discrimination".....	201
IT36	Discussion on Mr. D. M. Mackay's Paper "Entropy, Time and Information"....	206

PGIT-2, November, 1953

TRANSACTIONS OF THE I.R.E.

IT37	A Bibliography of Information Theory Communication Theory—Cybernetics.
------	--

Index to Subjects

Bibliography: IT37
Brain: IT17, IT19, IT33
Compared with Computers: IT19, IT33
Functions: IT17
Chess-Playing Computer: IT20, IT34
Coding: IT9, IT24
Computers: IT19, IT20, IT33, IT34
Chess Playing: IT20, IT34
Compared with Brain: IT19, IT33
Computers Compared with the Brain: IT19, IT33
Entropy: IT22, IT36
Eye, Information Received by Brain From: IT15
Fundamentals: IT5, IT24
Glossary of Terms: IT2
Hearing: IT14, IT30
History: IT1, IT4, IT23
Lattice Theory of Information: IT10, IT24
Linguistic Theory: IT13
Neurophysiology and Information Theory: IT18, IT32
Noise and Fluctuation: IT12, IT29
Nomenclature: IT3
Prediction: IT21, IT35
Psychology, Information Theory Applied to: IT16, IT31
Radar Information: IT11, IT28
Time: IT22, IT36
Time-Series Analysis, Statistical Approach: IT8, IT27

Professional Group on Instrumentation

Contents

PGI-2, June, 1953

TRANSACTIONS OF THE I.R.E.

<i>Index Number</i>		<i>Index Number</i>	<i>Page</i>
I-6	Organization of Data for an Automatic System, <i>D. V. Savidge</i>	I-9	Automatic Reduction of Wind Tunnel Data, <i>Capt. V. S. Haneman, L. L. Rauch, Leite and Cotecchia</i>
I-7	Problems in the Development of an Automatic Data Handling System at NOTS, <i>E. E. Green</i>	I-10	The SADIC, A Precision Analog-Digital Converter, <i>R. L. Sink and G. M. Slocomb</i>
I-8	Progress in Automatic Data Handling at Lewis Flight Propulsion Laboratory of N. A. C. A., <i>L. Jaffe</i>	I-11	E. R. A. Shaft-Position Analog-to-Digital Converter, <i>G. W. Lund</i>
		I-12	A Position Data Measuring System, <i>A. F. Bowen</i>
		I-13	A Binary Outscriber Using Facsimile Paper, <i>W. H. Ware</i>
		I-14	Design Considerations and New Developments in the "Flying Typewriter," <i>J. J. Wild</i>
		I-15	High Speed Printing Equipment, <i>L. Rosen</i>
		I-16	A Complete Telemetry System for the Flight Testing of Aircraft, <i>F. E. Bryan</i> ...
		I-17	A System for Recording Telemetered Data in Digital Form, <i>D. J. Simmons</i>
		I-18	Multi-Channel FM/FM Telemeter Data Handling System, <i>C. P. Ballard</i>

Continued on page 10

Transactions Index—9

Index to Subjects

Analog-to-Digital Converter: I-10, I-11
 SADIC: I-10
 ERA: I-11
 Data Handling System: I-7, I-8, I-18
 FM/FM Telemeter: I-18
 Lewis Flight Propulsion Lab: I-8
 NOTS: I-7

Data Measuring System, Position: I-12
 Data Organization for Automatic System: I-6
 Data Recording: I-17
 Data Reduction, Wind Tunnel: I-9
 ERA Analog-to-Digital Converter: I-11
 Flying Typewriter: I-14
 Outscriber: I-13
 Printing Equipment, High-Speed: I-15

Recording Telemetered Data in Digital Form: I-17
 SADIC Analog-to-Digital Converter: I-10
 Telemetering: I-16, I-17, I-18
 Data Handling System: I-18
 Data Recording: I-17
 Flight Testing: I-16
 Telemetry System for Flight Testing: I-16

Professional Group on Medical Electronics Contents

PGME-1, November, 1953

TRANSACTIONS OF THE I.R.E.

<i>Index Number</i>		<i>Page</i>
ME1	Electrocardiography as a Problem for Modern Engineering, <i>Hans E. Hollman</i>	1

<i>Index Number</i>		<i>Page</i>
ME2	The Zero-Potential Contour on a Homogeneous Conducting Cylinder, <i>Ernest Frank</i>	27

Index to Subjects

Electrocardiography: ME1, ME2
 As an Engineering Problem: ME1
 Cylindrical Representation of Torso: ME
 Zero-Potential Contour on Cylinder: ME2

Professional Group on Microwave Theory and Techniques

Contents

Vol. MTT-1, No. 1, March, 1953

TRANSACTIONS OF THE I.R.E.

<i>Index Number</i>		<i>Page</i>
MTT1	A New Chart for the Solution of Transmission Line and Polarization Problems, <i>Georges Deschamps</i>	5
MTT2	Some Coupled-Wave Theory and Application to Waveguides (Abstract), <i>S. E. Miller</i>	14
MTT3	Audio Modulation Substitution System for Microwave Attenuation Measurements, <i>John Korewick</i>	14
MTT4	The Microwave Interferometer for Measuring the Time Displacement of a Projectile Within the Barrel of a Gun (Abstract), <i>H. C. Hanks, Jr.</i>	22
MTT5	Performance of Ferrites in the Microwave Range (Abstract), <i>A. G. Fox</i>	22
MTT6	Microstrip—A New Microwave Transmission Technique (Abstract), <i>H. F. Engelmann</i>	22
MTT7	X-Band Rotary Joint, <i>H. J. Riblet and R. L. Williston</i>	23
MTT8	Doubly Compensated Tunable Cavity, <i>T. S. Saad</i>	25
MTT9	Compact Top-Wall Hybrid Junction, <i>Eugene Hodge</i>	29

<i>Index Number</i>		<i>Page</i>
MTT10	Duplexing Filter Design at 2000 Mc, <i>D. R. Crosby</i>	31
MTT11	A Standard Waveguide Spark Gap, <i>David Dettinger and R. D. Wengenroth</i>	39
MTT12	A Rotary Joint for Two Microwave Transmission Channels of the Same Frequency Band (Abstract), <i>H. P. Raabe</i>	48

Vol. MTT-1, No. 2, November, 1953

TRANSACTIONS OF THE I.R.E.

MTT13	Instrumentation of Microwave Electron Resonance in Magnetic Fields, <i>R. C. Mackey and W. D. Hershberger</i>	3
MTT14	Properties of Ferrites in Waveguides, <i>N. G. Sakiotis and H. N. Chai</i>	11
MTT15	A Coaxial Magic-T, <i>T. Morita and L. S. Sheingold</i>	17
MTT16	Broad-Banding Circular Polarizing Transducers, <i>D. L. Margerum</i>	24
MTT17	Two Types of Waveguide Switches, <i>Amasa Pratt</i>	30
MTT18	Attenuation and Power-Handling Capability of Helical Radio-Frequency Lines, <i>J. H. Bryant and E. J. White</i>	33

<i>Index Number</i>		<i>Page</i>
MTT19	Annular Resonant Slots in Dielectric Filled Circular Waveguide, <i>Marvin Cohn</i>	39
MTT20	Errata	44

Index to Subjects

Annular Resonant Slots in Waveguide: MTT19
 Attenuation Measurement by Audio Substitution: MTT3, MTT20
 Errata: MTT20
 Cavity, Tunable, Doubly Compensated: MTT8
 Chart for Transmission Line and Polarization Problems: MTT1, MTT20
 Errata: MTT20
 Coaxial Magic T: MTT15
 Coupled-Wave Theory: MTT2
 Duplexing Filter Design: MTT10
 Elliptical Transducer, Broad Band: MTT16
 Ferrite Performance: MTT5, MTT14
 Helical RF Lines, Attenuation: MTT18
 Hybrid Junction, Top-Wall: MTT9
 Interferometer for Projectile Measurements: MTT4
 Magnetic Resonance of Electrons: MTT13
 Magic T, Coaxial: MTT15
 Microstrip: MTT6
 Power Capacity Standard: MTT11
 Rotary Joint: MTT7, MTT12
 Two Channels, Same Frequency: MTT12
 X Band: MTT7
 Spark Gap as a Power Capacity Standard: MTT11
 Spectroscope, Paramagnetic: MTT13
 Waveguide Switches: MTT17

Professional Group on Quality Control

Contents

PGQC-2, March, 1953

TRANSACTIONS OF THE I.R.E.

<i>Index Number</i>		<i>Page</i>
QC7	A Variables Double Sampling Plan, <i>Joseph McDermott</i>	

<i>Index Number</i>		<i>Page</i>
QC8	Performance Evaluation of "Special Red" Tubes, <i>H. J. Prager</i>	8
QC9	Development of Inspection Manual for Reliable Tubes, <i>E. K. Wimpy</i>	22

<i>Index Number</i>		<i>Page</i>
QC10	Adaptation of Industry Proposals to Subminiature Tube Evaluation, <i>A. J. Heitner</i>	29
QC11	An Engineering Progress Report on Reliable Tubes, <i>R. E. Moe</i>	43

Continued on page 11

Transactions Index—10

Index to Subjects

Inspection Manual for Reliable Tubes: QC9
 Sampling Plan, Tolerance: QC7

"Special Red" Tubes, Performance: QC8
 Subminiature Tube Evaluation: QC10
 Tolerance, Sampling Plan: QC7
 Tube Reliability: QC9, QC11

Inspection Manual: QC9
 Progress Report: QC11
 Tubes, "Special Red": QC8
 Variables Double Sampling Plan: QC7

Professional Group on Vehicular Communications

Contents

PGVC-3, June, 1953

TRANSACTIONS OF THE I.R.E.

<i>Index Number</i>	<i>Page</i>	<i>Index Number</i>	<i>Page</i>
VC19	2	VC26	44
VC20	4	VC27	58
VC21	28	VC28	67
VC22	32	VC29	71
VC23	36	VC30	85
VC24	38		
VC25			

Index to Subjects

Allocations: VC19
Channel Spacing: VC21, VC25
154-174 Mc Band: VC25
Channel Splitting: VC22, VC23, VC26
Field Test at 50 Mc: VC22
Operating Experience at 50 Mc: VC23
Syracuse Demonstrations: VC26
Crystal Units for Selective Networks: VC30
Current Trends: VC32
Electronics, Promise and Reality: VC24
FCC Rules and Enforcement: VC 31
Filter Design Equations: VC29
Frequency Economy: VC20
Mobile Service at 160 Mc: VC27
Transmission at 150, 450, 900, 3700 Mc: VC28



Professional Groups of the IRE

Listed below are the Professional Groups of the IRE and the corresponding assessment fees. If no amount is indicated, no assessment has yet been levied.

<i>Group</i>	<i>Assessment</i>
AERONAUTICAL AND NAVIGATIONAL ELECTRONICS.....	\$2.00
ANTENNAS AND PROPAGATION.....	4.00
AUDIO.....	2.00
BROADCAST AND TELEVISION RECEIVERS.....	2.00
BROADCAST TRANSMISSION SYSTEMS.....	2.00
CIRCUIT THEORY.....	2.00
COMMUNICATIONS SYSTEMS.....	2.00
ELECTRON DEVICES.....	2.00
ELECTRONIC COMPUTERS.....	2.00
ENGINEERING MANAGEMENT.....	1.00
INDUSTRIAL ELECTRONICS.....	2.00
INFORMATION THEORY.....	2.00
INSTRUMENTATION.....	1.00
MEDICAL ELECTRONICS.....	1.00
MICROWAVE THEORY AND TECHNIQUES.....	2.00
NUCLEAR SCIENCE.....	2.00
QUALITY CONTROL.....	2.00
RADIO TELEMETRY AND REMOTE CONTROL.....	1.00
VEHICULAR COMMUNICATIONS.....	2.00

LIQUID-LEVEL GAUGE WEARS 7 LEAGUE BOOTS

Taking inventory was an oil-industry headache until the Shand & Jurs Company of Berkeley, California developed its Electronic Precision Remote-Reading Tank Gauge System...relying on HELIPOT* precision potentiometers for translating critical measurements into voltages which are transmitted an indicator located miles away.

ank-gauging starts with a float riding on vertical guides. A perforated metal tape runs up from the float...over a sprocket-wheel...and down to a counterweight.

The sprocket-wheel, through a gear train, drives two HELIPOTS. The shaft of the first... a Model A, 10-turn unit...rotates 3600° as the float moves from the bottom of the tank to the top. The shaft of the other... a Model F, continuous-rotation unit... makes a full turn for each foot the float moves.

The voltage outputs of the two HELIPOTS are conducted to the remote station where either can be fed to the circuit of a Brown Instrument Co. self-balancing Wheatstone bridge.

The voltage of the Model A HELIPOT is read directly in feet... that of the Model F HELIPOT in 1/8" increments. Inventory of any number of tanks can be made quickly... by successively switching the outputs of their HELIPOTS into the circuit of the indicator.

Operating on a tank containing petroleum vapor, the HELIPOTS must be housed in an explosion-proof chamber. To overcome the problem of moisture condensation, the HELIPOTS operate completely immersed in oil... which enters the HELIPOTS themselves through holes in their housings. Condensation is drained periodically from the bottom of the chamber. Identical HELIPOTS, laboratory-tested while similarly immersed, showed negligible wear of coil or slider contact after 2 million revolutions.

Application Data... For complete details on this and other applications, write for Data File No. 506

*T. M. REG. U. S. PAT. OFF. 314

HELIPOT makes a complete line of single-turn and multi-turn precision potentiometers, and turns-counting DUODIALS. Many models are regularly carried in stock for immediate shipment.



 **Helipot**

first in precision potentiometers

*Helipot Corporation/South Pasadena, California
Engineering representatives in principal cities
a division of BECKMAN INSTRUMENTS, INC.*



TECHNICAL*

A new radio-operated remote control set which makes practicable the operation of a radio, radio teletypewriter, or radio telephone miles from the sending unit, has been developed by a Signal Corps non-commissioned officer, it was recently announced. The equipment is considered so promising that it has been submitted to the Signal Corps Engineering Laboratories for further tests, and, perhaps, general adoption by the Army, it was reported. The unit, about the size of a cigar box, is inexpensive to manufacture according to members of the 301st Signal Group, Seventh U. S. Army in Europe. Used in conjunction with the radio AN/GRC-26A, it reportedly can control a set two miles away by the "one-way reversible" and "duplex operational" methods as easily as one can make adjustments on radio or television set just a few feet away. The unit is capable of selecting combinations to alternately send and receive at the same time and can cut teletype tape as easily as sitting at the machine itself. In addition, radio telephone and telegraph are available by a simple flick of a switch. The remote control unit, the Signal Corps said, eliminates the use of an operator at the radio site and frees manpower that heretofore was needed to lay wire from the communications center to the site of the equipment. The device also saves the cost of wire that normally is involved in a metallic circuit from the communications center to the equipment being operated at a distance.

... The National Bureau of Standards has announced the development of an altimeter which will measure altitudes as low as two feet, attained by using appropriate frequency shifting and by modifying existing techniques for recognizing short-distance information. The instrument, called the nonquantized frequency-modulated altimeter, was designed by H. P. Kalms, J. C. Cacheris, and H. A. Dropkin as part of the Bureau's research in ordnance electronics. Since, heretofore, conventional altimeters gave information only to the closest 10 or 20 feet, the new NBS altimeter makes it possible for a helicopter pilot to know when his craft is within several feet of the landing surface, it was reported. This is accomplished through an operating frequency in the X-band of the radio spectrum (10,000 mc). ... The Office of Technical Services, Department of Commerce, in its February issue of the "Bibliography of Technical Reports," lists a number of important advances in electronics. The following government-sponsored research studies can be purchased from the Photoduplication Section, Library of Congress, Washington 25, D. C., for the reported price: "Radio Noise Consideration," PB 112552, microfilm, \$2.75, photostat, \$7.50; "Cooling De-

(Continued on page 84A)

* The data on which these NOTES are based were selected by permission from *Industry Reports*, issues of February 22, March 2 and 8, published by the Radio-Electronics-Television Manufacturers Association, whose helpfulness is gratefully acknowledged.

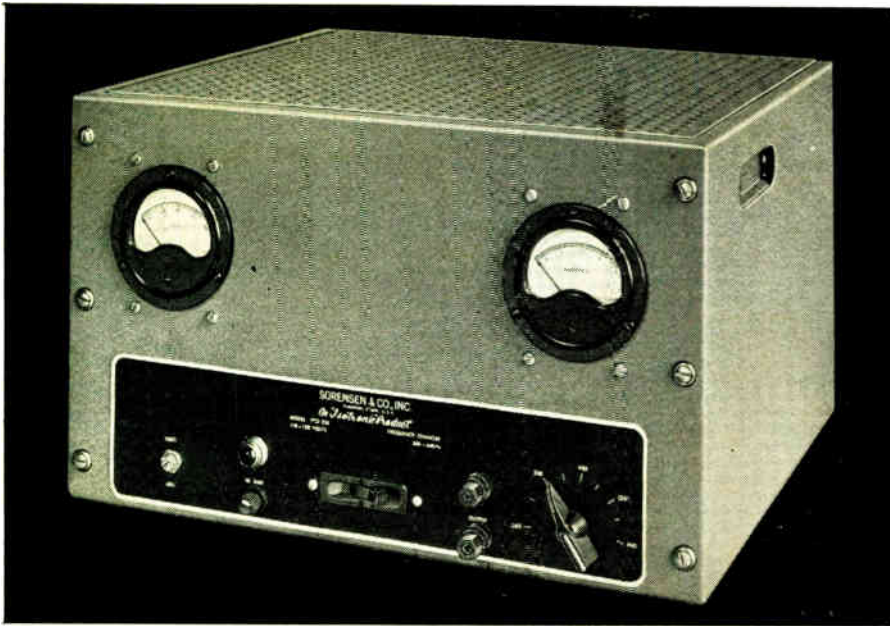

electronic frequency changers

250VA and 1000VA capacity

60~ to 60~ or 60~ to 400~

accuracy to $\pm 0.01\%$

- accurate control of frequency
- accurate control of voltage
- good wave shape
- portable
- no special wiring or installation

SPECIFICATIONS

Model	FCD250	FCD1000	FC1000
Input voltage	95-130VAC, 1 ϕ , 50-60~	208 or 230VAC, 1 ϕ , 50-60~	208 or 230VAC, 1 ϕ , 50-60~
Output voltage	115VAC, 1 ϕ , adjustable between 110-120 volts		
Output frequency	400~, adjustable $\pm 10\%$	400~, adjustable $\pm 10\%$	60~, adjustable between 45 and 65
Output voltage regulation	$\pm 1.0\%$	$\pm 1.0\%$	$\pm 1.0\%$
Output frequency regulation	$\pm 1.0\%$ in standard models; $\pm 0.01\%$ with auxiliary frequency standard (output frequency is fixed when using frequency standard)		
Capacity	250VA	1000VA	1000VA
Load range	0.1 to full load		
Distortion	5% maximum		
P. F. range	Down to 0.7 F		
Time constant	0.25 seconds		
Envelope modulation	2% maximum		

These industrial and laboratory frequency changers resulted from contracts for precision inverters. They should prove useful for testing components or complete instruments that must operate over variable frequency conditions. They can also be used as sources for precision 60~ or 400~ for timing applications, or used with servo and/or gyro motors in design work.

Sorensen electronic frequency changers are also being used with field equipment such as geophysical vans, where motor generator set frequency control is often inadequate. Another use will be for checking equipment designed for 50~ (foreign) usage; conversely, the same instrument can be used to convert 50~ line to 60~ source.

Electronic frequency changers of other ratings are now in design. We shall be happy to send further information, or to correspond with you concerning your individual requirements. Address Sorensen & Co., Inc., 375 Fairfield Avenue, Stamford, Conn. In Europe, write directly to Sorensen A.G., Gartenstrasse 26, Zurich 2, Switzerland.

SORENSEN

375 FAIRFIELD AVENUE, STAMFORD, CONN.

Giannini DIGITAL COMMUTATORS

Codes: Binary, Binary-Grey,
Binary-Decimal with
non-ambiguous outputs



(STANDARD MODEL)
\$395⁰⁰

Immediate Delivery from stock
on standard models having
following characteristics:

- 1,000 counts decimal (300° to 360°)
- 1024 counts—binary, grey (300° to 360°)
- torque—0.5 oz. in ball bearings
- inertia—400 gm. cm²
- micrometer zero adjustment
- automatic alignment—no gears

CUSTOM COMMUTATORS

Commutators can be furnished to fit specific applications by either modification of standard models or wholly new designs. Some variations now available are:

- non-linear coding
- high-count multi-turn units
- ultra low torque models
- miniature size, geared units
- direct decimal coding

G. M. GIANNINI & CO., INC.
LABORATORY APPARATUS DIVISION
PASADENA 1, CALIFORNIA

Offices: New York: Phone Judson 6-7500
Los Angeles: Phone Ryan 1-7152

Giannini

Dual-Trace Applications

WITH THE TEKTRONIX TYPE 535 OSCILLOSCOPE
AND TYPE 53C DUAL-TRACE PLUG-IN PREAMPLIFIER

Here is a combination ideally suited to most applications involving accurate comparisons of two signals.

The Type 53C Dual-Trace Unit contains two identical amplifier channels that can be electronically switched either by the oscilloscope sweep or at a free-running rate of approximately 100 kc. When amplifier switching is triggered by the sweep, the two signals to be compared appear on alternate sweeps. Because the sweeps are identical, and time-delay characteristics of the two amplifier channels are closely controlled, time comparisons accurate within 1 μsec can be made. Two simultaneous transients may be viewed by free-running the switching. Transients of as little as 1 msec duration are well delineated, having about 100 elements in each trace. For many purposes, shorter transients can be adequately observed.

The Type 535 Oscilloscope is designed to use plug-in preamplifiers. It has an exceptionally wide sweep range, high accelerating potential, new accurate sweep-delay circuitry, and many

other important features. Four Plug-In Preamplifiers have been developed for use with the Type 535, to provide an unusually high degree of flexibility in a single oscilloscope.

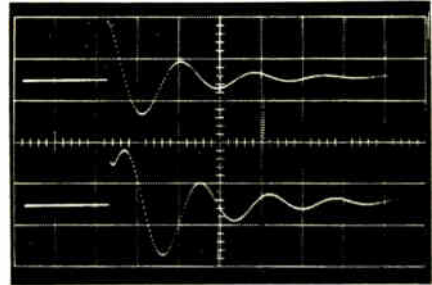

SINGLE-SWEEP PRESENTATION

Response of two networks excited by a single pulse shows free-running operation of the Dual-Trace Unit in a one-shot application. A single 200-μsec/cm sweep is used for this display.

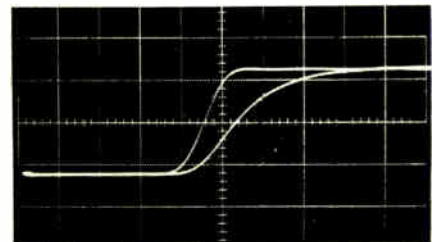

ALTERNATE-SWEEP PRESENTATION

Output of an RC network superimposed on the input pulse. Both waveforms appear on alternate 0.04 μsec/cm sweeps, accurately measuring the risetime deterioration caused by passage through the network.

MAIN OSCILLOSCOPE FEATURES

600,000,000 to 1 Sweep Range—0.02 μsec/cm to 12 sec/cm, continuously variable. Calibrated—0.02 μsec/cm to 5 sec/cm, accurate within 3%.

10 KV Accelerating Potential—Brighter display at low repetition rates.

Flexible Sweep Delay—1 μsec to 0.1 sec, jitter-free, incremental accuracy within 0.2% of full scale. Type 535 Oscilloscope—\$1300 plus price of desired plug-in units.

DUAL-TRACE PLUG-IN PREAMPLIFIER

Type 53C Specifications

Two Identical Amplifier Channels

Frequency Response—DC to 8.5 mc.

Risetime—0.04 μsec.

Sensitivity—0.05 v/cm to 20 v/cm calibrated, continuously variable to 50 v/cm.

Electronic Switching

Triggered—actuates alternate sweeps.

Free-running rate—100 kc, approximately.

Type 53C Dual-Trace Unit—\$275.

OTHER PLUG-IN PREAMPLIFIERS

Type 53A Wide-Band DC Unit—\$85.

Type 53B Wide-Band High-Gain Unit—\$125.

Type 53D High-Gain Differential Unit—\$145.

Prices f.o.b. Portland (Beaverton), Oregon.

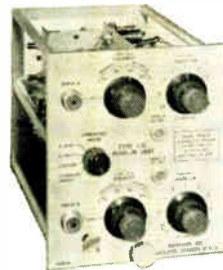
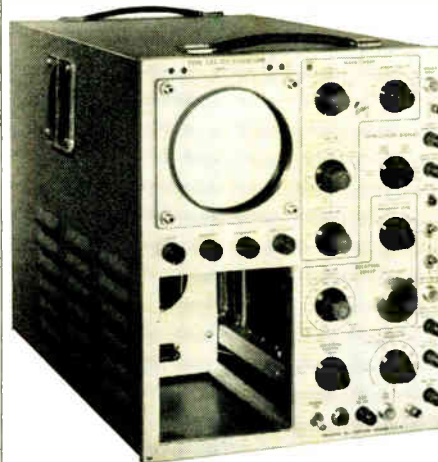

Please write for complete specifications



Tektronix, Inc.

P. O. Box 831B • Portland 7, Oregon • Cable: TEKTRONIX

Lights! Action! Camera!

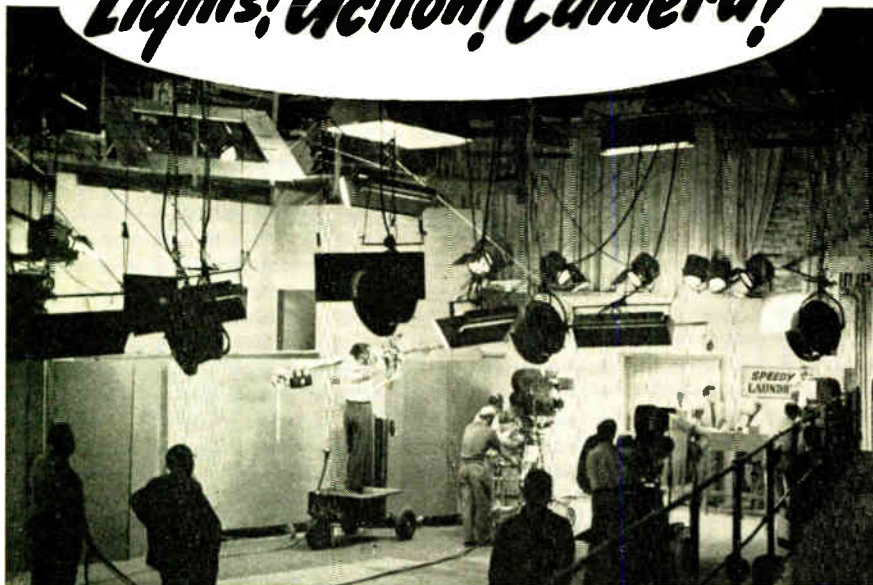

Typical Installation of B & M Spotlights in "I Love Lucy" TV Show

"Paint With Light" with

BARDWELL & McALISTER'S TV SPOTS



TV SPOT
Model 5000

This complete line of television spotlights was especially designed and engineered for television stage lighting. The many years of experience in the production of studio lights for stage and motion pictures was drawn upon to produce the B & M TV Spots which make possible painting with light. Painting with light is the ability to control the light source in order to emphasize the necessary highlights and all the important shadows. Only through controlled light can the scene and subject be given the desired brilliance, beauty, and third dimensional effects to produce ideal screen pictures..



TV SPOT
Model 1000/2000

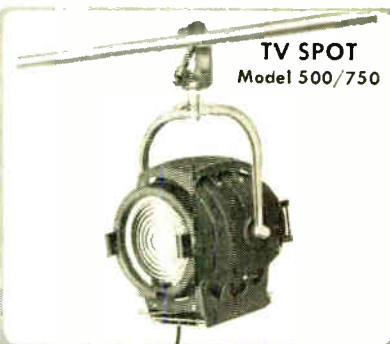

TV SPOT
Model 500/750

Our specialists are always ready to assist and advise your engineering staff so that your studios and stages will be fully equipped to properly paint with light. Write for complete specifications and prices of these B & M TV Spots..



BARDWELL & McALISTER, Inc. 2950 ONTARIO STREET
BURBANK, CALIFORNIA

Industrial Engineering Notes

(Continued from page 82A)

sign of Transceiver Unit AN/ARC-21 Radio Equipment," PB 112527, microfilm, \$2.25; photostat, \$5; "Electron Impact Study of Nitrogen in the Kinetic Energy Range 400 to 600 Volts," PB 112474, microfilm, \$3, photostat, \$8.75; "Diffraction of Microwaves by Slits and Elliptical Apertures," PB 112421, microfilm, \$2.50; photostat, \$6.25" "Free Convective Cooling in Air of Confined Small Bodies Similar to Electronic Components," PB 112402, microfilm, \$2.75, photostat, \$7.50; "Generation of Millimeter Electromagnetic Waves—Progress Report," PB 112364, microfilm, \$1.25, photostat, \$1.25. "Induction Method of Measuring Electrical Resistivity," PB 112524, microfilm, \$2, photostat, \$3.75" "Microwave Components," PB 112451, microfilm, \$2.25, photostat, \$5; "Microwave Noise Study—Quarterly Report," PB 112376, microfilm, \$2.75, photostat, \$7.50; "Scattering and Attenuation of Microwave Signals by Hydrometeors," PB 112565, microfilm, \$6.75, photostat, \$23.75; "Study of Heat Dissipation from Electronic Devices at High Altitudes," PB 112625, microfilm, \$1.25, photostat, \$1.25; "Signal Corps Electronic Computer Research and Development," PB 112629, microfilm, \$2.25, photostat, \$5. . . . **The Civil Aeronautics Administration has announced publication of "Operation of the Air Traffic Control System."** The new booklet tells how the federal airways work, describing the communications network and electronic equipment that provides navigational aid enroute and at terminals. The new booklet may be obtained from the Superintendent of Documents, Government Printing Office, Washington 25, D. C., at 25 cents per copy. . . . **The Radio Technical Commission for Aeronautics announced recently that it has developed procedures for calibrating audio- and radio-frequency signal generators to produce signals acceptable for testing and adjusting airborne VOR and ILS receivers.** The procedures

(Continued on page 86A)

Waveline Appoints Del Vento

John M. Del Vento has been appointed Chief Engineer of Waveline, Inc., Caldwell, N. J.



Prior to joining the company he served in various capacities in the field of microwave research and development.

Years of experience
proves to users . . .



the dependability of *

KOVAR

Glass-sealing Alloy

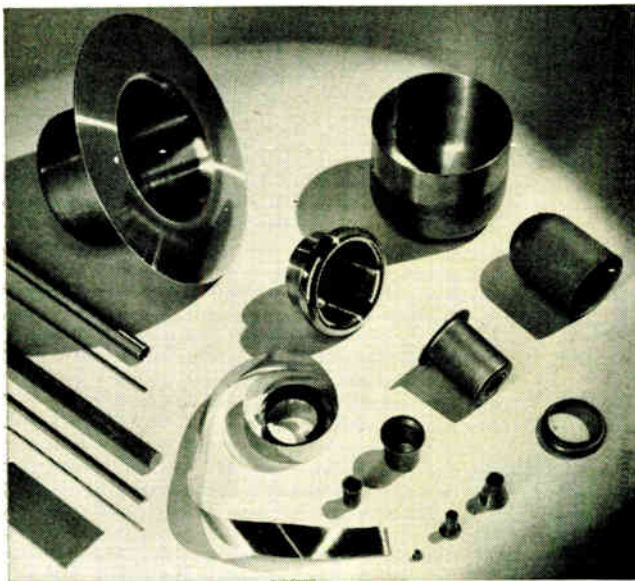









* Westinghouse Trade Mark No. 337,962

The ideal alloy for glass sealing. Kovar matches the expansivity of certain hard glasses over the entire working temperature range. It resists mercury attack, has ample mechanical strength and seals readily. A permanent and impervious bond is obtained by a closely controlled thickness of oxide on Kovar alloy interfused with hard glass.

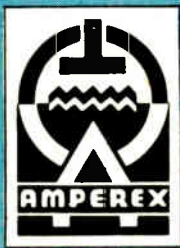
Kovar is a cobalt, nickel, iron alloy, manufactured under very carefully controlled conditions, and supplied by Stupakoff in the form of: SHEET, ROD, WIRE, FOIL, TUBING, EYE-LETS, LEADS and FABRICATED SHAPES. The prominent users of KOVAR and the length of time they have employed this metal are convincing proof of satisfaction.

Full information on the use of Kovar is given in Stupakoff Bulletin 145, which we will send upon request.

Stupakoff CERAMIC & MFG. CO.
 Latrobe, Pennsylvania

-  18 YEARS
-  18 YEARS
- Western Electric** 18 YEARS
- 16 YEARS
-  12 YEARS
-  18 YEARS
- Eimac** REG. U.S. PAT. OFF. TUBES 13 YEARS
-  11 YEARS
- MACHLETT** 15 YEARS
- Bomac** 6 YEARS
-  18 YEARS
-  5 YEARS
-  18 YEARS
-  7 YEARS
- SPERRY** 13 YEARS

Quality...



is Standard with Standard Piezo

Standard Piezo guarantees accurate and dependable quartz crystals to meet all private plane or commercial air carrier requirements.

Whether they are high or low in frequency, for use at low or high altitudes, you'll find Standard Piezo quality is consistently superior.

For your crystal requirements, standard or custom, write or call us.



Standard Piezo Co.
CARLISLE, PENNA.
Phone 1495

Announcing PRECISION D-C VOLTMETER Model 124

The Model 124 Precision D-C Voltmeter produces an accurately adjustable reference voltage for comparison with the voltage to be measured. A null indicating meter is used to indicate equality of the two voltages. Voltages between 0 and 510 Volts can be measured. A very stable regulated power supply circuit is used as the internal voltage source. It can be standardized against a built-in standard cell by a switch and control on the front panel. The switch also controls the sensitivity of the null indicator when measurements are made.

Two sensitivity ranges are provided and are selected by a switch on the front panel.

On special order, the terminals of the reference voltage may be connected to a suitable receptacle on the front panel bypassing the null indicator.

Also available for relay rack mounting.

Voltmeters for other voltage ranges supplied on special order.

Specifications:

- **VOLTAGE RANGE:** 6 to 510 Volts in steps of 10 Volts or 0 to 500 Volts in steps of 100 Volts; each step is subdivided by a vernier dial reading 10 Millivolts or 100 Millivolts, resp., per division.
- **ACCURACY:** When properly standardized, voltage indications are accurate within 0.1% in the "10 Volt" position of the range switch. Small voltage differences can be

- measured with an accuracy of better than 0.1% or 5 Millivolts, whichever is greater.
- **INPUT IMPEDANCE:** Infinite, after null balance is obtained.
- **DIMENSIONS:** 3 1/2" wide by 12" high by 8" deep, excluding carrying handle and rubber feet. Front panel: 8 1/2" wide by 11" high.



FURST ELECTRONICS

3326 W. Lawrence Ave., Chicago 25, Illinois

Industrial Engineering Notes

(Continued from page 84A)

were developed primarily to aid the operators of aircraft radio service stations. They were prepared for the more commonly-used types of signal generators, RTCA said, but also may be used to determine whether signals produced by other types are within acceptable tolerances. The calibration study was performed by RTCA Special Committee 61. Copies of the 80-page report (Paper 208-53/DO-52) may be obtained from the RTCA Secretariat, 1724 F Street, N.W., Washington 25, D. C. In addition to signal generators, standard omni-bearing selectors are used in testing VOR receivers at bearing settings other than the zero indexing position. Calibration procedures for omni-bearing selectors are being prepared for later publication, RTCA reported.

INDUSTRY STATISTICS

Over 7.2 million radios, excluding automobile sets, were shipped to dealers during 1953, according to a report issued recently from the RETMA Statistical Department. This was about two per cent above the level of shipments in 1952, but slightly below the 1951 figure. . . . During the eight-year period 1946-1953, over 28.5 million television receivers were shipped to dealers in the United States, Hawaii, and Alaska, according to a tabulation compiled recently by the RETMA Statistical Department.

FEDERAL PERSONNEL

Capt. Rawson Bennett reported for duty recently as Assistant Chief of the Bureau of Ships for Electronics. He succeeds Admiral F. R. Furth, the new Chief of Naval Research. Capt. Bennett was returned to Washington from Schenectady, N. Y., where he has been assigned as Supervising Inspector of Naval Machinery and Naval Ordnance. Prior to that he was head of the Minesweeping Branch of the Bureau for Ships. Capt. T. W. Rogers, who has served as Acting Assistant Chief of the Bureau for Electronics since Admiral Furth's transfer, will resume his duties as Assistant Director for Electronics. . . . The formal appointment of Dr. Robert D. Huntoon as Associate Director of the National Bureau of Standards for Physics has been announced by Dr. A. V. Astin, NBS Director. Dr. Huntoon also is Acting Chief of the Electronics Division, and the Central Radio Propagation Laboratory. Wide recognition has been accorded Dr. Huntoon for his research on atomic-beam measurement, special amplifiers, atomic particle counting, electronic ordnance devices, the phasing of oscillators and deuterium-deuteron nuclear reaction studies. While Director of the NBS Corona, Calif., Laboratories, he was responsible for a research and development program that included guided missiles, electronic ordnance devices, digital computers and infrared measurements.

(Continued on page 88A)

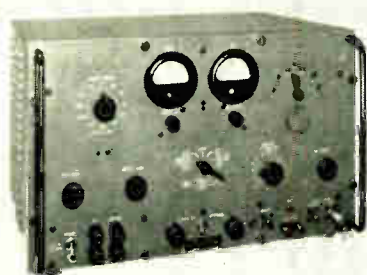

**Complete
Testing
Equipment
for**

OMNI and LOCALIZER RECEIVERS

A.R.C. Type H-14 Signal Generator



For a quick and accurate check by pilot before take-off, or for maintenance on the bench, this is the favored and dependable instrument. Checks up to 24 omni courses, omni course sensitivity, to-from and flag-alarm operation, and left-center-right on localizer. For ramp check, RF output 1 volt into 52 ohm line; for bench checks, 0-10,000 microvolts.

The H-16 Standard Course Checker is a companion instrument to the H-14.

It makes possible a precise check on the course-accuracy of the H-14 or of any other omni signal generator. Just as a frequency meter is necessary in connection with a variable frequency signal generator, the H-16 Standard Course Checker is required in connection with a VOR signal generator for a precise measurement of phase accuracy.



These instruments sold only direct from factory.

Write for detailed literature



Dependable Airborne
Electronic Equipment
Since 1928

Aircraft Radio Corp
BOONTON, NEW JERSEY

NOW

**NEW YORK —
73 RUTLEDGE ST., BROOKLYN 11, N. Y.**

CARGO PACKERS EAST & WEST COAST PACKAGING SERVICE!

**CALIFORNIA —
2050 BROADWAY, SANTA MONICA**

Individually-engineered
CLIMATE-PROOF, SHOCK-PROOF PACKAGING

Three years in making—
three days in breaking!



12-PAGE BROCHURE tells how to avoid the pitfalls, gives complete detailed information on C-P methods of protective packaging.

To meet the increased, country-wide demands of the electronics industry. Cargo Packers has now inaugurated complete facilities in the West Coast area also, for packaging protection of delicate instruments, equipment and components, including

- Special Assembly Equipment
- Experts in Military Specifications
- Economical Production line methods
- Full Compliance in Every Detail
- Competent Consulting Service

Whether in storage or in transit anywhere, absolute protection against strain, stress, shock, vibration, temperature or humidity fluctuations, moisture—or even skin damage—is assured by Cargo Packers' individual attention to every job. For recommendations on specific packaging problems, call or write our Sales-Engineering Department today.

CARGO PACKERS

INCORPORATED

New York — 73 RUTLEDGE ST., BROOKLYN 11, N. Y.
California — 2050 BROADWAY, SANTA MONICA

CLIMATE-PROOF PACKAGING

CARGO



**SPECIALISTS IN
CLIMATE-PROOF, SHOCK-PROOF
PACKAGING FOR ORDNANCE AND INDUSTRY**

KEARFOTT DEVELOPED VERTICAL GYROS

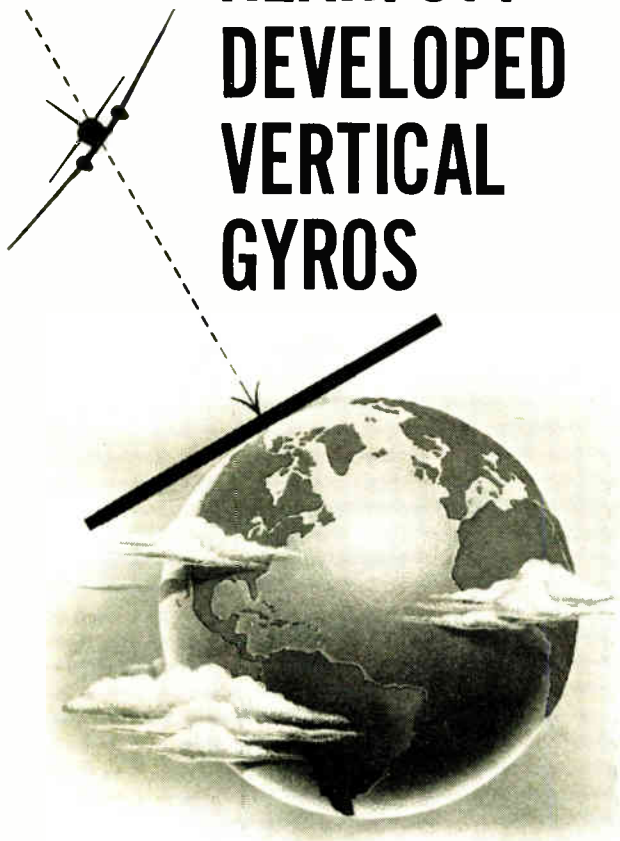

...in production

KEARFOTT vertical gyros providing continuous vertical reference within two minutes of arc under bench conditions typify the engineering knowhow and production skills available to you in the field of precision gyros for airborne control applications.

Designed for particular applications with stringent performance requirements, a wide variety of vertical gyros now in production are being used extensively in aircraft and missile control systems demanding the most precise gyro reference obtainable.

Kearfott gyros incorporate many unique features permitting operation under extreme operational or environmental conditions. A true hermetic seal in dry inert gas provides positive environmental protection. Synchro pick-offs and rigid structural elements assure performance during adverse conditions of vibration or shock.

TECHNICAL DATA SHEETS

Complete technical data in tabular form on Kearfott Precision Vertical Gyros are available on request. Send for copies for your files. Write today.

KEARFOTT COMPONENTS INCLUDE:

Gyros, Servo Motors, Synchros, Servo and Magnetic Amplifiers, Tachometer Generators, Hermetic Rotary Seals, Aircraft Navigational Systems, and other high accuracy mechanical, electrical and electronic components.

Technical Data on these and other components is available on request.



KEARFOTT COMPANY, INC., LITTLE FALLS, N. J.

Sales and Engineering Offices: 1378 Main Avenue, Clifton, N. J.

Midwest Office: 188 W. Randolph Street, Chicago, Ill. South Central Office: 6115 Denton Drive, Dallas, Texas

West Coast Office: 253 N. Vinedo Avenue, Pasadena, Calif.

A GENERAL PRECISION EQUIPMENT CORPORATION SUBSIDIARY

Industrial Engineering Notes

(Continued from page 86A)

NATIONAL TELEVISION SYSTEM COMMITTEE

Dr. W. R. G. Baker, Chairman of the National Television System Committee and Director of the RETMA Engineering Department, at the close of the RETMA Board of Directors meeting received an award from the Academy of Television Arts and Sciences for the color television work of the NTSC. The "Emmy" statuette was presented to Dr. Baker by Director H. L. Hoffman who had previously accepted the award for Dr. Baker from the ATAS in Los Angeles. NTSC was given the "distinguished contribution" award "for evolving the present-day method of attaining compatible color."

Eaton Appointed VP by National



Raymond C. Cosgrove, Chairman of the Board of the National Co., Inc., Malden and Melrose, Mass., has announced the appointment of Lynn Eaton as Vice-President in charge of sales.

New Sales Director for Servomechanisms



Servomechanisms, Inc., 500 Franklin Ave., Garden City, L. I., N. Y., has announced the appointment of C. H. Hartley to the position of Sales Director. Mr. Hartley is now located in the company's Corporate Offices in Garden City, New York.

A Revolutionary New Relay Development

of utmost importance to electrical
and electronic design engineers

The Mullenbach Capaswitch uses an entirely new and different concept in relay design to transfer the contacts; provides extreme sensitivity, low power requirements, high current-carrying capacity.

The revolutionary new Capaswitch is basically an ultra-sensitive relay with unusual current carrying capacity. It will perform all of the jobs of conventional magnetic-coil relays, within the same current carrying capacity, plus many jobs that magnetic-coil relays cannot do. However, in design it departs radically from conventional relays. Instead of the usual electromagnet armature, a unique electrostrictive capacitive element provides the mechanical energy to open and close the contacts. Only 0.5 milliwatt-seconds of operating power (150 volts d.c.) is required to close the contacts. To keep them closed requires less than 0.1 milliwatt, or less than one-hundredth the power required to keep a conventional magnetic-coil relay closed! This low power requirement opens up a vast new field of applications, eliminating need for much pre-amplified equipment.

How the Capaswitch works—Application of an actuating voltage creates a bending moment in the electrostrictive capacitive element, closing the contacts. Removal of the actuating voltage and discharge of the electrostatic element through external circuits or through a resistor, removes the bending moment, opening the contacts.

Time Delay Function—If appropriate resistances are applied in the circuit, the Capaswitch will function as a time delay relay to open or close the contacts. For longer time delays a larger condenser may be paralleled to the capacitive element.

Pulse Characteristics—Initial closing time of the Capaswitch is 10 milliseconds. However, it can be actuated by pulses as short as 10 microseconds or less. The electrostatic element may also be used to store low power pulses until sufficient voltage has been accumulated to operate the relay. However, present models cannot be used for accurate counting.

High Overvoltage Capacitance—Absence of a coil enables the Capaswitch to withstand wide voltage variations. As much as 200% overvoltage may be applied to the electrostatic element without damage. Low power requirements virtually eliminate heat and resulting dissipation problems, and reduce the number of needed components, saving space and weight.

Available now—Until recently the Capaswitch has been available only in limited quantities. Now, however, stepped-up production schedules assure increasing supplies.

OVERALL DIMENSIONS:

Length: 3½"

Width: 1-7/16"
including solder
terminals

Depth: 11/16"

Weight: 1.7 ounces

THE MODEL A-150 CAPASWITCH

a single pole, double
throw relay, rated at
1 amp., 110 v., A.C.
non-inductive load.
Normal operating
voltage 150 volts D.C.

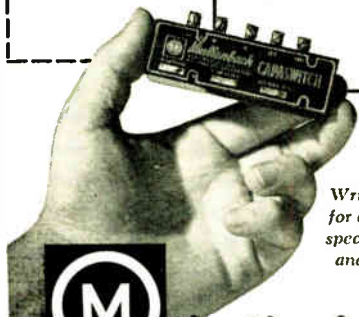

Write today
for complete
specifications
and prices!



Mullenbach
ELECTRICAL MANUFACTURING CO.
Established in 1927

2300 East 27th Street • Los Angeles 58, Calif.

New Multiple Function MICROWAVE VSWR AMPLIFIER

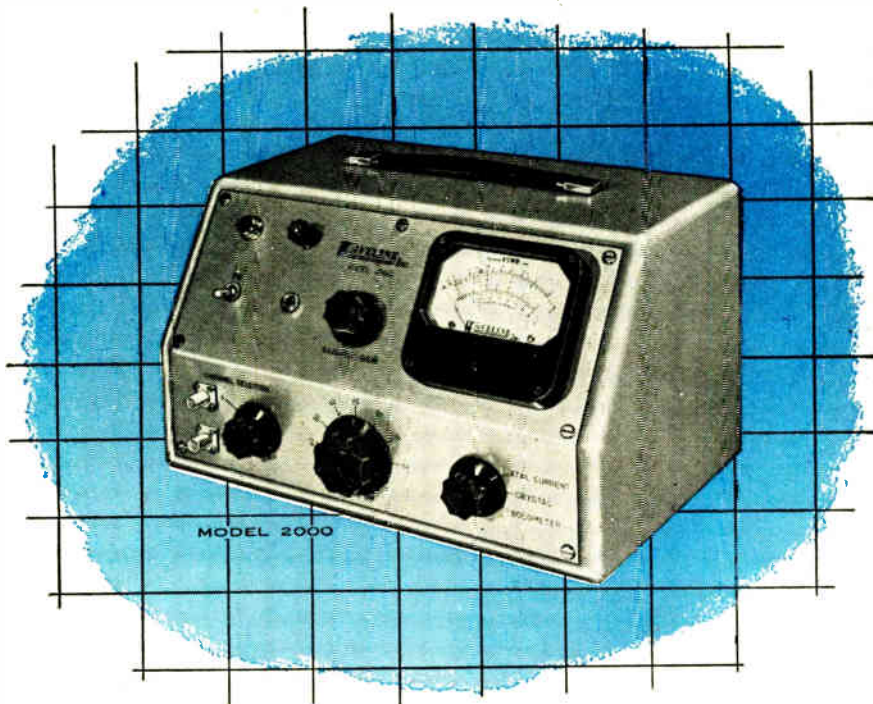

FEATURES:

- Crystal current and power monitoring
- Two channel input
- VSWR to 60 db
- Set-up signal sources

**for faster, more
accurate readings...
easier operation**

WAVELINE, precision leader in the manufacture of microwave test equipment, now offers you the ultimate in advance-design VSWR AMPLIFIERS.

This NEW Standing Wave Amplifier is the culmination of extensive research and testing... directed at developing new concepts of instrument function and design for microwave test equipment.

Exclusive combinations of features make WAVELINE microwave instruments the most valuable test equipment available today!

Technical data on microwave instruments covering the range 1,000 to 40,000 MCS available on request.

SPECIFICATIONS

New MODEL 2000 Standing Wave Amplifier

Crystal Current Measurement—a feature is incorporated making the meter available for monitoring crystal current and power.

Two Channel Input—provides in one instrument:

1. By alternate use of two channels a pulsed oscillator in combination with a calibrated attenuator provides a substitute for a costly signal generator.

2. Monitoring crystal current and measuring VSWR.

3. Both channels measure VSWR.

4. Monitoring power with bolometer and measuring VSWR.

5. Monitoring power at two points.

Sensitivity—Full scale deflection; minimum 0.3 microvolts; maximum 0.3 volts.

Selectivity—Overall Q of approx. 20.

Calibration—Calibrated for use with a square law detector. 60 db over-all range in 6 steps. Accuracy ± 0.1 db per 10 db.

Detector—Crystal rectifier or bolometer with 8.75 Ma. or 4.0 Ma. bolometer bias for standard 200 ohm bolometer, barretter or 1/100 amp instrument fuse.

Modulation Requirements—For VSWR measurement the RF source must be modulated at 1000 CPS ± 20 CPS. Plug in units for frequencies 250 to 2500 CPS available.

Price—\$200. F.O.B. Caldwell, N. J.

Sales Engineers in All Principal Cities

©NTI

WAVELINE INC.

CALDWELL, NEW JERSEY

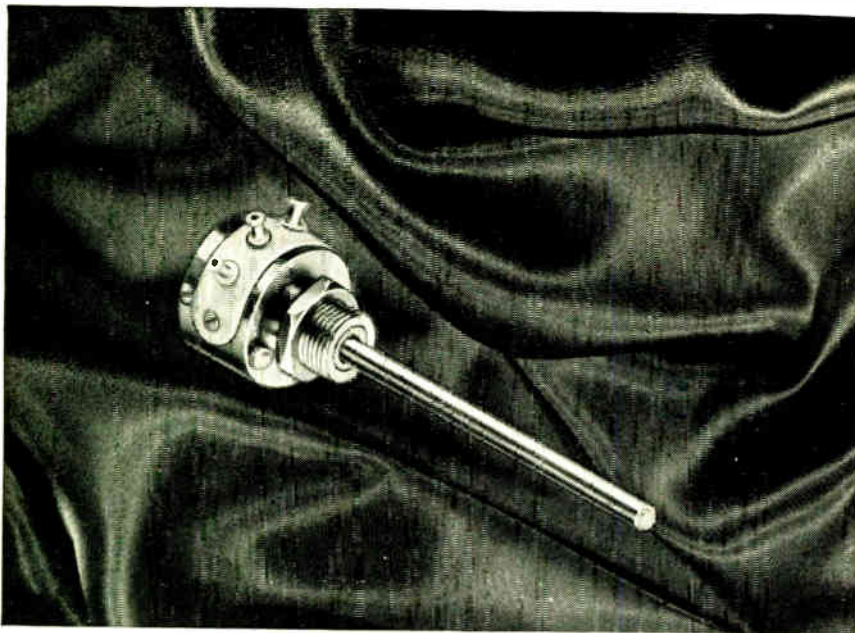

(Potentiometer is shown in actual size)

Another **NEW**

Fairchild Precision Potentiometer

The
FilmPot
TYPE
771

This metallic film potentiometer offers infinite resolution, high temperature operation (225° C.), high wattage dissipation, and 100 to 200,000 ohms resistance range in a case only 3/8" in diameter and 1/2" long. The infinite resolution of a metallic film resistance element in servo applications limits hunting and oscillating. Available with servo flange or threaded bushing mounting. Gold-plated terminals. Now manufactured to target specifications for engineering evaluation; sample orders are accepted in standard resistance values only.

Another reason why
**Fairchild can supply ALL your
precision potentiometer needs**

Fairchild makes a complete line of precision potentiometers to fill all your needs—linear and nonlinear potentiometers, singly or in ganged combinations . . . single-turn and helical . . . with servo or threaded bushing mounts . . . and with resistance elements to meet your requirements.

Fairchild guarantees accuracy of $\pm 1\%$ or better in nonlinear types and $\pm 0.5\%$ or better in linear types. Highly accurate production methods and close mechanical tolerances, plus thorough type-testing and quality control, provide high resolution, long life, low torque and low electrical noise level in every Fairchild potentiometer. For more information, or for help in meeting your potentiometer problems, call on Fairchild Camera and Instrument Corp., Potentiometer Division, 225 Park Avenue, Hicksville, L. I., N. Y., Department 140-51H.



Reports from Chapters

AERONAUTICAL AND NAVIGATIONAL ELECTRONICS

The Dayton Chapter of the Professional Group on Aeronautical and Navigational Electronics met on February 4 at the Engineers' Club of Dayton under the chairmanship of Paul Wiegert, Jr. E. G. Fubini of the Airborne Instrument Laboratory presented a paper entitled "Magnetic Airborne Detectors." Mr. Fubini reviewed briefly the problem involved in detecting and measuring very small variations in magnetic fields, such as are caused by the presence of a small ship or submarine in the earth's field. He discussed in some detail the various systems used in the past for measuring both the angle and the magnitude of the earth's field, indicating the advantages and faults of each. The system offering the greatest advantages and the one now used in detection of submarines from aircraft, utilizes small saturable reactors which generate a second harmonic component to an exciting carrier frequency when placed in a steady magnetic field. This provides by far the most sensitive system yet developed and will, under the service conditions, detect submarines at distances ranging up to 400 feet below the aircraft.

The Los Angeles Chapter of the Group met on February 2 at the IAS Building in Los Angeles, in a joint meeting with the Los Angeles Section. Dean E. Wooldridge of the Ramo-Wooldridge Corp., and Leslie Cronwell, Assistant Professor at Los Angeles State College, spoke on "Some Characteristics of Military Research and Development," and "A Look at Engineering Education in Great Britain," respectively.

ANTENNAS AND PROPAGATION

The Los Angeles Chapter on the Professional Group on Antennas and Propagation met on December 15 at the IAS Building Los Angeles, under the chairmanship of M. J. Ehrlich. Carl Linnes, Jet Propulsion Laboratories, California Institute of Technology, presented a paper entitled "Some Influences of Over-all System Performance on Antenna Systems." Bob Stevens, also of the Jet Propulsion Laboratories, spoke on "Problems in Design of Low Side Lobe Level Antennas."

AUDIO

The Albuquerque-Los Alamos Chapter of the Professional Group on Audio met on February 4 at the Radiation Therapy Building, Lovelace Clinic, Albuquerque, under the chairmanship of A. M. Garblik. F. G. Hirsch, Medical Director of Sandia Corp., spoke on "Some Physiological and Psychological Considerations in High Fidelity Audio Reception."

(Continued on page 94A)

IDEAL FOR TRANSISTOR CIRCUITS

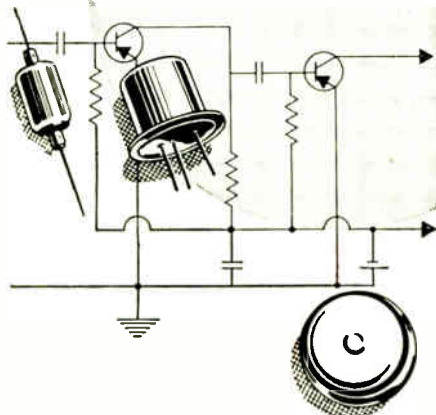

MALLORY

**MERCURY BATTERIES and
SILVERLYTIC CAPACITORS**

Designed Specifically for
TRANSISTOR APPLICATIONS
Available Now in
PRODUCTION QUANTITIES



Mallory Mercury Batteries are ideally suited for the power supply requirements of transistor circuits.

Available as single cells or multi-cell packs in a wide range of voltages, they deliver the constant energy output needed for best results.



Also perfectly suited to transistor applications, these tiny, Mallory-developed Silverlytic Capacitors have been expressly designed for the requirements of low voltage circuits and miniaturization.

For complete data, write to
P. R. Mallory & Co. Inc.
Indianapolis 6, Indiana

P. R. MALLORY & CO. INC.
MALLORY

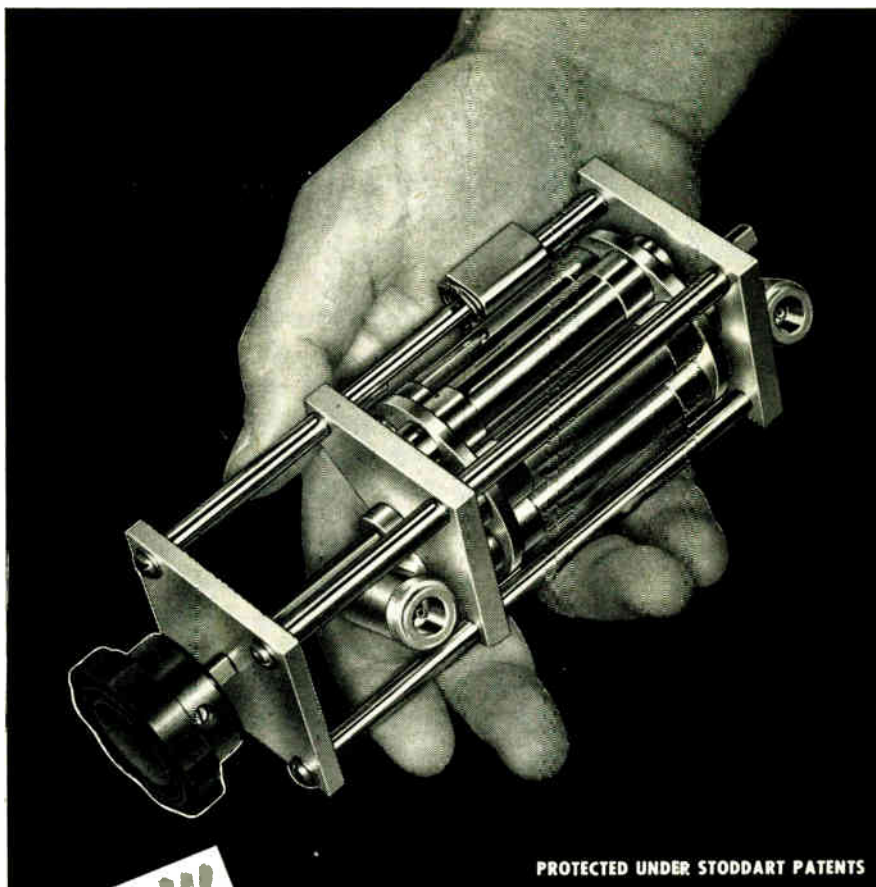

PROTECTED UNDER STODDART PATENTS

NOW

Precision Attenuation to 3000 mc!

TURRET ATTENUATOR featuring "PULL-TURN-PUSH" action

**SINGLE "IN-THE-LINE"
ATTENUATOR PADS
and
50 ohm COAXIAL
TERMINATION**



FREQUENCY RANGE:

dc to 3000 mc.

CHARACTERISTIC IMPEDANCE:

50 ohms

CONNECTORS:

Type "N" Coaxial female fittings each end

AVAILABLE ATTENUATION:

Any value from .1 db to 60 db

VSWR:

<1.2, dc to 3000 mc., for all values from 10 to 60 db

<1.5, dc to 3000 mc., for values from .1 to 9 db

ACCURACY:

±0.5 db

POWER RATING:

One watt sine wave power dissipation

*Send for free bulletin entitled
"Measurement of RF Attenuation"*

*Inquiries invited concerning pads or
turrets with different connector styles*

STODDART AIRCRAFT RADIO Co., Inc.
6644-C Santa Monica Blvd., Hollywood 38, California • Hollywood 4-9294



DESIGNER'S

Micro-miniature Tantalitic capacitors give new design flexibility

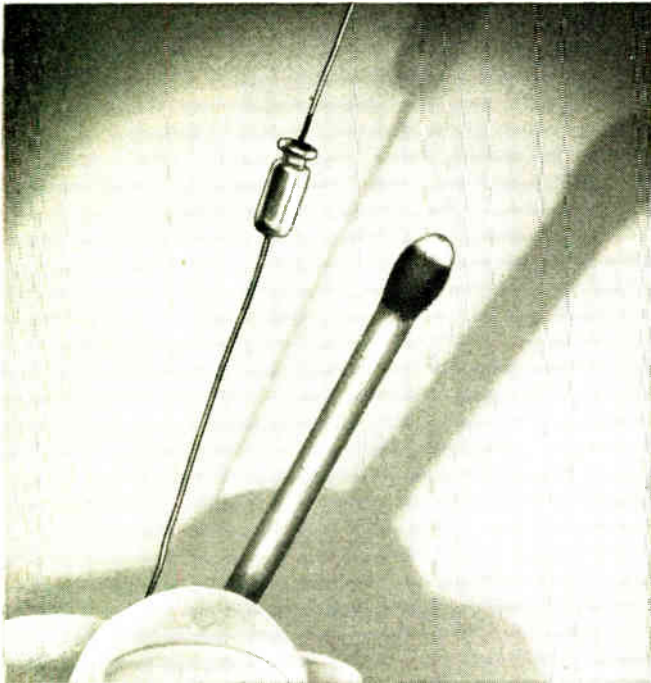

Smallest electrolytic capacitors commercially available

Micro-miniature Tantalitic capacitors can now be supplied in ratings up to 20 volts, or, up to 8 microfarads in the $\frac{5}{16}$ " long case—higher capacitance in a $\frac{1}{2}$ " case size . . . with -0% to $+100\%$ capacitance tolerance. They give you new design flexibility in low-voltage, d-c circuits—particularly transistorized subminiature assemblies where space is at a premium.

Designed especially for nonresonant, noncritical applications such as coupling, by-pass and filtering, G-E micro-miniature Tantalitic capacitors outperform aluminum electrolytics in electrical stability, operating and shelf life because of the inert characteristics of tantalum metal. They operate over a $-20C$ to $+50C$ range and may be stored at $-65C$. With some capacitance derating, Tantalitic capacitors perform well below $-20C$ —with some life limitations they will also perform satisfactorily above $+50C$.

You may obtain samples 2 to 3 weeks after your order is received at the factory. Production lots are supplied 6 to 8 weeks after the order is received. For more information see your G-E Apparatus Sales representative, or write for Bulletin GEA-6065.

G.E. builds dependability into electronic transformers—3 ways

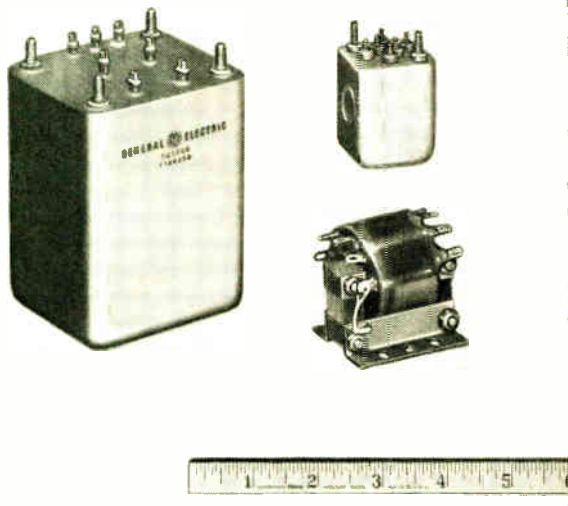

From laboratory samples to the last production model, dependability is built into G-E electronic transformers. Here's how:

- 1. INTEGRATED FACILITIES:** G-E labs, testing facilities, and materials sources are co-ordinated to help get you the transformers you want—when you want them.
- 2. MECHANIZATION:** The G-E plant is mechanized and staffed to handle large-quantity production, while maintaining laboratory sample quality.
- 3. EXPERIENCE:** G-E personnel have worked hand-in-hand with electronics manufacturers for years and consequently keep *your* problems in mind as they produce transformers for your particular, specialized applications. See your G-E Apparatus Sales representative for more information.

GENERAL ELECTRIC

DIGEST

TIMELY HIGHLIGHTS ON G-E COMPONENTS



New electronic relays have high sensitivity

This new electronic resistance-sensitive relay is able to amplify minute currents carried by very delicate contacts. Even a wet thread will provide enough signal for it to operate.

Sensitivity level is set by adjusting dial, which can be locked in place. The relay may be remotely controlled from as far away as 500 feet. Each can be set for either "normal" (relay "drops-out") or "reverse" (relay "picks-up") operation of the magnetic relay included in the device.

Built for long life, its enclosure is weather-resistant and dust-tight. Terminals are easily accessible; all components of this G-E relay are open for ease in servicing. For further information send for Bulletin GEA-5893.

Fast, accurate circuit analysis

This self-contained, highly stable G-E self-balancing potentiometer rapidly converts small d-c voltages to measurable currents—without loading the measured circuit—for analysis of electronic circuits. It is consistently accurate because simple controls, and automatic, rapid circuit balance minimize operator errors. Easily changed resistor permits selection of input ranges from 100 microvolts to one volt d-c full scale with 5-milliampere d-c output. See Bulletin GEC-367.



Tiny signals amplified

Combining amplifying and rectifying elements in a unit, G-E amplistats (self-saturating magnetic amplifiers) "sense" small signal changes, amplify them greatly, and impart the amplified signal to a system to obtain the desired control. They give you the practical advantages of virtually instantaneous response, low power consumption, long life, and electrical signal isolation. Obtain assistance in applying G-E amplistats at your G-E Apparatus Sales Office. See Bulletin GEA-5950.

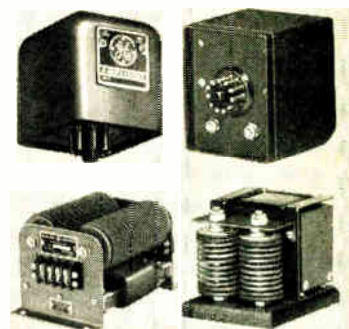

Small rectifier has high output

G-E germanium rectifiers offer the highest output in the smallest of rectifiers. For example, the dime-sized, sealed, air-cooled type is available in ratings up to 50 volts, 0.4 amperes d-c. Germanium rectifiers have these advantages: *high efficiency*—operate 98% to 99% efficient; *compactness*—small size and weight per watt output means you can build more compact assemblies; and *long life*—two-year life tests show no detectable aging. Write for Bulletin GEA-5773.

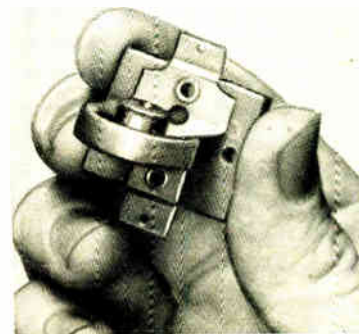

EQUIPMENT FOR ELECTRONIC MANUFACTURERS

Components	Fractional-hp motors	Development and Production Equipment
Meters, instruments	Rectifiers	Soldering irons
Dynamotors	Timers	Resistance-welding control
Capacitors	Indicating lights	Current-limited high-potential tester
Transformers	Control switches	Insulation testers
Pulse-forming networks	Generators	Vacuum-tube voltmeter
Delay lines	Selkyns	Photoelectric recorders
Reactors	Relays	Demagnetizers
Motor-generator sets	Amolidynes	
Inductrols	Amplistats	
Resistors	Terminal boards	
Voltage stabilizers	Push buttons	
	Photovoltaic cells	
	Glass bushings	

General Electric Company, Apparatus Sales Division
Section B667-28, Schenectady 5, New York

Please send me the following bulletins:
 for reference only X for planning an immediate project

- GEA-5773 Germanium Rectifiers
- GEA-5893 Electronic Resistance Sensitive Relay
- GEA-5950 Amplistats
- GEA-6065 Micro-miniature Tantalum Capacitors
- GEC-367 Self-balancing Potentiometer

Name

Company

City..... State

IF IT'S NEW . . . IF IT'S NEWS . . . IT'S FROM **ELCO**

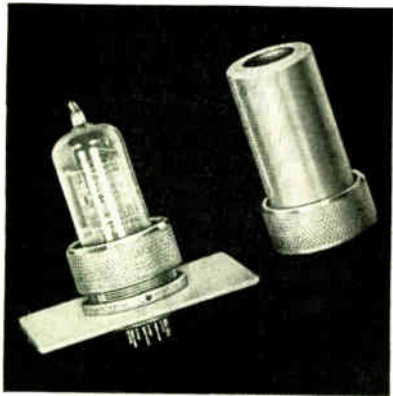

News that is bound to make headlines again for Elco Corporation is its new hermetically-sealed socket for use at high altitudes; and to give complete protection against moisture conditions. Floating contacts of heat-treated beryllium-copper assure complete relief of strain from glass of tubes. The Kel-F body is retained in an aluminum or brass

housing, terminating with hermetic-seal on chassis end. A retainer ring lined inside with silicon rubber screws on to the housing, forming a complete seal around the tube; and also acts as tube retainer. Water absorption: 0. Condensation inside socket: practically 0. Contact resistance .001 Ω . Silicon seal withstands temperature up to 525° F. Complete contact float; excellent tube retention under pressure. Available in 7- and 9-pin miniature tube class, with or without shields. Drawings and prices are yours upon request.

For Catalog Sheets, Call GARfield 6-6620 or Write ELCO Corp., 190 W. Glenwood, Phila. 40, Pa.



(Continued from page 90A)

The Chicago Chapter of the Group met on February 19 at the Western Society of Engineers Building in Chicago. P. Williams and J. T. Williams were co-chairmen. J. T. Clark, El-Rad Manufacturing Co., presented a paper entitled "Engineer's Approach to Hi-Fi." It was a joint meeting with the Broadcast and Television Receivers' Chapter.

The Houston Chapter on the Group met on February 11 at the Southern States Life Insurance Co. Auditorium in Houston, under the chairmanship of L. A. Geddes. Rod Parvin and Don Freeman, sales engineers of Reeves Soundcraft Ltd., discussed the manufacturing techniques and general properties of the new Mylar magnetic recording tape. Following the discussion, demonstrations were given which illustrated the tensile strength temperature stability and fineness of finish now possible with this new recording medium. Commercial shapes and sizes were also exhibited and samples of the tape were given to the audience. This was a joint meeting with the Professional Group on Instrumentation.

The Philadelphia Chapter met on February 18 at WCAU Studios in Philadelphia. Dr. Daniel W. Martin, Acoustical Consultant for the Baldwin Co., spoke on "Musical Tone Radiation."

CIRCUIT THEORY

The Albuquerque-Los Alamos Chapter of the Professional Group on **Circuit Theory** met on January 27 at the University of New Mexico. Leo V. Skinner, Captain in the U.S.A.F. spoke on "Kirchoff vs. Lagrange" and "Stability Criteria." Col. Skinner presented the first part of his paper on "Kirchoff vs. Lagrange" at the December 9th meeting of the Group.

The Los Angeles Chapter of the Group met on January 14 at the Institute for Numerical Analysis in Los Angeles under the chairmanship of John Aseltine. Louis Weinberg, Research Physicist at Hughes Aircraft Co., spoke on "Transistors and Their Applications."

COMMUNICATIONS SYSTEMS

The Washington, D. C. Chapter of the Professional Group on **Communications Systems** met on January 25 at the National Academy of Sciences Building in Washington, under the chairmanship of C. L. Engleman. Sidney T. Fisher, President of the Northwest Telephone Co., and Charles B. Fisher, President of Radio Engineering Products Ltd., spoke together on "Arctic VHF Radio Relay System Problems." The paper was discussed by Messrs. Jones, Toth, Wallace, Ould, Hessel and others. A number of color lantern slides were shown after the talk which not only illustrated the rather arduous conditions encountered in the Arctic, but also were found very entertaining.

(Continued on page 96A)

IT'S HARVEY FOR PROMPT "OFF-THE-SHELF" DELIVERY

Whether it's equipment, components or other electronic requirements, you will always find them in Harvey's extensive stocks, ready for immediate delivery to you anywhere.

WRITE
PHONE
or WIRE

Harvey's twenty-five years of service to the industry are your assurance of understanding 'know-how' and complete dependability.



Telephone
JUdson 2-1500

HARVEY

RADIO COMPANY, INC.
103 West 43rd St., New York 36, N. Y.



(Continued from page 94A)

COMPONENT PARTS

The Philadelphia Chapter of the Professional Group on Component Parts met on February 15 at Towne Scientific School in Philadelphia, under the chairmanship of D. C. Bowen. Dr. W. T. Sackett of the Battelle Memorial Institute spoke on "Problems and Procedures in Obtaining Short-Term Life Ratings for Composition Resistors." Dr. Sackett pointed out that some military applications of electronic components require operation at higher than normal ambient temperature and loads. If this is done, the penalty of shorter lives must be paid. Before such applications can be made on a sound basis, procedures for obtaining short-term life ratings as a function of temperature, load, and altitude must be obtained. A previous paper given at the Eighth National Electronic Conference described a proposed step method of evaluating components. Dr. Sackett's talk presented an experimental evaluation of the proposed method, together with a discussion of problems of life definition, variability, conditioning, and sampling. The paper was discussed by all present.

ELECTRON DEVICES

The San Francisco Chapter of the Professional Group on Electron Devices met on February 17 at Stanford University. Stanley F. Kaisal was acting chairman. Walter Haaek of Western Gold and Platinum Co. of San Francisco spoke on "Brazing for Vacuum Tubes." The paper was discussed by H. A. Folgner, Manager of the Los Angeles Plant of Handy & Harman, Oakland, Calif.

ELECTRONIC COMPUTERS

The Washington, D. C. Chapter of the Professional Group on Electronic Computers met on January 6, at the PEPCO Auditorium in Washington under the chairmanship of C. V. L. Smith, Dr. C. E. Miller, of the ERA Division of Remington-Rand presented a paper entitled "The ERA 1103 Computer." This Chapter also met on February 3 to hear a paper presented by Joe Siller of the Diamond Ordnance Fuze Laboratory.

The Albuquerque Chapter of the Group met on January 26 for the election of officers. The following officers were elected: Chairman, J. P. Shoup, Vice-Chairman, Karl Ball, and Secretary-Treasurer, Julian E. Gross. Ralph McGehee was appointed Meetings and Papers representative. This Chapter also met on February 17 at Mitchell Hall at the University of New Mexico under the chairmanship of J. P. Shoup. Frank O. Lane presented a paper entitled "The Analog Computer as an Automatic Computing Machine."

The New York and Long Island Chapter of the Group met on December 1 at

(Continued on page 96A)

**A NEW
SUB-MINIATURE
PRECISION
QUARTZ CRYSTAL
THAT
USES
ONLY 1/5th
THE
SPACE
FORMERLY
REQUIRED**

The McCoy M-20 "McMite" has a frequency range of 5.0 mc. to 110 mc. It's a sub-miniature hermetically sealed unit, adaptable to multi-channel design for communications and frequency control equipment. Can be plugged into a sub-miniature tube socket, wired into miniature selector switch assembly or can be soldered to a printed circuit terminal board. Meets Military Specification requirements for fundamental operation above 5 mc. and overtone operation above 15 mc. The "McMite" does not sacrifice stability or dependability but meets same characteristics and performance requirements as larger crystal units used by the Military.

Send for **FREE** catalog today on the McCoy line of high quality, precision made quartz crystals.

McCoy ELECTRONICS CO.
MT. HOLLY SPRINGS PENNSYLVANIA



McCoy M-20 "McMite"

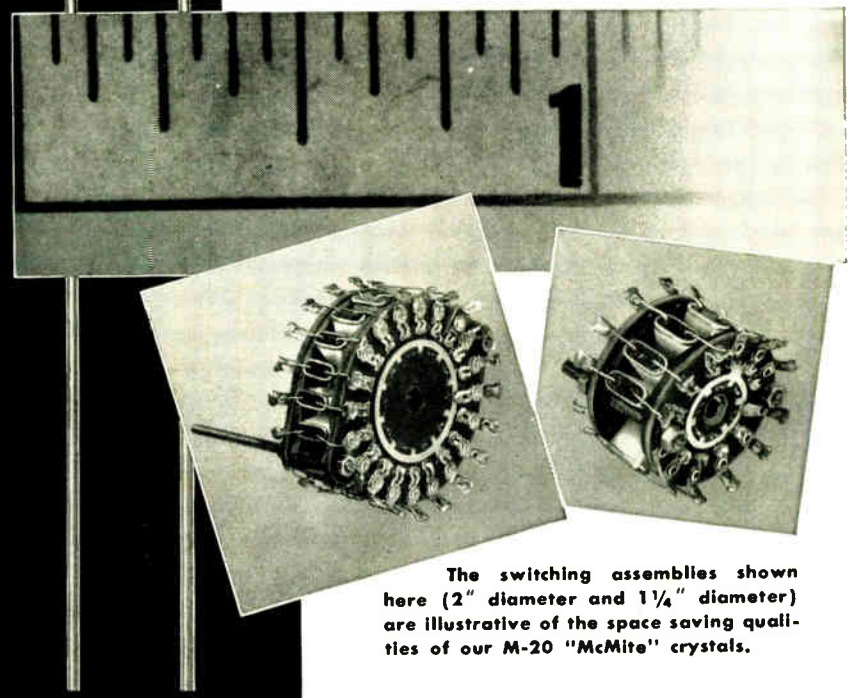
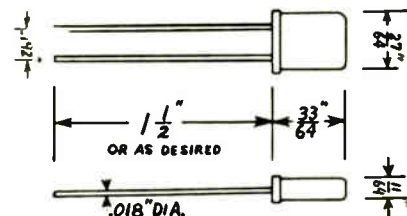

The switching assemblies shown here (2" diameter and 1 1/4" diameter) are illustrative of the space saving qualities of our M-20 "McMite" crystals.

Lapp

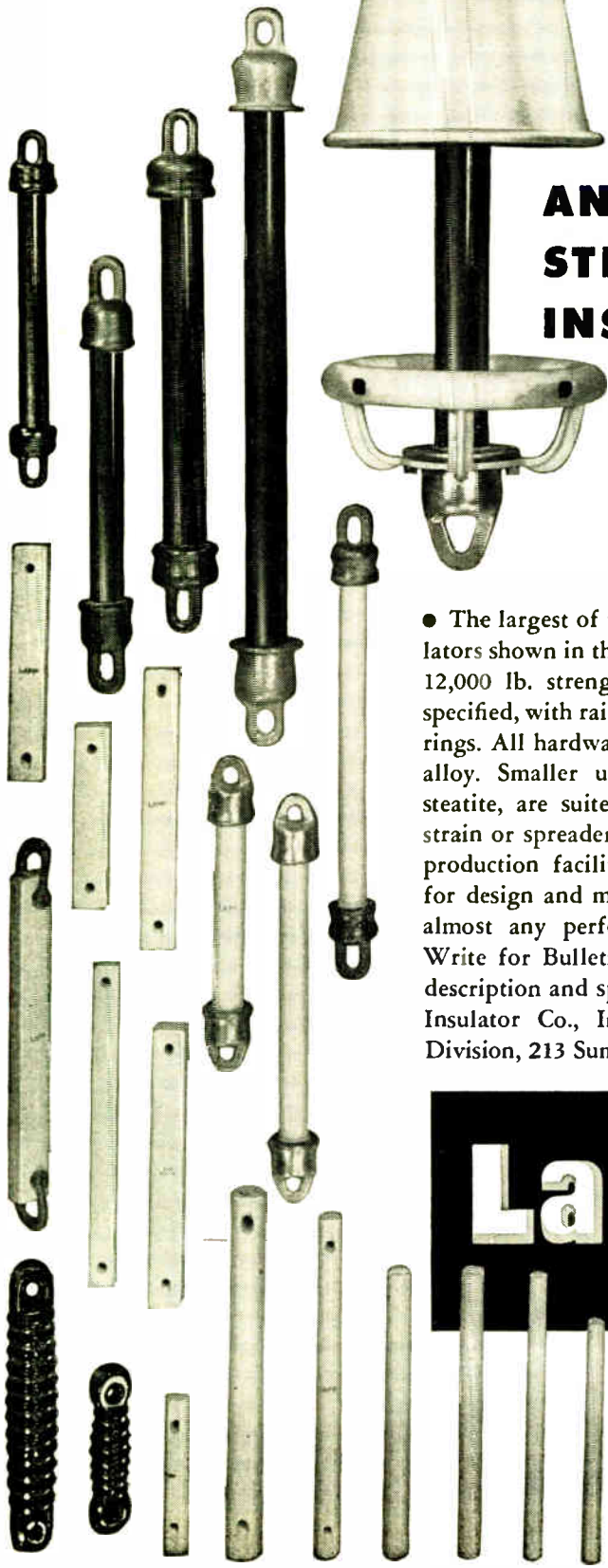

ANTENNA STRAIN INSULATORS

● The largest of the porcelain rod insulators shown in the illustration develops 12,000 lb. strength. It is available, if specified, with rain shield and/or corona rings. All hardware is silicon aluminum alloy. Smaller units, in porcelain or steatite, are suited to lighter duty for strain or spreader use. Engineering and production facilities are also available for design and manufacture of units to almost any performance specification. Write for Bulletin 301, with complete description and specification data. Lapp Insulator Co., Inc., Radio Specialties Division, 213 Sumner St., Le Roy, N. Y.

Lapp



(Continued from page 95A)

IBM World Headquarters in New York. John Bartelt, Engineer for IBM, spoke on the IBM 701 Computer. Election of officers and adoption of By-Laws was held at this meeting. This Chapter also met on January 26 at La Guardia Airport under the chairmanship of Daniel Haagens to hear Craig Andrews, E. L. Schmidt, and Charles Ammond of the Teleregister Corp. and American Air Lines speak on "The American Airlines Reservisor."

INFORMATION THEORY

The Albuquerque-Los Alamos Chapter of the Professional Group on **Information Theory** met on January 13 at Mitchell Hall, University of New Mexico to hear Alex Fursa of the Sandia Corp. speak on "Maxwell's Demon Cannot Work." Mr. Fursa also spoke at the February 10th meeting of the Chapter. His paper was entitled "Application of Information Theory and Negentropy to Physical Measurements."

The Washington, D. C. Chapter of the Group met on February 15 at the Engineers Club of Washington. The interim chairman was Charles R. Tieman. Dr. W. G. Tuller, Vice President of Engineering at Melpar Corp. presented a paper entitled "Information Theory Today." Permanent officers of the Chapter were elected to serve until June 1955: Chairman, Robert M. Page, Vice-Chairman, Ben C. Melton, and Secretary, Charles R. Tieman.

RADIO TELEMETRY AND REMOTE CONTROL

The Los Angeles Chapter of the Professional Group on **Radio Telemetry and Remote Control** met on February 16 at the IAS Building in Los Angeles, under the chairmanship of J. R. Kauke. F. M. Riddle of the Jet Propulsion Laboratory, California Institute of Technology, spoke on "Transistors in Telemetry." Ed Perce, Chief Engineer of the Ralph M. Parsons Co., spoke on "Improved Decommuation Equipment."

VEHICULAR COMMUNICATIONS

The Chicago Chapter of the Professional Group on **Vehicular Communications** met on February 19 at the Western Society of Engineers Building in Chicago, under the chairmanship of William J. Weisz. Edwin L. White, Chief of the Safety & Special Services Bureau of the Federal Communications Commission presented a paper entitled "Can Mobile Radio Grow?" The paper was followed by a general discussion of the question.

NEW!



for convenient point-to-point wiring...



MINIATURIZED 5 AND 10 WATT WIRE-WOUND RESISTORS!

Blue AXIAL LEAD Jackets[®]

PHOTOGRAPHS ACTUAL SIZE

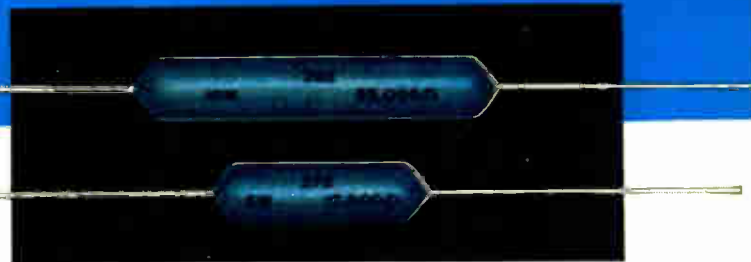

Here are two *truly miniaturized* self-mounting wire-wound power resistors to simplify your TV and industrial electronic production where space is a factor. They're ideal for point-to-point wiring, terminal board mounting, and processed wiring boards, where they fit in admirably in dip-soldered subassemblies.

Axial lead Blue Jackets are rugged vitreous enamel power resistors built to withstand the severest humidity performance requirements. As for *economy*, these newest members of the Sprague Blue Jacket family are low in cost... eliminate need for extra hardware... save time and labor in mounting!

You can get these outstanding new Blue Jacket Resistors without delay in any quantity you require. Sprague Engineering Bulletin 111 gives full data on these and all other commercial Blue Jacket Resistors. Send for your copy.

SPRAGUE ELECTRIC COMPANY
235 Marshall Street, North Adams, Mass.

SPRAGUE TYPE NO.	WATTAGE RATING	DIMENSIONS L (inches) D		MAXIMUM RESISTANCE
27E	5	1 1/8	5/16	17,500 Ω
28E	10	1 7/8	5/16	35,000 Ω

Standard Resistance Tolerance: ±5%

SPRAGUE

PIONEERS IN ELECTRIC AND ELECTRONIC DEVELOPMENT

NORTH ADAMS, MASSACHUSETTS

EXPORT FOR THE AMERICAS: SPRAGUE ELECTRIC INTERNATIONAL LTD., NORTH ADAMS, MASS. CABLE: SPREXINT

CO-AX

4 mmf/ft



★ ULTRA LOW capacitance & attenuation

WE ARE SPECIALLY ORGANIZED TO HANDLE DIRECT ORDERS OR ENQUIRIES FROM OVERSEAS
SPOT DELIVERIES FOR U.S.
 BILLED IN DOLLARS—
 SETTLEMENT BY YOUR CHECK
CABLE OR AIRMAIL TODAY

TYPE	μm F/ft	IMPED.Ω	O.D.
C1	7.3	150	.36
C11	6.3	173	.36
C2	6.3	171	.44
C22	5.5	184	.44
C3	5.4	197	.64
C33	4.8	220	.64
C4	4.6	229	1.03
C44	4.1	252	1.03



NEW 'MX and SM' SUBMINIATURE CONNECTORS
 Constant 50Ω-63Ω-70Ω impedances

TRANSRADIO LTD. 138A Cromwell Rd. London SW7 ENGLAND CABLES: TRANSRAD, LONDON



AKRON

"Evolution of the Universe," by Dr. R. A. Alpher, Johns Hopkins University; March 16, 1954.

ATLANTA

Discussion and demonstration of precautionary measures taken to prevent failure of service at a broadcast station, by Ivan Miles, WGST; election of officers; February 19, 1954.

Films: "The Guiding Hand" and "For Progress—Call Dixie"; March 19, 1954.

BEAUMONT-PORT ARTHUR

Field inspection of KPRC-TV; February 24, 1954.

"Capacitors," by W. M. Allison, Sprague Electric Company; February 25, 1954.

BINGHAMTON

"Color Television," by Lou Stantz, W.N.B.F.-AM-TV; February 17, 1954.

"Cathode Ray and TV Phosphors," by A. B. Davis, Sylvania Electric Products Inc.; March 8, 1954.

BUFFALO-NIAGARA

"Color Television—Its Challenge to the Engineer,"—written by Donald G. Fink. Speaker: Karl Wendt, Wendt-Squires, Inc.; February 17, 1954.

"Methods of Cooling Electronic Equipment," by J. P. Welsh, Cornell Aeronautical Labs. Inc.; March 17, 1954.

CEDAR RAPIDS

"Some Applications of the High Speed Differential Analyzer," by V. C. Rideout, Faculty, University of Wisconsin; February 17, 1954.

CHICAGO

"Operation of a Computing Center," by David Rubinfien, Computing Center; February 19, 1954.

"Color Television Receivers," by W. O. Swinyard, Hazeltine Research Inc.; March 4, 1954.

CLEVELAND

Symposium on Cleveland Industry—Dr. Begun, Chairman.

COLUMBUS

Panel on "Professional Ethics and Attitudes"; Dr. R. C. McMaster, Battelle Memorial Institute; W. P. Corcoran, Ohio Bell Telephone Company; Paul Mazuzan, National Electric Coil Company; February 9, 1954.

"Ferrites in Microwave Applications," by J. H. Rowen, Bell Telephone Labs.; March 9, 1954.

DALLAS-FORT WORTH

"Development and Industrial Applications of the Transistor," by Harold Danchik; "Block Diagrams for TV Receivers," by E. M. Martin, Jr.; and "Investigation of Premature Firing of Blasting Caps," by Kenneth Zerbe; all students, Southern Methodist University; March 19, 1954.

DAYTON

"Color Television," by C. N. Hoyler, David Sarnoff Research Center, RCA; March 17, 1954.

DES MOINES-AMES

"Getting Acquainted with Single-Sideband," by Warren Bruene, Collins Radio Co.; March 3, 1954.

"Computer Applications of Square Loop Magnetics," by Dr. S. M. Rubens, Engineering Research Associates; March 9, 1954.

(Continued on page 100A)

the COMPLETELY NEW

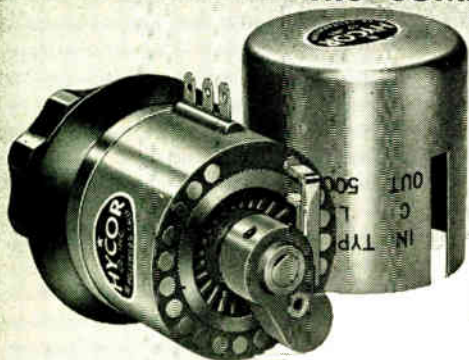

HYCOR

VARIABLE ATTENUATOR

... a revolutionary design in attenuators!

- PROOF against SHOCK — MOISTURE — TEMPERATURE
- Withstands ambient temperatures of -40°C. to $+100^{\circ}\text{C.}$; 95% humidity.
- Resistive elements are accurate, noninductive, wire-wound and hermetically sealed in a special tough plastic compound.
- Greater power dissipation.
- Switch surface flat and smooth . . . easy to clean, BRUSHES CANNOT TRIP, exceptionally long life.
- QUIET . . . extremely low switch noise level . . . ideal audio mixer controls.
- "Lubricated for life" bearings.
- Stack types available with "LADDER," "T," "H," "L" and potentiometer configurations up to 32 steps.

Send for Bulletin A-2 for specifications and prices.

Representatives:

BEEBE ASSOCIATES
 1155 Waukegan Road, Glenview, Illinois
 BURLINGAME ASSOCIATES
 103 Lafayette Street, New York City
 HARRISON J. BLIND
 1616 Cord Street, Indianapolis 24, Indiana

HYCOR SALES COMPANY

of California

11423 VANOWEN STREET
 NORTH HOLLYWOOD, CALIF.

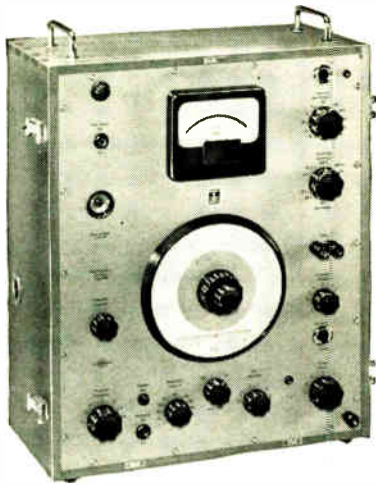

VERSATILE SIGNAL SOURCE speeds electro-acoustical measurements
Bruel & Kjaer Beat Frequency Oscillator, Model BL-1012

This Beat Frequency Oscillator is designed to incorporate the many features required in a complete and flexible signal source such as — continuously tuned frequency range, metered output, frequency modulating circuit, variable compression and noiseless oscillator stop switch.

When coupled with the Bruel & Kjaer Level Recorder, the Oscillator automatically sweeps through the audio frequency range. This permits fast, accurate recording of frequency response, sound insulation properties, reverberation times, energy decay, etc. The Oscillator has a high frequency accuracy; $1\% \pm$ one cycle per second. An incremental tuning adjustment and scale permit very accurate frequency setting. An automatic gain control circuit is utilized to maintain the desired output voltage for constant current, voltage, or sound pressure.

For complete specifications on this and other Bruel & Kjaer instruments, write Brush Electronics Company, Dept. F-5A, 3405 Perkins Avenue, Cleveland 14, Ohio.

ACOUSTIC AND TEST INSTRUMENTS

Bruel & Kjaer instruments, world famous for their precision and workmanship, are distributed exclusively in the United States and Canada by Brush Electronics Company.

- BL-1012 Beat Frequency Oscillator
- BL-1502 Deviation Test Bridge
- BL-1604 Integration Network for Vibration Pickup, BL-4304
- BL-4304 Vibration Pickup
- BL-2002 Heterodyne Voltmeter
- BL-2105 Frequency Analyzer
- BL-2109 Audio Frequency Spectrometer
- BL-2304 Level Recorder
- BL-2423 Megohmmeter and D. C. Voltmeter
- BL-3423 Megohmmeter High Tension Accessory
- BL-4002 Standing Wave Apparatus
- BL-4111 Condenser Microphone
- BL-4120 Microphone Calibration Apparatus and Accessory
- BL-4708 Automatic Frequency Response Tracer

BRUSH ELECTRONICS COMPANY

formerly
 The Brush Development Company.
 Brush Electronics Company
 is an operating unit
 of Clevite Corporation.



If you have to snoop for switch space in chassis . . .

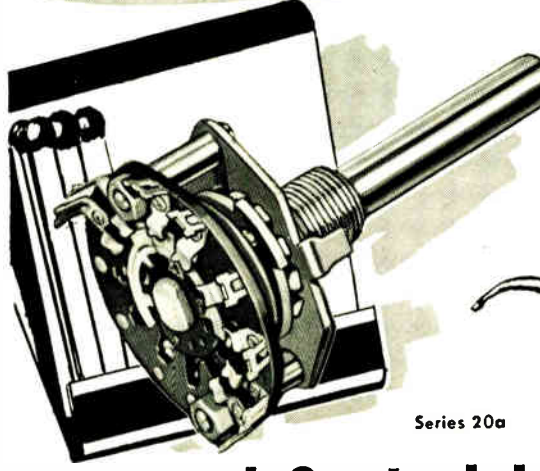

Series 20a

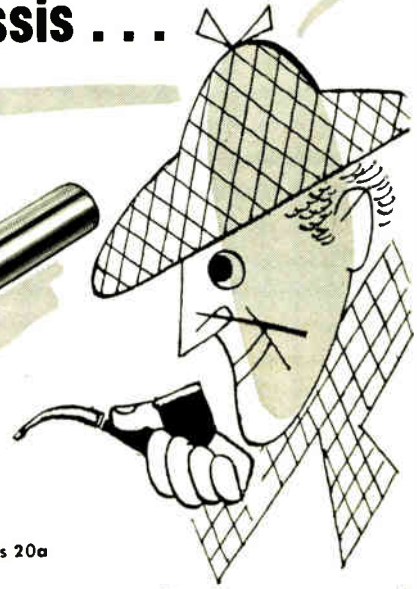

you need Centralab miniatures!

Smaller than a match book, the Centralab miniature switch you're looking at is only 1 1/2" in diameter. It's the biggest space-saving clue to new switch performance in crowded commercial or military low-power, high-frequency electronic equipment ever offered!

- Miniatures available with either steatite or phenolic sections in bolted or staked construction, and in combination with variable resistors and line switches.
- Single and multiple sections — exceptional design adaptability.
- Standard or special combinations — up to 12 positions or up to 6 poles per section.
- Steatite insulation is JAN Grade L-5 for low loss characteristics.
- Phenolic insulation—only high grades used. NEMA Grade XXXP. Mil grade P3115B.
- Indexing 30° or 60° (standard or miniature). 90° (standard only).
- Shorting and non-shorting types.
- Now available—new Series 100 Sub-Miniature for military application only (1 1/8" dia.).

Centralab has been solving switch problems for nearly 30 years!



- Centralab switches have been called the prototype of all selector switches in use today.
- Choose from the widest variety available from any manufacturer: slide, lever, rotary, power, spring-return, tone, etc. Standard items are available at your local (CRL) distributor — see Catalog 28.

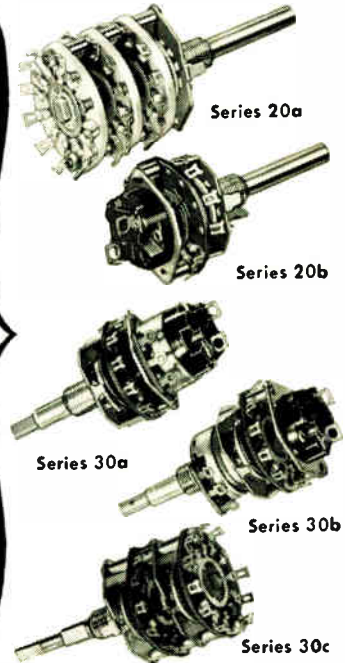

WRITE NOW FOR BULLETINS 42-156 (Series 20), 42-157 (Series 30), EP-SW-1 (Series 100).

Centralab

A Division of Globe-Union Inc.
 920-E East Keefe Avenue • Milwaukee 1, Wisconsin
 In Canada: 804 Mt. Pleasant Road, Toronto, Ontario

Industry's greatest source of standard and special electronic components

Increased Insulation
BETTER CONNECTIONS
JONES BARRIER
TERMINAL STRIPS

Leakage path is increased—direct shorts from frayed terminal wires prevented by bakelite barriers placed between terminals. Binder screws and terminals brass, nickel-plated. Insulation, black molded bakelite. Finest construction. Add much to equipment's effect.

Jones Means Proven Quality

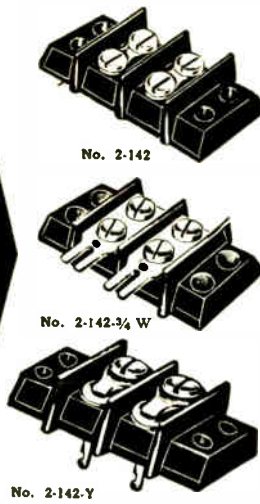

Illustrated: Screw Terminals—Screw and Solder Terminals—Screw Terminal above Panel with Solder Terminal below. Every type of connection.

Six series meet every requirement: No. 140, 5-40 screws; No. 141, 6-32 screws; No. 142, 8-32 screws; No. 150, 10-32 screws; No. 151, 12-32 screws; No. 152, 1/4-28 screws.

Catalog No. 18 lists complete line of Barrier Strips, and other Jones Electrical Connecting Devices. Send for your copy.



Jones
HOWARD B. JONES DIVISION
 CINCH MANUFACTURING CORPORATION
 CHICAGO 24, ILLINOIS
 SUBSIDIARY OF UNITED-CARR FASTENER CORP.

NEW! UHF TELEVISION
Standard Signal Generator

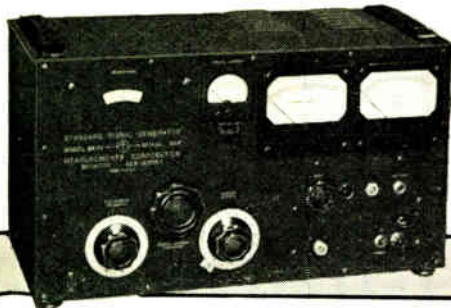

MODEL 84-TV
300—1000Mc.

SPECIFICATIONS

- FREQUENCY RANGE:** 300-1000 megacycles.
- OUTPUT:** .1 Microvolt to 1 Volt, across 50 Ohms.
- OUTPUT IMPEDANCE:** 50 Ohms coaxial.
- MODULATION:** Internal 400 cycle, continuously variable from 0 to 30%. Provision for external modulation of 50 to 20,000 cycles.
- LEAKAGE:** Negligible.
- SIZE:** Overall Dimensions: 11 3/4 inches high, 19 inches wide, 11 inches deep.
- WEIGHT:** Approximately 40 pounds.
- POWER:** 115 volts, 60 cycles, 120 watts.

Write for complete details



- MANUFACTURERS OF**
- Standard Signal Generators
 - Pulse Generators
 - FM Signal Generators
 - Square Wave Generators
 - TV Standard Signal Generators
 - Vacuum Tube Voltmeters
 - UHF Radio Noise & Field Strength Meters
 - Megacycle Meters
 - Intermodulation Meters
 - TV & FM Test Equipment

MEASUREMENTS CORPORATION
 BOONTON NEW JERSEY



(Continued from page 98A)

DETROIT

"Instrumentation," by Seymour Sterling, Sterling Instrument Company; January 22, 1954.
 "Fool Proof Electronic Control," by Stephen Hart, Electronic Control Corp.; February 19, 1954.

ELMIRA-CORNING

"Project Tinkertoy," by R. L. Henry, National Bureau of Standards; February 18, 1954.
 "UNIVAC Electronic Computers," by J. D. Chapline, Remington Rand, Inc.; March 15, 1954.

EL PASO

"Our Expanding Technology," by Dr. J. W. McRae, Sandia Corporation; February 26, 1954.

EMPORIUM

"An Electronic Micrometer for Production Measurements," by Messrs. George Chilton and Ralph West, Sylvania Electric Products, Inc.; February 25, 1954.

EVANSVILLE-OWENSBORO

"Design of Microwave Systems," by A. E. Kowitz, Motorola, Inc.; March 10, 1954.

HAMILTON

"Human Relations in Industry," by L. C. Sentance, Canadian Westinghouse Co.; January 11, 1954.
 "The Effects of Weather on the Performance of Marine Radar Over Lake Ontario," by Adam Hood, National Research Council of Canada, February 8, 1954.

HUNTSVILLE

"Tremendous Trifles," by Raymond Moeller, General Electric Company; February 16, 1954.
 "Guided Missiles Are a Must," by D. E. Mullen, General Electric Company; March 2, 1954.

INVOKERN

"The Transistor"—demonstration-lecture by Charles Develon, Pacific Telephone Company of Los Angeles; March 1, 1954.

LITTLE ROCK

"The Use of Radio in Petroleum Operations," by Dr. W. M. Rust, Jr., Humble Oil Co.; and film, "Project Tinkertoy" March 9, 1954.

LONDON

"The Production of Oscillations with Gas Tubes," by Mr. Greenwood, Student, University of Western Ontario; "Improvements in Interlacing in TV Receivers," by Mr. Southern, Student, Ryerson Institute of Technology; "The Ripple Tank as an Aid to the study of Phase Fronts," by Mr. Clark, Student, University of Western Ontario; Problems Associated with Large Scale Public Address Systems," by Mr. Godfrey, Student, Ryerson Institute of Technology; "The Electric Resistance Strain Gage," by Mr. Broughton, Student, University of Western Ontario; and "Symbolic Logic in Practice," by Mr. Hewitt, Student, University of Toronto; February 22, 1954.

"Semi-Automatic Communications," by Sqdn. Leader M. Lemke, RCAF; and "Mobile Communications in the RCAF Today," by Sqdn. Leader Fitzgerald, RCAF; March 8, 1954.

(Continued on page 102A)

See pages 161A to 164A
 for IRE Directory
 Questionnaire

New converters extend range of -hp- 524A Frequency Counter to 220 mc!

-hp- 512A Frequency Converter
10 mc to 100 mc

-hp- 524A Frequency Counter

-hp- 512B Frequency Converter
100 mc to 220 mc

- Direct readings 10 cps to 220 mc
- Increases sensitivity
- No loss in accuracy
- Instant, automatic measurement
- Easily used by non-technical personnel
- Low cost; eliminates complex setups

Now Hewlett-Packard offers two compact, economical Frequency Converters that greatly extend the range and usefulness of your -hp- 524A Frequency Counter—and MATERIALLY INCREASE SENSITIVITY WITHOUT LOSS IN ACCURACY.

The two Converters, -hp- 512A and 512B, increase Counter range from 10 to 100 mc and 100 to 220 mc, respectively. In combination with the Counter, they determine frequencies from 10 cps to 220 mc automatically, instantly, and in direct-reading form without interpolation or calculation. Complex setups and other equipment such as harmonic amplifiers, audio oscillators, multi-vibrators, search wave meters, transfer oscillators and oscilloscopes are completely eliminated. The -hp- Counter-Converter combination is readily used by non-technical personnel since operation consists merely of tuning the Converter to the unknown and selecting the measurement range.

Among the many measurements the Counter-Converter combination makes quickly and easily are crystal checking, oscillator calibration and stability, and broadcast FM and TV transmitter frequency. In addition, -hp- 524A Frequency Counter measures period of low-frequency phenomena by measuring the duration of a complete cycle in microseconds.

Data subject to change without notice. Prices f.o.b. factory.

BRIEF SPECIFICATIONS

-hp- 512A Frequency Converter

Frequency Range: As Amplifier, 100 kc to 10 mc. As Converter, 10 mc to 100 mc.

Input Voltages: 100 kc to 10 mc, 0.1 v R.M.S. minimum; 10 mc to 100 mc, 0.01 R.M.S. minimum (on 50 ohm cable).

Standard Mixing Frequency: Multiplied from 100 kc output of 524A. (Accuracy 1/1,000,000 short term.)

Output Voltage: 2 v minimum (sufficient to operate -hp- 524A over entire range).

Connectors: Standard BNC type.

Power Source: 115/230 v, 50/60 cps, 60 watts.

Size: 7" x 10 $\frac{3}{4}$ " x 14" deep. Weight 20 lbs. Rack mount available.

Accessories Furnished: Cables to interconnect with -hp- 524A.

Price: \$350.00.

-hp- 512B Frequency Converter

Same as above except Frequency Range as Converter; 100 mc to 220 mc; and Input Voltage, 0.25 v R.M.S. minimum.

WRITE TODAY FOR COMPLETE DETAILS

HEWLETT-PACKARD COMPANY

Dept. D, 3032 Page Mill Road, Palo Alto, California, U. S. A.

Field representatives in all principal areas



INSTRUMENTS

Complete Coverage

NEW "PARAFORMED" PAPER TUBES

MAKE YOUR COIL WINDING
EASIER! FASTER! BETTER!

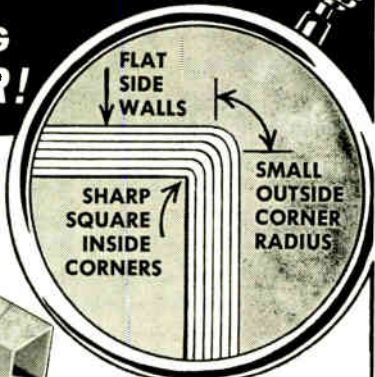

**SPIRAL WOUND
NOT DIE FORMED**

ANY SIZE—SQUARE OR RECTANGULAR

Entirely new technique in tube making developed and perfected by PARAMOUNT now for the first time solves many coil winding problems, *yet costs you no more!* Hi-Dielectric. Hi-Strength. Kraft, Fish Paper, Acetate, Red Rope or any combination wound on automatic machines. Produced from stock arbors or special sizes engineered for you.

Write on Company letterhead for Stock Arbor List of over 2000 sizes

- No sharp outside edges to cut wire
- Has full rigidity and physical strength
- Permits winding coils to closer tolerances
- No need for wedges to tighten wire
- Allows foster stacking of wound coils

PARAMOUNT PAPER TUBE CORP.

617 LAFAYETTE STREET, FORT WAYNE 2, INDIANA

Manufacturers of Paper Tubing for the Electrical Industry Since 1931

what is

available from **Pyramid**



Burton Browne advertising

The security of experience.

Pyramid has more experienced personnel (in years of actual designing and manufacturing of capacitors) than any other manufacturer.

The control of specially designed facilities. Pyramid is the only manufacturer of capacitors whose plants were planned and built specifically for the entire manufacturing process of capacitors from drawing board conception through reception of raw materials, fabrication, packaging and shipment.

The guarantee of one standard. All Pyramid capacitors are one quality, made of the same quality materials demanded by rigid military specifications. Pyramid capacitors have a low leakage factor due to the non-hygroscopic insulating material used on all production. Pyramid delivers the best at no premium.

A complete line of capacitors—full ranges in all ratings and types.



PYRAMID

ELECTRIC COMPANY

1445 HUDSON BOULEVARD • NORTH BERGEN, N. J., U. S. A.



(Continued from page 100A)

LONG ISLAND

"The Surface-Barrier Transistor," by W. H. Forster and Dr. J. B. Angell, both of Philco Corp.; February 9, 1954.

Presentation of Fellow Awards. Speaker: Prof. J. R. Ragazzini, Columbia University. Also, "The Growth of the IRE and the Importance of the Fellow Award," by J. V. L. Hogan, Hogan Labs.; March 7, 1954.

LOS ANGELES

"Geophysics and Geophysical Exploration," by M. L. Swann, United Geophysical Company; "Cinemascope and Steriophonic Sound," by Lorin Grignon, Twentieth-Century Fox Corp.; dinner speaker: "Operation Deepfreeze," by E. R. Freeto, Lockheed Aircraft, Inc.; March 2, 1954.

LOUISVILLE

"Future Sources of Power," by R. W. Ferguson, Westinghouse Electric Company; February 26, 1954.

"Project Tinkertoy or Modular Design and Mechanized Production of Electronic Mechanisms," by Dr. B. L. Davis, National Bureau of Standards; March 11, 1954.

MONTREAL

"Radio Astronomy," by A. E. Covington, National Research Council; February 24, 1954.

NEW ORLEANS

"The Advent of Television," by G. Mayoral, WJMR-TV and Jack Petrik, Supreme Broadcasting Company; March 5, 1954.

NEW YORK

"Solid State Amplifiers," by Ernst Weber, Polytechnic Institute of Brooklyn; March 3, 1954.

NORTH CAROLINA-VIRGINIA

"NTSC Color Television Standards," by C. J. Simon, General Electric Company; March 5, 1954.

OMAHA-LINCOLN

Demonstration and discussion of the Scotchlock Wire Connectors and the resin products, by E. W. Bollmeir, Electro-Mechanical Products; discussion and demonstration of sound recording tape, by R. A. Von Behren, Magnetic Products Lab.; February 18, 1954.

OTTAWA

"Method for Time or Frequency Compression—Expansion of Speech," by Dr. W. L. Everitt, Dean, University of Illinois College of Engineering; February 18, 1954.

"Built-In Brains," by W. J. Turnbull, Deputy Postmaster General of Canada; March 11, 1954.

PHILADELPHIA

"Ferroelectric Storage Devices," by J. R. Anderson, Bell Telephone Labs.; February 9, 1954.

"Magnetic Drums and Tapes," by J. Rabinow and S. N. Alexander, National Bureau of Standards; February 16, 1954.

"Ferromagnetic Storage Devices," by T. H. Bonn, Remington Rand, Eckert Mauchly Division; February 23, 1954.

"Studio and Remote Pickup Equipment," by J. H. Roe, RCA; February 25, 1954.

"Electrostatic Storage Devices," by J. H. Pomerene, Institute for Advanced Study; March 2, 1954.

(Continued on page 103A)



(Continued from page 102A)

"Acoustic Storage Devices," by J. F. Koch, Jr., Technitrol Engineering Co. Inc.; March 9, 1954.

"Film Problems in Color TV," by A. N. Goldsmith, Chairman, NTSC Panel II; "Color TV From Film," by E. H. Traub, Philco Corp.; "Color Signal Recording Techniques," by E. D. Goodale, N.B.C.; and "Network Transmission of Color Signals," by J. R. Rae, American Tel. and Tel. Company; March 11, 1954.

"Summary and Evaluation," by A. L. Samuel, IBM Corp.; March 16, 1954.

"Techniques of Color Broadcasting," by R. A. Monfort, N.B.C.; "Transmitter Specifications," by T. M. Gluyas, RCA; and "Specially Developed Test Equipment and Test Methods," by J. W. Wentworth, RCA; March 19, 1954.

PITTSBURGH

Inspection Trip of Bell Telephone 4A Toll Switching System, Automatic Message Accounting Center, and TV Control Center. This was a Joint Meeting with AIEE, Engrs. Soc. of W. Pa.; March 9, 1954.

ROME-UTICA

"Packaging of Speech Communications by Means of Pre-Emphasis and Peak Clipping Methods," by Dr. Oliver Straus, National Company; March 2, 1954.

SACRAMENTO

"Television Station Equipment," by Harry Bartolomei, KCCC-TV; February 26, 1954.

"Color Television Systems," by W. E. Evans, Stanford Research Institute; March 12, 1954.

(Continued on page 104A)

NEED INSTRUMENTS TO SOLVE ELECTRONIC PROBLEMS?

RADA-SWEEP
Radar IF Amplifier Alignment

MARKA-SWEEP RF-P
TV Tuner Alignment

WRITE FOR FACTS

MEGA-MATCH
Measurement of Reflection Coefficient

RADA-PULSER
Radar IF Transient Testing

ELECTRONIC INSTRUMENTS

MEGA-PULSER
Transient Testing Video Amplifiers

CALIBRATED MEGA-SWEEP
Wide Range Sweeping Oscillator Single Dial Tuned

CONSULT THIS LATEST CATALOG FOR THESE AND NUMEROUS OTHER INSTRUMENTS

KAY ELECTRIC CO.

14 MAPLE AVE.
PINE BROOK, N. J.

Class Your Cabinets with THESE...

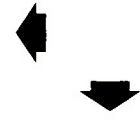

**R & T
aluminum
sheet metal
cabinets for
RADIST
SYSTEMS**

Can they meet R & T Quality, Service or Production Economies?

You can see the quality built into these aluminum cabinets for the Hasting Instrument Co. What doesn't show is the durability and extra service delivered by Riester and Thesmacher's 50 years of expert craftsmanship in sheet metal fabrications . . . or the production economies made possible by R & T's complete modern facilities. Whether yours is a problem of design or production—for large orders or small—you are assured of its thorough analysis and a prompt quotation from R & T.

- ▶ Aluminum Spot Welding
- ▶ Hellarc Aluminum Welding

• REPRESENTED BY •

Frank W. Taylor Co. P.O. Box 316, DeWitt, N.Y.	Paul R. Sturgeon 25 Huntington Ave., Boston 16, Mass.
Kenneth E. Hughes Co. 4808 Bergenline Ave., Union City, N.J.	Samuel K. Macdonald, Inc. 1531 Spruce St., Philadelphia 2, Pa.
William E. McFadden 150 Broad St., Columbus 15, Ohio	Southeastern Sales Co. Georgia Savings Bank Bldg., Atlanta, Ga.



MANUFACTURERS
Special Steel Equipment
Metal Cases - Cabinets
CONTRACTORS
Sheet Metal
Building Products
VENTILATION,
AIR CONDITIONING

**THE
RIESTER & THESMACHER
COMPANY**

1526 W. 25TH ST.
CHERRY 1-0154

CLEVELAND, OHIO

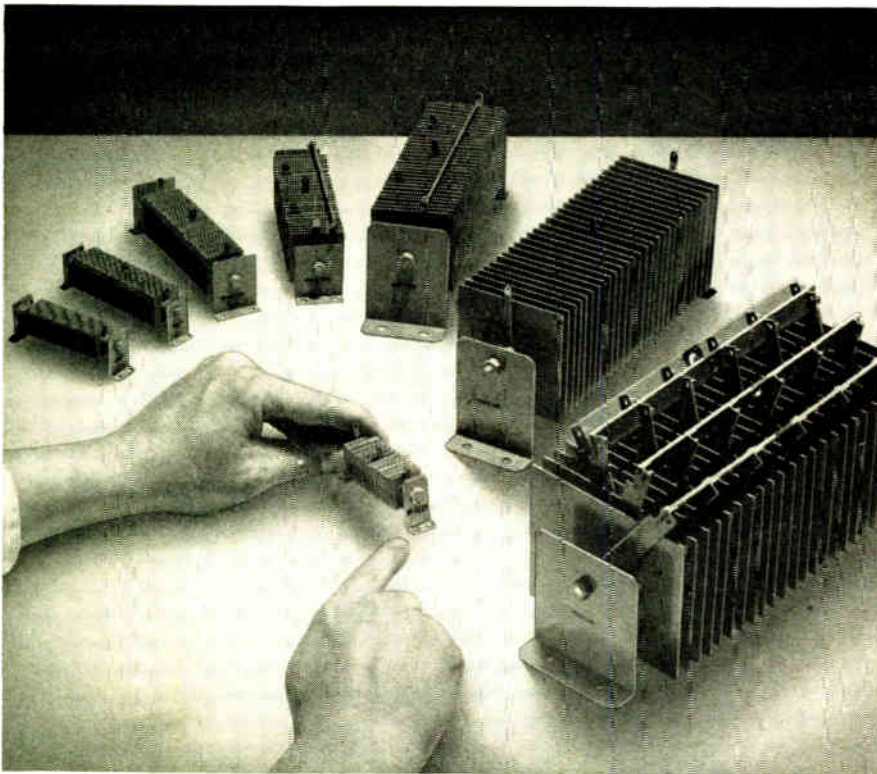

STACKS OF STABILITY

Bradley rectifiers invariably exceed performance requirements, but this quality bonus does not carry a premium price. Our exclusive vacuum process not only assures stability and long life; it also assures low cost. We would like to prove it by quoting now on your rectifier needs. Please fill out the form below — you'll get quick action.

VACUUM PROCESSED — for performance *cs* rated

BRADLEY LABORATORIES, INCORPORATED
170P COLUMBUS AVE., NEW HAVEN 11, CONN.



DC Output: Volts Min. _____ Amperes Max. _____ Circuit _____	FINISH REQUIRED: _____
AC Input: Volts Max. _____ Phase _____	QUANTITY: _____
LOAD: Res. _____ Ind. _____ Cap. _____ Battery _____	NAME _____
DUTY: Continuous _____ Intermittent _____ On _____ Off _____	ADDRESS _____
COOLING: Convection _____ Forced _____ Ft. Per Min. _____	_____
Max. Ambient Temp. _____ °C	_____



(Continued from page 103A)

SAN DIEGO

"Two Large-Scale Real-Time Computers," by Stanley Rogers, Consolidated Vultee Aircraft Corp.; March 9, 1954.

SYRACUSE

"Application of Correlation Function to Communications Problems," by Dr. R. E. Johnson, Syracuse University; February 4, 1954.

"Operations Research," by Sherman Kingsbury, Arthur D. Little, Inc.; February 23, 1954.

TULSA

"The Application of Matrix Algebra to Circuit Analysis," by R. N. Norman; "An Electronic Ignition System," by E. M. Barnes, Jr.; and "Can The Yagi Antenna Solve Your TV Reception Problem?" by T. B. Hall, all Students; March 11, 1954.

TWIN CITIES

"Problems in the Development of a Power Transistor," by Dr. Van W. Bearinger, Minneapolis-Honeywell; March 10, 1954.

VANCOUVER

"Theoretical Considerations in the Correction of Loudspeaker Distortion," by P. G. Scott; "The FTL-14 Direction Finder," by G. E. Forman; and "Distributed Amplifiers," by W. R. Tracy, all Students, University of B. C.; February 15, 1954.

WASHINGTON

"Matching Opportunity with Need," by J. W. McRae, Sandia Corporation; March 8, 1954.

WINNIPEG

"Manitoba Power Commission VHF Radio System," by E. H. Edge, Rogers-Majestic Electronics Ltd.; and "Microwave Systems," by T. G. Lynch, Canadian General Electric Co. Ltd.; March 2, 1954.

SUBSECTIONS

AMARILLO-LUBBOCK

"Application of Symbolic Logic in Design of Switching Circuits," by W. G. Breckenridge, Student winner of annual paper contest; January 26, 1954.

ITHACA

"Photoconductivity," by Albert Rose, RCA Labs.; January 22, 1954.

LANCASTER

"Transistor Circuit Applications," by L. G. Schimpf, Bell Telephone Labs; March 10, 1954.

MID-HUDSON

"Construction, Characteristics and Performance of Capacitors in Conventional and High Reliability Circuits," by D. B. Peck, Sprague Electric Company; February 18, 1954.

MONMOUTH

"Kodachrome Travelogue of Europe," by G. W. Crawford, RCA Victor; February 17, 1954.

NORTHERN NEW JERSEY

"Electronic Digital Computers," by Dr. J. W. Mauchley, Remington Rand, Inc.; February 10, 1954.

TUCSON

"Transistors and Their Applications," by Tudor Finch, Bell Labs.; February 12, 1954.

USAFIT

"Applications of Transistors," by R. D. Alberts, Aircraft Radiation Lab.; February 26, 1954.

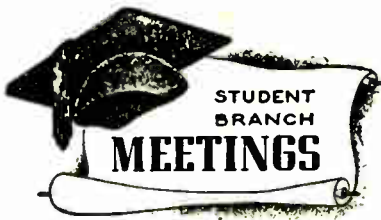

ALABAMA POLYTECHNIC INSTITUTE, IRE BRANCH
General meeting; February 22, 1954.

BROWN UNIVERSITY, IRE-AIEE BRANCH
General meeting; February 17, 1954.

UNIVERSITY OF CALIFORNIA, IRE-AIEE BRANCH
Executive Committee meeting; February 16, 1954.

General meeting; February 23, 1954.
Executive Committee meeting; March 2, 1954.
"Our Interesting Universe," by Dr. L. Reukema, Faculty, University of California; March 5, 1954.

"Transistors,"—demonstration by Ray Tiffany, Pacific Telephone; March 15, 1954.

Business meeting; March 16, 1954.

"The Swindletron"—talk and demonstration by Prof. J. Woodyard, University of California; March 19, 1954.

CALIFORNIA INSTITUTE OF TECHNOLOGY,
IRE BRANCH

"High Frequency Heating," by W. A. Dent, Westinghouse Electric Corp; February 8, 1954.

CALIFORNIA STATE POLYTECHNIC COLLEGE,
IRE BRANCH

"Engineering at Hewlett-Packard," by Noel Porter, Hewlett-Packard; "100 Megacycle Counter," by R. W. Forsblad and D. L. Palmer, Hewlett-Packard; March 4, 1954.

CARNEGIE INSTITUTE OF TECHNOLOGY,
IRE-AIEE BRANCH

Film, "Voices in Paper" and Talk, "Position Interviews," by O. P. Robinson, Cutler-Hammer Company; December 10, 1953.

"The Future of the Electric Power Industry," by A. C. Montieth, Westinghouse Electric Corporation, December 16, 1953.

Election of officers; February 19, 1954.

CASE INSTITUTE OF TECHNOLOGY, IRE BRANCH

"Electronics in Nuclear Physics," by Prof. E. C. Gregg, Faculty, Case Institute of Technology; March 23, 1954.

COLORADO A & M COLLEGE, IRE-AIEE BRANCH

General meeting and film, "Steels Party Line"; February 17, 1954.

"History of AIEE," by Albert Anderson, AIEE and General Electric; March 3, 1954.

COLUMBIA UNIVERSITY, IRE-AIEE BRANCH

Business meeting; February 25, 1954.

UNIVERSITY OF CONNECTICUT, IRE-AIEE BRANCH

"Automatic Pilots," by E. J. Isbister, Sperry Gyroscope Company; January 14, 1954.

UNIVERSITY OF DAYTON, IRE-AIEE BRANCH

General meeting; January 5, 1954.

Talks by C. Marshall, Regional Director; A. Petit and A. B. Henderson, Chairman and Vice Chairman of the Dayton Section, and John Heyt, member of Professional Group, Dayton Section; February 11, 1954.

"Ionosphere and Its Effect on Radio Waves," by Wilbur Chang, Student; February 18, 1954.

"Color Television," by Mr. Dominic, Student; February 25, 1954.

(Continued on page 106A)

105A

BEST ALL-AROUND TESTER ON THE MARKET

TEST FOR:

- TV SETS
- RADIOS
- TRANSMITTERS
- BROADCASTING EQUIPMENT
- HOME APPLIANCES
- TWO-WAY RADIO COMMUNICATING SYSTEMS
- PHONE LINES
- AIR CONDITIONING SYSTEMS
- STARTER CONTROLS
- AUTO IGNITIONS, GENERATORS, BATTERIES
- MOVIE EQUIPMENT
- PANEL INSTRUMENTS
- TV CAMERAS
- AUTO LIGHTING SYSTEMS
- GENERATORS
- VOLTAGE SOURCES
- "HAM" RADIO EQUIPMENT
- CABLES
- CONNECTORS
- AUDIO FREQUENCY SOUND CURRENTS

...and write for your complimentary copy of
"1001 Uses for the Simpson Model 260"
50 pages of uses.

RANGES:

2500 OHMS PER VOLT DC
1500 OHMS PER VOLT AC
VOLTS, AC AND DC 2.5, 10, 50, 250, 500, 1000
OUTPUT: 2.5, 10, 50, 250, 500
MILLIAMPERES, DC: 25, 50, 100
MILLIAMPERES, AC: 100
AMPERES, DC: 10
RESISTANCE RANGES: —11 TO 415 OHM
OHMS, 5-200 (13 OHMS CENTER), 5-20,000 (1,200 OHMS CENTER), 5-20 MEGOHMS (125,000 OHMS CENTER)



Simpson
Model 260
VOLT-OHM-MILLIAMMETER

525.90 Dealer's net.

SIMPSON ELECTRIC COMPANY

5200 N. Kinzie St., Chicago 44 - Elmhurst 9-1121

In Canada: Bach-Simpson, Ltd., London, Ont.

World Radio History

MICROWAVE FREQUENCY METER 810

8,200 mc to 12,400 mc

The NARDA model 810 Frequency Meter is a cylindrical cavity type resonator mounted on a section of $1 \times \frac{1}{2}$ waveguide. The cavity is tuned over the complete range by a precision micrometer drive with a vernier which may be read to 0.0001 inch. A calibration table is mounted on the cavity. A reactive dip of at least 10% is obtained at all frequencies in the range. There are no spurious responses or other ambiguities.

SPECIFICATIONS:

Accuracy:	0.1%	\$110.00 FOB.
Precision:	0.02%	
Loaded Q:	7000	
Reactive dip:	10% min.	

NEW IMPROVED BOLOMETERS



Detailed catalog sheet RA-3 on request

APPLICATIONS:

Microwave power measurement · Square Law detection · VSWR detection · Attenuator calibration.

FEATURES:

- N-610B INTERCHANGEABLE with IN21 and IN23 crystals in all tuneable probes, waveguide and coaxial crystal detectors.
- STANDARDIZED BIAS—8.75 ma. for 200 ohms.
- HIGHER BURNOUT RATING—15 mw of rf at rated bias.
- RUGGEDIZED—soldered contacts and improved construction.
- N-821B INTERCHANGEABLE in all barretter mounts.
- RUGGEDIZED CONSTRUCTION.
- Silver contacts and continuous copolymerstyrene sleeve.
- STANDARDIZED BIAS—8.75 ma for 200 ohms.

Write for NARDA Catalog RC-3—a COMPLETE line of microwave test equipment. *Price in U.S.

NARDA NASSAU RESEARCH & DEVELOPMENT ASSOCIATES INCORPORATED
66 MAIN STREET · MINEOLA, NEW YORK · GARDEN CITY 3-3570

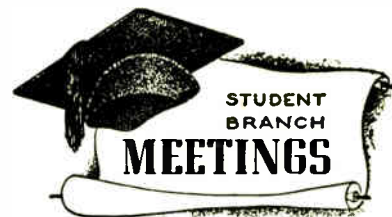

(Continued from page 105-A)

UNIVERSITY OF DELAWARE, IRE-AIEE BRANCH

- "Customer Toll Dialing," by W. F. Denkhause, Plant Extension Engineer; January 13, 1954.
- "Scientific Training in United States and Europe," by Dr. W. A. Mosher, Faculty, University of Delaware; January 18, 1954.
- "Professional Registration for the Engineer," by Dean D. L. Arm, University of Delaware; March 1, 1954.

FENN COLLEGE, IRE BRANCH

- Business meeting; January 26, 1954.
- Business meeting and election of officers; February 14, 1954.

UNIVERSITY OF FLORIDA, IRE-AIEE BRANCH

- "Flying Saucers," by C. B. Searles, Vice Chairman of the Student Branch; film, "Hidden World"; February 21, 1954.
- General meeting and election of officers; March 8, 1954.

GEORGE WASHINGTON UNIVERSITY, IRE BRANCH

- Quiz of six selected members for prize sponsored by Washington Section; March 3, 1954.

UNIVERSITY OF ILLINOIS, IRE-AIEE BRANCH

- General Electric exhibit "House of Magic" with W. R. Whitmore and Richard Bogh, of General Electric; election of officers; February 24, 1954.
- "Military Electronics at Bell Labs.," by W. H. C. Higgins, Bell Telephone Labs.; March 10, 1954.

STATE UNIVERSITY OF IOWA, IRE BRANCH

- "Collins Intergrated Flight System," by Mr. Westcott, Collins Radio Company; IRE Paper Contest; March 3, 1954.

KANSAS STATE COLLEGE, IRE BRANCH

- "Use of Precision Snap-Acting Switches in Safety Applications," by A. L. Riche, Micro Switch; February 25, 1954.
- "Production of Synthetic Crystals for Telephone Work," by Fred Masek, Bell Telephone Labs.; March 11, 1954.

LAFAYETTE COLLEGE, IRE-AIEE BRANCH

- "Sales Engineering," by Howard Lovett, of Roller Smith; January 11, 1954.
- "Electronic Umpire," by Richard Soiler, Student, Lafayette College; February 29, 1954.

LEHIGH UNIVERSITY, IRE BRANCH

- "The College Graduate in Public Utilities.," by W. Astley, Philadelphia Electric Company; February 18, 1954.

UNIVERSITY OF MARYLAND, IRE-AIEE BRANCH

- Demonstration: TV and Micro Wave Equipment, by Robert Gish, Philco Corp.; March 10, 1954.

MASSACHUSETTS INSTITUTE OF TECHNOLOGY, IRE-AIEE BRANCH

- "Color Television," by C. N. Hoyler, David Sarnoff Research Labs., RCA; March 9, 1954.

MICHIGAN STATE COLLEGE, IRE-AIEE BRANCH

- Election of officers; March 3, 1954.

(Continued on page 108-A)

ALLIED world's largest distributor of ELECTRON TUBES FOR INDUSTRY

ALL BRANDS
IN STOCK
AMPEREX
G.E.
EIMAC
RCA
RAYTHEON
SYLVANIA
TAYLOR
TUNGSOL
VICTOREEN
WESTINGHOUSE
and others

IMMEDIATE DELIVERY FROM STOCK

ALLIED stocks for quick shipment the world's largest distributor inventory of special-purpose electron tubes. We specialize in supplying the needs of industrial, broadcast, governmental and other users. To save time, effort and money—phone, wire or write to ALLIED for fast expert shipment.

Refer to your ALLIED Catalog for all electronic supplies. Write today for a FREE copy of the complete 268-page 1954 ALLIED Catalog.



ALL TYPES
IN STOCK
Power Tubes
Rectifiers
Phototubes
Radiation
Sub-Miniature
Oscillograph
Transistors
Ignitrons
Thyratrons
Image Orthicon
Klystron
All Special
Purpose Tubes

Everything in
Electronics from
One Dependable Source

ALLIED RADIO

100 N. Western Ave.
Dept. 35-E-4, Chicago 80, Ill.

CANNON
Sub-Miniature
PLUGS

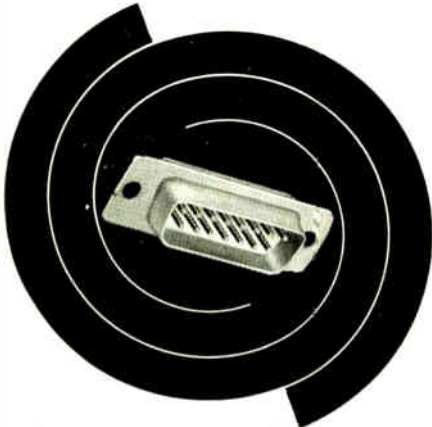

TYPE "D" . . . UP TO 50 CONTACTS

For Your Miniaturization Program!

Save space . . . save weight . . . rugged. 1000's of uses! Pressed steel shells. Heavily gold-plated copper-alloy 5-amp. contacts give untarnishing high surface conductivity and corrosion resistance. Take #20 solder-tipped wires. Polarization means. Salt-spray resistant shells. Flashover 1700v dc.

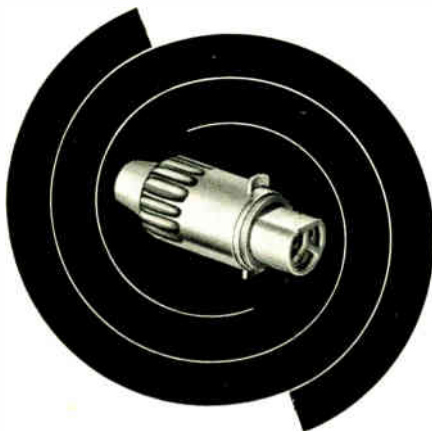

TYPE "U" . . . UP TO 12 CONTACTS

Receptacles Hermetically-sealed

Round steel shells. Pin receptacles have fused vitreous insulators to give true hermetic seal. Adaptable to box-or panel-mounting. Pin or socket plugs have resilient moisture-sealing insulators, gold-plated contacts. Bayonet latch. Cord connectors have resilient sleeves. Contacts 5-amp. Flashover 1700v dc.

Write for Cannon Sub-Miniature Bulletins . . . TODAY! Refer to Dept. 377

CANNON ELECTRIC COMPANY, 3209 Humboldt St., Los Angeles 31, Calif. Representatives and Cannon distributors in all principal cities.



Since 1915

CANNON ELECTRIC

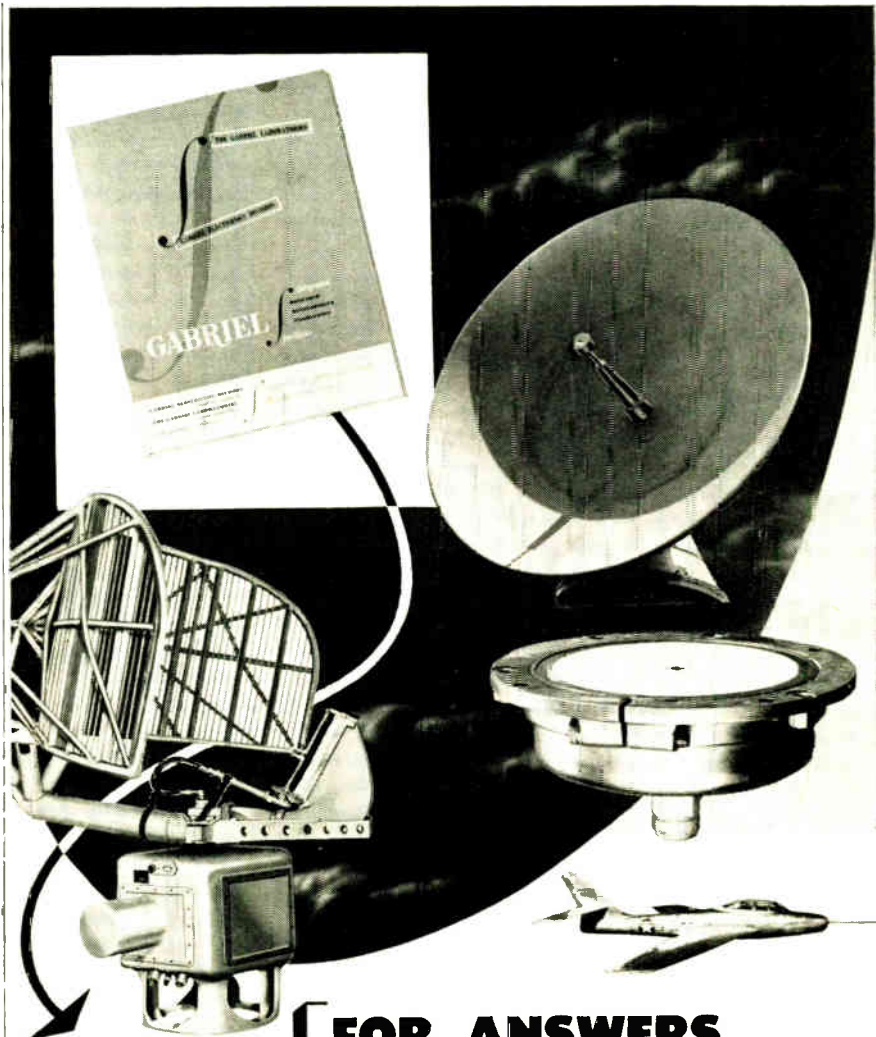

Look here **FOR ANSWERS TO YOUR* ANTENNA PROBLEMS**

Facing new antenna problems?

Find important new ideas and advanced techniques leading to the ultimate answers in Gabriel's new Facilities Report. For design . . . development . . . or production, you need this 24-page well illustrated brochure.

It is, we believe, by far the most complete in the field. A few of the projects described — typical of Gabriel experience that can help you — are:

RADAR — Design and production of search antennas; IFF parasitic antennas; conical scan for gunlaying and tracking.

MISSILES — Flush-mounted antennas for intelligence transmission; beacon antennas for tracking.

AIRCRAFT — Blade, flush mounted, and block antennas for navigational radar, Shoran, communications, and homing.

MICROWAVE RELAY — For mobile military communications, railroad, TV network, and public utilities.

*Executives and Engineers at Management Level.

SEND FOR YOUR COPY. Write on your letterhead, please, indicating antenna problem involved. Address Consulting Engineering Department.

GABRIEL ELECTRONICS DIVISION

Formerly Workshop Associates Division

THE GABRIEL COMPANY, 300 Endicott Street, Norwood, Mass.



a little more of everything

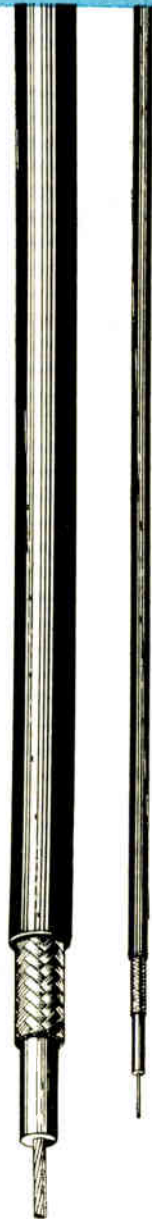
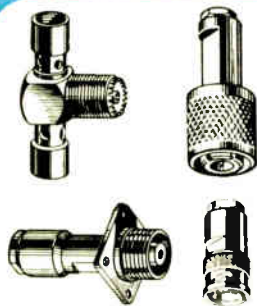

Yes, in a way, a second helping—for we are trying to express the factors which have helped raise the **AMERICAN PHENOLIC CORPORATION** by its boot straps in a little over twenty years. In the early thirties **AMPHENOL** was just another struggling industrial infant in one small factory and our main concern then was radio sockets. Today there are five modern plants producing over 11,000 cataloged products ranging all the way from AN connectors to television antennas.

"A little more of everything"—we think a little more courage, a little more imagination, a little more faith have been responsible for the growth of **AMPHENOL** during the last two decades. And we look forward to the same "little more" qualities, a second helping of the same, to keep **AMPHENOL** a vital member of the electronics industry for many, many years to come.

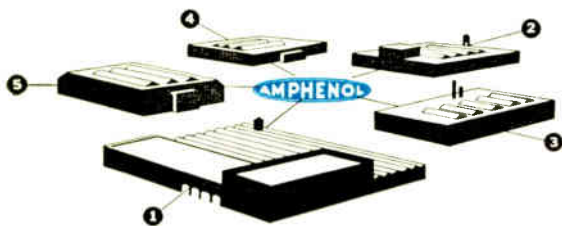

AMERICAN PHENOLIC CORPORATION

chicago 50

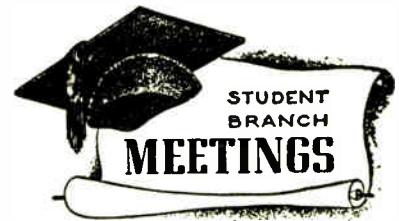

(Continued from page 106A)

UNIVERSITY OF MINNESOTA, IRE-AIEE BRANCH
 "What Can Computers Do For You," by P. N. Hess and D. W. Fenne, University of Minnesota Computing Center; February 3, 1954.

Inspection Trip to Minneapolis-Honeywell Company Research Lab.; February 18, 1954.

"Problems in the Development of a Power Transistor," by Dr. Van W. Bearinger, Minneapolis-Honeywell Regulator Company; March 10, 1954.

MISSOURI SCHOOL OF MINES & METALLURGY, IRE-AIEE BRANCH

General meeting and films, "The Microwave Oscillator" and "The Atom Goes to Work"; February 25, 1954.

MONTANA STATE COLLEGE, IRE-AIEE BRANCH

"Street Lighting," by Mr. Graff, General Electric Company; February 8, 1954.

"Television Broadcasting and Receiving," by R. C. Seibel, Faculty, Montana State College; February 25, 1954.

"Power Systems Analyzer," by J. F. Fuller, General Electric Company; March 4, 1954.

NEW MEXICO COLLEGE OF A & M ARTS, IRE-AIEE BRANCH

"What Management Expects of New Employees," by Jack Bowen, El Paso Electric Company; February 11, 1954.
 Election of officers; March 12, 1954.

COLLEGE OF THE CITY OF NEW YORK, IRE BRANCH

General meeting; February 11, 1954.
 "Digital Computers," by Donald Rosenheim, IBM; February 18, 1954.

"Regulating Systems," by Mr. Redmon, Westinghouse Electric Corp.; February 25, 1954.

"Problems in Power Generation," by M. F. Kent, General Electric Company; March 4, 1954.

"Wave Guides," by A. C. Beck, Bell Telephone Labs.; March 18, 1954.

UNIVERSITY OF NORTH DAKOTA, IRE-AIEE BRANCH

General meeting and film on transistors; March 10, 1954.

OKLAHOMA A & M COLLEGE, IRE-AIEE BRANCH

"Suicide of a High Voltage Arc," by G. H. Mahke, Line Material Company; February 18, 1954.

Student paper competition: "The Application of Matrix Algebra to Circuit Analysis," by R. N. Norman; "An Electronic Ignition System," by E. M. Barnes, Jr.; and "Can the Yagi Antenna Solve Your TV Reception Problem?" by T. B. Hall; March 11, 1954.

"Mechanized Intelligence," by W. Keister, Bell Telephone Labs.; Election of officers; March 15, 1954.

OREGON STATE COLLEGE, IRE BRANCH

Film, "Prelude to Kitimat"; March 2, 1954.

UNIVERSITY OF PENNSYLVANIA, IRE-AIEE BRANCH

Election of officers; February 12, 1954.

General meeting; February 21, 1954.

"The Physics of Music and Hearing," by Dr. W. E. Koch (on tapescript), Bell Telephone Laboratories; February 24, 1954.

"Electric Cardiology," by E. Frank, Faculty, Moore School of Elec. Eng'g.; March 8, 1954.

"Radiology," by Dr. S. R. Warren, Jr., Asst. Vice Pres. in Charge of Undergraduate Affairs; March 15, 1954.

(Continued on page 110A)

IN ITS 21 TOWER MICROWAVE SYSTEM

Western Union uses Sperry Klystrons

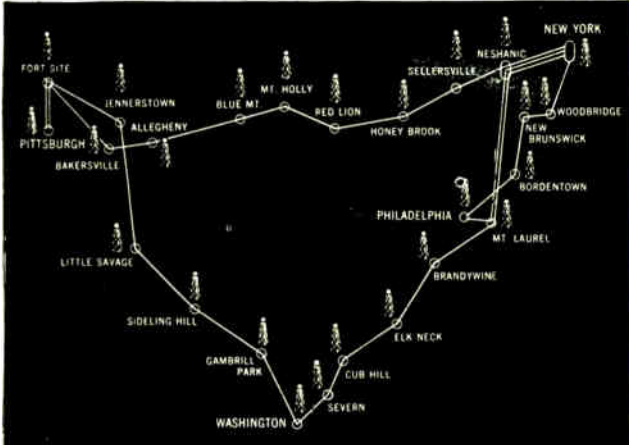

“Dependability has been excellent,” writes H. P. Corwith, Vice President, Development and Research. “Average tube life has been more than 15 months, and some tubes have been in continuous service for almost 3 years.”

■ Installed in 1948, the Western Union microwave system between New York, Philadelphia, Washington and Pittsburgh, consists of 21 towers, varying in height from 60 to 120 feet, and spaced up to 55 miles apart. The system handles hundreds of telegraph circuits—including important government and leased private wire systems as well as circuits for regular message traffic.

■ Through the use of Sperry SAC-41 Klystrons providing power output of 10 watts, Western Union has effectively reduced circuit outages due to fading, and provided dependable service under all conditions. Furthermore, as Mr. Corwith points out above, the average life of Sperry SAC-41 Klystrons has been 15 months—and some tubes have served continuously for almost 3 years.

■ Since 1938, when Sperry sponsored the development of the Klystron, this Company has extended its application to tubes for low, medium and high power applications—and in a frequency range from 750 to 40,000 megacycles. The research, development and specialized production facilities of Sperry in Klystrons — and in accompanying Microline* equipment—are at your disposal to help in solving your problem.

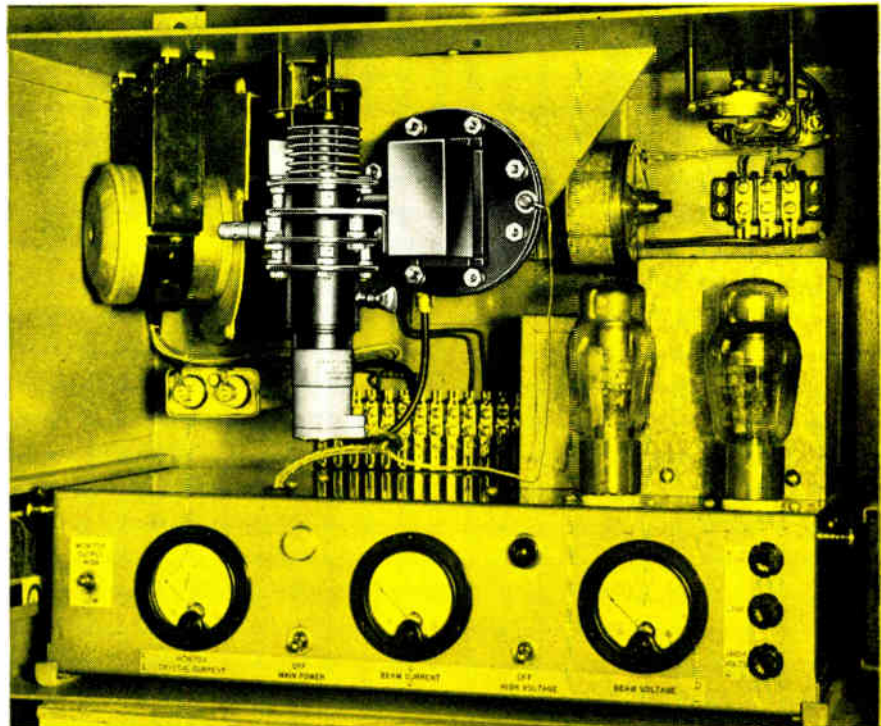

*T.M. REG. U.S. PAT. OFF.

SPERRY *GYROSCOPE COMPANY*
DIVISION OF THE SPERRY CORPORATION

GREAT NECK, NEW YORK • CLEVELAND • NEW ORLEANS • BROOKLYN • LOS ANGELES • SAN FRANCISCO • SEATTLE
IN CANADA • SPERRY GYROSCOPE COMPANY OF CANADA LIMITED, MONTREAL, QUEBEC

PROCEEDINGS OF THE I.R.E. May, 1954

109A

Specification Coils

—for every requirement—radio, FM, TV and Government Applications!

Including Universal, Bank Wound, Universal Progressive and Solenoid. All are precision-built to highest engineering standards and conform exactly to specifications. For uniform high quality, prompt delivery and economical unit costs, specify coils by Fugle-Miller. Radio, TV and JAN specifications are a specialty. Phone, wire or write for quotations.

ADDRESS INQUIRIES TO DEPT. P-5

FUGLE-MILLER LABORATORIES
 MAIN STREET, METUCHEN, NEW JERSEY
 Telephone: Metuchen 6-2245

SECON

- round •
- oval
- flat •
- grooved
- ribbon •

precision small wire

- bare •
- insulated
- plated •

for highly engineered applications

- all metals •
- all alloys

Round Wire to 0.00015" diameter. Ribbon rolled to 0.0001" in thickness. Close tolerances held on all specifications.

SECON
 ... wherever the element calls for PRECISION

development and production metallurgists
SECON METALS CORPORATION
 7 Intervale Street, White Plains, New York
 White Plains 9-4757

Write for Pamphlet P



(Continued from page 108A)

RENSELAER POLYTECHNIC INSTITUTE,
IRE-AIEE BRANCH

"Engineering Considerations in the Design of Nuclear Power Reactors," by K. A. Kesselring, Knolls Atomic Power Lab.; film, "A is for Atom"; February 16, 1954.

UNIVERSITY OF RHODE ISLAND, IRE-AIEE BRANCH
General meeting; March 17, 1954.

RUTGERS UNIVERSITY, IRE-AIEE BRANCH
"Color Television," by Dr. Brown, RCA Labs.; February 4, 1954.

"Amateur Radio and Civil Defense," by R. Forsyth, Civil Defense; February 18, 1954.

Talk by Messrs. Woody and Frick, Westinghouse Electric Corp.; February 19, 1954.

Election of officers; March 4, 1954.
Field trip through New Jersey Bell Tel. Co., conducted by Robert Miller; March 17, 1954.

SAN DIEGO STATE COLLEGE, IRE BRANCH
Film, "Germanium, the Magic Metal"; March 16, 1954.

UNIVERSITY OF SOUTHERN CALIFORNIA,
IRE-AIEE BRANCH

"The Training Program of General Electric," by Walter Scott, General Electric Company; March 3, 1954.

"The Ground Approach Control for Aircraft," by E. R. Swanson, Gillfillen Radio Corporation; March 10, 1954.

STANFORD UNIVERSITY, IRE-AIEE BRANCH
"Some Circuit Properties of Junction Transistors,"—Bell Telephone Lab. Tapescript; February 25, 1954.

TEXAS TECHNOLOGICAL COLLEGE,
"The Practical Aspects of Engineering," by Bob Wilson, Electrical Dept. of the City of Lubbock; March 1, 1954.
Election of officers; March 15, 1954.

UNIVERSITY OF TOLEDO, IRE-AIEE BRANCH
General meeting; January 13, 1954.
General meeting; March 3, 1954.

UNIVERSITY OF TORONTO, IRE-AIEE BRANCH
Student night sponsored by Toronto Section. Papers presented: "Symbolic Logic Applicable to Switches," by A. Hewitt; "Cathode Interface Resistance," by R. E. Hobson; "Ground Approach Control," by R. Richardson; and "Transistors," by R. Charette; February 15, 1954.

"Engineering Related to Microwave, Broadcast and T.V. Equipment," by R. A. Muller, Canadian General Electric Company; February 19, 1954.

"Voltage Regulators," by F. M. Squires, Ferranti Electric Ltd.; February 26, 1954.

"Design and Application of Electronic Computers," by Mr. Aitchison, IBM Co. Ltd.; film, "Piercing the Unknown"; March 5, 1954.

Two films, "Wires Under Water" and "Manufacture of Paper Insulated Cables." Speaker: H. C. Graham, Northern Electric Co. Ltd.; March 12, 1954.

UNIVERSITY OF UTAH, IRE-AIEE BRANCH
"Unified Engineering Program," by A. D. Hill Student, University of Utah; February 2, 1954.
Business meeting; February 9, 1954.
Film, "Okenite Plant"; February 16, 1954.

(Continued on page 112A)

BE SAFE WITH
Q-max
A-27
LOW-LOSS LACQUER & CEMENT

- Q-Max is widely accepted as the standard for R-F circuit components because it is chemically engineered for this sole purpose.
- Q-Max provides a clear, practically loss-free covering, penetrates deeply, seals out moisture, imparts rigidity and promotes electrical stability.
- Q-Max is easy to apply, dries quickly and adheres to practically all materials. It is useful over a wide temperature range and serves as a mild flux on tinned surfaces.
- Q-Max is an ideal impregnant for "high" Q coils. Coil "Q" remains nearly constant from wet application to dry finish. In 1, 5 and 55 gallon containers.

Communication Products Company, Inc.
 MARLBORO, NEW JERSEY (MONMOUTH COUNTY)
 Telephone: FReehold 8-1880 

The RIGHT Coated Fabric for YOU



Over the years, leading manufacturers have learned to rely upon APEX when selecting durable, fast colored, sales-improving fabrics for:

- PORTABLE PHONOGRAPHS
- PORTABLE RADIOS
- TAPE RECORDERS
- TV BOOSTERS
- SERVICING KITS
- ANTENNA ROTATOR CONTROL CABLES
- SERVICEMEN'S CARRYING CASES
- PORTABLE PA SYSTEMS
- PORTABLE TV SETS
- TEST INSTRUMENTS
- SOUND & PROJECTION EQUIPMENT
- INDUSTRIAL & MEDICAL EQUIPMENT

It will cost you nothing to let APEX specialists consider your problems.



APEX COATED FABRICS, Inc.
 16 East 22nd St. N. Y. City 10
 Phone: SPring 7-3140

For 28 years "The House of Service"

No. 1
 in a
 series

design progress through
 inter-company co-operation

... coordinated by *Airtron inc.*



**MINIATURIZED
 RADAR PLUMBING...**
plus greater power and band width!

Recently, Airtron was confronted with a difficult problem — how to develop a radar plumbing system that was greatly reduced in size and weight, yet capable of handling higher power and wider band width. The solution not only necessitated redesign of the actual plumbing, but also required a completely new design of existing crystals and ATR tubes.

Accordingly, a coordinated effort, set up between the engineering staff of Airtron and those of the crystal and tube manufacturers, resulted in the development of new crystals with reverse polarization mountings . . . and new higher power ATR tubes that were inherently pressurizable and demonstrated low VSWR's at high level operation.

As a result, by taking optimum advantage of these new components, Airtron now offers radar designers and manufacturers radically improved duplexers and balanced mixers that are only one-third the previous size . . . yet capable of handling eight times more power . . . with a band width three times greater.

This is just another concrete example of how Airtron's creative engineering . . . and their close association with leading manufacturers in all phases of electronics . . . can be of assistance to you . . . *whether the components you need are new in design or so-called "standard" plumbing.*



New reverse polarized crystal and ATR tube currently used in many radar systems . . . and manufactured according to original design suggestions of Airtron engineers.

Free "Microwave Nomograms and Charts", new 20-page handbook of waveguide engineering data. Write Dept. 1 for your copy today.



Airtron inc. Linden, New Jersey
 Manufacturers of a complete line of rigid and flexible waveguide components
 Branch Offices: Albuquerque • Chicago • Dallas • Dayton •
 Kansas City • Los Angeles • San Francisco • Seattle

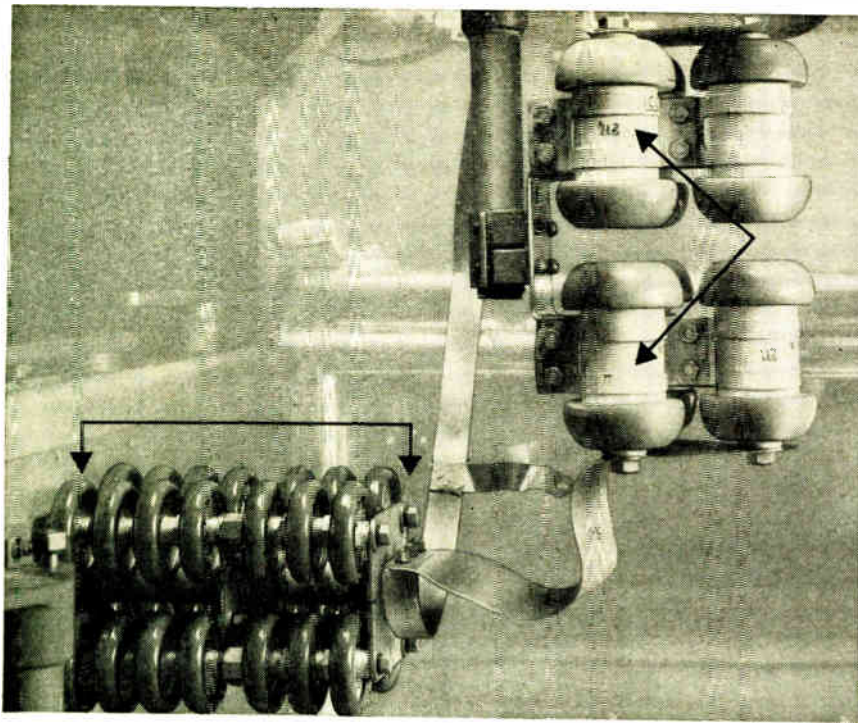

The "NEW LOOK" in ELECTRONIC EQUIPMENT

AEROVOX H-P CERAMIC Power and Transmitting CAPACITORS



Radically different, H-P ceramic-dielectric capacitors serve heavy-duty functions heretofore limited to mica types. Now manufactured and distributed by Aerovox under license, being based on ceramic developments by French engineers and scientists of the C.S.F. organization. H-P capacitors are particularly suitable for broadcasting, radio communications, industrial high-frequency equipment and medical appliances. Tens of thousands such units are serving daily in Europe and even under the climatic extremes of Indo-China.

In both disc ("double-saucer") and cylindrical ("tubular") ceramic dielectric bodies, H-P units are great space- and weight-savers (from 50% to 90% reduction over corresponding micas). Competitively priced. Provide complete independence from imported mica or other strategic materials.

Other outstanding features: Ease of mounting; ease of wiring in series or parallel; very low inductance connections; exceptional immunity to humidity, heat, cold, atmospheric pressure; wide range of designs, sizes, capacitances, voltages. Radically different!

Get the FACTS!

Detailed technical data on request. Let our engineer-specialists collaborate in adapting H-P capacitors to your equipment for that "New Look."



AEROVOX CORPORATION

NEW BEDFORD, MASS.

**Hi-Q
DIVISION**
OLEAN, N. Y.

**ACME
ELECTRONICS, INC.**
MONROVIA, CALIF.

**CINEMA
ENGINEERING CO.**
BURBANK, CALIF.

In Canada: AEROVOX CANADA LTD., Hamilton, Ont.

JOBBER ADDRESS: 740 Belleville Ave., New Bedford, Mass.

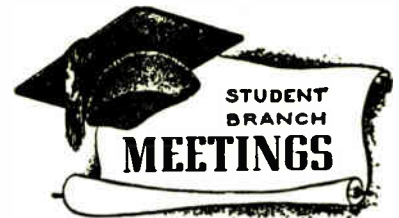

(Continued from page 112A)

UNIVERSITY OF VERMONT, IRE-AIEE BRANCH
"Nuclear Reactors," by John Landis, Babcock and Wilcox; February 25, 1954.

VIRGINIA POLYTECHNIC INSTITUTE,
IRE-AIEE BRANCH

"Electronic Computers in the Field of Guided Missiles," by Prof. E. Q. Smith, Faculty, Virginia Polytechnic Institute; March 9, 1954.

WASHINGTON UNIVERSITY, IRE-AIEE BRANCH

Film: "Bob White Through the Years"; February 25, 1954.

General meeting; March 5, 1954.

"Magnetic Amplifiers," by C. W. Lufcy, Naval Ordnance Labs.; March 11, 1954.

WAYNE UNIVERSITY, IRE-AIEE BRANCH

"Wayne University's Large Digital Computer," by Dr. E. P. Little, Wayne University; February 16, 1954.

UNIVERSITY OF WISCONSIN, IRE-AIEE BRANCH

"Transistors"—demonstration with apparatus by Mr. Burke, Bell Telephone Company; March 10, 1954.

UNIVERSITY OF WYOMING, IRE-AIEE BRANCH

General meeting; March 8, 1954.



The following transfers and admissions were approved to be effective as of April 1, 1954:

Transfer to Senior Member

- Aaron, B. D., 3157 Sepulveda Blvd., Los Angeles 34, Calif.
- Ainlay, A., 987 Wilfred St., Newtonbrook, (Toronto) Ont., Canada
- Armstrong, R. W., Box 95, Neptune, N. J.
- Blackstone, H., 2020 Jericho Tnpk., New Hyde Park, L. I., N. Y.
- Broersma, C. B., 149 DeLairessestraat, Amsterdam Z., Netherlands
- Bullock, M. W., 6805 Northwood Rd., Dallas 25, Tex.
- Cappels, J. L., J. L. Cappels and Associates, 1214 W. Madison, Chicago 7, Ill.
- Carlstrom, T. H., Sylvania Electric Products, Inc., Emporium, Pa.
- Cheatham, T. P., Jr., Hosmer St., Marlborough, Mass.
- Danner, R. V., 2512 Parkview Dr., Baltimore 7, Md.
- Faran, J. J., Jr., 195 Marsh St., Belmont 78, Mass.
- Flyer, I. N., 1419 Kanawha S., Hyattsville, Md.
- Gayer, J. H., I.F.R.B. Palais Wilson, Geneva, Switzerland
- Gershon, J. J., 2533 N. Ashland Ave., Chicago 14, Ill.
- Goodstein, L. P., 98 Thayer St., New York 34, N. Y.
- Grebe, J. J., The Dow Chemical Co., Midland, Mich.
- Gregory, C. A., 132 N. Wayne St., Arlington 1, Va.
- Harrison, A. E., 5318 N. Zadell Ave., Temple City, Calif.

(Continued on page 114A)

YOU TOO CAN HAVE THESE!

We're the source of these imported television lenses which greatly increase camera versatility. Complete the range of your TV camera lenses with these previously unavailable focal lengths. Supplement the lenses you are now using for increased versatility and performance.



ANGENIEUX RETROFOCUS

wide angle lens (35mm focal length) f2.5. Focusing mount with iris diaphragm. Highest resolution for sharpest images.

MEYER PRIMOPLAN

(75 mm focal length) f1.9. Focusing mount with iris diaphragm. Longer than normal focal length for universal application.



MEYER TELEPHOTO

(250 mm focal length) f5.5. In focusing mount with iris diaphragm and built-in lens shade. The light weight construction permits a balanced turret action.



All Lenses Fully Guaranteed for Optical Quality and Top Performance

Write today for our complete price list of all of our special lenses for television cameras—28mm through 250mm. Samples for test purposes available on request.

PONDER & BEST

TELELENS DIVISION
Importers of Fine Photographic Equipment

814 North Cole Avenue
Hollywood 38, California

NEW Berkeley 1 MEGACYCLE - 1 MICROSECOND

Universal Counter & Timer

Four extended-range precision instruments at the size and price of one! Drives digital printer, IBM card punch converter, or digital-to-analog converter!



Berkeley's new Model 5510 Universal Counter and Timer provides the functions of counter, time interval meter, events-per-unit-time meter and frequency meter in one compact instrument. It will:

- ① Count at speeds to 1,000,000 counts per second.
- ② Count events occurring during a selectable, precise time interval.
- ③ Measure time intervals in increments of 1 microsecond over a range of 3 microseconds to 1,000,000 seconds.
- ④ Determine frequencies and frequency ratios, from 0 cps to 1 megacycle.
- ⑤ Provide a secondary frequency standard (stability, 1 part in 10^6).
- ⑥ Operate directly into (a) the new Berkeley Model 1452 single-unit printer, (b) Berkeley digital-to-analog converter, or (c) Berkeley data processor driving IBM card punches, electric typewriters, or teletype systems.

CONDENSED SPECIFICATIONS

Input Sensitivity: 0.2 v. rms (Freq. meas.); 1.0 v. peak to peak (other functions)
 Input Impedance: 10 megohms shunted by 35 mmf.
 Time Bases: 1 mc; 100, 10, and 1 kc; 100, 10 and 1 cps.
 Gate Times: .00001, .0001, .001, .01, 0.1, 1.0 and 10 seconds
 Crystal Stability: 1 part in 10^6 (temp. controlled)
 Display Time: 0.2 to 5 seconds
 Accuracy: ± 1 count, \pm crystal stability
 Power Requirements: 117 v. ($\pm 10\%$), 50-60 cycles, 400 watts
 Dimensions: 20 $\frac{3}{4}$ " wide x 10 $\frac{1}{2}$ " high x 15" deep; panel, 8 $\frac{3}{4}$ " x 19"
 Price: Model 5510, \$1,100.00 (f.a.b. factory).

Available for prompt delivery. Wire or write for technical bulletin, application data; please address dept. N5.

Berkeley

M32

division

BECKMAN INSTRUMENTS INC.
2200 WRIGHT AVE., RICHMOND, CALIF.

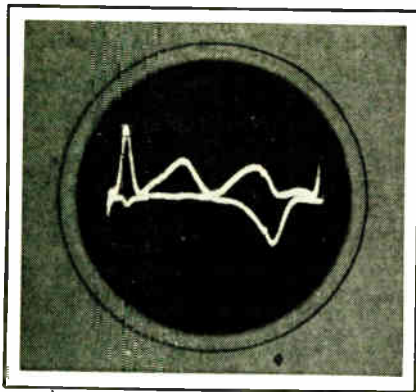

MICROWAVE DEVELOPMENTS

Wheeler Laboratories is an engineering organization offering consulting and engineering services in the fields of radio and radar.

One test equipment developed by the Laboratories contains an oscillator sweeping over the 12% X-band at a rate of 12 round trips per second. As pictured above, an alternating pair of traces simultaneously display two characteristics of a network—in this case, the reflection coefficient and the differential phase angle in transmission; these are utilized while adjusting a multiple-tuned filter in a waveguide.

At present, Wheeler Laboratories includes a staff of twenty engineers under the personal direction of Harold A. Wheeler, a group of designers, and a model shop. Regular additions to the staff are continuing in order to keep pace with our expanding program of work.

Inquiries are welcomed regarding specialized problems in microwave design; a brief summary of our work is available on request.

Wheeler Laboratories, Inc.

122 Cutter Mill Road, Great Neck, N.Y.

HUnter 2-7876



(Continued from page 112A)

- Jacobs, G., 144-40—72 Ave., Flushing 67, L. I. N. Y.
 Jones, W. B., Jr., Electrical Engineering Department, Georgia Institute of Technology Atlanta, Ga.
 Kennedy, C. J., 301 W. Park Ave., Haddonfield, N. J.
 Kirshner, D. R., 116 Rose La., Rome, N. Y.
 Kuck, R. G., 183 Newnan St., Metuchen, N. J.
 Lance, H. W., 6845 Glacier Dr., Riverside, Calif.
 Malsch, J. R., Fa. Telefunken, Soefflinger Strasse, Ulm (Donau), Germany
 McGinnis, F., 4 Bruce La., Eastchester, N. Y.
 Mingst, H. C., 3530 Mifflin Ave., Richmond 10, Calif.
 Munster, A. C., 175 Earl La., Hatboro, Pa.
 Namaroff, J. H., 5517 Beaumont St., Philadelphia 43, Pa.
 O'Bryan, H. M., Sylvania Electric Products, Inc., Bayside 60, L. I., N. Y.
 Patterson, G. W., 312 Dartmouth Ave., Swarthmore, Pa.
 Roush, G. E., Box 142B, R.F.D. 1, Cranbury, N. J.
 Walsh, L., Box 491, Elizabeth 2, N. J.
 Weihe, W. K., 1120-B Lewis Hgts., Apt. 4, Fort Belvoir, Va.
 Williams, F. H., Wheeler Laboratories, Inc., 122 Cutter Mill Rd., Great Neck, L. I., N. Y.
 Zierdt, C. H., Jr., 554 Nottingham Rd., Syracuse 10, N. Y.

Admission to Senior Member

- Arn, S. F., 3315 Moore St., Venice, Calif.
 Baranoff, A. J., 7233 W. 93 Pl., Los Angeles 45, Calif.
 Botwin, L., 585 Saratoga Ave., Brooklyn 12, N. Y.
 Clark, J. L., Melpar, Inc., 452 Swann Ave., Alexandria, Va.
 Colocousis, J., Philco Corp. G & I Division, 4700 Wissahickon Ave., Philadelphia 44, Pa.
 Eberly, H. L., RCA, 415 S. Fifth St., Harrison, N. J.
 Evans, T. P., American Machine and Foundry Co., General Engineering Laboratory, 11 Bruce Pl., Greenwich, Conn.
 Frische, C. A., Sperry Gyroscope Co., Great Neck L. I., N. Y.
 Geer, W., 4519 Pepperwood Ave., Long Beach, Calif.
 Hardin, L. L., Jr., 187 Stelle Ave. Plainfield, N. J.
 Johnson, G. L., Acorn Hill Farm, Lyme, N. H.
 Kay, L. M., 845 Riverside Dr., New York 32, N. Y.
 Kenyon, D. E., 12 Monfort Dr., Huntington, L. I., N. Y.
 Kiser, J. L., VARI-L Co., Inc., Box 1433, Stamford, Conn.
 Kuchinsky, S., 503 City Line Ave., Phoenixville, Pa.
 Learish, H. B., Box 98A, R.F.D. 1, Union, Ohio
 Nieset, R. T., Biophysics Laboratory, Tulane University, New Orleans 18, La.
 Reese, R. F., 909—21 St., Apt. 4, Santa Monica, Calif.
 Robbins, R. W., 1341 South St., Geneva, Ill.
 Rogers, W. E., Electrical Engineering Department, University of Washington, Seattle 5, Wash.
 Sachs, R., 287 Pine St., Lowell, Mass.
 Schramm, C. W., Bell Telephone Laboratories, Inc., Murray Hill, N. J.
 Schweers, O. H., 5 Colony Cir., Camillus, N. Y.
 Shekels, H. D., 4556 Pennlyn Ave., Dayton, Ohio
 Shepard, D. H., Intelligent Machines Research Corp., 134 S. Wayne St., Arlington, Va.
 Underhill, E. M., 274 Phelps Rd., Ridgewood, N. J.
 Vadasz, A. J., Fayette Manor, Fayetteville, N. Y.
 Yarbrough, S. L., Philco Corp., "C" and Tioga Sts. Philadelphia 34, Pa.

(Continued on page 119A)

For improved performance
in high vacuum systems

"WESGO"

ALUMINA INSULATORS

- ultra high purity
- made to any design requirements

For details on properties, write for illustrated brochure.

WESTERN GOLD & PLATINUM WORKS
589 BRYANT STREET, SAN FRANCISCO 7, CALIFORNIA

AT LAST A TRULY FLEXIBLE AIR DIELECTRIC CABLE

ANDREW

HELIAX



Andrew
CORPORATION

363 EAST 75TH STREET, CHICAGO 19
ANTENNA SPECIALISTS

an important "for the first time" story...

There has long been cable easy to install.

There has long been highly efficient cable.

HELIAX is the first cable to deliver both characteristics. It is as flexible in application as solid dielectric cable, but has the same efficiency as copper air dielectric. HELIAX is superior in design, in efficiency and in electrical performance at microwave and all lower frequencies, yet it is comparable in cost to lower frequency cables.

Ease of installation (HELIAX can be pulled through conduit and bent repeatedly without changing its characteristics) means substantial savings in installation costs.

HELIAX is crush proof, may be removed from one installation, coiled and reinstalled. Now available in 7/8" size in continuous lengths. Soon available in larger sizes. Send the coupon for detailed specifications.

ANDREW CORPORATION • 363 EAST 75th ST. • CHICAGO 19, ILLINOIS

Gentlemen:

Please send bulletin 70-A, giving technical details and specifications on your 7, 8" diameter flexible HELIAX cable (Type HX-0).

NAME _____

POSITION _____

COMPANY _____

ADDRESS _____

TRANSMISSION LINES FOR AM-FM-TV-MICROWAVE • ANTENNAS • DIRECTIONAL ANTENNA EQUIPMENT • ANTENNA TUNING UNITS • TOWER LIGHTING EQUIPMENT

World Radio History

**when the job
calls for
controlled
quality...**



the call is for *Electra* deposited carbon resistors

Whether it is for hearing aids, guided missiles, or other electronic precision needs—the uniform quality of Electra carbon coat resistors is an important asset. Electra manufactures only one quality and it is the highest that can be humanly and scientifically produced.

Regardless of the carbon coat resistor need—we at Electra believe that only the highest grade resistor is safest, lowest cost to use. That's why Electra specializes in control of quality and exacting uniformity in every production detail.

This means Electra customers actually get more for their money—a more reliable component part for their product—a resistor whose rejection rate is practically nil. If you manufacture a quality product requiring a deposited carbon resistor, then—be sure—specify Electra.

8 SIZES: 1/8 watt to 2 watts and in two types—coated as well as hermetically sealed. **MANUFACTURED TO SPECIFICATION MIL-R-10509A.**



Write for complete specifications

Electra Manufacturing Co.
2537 Madison Avenue
KANSAS CITY 8, MISSOURI

News—New Products

These manufacturers have invited PROCEEDINGS readers to write for literature and further technical information. Please mention your I.R.E. affiliation.

(Continued from page 78A)

position record equalizer that provides flat playback or equalization for the NARTB or AES recording curves. Speaker output impedances are 8 and 16 ohms.

Price is \$79.50 net f.o.b. Chicago.

Phase & Vector Voltage Meter

Type 213, developed by Advance Electronic Co., P.O. Box 394, Passaic, N. J., is used to measure antenna systems, filters, amplifiers, and other high frequency transmission networks.



The frequency range of this instrument is 10 kc to 300 mc with jack-input probe and 100 kc to 1000 mc with coaxial probe. Both probes are supplied with the instrument. The lower limit may be extended to 1 kc with two additional coupling capacitors. The upper limit may be extended with relaxing accuracy. The input impedance is 2.5 μ f shunted with 100,000 ohms with jack-input probe. The coaxial input probe is normally designed for 50 ohms characteristic impedance. Differential values of characteristic impedance may be obtained upon request. The voltage range is 0.6, 60, and 6 volts full scale. The sensitivity can be lowered to 0.3 volt full scale through a simple adjustment. The phase angle range is 0-180 and 180-360° full scale. Ranges with better angular sensitivity may be arranged. The accuracy is ± 5 per cent nominal. The price is \$228.00, F.O.B., Passaic.

Transistor Analyzer

Polyphase Instrument Co., Bryn Mawr, Pa., announces its Model TA-2 Transistor Analyzer, a negative resistance and characteristic curve tracer which has been designed for use with a laboratory type oscilloscope. It will trace all negative resistance curves of both N-type and P-type point contact transistors.

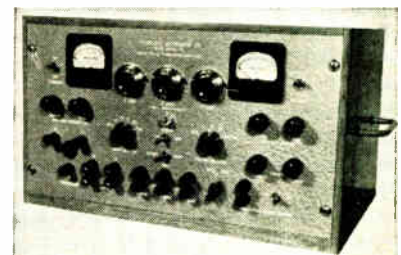

(Continued on page 118A)

How to whip your relay problems!

Just call **ADVANCE...**
we're ready and
willing to make the
relays you need.



CONTACTS, for example

Say the word and we'll up the sizes... switch from fine silver to tungsten, palladium, silver-cadmium oxide, gold contacts, or... you name it!

INSULATION

Laminated phenolic, silicone glass, ceramic steatite, linen-base bakelite, or... you name it!

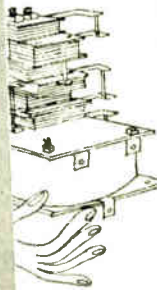
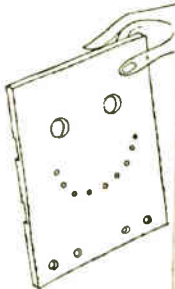

ANYTHING SPECIAL...

ADVANCE will engineer, develop and produce the custom relays you need in minimum time. Call **ADVANCE** for action.

For ELECTRONIC USES

We build a vast variety of sensitive, reliable relays... create superior new designs quickly. You'll find our quality control is now the tightest in the industry.

Write—and let us solve your relay problems



**ADVANCE ELECTRIC
AND RELAY CO.**

2435-G NORTH NAOMI STREET
BURBANK, CALIFORNIA



Another First for

CHICAGO

The complete **MS** (Military Standard) line of Hermetically-Sealed Power & Filament Transformers

CHICAGO TRANSFORMER now offers all units in the Military Standard (MS) line, as established jointly by the three armed forces (Army Signal Corps, Navy Bureau of Ships, and Air Force) working through ASEA (Armed Services Electronic Standards Agency) and in cooperation with the transformer industry. The complete line is housed in CHICAGO's one-piece drawn-steel cases. Outside case dimensions and mounting dimensions are within the tolerances of the Military Standard specification. Terminal arrangements and markings are also in accordance with the same specification. Tests conducted in the CHICAGO TRANSFORMER laboratories indicate that all units will meet the requirements of Grade 1, MIL-T-27 specifications for Class A operation. The Military Standard line should find wide usage in military airborne, marine, and ground communication equipment, and particularly for research and development applications, pilot runs and pre-production models.

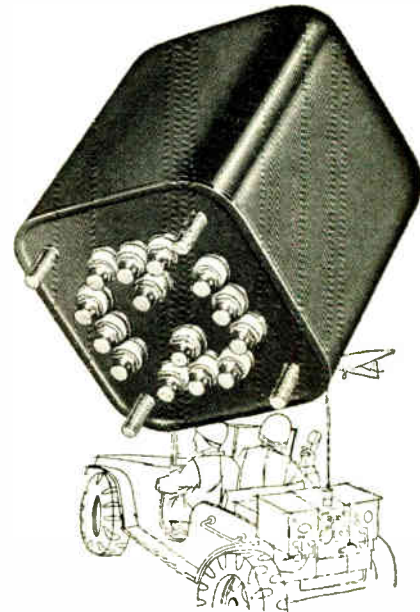

POWER TRANSFORMERS—INPUT REACTOR SYSTEMS (PRIMARY—105/115/125 V.—Frequency 54-66 cycles)

CATALOG NUMBER	MIL-T-27 PART NO.	HIGH VOLTAGE A-C Volts	SECONDARY D-C MA.	D-C V OUTPUT	RECT. FIL. Volts Amps.	FIL. NO. 2 Volts Amps.	WT. LBS.
PMS-70	MS-90026	200-100-0-100-200	70	385	6.3/5	2 6.3 3	4
PMS-70A	MS-90027	325-0-325	70	260	6.3/5	2 6.3 4	5
PMS-150	MS-90028	325-0-325	150	245	6.3	5 5 3	7 1/4
PMS-175	MS-90029	400-0-400	175	318	5	3 6.3 8	10
PMS-250	MS-90030	450-0-450	250	345	5	3 6.3 8	13
PMS-350	MS-90031	350-0-350	250	255			7 1/2
PMS-550	MS-90032	550-0-550	250	419			11
PMS-800	MS-90036	800-0-800	250	640			16 1/2

FILAMENT TRANSFORMERS (PRIMARY—105/115/125 V.—Frequency 54-66 cycles)

CATALOG NUMBER	MIL-T-27 PART NO.	SECONDARY Volts Amps	INSULATION VOLTS RMS	WT. LBS.
FMS-23	MS-90016	2.5 3.0	2500	1 1/2
FMS-210	MS-90017	2.5 10	2500	2 1/2
FMS-53	MS-90018	5.0 3.0	2500	1 3/4
FMS-510	MS-90019	5.0 10	2500	4
FMS-62	MS-90020	6.3 2.0	2500	1 3/4
FMS-65	MS-90021	6.3 5.0	2500	2 3/4
FMS-610	MS-90022	6.3 CT 10	2500	5
FMS-620	MS-90023	6.3 20	2500	8
FMS-210H	MS-90024	2.5 10	10000	4 3/4
FMS-510H	MS-90025	5.0 10	10000	7

Free "New Equipment" Catalog

You'll also want the full details on CHICAGO'S New Equipment Line of famous "Sealed-in-Steel" Transformers. Write for Free Catalog CT-153 today, or get it from your electronic parts distributor.

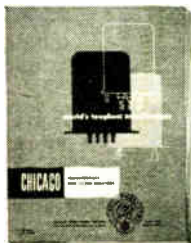

CHICAGO STANDARD TRANSFORMER CORP.

3501 W. ADDISON ST., CHICAGO 18, ILL.

STANDARD SIGNAL GENERATOR

2 Mc. - 400 Mc.

Model 80

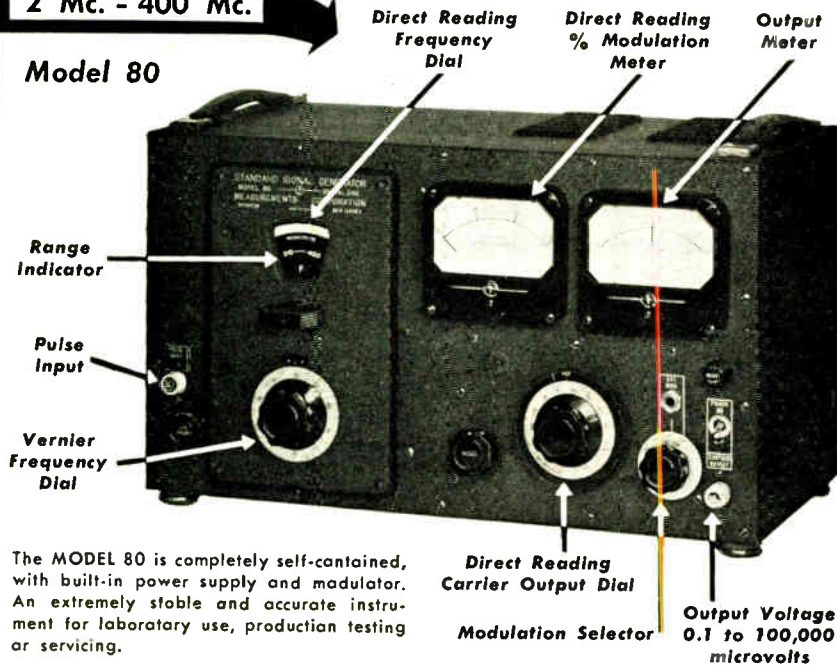

The MODEL 80 is completely self-contained, with built-in power supply and modulator. An extremely stable and accurate instrument for laboratory use, production testing or servicing.

Complete data on request

MEASUREMENTS CORPORATION
BOONTON NEW JERSEY

AN/APR-4 LABORATORY RECEIVERS



Complete with all five Tuning Units, covering the range 38 to 4,000 Mc.; wideband discone and other antennas, wavetraps, mobile accessories, 100 page technical manual, etc. Versatile, accurate, compact—the aristocrat of lab receivers in this range. Write for data sheet and quotations.

We have a large variety of other hard-to-get equipment, including microwave, aircraft, communications, radar; and laboratory electronics of all kinds. Quality standards maintained. Get our quotations!

NEW TS-13/AP X-BAND SIGNAL GENERATORS, with manual, \$850.00 . . . TS-175/U Frequency Meters, 85-1,000 Mc., \$625.00 . . . T-47A/ART-13 Transmitters, \$450.00 . . . and many more!

ENGINEERING ASSOCIATES

434 PATTERSON ROAD

DAYTON 9, OHIO

Cosmic

**ELECTROLYTIC
and
PAPER TUBULAR
CONDENSERS**

FOR
**A.C. D.C. SETS
PHONOGRAPHS**
etc.

CONDENSER SPECIALISTS SINCE 1923

COSMIC RADIO CORPORATION
853 Whittier St., Bronx, N. Y.
Phone LUdlow 9-3360

News—New Products

These manufacturers have invited PROCEEDINGS readers to write for literature and further technical information. Please mention your I.R.E. affiliation.

(Continued from page 116A)

Since all circuit parameters controlling the negative resistance curves are available as metered variables on the front panel, the Model TA-2 enables the user to visually design any negative resistance circuit around a given transistor in a matter of minutes. The TA-2 will also determine the applicability of any transistor in a given negative resistance circuit.

In addition, the TA-2 will trace the collector characteristics, R_{22} , for both grounded emitter and grounded base connections, and transfer characteristic, R_{12} , of N-type and P-type point contact transistors and NPN and PNP junction transistors.

Transistor-Magnetic Microphone

By using transistors to make a diminutive pre-amplifier coupled with a high quality magnetic microphone, Remler Company Ltd., 2101 Bryant St., San Francisco 10, Calif., has developed a new combination unit yielding improved speech intelligibility and reduced noise in radio and aircraft applications.



The transistors are built into the microphone unit in both straight microphone and handset applications. Units plug directly into existing equipment previously using carbon button microphones.

The amplifier, plastic seal-coated by a Remler-developed process, has been subjected to thousands of hours of life tests, humidity, hot and cold, and high altitude tests. It has also been flight-tested by a major airline. The microphone itself is the Remler ruggedized unit formerly supplied to the U. S. Navy and merchant marine service. Low noise and high intelligibility are attained without increasing the complexity and weight of the radio transmitter or announcing equipment. This new microphone is now in production at the San Francisco plant.

Variable Air Capacitors

Johanson Manufacturing Corp., Boonton, N. J., announces a new line of variable air capacitors. Small in size and of

(Continued on page 120A)



(Continued from page 114A)

Transfer to Member

- Appel, H. G., Sr., Sylvania Electric Products, Inc., 83-30 Kew Gardens Rd., Kew Gardens 12, L. I., N. Y.
- Birx, D. L., The Franklin Institute Laboratories, Philadelphia 3, Pa.
- Bisso, R. J., 99 Meadow Rd., Emporium, Pa.
- Bletcher, A. L., 4433 Silsby Rd., Cleveland 18, Ohio
- Bogner, R. D., 67 Cheshire Rd., Bethpage, L. I., N. Y.
- Boisvert, M., 1340 DuBuisson, Sillery, Que., Canada
- Boxx, J. P., 2112 Westview Dr., Owensboro, Ky.
- Brawner, C. A., Jr., 7207 Fisher Rd., R.F.D. 4, Dallas 14, Tex.
- Brown, M. A., 308 Second Ave., Bradley Beach, N. J.
- Buie, J. L., 11156 Valerio St., Sun Valley, Calif.
- Cartwright, J. R., 52, Lytton Ave., Letchworth, Herts., England
- Cerino, C., 53-10 Overbrook St., Little Neck 63, L. I., N. Y.
- Couzens, D. T., S Tel O, RCAF AMCHQ, No. 8 Temporary Bldg., Ottawa, Ont., Canada
- Davidson, R., Dynamic Electronics-New York, Inc., 73-39 Woodhaven Blvd., Forest Hills, L. I., N. Y.
- Doe, U. P., Chief Engineer, Dept. of Broadcasting, 28 Windermere Crescent, Rangoon, Burma
- Flynn, M. W., 24 Fairbank Ave., Toronto 10, Ont., Canada
- Gilbert, E. M., 7512 Buena Vista Del Val, Burbank, Calif.
- Gunderson, A. L., 3959 Highland Dr., Salt Lake City 7, Utah
- Hansen, E., 2945 Alton Ave., Allentown, Pa.
- Hinds, J. E., Jr., 6 Brompton Rd., Garden City, L. I., N. Y.
- Hix, E. W., 729 Noah, Akron, Ohio
- Jahoda, J. R., 4321-69 St., Woodside 77, L. I., N. Y.
- Khoury, N., 804 Brunswick Rd., Baltimore 21, Md.
- Koppel, A. V., 60-01D-194 St., Fresh Meadows 65, L. I., N. Y.
- Kunik, I. J., 521 Fifth Ave., New York 17, N. Y.
- LaPointe, J. C., 5208-42 Pl., Hyattsville, Md.
- Leadabrand, R. L., Radio Propagation Laboratory, Stanford University, Stanford, Calif.
- Leskinen, J. I., 33-45-172 St., Flushing 58, L. I., N. Y.
- MacDonald, C. F., 182 Duchess Ave., London, Ont., Canada
- Magestro, J. C., 1783 Wacker Dr., Lancaster, Ohio
- McDonough, V. T., 31-40-30 St., Apt. C4, Astoria, L. I., N. Y.
- McKnight, C. J., c/o The American Legation, Tangier, Morocco
- Murray, H. J., Jr., 703-37 Ave., Oakland 1, Calif.
- Nail, P. L., 3028 E. 53 St., N. Kansas City 16, Mo.
- Paulos, P. J., 11250 Playa St., Culver City, Calif.
- Petersen, M. C., Box 605, Fair Oaks, Calif.
- Reinish, G. B., 2709 Ocean Ave., Brooklyn 29, N. Y.
- Rothauge, C. H., U. S. Naval Postgraduate School, Monterey, Calif.
- Ruehl, G. C., Jr., 31 E. 21 St., Baltimore 18, Md.
- Saxon, W. R., 1931 W. Vermont Ave., Phoenix, Ariz.
- Smith, L. E., 12066 Milton St., Silver Spring, Md.
- Spencer, N. A., 1 Terrace Cir., Great Neck, L. I., N. Y.
- Velasco, F. C., 7835 S. Harvard, Los Angeles, Calif.
- Winick, A. B., 1415 Oakridge Rd., Falls Church, Va.

Admission to Member

- Aasgaard, P. U., 1360 Ouimet St., Apt., 41, Ville St. Laurent, Que., Canada

(Continued on page 122A)

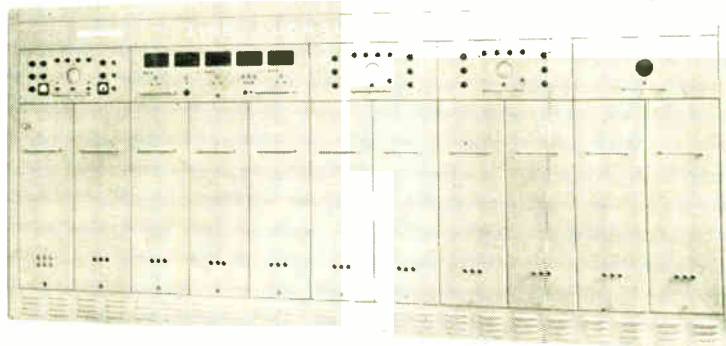

This compact equipment is accessible, too, because of this

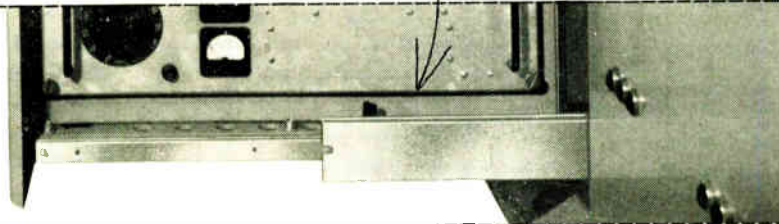
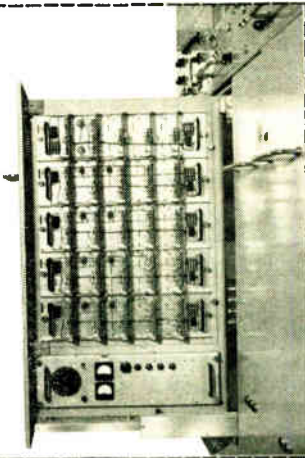

This Time Signal Generator was built for Air Force ballistics testing by Vitro Laboratories, a division of Vitro Corporation of America. It employs Grant Industrial Slides.

We asked Charles K. Raynsford, project group leader, why Grant Slides were used here. His answer:

"Primarily for the convenience of the service technician. Each of those eleven sections contains approximately 150 vacuum tubes. Even with the low tube failure rate of 2% per 1000 hours, fast serving for preventive maintenance becomes quite important!

"In addition, this compactness would have been impossible without the Slides. In a conventional arrangement, the unit would have been twice as large."

"May we quote you on that?" we asked.

"Well," he answered, "say 'appreciably larger'. That would have increased the wiring capacitance, which, in turn, would have required more power to get the same band width."

"All in all, we're proud of this design," he added.

That makes it even. We're proud of our Slides.

Grant Industrial Slides

A product of Grant Pulley and Hardware Corporation
31-75 Whitestone Parkway, Flushing, New York

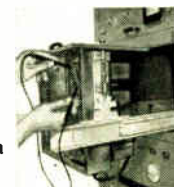

Designed for



Application



**Crystal Holder Sockets
33002, 33102, and 33202
Plus new 33302 for CR7**

In addition to the original 33002, 33102 and 33202 exclusive Millen "Designed for Application" steatite crystal holder sockets, there is now also available the new 33302 for the new CR7 holder. Essential data:

Type	Pin Dia.	Pin Spacing
33002.....	.125	.750
33102.....	.095	.500
33202.....	.125	.500
33302.....	.050	.500

**JAMES MILLEN
MFG. CO., INC.**

MAIN OFFICE AND FACTORY
MALDEN
MASSACHUSETTS



News—New Products

These manufacturers have invited PROCEEDINGS readers to write for literature and further technical information. Please mention your I.R.E. affiliation.

(Continued from page 118A)

instrument quality, the new units feature simplicity of design for all uhf and rf applications. Single to four gang sections are standard units of the new line.

Each of the new capacitors has a frame which is swaged and soldered. Each has a three point mounting. The units are provided with hardened stainless steel ball bearings, and all rotors and stators of the units are soldered to further insure permanency. The wipers are of hardened, silver-plated, beryllium copper. The units are constructed of silver-plated brass (or invar) for low surface resistance.

The compression-loaded ceramic rod stator suspension gives it long dielectric path and mechanical reliability. A variable air trimmer is an integral part of each section in the unit.

For additional information, write Johanson directly.

Circuit Comparison Bridge

New general utility comparison bridge, trade marked "Circuit Matcher," improves efficiency in production testing of equipments, is available from McShan Development Corp., 71 Murray St., New York 7, N. Y. Comparison of unknown circuits is made against those of a prototype of known performance.



The instrument is equipped with two 9-conductor shielded cables terminated in noval plugs and mating adapters for other socket types. A pushbutton selector provides rapid comparison of similar circuits by ac or dc bridge tests. A point-to-point ohmmeter with flexible selector means is provided as a servicing aid. Two pair of panel terminals are provided for component comparison. A single balance control indicates circuit deviation from 75 to 30 per cent of normal impedance with 1 per cent accuracy over a wide range. Control simplicity enables non-skilled operation.

(Continued on page 128A)

**Potter &
Brumfield's
MB3D miniature DC
power contactor**

for very
high current
applications

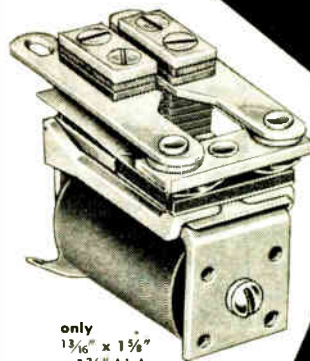

only
1 3/16" x 1 3/8"
x 1 3/4" high

- 1 Massive, solid silver shorting bar works against 1/4" dia. pure silver contacts.
- 2 Standard contact rating 60 amperes 28 volt DC non-inductive load.
- 3 Heavy brass contact arms with large, tinned solder terminals.
- 4 Over-travel spring of nickel silver spring temper for maximum contact pressure, long life.
- 5 Magnetic structure utilizes high permeability relay steel.

● Ideal for dynamotor starting applications in mobile, aircraft or marine equipment, and for other high current applications where space and weight are at a premium. Samples, recommendations and quotations on request.

ALSO
AVAILABLE
HERMETICALLY
SEALED



**POTTER &
BRUMFIELD**

PRINCETON, INDIANA

Engineering Offices
in Principal Cities
Export—
13 East 49th St., New York, N. Y.



SOMEWHERE IN
OUR COAT
OF ARMS WE
SHOULD HAVE
A CATS WHISKER



**-TO
SYMBOLIZE
ACCURACY**

If there's one thing for which we want to be famous (and maybe we *are*), it's precision.

A lot of folks can lick us on making, say, kitchen appliances, because we specialize on jobs calling for quality and accuracy.

This kind of quality makes money for you in the long run by keeping: (1) your production lines running smoothly; (2) your maintenance and repair inventory and costs down, and (3) your own sales up. We call it "profitable precision."

**CONRAD
& MOSER**

**Workers in Aluminum,
Brass, Steel & Plastics**

DESIGNING
ENGINEERING • MANUFACTURING
MECHANISMS • MACHINES
PARTS • TOOLS • DIES • MOLDS
STAMPINGS • CASTINGS
MACHINING • SHEET METAL
ENCLOSURES & CHASSIS
1/8 to 1/2 NAVY SPEC ALUMINUM
SPOT WELDING AND HELIARC
WELDING.

**2 Borden Ave.
Long Island City 1, N.Y.**

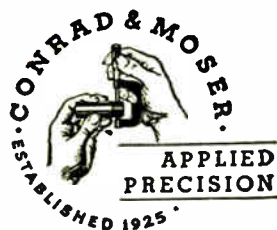

**At last!
Printed Circuit
Tube Sockets that**

**-withstand punishing
shock and vibration**

**made of
MYCALEX® 410
glass-bonded mica**

- LOSS FACTOR .014 at 1 mc/s
- POWER FACTOR .0015 at 1 mc/s
- HIGH DIELECTRIC STRENGTH
- NO CARBONIZATION
- ZERO COLD FLOW
- IMMUNE TO FUNGUS

MYCALEX printed circuit tube sockets effectively eliminate broken or loose connections that ordinarily result from tube insertion and removal, shock and vibration. An exclusive MYCALEX contact design permits a positive mechanical attachment in conjunction with a soldered connection. The mechanical attachment safeguards against stress at all times, insures the permanence of the soldered connection between printed circuit and socket contact. Troublesome intermittent contacts, costly repairs are thus eliminated.

Application of these sockets to your printed circuit can speed production, reduce rejects, improve performance. For information call or write J. H. DuBois, Vice President-Engineering, at Clifton, N. J., address below.

NOTE: MYCALEX 410 glass-bonded mica is an exclusive formulation of and manufactured only by the Mycalex Corporation of America. It meets all the requirements for Grade L-4B under Joint Army-Navy Specifications JAN-1-10.



MYCALEX TUBE SOCKET CORPORATION

Under exclusive license of Mycalex Corporation of America,
World's largest manufacturer of glass-bonded mica products

ADDRESS INQUIRIES TO—

General Offices and Plant: **111** Clifton Blvd., Clifton, N. J.

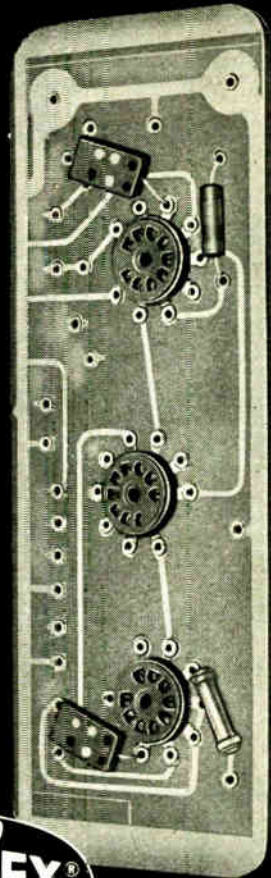

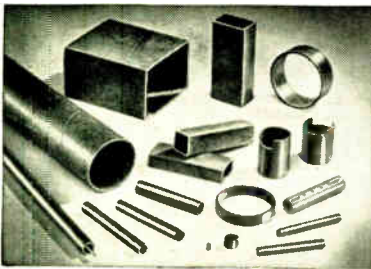

RESINITE

GIVES YOU THE HIGHEST INSULATION RESISTANCE OF ANY RESINATED PRODUCT

Performance data—compiled from laboratory tests, actual field operations and reports from manufacturers—prove the outstanding operating characteristics of Resinite. In volume resistivity... low moisture absorption... excellent thermal properties... low power factor... and resistance to voltage breakdown... Resinite outperforms all other resinated products.

Resinite Coil Forms are available with inside or outside threads—slotted, punched or embossed. Special three-row threaded design permits axial pressure in excess of 25 lbs. Torque controllable to + or -1 inch oz.

RESINITE 8104
very high dielectric properties under extreme humidity.

RESINITE "AC"
very high dielectric properties—completely immune to electrolytic corrosion.

RESINITE 104
for stapling, severe forming and fabricating

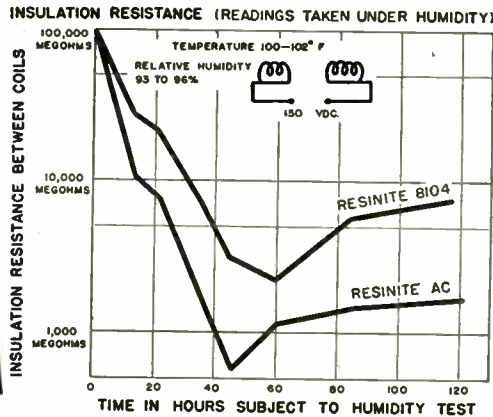

Tests conducted on .253 I.D. x .283 O.D. tubes used on coil forms for television receivers.

Write today for full details and technical information

RESINITE CORPORATION

DIVISION OF PRECISION PAPER TUBE

2035G West Charleston Street, Chicago 47, Illinois
79 Chapel St., Hartford, Conn.

NOISE and FIELD INTENSITY METER Model NF-105 (Commercial Equivalent of AN/URM-7)

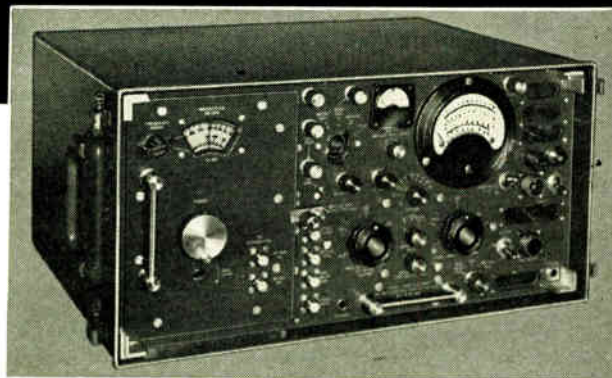

CONFORMS TO
MIL-I-6181B
MIL-I-16910

ENGINEERING DATA

- Frequency range 20 MC to 1000 MC by means of three quick-change tuning heads. At least one RF amplifier with tuned input is employed for each tuning range.
- Easy frequency scanning by means of single tuning knob.
- Built-in impulse noise calibrator flat to 1000 MC (Output externally available).
- 4 1/2" logarithmic indicating meter reads carrier or true peak.
- Aural slideback operation.
- Input VSWR better than 1.2 to 1.
- Built-in regulated "A" and "B" supply.
- Complete line of accessories available.

Write today for additional information and our complete catalog

edp **EMPIRE DEVICES PRODUCTS CORPORATION**
38-15 BELL BOULEVARD • BAYSIDE 61, NEW YORK

MANUFACTURERS OF

FIELD INTENSITY METERS • DISTORTION ANALYZERS • IMPULSE GENERATORS • COAXIAL ATTENUATORS • CRYSTAL MIXERS



(Continued from page 119A)

- Abrams, G. M., 3752 Neptune Ave., Brooklyn 24, N. Y.
Anstett, F. D., 107 Pinetree La., Roslyn Heights, L. I., N. Y.
Ayers, E. D., 182 Cypress St., Midland, Mich.
Bain, J. D., Canadian Arsenals, Ltd., Leaside, Ont., Canada
Bennett, A. F., Countryside, Summit, N. J.
Berman, H. M., 41 Kew Gardens Rd., Kew Gardens 15, L. I., N. Y.
Bittmann, E. E., 75 Patton Ave., Princeton, N. J.
Black, L., Box 588, R.F.D. 1, Annandale, Va.
Blair, J. E., 3034-33 Pl., Sandia Base, Albuquerque, N. Mex.
Bolie, V. W., 501-31 St., S.E., Cedar Rapids, Iowa
Brewer, W. L., 275 Sagamore Dr., Rochester 17, N. Y.
Brower, J. D., 603 Rutland Rd., Brooklyn 3, N. Y.
Brown, D. M., 42 Francesca Ave., West Somerville 44, Mass.
Bruno, T. P., 291 Boulevard, Pompton Plains, N. J.
Craig, A. F., 178 Red Maple Dr., E., Levittown, L. I., N. Y.
Cummins, R. G., 161 E. California St., Pasadena, Calif.
Dombrady, S. E., 7419 Essen Ave., Parma 29, Ohio
Donaldson, W. L., 2036 Walnut St., Allentown, Pa.
Driver, G. E., 88 Sibert St., Richland, Wash.
Dulac, A. A., 55 Neillan St., Bedford, Mass.
Duncan, P. B., 3317-B S. Wakefield, Arlington 6, Va.
Eltgroth, M. J., 567 N. Long Ave., Chicago 44, Ill.
Fisher, M. K., 7600 Earldom Ave., Playa Del Rey, Calif.
Fletcher, M. W., 490 Ontario St., Toronto, Ont., Canada
Gibson, S. K., 108 Greenwood La., Waltham 54, Mass.
Grabowski, S. J., 926 Altamont Ave., Schenectady, N. Y.
Grubman, S., 316 Oakley Ave., West End, Long Branch, N. J.
Gunst, M. A., Jr., 5851 Romany Rd., Oakland 18, Calif.
Haase-Dubosc, A. A., 135 Broadway, New York 6, N. Y.
Hansen, G. K. F., 81 Tornerosevej, Herlev, Denmark
Hardwick, F., 360 Berwick St., Orange, N. J.
Hart, C. O., 803 S.W. 49 St., Oklahoma City 9, Okla.
Hawkins, W. E., James Millar Associates, Box 7116, Station C, Atlanta, Ga.
Hawn, L. R., Jr., 1289 N. Los Robles, Pasadena 6, Calif.
Heller, A., 612 Kensington Pl., N.E., Washington 11, D. C.
Helwig, C. G., Apt. 803, Lakeside Pk., Toronto Ont., Canada
Hermon, R., 646 Hawbrook, Kirkwood 22, Mo.
Hunicke, R. L., Talcott Rd., Williamstown, Mass.
Jury, E. I., 779 Riverside Dr., New York 32, N. Y.
King, K., 1631 Rickenbacker Rd., Baltimore 21, Md.
Kaylin, R. R., 16-02 Everett Ter., Fair Lawn, N. J.
Lavoie, L., La Cie De Tel. de Kamouraska, Riviere-du-Loup, Que., Canada
Lochanko, A. A., 60 Ellis Park Rd., Toronto, Ont., Canada
Long, W. G., Jr., 4801 Fourth Ave., S.E., Washington 21, D. C.
Lowitz, G., 145 Durston Ave., Syracuse, N. Y.
Lynch, D. J., 5115 Walker Way, El Paso, Tex.
Manahan, W. A., 5630 Arbor Vitae, Los Angeles 45, Calif.
McCaffrey, B. I., Avionics, Ltd., Box 84, St. Catharines, Ont., Canada

(Continued on page 124A)

ZOPHAR

---WAXES
---COMPOUNDS

Zophar Waxes, resins and compounds to impregnate, dip, seal, embed, or pot electronic and electrical equipment or components of all types; radio, television, etc. Cold flows from 100°F. to 285°F. Special waxes non-cracking at -76°F. Compounds meeting Government specifications plain or fungus resistant. Let us help you with your engineering problems.



ZOPHAR MILLS, INC.
112-130 26th Street,
Brooklyn 32, N. Y.

A NEW UNIVERSAL KLYSTRON POWER SUPPLY — for MICROWAVE OSCILLATORS



- Operates all low power commercial klystrons.
 - Positive or negative grid operation.
 - Widest modulation frequency range.
 - Beam voltage: Regulated continuously variable over ranges of 300 to 1500 v. at 65 ma. or to 3600 v. at 25 ma.
 - Repeller voltage: Direct reading continuously variable over the range of -20 to -750 volts.
 - Modulation: Square wave, saw tooth, external or highly stable c-w operation.
- Specify the PRD Model 801-A

PolYTECHNIC
RESEARCH & DEVELOPMENT CO., Inc.

55 JOHNSON ST., BROOKLYN 1, NEW YORK
West Coast: 741 N. Seward St., Hollywood 38, Calif.

RESEARCH brings you a compact, light, economical new oven

THE JK09 CRYSTAL OVEN

- Only 1.28" dia.x1.70" high and weighs only 1.5 oz.
- Minimum temperature gradient at crystal.
- Rapid warm up with no overshoot.
- Will meet a specification of $75^{\circ}\pm 1^{\circ}\text{C}$ over a temperature range of -55° to $+70^{\circ}\text{C}$.
- Economical and reliable because design permits tooling for uniform production.



STABILITY

Thru "Thermaflow" Design*

Temperature, like water, seeks its own level. Instead of trying to "dam up" heat within the oven, by use of massive heat retaining elements, the JK09 oven is designed to permit a uniform loss and uniform replacement of heat. Heat is simply replaced as it is lost from the low mass, high conductivity shell. And within this shell the crystal unit remains wrapped in a blanket of warm air. Because sufficient heat is always lost by the shell none need be yielded by the crystal.

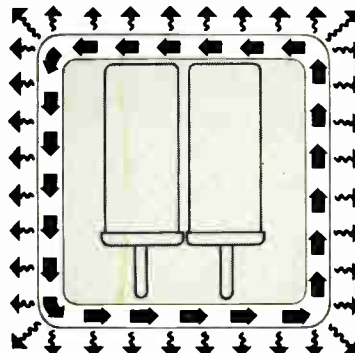

JK09 Heat Exchange Pattern



PRODUCTS

Symbol of Service

THROUGH RESEARCH STABILITY AVAILABILITY

The compact, light, inexpensive JK09 matches the performance of many ovens employing multistage heaters and massive heat-retaining elements. It houses one or two crystals, plugs into an octal tube socket, is available with a choice of heater voltage from 6 to 28 volts. It is another JK step in the advancement of miniaturization and extreme stability. Write us for complete engineering information.

The James Knights Company Sandwich, Ill.

AVAILABILITY

A COMPLETE LINE

The JK09 is the newest of the many frequency control units that comprise the JK line of Crystals for the Critical.

* A James Knights Patent.

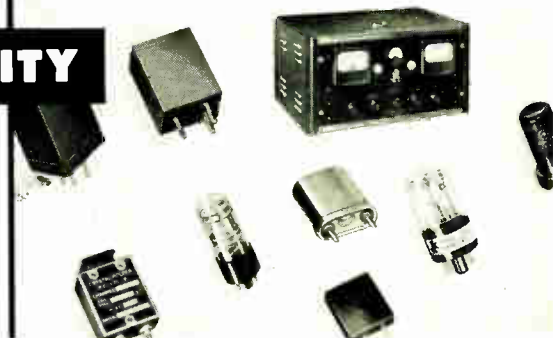

World Radio History

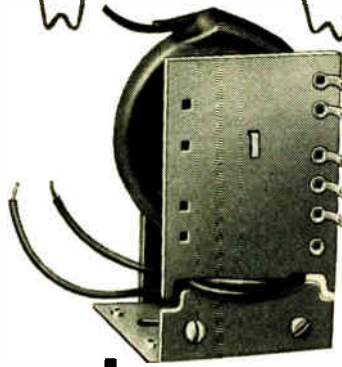
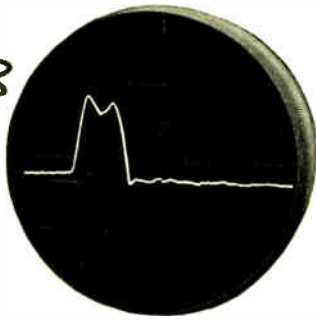

measuring
re-trace time
assures
FLYBACKS designed to your
exact specifications—
built for **EXTRA** years of trouble-free performance.

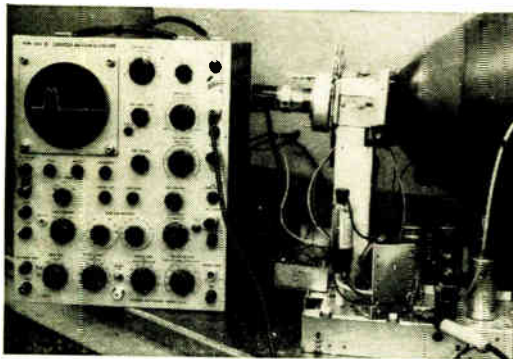

FAST SERVICE

on your requirements: Heppner has



2 airplanes and 6 pilots in the

Sales and Engineering Departments.

SPECIALISTS IN ELECTRO-MAGNETIC DEVICES

HEPPNER
MANUFACTURING COMPANY

Round Lake, Illinois (50 Miles Northwest of Chicago)
Phone: 6-2161

Representatives: **John J. Kopple**
60 E. 42nd St., New York 17, N. Y.

James C. Muggleworth
506 Richey Ave., W. Collingswood, N. J.

Ralph Haffey
R. R. 1, U. S. 27, Coldwater Rd.,
Fl. Wayne 8, Indiana

Irv. M. Cochrane Co.
408 So. Alvarado St., Los Angeles, Calif.



(Continued from page 122A)

- McCormick, D. A., 247 Lincoln Ave., Newark 4, N. J.
McGehee, W. W., 1904 Chaucer Dr., Apt. D, Cincinnati 37, Ohio
Messner, R. W., 3507 Ailsa Ave., Baltimore 14, Md.
Myer, J. H., 5636 Clemson St., Los Angeles 16, Calif.
Moore, W., Jr., 342 Maple Ave., North Hills, Pa.
Neenan, C. J., Cross Highway, Westport, Conn.
Nosal, P., 8 Pasture Ct., Bethpage, L. I., N. Y.
Oliverio, A. P., 1414 N. Hobart Blvd., Los Angeles 27, Calif.
Parkinson, C. B., Jr., 431 N. Encinitas, Monrovia, Calif.
Pfister, G. H., R.F.D. 2, Seneca Falls, N. Y.
Plummer, D. K., 66 W. Park Rd., Grand Island, N. Y.
Ponemon, R. D., Pyroferic Bldg., New York 67, N. Y.
Poucher, R. A., Jr., 3021 Mountain View Ave., Sacramento 21, Calif.
Powell, J. A., Frenchtown Porcelain Co., Frenchtown, N. J.
Ramsay, J. H., 219 Byberry Rd., Hatboro, Pa.
Rapaport, H., 315 E. Fifth St., New York 3, N. Y.
Richart, D. H., 1941 Fry Ave., Williamsport, Pa.
Robertson, H. E., 120 N. Broadway, Irvington, N. Y.
Roman, A. F., Electronic Tube Corp., 1200 E. Mermaid La., Philadelphia 18, Pa.
Rosencrantz, M. E., 4744 Overland Pkwy., Apt. 204, Toledo, Ohio
Samuel, R., 800 Riverside Dr., Apt. 6F, New York 32, N. Y.
Silverman, R. A., 15 Bryn Mawr Rd., Wellesley 81, Mass.
Steele, R. W., 401 Fourth Ave., White Sands Proving Ground, Las Cruces, N. Mex.
Stewart, A. C., 1200 E. Washington Ave., Council Bluffs, Iowa
Stewart, T. A., Federal Electric Mfg. Co., Ltd., 9600 St. Lawrence Blvd., Montreal 14, Que., Canada
Stone, N., 64 Wadsworth Ter., New York 33, N. Y.
Strongin, J., 86 Beekman Ave., Mount Vernon, N. Y.
Swanson, C. R., 3944 N. Greenview Ave., Chicago 13, Ill.
Tomlinson, C. C., 1721 Lansing Rd., Glen Burnie, Md.
Tullius, R. F., 5503 W. Lovers La., Dallas 9, Tex.
Tyndall, R. M., 423 W. Main St., Huntington, N. Y.
White, C. E., 818 N. Harrison St., Arlington 5, Va.
Wild, T. A., York Rd., Timonium, Md.
Williams, R. O., 1515 Boutz, Las Cruces, N. Mex.
Woerner, J. J., Box 185, Kentfield, Calif.
Wylde, W. N., 479 Maple Hill Dr., Apt. 33, Hackensack, N. J.
Yarter, B. P., 819—15 St., Alamogordo, N. Mex.

The following elections to the Associate grade were approved to be effective as of April 1, 1954:

- Abbe, R., 261 2-chome, Tamagawa-Todoroki-Machi, Setagaya-ku, Tokyo, Japan
Acker, A. E., 1244 Morningside Dr., Sunnyvale, Calif.
Acker, R. E., 2017 Parkview Ter., Spring Lake Heights, N. J.
Adamson, H. D., 6013 First Ave., N., Birmingham 6, Ala.
Ahmed, G., Lady Cunningham Maternity and Child Centre, Abbottabad, Pakistan
Akerberg, E. D., 181 Signal Depot Co., San Francisco, Calif.
Allgeyer, G. O., 7818 Flight Ave., Los Angeles 45, Calif.
Althaus, E. J., Hughes Aircraft Co., Florence & Teale Sts., Culver City, Calif.
Amey, G. B., 968 N. Market St., Williamsport, Pa.

(Continued on page 127A)

STILL LEADING THE BIG

Electronics Parade!

E-I

HERMETICALLY-SEALED

miniature closures

—FOR TRANSISTORS AND OTHER COMPONENTS

NO. 1 SERIES NO. 3 SERIES



TRANSISTOR CLOSURES

(SHOWN ACTUAL SIZE)

WRITE FOR THESE CATALOGS

- BULLETIN 949-A On hermetically sealed terminals. Discusses cushioned glass construction, thermal shock resistance, preferred types and special terminals.
- BULLETIN 950-A On hermetically sealed multiple headers. Explains vacuum tight feature, cushioned glass construction, strain-free qualities.
- BULLETIN 951 With complete information on octal type plug-in and multiple headers. Solid metal blanks insure maximum mechanical strength and rigidity.
- BULLETIN 952 Complete information on E-I end seals for hermetic sealing condensers, resistors and other tubular electronic and electrical components.
- BULLETIN 953 Individual, color-coded hermetically sealed terminals. Available with glass inserts colored in standard, easily identified RMA color codes.
- BULLETIN 960 Compression type multiple headers. Super rugged, absolutely rigid and practically indestructible. Guaranteed vacuum-tight.



New EI Miniature Closures can be supplied in various standard types or economically produced to your exact specifications for all electrical and electronic applications. The EI closure types illustrated are typical examples of the many miniature designs now in production. Cases can be supplied in round, rectangular or square shapes with hermetically sealed terminations to your order.

FOR COMPLETE DATA AND PRICES ON SPECIFIC TYPES OF MINIATURE CLOSURES; CALL OR WRITE,

twice actual size

*PATENT PENDING ALL RIGHTS RESERVED



DIVISION OF AMPEREX ELECTRONICS CORPORATION

ELECTRICAL INDUSTRIES

44 SUMMER AVENUE, NEWARK 4, NEW JERSEY

EXPORT AGENTS: PHILIPS EXPORT CORP., 100 EAST 42nd STREET, NEW YORK 17, N. Y.



CHECK LIST

COMPONENTS FOR THE ELECTRONIC INDUSTRY

✓ CONNECTORS (AN Types)

- RECEPTACLES
- PLUGS
- CAPS
- CABLE CLAMPS

Pressurized — Waterproof
High Voltage — Capacitor



✓ CONNECTORS (RF Types)



- UHF
- BNC
- BN
- PULSE and TRIAX PULSE TYPES

✓ RACK & PANEL Types

- Special DT
- DTGS
- DTKS
- DT HIGH VOLTAGE
- DT MINIATURE

New 1954 Layout
Bulletin Available



✓ CABLE ASSEMBLIES



- STANDARD MOLDED
- SPECIAL
- RIGHT ANGLE
- COAXIAL

✓ MISC. COMPONENTS

- VIDEO JACKS—PLUGS
- SHORTING PLUGS
- SPECIAL JACKS—FEED THRU
- SWITCH BOOT
- SEALING-GASKETING DEVICES
- POLARIZED CONNECTORS
- UHF MOBILE ANTENNA
- ROTARY SHAFT SEALS
- CABLE CLAMPS



Write for
Catalog!

Skilled in Electronic Component Parts
**RESEARCH • DESIGN
ENGINEERING
MANUFACTURING**

H. H. BUGGIE, Inc.
726 STANTON STREET
TOLEDO 4, OHIO

FIRST CHOICE

where *Quality* counts

"F" Series RACKS by PAR-METAL

No. F-6618: Overall: 67 $\frac{3}{8}$ " x 22" x 18"
Panel Space: 61 $\frac{1}{4}$ " x 19"

No. F-8318: Overall: 83 $\frac{1}{8}$ " x 22" x 18"
Panel Space: 77" x 19"

Want "custom-quality" in a standardized, economical Rack? Here's the industry's top value.

- Front and rear doors.
- Streamlined, modern in design. Ruggedly constructed of furniture steel.
- Entire cabinet is welded together into an integral unit.
- Note: full adjustment of panel mounting angles is provided for, to position material at any distance from front or rear doors.
- Finishes: black ripple, grey ripple, aluminum grey lacquer (or prime coat only).

Planning an electronic product? Consult Par-Metal for

RACKS • CABINETS CHASSIS • PANELS

Remember, Par-Metal equipment is made by electronic specialists, not just a sheet metal shop.

Made by
*Electronic
Specialists*



PAR-METAL
PRODUCTS CORPORATION

32-62 — 49th ST., LONG ISLAND CITY 3, N. Y.
Tel.: Astoria 8-8905
Export Dept.: Rocke International Corp.
13 East 40 Street, New York 16, N. Y.

WRITE FOR CATALOG !

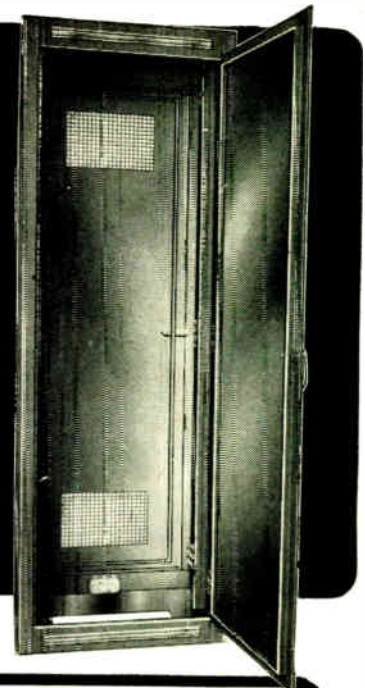

BLOCK UNITIZED PULSE INSTRUMENTS

- EACH INSTRUMENT COMPLETE—AND EXPANDABLE. UNITS MAY BE ADDED TO EXTEND RANGE AND APPLICATION.

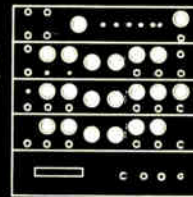

USE INDIVIDUALLY
OR IN MULTIPLE
COMBINATIONS

FUNCTION CHANGE EFFECTED BY SIMPLE SWITCH OF REAR PLUG-IN CABLE

PULSE GENERATOR

Model 2120A

- Internal sync. pulse source (10 cps to 100 KC)
- Variable main pulse delay (0 to 10,000 μ s)
- Variable width main pulse (.1 to 1,000 μ s)
- .02 μ s rise time main pulse
- Accurate, high resolution controls

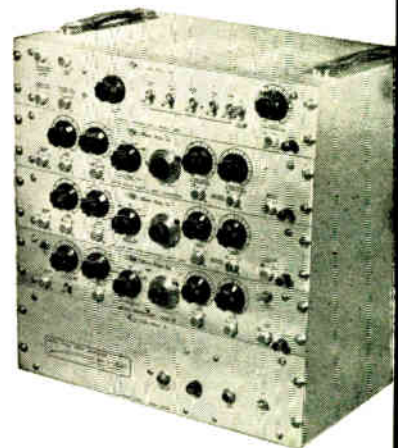

Write for complete specifications: our Bulletin No. 2100-1/A and the Name of Our Representative in your area.



Electro-Pulse, Inc.

11811 MAJOR STREET, CULVER CITY, CALIF.

EXbrook 8-6764



(Continued from page 124A)

- Appleberry, C. M., Jr., Thomas Electronics, Inc.,
118 Ninth St., Passaic, N. J.
- Arkwright, L. P., 507 Burgess Dr., Rochelle Park,
N. J.
- Asher, J. W., Box 382, Corning, N. Y.
- Baker, R. H., 375 Tavistock Blvd., Haddonfield,
N. J.
- Bartels, H. C., 2004 Hilltop Rd., Flourtown, Pa.
- Bates, J. F., 1615 Annandale Rd., Falls Church,
Va.
- Beatty, W.H., Valley Rd., R.F.D. 1, Millington, N.J.
- Belcher, H. P., 2021 S. Fillmore St. Arlington 4,
Va.
- Bennett, H. L., Box 460, Independence, Kans.
- Biss, M. W., 15 Transit Dr., Greenock Heights,
McKeesport, Pa.
- Black, V. G., 2619 Post Oak Rd. Houston, Tex.
- Blocki, W. G., Box 609, Matteson, Ill.
- Bolinger, N. C., 2613 Indiana, N.E., Albuquerque,
N. Mex.
- Bost, M. E., 738 Harvard St., Houston 7, Tex.
- Bowman, J., Jr., Technical Representation, 25 S.
Easton Rd., Glenside, Pa.
- Boyd, J. E., 146 Wayne Pl., S.E., Washington 20,
D. C.
- Bradley, F. B., 1507 Auline La., Houston 24, Tex.
- Braggins, R. D., 125 Woodward Ave., Kenmore 17,
N. Y.
- Bratt, M. J., 7462 Werner Ave., Cincinnati 31,
Ohio
- Breese, H. R., 139 Twin La., N., Wantagh, L.I.,
N. Y.
- Brown, M. H., 12521 S. 68 Ct., Palos Heights, Ill.
- Brush, J. W., Grubb Rd., Chevy Chase, Washing-
ton, D. C.
- Bryant, B. L., Jr., 263-23—73 Ave., Glen Oaks,
L. I., N. Y.
- Buffington, C. T., 39 Liberty, Westminster, Md.
- Burrows, R. C., Jr., 417 E. 12 St., Houston 8, Tex.
- Caines, H. R., 1919 S. Beechwood St., Philadelphia
45, Pa.
- Caras, B., 65 Lincoln Blvd., Long Beach, L. I.,
N. Y.
- Carpenter, L. B., 1624 Kingsway Rd., Baltimore 18,
Md.
- Carter G. D., 1300 Oakland Rd., Apt. 1210, Cedar
Rapids 1, Iowa
- Cass, J., 2032—61 St., Brooklyn 4, N. Y.
- Chappell, I. C., 69 Page St., Avon, Mass.
- Checketts, E. L., 9300 Claremont Ave., Alberquer-
que, N. Mex.
- Chew, Y. P., 361 King St., E., Toronto, Ont.,
Canada
- Chisholm, T. L., Jr., 110 W. 75 St., New York 23,
N. Y.
- Chu, T., 904 N.W. Eighth St., Oklahoma City,
Okla.
- Church, A. K., 800 S. 31 St., Lincoln 8, Nebr.
- Clayton, M. W., Earle Hotel, Rm. 304, Biloxi,
Miss.
- Cleary, R. E., Commercial Bank Bldg., Berea,
Ohio
- Cooper, C. B., 648 Second Ave., S., St. Petersburg 5,
Fla.
- Corning, J. J., 95 High St., Newburyport, Mass.
- Couch, L. J., Box 406, Emporium, Pa.
- Crowley, J. F., 32 Bay Ave., Bloomfield, N. J.
- Damme, M. C., 545 N. Grandview Ave., Papillion,
Nebr.
- DasGupta, A. K., Solar Manufacturing Corp.,
Seville & E. 46 St., Los Angeles, Calif
- Davis, B. L., Division 12.5, National Bureau of
Standards, Washington 25, D. C.
- Davis, R. B., Jr., A. D. Cardwell Electronics Prod-
ucts Corp., Plainville, Conn.
- Davison, C. O. C., 616 W. Cliveden St., Phila-
delphia 19, Pa.
- DeLisle, A. B. C., Box 3216, USAF, Wright-
Patterson AFB, Ohio

(Continued on page 150A)

A NEW TYPE RECTIFIER

For Closely Regulated D-C Voltage

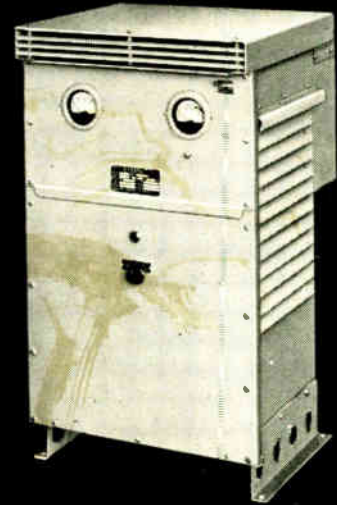

STAVOLT[®]

POWER RECTIFIERS

Closely Regulated
by Magnetic
Amplifier Control
of unique and
stable qualities.

Low Ripple
Fast Response

- Ten standard 28 Volt production models up to 1000 amperes, many others, mobile or stationary.
- Amazing size and weight reduction made possible by use of latest core and insulation materials and aluminum construction.
- Encapsulated components—shock mounted meters recessed behind plastic windows.
- No tubes—lamps—carbon piles—commutators or moving contacts and no radio interference.
- STAVOLT Rectifiers are rugged and can take heavy intermittent overloads. They meet MIL-E-7894 with both range and characteristics.

Engineers will be interested in learning more about the fine qualities of STAVOLT Rectifiers. Write for catalog with detail specifications.

McCOLPIN-CHRISTIE CORP.

3400 West 67th Street, Los Angeles 43, Calif.

25th Year of Rectifier Manufacturing

EBY PRINTED CIRCUIT SOCKETS

7 pin miniature for printed circuit use—the first of a series of high quality sockets for this service—by EBY

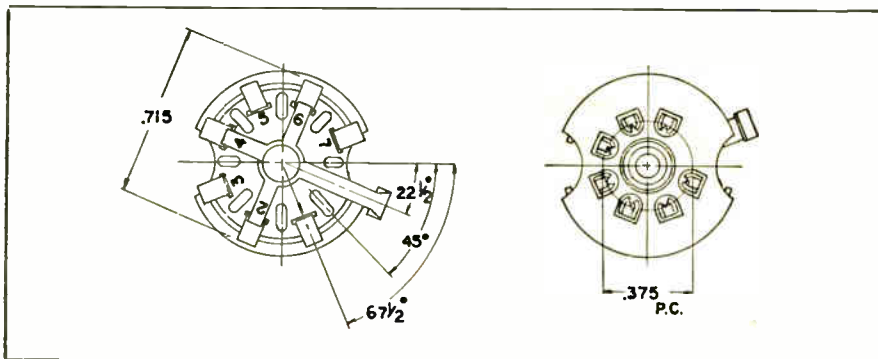
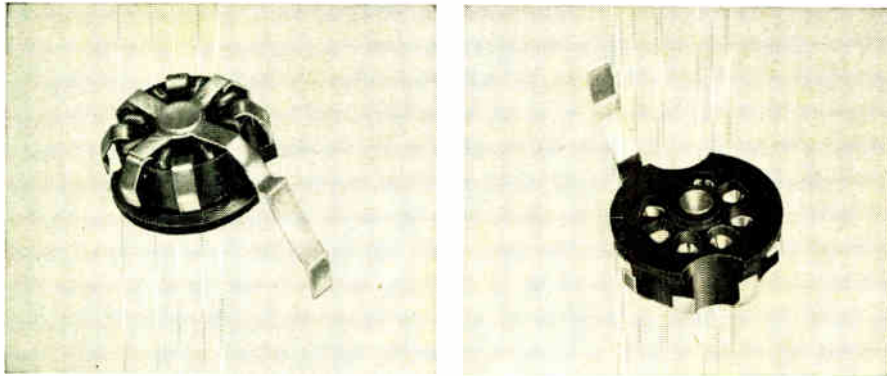

FEATURING

1. Snap action contacts fit snugly in chassis and hold socket in place for subsequent operations.
2. Spoke-type (non-rotating) center ground permits positive grounding of any or all contacts as specified.—also provided with long strap for grounding tube shield.
3. Available in low-loss or general purpose phenolic.
4. Contacts of standard miniature type design, with two lengths of tail—long for top side soldering.

Write for complete details, and samples.

HUGH H. EBY INC.

4702 Stenton Ave., Phila. 44, Pa.

News—New Products

These manufacturers have invited PROCEEDINGS readers to write for literature and further technical information. Please mention your I.R.E. affiliation.

(Continued from page 120A)

Thomas to Produce Lawrence Color Tube

Thomas Electronics' President, Thomas L. Clinton, and Richard Hodgson, President of Chromatic Television Laboratories, Inc., signed an agreement recently which made Thomas the first licensed producer in the East of the Lawrence single-gun color TV picture tube.



The single gun principle, in addition to permitting a large picture, is both cheaper to produce and simpler to operate than the three-gun color tube previously experimented with by other companies. Hodgson stated that the Lawrence color tube gives a higher quality black-and-white reproduction than the standard telecasting of today. Thomas Electronics said that the Lawrence tube is one-third larger than present color tubes but that its design will permit its use in cabinets much smaller than those used previously for color sets.

Pioneers in making TV tubes, Thomas now uses 225,000 square feet of space in its Passaic, N. J. plant. The company turns out about 30 different types of black-and-white tubes.

Transistor Transformers

Microtran Co., Div., Crest Laboratories, Inc., announces the introduction of a line of miniature transformers, designated as Veri-Miniature transformers:

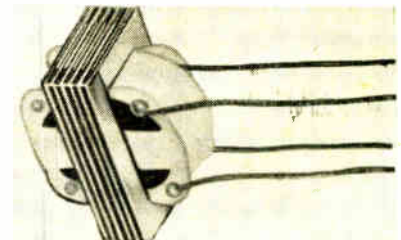

Designed for use in transistorized circuitry, such as hearing aids and radio paging, they are available for input, interstage, output, and choke applications. Their size is: $\frac{1}{8} \times \frac{1}{2} \times \frac{1}{8}$ inches. Frequency response is flat from 300 to 10,000 cps.

In addition to standard items, special units can be constructed upon receipt of customer's specifications. Full details are available upon request.

(Continued on page 153A)

Florida



The New Horizon of INDUSTRY

The South, and Florida in particular, has risen to a new status in the engineering and manufacturing fields. Many industries, old and new, have located here in line with decentralization policy and to take advantage of the many potentialities of the area. Lower living costs, low taxes, and year 'round outdoor life appeal to both labor and management.

Engineering firms, especially, find Florida an ideal location in which to conduct operations. As an index to the growth of the electronic industry in the state, the number of IRE members in Florida has increased over 300% in the last three years. There is no doubt that the future is in Florida.

RADIATION, INC. is one of many engineering firms to locate in Florida. Engaged in electronic research and development, our work includes the fields of avionics, nucleonics, and automation.

Our engineers enjoy the low living costs and pleasant living conditions of the area plus the opportunities offered by a progressive, expanding organization.

Qualified engineers with experience in electronic circuit design, aircraft instrumentation, and stress analysis are invited to contact R. L. Bickford, Director of Personnel, RADIATION, INC., P. O. Drawer Q, Melbourne, Florida.



RADIATION Inc.

Electronic RESEARCH · DEVELOPMENT · PRODUCTION

Melbourne, Fla.
Orlando, Fla.

Communication Engineers

with
experience
in
the
fields
of

**Systems
Engineering**
**Digital
Techniques**
**Circuit
Development**
**Electro-
mechanical
Development**
**Equipment
Engineering**

Advancements in the fields of wave propagation, translation of information, communication theory, circuit techniques and equipment miniaturization have created a number of new openings for qualified engineers in the Hughes Advanced Electronics Laboratory.

THE COMPANY

Hughes Research and Development Laboratories, located in Southern California, form one of the nation's leading electronics organizations. The personnel are presently engaged in the development and production of advanced electronics systems and devices.

AREAS OF WORK

The communication group is concerned with the design and development of unique radio communication systems and with exploiting new radio communication techniques. People whose interests lie in the fields of propaga-

tion phenomena, antenna systems, network theory, magnetic recording, digital techniques, and intricate electromechanical devices are needed in this program.

THE FUTURE

Engineers who enjoy a variety of problems requiring originality and ingenuity find the proper environment for personal advancement in these activity areas. Widespread future application of advanced communication techniques will enable the Hughes engineer to take full advantage of his experience as the Company expands commercially.

Write today, giving details of qualifications and experience. Assurance is required that relocation of the applicant will not cause disruption of an urgent military project.

How to apply

Hughes

RESEARCH AND DEVELOPMENT LABORATORIES

Scientific
and
Engineering
Staff

CULVER CITY,
LOS ANGELES
COUNTY,
CALIFORNIA



TRANSFORMER ENGINEER

Large New England electronics manufacturer has opportunities in Transformer Div. for electrical engineers interested in design of specialized transformers or in development of equipment using magnetic circuits such as filters, voltage regulators, etc. There are presently openings for both experienced and inexperienced people. Graduate study opportunities available under complete tuition refund plan. Send resume to L. B. Landall, Raytheon Manufacturing Co., 190 Willow St., Waltham, Mass.

TRANSFORMER ENGINEER

Established manufacturer of small transformers for radio and TV industry require experienced engineer to design transformers to customer's specifications, supervise the building of samples, also to design production test equipment. Only those with at least 5 years experience, able to furnish references, need apply. Generous salary. Box 761.

TELEVISION BROADCAST TECHNICIANS

CBS Television Network has openings for assistant Technicians (\$72.50 per week) and full Technicians (\$76.50 to \$150.00 per week) in all branches of television operations, maintenance and construction. Engineering background, radio knowledge, aptitude and ability to work with others are more important than past television experience. Apply CBS Television Operations, 524 West 57th St., New York, N.Y.

INSTRUMENTATION ENGINEER

Graduate EE with industrial instrumentation design experience for development laboratory of old established company in mid-west. Servomechanism experience necessary. Bowser Inc., Fort Wayne 2, Indiana.

PROJECT ENGINEER

Project Engineer (Loudspeakers) for acoustic and audio development. Must have good background in loudspeakers, microphones and physics of moving systems as pertains to audio frequency transducers. Challenging opportunity; salary commensurate with experience. Progressive manufacturer located in New York suburban area. Box 762.

ENGINEERS

M. E. Minimum of 10 years experience in electronics, must have been Chief or Assistant Chief Mechanical Engineer for electronic firm. 1. Flyback Transformer Engineer experienced in design of horizontal deflection circuits and yokes. 2. Capacitor Engineer experienced in electrical phases of ceramic and mica capacitor design. Administrative Coil Engineer with heavy experience in circuitry and coil design. Mail resumes to Personnel Director, Automatic Manufacturing Corp. 256 Passaic St., Newark, New Jersey.

TRANSFORMER DESIGN ENGINEER (Audio & Power)

Salaried position, 1 year minimum design experience required. Age between 25 and 35 years old. Write Personnel Mgr., Columbus Process Co., Inc., Columbus, Indiana for further details. Enclose brief summary of educational background and design experience.

INSTRUCTOR

Instructor, Technical Electricity to teach course in power and electronics at the technical institute level. At least a BS. with some industrial experience and interest in laboratory work. Salary \$4500 to \$6000. Location Central New York state. Box 763.

(Continued on page 132A)

RCA OPENS NEW HORIZONS in AVIATION ELECTRONICS!



ADVANCE THE SCIENCE OF

**FIRE CONTROL • PRECISION NAVIGATION
COMMUNICATIONS**

**You'll find challenge in: Systems, Analysis,
Development or Design Engineering**

And You Can Specialize In: Radar • Analog
Computers • Digital Computers • Servo-
Mechanisms • Shock & Vibration • Circuitry
• Heat Transfer • Remote Controls • Sub-
Miniaturization • Automatic Flight • Transis-
torization • Design for Automation

You Should Have: Four or more years' pro-
fessional experience and your degree in electrical
or mechanical engineering, or physics

You'll find unlimited opportunities for professional advancement in RCA's broadened aviation electronics program! Suburban or country living nearby. Relocation assistance available.

And at RCA, you'll move ahead through *learning* as well as *doing* . . . for RCA encourages you to take engineering *graduate* study with company-paid tuition. You'll also enjoy professional status . . . recognition for accomplishment . . . unexcelled facilities . . . *many* company-paid benefits.

Your RCA career can start now! Begin by sending a resume of your education and experience to: **Mr. John R. Weld, Employment Manager**
Dept. B-453E, Radio Corporation of America
Camden 2, New Jersey



RADIO CORPORATION OF AMERICA

Tmks. ®

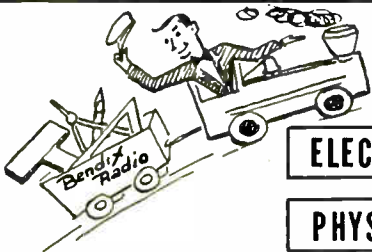

Full Steam Ahead

ELECTRONICS ENG.

PHYSICISTS

MECHANICAL ENG.

with
**BENDIX
RADIO**

It's full steam ahead at Bendix Radio . . . More work to be done! More experienced engineers needed! More interesting, challenging positions to be filled! Your future is bright when you join the efficient Bendix Radio team!

Excellent salaries.

Semi-annual work reviews with advancement on merit.

Modern, air-conditioned plant located in beautiful suburban area with ample housing, good schools, attractive shopping centers, major league sports.

Numerous employee benefits.

**Challenging work in
The development of:**

Radar (Airborne and Ground)

Auto Radio and Test Equip.

Airborne & Mobile Comm. Equip.

Missile Guidance Systems

Computer Applications

Research & Development

(Incl. Transistors and Printed Circuitry)

Call, wire or write Mr. L.H. Noggle, Dept. M

Bendix Radio

DIVISION OF BENDIX AVIATION CORP.

BALTIMORE 4, MD.

Valley 3-2200

POSITIONS OPEN

(Continued from page 130A)

MICROWAVE TUBE ENGINEERS

Several opportunities at both senior and junior levels for electronic engineers or physicists interested in research and development in the field of microwave vacuum tubes with emphasis on travelling wave tubes, backward wave oscillators, klystrons and carcinotrons. Graduate study opportunities available under company tuition refund plan. Send resume of background and experience to L. B. Landall, Raytheon Manufacturing Co., 190 Willow St., Waltham, Mass.

CHIEF DEVELOPMENT ENGINEER

Require man with sound background in electronics and a reasonable working knowledge of mechanical engineering. Prefer MS. or Ph.D. degree in Electrical Engineering plus 5 or more years' experience. Will consider other educational backgrounds. Starting salary \$10,000 per year. Box 765.

ELECTRONIC ENGINEERS

The Civil Aeronautics Administration has openings for electronic engineers to work on Radio Aids to Air Navigation. Previous experience not essential. Work consists of installing, testing and making performance evaluation study on UHF, VHF and radar equipment. Most assignments will require continuous travel throughout 15 northeastern states. Travel expenses plus salary. Reply in person or write to Personnel Branch, Civil Aeronautics Administration, Federal Bldg., N.Y. International Airport, Jamaica, N.Y.

(Continued on page 134A)

**ENGINEERS
DESIGNERS**

Investigate opportunities at

ERCO

ENGINEERING
& RESEARCH
CORPORATION

DRAFTSMEN

We point to our achievements at ERCO with pride . . . to the Ecoupe, our electronic flight simulators, machine tools, and armament products, which we have designed and built . . . to the plant which offers diversified tools for electro-mechanical and mechanical fabrications, enabling us to build what we design . . . to the men who work at ERCO and who have made this progress possible.

But we are constantly on the alert for new men to add fresh impetus to that progress . . . paying top salaries to capable people.

ERCO is convenient too—whether you drive, ride, or fly. Transit and railway lines are handy, parking facilities are ample, and ERCO Field is available to those who fly.

You can choose a home from a number of fine nearby residential areas convenient to both shopping centers and plant . . . and you can further your education at the many nearby universities.

You will find that although ERCO is the largest privately owned design and manufacturing plant in the Washington area, it is small enough to recognize and reward individual initiative.

ERCO now needs Electronic Engineers (all levels with some overseas positions available), Aerodynamicists, Computer Engineers, Mechanical Designers, and Machinery Designers. For further information, call WA. 7-4444—ext. 106.

ENGINEERING AND RESEARCH CORPORATION

RIVERDALE · MARYLAND

ANTENNA ENGINEER

For an interesting and stimulating assignment in the Microwave Laboratory of our Airplane Engineering Division.

Candidates must have B.S.E.E. degree and a minimum of two years experience in antenna design or microwave testing techniques.

Excellent compensation and assistance in relocating to qualified applicant. Address confidential inquiries to:

Technical Placement Supervisor

Box 516, St. Louis 3, Missouri

Mc DONNELL

AIRCRAFT CORPORATION

ST. LOUIS, MO.

A career in

advanced electronic development

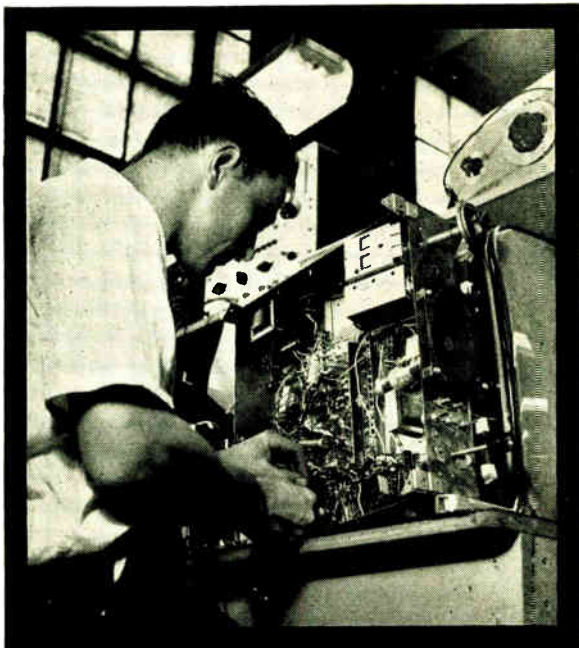

Designers for Industry, Inc. is helping many well-known electronics manufacturers meet the "challenge of change" by providing a pool of technical talent unsurpassed by any product development organization.

Our 180-man engineering organization not only generates product ideas. We are also equipped, by experience and facilities, to carry the project through its various stages of development to a final, tested, pre-production model.

In the Electronics field, the DFI organization has built a particularly strong background in miniaturization and modular construction techniques. Some of the many types of development projects we handle are listed below.

Opportunities for unlimited advancement are available at DFI for engineers who have proven records in electronics, electrical, electromechanical, hydraulic and mechanical engineering. Write for further information regarding opportunities in creative engineering work at DFI, as well as DFI employee benefits.

**DFI development
work in electronics
includes:**

COMMUNICATIONS
VHF, UHF, and HF Receivers
Television Receivers
VHF and UHF Transmitters
Microwave Systems
Mobile and Specialized
Military Equipment

MISSILE GUIDANCE
Systems
Servomechanisms

RADAR
Circuitry
Servo Systems
Display Systems
Mechanisms
Beacons
Systems
Fire Control

CONTROLS
Electromechanical
Servomechanisms

COMPUTERS
Test Equipment
Systems Planning
Circuitry
Servomechanisms
Intricate High-speed
Mechanisms

COMPONENT PARTS
Mechanisms
Evaluation Programs
Special Components

DESIGNERS FOR INDUSTRY, Inc.

2915 Detroit Avenue • Cleveland 13, Ohio
Established 1935



UNLIMITED OPPORTUNITIES for . . . Electrical Engineers and Physicists to do Digital Computer Engineering

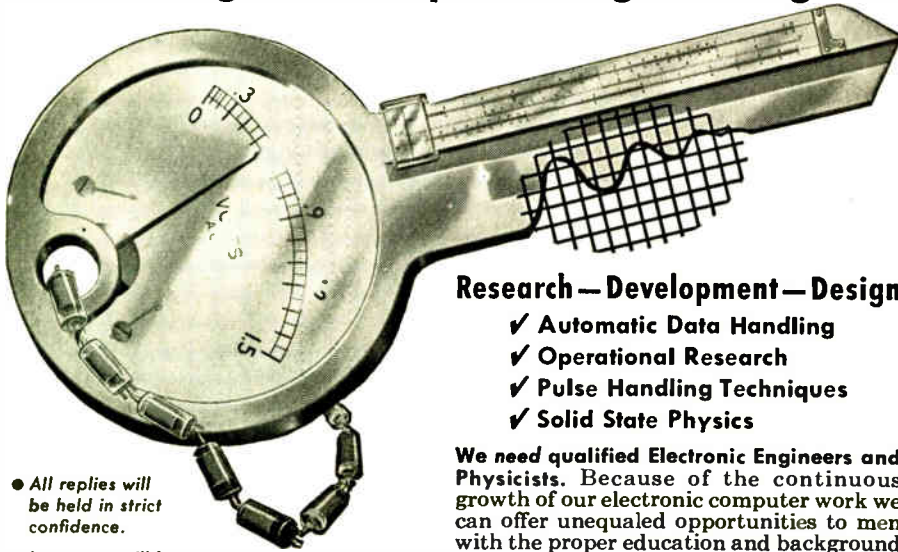

- All replies will be held in strict confidence.
- Interviews will be arranged at our expense.

Research — Development — Design

- ✓ Automatic Data Handling
- ✓ Operational Research
- ✓ Pulse Handling Techniques
- ✓ Solid State Physics

We need qualified Electronic Engineers and Physicists. Because of the continuous growth of our electronic computer work we can offer unequaled opportunities to men with the proper education and background in the Electronics field . . . permanent positions, financial security, professional development.

HERE IS THE KEY TO YOUR FUTURE...

ENGINEERING RESEARCH ASSOCIATES
DIVISION OF **Remington Rand**
1902 West Minnehaha Avenue St. Paul W4, Minnesota

production and design **ENGINEERS** FOR TV COMPONENTS

One of the world's largest manufacturers of electronic components since 1921 — plants in the east and midwest — offers you the opportunity to grow in a dynamic organization.

Are you a qualified engineer, preferably experienced in TV tuners and sweep circuit components?

We invite you to write to us today, detailing your experience in this field.

Address all replies to: Director Industrial Relations,
General Instrument Corporation
829 Newark Avenue, Elizabeth, New Jersey



(Continued from page 132A)

PHYSICIST OR ELECTRICAL ENGINEER

Practical physicist or electrical engineer for design and development of nondestructive testing instruments. We are a small company located in New York City—in business over 25 years and are not engaged in Government contract work. Reply fully to Box 766.

DIVISION HEAD

Well established medium sized precision watch parts manufacturer now entering the field of industrial electronic instruments and controls seeking fully experienced engineer with successful record in both engineering and management; able to create original products and build a manufacturing division to substantial size. Should have knowledge of market and sales potentials. Location metropolitan New Jersey. Box 767.

ENGINEER

Manufacturer of electrical indicating instruments requires men with experience in design of D'Arsonval Dynamometer and Iron Vane type meters. Engineering degree not essential. Experience will qualify. In reply give full details of education and experience and salary requirements. Box 768.

ENGINEERS

1—ELECTRONIC: Minimum of 5 years experience in circuit design with primary emphasis on pulse circuitry and high frequency RF technique.

2—MECHANICAL: Minimum of 5 years experience in packaging electronic equipment as well as in mechanical design of small electro-mechanical devices.

This company engaged in the field of telemetering, developing and producing transmitters, receivers, data treating equipment and special electronic and electro-mechanical devices, offers permanent positions with liberal benefits. Send complete resume to Applied Science Corporation of Princeton, P.O. Box 44, Princeton, N.J. Tel. Plainsboro 3-4141.

SPECIAL PROJECTS ENGINEER

Our newly established Field Service and Technical Training Unit is preparing for expanding operations. We need an electronics engineer or physicist who enjoys a challenging variety of work with advanced types of electro-mechanical systems. Experience in any of the following is desirable: radar autopilots, radio command, servos, computers, communications, telemetering, field engineering, teaching. Liberal relocation allowance to Downey. Write to Engineering Personnel, Missile and Control Equipment Depts., North American Aviation, Inc., 12214 Lakewood Blvd., Downey, Calif.

IRE DIRECTORY

Listings close May 30th

Copy to set deadline

June 1st,

Complete plate deadline

June 15th

important engineering opportunities

WITH
MAGNAVOX

Permanent positions to Senior and Project Engineers, with mechanical or electrical design experience, are offered by Magnavox, creative leaders in the electronics industry.

**OPPORTUNITIES
IN:**

SYSTEMS
DIGITAL COMPUTERS
SERVO SYSTEMS
COMMUNICATION
NAVIGATIONAL AIDS
FIRE CONTROL
MICROWAVE
ANTENNAE
SONAR
RADAR

Please forward complete resume
to:

MR. GEORGE D. MC CLAREN

**THE
MAGNAVOX
COMPANY**
FORT WAYNE, INDIANA

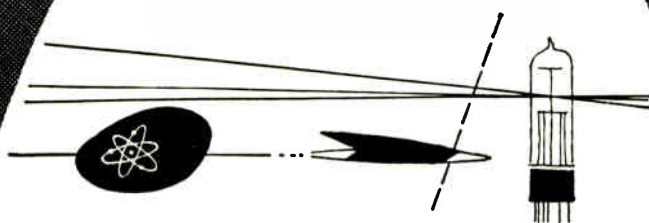

**ELECTRONIC
ENGINEERS:**

Westinghouse
is a **CAREER!**

Long-range expansion programs in two Westinghouse divisions have created excellent ground-floor openings in *career* positions.

AIR ARM DIVISION:

World-leader in the field of aviation - electronics. Work involves computer, autopilot, radar and other advanced projects.

ELECTRONICS DIVISION:

Currently developing highly specialized equipment such as radar, electronic computers and guided missile ground control devices.

THESE DIVISIONS HAVE OPENINGS FOR —

**ELECTRICAL ENGINEERS • MECHANICAL ENGINEERS
PHYSICISTS • MATHEMATICIANS • FIELD SERVICE
ENGINEERS • ENGINEERING TECHNICAL WRITERS**

OPPORTUNITIES AND ADVANTAGES

PROFESSIONAL RECOGNITION	Opportunities for advanced study at company expense, and liberal <i>patent disclosure compensation</i> .
WORKING ATMOSPHERE	Both professional and friendly. Association with the leading scientists and engineers in their fields.
SALARY	Salary compensation individually determined according to experience and ability, and promotions based on individual merit.
HOUSING CONDITIONS	Excellent. Fully described and pictured in "Gateway to an Engineering Future," our new brochure.

SEND TODAY FOR BROCHURE AND APPLICATION!

Address: R. M. Swisher, Jr.
Employment Supervisor, Dept. MA-3
Westinghouse Electric Corporation
109 West Lombard Street
Baltimore 1, Maryland

YOU CAN BE SURE...IF IT'S
Westinghouse
BALTIMORE DIVISIONS

It's the Individual that counts at MELPAR...



NO ENGINEER becomes just a "cog in the wheel" at Melpar. Instead, everybody has his own responsibility — is rewarded and advanced for a job well done. That's why so many young engineers hold the top jobs here. Melpar is growing and new top jobs open up regularly. Maybe you're just the man for one of them. Why not find out — now!

Experience desired in one or more of these or allied fields: Data Handling Equipment (magnetic cores, magnetic recording equipment, analogue to digital conversion, shaft digitizers) • Flight Simulation (servomechanisms, pulse circuitry, electronic cabling) • High Frequency Antennas • Audio and Video Circuit Design • Small Mechanisms Design • Mechanical Packaging and Electronic Components • Heat Transfer and Thermodynamics • Design of reciprocating compressors, hot gas generators and diesel engines

Address: Personnel Director, Dept. IR6-5



Galen Street, Watertown, Mass. • 440 Swann Ave., Alexandria, Va.

A SUBSIDIARY OF THE WESTINGHOUSE AIR BRAKE COMPANY

CHIEF ENGINEER

Important electronics organization in metropolitan New York with engineering staff of 100, requires a mature Chief Engineer with heavy experience in design and development of radio and radar transmitters, receivers and test equipment; servos, telemetering, computers, scalars and related equipment.

Should have adequate academic background and be a strong administrator, a meticulous analyst; know military specifications, be capable of estimating and preparing bids and proposals, evaluating and negotiating technical terms and conditions of military contracts, and be skilled in engineering load planning and scheduling of prototype production.

Our staff knows of this ad. Submit resume to

President, Box 769

INSTITUTE OF RADIO ENGINEERS

1 East 79 St.

New York 21, N.Y.

ELECTRICAL ENGINEER

Our Engineering and Developing Department needs a recent Electronic engineering Graduate, preferably with a Master's Degree, to work on Electronic Digital computing equipment. Computing experience desirable but not essential. Location will be in Chicago.

In reply please state age, education, past employers, salaries earned, address and phone number for early interview. Replies will be kept in strict confidence.

BOX 770

INSTITUTE OF RADIO ENGINEERS

1 East 79 Street

New York 21, N.Y.



Positions Wanted By Armed Forces Veterans

In order to give a reasonably equal opportunity to all applicants and to avoid overcrowding of the corresponding column, the following rules have been adopted:

The Institute publishes free of charge notices of positions wanted by I.R.E. members who are now in the Service or have received an honorable discharge. Such notices should not have more than five lines. They may be inserted only after a lapse of one month or more following a previous insertion and the maximum number of insertions is three per year. The Institute necessarily reserves the right to decline any announcement without assignment of reason.

TRANSLATOR

BSEE University of California, 1950; Age 25. Excellent knowledge of Russian; 2 years teaching experience Signal Corps; 7 months radio and electrical engineer, currently graduate student desiring some free lance work translating technical Russian literature. Box 708 W.

ENGINEER—EXECUTIVE

BEE, MEE, BBA; 15 years comprehensive experience planning, development, application of electronic automatic control systems involving radar, computers, data handling, displays; creative and administrative ability; seeks non-defense management opportunity. Box 711 W.

(Continued on page 138A)

ENGINEERS

The APPLIED PHYSICS LABORATORY OF THE JOHNS HOPKINS UNIVERSITY offers an exceptional opportunity for professional advancement in a well-established laboratory with a reputation for the encouragement of individual responsibility and self-direction. Our program of

GUIDED MISSILE

RESEARCH AND DEVELOPMENT

provides such an opportunity for men qualified in:

- ELECTRONIC CIRCUIT DESIGN AND ANALYSIS
- DEVELOPMENT AND APPLICATION OF TRANSISTOR CIRCUITRY
- SERVOMECHANISMS AND CONTROL SYSTEM ANALYSIS
- ELECTRONIC EQUIPMENT PACKAGING INSTRUMENT DESIGN
- MISSILE SYSTEMS DEVELOPMENT
- FLIGHT TEST PROPOSALS AND DATA ANALYSIS

Please send your resume to

Glover B. Mayfield

APPLIED PHYSICS LABORATORY

THE JOHNS HOPKINS UNIVERSITY

8621 Georgia Avenue
Silver Spring, Maryland

CERAMIC ENGINEER

- *take charge of division ceramics laboratory in Boston area*

Sylvania's Electronics Division offers a significant opportunity to an experienced ceramic engineer to take charge of the division Ceramics Laboratory in its new, air-conditioned plant at Woburn, Mass. The man we seek will attack problems common to development and production on all types of glass used in electronic devices; and he will conduct research programs dealing with ceramic-type electronic components such as Zirconates, Ferrites, Quartz, etc. Graduate degree in ceramics or equivalent in experience is essential.

Conveniently located just outside Boston, Woburn offers an ideal environment for family living and excellent facilities for advance studies at nearby universities.

Please forward complete resume to:

MR. ROBERT L. KOLLER

SYLVANIA

ELECTRIC PRODUCTS INC.

Electronics Division
Woburn, Mass.

Career Opportunities

for

- MECHANICAL ENGINEERS
- ELECTRONICS ENGINEERS
- ELECTRICAL ENGINEERS
- X-RAY ENGINEER
- PHYSICISTS
- AERODYNAMICISTS
- MATHEMATICIANS

➤ Sandia Corporation, a subsidiary of the Western Electric Company, offers outstanding opportunities to graduates with Bachelor's or advanced degrees, with or without applicable experience, in the above fields.

➤ Engineers and scientists at Sandia Laboratory, an atomic weapons installation, work as a team at the basic task of applying to military uses certain of the fundamental processes developed by nuclear physicists. This task requires applied research as well as straightforward development and production engineering.

➤ The place of an engineer or scientist on the Sandia team is determined initially by his training, experience, and talents . . . and, in a field where ingenuity and resourcefulness are paramount, he is afforded every opportunity for professional growth and improvement.

➤ Sandia engineers and scientists design and develop complex components and systems that must function properly under environmental conditions that are much more severe than those specified for industrial purposes. They design and develop electronic equipment to collect and analyze test data; they build instruments to measure weapons effects. As part of their work, they are engaged in liaison with the best production and design agencies in the country, and consult with many of the best minds in all fields of science.

➤ Sandia Laboratory, operated by Sandia Corporation under contract with the Atomic Energy Commission, is located in Albuquerque — a modern, mile-high city of 150,000 in the heart of the healthful Southwest. Albuquerque offers a unique combination of metropolitan facilities plus scenic, historic and recreational attractions; and a climate that is sunny, mild, and dry the year around. New residents have little difficulty in obtaining adequate housing.

➤ Liberal employee benefits include paid vacations, sickness benefits, group life insurance, and a contributory retirement plan. Working conditions are excellent, and salaries are commensurate with qualifications.

Make Application to:
PROFESSIONAL EMPLOYMENT
DIVISION A

SANDIA

Corporation

SANDIA BASE • ALBUQUERQUE, NEW MEXICO



OPENING FOR ELECTRONICS ENGINEER AT GILFILLAN

Naturally, no man takes a job because of climate alone. But when year-long fun under the sun is a *bonus* — added to everything you have been looking for in a lifelong career, including rapid advancement, interest, security and prestige—that's different.

That is what a job with Gilfillan can mean to a qualified engineer. To you, now, because Gilfillan has several openings for good men.

SECURITY

Gilfillan is a major company, with 7 plants located throughout Southern California, that has been in business more than 40 years.

SATISFACTION

Gilfillan is big enough to handle all phases of engineering research, design and production, yet not so big you get lost. You have the very real satisfaction of following through on your work, getting credit for it, and seeing its achievements in the field.

PRESTIGE

Gilfillan pioneered GCA Radar and all its major improvements, and is at present engaged in automatic GCA, missile guidance, navigational systems, E. C. M.—and a series of classified projects

involving advanced and unsolved techniques for all branches of the military services.

Work is interesting at Gilfillan because ideas begin here. As a Gilfillan engineer, your value increases — because of the Gilfillan reputation, and because you work in coming fields.

ADVANCEMENT

You go ahead at Gilfillan as fast as you are ready. You are paid, and advanced, according to ability, not seniority. If you want further formal training, Gilfillan pays your tuition at UCLA or USC. You can be sure your ability will be recognized, because every man in a supervisory capacity at Gilfillan is a qualified engineer.

WRITE:

R. E. Bell, Gilfillan Bros., Dept. 54, Venice Blvd., Los Angeles, California. Give a brief resume of your background and experience. Interview at a convenient location will be arranged for qualified men.



Positions Wanted

(Continued from page 136A)

ENGINEER

BSEE 1951; age 26; 1 child. 2½ years experience in Airborne navigation systems. Desires foreign assignment with suitable living conditions for family. Box 710 W.

ELECTRONICS RESEARCH

BEE 1946, MEE 1950 electronics. Age 28, married, one child. 3 years experience radio navigation systems research, creative design, construction, analysis, laboratory and field evaluation. Officer Naval Reserve. Presently employed Government research activity. Desires similar position with advancement opportunity industry or university research program. Box 713 W.

ENGINEER

SB. and SM.EE, Massachusetts Institute of Technology 1950, 1951. Member of Eta Kappa Nu, Tau Beta Pi, Sigma Xi. 2 years development experience in analogue computers, servo-mechanisms and relay switching circuits. Age 27. Desires position with future. Anywhere in U.S.A. Will not consider classified work. Box 715 W.

ENGINEER

BEE. Rensselaer Polytechnic Institute, 1942. Graduate work in physics. Seeks management opportunity with progressive New England firm. Broad and practical experience in project direction including present position as Chief Engineer. Specialist in electromagnetic engineering and microwave circuits. Box 716 W.

(Continued on page 140A)



ENGINEERS

Have you developed a "Success Perspective"?

If a year or two of practical experience has given you the youthful maturity that demands more than just a job, you may be interested in our "career opportunities" in color TV, crystal products and electronic tubes.

Submit resume or address request for personal interview to D. Bellat, Personnel Director.

TUNG-SOL ELECTRIC INC.
200 Bloomfield Avenue
Bloomfield, N.J.

Recent technical advances at **HUGHES** have created new openings with exceptional opportunities for full use of technical judgment and inventive ability.

staff engineer...
ELECTRONICS

With extensive background and qualifications for assuming responsibility for development of automatic guidance systems utilizing radar, infrared or sonar.

aerodynamicist

With experience in supersonic aerodynamics and the ability to evaluate the performance and stability of supersonic aircraft.

hydrodynamicist

With experience in design of hydrodynamic features of underwater weapons and the ability to evaluate the performance and stability of such missiles.

ALL REPLIES
HELD IN
STRICT CONFIDENCE

Hughes

TOOL COMPANY
Aircraft Division
11940 JEFFERSON BLVD.
Culver City, California

If you meet the above qualifications, and wish to locate in Southern California, you are invited to write for further information regarding these positions. Include your resume, and a telephone number where you may be reached for an interview.

SALARY COMMENSURATE
WITH QUALIFICATIONS

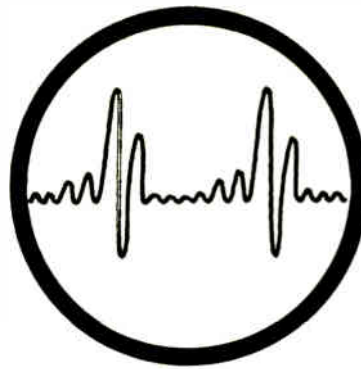

**SPECIAL OPPORTUNITIES FOR
SENIOR ENGINEERS**

Convair in beautiful, sunny San Diego invites you to join an "engineers" engineering department. Interesting, challenging, essential long-range projects in commercial aircraft, military aircraft, missiles, engineering research and electronics development. Positions open in these specialized fields:

Electrical Design	Servo-mechanisms
Mechanical Design	Aerodynamics
Structural Design	Thermodynamics
Structures	Operation Analysis
Weights	System Analysis

Generous travel allowances to those accepted. For free brochure, write Mr. H. T. Brooks, Engineering Dept. 800

CONVAIR
IN BEAUTIFUL
SAN DIEGO

3302 PACIFIC HIWAY
SAN DIEGO 12, CALIFORNIA

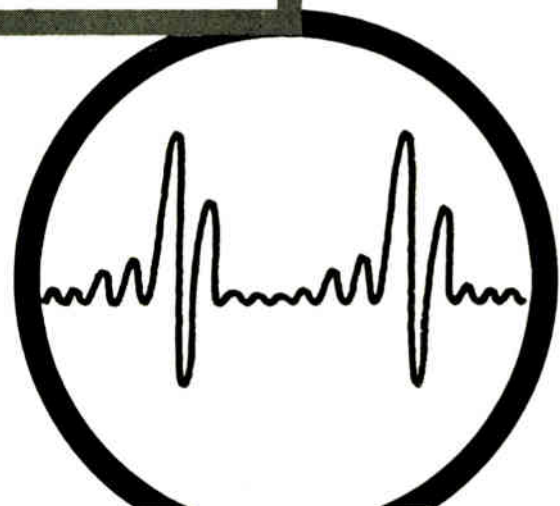



LEADERS and SPECIALISTS in ENGINEERING

offered splendid opportunities in
Boston Engineering Laboratory!

Men qualified to handle high level assignments in electronics are offered a challenging opportunity in Boston, under ideal working conditions divorced from production. The laboratory provides stimulating projects, an atmosphere of scientific progress and provides assistance towards your personal advancement or professional recognition. You will work with a top level technical staff possessing the finest facilities. Administrative positions are open to men qualified to guide the efforts of others.

MICROWAVE ENGINEERS

Senior engineers to handle design and development projects and provide technical direction of other top-level engineers working on microwave circuits and microwave plumbing in the development of military airborne electronic equipment. Should have 5 years' experience in such work and at least a BS degree.

ELECTROMECHANICAL ENGINEERS

Senior engineers to direct groups of top level engineers working on mechanical designs of airborne electronic equipment. Should be able to estimate operating and development expenses to judge and coordinate staff work. Should have 5 years' experience in the field and at least a BS degree.

ELECTRONIC Engineer-in-Charge

To plan, direct and control the activities of engineers engaged in design and

development of large, complex electronic equipment. Must have at least 5 years' experience in military electronic equipment and be familiar with latest techniques used in airborne electronic methods. Must have at least a BS degree.

ENGINEERING SPECIALIST (Weight Control)

Experienced in the mechanical design of airborne electronic equipment. Should have a BS degree and approximately 5 years' experience in aircraft weight control and high strength-to-weight ratio structures. Should be qualified to direct the work of a group of engineers.

RADAR SYSTEMS AND CIRCUIT ENGINEER

To assume responsibility for electronic circuit design for major elements of complex airborne electronic equipment. Should have a BS degree and about 5 years' experience.

Sylvania provides financial support for advanced education as well as a liberal insurance, pension and medical program. Investigate a career with Sylvania.

INTERVIEWS BY APPOINTMENT

Don Bradley, Personnel Manager
Boston Engineering Laboratory

SYLVANIA

ELECTRIC PRODUCTS INC.



70 Forsyth Street • Boston, Massachusetts • KENmore 6-8900

Positions Wanted

(Continued from page 138A)

ENGINEER

Competent engineering group, experienced in radar, instrumentation and data reduction systems; wishes to contact persons interested in backing an electronic engineering company in Southern California. Box 714 W.

ELECTRONIC ENGINEER

BEE 1946, graduate work in EE, Married, Age 31. Experience in commercial TV; 3 years in application and test of electronics components used in airborne gear to Government specifications. Desires position on Government contract work in N.Y. Metropolitan area. Box 717 W.

PHYSICIST—ELECTRONIC SCIENTIST

Single, age 25, veteran. BS. in Engineering Physics 1951 New York University. Desires position in either research and development or overseas Field Engineering. Experienced in commercial and Military microwave communications systems, also has experience in transistor theory and applications. Box 718 W.

ENGINEER

B. Engr. mechanical and electrical major Feb. 1950. Age 32, married. 3½ years Navy instrument electrician. Experienced product engineer, ASME and ASTM inspection. Desires quality control, plant maintenance or related sales position. Indiana, Michigan or Ohio location preferred. Box 720 W.

DIRECTOR OF ENGINEERING

MS in EE 1938. Fifteen years responsible engineering in Government and industry. Technical direction of 400 professional men in digital computer and electromechanics. Sales and contract experience. Capable to start, build and operate engineering group. Box 721 W.

ENGINEER

BEE, over 12 years varied experience, including radar, circuits, aircraft instruments, optics, special electronic devices, supervision and report writing. Several patents. Desires creative responsible position. Box 722 W.

PATENT ATTORNEY

Electronics field, 28 years old. BSEE. (communications), LL.B. state Bar. High scholastically. About 2 year Corporate patent experience, and 4½ years engineering. Seeks position within commuting distance of New York City. Box 731 W.

ENGINEER

BSEE, MSEE 1955. ETM, Navy W.W. II. 5 years diversified experience in electronics elect. plant layout, research and development in semiconductivity, piezoelectricity. Age 27, married, family. Professor Engineering (Ohio) momentarily. Tau Beta Pi, Eta Kappa Nu, IRE, AIEE. Prefer Cleveland area. Box 732 W.

ENGINEER—INSTRUCTOR

MSc. degree 1948. Electronics major. Age 28, married. 5 years experience teaching electronics and power courses in mid-west and eastern universities. 3 years vacuum tube research. Member Sigma Xi, Eta Kappa Nu, ASEE. Navy Supply Corps experience. Desires either a teaching position or one with supervisory responsibilities in production or development. Box 733 W.

INDUSTRIAL ELECTRONIC ENGINEER

Automatic controls, HF heating, ultrasonics in 3½ years consulting, 5 years industrial development. Non-graduate, mathematical background, prec. gaging. minimum \$8000. Location mid-west. Box 734 W.

(Continued on page 148A)

electronic engineers

EE degree, most jobs minimum 3 years' experience

1. Microwave circuits
2. Circuit design
3. Electronic production design
4. Electromechanical production design
5. Field Engineers

How You Benefit from a Career

with GENERAL PRECISION LABORATORY!

You'll be taking a major step forward in your career when you join General Precision Laboratory. The reasons are many and simple:

We're a young and aggressive organization that's moving ahead fast, and you'll grow along with us . . . you'll be part of a creative staff so closely integrated that your accomplishments will be recognized quickly . . . you'll find stimulating work and a great measure of

security due to our association with a large, diversified parent organization.

Working under these conditions and living in a pleasant Westchester County community noted for its high standard of living . . . you'll have every opportunity to build a successful career.

Expenses will be paid for qualified applicants who come for interviews. Please submit complete resume to:
Mr. H. F. WARE

GENERAL PRECISION LABORATORY, INCORPORATED

A subsidiary of General Precision Equipment Corporation
63 BEDFORD ROAD, PLEASANTVILLE, NEW YORK

ELECTRONIC ENGINEERS

ADVANCE YOUR CAREER
WITH A LEADER IN WEST-
ERN ELECTRONICS

An expanding program of:

- RESEARCH • DEVELOPMENT
- PRODUCTION
- SPECIALIZED MILITARY EQUIPMENT
- ADVANCED COMMERCIAL DESIGN
- REAL CREATIVE CHALLENGE

Included are special receivers and transmitters, DF and DME, various instruments and Transistor applications—special devices, involving studies in noise, radar, miniaturization and test equipment.

Relocating expenses, good insurance plan, central location, steady advancement.

Send resume to L. D. Stearns
Engineering Employment Manager

Hoffman

LABORATORIES, INC.

3761 S. Hill St., Los Angeles,
Calif.

(Subsidiary of Hoffman Radio Corp.)



SENIOR MICROWAVE ENGINEER

Raytheon offers an outstanding opportunity for a man with the appropriate background working with ultra modern facilities at Bedford, Mass. He will supervise and direct research, development and design of microwave components and antennas for airborne radar and guided missile systems. Should have a master's degree in engineering sciences and at least 3 years experience at responsible level.

THE MISSILE AND RADAR DIVISION'S geographical location, 15 miles from Boston, provides a choice of urban or rural living, together with the finest cultural, recreational and research facilities. Fine homes available. Moving expenses paid.

Direct inquiries to

Personnel Division

RAYTHEON MANUFACTURING COMPANY

190 Willow Street, Waltham, Mass.

ENGINEERS

looking for . . .

. . . a good start?

. . . rapid development of your professional skill?

You can have both at Sperry,

PIONEERS IN A WIDE RANGE OF FIELDS, FOR MORE THAN 43 YEARS

We invite you to investigate the exceptional employment opportunities available on our unusually large research, design, and development staff, in many fields including the following:

Klystron & traveling tube research • Analogue & digital Computers • Radar • Hydraulics • Communication Equipment • Pulse Transformers • Servo Mechanisms • Electronic Circuits • Aircraft Controls • Instrumentation • Fractional H.P. Motors • Magnetic Amplifiers • Radio Frequency & Microwave Measurement.

PUBLICATIONS ENGINEERS To write manuals and engineering reports.

Advanced and challenging assignments • Association with top Engineers • Interesting, diversified work • Remuneration based on professional abilities • Modern plant—latest laboratory facilities • Adequate housing • And of course, employee benefits, and congenial surroundings, among the finest.

Please submit resume to our Engineering Personnel Section. (Personal interviews may be arranged in your city.)

SPERRY GYROSCOPE CO.

Division of the Sperry Corp.
Great Neck, Long Island, N.Y.



IMAGINATION

Got more than your share? Like to have the freedom to use it, with commensurate recognition? Then, you've come to the right ad!

That is, if you're an electronic or mechanical engineer with practical experience in the electronic industry.

We need engineers with imagination. We're growing and going . . . you're just in time to go with us. You'll enjoy the job plus the advantage of pleasant living conditions in a large, modern city . . . without the disadvantage of big city pressure.

The man to contact is Arthur E. Harrison, Vice-President of Engineering. The time is now! You'll never regret it!

wilcox

Aviation Communications and Navigation
Fourteenth & Chestnut,
Kansas City 27, Mo.

News—New Products

These manufacturers have invited PROCEEDINGS readers to write for literature and further technical information. Please mention your I.R.E. affiliation.

(Continued from page 128A)

Selenium Rectifier Handbook

The design, application, specification and circuitry of selenium rectifiers are described in comprehensive fashion in the second edition of *Federal's Selenium Rectifier Handbook*, published by the Federal Telephone and Radio Co., Clifton, N. J., a division of the International Telephone and Telegraph Corp.

This enlarged edition of 80 pages treats in detail a representative listing of the selenium rectifiers manufactured by Federal for radio and television use. It also covers rectifier designs and power-supply circuits for such applications as phonographs, audio amplifiers, amateur radios, mobile radios, photocell amplifiers, intercommunication systems and other dc power supply requirements.

In addition, servicing information for the selenium rectifier is presented in simple, easy to follow, form. Trouble-shooting tables help the serviceman or technician follow proper procedures in checking a rectifier when specific circuit conditions exist, and diagrams are provided for setting up forward and reverse current tests in the repair shop.

Available through distributors or from Federal direct, price \$.50.

(Continued on page 144A)

NEW HORIZONS

Today's horizons in electronic engineering are limited only by the vision of the individual himself. To those qualified men who desire to stand on the constantly changing frontiers of electronic development, we offer a chance to pioneer and grow with a soundly-established, yet young and progressive company.

• Electronic Field Engineers

Local and Field Assignments Available

At least 5 years' experience in any one of these fields: Servo Mechanisms; Special Weapons; Microwaves; Antennas; Circuit Design; Flight Simulators; Radio Propagation; Electronic Computers and Communications.

Qualified to instruct in the operation and supervise installation, maintenance and repair of Radar, Sonar, Flight Simulators and allied electronic equipment in the field.

Salary and advancement commensurate with ability; liberal vacation, sick leave, 9 paid holidays, group life, sickness and accident insurance plans, and a worthwhile pension system.

STAVID Engineering, Inc.

Personnel Office, 312 Park Avenue
Plainfield, N.J.—Plainfield 6-4806

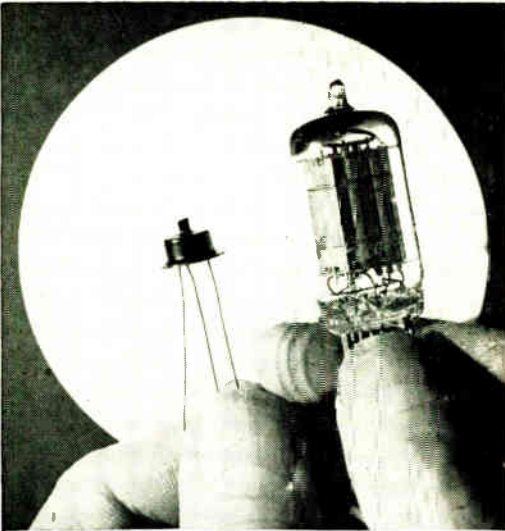

General Electric hermetically-sealed, evacuated junction transistor (left), contrasts sharply with standard miniature vacuum tube.

**GENERAL ELECTRIC
OFFERS OPPORTUNITIES TO...**

**ENGINEERS
PHYSICISTS
CHEMISTS**

WORK ON THE NEW DEVELOPMENTS IN ELECTRONICS AS AN ENGINEER WITH GENERAL ELECTRIC

Few developments today can match the importance and versatility of the tiny transistor, which has vast possibilities for both industrial and consumer use.

General Electric engineers are at work now on new improvements, new applications and advances. As always, they are aided by the finest facilities . . . by the cooperation and encouragement of recognized leaders in the field . . . by the opportunity to take on increasingly challenging assignments.

These factors, combined with stability, excellent salary and benefits, provide the engineer with the ideal environment for achievement and growth.

Experience required in the following fields:

*Advanced Development, Design, Field Service
and Technical Writing in connection with:*

**MILITARY RADIO & RADAR MULTIPLEX MICROWAVE
MOBILE COMMUNICATION COMMUNICATIONS
ELECTRONIC COMPONENTS
TELEVISION, TUBES & ANTENNAS**

Bachelor's or advanced degrees in Electrical or Mechanical Engineering, Physics, Metallurgy or Physical Chemistry and/or experience in electronics industry necessary.

Please send resume to: Dept. 5-4-P, Technical Personnel

GENERAL  ELECTRIC

ELECTRONICS PARK, SYRACUSE, N. Y.

MICROWAVE ENGINEER OR PHYSICIST

For theoretical development of wave propagation in the region of dielectric and metallic boundaries, including methods of approximation in boundary value problems, investigation of propagation through ferrites, development of specialized microwave components and application to systems. Complete digital and analogue computing facilities are available. Applicant must also be capable of directing an experimental program for verification of theoretical predictions.

MICROWAVE ENGINEER

To conduct basic experiments on microwave circuits and transmission through dielectric media, and to aid in the design of basic test equipment involving novel principles. A good understanding of electromagnetic wave phenomena is essential. Recent graduates with outstanding records will be considered.

Please send resume to:

Salary Personnel
Goodyear Aircraft Corp.
Akron 15, Ohio



Electronic Engineering Company of California

The Electronic Engineering Company of California is an independent firm engaged in the design, development and fabrication of electronic equipment for private industry and the Armed Forces. Founded and managed by electronic engineers, the Electronic Engineering Company offers a broad background of experience, highly trained personnel, excellent facilities plus a well integrated, expanding organization.

The Electronic Engineering Company has openings for engineers with experience and background in industrial and military electronics.

Please send resume of experience and education with salary requirements to:

Electronic Engineering Company of California
100 SOUTH ALVARADO STREET
LOS ANGELES - 57 - CALIFORNIA

HIGH VACUUM SYMPOSIUM

Of particular interest to individuals and organizations concerned with applications of high vacuum technology is the High Vacuum Symposium which will be held June 16, 17, and 18, 1954, at the Berkeley-Carteret Hotel at Asbury Park, N.J.

The program, comprising approximately 25 technical papers, will include discussion of Nomenclature and Standards; New Equipment and Instruments; Fundamental Developments in Vacuum Technology; Methods and Techniques; Applications and Processes. In planning the program, special care has been taken to include subjects of practical as well as theoretical importance.

Persons and organizations interested in attending the Symposium are invited to write The Committee On Vacuum Techniques, Box 1282, Boston 9, Mass.

Gilfillan Now Engaged with New Approach to Air Defense Problems

Rapidly Expanding Program Requires 5 Exceptional Men

APPLIED MATHEMATICIAN: MS. or higher degree, with some background in physics, and electronics experience on a responsible level. Capable of applying fundamental principles to unusual problems.

4 ELECTRONIC ENGINEERS: MS. or higher degree, with specific experience in systems analysis and guided missiles.

Working with Gilfillan is comparable to the best of our technological institutes, plus the satisfaction of seeing theory carried through to practical achievement.

It is this combination of academic research plus practical achievement that gives Gilfillan unique appeal to exceptional men.

If you qualify for one of the present five openings in the Gilfillan air defense program, please send a brief resume to R. E. Bell, Gilfillan Bros., 1815 Venice Blvd., Dept. 524, Los Angeles, Calif. Conference covering details will be arranged at a convenient location.



News—New Products

These manufacturers have invited PROCEEDINGS readers to write for literature and further technical information. Please mention your I.R.E. affiliation.

(Continued from page 142A)

Ford Appoints Slawson



Kenneth Slawson has been appointed Assistant to the President of Ford Instrument Co., Div. of The Sperry Corp. Mr. Slawson started with Ford in 1928. In 1946 he was appointed Manager of E. G. Staude Manufacturing, a new Sperry Corp. Division. As a result of the recent sale of Staude to the Bryant Chucking Grinder Corp., Mr. Slawson returned to Ford to his present position.

(Continued on page 146A)

Bendix Aviation Corporation

● YORK Division

This NEW division of our nationally-famous corporation has openings for . . .

ENGINEERS PHYSICISTS

Top-flight men in advanced fields of electronic research, development and product engineering are needed for challenging work under ideal conditions in our new, modern plant.

You benefit at Bendix York from our location in the heart of a beautiful suburban area, from high wages, paid vacations and holidays . . . and excellent opportunities for advancement.

Openings at all levels.

Write, Wire or Phone
Department Y-1



AVIATION CORPORATION
YORK DIVISION ●

Phone: York 5521

York, Penno.

ENGINEERS

Systems

Radar

Servo

Computer

BACKGROUND:

Responsible positions open for top level development and project engineers with practical and research experience in:

Advanced Electronic Circuits and Systems

Microwave Radar

Microwave Receivers and Transmitters

Also Engineering Design and Analysis relating to fields such as:

Analogue and Digital Computers

Servomechanisms

Communications

Navigation

Fire Control

Requirements emphasize advanced analytical and/or management experience on highly complex electronic and electro-mechanical systems.



The W.L. MAXSON Corp.
460 W. 34th ST., NEW YORK 1, N.Y.

Kindly send resume and salary requirements to:



YOUR FUTURE IN MICROWAVES

2000 5000 10,000 20,000 50,000 100,000 200,000

FREQUENCY (Megacycles/second)

ENGINEERS...E.E. — M.E.

Airtron, Inc., has pioneered in the field of microwave research and development and has become one of America's leading designers and producers of microwave relay and radar installations . . . a company with a future . . . in a field with a future.

At Airtron, Inc., you do stimulating design and development work on high frequency components in company with like-minded engineers and professional men, in a firm geared to an engineer's point of view. You work in Linden, N. J., in the Metropolitan New York area—surrounded by some of the finest suburban and country living facilities—only a short half-hour from the New Jersey shore, and the same distance from New York City.

SOME OF THE ADVANTAGES YOU GET AT AIRTRON, INC.

- A medium-sized company with a record of steady growth . . . small enough for individual recognition, but with no limitations on your achievements.
- Favorable suburban location, schools, recreation facilities, yet with all the advantages of a metropolitan location.
- Paid Hospitalization, Medical-Surgical and Life Insurance
- Annual Service Bonus • Holidays • Vacations • Pension Plan
- Active Social Program • Subsidized Tuition for Advanced Study
- Credit Union.

If you have an EE or ME degree and/or related experience in electronics or microwaves you will be interested in the opportunities for junior and senior engineers now open at Airtron, Inc.

Write or call Mr. Arthur Eckerson, Industrial Relations Department, Linden 3-3762.



1101 West Elizabeth Avenue
Linden, New Jersey

HIGHLY QUALIFIED ENGINEERS DESIRED BY DIGITAL COMPUTER LABORATORY AT MASSACHUSETTS INSTITUTE OF TECHNOLOGY

to design and develop high-speed electronic digital equipment involving vacuum-tube and magnetic-core circuitry.

Openings are also available for outstanding candidates to work on use of high-speed digital computers to control large physical systems. This involves study of control requirements of the whole system, reduction of them to a simple pattern of control instructions, and translation of the pattern into computer code. Position requires appreciation for physical systems, ingenuity, and imagination. Training in computer principles provided as necessary.

Persons from other fields wishing experience in digital computers for industrial and military uses are encouraged to apply. Positions carry opportunity for advancement. Salary appropriate to candidate's experience and training. Address:

DIGITAL COMPUTER LABORATORY, MIT, 211 Massachusetts Avenue,
Cambridge 39, Massachusetts



DEVELOPMENT ENGINEERS

FOR: Design Engineering, Practical Research, Investigations of Theories, Functional Analysis

An interesting challenge for senior design engineers to work directly with top project supervisors helping through the prototype stage new developments in:

- Automatic Control Instruments
- Airborne Armament Systems
- Electronic Navigational Aids
- Guided Missile Controls
- Magnetic Amplifiers
- Computing Equipment

For these jobs we are interested in men with two or more years experience in electro-mechanical work related to the above fields or in men with superior scholastic records in physics, electrical, electronic or mechanical engineering.

YOU'LL LIKE WORKING AT FORD INSTRUMENT

- Not too large, not too small
- Pension Plan
- Stable but progressive company
- Nine Paid Holidays
- N. Y. C. location with all its additional varied opportunities
- Two Weeks vacation with pay
- Above-average fringe benefits
- Tuition assistance for further related studies

Our policy of permanency of positions and continuity of service does not allow us to employ engineers unless there is a *clear and definite need for them projected years into the future*. And we promote from within. If you can qualify, we urge you to contact by mail, or if in N. Y. C. phone:

Mr. P. F. McCaffrey, Stillwell 4-9000, Extension 416

FORD INSTRUMENT COMPANY

Division of the Sperry Corporation

31-10 Thomson Ave., Long Island City, N. Y. (20 minutes from the heart of New York City)
VISIT OUR BOOTH NO. 533 AT THE DAYTON IRE SHOW

News—New Products

These manufacturers have invited PROCEEDINGS readers to write for literature and further technical information. Please mention your I.R.E. affiliation.

(Continued from page 144A)

New Switch

A new, precision, low loss 18-position Brown-Hill ceramic wafer-type, selector switch is now being produced by R-F Electronics, Inc., 291 N.E. 61st St., Miami, Fla.

These Brown-Hill switches have a voltage break-down of 4,000 volts ac (peak at 60 cps). They have a current carrying capacity of 30 amperes. at 60 cps, non-inductive load.

Available in 1 to 6 gangs, this switch features a new, 20-degree positive detent mechanism with adjustable stops. Its rotor blades and stator contacts are of solid pure silver, providing low resistance, high current capacity, thereby entirely eliminating receiver switching noise. The rotor contact segments do not depend on rivets to carry current. A hole and cutouts are provided in the contact for mechanical attachment of wires.

Dow-Corning-200 impregnated steatite (Grade L-5 or better), is used throughout. These switches are available either bushing or stud mounted. A life test of one million revolutions shows a minimum of wear. Additional information about the switches can be secured from the manufacturer.

(Continued on page 153A)

ENGINEERS

EE and ME

PHYSICISTS

DESIGNERS

For Work in Design & Development of:

1. Airborne navigational instruments.
2. H.F. pulse magnetic recording systems.
3. R.F., I.F., video and microwave circuits.



In the friendly Kollsman organization you'll work with intriguing problems concerning the design and development of America's finest aircraft instruments.

Please submit resumes to: Employment Manager

KOLLSMAN Instrument Corp.

80-08 45th Ave., Elmhurst, Long Island, N.Y.

MICROWAVE ENGINEERS

Minimum 3 to 5 years experience in X band and K band microwave antenna systems for precision fire control and missile radar.

Locate in New England's most beautiful state, handy to seashore, mountains, lakes . . . and metropolitan cultural advantages as well.

These are top level positions for men who wish to apply their knowledge and abilities in a company organized, owned and run by engineers, where the only limitations are the individual's ability and ambition.

If you wish such an opportunity, please send a resume to Mr. Donald Clement.

SANDERS ASSOCIATES

Nashua

New Hampshire

NORDEN

**OFFERS UNUSUAL
OPPORTUNITIES FOR
COMPETENT ENGINEERS**

**Electronic
Mechanical
Electro-Mechanical**

**FOR RESEARCH
AND DEVELOPMENT
WORK ON**

**Servo Mechanisms
Microwave Equipment
Antennas
Infrared Equipment
Communications Equipment
Computers
Gyroscopes
Radar**

- Liberal Hospitalization Plan
- Merit Salary Reviews
- Excellent Working Conditions
- Ideally located in Westchester County

•
Please telephone or send resume and salary requirements to the Personnel Department. All inquiries will be handled in confidence.

•

**THE
NORDEN LABORATORIES
CORPORATION**

**121 Westmoreland Avenue
White Plains, New York
White Plains 6-4300**

An assurance is required that the relocation of an applicant will not cause disruption of an urgent military project.

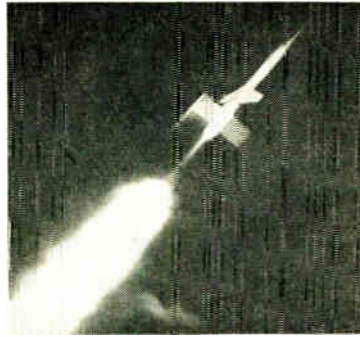

*Career-chance
of a lifetime
for*

Senior ELECTRONIC Engineers

in Lockheed's expanding Missile Systems Division

Recently formed from other Lockheed engineering organizations, the Missile Systems Division has a few openings for highly-qualified engineers in various phases of electronics.

The Division's expansion program — along with the type of work involved in its contracts — makes these openings outstanding opportunities for achievement. Engineers who qualify have probably worked on missile, radar-computer, counter-measure, IFF, AMTI or similar projects.

Lockheed has openings for:

- Senior Electronic Engineers with experience in the development, packaging, and specification of small, rugged components including resistors, capacitors and all types of magnetic parts.
- Senior Servomechanisms Engineers with circuit, auto-pilot or electro-mechanical experience (aircraft or missile experience preferred).
- Senior Electronic Design Engineers with experience in sub-miniature packaging techniques. Previous experience with potted plug-in units, etched and printed circuits is desirable.
- Senior Electronic Engineers with development and analysis experience in one or more of the following fields:



- | | |
|--|--|
| <ul style="list-style-type: none"> A. Guidance systems analysis B. Microwave antennas C. Radome design D. Microwave transmitters E. Advanced packaging techniques F. Waveguide components G. Component specification H. IF receivers and FM discriminator circuits | <ul style="list-style-type: none"> I. Synchronization and timing circuits J. Memory circuits (tubes, magnetic drums, delay lines, etc). K. High voltage power supply and CRT display circuits L. Analogue computers M. Video pulse, delay, gating, range and range rate tracking circuits |
|--|--|

In addition to outstanding career opportunities, the Missile Systems Division offers you excellent salaries commensurate with your experience, generous travel and moving allowances, an unusually wide range of employee benefits and a chance for you and your family to enjoy life in Southern California.

Coupon below is for your convenience.



L. R. Osgood Dept. IRE-M-5
LOCKHEED MISSILE SYSTEMS DIVISION
7701 Woodley Avenue, Van Nuys, California

Dear Sir: Please send me information on the Missile Systems Division.

name
field of engineering
street address
city and state

WHITE-RODGERS ELECTRIC CO.

ARMAMENT
ENGINEERING
DIVISION

NEEDS
ENGINEERS

for
RESEARCH,
DESIGN,
DEVELOPMENT

of
MISSILE GUIDANCE SYSTEMS
AUTOMATIC FLIGHT FORMATION
SYSTEMS and ASSOCIATED COMPONENTS

To formulate dynamics and computer equations,
and to design and develop experimentally
electro-mechanical computers and instrument
servo-mechanisms

SEND RESUME TO EMPLOYMENT MANAGER
1201 CASS AVE. ST. LOUIS 6, MO.

MAN WHO CAN CREATE A STRONG ELECTRONICS DEPT.

Missile manufacturer having large mechanical design staff but small electronics group is seeking a man capable of creating and heading an expanding electronics department. Will be responsible for design of electronic systems which are optimum for a given missile, and the choice, coordination, and packaging of component equipment. Salary range \$10,000 to \$15,000 per year.

Please send resume of background including a snapshot and details of related experience to Box 771.

INSTITUTE OF
RADIO ENGINEERS

1 East 79 St., New York 21, N.Y.

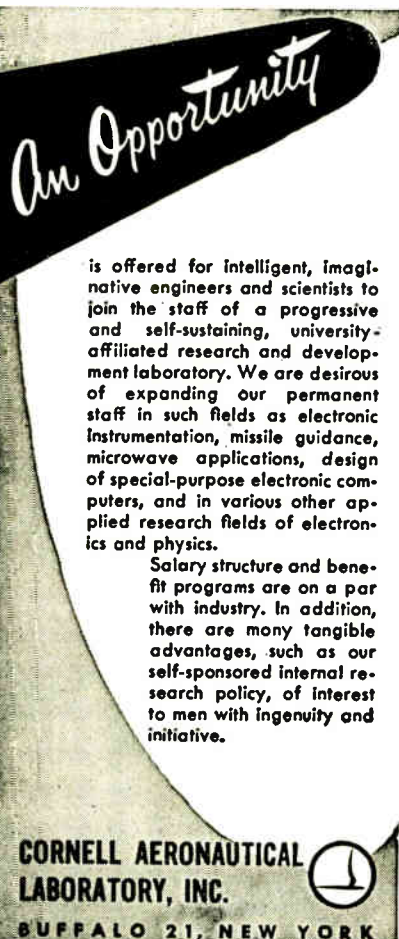

is offered for intelligent, imaginative engineers and scientists to join the staff of a progressive and self-sustaining, university-affiliated research and development laboratory. We are desirous of expanding our permanent staff in such fields as electronic instrumentation, missile guidance, microwave applications, design of special-purpose electronic computers, and in various other applied research fields of electronics and physics.

Salary structure and benefit programs are on a par with industry. In addition, there are many tangible advantages, such as our self-sponsored internal research policy, of interest to men with ingenuity and initiative.

**CORNELL AERONAUTICAL
LABORATORY, INC.**

BUFFALO 21, NEW YORK

Positions Wanted

(Continued from page 140A)

DIGITAL COMPUTER ENGINEER

Five years experience; logical design, component development, input-output equipment, system testing; present on supervisory staff of general purpose machine; seeking affiliation with group requiring above experience in high level position. Box 737 W.

MATHEMATICAL STATISTICIAN

Strictly non-military work wanted by man with excellent background in evaluation of military electronic systems such as radar, missile guidance, radio-location, fire control. Well qualified in error analysis, statistical planning of experiments and related publications work. Box 738 W.

SERVO & COMPUTER ENGINEER

BS. in physics, near MS. in E.E. Over 6 years heavy experience in design, development and production. Additional experience in teaching and sales. Now working on servo systems and analog computer design for guidance systems. Metropolitan New York area preferred. Available June 1954. Box 745 W.

SYSTEMS ENGINEER

BEE., MEE., age 29, married, 2 children. 6 years experience development of electronic circuits, digital pulse techniques, servo data transmissions and fire control systems. Presently group leader. Desires challenging position with some administrative capacity in electromechanical field. Box 746 W.

PHYSICIST—ENGINEER

B.Sc. degree in physics and mathematics. 4 years war time experience in radar, 5 years post-graduate experience in nuclear instrumentation and electronic engineering. Age 32, married, 2 children. Desires position in research or development, preferably in eastern Canada. Box 747 W.

ENGINEER

BSEE 1950, age 33, married, 2 children. Product development laboratory of large electronic company 2½ years. Circuit design for testing experimental tubes. Past year on management staff. Coordinated Standards Program of diversified activities. Supervised contact with industrial organizations. Desires permanent position in administrative capacity. Long Island area preferred. Box 748 W.

ENGINEER

SBEE., SMEE. 1952. Listens, thinks, does. Experienced pulse circuits, electron optics, network design, color television, air navigation systems. Prefers color television or antenna. Boston, Mass. area preferred. Box 749 W.

ENGINEER

BSEE. Age 25, Single. Desires position in Europe. Fluent speaking, reading and writing knowledge of the Italian language. Box 750 W.

PATENT ATTORNEY

Capable of preparing and prosecuting patent applications with minimum of supervision. 3 years experience electronic, electrical and electro-mechanical cases through appeals and interferences. Wish to locate within about 100 miles of New York City. Box 751 W.

ENGINEER

BS in Radio Engineering 1943. Experienced in communication, industrial electronics and radar. Have supervisory and creative abilities. At present employed as a Field Engineer in the Arctic. Age 31, single. Wish to work in any of the Latin American countries. Box 735 W.

ENGINEERS

Republic Aviation

Expanding

Guided Missiles Division

Here is a unique opportunity for growth in today's fastest growing field for engineers with aircraft, missiles or related experience. Our Guided Missiles Division is forging ahead with new, important Government contracts.

Responsible positions are open for:

- Electronics Engineers**
- Servo Engineers**
- Aerodynamicists**
- Electromechanical Designers**
- Instrument Engineers**
- Analogue Computer Engineers**
- Flutter Engineers**
- Stress Engineers**
- Operations Research Engineers**

CHIEF TECHNICAL ENGINEER

Responsible for administration of departments assigned to him and technically able to evaluate existing missile systems, conceive new systems, and supervise development of complete systems, as well as testing of systems. Must primarily possess extensive technical knowledge and experience in fields of Electronics and Servo-Mechanisms. Also required is broad experience in over-all missile systems and knowledge of state of the art, especially as related to sections of engineering for which he is responsible.

Please forward complete resume to attention of Mr. E. Eddy

**Guided Missiles Division
99 Church Street
New York 7, New York**

REPUBLIC
AVIATION CORPORATION

Career-chance of a lifetime
for

Research Engineers



Your career can go up
*with Lockheed's expanding
Missile Systems Division*

- Recently formed from other Lockheed engineering organizations to prepare for the era of automatic flight, the Missile Systems Division offers a few Research Engineers the career opportunity of a lifetime.
- For Research engineers of ability, experience and initiative, this is an unparalleled opportunity for advancement and achievement.
- The positions now open call for experience in airborne weapons systems problems such as: weapons design, system evaluation, guidance methods, sub-system requirements and operational problems.
- In addition to outstanding career opportunities, the Lockheed Missile Systems Division offers you excellent salaries commensurate with your experience, generous travel and moving allowances, and a better life for you and your family in Southern California.

■ **Coupon below is for your convenience.**

.....
Mr. L. R. Osgood Dept. IRE-MRE-5
LOCKHEED MISSILE SYSTEMS DIVISION
7701 Woodley Avenue, Van Nuys, California

Dear Sir: Please send me information on the Missile Systems Division.

my name

my field of engineering

my street address

my city and state

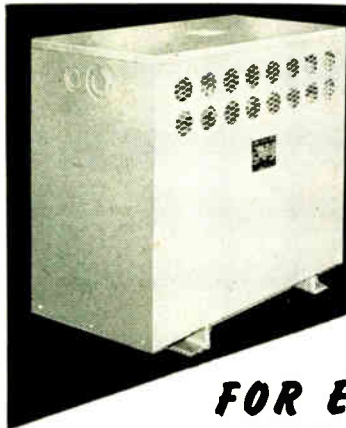

LARGE TRANSFORMERS

FOR ELECTRONIC APPLICATIONS

For electronic applications requiring special or experimental transformers of large capacity Acme Electric can supply custom-built units designed to exact electrical characteristics and performance requirements.

We invite your inquiry.

ACME ELECTRIC CORPORATION
Main Plant: 445 Water Street • Cuba, N.Y.

West Coast Engineering Laboratories: 1375 W. Jefferson Blvd., Los Angeles, Cal.
In Canada: ACME ELECTRIC CORP. LTD. • 50 Northline Rd. • Toronto, Ont.



Acme  **Electric**
TRANSFORMERS

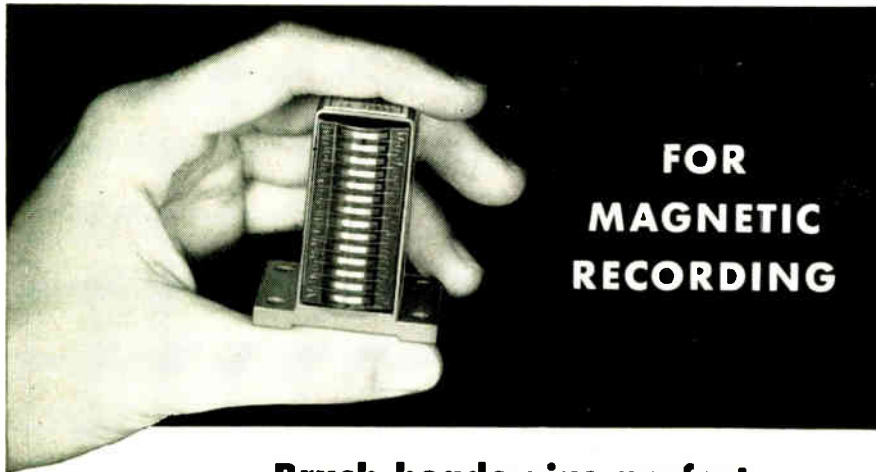

FOR MAGNETIC RECORDING

Brush heads give perfect time-phase accuracy

This Brush multi-channel magnetic head (Model BK-1500 series) features precision gap alignment. When you use tape recorders incorporating these heads, you can record data on one machine, and play back on another—with all signals remaining in perfect time-phase relationship. As many as

14 tracks can be recorded on a single tape 1¾ inches wide.

Brush produces a complete line of magnetic recording heads, with models available for all existing applications. For complete information, write Brush Electronics Company, Dept. F-5, 3405 Perkins Avenue, Cleveland 14, Ohio.

BRUSH ELECTRONICS

INDUSTRIAL AND RESEARCH INSTRUMENTS
PIEZO-ELECTRIC MATERIALS • ACOUSTIC DEVICES
MAGNETIC RECORDING EQUIPMENT
ULTRASONIC EQUIPMENT



COMPANY

formerly
The Brush Development Co.
Brush Electronics Company
is an operating unit of
Clevite Corporation.



(Continued from page 127A)

- Dempsey, M. E., 535 Cleveland Rd., Linthicum Heights, Md.
Derda, J. A., 1713 Bank St., Baltimore 31, Md.
DeRosa, G. D., 2801 Mocking Bird La., Midwest City, Okla.
D'Evelyn, R. P., U.S.S. Hazelwood, c/o FPO, San Francisco, Calif.
Diebold, J. T., Reinhold Publishing Co., 330 W. 42 St., New York, N. Y.
Doctor, D. E., Bell Telephone Laboratories, Inc., Whippany, N. J.
Doll, C. L., 8012 State St., Ralston, Nebr.
Douglas, J. E., 7003 Housman St., Houston, Tex.
Drake, E. S., 117 Highview St., Mamoroneck, N. Y.
Duerig, W. H., Electro Mechanical Research, Inc., Ridgefield, Conn.
Dula, A. M., 505 E. Westmoreland Rd., Falls Church, Va.
Durnell, R. S., 201 Euclid Ave., Haddonfield, N. J.
Dyal, J. O., Jr., Dahlgren, Va.
Ennis, F. J., 1010 Garfield Ave., Palmyra, N. J.
Ernst, C. E., 4918 Laurene St., Flint 5, Mich.
Eromann, R. G., 41 Eldridge Gardens, W. Collingswood, N. J.
Evans, R. C., Box 123, Stewart AFB, Newburgh, N. Y.
Fearman, E. L., 3127 Highview Ave., Altadena, Calif.
Feldner, L., 5247½ Carson, Long Beach, Calif.
Fenton, A. P., Box 421, San Leandro, Calif.
Finneran, R. J., 7521 Maple Ave., Takoma Park, Md.
Flood, J. L., 18 W. William St., Bath, N. Y.
Forrer, M. P., 41 S. Burnet St., East Orange, N. J.
Franklin, P. E., 8626—50 St., S., Seattle 8, Wash.
Fraustro, B., 120 Babcock St., Melbourne, Fla.
Freidner, G. E., 590 Buffalo St., Conneaut, Ohio
Fuqua, S. W., 372 Kenilworth Ave., Dayton 5, Ohio
Galavan, T. P., 185 W. Norman Ave., Arcadia, Calif.
Garabedian, H. B., 254 C Garfield Ave., Collingswood 7, N. J.
Garthwaite, J. L., 62 Parkhill Ave., Staten Island 4, N. Y.
Gartman, A. R., 10414 Bramard Dr., Parma 30, Ohio
Gebhard, R. F., A.M.R.L., Fort Knox, Ky.
Geismar, G. G., 99-05—63 Dr., Rego Park, L. I., N. Y.
Georgi, E. A., Jr., Chestnut Hill Rd., Norwalk, Conn.
Gerlach, R. K., 227A Princeton Rd., Haddonfield, N. J.
Gibson, J. J., Huskvarnavagen 122, Vattersnas, Sweden
Gilmore, E. H., 2nd AACs 1 M Sqdn., APO 942, c/o Postmaster, Seattle, Wash.
Gloates, E., c/o Beekman, 5 E. Washington Ave., Bath, N. Y.
Godawski, T. J., 5035 W. Henderson, Chicago 41, Ill.
Gonzales, W., 5105—217 St., Bayside 64, L. I., N. Y.
Grabbe, E. M., Ramo-Wooldridge Co., 6620 Belanca Ave., Los Angeles 45, Calif.
Gray, R. K., 28 Bellevue Ter., Collingswood 7, N. J.
Gray, R. L., Jr., 209 S. Sproul Rd., Broomall, Pa.
Gross, J. I., 155 Hansbury Ave., Newark 8, N. J.
Gunn, D. L., 828 S. Fairfield Ave., Lombard, Ill.
Gyllenhaal, P. R., Woodland Rd., Bryn Athyn, Pa.
Hamlin, W. O., R.F.D. 2, Emporium, Pa.
Happ, W. W., Electronics Division, Sylvania Electric Products, Inc., Ipswich, Mass.
Harris, C. F., 111 E. Rische, San Antonio 4, Tex.
Harrison, H. W., 3999 McKenzie Ave., Mt. View, Calif.
Hartnett, J. D., 113 Osborn Rd., Aberdeen, Md.

(Continued on page 151A)



(Continued from page 150A)

- Hayes, P. J., RCA International Division, 30 Rockefeller Plaza, New York 20, N. Y.
 Henkel, G. F., 3958 W. 157 St., Cleveland 11, Ohio
 Herscher, M. B., 5832 Pemberton St., Philadelphia 43, Pa.
 Hicks, F. M., Box 599, Houston 1, Tex.
 Hinrichs, C. A., Dir. Comm., Hq. NEAC, APO 62, c/o Postmaster, New York, N. Y.
 Hoffer, L., 218-27 Grand Central Pkwy., Queens Village, L. I., N. Y.
 Holley, J. S., 7 Poinsetta St., Middletown, Conn.
 Holmes, D. D., 1636 Balmoral, Chicago 40, Ill.
 Hrivnak, A., 209 Perry St., Saginaw, Mich.
 Humphries, J. H., 1812 Baltic Ave., Virginia Beach, Va.
 Hunt, C. J., 7442 Carrothers, Houston 16, Tex.
 Inch, H. E., 110 E. Bowman, Edmond, Okla.
 Jackson, D. E., 28 Greenwood Pl., Valley Stream, L. I., N. Y.
 Jackson, T. R., 1451 E. Maple Rd., Birmingham, Mich.
 Jaenke, M. G., 308 Arnold La., Alamogordo, N. Mex.
 Jestice, A. L., Lowry AFB, Denver, Colo.
 Johnston, R. W., 1808 Roszel Ave., Royal Oak, Mich.
 Jones, R. T., 520 Dinwiddie St., Apt. 7, Norfolk 6, Va.
 Jones, W. H., Brooks Place, Baldwinsville, N. Y.
 Joyce, F. C., Jr., 329 Louisa St., Williamsport, Pa.
 Kaufman, A. R., 2021 Delwood Dr., R.F.D. 12, Fort Wayne 12, Ind.
 Kay, J. P., Kay Sales Co., 3760 Broadway, Kansas City 11, Mo.
 Keefe, J. R., Jr., 306 Ohio St., Huron, Ohio
 Keeley, J. F., 41 Hooker Ave., Poughkeepsie, N. Y.
 Kenrich, C. M., 590 N. "P" St., Livermore, Calif.
 Kessler, J. C., Robertdale Rd., R.F.D. 2, Bedford, Ohio
 Kiel, J. H., Box 621, New York 1, N. Y.
 Klein, G. H., 312 Beechwood Rd., Ridgewood, N. Y.
 Kluver, J. W., 120 E. 31 St., New York, N. Y.
 Koppenhaver, J. T., 32 W. Cedar Ave., Merchantville 8, N. J.
 Ladenson, M., 624 Osage Ave., Philadelphia 43, Pa.
 Lambert, L. W., R.F.D. 2, Poynette, Wis.
 Lander, R. F., 6903 Quakertown Ave., Canoga Park, Calif.
 Langelo, V. A., 209 Greenwood Ave., Mt. Holly, N. J.
 Langton, B. W., 48 Sheridan St., Brantford, Ont., Canada
 Langwell, J. F., 4531 Lomitas, Houston, Tex.
 Lieberman, D., 1732 Monroe Ave., New York 57, N. Y.
 Lilly, C. H., 2142B S. John Russell Cir., Elkins Park, Pa.
 Lovitt, S. A., 1504 Montana St., El Paso, Tex.
 Lungo, A., 7219 Colgate Ave., Cleveland 2, Ohio
 Lynch, D. F., Jr., 270 Park Ave., Yonkers, N. Y.
 Lyons, L. J., 5817 Alviso Ave., Los Angeles 43, Calif.
 Maciag, E. T., 4088 W. 48 St., Cleveland, Ohio
 MacKenzie, R. P., 35-44-75 St., Apt. 5F, Jackson Heights 72, L. I., N. Y.
 Maher, E. F., 17 Cornell Ave., Brookhaven National Laboratory, Upton, L. I., N. Y.
 Mahoney, T. J., Jr., 3323-71 St., Jackson Heights 72, L. I., N. Y.
 Manetsch, T. J., 219 Girard, S.E., Albuquerque, N. Mex.
 Mann, H., 141-11-78 Rd., Flushing, L. I., N. Y.
 Mannik, G., 412 William, Boonton, N. J.
 Marshall, D. F., 1006-26 St., Huntington, W. Va.
 Martin, H. F., 20 Hensley Ave., San Jose 12, Calif.
 Martin, P. T., 66-03-52 Ave., Maspeth 78, L. I., N. Y.
 Masterson, J. P., D/Eng. Hq. AACCS, Andrews AFB, Washington 25, D. C.

(Continued on page 152A)

NEW

PHASE DETECTOR 0.1° ACCURACY 10 KC to 10 MC

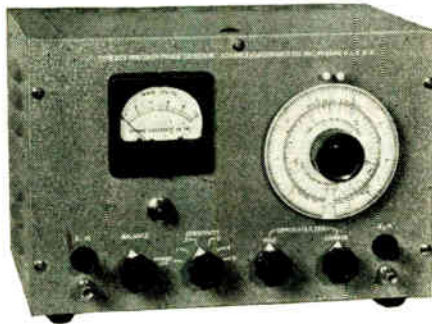

TYPE 205

Type 205 Phase Detector was developed to meet the increasing need for detecting phase angle with error of less than 0.1 degrees in high frequency communications systems such as color television.

PRICE \$445

SPECIFICATIONS

ACCURACY: ± 0.1 degree in phase reading or $\pm 1\%$ of the time delay indicated on the dial of the continuously variable delay line.

RESOLUTION TIME: 5×10^{-10} seconds or smaller; the smallest phase angle can be read on the dial is approximately equal to $5 \times 10^{-10} \times 360 \times$ frequency in degrees.

TIME DELAY: Three continuously variable delay lines are supplied with the unit, 0 to 0.45 microsecond, 0 to 0.25 microsecond and 0 to 0.05 microsecond.

PHASE RANGE: The maximum phase range is equal to the total time delay of the continuously variable delay line multiplied by the frequency of the signals and 360.

INDICATOR SENSITIVITY: Approximately 0.02 volts full scale maximum.

INPUT IMPEDANCE: Two low capacity probes with input capacitance less than 4 mmf are supplied with the unit. The panel binding posts have about 1 megohm shunted with 12 mmf on both input channels.

CONTINUOUSLY VARIABLE TIME DELAY PASSIVE NETWORK with 5×10^{-10} SEC. RESOLUTION TIME

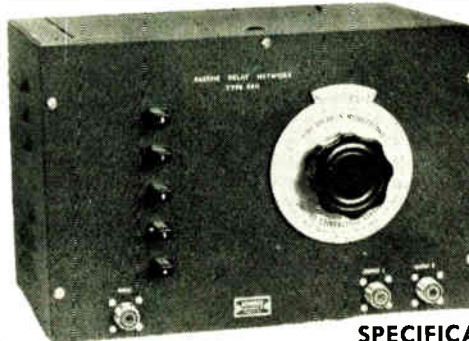

TYPE 2011

Type 2011 is well suited for variable time delay for pulses, phase angle measurement, or time measurement of various signals.

- Faithful reproduction of the wave form of the input signal.
- No time jitter.
- No limit on repetition rate.
- Millimicrosecond accuracy.

PRICE \$245

SPECIFICATIONS

TIME DELAY: Continuously variable from 0 to 11 microseconds.

RESOLUTION TIME: Less than 5×10^{-10} seconds from 0 up to 11 microseconds.

BANDWIDTH: 10 cps to 15 megacycles when the step variable delay line is at its off position (time delay from 0 cps to 0.5 usec), otherwise, the upper limit decreases to 3.3 megacycles.

RISE TIME: Less than 10% of the time delay at any point.

INPUT IMPEDANCE: 20 uuf shunted with 1 megohm direct.

OUTPUT IMPEDANCE: 300 ohms nominal.
ACCURACY OF TIME DELAY: Maximum error less than 10^{-3} second or 0.1% of the time delay at any point with correction curve, otherwise, one percent of the time delay at any point.

WRITE FOR DATA

ADVANCE ELECTRONICS CO.

451 HIGHLAND AVE.

PASSAIC, N.J.

High Voltage Resistors Now specified for COLOR TV

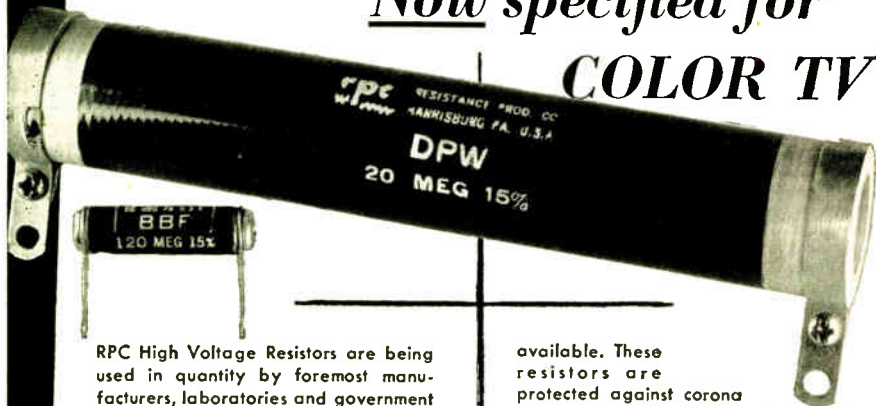

RPC High Voltage Resistors are being used in quantity by foremost manufacturers, laboratories and government agencies where stable dependable resistors are required. These resistors are now being specified for color TV. Special designs available where spacing requirements or corona presents a problem.

Type B High Voltage Resistors can be furnished in values to 100,000 megohms. Standard tolerance is 15%. Closer tolerances

available. These resistors are protected against corona and mechanical damage by a high dielectric plastic jacket. They are readily mounted and can easily be assembled to make tapped resistors. Lengths from 1" to 6 1/2". Voltage ratings to 40 KV. Power ratings up to 10 watts.

Type D High Voltage Resistors are larger tubular units and are available for voltages to 125 KV. Power ratings up to 90 watts. Sizes to 18 1/2" long. Available with lug or ferrule terminals.



RESISTANCE PRODUCTS CO.
714 RACE STREET HARRISBURG, PENNA.

Makers of Resistors—High Megohm, High Voltage, High Frequency, Precision Wire Wound



(Continued from page 151A)

- McCarter, E. R., 65 E. 53 St., Tulsa 5, Okla.
 McCartney, E., 2 Winding Rd., Rockville Centre, L. I., N. Y.
 McKnight, C. J., c/o The American Legation, Tangier, Morocco
 McMillen, R. C., 200 W. Pembrey Dr., Wilmington, Del.
 McNamara, W. E., 51 Lowell St., Somerville 43, Mass.
 McSorley, S. L., Box 287, Wayne, Pa.
 Meo, M., 22 Central Ave., Newark, N. J.
 Merda, W. R., Box 785, R.F.D. 1, West Chicago, Ill.
 Metzger, E. E., 9766 TSU, Camp Detrick, Frederick, Md.
 Miele, A. A., RCA, David Sarnoff Research Center, Princeton, N. J.
 Miles, M. W., 5408 Belle Vista, Baltimore 6, Md.
 Miller, R. T., 286 Seminole Dr., Eau Gallie, Fla.
 Monk, J. D., 601 E. Third St., Dayton 2, Ohio
 Montalbano, M., Box 16, Malibu, Calif.
 Moore, J. E., 5684 Gross Dr., Dayton, Ohio
 Moran, J. A., Jr., Phelps-Dodge Copper Products Corp., Point St., Yonkers 1, N. Y.
 Morenz, P. W., 4802 N. Earle, Rosemead, Calif.
 Morison, C. T., 208 Adclare Ct., Rockville, Md.
 Morris, G. H., 7968 Matilija, Van Nuys, Calif.
 Mosher, F. M., 140 Glen Albert Dr., Toronto 16, Ont., Canada
 Mozek, G. G., 932 McBride Ave., West Paterson, N. J.
 Muirhede, J. C., 2015 Blake Ave., Dayton 4, Ohio
 Murphy, T. R., 7319 Raton, Houston, Tex.
 Muroff, J. M., 3401 Powelton Ave., Philadelphia 4, Pa.
 Nair, B. K. S., I.N.S. Delhi, c/o Fleet Mail Office, Bombay, India
 Neibich, T. J., 226 W. Manheim, Philadelphia 44, Pa.
 Nelson, W. E., 1806 N. Paulina, Chicago, Ill.
 Neubert, W. E., 21 Highlawn Dr., Pittsfield, Mass.
 Newhall, E., Sylvania Electric Products, Inc., Ipswich, Mass.
 North, G. R., 814 Broadway-Stevens Bldg., Camden 2, N. J.
 O'Brien, J. F., Jr., 1207 Wakefield Rd., Flourtown, Pa.
 Oke, D. M. T., 8 Agbomalu Ct., Lagos, Nigeria, West Africa
 Onysyk, J., 1002 Wexford Ave., Cleveland 9, Ohio
 Overmier, C. S., 138 W. 78 St., Los Angeles 3, Calif.
 Page, D. F., Center, St. Forbes P.O., Ottawa, Ont., Canada
 Parks, W. B., 129 Louie, Lake Charles, La.
 Parsons, R. W., 8026 Flintridge Dr., Houston 16, Tex.
 Pearce, R. G., 589 Rhodes Ave., Toronto 8, Ont., Canada
 Pecot, V. D., 2222 Kipling St., Apt. 2F, Houston, Tex.
 Penton, R. E., 2096 Claremont Ave., Apt. 22, N.D.G., Montreal, Que., Canada
 Peterson, R. K., 134 Alexander Hamilton Dr., San Antonio, Tex.
 Phillips, G. W., 717 Biggs St., Laurinburg, N. C.
 Pike, G. W., 55 Randolph Pl., South Orange, N.J.
 Podlesny, R. F., 271-03—77 Rd., New Hyde Park, L. I., N. Y.
 Pope, R. H., 915 Cedar La., Tullahoma, Tenn.
 Power, J. B., 25 Van Duyn Dr., Trenton 8, N. J.
 Procop, L. W., 354 Pin Oak La., Westbury, L. I., N. Y.
 Pryzdial, E. F., 780 Palmerston Ave., Toronto, Ont., Canada
 Pulaski, M. E., Clevite Brush Development Co., 3405 Perkins Ave., Cleveland 3, Ohio
 Ramaswamy, S., 135 Town Planning Area, Tirupathi P.O., Andhra State, South India
 Ramler, D. A., 32 Alberta Rd., Brookline 67, Mass.
 Reed, R. E., 536 W. James St., Lancaster, Pa.
 (Continued on page 154A)

SWITCHCRAFT NEW TELEVER SWITCH

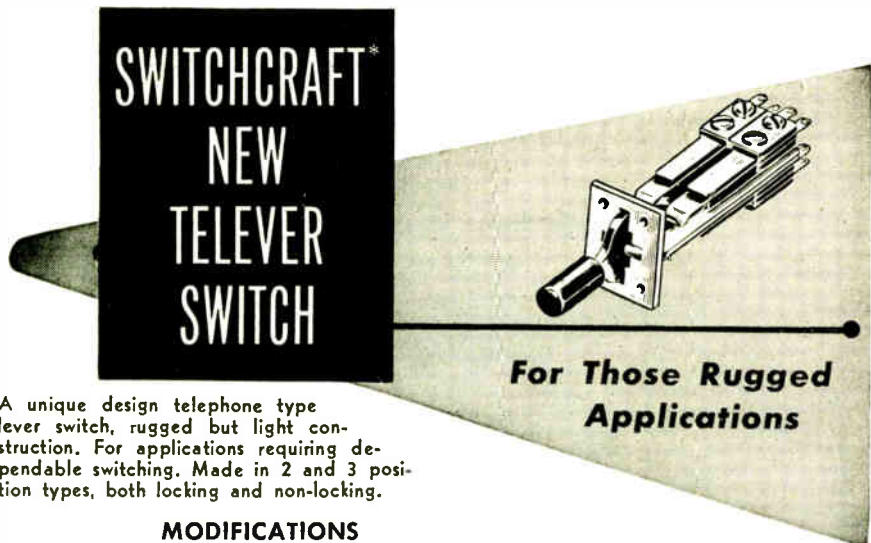

For Those Rugged Applications

A unique design telephone type lever switch, rugged but light construction. For applications requiring dependable switching. Made in 2 and 3 position types, both locking and non-locking.

MODIFICATIONS

Our flexible tools make modifications to meet special requirements economical and practical.

Write for catalog of standard switches and other components. For modifications please furnish complete information—applicable specifications, quantities, etc., for prompt handling of your inquiry.

SWITCHCRAFT
INC.

1332 N. Halsted St., Chicago 22, Ill.

Canadian Rep.: Atlas Radio Corp. Ltd., 560 King St. W. Toronto 2B, Canada. Phone: Waverly 4761

*The name "Switchcraft" is a registered trade mark and is the property of Switchcraft, Inc.

"Lev-R-Switch"



A smaller switch for single hole mounting. Many exclusive features that make this switch outstanding. Available in many popular and less complex circuits. Write.

AVAILABLE AT ALL LEADING RADIO PARTS JOBBERS

PROFESSIONAL ENGINEERING CARDS

ALFRED W. BARBER LABORATORIES

Specializing in the Communications Field and
in Laboratory Equipment
Offices, Laboratory and Model Shop at:
32-44 Francis Lewis Blvd., Flushing, L.I., N.Y.
Telephone: Independence 3-3306

Edward J. Content, P.E. and Staff INTERNATIONAL RADIO CONSULTANTS

Pan American Radio Tangier Int'l Zone
Bldg., 16 Rue Delacroix Morocco
Specialized in the design, construction,
foreign, Electronic, projects, and advising
governments at Int'l Telecommunications
Union.

CROSBY LABORATORIES, INC.

MURRAY G. CROSBY & STAFF
RADIO-ELECTRONIC RESEARCH
DEVELOPMENT & ENGINEERING
COMMUNICATIONS, FM & TV
ROBBINS LANE
HICKSVILLE, NEW YORK
HICKSVILLE 3-3191

INTERFERENCE MEASUREMENT SERVICES

OF
DYNAMIC ELECTRONICS—N.Y., INC.
Director—H. S. BENNETT, DR. ENG., P.E.
Specialists in determining equipment
compliance with government
radio interference
specifications.
73-39 WOODHAVEN BLVD.
GLENDALE, L.I. IL-9-7000

ELDICO OF NEW YORK, INC.

Donald J. S. Merten and Engineering Staff
Consultants on Interference Elimination
from Transmitters, Induction Heaters,
Diathermy, etc.
44-31 Douglaston Parkway, Douglaston, L.I., N.Y.
Bayside 9-8686

Richard B. Schulz *Electro-Search*

Radio-Interference Reduction;
Development of
Interference-Free Equipment,
Filters, Shielded Rooms
4337 N. 5th Street, Philadelphia 40, Pa.
GLadstone 5-5353

ELK ELECTRONIC LABORATORIES, INC.

Jack Rosenbaum
Specializing in design and development of
Test Equipment for the communications,
radar and allied fields
333 West 52nd St., New York 19, PL-7-0520

FREDERICK RESEARCH CORP.

BETHESDA 14, MARYLAND
Carl L. Frederick, D.Sc., Pres.
Tel: Washington, D.C., OLiver 4-3229
Research, Specifications, Development, Engi-
neering, Manufacture, Technical Writing, Off-
set Printing—Fields of Test Equipment, Radio
Interference, Tuners, Circuits, Electromechanical
Systems, Components.

PAUL GODLEY CO.

Consulting Radio Engineers
P.O. Box J, Upper Montclair, N.J.
Offs & Lab.: Great Notch, N.J.
Phone: Montclair 3-3000
Established 1926

GOVERNMENT CONTRACT LIAISON AND CONSULTANTS

GORDON ASSOCIATES, INC.

Specializing in Signal Corps Electronic Require-
ments, Technical Manuals, Tabular List of
Parts, Drawings
L. Gordon, Pres. P. Treston, Ch. Engr.
157 Broad Street Telephone
Red Bank, New Jersey Red Bank 6-2743

HALLER, RAYMOND AND BROWN, INC.

Engineering Analysis
Operations Research
Electronic Development
State College, Pennsylvania, Phone 7611

HOGAN LABORATORIES, INC.

John V. L. Hogan, Pres.
APPLIED RESEARCH, DEVELOPMENT,
ENGINEERING
Est. 1929. Electronics, Optics, Mechanisms,
Facsimile Communication, Digital Computers,
Electro-sensitive recording media, Instrumenta-
tion.
155 Perry Street, New York 14 CHelsea 2-7855

LEONARD R. KAHN

Consultant in Communications and Electronics
Single-Sideband and Frequency-Shift Systems
Diversity Reception - Modulation Theory
Applications of Magnetic Tape Recording
Elizabeth Bldg., 22 Pine St., Freeport, L.I., N.Y.
Freeport 9-8800

McKAY ELECTRIC CO.

Research and Manufacturing
Engineers
James R. Walker M. H. McKay
Specialists in Magnetic Servo
Amplifiers and Regulators
19790 Stahelin Ave.
Detroit 19, Mich.

L. J. CASTRIOTA M. WIND
S. W. ROSENTHAL P. G. MARIOTTI

Microwave Consultants

Radio Frequency and Microwave Components
Cable—Waveguide—Coax
Telephone G.P.O. Box 844
BOulevard 3-2096 Brooklyn 1, N.Y.

Microwave Development Laboratories Inc.

Henry J. Riblet, Pres.
Design, Development and Fabrication
of Waveguide Components
Waltham 5-6708 220 Grove Street
Waltham 5-7725 Waltham, Mass.

E. V. NAYBOR

Consultant on Electro-Magnetic Devices
Relays, Solenoids, Actuators and
Associated Equipment
Design-Development-Prototypes
Test Equipment
30 Manorhaven Blvd., PO. 7-2676
Port Washington, N.Y.

EVERT M. OSTLUND

Consulting Radio Engineer
Radio—Microwave
Communication—Control
Systems and Equipment
Planning, Research, Development
ANDOVER, NEW JERSEY
Tel: Lake Mohawk 8635

PICKARD AND BURNS, INC.

Consulting Electronic Engineers
Analysis and Evaluation of Radio Systems
Research, Development, Design and Production
of Special Electronic Equipment and Antennas.
240 Highland Ave. Needham 94, Mass.

Paul Rosenberg Associates

Consulting Physicists
100 STEVENS AVE. • MOUNT VERNON, NEW YORK
CABLE: PHYSICIST MOUNT VERNON 7-8040

TELREX, INC.

M. D. Ercolino, Pres.
H. F. ANTENNA SPECIALISTS
Communication Arrays
Reception or Transmission
For FM, TV, and Amateur Service.
Asbury Park, N.J.—Phone AP 2-7252

WHEELER LABORATORIES, INC.

Radio and Electronics
Consulting — Research — Development
R-F Circuits — Lines — Antennas
Microwave Components—Test Equipment
Harold A. Wheeler and Engineering Staff
Great Neck, N.Y. HUNter 2-7876

News—New Products

These manufacturers have invited PROCEEDINGS
readers to write for literature and further technical
information. Please mention your I.R.E. affiliation.

(Continued from page 146A)

New Helipot Plant



Helipot Corp., precision potentiometer
manufacturer, opened a new eastern plant
in Mountainside, N. J. on December 3.
Helipot, with headquarters in South Pasa-
dena, Calif., is a division of Beckman In-
struments, Inc.

IF Transformer



J. W. Miller Co., 5917 S. Main
St., Los Angeles 3, Calif., is pro-
ducing subminiature k-tran IF
transformers under a patent ar-
rangement with Automatic Mfg.
Corp.

The component supplies 455 kc.
Through the use of a ferrite shell core
material, these sub-miniatures claim the
gain and bandwidth characteristics pre-
viously obtained in larger assemblies. Di-
mensions $\frac{1}{2}$ inch square \times $1\frac{1}{2}$ inches high.
Price \$2.50.

(Continued on page 159A)

Microwave Assemblies, Radar Components, and Precision Instruments . . . manufactured to your Blueprints and Specifications.

N.R.K. MFG. & ENGINEERING CO.
4601 WEST ADDISON STREET • CHICAGO 41, ILL. • SPRing 7-2970



(Continued from page 152A)

- Reis, C. S., 194 Sylvan Ave., San Bruno, Calif.
 Reilly, E. J., 1589 Woodhurst Rd., Mayfield Heights 24, Ohio
 Ricketts, J. B., Burroughs Co., Paoli, Pa.
 Roberts, F. R., 2200 Third St., Coleston, Norristown, Pa.
 Robinson, F. F., 111 Broadway, New York 6, N. Y.
 Roess, T. L., 47 Lincoln Blvd., Kenmore 17, N. Y.
 Roka, E. G., 500 Washington Ave., Hopkins, Minn.
 Rosen, B. H., 29 Twin Leaf, Levittown, Pa.
 Rosenberg, A., Box 264, Little Falls, N. J.
 Ross, A., Box 3655, Carmel, Calif.
 Roth, J. F., 4610-31 Rd., S., Arlington, Va.
 Rupp, V. T., 2230 W. 11 St., Los Angeles 6, Calif.
 Ruscus, P. V., 141 Jacques St., Elizabeth 4, N. J.
 Ryan, C. C., Westinghouse Electric Corp., Baltimore, Md.
 Sandoval, J., 108½ Atlantic Ave., Long Branch, N. J.
 Sanford, E. E., 33 Village Rd., Clifton, N. J.
 Sapirstein, R. L., 1452 N. Fuller Ave., Los Angeles 46, Calif.
 Sauer, H. H., 1342 Springfield Ave., Irvington 11, N. J.
 Schafer, E. L., 5312 Holly St., Bellaire, Tex.
 Shearer, W. G., Box 3116, MCL1, Wright-Patterson AFB, Dayton, Ohio
 Scherer, R. T., 4437 Grantley Rd., Toledo 13, Ohio
 Schloemer, R. D., 1024 McMorris Dr., Honolulu 18, Hawaii
 Schmidt, H., 361 E. 138 St., New York 54, N. Y.
 Scholl, G. S., Box 53, Silver Spring, Md.
 Seats, P., 118 Ninth St., Passaic, N. J.
 Sebastian, R. W., 544 S. Westmore Ave., Lombard, Ill.
 Seigler, J. D., 36 Wingra Ave., Rutherford, N. J.
 Simmonds, J., 43-01-22 St., Long Island City 1, L. I., N. Y.
 Simpson, R. H., 2209 David Dr., Fort Worth 11, Tex.
 Skaritka, R., 1919 S. Shelby Ct., Chicago 8, Ill.
 Skinner, A. M., Computation Laboratory, Wayne University, Detroit 1, Mich.
 Smith, R. W., 2220 Savannah Ter., S.E., Apt. 33, Washington 20, D. C.
 Smith, W. G., 2047 County Rd., Westbury, L. I., N. Y.
 Snow, S. D., 108 St. Paul St., Brookline 46, Mass.
 Sorenson, K. G., 3605 Alameda Des Las Pulgas, Menlo Park, Calif.
 Sotak, J. W., 1003 Ellison St., Falls Church, Va.
 Soufal, F. H., 4111 N. Central Park Ave., Chicago 18, Ill.
 Sowa, C. P., Box 89, Bldg. 60, Kelly AFB, San Antonio, Tex.
 Spargo, J. S., 56 Hillside Ave., Freeport, L. I., N. Y.
 Spears, M. F., 1929 Chatburn Ct., Fort Worth 10, Tex.
 Splitt, F. G., Jr., 1729 N. Keeler Ave., Chicago 39, Ill.
 Stankovich, D., 8 Ohio Ave., Lancaster, Pa.
 Stevenot, H. A., Box C 38, Sloatsburg, N. Y.
 Stickley, D. F., 6907 Schiller, Houston 24, Tex.
 Stineman, J. W., Jr., c/o F. B. Morris, County Line Rd., Villanova, Pa.
 Stone, E. W., 308 Merritt Ave., Syracuse 7, N. Y.
 Stone, H. A. G., Box 241, Belmar, N. J.
 Stone, M. V. H., Box 241, Belmar, N. J.
 Streeter, T. W., Jr., 1133 Evergreen Ave., Plainfield, N. J.
 Sturlesi, B. E., P.O.B., 1485, Jerusalem, Israel
 Suganuma, P. K., 321 First St., Niagara Falls, N. Y.
 Swallow, D. S., 1238 S. "N" St., Oxnard, Calif.
 Swanson, R. E., I.B.M., Engineering Laboratories, Poughkeepsie, N. Y.
 Szmanski, W. C., 208 S. Eighth St., Philadelphia 7, Pa.
 Tado, S. T., 1651 N. Artesian, Chicago 47, Ill.
 Tamir, T., 15 Moriah St., Haifa, Israel
 (Continued on page 156A)

Hermetic Seal Products Co.

29 South Sixth Street
Newark 7, New Jersey

FIRST AND FOREMOST IN MINIATURIZATION

There is Always One Leader in Every Field

BODNAR INDUSTRIES, Inc.

leads in the field of
TRANSILLUMINATED PLASTIC LIGHTING PLATES

BECAUSE OF *Quality • Uniformity • Performance*
Design & Layout "Know-How Service"
Quantity Production Promptly

NEW YORK —19 Railroad Ave., New Rochelle (Home Office)
 TEXAS —208 West Avery, P.O. Box 4116, Station A, Dallas
 CALIFORNIA—4440 Lankershim Blvd., P.O. Box 264, North Hollywood
 CANADA —313 Montreal Trust Bldg., 67 Yonge St., Toronto
 SPECIMEN PANEL MIL-P-7788 (AN-P-89) SENT ON LETTERHEAD REQUEST

Are your High-Cycle Alternator requirements *special?*

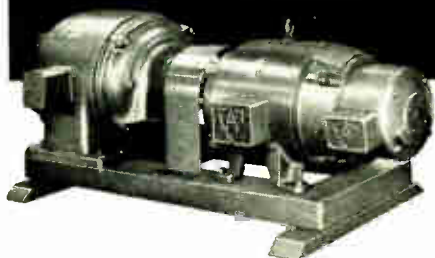

Where lowest possible maintenance, combined with excellent wave form characteristics are required, it's hard to match American Electric's Inductor-Type Alternators. But occasionally *special requirements* arise which may be better served by American Electric's Revolving Field Alternators.

Here Are Quick Facts:

**AMERICAN ELECTRIC
REVOLVING FIELD ALTERNATORS**
CAPACITY RANGE—15 KVA to 40 KVA
(in stock). Up to 75 KVA on special
order.

FAST RECOVERY—Better than .2 seconds.

LOW VOLTAGE OVERSHOOT—Less than 10%.

TOTAL HARMONIC CONTENT—Under 5% on
unbalanced 3-phase loads

These character-
istics apply to
general uses. Where
applications are
specific, even better
characteristics can
be developed.



EXCITER REGULATING SYSTEM

Employs American Electric's trouble-free, direct-connected, high-cycle Inductor Alternator—which has no commutator, slip rings, brushes, springs etc. Output is rectified and exciter-regulated by either electronic or magnetic amplifier means then returned to the rotating field of the main alternator.

Write for details and quotations outlining requirements.
Also Manufacturers of High Frequency Inductor
Alternators, Miniature Electric Motors, A.C. Industrial
Motors, Motor Driven Blowers and Fans.



4811 Telegraph Road,
Los Angeles 22,
California

FIELD ENGINEERING REPRESENTATIVES:

TRAVCO ENGINEERING COMPANY—Silver Spring (Md.)
• Boston • Buffalo • New York City • Chicago •
Dallas • Kansas City • Wright Field • Minneapolis
• Seattle • Montreal • Toronto
JOE DAVIDSON & ASSOCIATES, Los Angeles.

SPACE TIGHT? USE JOHNSON TYPE "E" AND "F" CAPACITORS

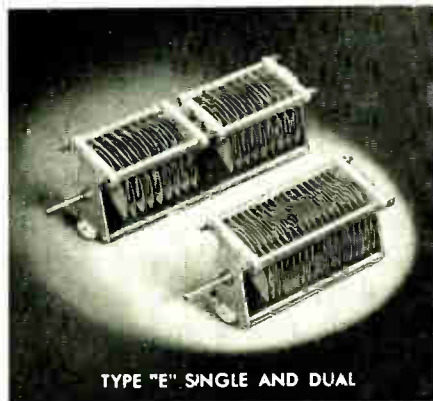

TYPE "E" SINGLE AND DUAL

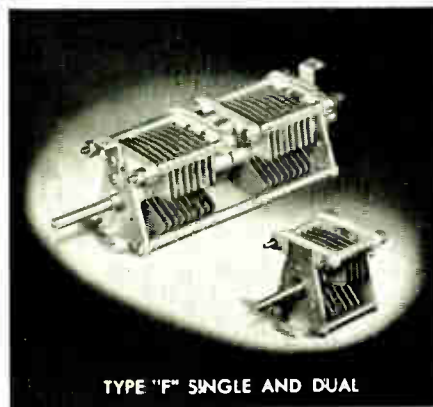

TYPE "F" SINGLE AND DUAL

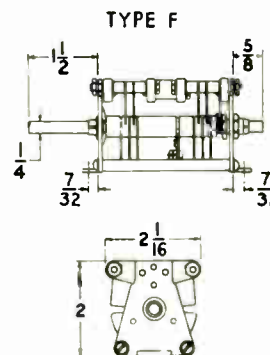
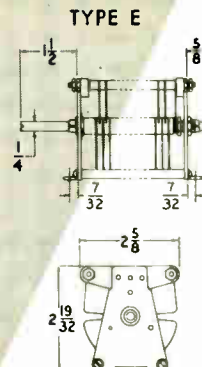

LESS PANEL AREA—MORE CAPACITY PER CUBIC INCH!

Rugged and compact, JOHNSON Type "E" and "F" Capacitors for medium and low power transmitters have more capacity per cubic inch and occupy less panel space for their ratings than any other capacitor on the market.

In addition, their simple, functional design provides extremely good mechanical rigidity and exceptional electrical performance. Points of superiority include steatite insulation, heavy aluminum plates with rounded edges, 1/4" tie rods, efficient cadmium plated phosphor bronze

contacts and stainless steel shafts. Designed for chassis mounting with stator up to reduce capacity to ground, they have unusually low minimum capacity ratings.

Available in 40 different models, single and dual sections with plate spacings from .045" to .125" and maximum capacities from 35 to 500 mmfd.

Quotations on standard models or "specials" to meet your requirements are available on request. Investigate Johnson's "E" and "F" Capacitors for your application today!

Write for the **NEW** Johnson General Products Catalog #975.



E. F. JOHNSON COMPANY

CAPACITORS • INDUCTORS • SOCKETS • INSULATORS • PLUGS • JACKS • KNOBS • DIALS AND PILOT LIGHTS

2118 SECOND AVENUE SOUTHWEST • WASECA, MINNESOTA

At the I.R.E. Show, thousands discovered

the pioneer
is the leader

HOW TO SAVE MONEY BY SAVING TIME with PANORAMIC EQUIPMENT

NEW

Panoramic Model

SPA-1

**A Convenient Single
Package VHF-UHF
Spectrum Analyzer
50MC-950MC with
Two RF Tuning Heads**

The Model SPA-1 Panoramic Spectrum Analyzer incorporates a superior panoramic indicator, power supply and optional tuning heads, RF-2 and RF-3, which cover the ranges between 50MC to 250MC and 220MC to 950-MC, respectively. The SPA-1 is exceptionally simple to operate, lending itself to production tests as well as laboratory usage.

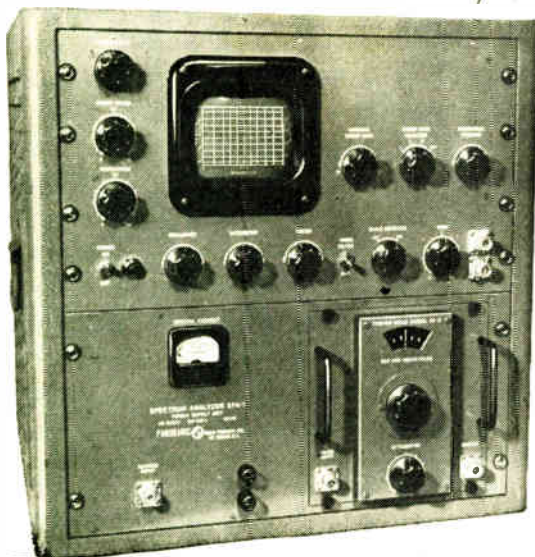

- Direct Frequency Reading, 50MC-950MC
- 10MC scanning width, continuously reducible to almost 0KC
- Sweep Rates: 1cps, 5cps, 30cps and 25-35cps, variable
- High inherent stability
- Low cost
- Variable resolution 9KC-100KC

Model **SG-1** Panoramic's NEW Sweep Generator

for Accurate Inspection of Responses
of Sonic and Ultrasonic Systems and Devices

- Direct Frequency and Amplitude Reading Screen for Slave Scopes
- Frequency Range: 40cps-20KC, 400cps-200 KC, selectable
- Frequency scales: logarithmic or linear, selectable
- Scan rate 1cps internal; 60-0.04cps external with Model TW-1 Triangular Wave Generator
- Amplitude scales: linear or 2 decade logarithmic, selectable
- Variable linear sweep range
- Internal frequency markers



Panoramic's NEW

Model **FM-1** FM Monitor

A Low Cost Portable Package for Rapid Visual
Measurement of Actual Bandwidth of Mobile FM
Transmissions

- Instantaneous panoramic presentations of carrier and sidebands of voice transmissions
- Helps prevent channel spillover
- Indicates modulation symmetry
- Accurately measures deviation by constant tones
- Has band limit markers
- Simple to operate



If you missed the I.R.E. Show—and the PANORAMIC demonstration of these new and important instruments at work on actual problems—write today for full information.

Inquiries invited on Panoramic Spectrum Analyzers for Special Problems.

12 South Second Avenue, Mount Vernon, N.Y.
Mount Vernon 4-3970



(Continued from page 154A)

- Tanaka, G. J., 1449 Post St., San Francisco 9, Calif.
Teitelbaum, M., 5120 Fort Hamilton Pkwy., Brooklyn 19, N. Y.
Teske, H. O., 30 W. Chicago, Rm. 1017, Chicago 10, Ill.
Theiss, J. B., 223-D Garfield Ave., Collingswood 7, N. J.
Thomson, W. E., 5803 Bellaire Blvd., Bellaire, Tex
Totten, G. A., 1911 E. 31 St., Topeka, Kans.
Underwood, M. D., River Rd., Chatham, N. J.
Van-Aken, H., Jr., General Electric Co., Electronics Park, Syracuse, N. Y.
Wagner, E. G., 220 Main St., Poughkeepsie, N. Y.
Walker, H. O., Jr., 1522 Auline La., Houston 24, Tex.
Wallace, S. K., Box 744, Lutz, Fla.
Walthour, R. L., External Branch OGMS, Redstone Arsenal, Huntsville, Ala.
Wedge, T. E., 3500 Dudley Ave., Baltimore 13, Md.
Weidner, C. P., 5413 Hidalgo, Houston 19, Tex.
Welsand, J. B., 12018 Kilbourne, Detroit 13, Mich.
West, R. W., 3023 Aliso Dr., N.E., Albuquerque, N. Mex.
Westemeier, T. F., 9301 TSU-ORD (BRL), Aberdeen Proving Ground, Md.
Western, C., 152 Main St., Toronto, Ont., Canada
White, R. C., 229-04A—67 Ave., Bayside 64, L. I., N. Y.
Wickham, W. S., 6018 Monmouth Rd., Houston 19, Tex.
Williamson, R. J., 52 Edgewood Ave., New Providence, Ill.
Wilson, C. V., Jr., 1810 W. 14½ St., Houston, Tex.
Witt, S. N., Jr., 633 Channing Dr., N.W., Atlanta, Ga.
Woerner, R. G., 167 Elmwood St., Valley Stream, L. I., N. Y.
Wolff, L. E., 11401 O'Donnell Dr., Houston 22, Tex.
Wright, R. H., 6903 Schiller, Houston, Tex.
Zapalac, R., 2227 Mimosa La., Houston, Tex.
Zatlin, F. R., Jr., 39 Beverly Rd., Wellesley 81, Mass.
Zettler, W. R., Raytheon Manufacturing Co., Waltham 54, Mass.
Ziller, M. A., 4 Holland Ave., Long Branch, N. J.
Zimmerman, D. N., 306 Comm Recon Bn., Fort Bragg, N. C.
Zingg, J. F., 75 Galewood Dr., Fairborn, Ohio
Zombolas, G. P., 1009 N. Ross Ave., Sherman, Tex.
Zucker, S. M., 38 Hodges Pl., Staten Island 14, N. Y.

IRE Directory

**10 Product Directories
in One!**

1. Audio Equipment
2. Broadcasting
3. Communications
4. Components
5. Electronic Applications
6. Radar-Microwave
7. Services, Materials and Consultants
8. Test Equipment
9. Education
10. Distribution

You will be able to get facts and information faster in this DIRECTORY, and with more complete detail, than can be found in any other product reference.

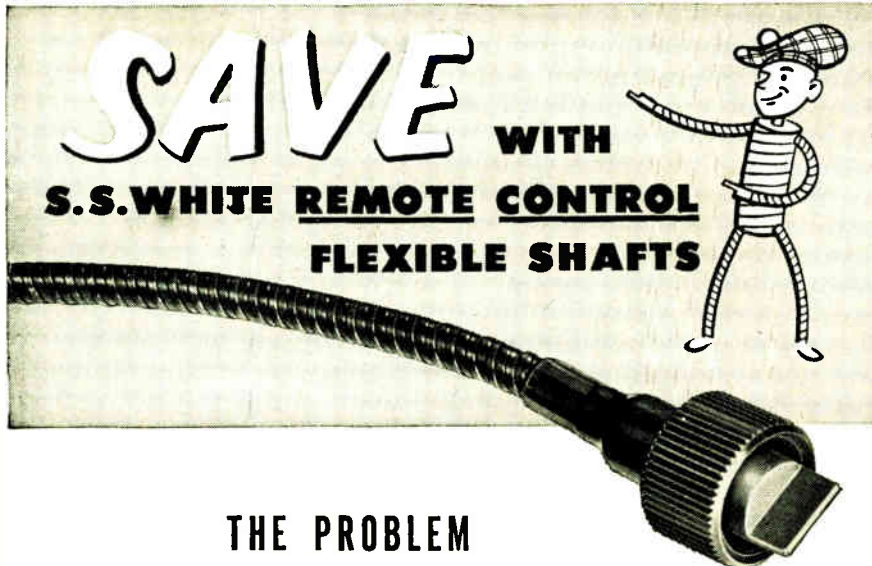

THE PROBLEM

TO CONTROL AN INACCESSIBLE PART

The designer of the unit pictured below was faced with the problem of providing an economical method of operating an inaccessible rotary switch from a convenient point outside the unit. The control linkage had to have a minimum degree of "backlash" and had to be run around a 90° turn. The designer considered the many ways in which the control set-up could be done and finally decided on

THE LOW-COST SOLUTION

AN S.S. WHITE REMOTE CONTROL FLEXIBLE SHAFT

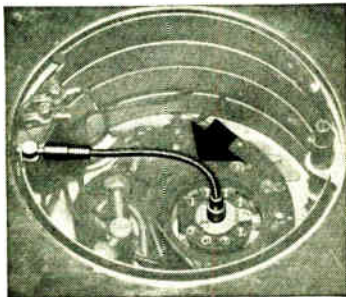

By using an S.S. White remote control flexible shaft, the designer was able to control the switch with a single part which is easy to install, requires no alignment, and needs no attention once installed. As a result, he was able to make substantial savings in manufacturing and assembly costs with full assurance that the

flexible shaft would fully meet his rigid service specifications. Why not discuss your remote control problems with S.S. White engineers. Their helpful advice and cooperation will show you where you can make similar savings.

Up-to-date Flexible Shaft Information—

This 256-page flexible shaft handbook will be sent free if you request it on your business letterhead. It contains full facts and data on flexible shaft selection and application.



THE S.S. White INDUSTRIAL DIVISION
DENTAL MFG. CO.



Dept. G, 10 East 40th St.
 NEW YORK 16, N. Y.

Western District Office • Times Building, Long Beach, California

New components, designs and techniques for HIGH VOLTAGE and CORONA SUPPRESSION

Here's a brand new technique . . . makes possible connectors and cables wherein insulation is molded right around contact and lead . . . to give you an integral unit that licks the problems of high voltage and corona suppression at new low cost, by—

- 1 Eliminating need of leakage paths at wire holes.
- 2 Utilizing materials more inert to ozone attack than conventional materials.
- 3 Sealing high voltage potential sources from air except at the point of contact mating, where there is a natural damping of corona.

This new technique just worked out for Color TV can give you connectors and cables for solving many problems involving high voltage and corona suppression.

NEW SOCKET TECHNIQUE

As illustrated in this Alden 220FTSC Color TV Tube Connector, the new technique permits a jacket of high voltage insulation to be integrally molded around each high voltage contact and lead, while the low voltage leads take the resilient "figure 8" clips in the regular isolated pockets providing air space leakage.



NEW CABLE TECHNIQUE



This new technique makes possible completely molded cables having all connectors and wire insulation sealed into an integral unit that licks the problems of high voltage and corona suppression. For example, the 30,000-volt anode cable illustrated has in-line tube cap, high voltage disconnect and anode clip all molded together as one integrated unit tailored for a Color TV set.



8101FP/M
 High Voltage Disconnect for 20,000 volt anode cable.



8111FP/M
 High Voltage Disconnect for 30,000 volt anode cable.



91-IS2L-1BC
 Molded in-line Tube Cap.

ADDITIONAL ADVANTAGE—this new technique gives a solidly molded unit that eliminates common cable problems of: wire fatigue under vibration; insulation pullback; strain relief for leads.

TO GET STARTED

write for Spec Sheets on Color TV—and let us plan these techniques to your special needs in ANY field involving high voltages and corona suppression.



ALDEN PRODUCTS CO.

5121 N. Main St., Brockton 64, Mass.



BRUSHES CONTACTS

SLIP RINGS

...AND SLIP RING ASSEMBLIES



BRUSHES — CONTACTS — ASSEMBLIES

... Use **SILVER GRAPHALLOY** for applications requiring low electrical noise; low and constant contact drop; high current density and minimum wear.

EXTENSIVELY USED IN:

**SELSYNS • GUN FIRE CONTROLS
ROTATING THERMOCOUPLE and
STRAIN GAGE CIRCUITS
ROTATING JOINTS • DYNAMOTORS**

Wide range of grades available for standard and special applications.

Other Graphalloy Products



Oil-free, self-lubricating Bushings and Bearings (applicable —100° to +300 F.) with expansion coefficient half that of steel will not seize shafts at low temperature; oil-free Piston Rings, Seal Rings, Thrust and Friction Washers, Pump Vanes.

GRAPHITE METALLIZING CORPORATION

1001 NEPPERMAN AVE. • Yonkers, New York

- Please send data on Graphalloy BRUSHES and CONTACTS.
 Send data on BUSHINGS.

NAME & TITLE _____
COMPANY _____
STREET _____
CITY _____ ZONE _____ STATE _____

1954 IRE DIRECTORY

10 Directories in One

104 Basic Product Listings

608 Product Sub-classifications

The only complete Directory of Engineers, Firms, and Products serving the Radio-Electronic market.

35,000 Engineers will read and use this Industry-Guide in 1954-1955.

Advertising Deadline:

June 1st—For copy to set ads

June 15th—For complete plates

IRE DIRECTORY

1175 Broadway, New York 36, N.Y.

Telephone: BRyant 9-7550

NEW Carter SLIDE CHART



SHOWS DYNAMOTOR EFFICIENCY

25¢ at a Glance!

AT YOUR RADIO PARTS
DISTRIBUTOR OR
ELECTRONIC EQUIPMENT
SUPPLIER

Now it's easy to compare Dynamotor performance efficiency under actual operating conditions. Nameplate information plus this simple slide chart enables you to read instantly the efficiency percentage right from the Calculator scale. Reverse side gives other useful information. Handy 3" x 6" pocket size, color printed on sturdy laminated stock, varnished to resist soil. For sale by radio parts distributors and electronic equipment suppliers, or 25¢ postpaid.

**WRITE for FREE
DYNAMOTOR
CATALOG**

Carter Motor Co.

2645 N. MAPLEWOOD AVE. CHICAGO 47

World's largest Exclusive Manufacturers of mobile radio rotary power Supplies.

News—New Products

These manufacturers have invited PROCEEDINGS readers to write for literature and further technical information. Please mention your I.R.E. affiliation.

(Continued from page 153A)

New Book

N. V. Philips Gloeilampenfabriken, Eindhoven, the Netherlands, has published and released a new book through their Technical and Scientific Literature Dept.

The work, **Industrial Electronics**, has 250 pages, 266 illustrations, and was written by Dr. R. Kretzmann.

The book is divided into two basic sections: Part I which lists 9 types of tubes and their basic circuits, and Part II which lists 10 electronic devices for industrial purposes.

This manual is distinguished from other books in the field in that it is largely devoted to a detailed descriptive study of successful modern devices of many types employing electronics, with numerous circuit diagrams and photographs.

Distributors: Messrs. Elsevier Press, Inc., 402 Lovett Boulevard, Houston 6, Texas, and 155 East 82 St., New York 28, N. Y.

Price: U.S.A. \$5.50.

DC Amplifier

The Model 3501 DC Amplifier, manufactured by **The Ralph M. Parsons Co.**, 135 W. Dayton St., Pasadena, Calif., has been designed for use in special purpose computer circuits. Dc drift, noise, and nonlinearities have been held to an absolute minimum, the firm claims.

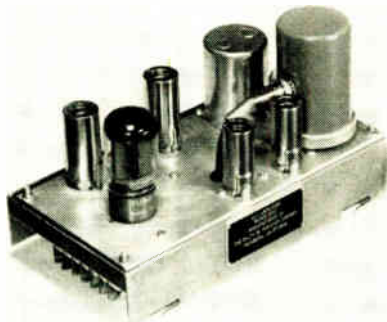

Contact stabilized with a 60 cps chopper, the output is linear with ± 0.01 per cent of maximum output up to ± 140 volts for loads as low as 10 k and up to ± 100 volts for loads as low as 5 k. Output ripple is less than 0.50 millivolts rms and the normal 24-hour drift for a temperature rise of from 10 degrees to 60 degrees C is less than 0.5 millivolt after 15 minute warmup.

The normal open-loop gain exceeds 10⁶; fixed gains may be obtained accurate to ± 0.01 per cent. The Cd plated plug-in steel chassis may be mounted wherever convenient since there are no operating controls on the chassis.

(Continued on page 165A)

SERVOBIRD

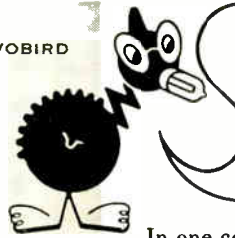

**"Wanna Nyquist Diagrammed?
A Function Transferred?"**

In one convenient instrument, here is test equipment for determining, in design or production phases, the dynamic performance of regulators, governors, process controls, positioning servomechanisms.

Only the SERVOSCOPE®

has all these features:

- Applicable to both AC carrier and DC servo systems.
- Generates: 1. Sine-wave modulated carrier 2. Low frequency sine wave 3. Low frequency square wave
- Built-in electronic sweep with no sweep potentiometer to wear out and require replacement.
- Dynamic frequency control range of 200 to 1.

For detailed specifications
write Dept. IRE-5.

SERVO
CORPORATION OF AMERICA
New Hyde Park, New York

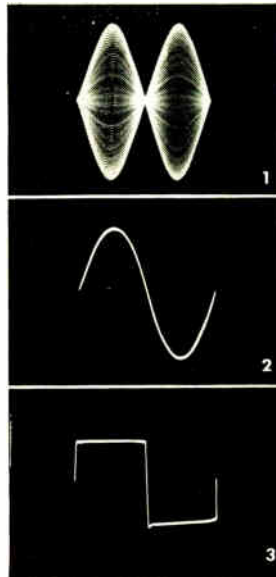

Output wave forms of Servoscope displayed against internal linear sweep generator, frequency 1/2 cycle.

Rutherford ELECTRONICS CO. MAKES PRECISION TIMING INSTRUMENTS

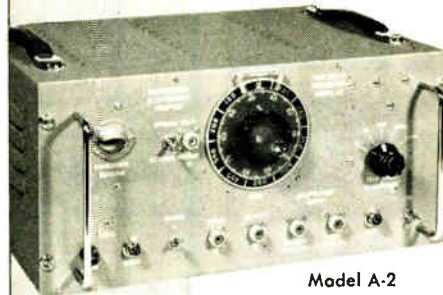

Model A-2

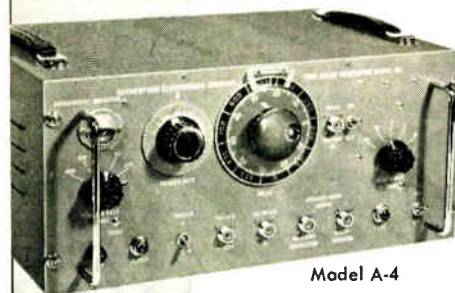

Model A-4



Our
TIME DELAY
GENERATORS:

Each provides accurate and variable time intervals in five ranges. They feature low jitter (.008%), linear scales, built-in calibration indicator, 1,000-division dial, small repetition rate effects, blocking oscillator output and wide pulse output.

A-2 — Range: .8 μ s to 100,000 μ s
Get complete data: our Bulletin 1-A-2

A-4 — Range: .00001 to 10 secs.
Get complete data: our Bulletin 1-A-4

Rutherford ELECTRONICS CO. Telephone: TEexas 0-4362
3707 S. ROBERTSON BLVD.
CULVER CITY, CALIFORNIA

COMMUNICATIONS EQUIPMENT CO.

MICROWAVE COMPONENTS



"S Band," RG48/U Waveguide

POWER SPLITTER for use with type 726 or any 10 CM Shepherd Klystron. Energy is fed from Klystron antenna through dual pick-up system to 2 type "N" connectors. \$22.50 EACH

DIRECTIONAL COUPLER, Broad-band type "N" Coupling, 20 db. (shown) Navy SCABV47AAN-2 (as shown) \$37.50

LHTR LIGHTHOUSE ASSEMBLY, Part of RT99 APG 5 & APG 15, Receiver and Trans. Cavities w/assoc Tr. Cavity and Type N CIPAG, To Recv. Uses 2C40, 2C43, 1B27, Tunable ATX 2400-2700 MCS, Silver Plated \$49.50

BEACON LIGHTHOUSE cavity p/o UPN-2 Beacon 10 cm. Mfg. Bernard Rice, each \$47.50

MAGNETRON TO WAVEGUIDE Coupler with 721-A Duplexer cavity, gold plated \$45.00

RT-30 APG-5 10 cm. lighthouse RF head c/o Xntr., Recv-Tx, cavity compl. recv. & 30 MC IF strip using 60K5 (2C40, 2C43, 1B27 lineup) w/Tubes. \$12.50

721A TR BOX complete with tube and tuning plungers \$12.50

MENALLY KLYSTRON CAVITIES for 7071K or 7K28 \$4.00

WAVEGUIDE TO RIGID COAX "DOOR-KNOR" ADAPTER CHOKE FLANGE, SILVER PLATED BROAD BAND \$32.50

AS14A AP-10 CM Pick up Dipole with "N" Cables \$4.50

OAJ ECHO BOX, 10 CM TUNABLE \$22.50

HOLMDELL-TO-TYPE "N" Male Adapters, W.E. 2D167284 \$2.75

I.F. AMP. STRIP: 30 MC, 30 db. gain, 4 MC Bandwidth, uses 6AC7's with video detector, A.F.C. less tubes \$24.50

BEACON ANTENNA, AS81/AIN-7 in Lucite Ball, Type "N" feed \$22.50

ANTENNA, AT-49A/APR: Broadband Conical, 300-3300 MC Type "N" Feed \$12.50

"E" or **"H"** PLANE BENDS, 90 deg. less flanges \$7.50

X Band— RG 52/U WAVEGUIDE

VSWR Measuring Section, Consisting of 6" straight section, with 2 pick-up, Type "N" Output Jacks. Mounted 1/2 Wave apart \$8.50

1" x 1/2" waveguide in 5' lengths, UG 39 flanges to UG40 cover per length \$7.50

Rotating Joints supplied either with or without deck mounting. With UG40 flanges each \$17.50

Bulkhead Feed-thru Assembly \$15.00

Pressure Gauge Section 15 lb. gauge and brass nipple \$10.00

Pressure Gauge, 15 lbs. \$2.50

Directional Coupler, UG 40/U Take off 20db \$17.50

TR-ATR Duplexer section for above \$8.50

Waveguide Section 12" long choke to cover 45 deg. twist & 2 1/2" radius, 90 deg. bend \$4.50

Waveguide Section 3 ft. long silver plated with choke flange \$5.75

Rotary joint choke to choke with deck mounting \$17.50

90 degree elbows, "E" plane 2 1/2" radius \$12.50

Microwave Receiver, 3 CM, Sensitivity: 10-13 μ Watts. Complete with L.O. and AFC Mixer and Waveguide Input Circuits, 6 I.F. Stages give approximately 120 db gain at a bandwidth of 1.7 MC. Video Bandwidth: 2 MC. Uses latest type AFC circuit. Complete with all tubes, including 723A/B Local Oscillator \$175.00

ADAPTER, waveguide to type "N", UG 81/U, p/o TS 12, TS-13, Etc. \$27.50

ADAPTER, UG-163/1" round cover to special bit. Flange for TS-45, etc. \$2.50 ea.

K Band—1/2" x 1/4" W.G. 1.25 CM.

APS-34 Rotating Joint \$49.50

Right Angle Bend E or H Plane, specify combination of couplings desired \$12.00

45° Bend E or H Plane, choke to cover \$12.00

Mitered Elbow, cover to cover \$4.00

TR-ATR Section, Choke to cover \$4.00

Flexible Section 1" choke to choke \$5.00

"S" Curve Choke to cover \$4.50

Adapter, round to square cover \$5.00

Feedback to Parabola Horn with pressurized window \$27.50

90° Twist \$10.00

JAN WAVEGUIDE FLANGES

UG 39/U	\$1.10	UG 51/U	\$1.65
UG 40/U	\$1.25	UG 52/U	\$3.40
UG 40A/U	\$1.65	UG 52A/U	\$3.40

MAGNETRONS

Type	Freq. Range(MC)	Peak Power Out (KW)	Duty Ratio	Price
2J21A	9345-9405	50		\$8.75
2J22	3267-3333	265		7.50
2J27	2965-2992	275	.002	19.95
2J31	2820-2860	285	.002	24.50
2J32	2780-2820	285	.002	28.50
2J38*	3249-3263	5		16.50
2J39*	3267-3333	8.7		24.50
2J48	9310-9320	50	.001	24.50
2J49	9000-9160	50	.001	59.50
2J56*	9215-9275	50	.001	132.50
2J61†	3000-3100	35	.002	34.50
2J62†	2914-3010	35	.002	34.50
700B	690-700	40	.002	22.50
700D	710-720	40	.002	39.75
706EY	3038-3069	200	.001	32.50
706CY	2976-3007	200	.001	32.50
725-A	9345-9405	50	.001	Write
730-A	9345-9405	50	.001	24.50
4J38	3550-3600	750	.001	169.45

*—Packaged with magnet.
†—Tunable over indicated range.

5J23 \$49 | QK-253 .. \$249
4J34 \$125 | 3J3J \$85

70 WATT C. W. MAGNETRONS*

QK-60 2800-3025 MC. QK-62 3150-3375 MC.
QK-61 2975-3200 MC. PRICE \$85 Ea.

*Tunable, and packaged with magnet.

—IN STOCK—

AIA	ASH	SO-8
APA-9	BG	SG-1
APA-10	DAS†	SJ-1
APN-3	DBS†	TAJ
APN-7	APT-2	TBK
APN-9*	APT-4	TBL
APS-2	MKIV	SCR520*
APS-3	MXK	SCR521
APS-4	RC145	SCR518
APS-6	RC148	
ASD	SO-1	

*COMPONENTS. †LORAN EQUIPMENT

—TEST SETS—

TS-10	TS-12	TS-159
TS-36	TS-56	TS-268
TS-47	TS-34	TS-270

I. F. AMPLIFIER STRIPS

MODEL SO: 30 Mc gain figure is 120 db. Bandwidth: 2Mc. Uses 6 stages of 6AC7 Plus one video detector. Less Tubes \$24.50

Model 15: 30 Mc center frequency. Bandwidth 2.5 Mc. gain figure: 65 db. Uses 5 stages of 6AC7's. Has D. C. Restorer and Video Detector, A.F.C. Strip included. Input impedance: 50 Ohms. Less tubes \$27.50

Model APS-4: Miniature IF strip, using 6AK5's 60 Mc center Freq. Gain: 95db at Bandwidth of 2.7 Mc. Less tubes \$45.00

THERMISTORS

D-164699 Bead Type DCR: 1525-2550 Ohms @ 75 Deg. F. Coefficient: 2% Per Deg. Fahr. Max. Current 25 MA AC/DC \$2.50

D-167332 Bead Type, DCR is 1525-2550 Ohms. Rated 25 MA at .825-1.175 VDC \$1.35

D-167613 Disk Type DCR: 355 Ohms @ 75 Deg. F.P.M. 2.5%. 1 Watt \$1.35

D-166228 Disk Type 7120 Ohms @ 60°F. 4220 Ohms @ 80°F. 2590 Ohms @ 100°F. 1640 Ohms @ 120°F. \$1.35

PULSE NETWORKS

15A—1-400-50: 15 KV. "A" CKT. 1 microsec. 400 PPS, 50 ohms imp. \$37.50

G.E. 23E (3-84-810) 8-2-24-405 50P4T .3KV "E" CKT Dual Unit: Unit 1, 3 sections, 0.84 Microsec. 810 PPS, 50 ohms imp.; Unit 2, 8 Sections, 2.24 microsec. 405 PPS 50 ohms imp. \$6.50

7-5E1-200-67P, 7.5 KV "E" Circuit, 1 microsec, 200 PPS, 60 ohms impedance 3 sections 1-711. 4-89-10

7-5E4-16-60, 67P, 7.5 KV "E" Circuit, 4 sections 16 microsec, 60 PPS, 67 ohms Impedance \$15.00

7-5E3-3-200-67P, 7.5 KV, "E" Circuit, 3 microsec, 200 PPS, ohms imp. 3 sections \$12.50

2755: 10KV, 2.2usec., 375 PPS, 50 ohms imp. \$27.50

2754: 10KV, 0.8usec., 750 PPS, 50 ohms imp. \$27.50

KS8865 CHARGING CHOKE: 115-150 It @ 0.2A, 32 —40H @ .08A, 30.700V Corona Test, 21KV Test \$37.50

G.E. 25E5-1-350-50 P2T "E" SKT, 1 Microsec. Pulse @ 350 PPS, 50 OHMS Impedance \$69.50

KS9623 CHARGING CHOKE: 161I @ 75 MA, 380 Ohms DCR, 000 Vac test \$14.95

G.E. 6E3 .5-2000 50 P2T: 6 KV "E" Circuit 0.5 usec /2000 PPS/50 ohms/2 sections \$7.50

PULSE EQUIPMENT

MIT, MOD. 3 HARD TUBE PULSER: Output Pulse Power 144 KW (12 KV at 12 Amp). Duty Ratio: .001 max. Pulse duration: 5, 1.0, 2.0 microsec. Input voltage: 115 v, 400 to 2400 cps. Uses: 4-711, 4-89-10, 3-72's, 1-73, New \$135.00

TPS-3 PULSE MODULATOR, Pk. power 50 amp, 24 KV (1200 KW pk): pulse rate 200 PPS, 1.5 microsec. pulse line impedance 50 ohms. Circuit series charging version of 1K3 Resonance type. 150 Ohms 705-A's as rectifier. 115 VAC cycle input. New with all tubes \$49.50

PULSE TRANSFORMERS

RAYTHEON WX 4298E: Primary 4KV., 1.0 I' SEC. SEC.: 16KV-16 AMP DUTY RATIO: .001 400 OHMS PTL TRANS "BUILT-IN" \$42.50

WECO: KS 9948: Primary 700 ohms. Sec: 50 ohms. Plate Voltage: 18 KV. Part of APQ-13 \$12.50

GE 2K-2449A
Primary: 9.33 KV, 50 ohms Imp.
Secondary: 28 KV, 450 ohm
Pulse length: 1.0/5 usec @ 635/120 PPS, Pk Power Out: 1.740 KW
Bifilar: 1.5 amps (as shown) \$62.50

GE 2K-2748-A, 0.5 usec @ 2000 Pps, Pk. Pwr. out is 32 KW impedance 40:100 ohm output, Pri. volts 2.3 KV Pk. Sec. volts 11.5 KV Pk. Bifilar rated at 1.3 Amp. Fitted with magnetron well \$39.50

K-2745 Primary: 3.1/2.8 KV, 50 ohms Z; Secondary: 14/12.6 KV 1025 ohms Z; Pulse Length: 0.25/1.0 usec @ 600/600 PPS, Pk. Power 200/150 KW. Bifilar: 1.3 Amp. Has "built-in" magnetron well \$42.50

K-2461-A, Primary: 3.1/2.6 KV—50 ohms (line). Secondary 14/11.5 KV—1000 ohms Z, Pulse Length: 1 usec @ 600 PPS, Pk. Power out: 200/130 KW. Bifilar: 1.3 Amp. Fitted with magnetron well \$39.75

UTAH X-1517-1: Dual Transformer, 2 Wdgs. per section 1:1 Ratio per sec 13 MH inductance 30 ohms DCR \$7.50

UTAH X-1507-1: Two sections, 3 Wdgs. per section, 1:1 Ratio, 3 MH, 6 ohms DCR per Wdg. \$7.50

68G711, Ratio: 4:1, Pri: 200V, Sec: 53V, 1.0 usec Pulse @ 2000 PPS, 0.016 KVA \$4.50

TR1049 Ratio: 2:1 Pri, 220 MH, 50 Ohms, sec. 0.75 H, DCR 100 Ohms \$6.75

K-904695-501: Ratio 1:1, Pri. Imp. 40 Ohm, Sec. Imp. 40 Ohms, Passes pulse 0.6 usec with 0.05 usec rise \$8.95

Ray UX 7896—Pulse Output Pri. 5v sec. 41v \$7.50

Ray UX 8442—Pulse Inversion—40v + 40v \$7.50

PHILCO 352-7250, 352-7251, 352-7287

RAYTHEON: UX8693, UX5986 \$5 ea.
W.E.: D-166310, D-166638, K59800, K59948.

UTAH 2922, with Cracked Beads, but will operate at full rated capacity \$24.50

UX 8893 (SCS 2299627-54): 3 Wdgs, 32 turns 218 wire, DCR is: 362/372/4 ohms. Total voltage 2500 vdc \$5.00

D-166173: Input: 50 ohms Z, Output: 500 ohms Z Wdgs, Freq range 10 kc-2mc, P/o AN/APQ-13 \$12.50

K-2450: Pulse Inversion auto-transformer; primary 13 kv, 4 usec, Output: 14 kv @ 100 kv peak \$34.50

MICROWAVE ANTENNAS

AT49/APR—Broadband Conical, 300-3300 MC, Type N Feed \$8.95

AS-31/APN-7: 10 cm Polysty in Lucite Ball, Type N Fitting Coax Feed \$22.50

Relay System Parabolic reflectors approx. range 2000 to 6000 Mc. Dimensions 4 1/2" x 3", New \$100.00

Dipole for above \$12.00

Parabolic Peel, Radiation pattern approx. 25 deg. in horizontal 33 deg. in vertical planes \$35.00

Cone Antenna, AS 125 A/P, 1000-3200 mc. Stub supported with type "N" connector \$14.50

AS14A/AP, 10 CM pick up dipole, assy. complete w/length of coax and "N" connectors \$4.50

AS46A/APG-4 Yagi Antenna, 5 element array \$22.50

30" Parabolic Reflector Spun Aluminum dish \$485

APS-34 Pillbox Antenna, waveguide input: 24,000-27,000 MC \$22.50

SCR 584, Dishes Perforated, Metal Construction \$185.00

MAIL ORDERS PROMPTLY FILLED. ALL PRICES F.O.B. NEW YORK CITY. SEND M.O. OR CHECK. ONLY SHIPPING SENT C.O.D.

RATED CONCERNS SEND P.O. ALL MDSE. SUBJECT TO PRIOR SALE, AND PRICES SUBJECT TO CHANGE WITHOUT NOTICE.

PARCELS IN EXCESS OF 20 POUNDS WILL BE SHIPPED VIA CHEAPEST TRUCK OR RAILCAR.

131 Liberty St., New York 7, N. Y. Dept I-5 Chas. Rosen Phone: Dlgby 9-4124

IRE DIRECTORY QUESTIONNAIRE

Send to: Industry Research Div., Institute of Radio Engineers
1475 Broadway, 22nd Floor, New York 36, N. Y.

Date

Firm Name: Phone No.

Address: City Zone State

Name of: Chief Engineer

Advertising Manager

1-54 Purchasing Agent

Method to be used by firms to indicate products manufactured or services rendered. Please read the entire questionnaire. Products are grouped beneath basic headings to facilitate location.

Do not check products that you do not manufacture for sale to the industry.

Components manufactured for incor-

poration in your own end products (and not intended for sale) should not be listed, as this will only result in annoyance to you, and the firms who make inquiries concerning product availability.

If, after a thorough examination of this form, you do not find a listing for your products, a short description and litera-

ture or catalogs that you have should be attached and returned to us.

After checking off the products, please fill in full data on your firm name and address, and mail the entire form to: Frank MacAloon, Industry Research Div., Institute of Radio Engineers, 1475 Broadway, New York 36, N. Y.

Industry Research Division Information Service

1. Audio Frequency Equipment.

01 Amplifiers.

- 05 Decade amplifiers
- 10 Dynamic noise suppressors
- 15 Hearing aid
- 20 High fidelity
- 25 Inter-coms
- 30 Phonograph pre-amplifiers
- 35 Power amplifiers—recording
- 40 Public address

02 Attenuators.

- 05 Decade
- 10 Impedance matching
- 15 Volume controlling

03 Equalizers.

- 05 Dialogue equalizers
- 10 Line equalizers
- 15 Magnetic recording
- 20 Recording diameter equalizers
- 25 Sound effect equalizers

04 Filters.

- 05 Band pass & band rejection
- 10 Loudspeaker dividing networks
- 15 Variable band pass

05 Industrial Sound Systems.

- 05 Complete systems
- 10 Installation & rental contractors

06 Jacks, Jack Fields & Plugs.

- 05 Jacks
- 10 Jack fields
- 15 Patch cords
- 20 Plugs

07 Loudspeakers & Headphones.

- 05 Commercial grade loudspeakers
- 10 Headphones
- 15 High-frequency loudspeakers
- 20 Low-frequency loudspeakers
- 25 Wide-range, 2 & 3 way systems

08 Microphones & Stands.

- 05 Carbon
- 10 Ceramic
- 15 Condenser
- 20 Crystal
- 25 Dynamic

- 30 Velocity
- 35 Microphone stands

09 Phonograph, Pick-ups, Record Changers, etc.

- 05 Phonograph motors
- 10 Pick-ups—crystal
- 15 Pick-ups—dynamic
- 20 Pick-ups—magnetic
- 25 Pick-ups—reluctance
- 30 Playback arms
- 35 Record changers
- 40 Record players
- 45 Styli—diamond
- 50 Styli—metallic
- 55 Styli—sapphire
- 60 Tape phonographs & playback equipment

10 Recording Accessories & Supplies.

- 05 Blank disks
- 10 Cutting heads
- 15 Cutting styli
- 20 Magnetic recording, playback & erase heads
- 25 Magnetic recording tape—acetate base
- 30 Magnetic recording tape—paper base
- 35 Magnetic recording wire
- 40 Stylus resharpening
- 45 Suction pumps & equipment
- 50 Tape splicing equipment

11 Recording Equipment.

- 05 Disk recorders
- 10 Embossing types of recorders
- 15 Magnetic tape recorders
- 20 Magnetic wire recorders

2. Broadcasting: Both Aural & Visual; Receivers, Transmitters & Associated Equipment.

12 Antennas & Accessories.

- 05 AM broadcast transmitting
- 10 FM broadcast transmitting
- 15 TV broadcast transmitting
- 20 Supporting towers

- 25 Tower lighting equipment
- 30 Tower erection & maintenance service

13 Monitor Equipment.

- 05 Frequency
- 10 Modulation
- 15 Remote control monitors
- 20 Video monitors

14 Receivers.

- 05 AM broadcast
- 10 AM shortwave
- 15 FM broadcast
- 20 TV broadcast — B & W
- 25 TV broadcast — Color

15 Services for the Broadcaster.

- 05 Frequency measurement
- 10 Packaged program services
- 15 Transcription libraries

16 Studio Equipment.

- 05 Consoles & speech input equip.
- 10 TV cameras
- 15 TV camera control equipment
- 20 TV film projectors
- 25 TV studio lighting equipment
- 30 Turntables

17 Transmitters.

- 05 AM broadcast
- 10 FM broadcast
- 15 TV broadcast
- 20 Relay broadcast & STL equip.

3. Communications: All non-broadcast forms of communication; Amateur, Emergency, Facsimile, Mobile, etc.

18 Aircraft & Airport Equip.

- 05 Airborne receivers
- 10 Airborne transmitters
- 15 Airport receivers
- 20 Airport transmitters
- 25 GCA equipment, etc.

19 Amateur Equipment.

- 05 Antennas & antenna accessories, rotators, etc.

- 10 Receiving equipment
- 15 Transmitters

20 Carrier Current Equipment.

- 05 Complete terminal equip.
- 10 Installation & maintenance
- 15 Repeat & relay equip.

21 Emergency Communication Equipment.

- 05 Despatching equipment
- 10 Walkie-talkies

22 Facsimile Equipment.

- 05 Receiving equipment
- 10 Sensitized paper
- 15 Transmitting equipment

23 Marine Equipment.

- 05 Contract installers
- 10 Pleasure craft radiotelephones
- 15 Shipborne communications equip.

24 Mobile Equipment.

- 05 Antennas
- 10 Central station receivers
- 15 Central station transmitters
- 20 Citizen radio
- 25 Mobile receivers
- 30 Mobile transmitters
- 35 Selective calling equipment

25 Point-to-Point Equipment.

- 05 Antennas & towers
- 10 Receivers
- 15 Transmitters

4. Component Parts

26 Amplifiers.

- 05 DC amplifiers
- 10 IF amplifiers
- 15 Magnetic amplifiers
- 20 Microwave amplifiers
- 25 RF amplifiers
- 30 Servo-types
- 35 TV amplifiers
- 40 TV boosters
- 45 Wide-band amplifiers

27 Antennas & Accessories.

- 05 All-wave receiving
- 10 Dummy
- 15 Feeder line
- 20 Indoor types
- 25 Insulators
- 30 Lightning arrestors
- 35 Mounting hardware
- 40 Small towers
- 45 TV multiple systems

28 Batteries.

- 05 Dry batteries
- 10 Mercury batteries
- 15 Storage batteries — lead-acid
- 20 Storage batteries — nickel-alkali
- 25 Storage batteries — silver-zinc

29 Blowers & Cooling Fans.

- 05 Air wheels & housings
- 10 Complete blower assemblies
- 15 Fan blades

30 Cabinets, Consoles, & Enclosures.

- 05 Metal cabinets
- 10 Metal relay rack panels
- 15 Moulded plastic cabinets
- 20 Wood cabinets

31 Capacitors: Fixed.

- 05 Ceramic
- 10 Electrolytic
- 15 High voltage

- 20 Metallized paper
- 25 Mica
- 30 Oil filled
- 35 Paper
- 40 Plastic insulated
- 45 Power factor
- 50 Precision air
- 55 Printed circuit
- 60 Pulse forming networks
- 65 Silvered mica
- 70 Tantalum
- 75 Vacuum

32 Capacitors: Variable.

- 05 Neutralizing
- 10 Precision variable
- 15 Temperature compensating
- 20 Trimmers, air
- 25 Trimmers, ceramic
- 30 Trimmers, glass
- 35 Trimmers, vacuum
- 40 Tuning

33 Chassis & Racks.

- 05 Aluminum chassis
- 10 Chassis slides
- 15 Relays racks & cabinets
- 20 Steel chassis

34 Coils.

- 05 Audio frequency chokes
- 10 Deflection yokes
- 15 Filter
- 20 Flyback
- 25 Focusing coils
- 30 RF & IF chokes
- 35 Toroids
- 40 Tuning

35 Connectors.

- 05 AN & MIL standard types
- 10 Co-axial
- 15 Microphone
- 20 Multiple circuit connectors
- 25 Power
- 30 Slip ring and commutating connectors
- 35 Sub-miniature

36 Converters.

- 05 AC to DC
- 10 DC to AC
- 15 Inverters
- 20 Rotary
- 25 Vibrators

37 Cores.

- 05 Ceramic
- 10 Ferrites
- 15 Pre-formed, spirally wound
- 20 Powdered metal
- 25 Toroids

38 Crystals & Accessories.

- 05 Crystal holders
- 10 Crystal ovens
- 15 Germanium
- 20 Oscillating quartz crystals
- 25 Piezo electric

39 Delay Lines.

- 05 Distributed constant
- 10 Distributed parameter
- 15 Lumped constant
- 20 Sonic

40 Filters.

- 05 Mechanical
- 10 Microwave
- 15 RF noise reduction
- 20 TV noise reduction
- 25 UHF & VHF

41 Fuses & Fuse Holders.

- 05 Fuses
- 10 Fuse holders

42 Magnets.

- 05 Electro
- 10 Permanent

43 Meters (Indicating Instruments).

- 05 Ammeters
- 10 Elapsed time
- 15 Frequency indicating
- 20 Galvanometers
- 25 Micro-ammeters
- 30 Milli-ammeters
- 35 Voltmeters
- 40 Volume level. (DB & VU)
- 45 Wattmeters & watt hour meters

44 Motors & Motor-Generators.

- 05 Blower & fan motors
- 10 Dynamotors
- 15 Frequency changers
- 20 Motor-generators
- 25 Phonograph
- 30 Servo
- 35 Synchronous motors
- 40 Timing motors

45 Pilot Lights & Assemblies.

- 05 Brackets, jewels, mounts, sockets
- 10 Incandescent lights
- 15 Neon lights

46 Power Supplies.

- 05 High voltage, (kilovolt)
- 10 Low voltage
- 15 Medium voltage
- 20 Primary power sources, fuel-engine driven
- 25 Voltage regulated power sources

47 Printed Circuits.

- 05 Etched or screened prewired chassis
- 10 Printed electronic assemblies
- 15 Solder dipped prewired chassis

48 Rectifiers, Metallic.

- 05 Copper oxide
- 10 Germanium
- 15 Selenium diodes
- 20 Selenium stacks
- 25 Silicon

49 Rectifiers, Vacuum Tube.

- 05 Grid controlled
- 10 Mercury vapor
- 15 Receiving
- 20 Transmitting

50 Relays.

- 05 Co-axial
- 10 D'Arsonval
- 15 Frequency selective
- 20 Hermetically sealed
- 25 Keying
- 30 Latching
- 35 Mercury contact
- 40 Polarized
- 45 Power control & overload
- 50 Stepping
- 55 Sub-miniature
- 60 Telephone
- 65 Time delay

51 Resistors.

- 05 Carbon fixed, moulded
- 10 Carbon, variable
- 15 Deposited carbon
- 20 Potentiometers
- 25 Printed circuit
- 30 Rhcostats
- 35 Vacuum sealed
- 40 Very high megohm
- 45 Wirewound, fixed
- 50 Wirewound, variable
- 55 Wirewound, precision

52 Semi-Conductors.

- 05 Germanium diodes
- 10 Transistors, junction
- 15 Transistors, point contact

53 Sockets.

- 05 Capacitor, plug-in sockets
- 10 Receiving tube
- 15 Transmitting tube
- 20 UL approved industrial types

54 Switches.

- 05 Band
- 10 Coaxial
- 15 Foot
- 20 Key
- 25 Mercury
- 30 Momentary contact
- 35 Power
- 40 Precision snap-acting
- 45 Rotary
- 50 Slide
- 55 Solenoids
- 60 Spring-return
- 65 Thermally operated
- 70 Toggle & push button

55 Telegraph Keys.

- 05 Manual
- 10 Mechanical high speed
- 15 Semi-automatic

56 Thermostats.

- 05 Bellows
- 10 Bimetal
- 15 Hermetically sealed

57 Transformers.

- 05 Audio
- 10 Geophysical
- 15 Hermetically sealed
- 20 Horizontal output & flyback
- 25 Isolation
- 30 Power components
- 35 Precision matched
- 40 Pulse
- 45 Radio Frequency
- 50 Saturable
- 55 TV deflection
- 60 TV impedance matching
- 65 Variable
- 70 Voltage regulating

58 Tuners.

- 05 AM tuners
- 10 FM tuners
- 15 Microwave
- 20 TV tuners
- 25 UHF & VHF

59 Vacuum Tubes, Receiving.

- 05 Cathode-ray & TV picture
- 10 Miniature
- 15 Standard types, glass & metal
- 20 Sub-miniature

60 Vacuum Tubes, Special Purpose.

- 05 Electrometer tubes
- 10 Geiger-Mueller
- 15 Phototubes
- 20 Pirani tubes
- 25 Thyratrons
- 30 Voltage regulators & ballasts

61 Vacuum Tubes, Transmitting.

- 05 ATR & TR types
- 10 Air-cooled power tubes
- 15 Iconoscopes
- 20 Image orthicons
- 25 Klystrons
- 30 Magnetrons
- 35 Monoscope tubes
- 40 Traveling wave
- 45 Water-cooled power tubes

62 Voltage Regulators.

- 05 Automatic
- 10 Manually operated
- 15 Varistors

5. Applications of Electronics, Industrial, Medical & Military.**63 Computers & Counters.**

- 05 Analog to digital converters
- 10 Computers, analog
- 15 Computers, digital
- 20 Counters, continuous
- 25 Counters, pre-set

64 Electronic Control Equip.

- 05 Burglar-alarm & protective systems
- 10 Combustion & smoke- nuisance controls
- 15 Electronic controls
- 20 Production control, counting & sorting equipment
- 25 Variable speed controls

65 Geophysical Apparatus.

- 05 Amplifiers
- 10 Complete exploration equipment
- 15 Control equipment
- 20 Microphones
- 25 Recording galvanometers

66 Induction Heating Equip.

- 05 Brazing, soldering & welding
- 10 Di-electric heating
- 15 Induction heating

67 Medical Equipment.

- 05 Cardiographs
- 10 Diathermy
- 15 Electronic cauterizing
- 20 Electro-encephalographs
- 25 Stimulators

68 Nuclear Equipment.

- 05 Pulse count integrators
- 10 Radiation detectors
- 15 Scalers

69 Servo-Mechanisms.

- 05 Controls
- 10 Gears, gear-trains, etc.
- 15 Servo amplifiers
- 20 Servo motors & generators

70 Telemetry Equipment.

- 05 Data recorders
- 10 Data storage mechanisms
- 15 FM/FM modulators

6. Radar, Microwave, UHF Equipment.**71 Antennas.**

- 05 Feed systems
- 10 Receiving
- 15 Reflectors
- 20 Rotating mechanisms
- 25 Transmitting

72 Receivers.

- 05 Microwave relay
- 10 Position indicators
- 15 Radar

73 Transmitters.

- 05 Microwave
- 10 Microwave relay
- 15 Radar

74 Waveguides & Accessories.

- 05 Couplings
- 10 Flexible waveguides

- 15 Hybrid junctions
- 20 Microwave attenuators
- 25 Rigid waveguides
- 30 Sampling lines, reflectors, etc.
- 35 Switches
- 40 Transmission lines

7. Materials, Fabricating Equipment & Services, Machinery & Tools, Contract Assemblers, Laboratories for Custom Built Equipment, Consulting Engineers.**75 Cable & Wire.**

- 05 Aluminum
- 10 Co-axial cables
- 15 Copper, bare
- 20 Low-loss, high-frequency types
- 25 Magnet wire
- 30 Precious & rare metals wire
- 35 Pre-formed wire harnesses
- 40 Rubber insulated
- 45 Shielded
- 50 Synthetic insulated
- 55 Wire mesh
- 60 Woven wire braid

76 Ceramics.

- 05 Coil forms
- 10 Custom fabrication
- 15 Insulators
- 20 Proprietary forms

77 Consulting Engineers.

- 05 Acoustical
- 10 Electrical
- 15 Mechanical
- 20 Radio

78 Core Materials.

- 05 Laminations
- 10 Metallic powders

79 Fabricators & Services.

- 05 Contract fabrication & assembly
- 10 Electro-plating
- 15 Embedment
- 20 Hardening & heat-treating
- 25 Hermetic sealing service
- 30 Metal stamping & spinning
- 35 Packaging
- 40 Plastic fabricators
- 45 Plastic moulders

80 Gases & Vapors.

- 05 Acetylene
- 10 Argon
- 15 Hydrogen
- 20 Krypton
- 25 Neon
- 30 Oxygen
- 35 Xenon

81 Hardware & Findings.

- 05 Adhesive labels & tapes
- 10 Bushings & bearings
- 15 Cans
- 20 Dials & dial assemblies
- 25 Flexible shafts
- 30 Gaskets
- 35 Grommets
- 40 Lacing cord & tape
- 45 Machine screw products
- 50 Nameplates
- 55 Paper preforms, for coil foundations
- 60 Retaining rings
- 65 Rivets
- 70 Screws, nuts & washers
- 75 Shock mounts
- 80 Springs

- 85 Strain reliefs
- 90 Terminal boards
- 95 Terminals, rivet or stud.
- 100 Terminals, wire end
- 105 Vibration mounts & isolating pads

82 Hermetic Seals.

- 05 Ceramic to metal seals
- 10 Complete headers
- 15 Glass to metal seals

83 Insulating Materials.

- 05 Cambric sheeting
- 10 Cambric tubing
- 15 Ceramic
- 20 Cotton tapes
- 25 Fiberglass tapes
- 30 Fiberglass tubing
- 35 Glass bonded mica
- 40 Plastic
- 45 RF shielding materials
- 50 Rubber
- 55 Synthetics

84 Laboratories & Custom Builders.

- 05 Individual item builders
- 10 Pilot run plants
- 15 Research & development labs.
- 20 Testing & certifying organizations

85 Lacquers, Paints, Compounds & Waxes.

- 05 Coil dope
- 10 Conducting paint
- 15 Finishing & protecting lacquer
- 20 Fungus preventatives
- 25 Moisture proofing
- 30 Sealing & potting compounds
- 35 Silicones

86 Machinery & Tools.

- 05 Coil winding machines
- 10 Dehydrators
- 15 General production machinery & tools
- 20 Marking & engraving machines
- 25 Soldering irons & guns
- 30 Vacuum tube machinery
- 35 Vacuum pumps
- 40 Vibration exciters
- 45 Welders & brazers

87 Metals.

- 05 Alloys
- 10 Copper
- 15 Ferrous
- 20 Non-ferrous, excluding copper
- 25 Powdered
- 30 Precious & rare

88 Moulded Products.

- 05 Insulators
- 10 Knobs & parts
- 15 Proprietary mouldings

89 Plastics.

- 05 Extrusions
- 10 Raw powders
- 15 Rods
- 20 Sheets
- 25 Tubes

90 Solder.

- 05 Acid core

- 10 Fluxes
- 15 Plain
- 20 Precious metal
- 25 Pre-forms
- 30 Rosin core

91 Vacuum Tube Parts.

- 05 Anodes
- 10 Envelopes, glass
- 15 Envelopes, metal
- 20 Getters
- 25 Grids & grid wire
- 30 Guns & gun parts
- 35 Phosphors
- 40 Pins & prongs
- 45 Spacers & insulators
- 50 Stampings
- 55 Tube caps
- 60 Tube clamps
- 65 Tube shields
- 70 Tubing-cathode

8. Test & Measuring Equipment, Laboratory Standards & Supplies.

92 Audio Frequency Test Equipment.

- 05 Beat frequency oscillators
- 10 Distortion & noise analyzers
- 15 Intermodulation meters
- 20 Output power meters
- 25 RC oscillators
- 30 Spectrum analyzers
- 35 Square wave generators
- 40 Voltmeters-audio frequency

93 General Laboratory Equipment & Supplies.

- 05 Chemicals
- 10 General laboratory equipment
- 15 RF shielding materials
- 20 Shielded enclosures

94 General Test Equipment.

- 05 Bridges, capacitance
- 10 Bridges, impedance
- 15 Bridges, inductance
- 20 Bridges, resistance
- 25 Decades, capacitance
- 30 Decades, resistance
- 35 Insulation testers
- 40 Multimeters
- 45 Ohm & megohm meters
- 50 Strain gauges
- 55 Stroboscopes
- 60 Transistor testers
- 65 Vacuum tube testers
- 70 Vacuum tube voltmeters
- 75 Vibration analyzers

95 Graphic Recorders.

- 05 Charts & papers
- 10 Ink writing
- 15 Inkless types
- 20 Fixed speed types
- 25 Variable speed types

96 Laboratory Standards of Frequency & Time.

- 05 Elapsed time measuring equip.
- 10 Primary standards of frequency

- 15 Primary standards of time
- 20 Secondary standards of frequency
- 25 Secondary standards of time
- 30 Tuning forks

97 Microwave & Radar Test Equipment.

- 05 Bolometers
- 10 Frequency meters
- 15 Marker generators
- 20 Oscillators
- 25 Pulse generators
- 30 Slotted lines & measuring accessories
- 35 SWR meters
- 40 Time delay generators
- 45 Wavemeters

98 Nuclear.

- 05 Dosimeters
- 10 Ionization chambers
- 15 Survey meters

99 Oscilloscopes—Cathode-Ray.

- 05 General purpose
- 10 Oscilloscope cameras
- 15 Oscillosynchrosopes
- 20 Recording oscillographs
- 25 Special UHF & pulse analysis equipment.

100 Radio Frequency Test Equipment.

- 05 Field strength meters
- 10 Impedance & admittance meters
- 15 Marker generators
- 20 Multi-vibrators
- 25 Phase meters
- 30 "Q" meters
- 35 RF power output meters
- 40 Signal generators, AM
- 45 Signal generators, FM
- 50 Sweep generators

101 Television Test Equipment.

- 05 Synchronizing generators
- 10 TV calibrators
- 15 TV marker generators
- 20 TV signal generators
- 25 TV sweep generators

9. Education & Publishing.

102 Education.

- 05 Technical instruction — home study
- 10 Technical instruction — resident

103 Publishing.

- 05 Book publishers
- 10 Data sheet & manual preparation
- 15 Magazines

10. Distributional Functions.

104 Distribution.

- 05 Export & Import
- 10 Jobbers & Wholesalers
- 15 Manufacturers Representatives
- 20 Sales & Service
- 25 Surplus dealers

LIST ADDITIONAL PRODUCTS BELOW

News—New Products

These manufacturers have invited PROCEEDINGS readers to write for literature and further technical information. Please mention your I.R.E. affiliation.

(Continued from page 159A)

High Resistance Bridge

Covering a range from 1,000,000 ohms to 100 megohms, the Model 601 Bridge developed by Shasta, div. of Beckman Instruments, Inc., P.O. Box 296, Station A, Richmond, Calif., measures resistance to an accuracy of better than 0.25 per cent. The circuit employed is a simple Wheatstone Bridge network with the unknown and a 10-turn Helipot potentiometer in adjacent legs. Bridge unbalance voltage is amplified by a vacuum-tube voltmeter and fed to a null indicating panel microammeter. The circuit is such that the meter cannot be damaged by severe unbalance conditions. At balance, resistance values correspond to Helipot dial settings multiplied by appropriate factor of 10.

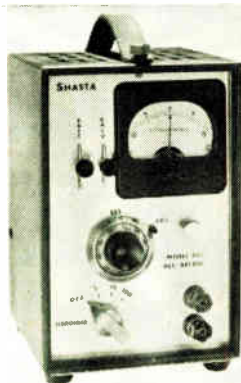

This instrument can be used in the laboratory for production testing of resistors, and for general-purpose resistance measurements. It is basically ac mains operated, but contains a 45 volts B battery for the bridge voltages for greater stability.

The Model 601 Bridge is housed in a miniature Shasta "A" cabinet.

Frankel New PA For CBS Columbia



M. A. Gardner, Vice President in charge of Purchases, of CBS-Columbia, the television receiver manufacturing division of Columbia Broadcasting System, announced today that Albert J. Frankel has been promoted to the position of Purchasing Agent.

(Continued on page 166A)

THIS BOOK DOESN'T

tell all



... but it's full of ideas you can use

SUCCESSFUL developments in the electronics field depend mainly on three things: ideas . . . experience . . . facilities. *This book is full of all three.*

Just a short request on your letterhead . . . or the coupon below . . . will bring this valuable book in the mail to you at once.

Thompson Products, Inc.

ELECTRONICS DIVISION • 2196 CLARKWOOD ROAD, CLEVELAND 3, OHIO

Thompson Products, Inc.
Dept. PI, Electronics Division
2196 Clarkwood Road, Cleveland 3, Ohio

Please send me a copy of Electronic Advancement.

Name _____ Title _____

Company _____

Address _____

City _____ Zone _____ State _____



INDEX AND DISPLAY ADVERTISERS

Meetings with Exhibits	2A
News and New Products	14A
Industrial Engineering Notes	82A
Professional Group Meetings	90A
Section Meetings	98A
Student Branch Meetings	105A
Membership	112A
Positions Open	130A
Positions Wanted by Armed Forces Veterans	136A

DISPLAY ADVERTISERS

Acme Electric Corp.	150A
Advance Electric & Relay Co.	117A
Advance Electronics Co.	151A
Aerovox Corp.	112A
Aircraft Radio Corp.	87A
Airtron, Inc.	111A
Airtron, Inc. (Emp.)	145A
Alden Products Co.	157A
Allen-Bradley Co.	20A
Allied Radio Corp.	106A
American Electric Motors	155A
American Lava Corp.	67A
American Phenolic Corp.	108A
American Television & Radio Co.	71A
Ampex Corp.	77A
Andrew Corp.	115A
Apex Coated Fabrics, Inc.	111A
Arnold Engineering Co.	44A
Assembly Products, Inc.	74A
Automatic Manufacturing Corp.	41A
Ballantine Laboratories, Inc.	60A
Barber Laboratories, Alfred W.	153A
Bardwell & McAlister, Inc.	84A
Bell Telephone Laboratories	4A
Bendix Aviation Corp. (Pacific Div.)	49A
Bendix Aviation Corp. (Radio Div.)	132A
Bendix Aviation Corp. (York Div.)	144A
Berkeley, Div. Beckman Instruments	113A
Bodnar Industries Inc.	154A
Bogue Electric Mfg. Co.	70A
Borg Equipment Div. (Geo. W. Borg Corp.)	42A
Bradley Laboratories, Inc.	104A
Brush Electronics Co. (Bruehl & Kjaer)	99A
Brush Electronics Co. (Magnetic Comp.)	150A
Buggie, Inc., H. H.	126A
Bussmann Manufacturing Co.	5A
Cambridge Thermionic Corp.	30A
Cannon Electric Co.	107A
Cargo Packers, Inc.	87A
Carter Motor Co.	158A
Centralab (Div. of Globe Union)	99A
Chatham Electronics Corp.	63A
Chicago Standard Transformer Corp.	117A
Clare & Co., C. P.	37A
Cohn Manufacturing Co., Inc., Sigmund	24A
Collins Radio Co.	59A
Communication Products Co.	111A
Communications Equipment Co.	160A
Conrad & Moser	121A
Cons. Vultee Aircraft Corp. (Convair)	139A
Content, Edward J.	153A
Cornell Aeronautical Laboratory, Inc.	148A
Cornell-Dubilier Electric Co.	Cov. 111
Cosmic Radio Corp.	118A
Crosby Laboratories, Inc.	153A
Crucible Steel Co. of America	69A
Dale Products, Inc.	24A
Dalmo Victor, Inc.	36A
Daven Co.	15A
Designers for Industry, Inc.	133A
Diamond Manufacturing Corp.	56A
Du Mont Laboratories, Inc., Allen B. (Trans. Div.)	46A & 47A
Dynamic Electronics-N.Y., Inc.	153A

You **KNOW** Your Tubes Are Tested when you use the

PRECISION SERIES 10-12 Electronamic TUBE PERFORMANCE TESTER with 12 ELEMENT free-point Master Lever Selector System

To test modern tubes for only one characteristic will not necessarily reveal overall performance capabilities. Tube circuits look for more than just Mutual Conductance or other single factor.

In the Precision Electronamic Circuit, the tube PERFORMS under appropriately phased and selected individual element potentials, encompassing a wide range of plate family characteristic curves. This complete Path of Operation is integrated by the indicating meter in the positive PERFORMANCE terms of Replace-Weak-Good.

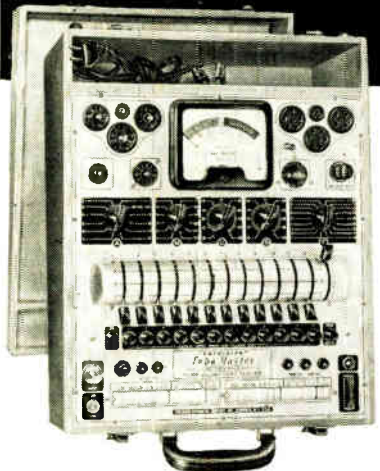

MODEL 10-12-P: in sloping, portable hardwood case with tool compartment and hinged removable cover. Size 13 3/4" x 17 1/4" x 6 3/4". . . \$107.50
Also in counter or rack-panel mounts.

- ★ Facilities to 12 element prongs.
- ★ Filament voltages from 3/4 to 117 volts.
- ★ Tests Noval 9 pins; 5 and 7 pin acorns; double-capped H.F. amplifiers; low power transmitting tubes; etc. Regardless of filament or any other element pin positions.
- ★ Isolates each tube element regardless of multiple pin positions.
- ★ Dual short check sensitivity provides for special purpose tube selection.
- ★ Battery Tests made under dynamic load conditions.
- ★ Built-in Dual-Window, geared roller chart.
- ★ 4 1/2" Full Vision PACE Meter.

See Model 10-12 and other Precision electronic test instruments at leading radio parts distributors. Write for new, 1954 catalog.

Precision Apparatus Co., Inc.

92-27 HORACE HARDING BLVD. • ELMHURST 12, N. Y.

Export: 458 B'way, N.Y.C., U.S.A. Cables: MORHANEX
In Canada: Atlas Radio Corp. Ltd., Toronto, Ontario

News—New Products

These manufacturers have invited PROCEEDINGS readers to write for literature and further technical information. Please mention your I.R.E. affiliation.

(Continued from page 165A)

Electron Tube Reliability

A 97-page report entitled "Investigation of Electron Tube Reliability in Military Applications" has just been published by Aeronautical Radio, Inc., (ARINC), a non-profit organization currently conducting an extensive study of military electronic tube reliability for the Army, Navy, and Air Force under a Bureau of Ships contract.

The report covers the period from April 4, 1951 through March 31, 1953, and describes the scope of the ARINC surveillance program, the methods of tube collection and of engineering and statistical analysis, and the result of the program to date. It contains a discussion of the characteristic defect patterns of tube returns from each of the eight military bases under surveillance and an analysis of each of the 20 individual tube types ranking highest in number of tubes returned. There is also an evaluation of tube weaknesses, unreliability, such as environment, operating procedures, misapplications, and maintenance. Incorporated in the report are 65 tables, 24 charts, and photographs, and a statistical appendix.

The report is available for 50¢ from L. E. Davis, Aeronautical Radio, Inc., 1523 "L" St., N.W., Washington 5, D. C.

Audio Oscillator

The model 411 oscillator, manufactured by The Clough-Bregle Co., 6041 Broadway, Dept. P, Chicago 40, Ill., is suitable for making measurements requiring a sine wave signal over the range from 20 cps to 1 mc.

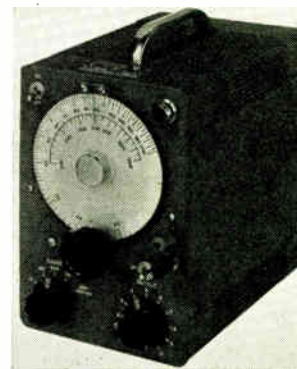

A resistance-capacity tuned-type oscillator and a cathode follower in the output system are employed to provide uniform response. Frequency accuracy is maintained by the use of deposited carbon resistors in the frequency determining network. Low-level measurements are facilitated by a panel switch which reduces output voltage, distortion and hum output. Other features of the Model 411 are good case ventilation, a well spread dial calibration for ease in reading, and compact size with light weight. For additional information write to The Clough-Bregle Co.

(Continued on page 167A)

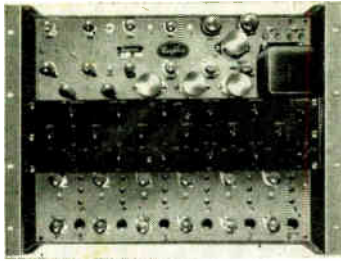

Model MBG-1 MULTI-BURST GENERATOR

A new video test signal generator for quick and accurate frequency response checks of complete television systems, distribution networks, or components. Individual oscillators provide 13 discrete bursts of sinusoidal frequencies from 0.5 to 6.0 mc, in six overlapping ranges. Produces any six frequencies simultaneously. Adjustable sync pulse, blanking pedestal, and white reference level. Write for additional information. Data on other color tv instruments available on request.

Wicker ENGINEERING AND CONSTRUCTION COMPANY

12TH STREET AND FERRY AVENUE

ESTABLISHED 1920

CAMDEN 4, NEW JERSEY

News—New Products

These manufacturers have invited PROCEEDINGS readers to write for literature and further technical information. Please mention your I.R.E. affiliation

(Continued from page 166A)

Miller New Field Engineer for General Plate

O. V. (Jack) Miller has been named field engineer for the Wisconsin-Minnesota area by the General Plate Div. of Metals & Controls Corp., Attleboro, Mass.



His new duties will include application engineering of General Plate products: electrical contacts and contact materials, Truflex thermostat metals and fabricated parts, solid and composite precious metals, composite base metals, and other related products.

Tollaksen Moves to Remler



The appointment of Leslie B. Tollaksen as manager of technical products by Remler Company, Ltd., San Francisco electronics manufacturer, has been announced by R. C. Gray, president. Tollaksen's headquarters will be the Remler office in the Wyatt Bldg., Washington, D. C.

Coming 1954 IRE DIRECTORY about September 25th

**Mueller
MAKES THE CLIPS!
ALL TYPES—ALL SIZES
at jobbers everywhere**

Wee-Pee-Wee
Clips



Pee-Wee Clips



Alligator Clips



Crocodile Clips



Shown in typical
flexible insulator

Needle Clips



Test Clips



SAMPLE BOARD

**SEND FOR FREE CLIP &
INSULATOR SAMPLES!**

Pick from illustrations above.

5 INSULATOR COLORS now available for easy lead identification. Black, Red, White, Blue and Yellow. Samples furnished on request.

NEW CATALOG No. Y563
ON REQUEST

Mueller Electric Co.
1563Y EAST 31st STREET • CLEVELAND 14, OHIO

Ask about handy, low cost display and selection board, for department heads, jobbers, etc.

DISPLAY ADVERTISERS

Eby, Inc., Hugh H.	128A
Eitel-McCullough, Inc.	6A, 68A
Elco Corp.	94A
Eldico of New York, Inc.	153A
Electra Mfg. Co.	116A
Electrical Industries	125A
Electro Motive Manufacturing Co., Inc.	65A
Electro-Pulse, Inc.	126A
Electro-Search	153A
Electronic Associates, Inc.	76A
Electronic Engineering Co. of Calif.	143A
Elk Electronics Laboratories, Inc.	153A
Empire Devices Products Corp.	122A
Engineering Associates	118A
Engineering and Research Corp.	132A
Engineering Research Assoc., Inc.	134A
Erie Resistor Corp.	79A

Fairchild Camera & Instrument Corp. (Potentiometer)	90A
Ford Instrument Co. (Empl.)	146A
Frederick Research Corp.	153A
Freed Transformer Co., Inc.	73A
Frequency Standards	32A
Fugle-Miller Laboratories	110A
Furst Electronics	86A

Gabriel Electronics Div.	107A
General Ceramics Corp.	11A
General Electric Co. (Apparatus Div.)	16A & 17A, 92A & 93A
General Electric Co. (Empl.)	143A
General Electric Co. (Germanium Diodes)	31A
General Instrument Corp.	134A
General Precision Laboratory, Inc.	141A
General Radio Co.	Cov. IV
Giannini & Co., G. M.	83A
Giffillan Brothers, Inc.	138A, 144A
Godley Co., Paul	153A
Goodyear Aircraft Corp.	143A
Gordon Associates	153A
Grant Pulley & Hardware Co.	119A
Graphite Metallizing Corp.	158A
Guardian Electric Mfg. Co.	35A

Haller, Raymond and Brown, Inc.	153A
Harvey Radio Co., Inc.	94A
Heiland Research Corp.	78A
Helipot Corp.	81A
Heppner Manufacturing Co.	124A
Hermetic Seal Products Co.	154A
Hewlett-Packard Co.	101A
Hoffman Laboratories, Inc.	141A
Hogan Laboratories, Inc.	153A
Hughes Aircraft Co.	27A
Hughes Research & Dev. Labs.	130A & 139A
Hycor Sales Co. of Calif.	98A

Indiana Steel Products Co.	48A
Institute of Radio Engineers	2A, 3A, 12A & 13A, 54A, 60A, 161A, 162A, 163A & 164A
International Rectifier Corp.	7A
International Resistance Co.	38A & 39A

Jennings Radio Manufacturing Co.	72A
Johns Hopkins Laboratories (Appl. Physics Lab.)	136A
Johnson Co., E. F.	155A
Jones Div., Howard B., (Cinch Mfg. Corp.)	100A

Kahle Engineering Co.	26A
Kahn, Leonard R.	153A
Kay Electric Co.	103A
Kearfott Co., Inc.	88A
Kenyon Transformer Co., Inc.	10A
Kings Electronics Co., Inc.	33A
Knights Co., James	123A
Kollsman Instrument Corp. (Empl.)	146A

Langevin Manufacturing Corp.	3A
Lapp Insulator Co., Inc.	96A
Lavoie Laboratories, Inc.	55A
Litton Engineering Laboratories	34A
Lockheed Aircraft Corp. (Missile Systems Div.)	147A, 149A

Magnavox Co., The	135A
Magnetics, Inc.	75A
Mallory & Co., Inc., P. R.	8A, 91A
Marion Electrical Instrument Co.	21A
Mass. Inst. of Technology (Dig. Comp. Lab.)	145A
Maxson Corp., W. L.	52A
Maxson Corp., W. L. (Empl.)	145A
McColpin-Christie Corp.	127A
McCoy Electronics Co.	95A
McDonnell Aircraft Corp.	132A
McKay Electric Co.	153A

Improved 20 to 40,000 cycle Beat-Frequency Oscillator with Unusual Stability



Type 1304-B
Beat-Frequency
Oscillator \$555.00



NEW!

Type 908-P
Synchronous Motor
Dial Drive

shown attached to Type 1304-B Beat-Frequency Oscillator

The newly announced Type 1304-B Beat-Frequency Oscillator is a better than ever general-purpose laboratory signal-source. It succeeds the Type 1304-A, keeping pace with improvements in techniques.

The 1304-B extends the frequency range to 40 kc . . . has a meter as well as a calibrated attenuator in the output stage . . . has minimum harmonic distortion . . . and incorporates improvements in circuitry and components which make for unusual stability and constancy of output voltage over the frequency range. Many operating conveniences are incorporated in this instrument to facilitate specialized audio-frequency measurements.

**An Even More Versatile Research and Development Tool
than its Already Extremely Popular Predecessor**

Unusual Stability . . . frequency drift is less than 7 cycles in the first hour from a cold start; essentially complete within two hours

True Logarithmic Frequency Scale . . . precisely calibrated from 20 to 20,000 cycles . . . accuracy is within $\pm(1\% + 0.5 \text{ cycle})$. . . 20 kc added by range switch accurate within $\pm 0.5\%$. . . logarithmic scale permits work with recorders to plot frequency characteristics directly

-50 to +50 Cycle Increment Dial . . . a great convenience . . . permits successive frequency settings within ± 1 cycle of preceding setting

Output Voltage . . . full scale, open-circuit voltages of 50 mv, 500 mv, 5 and 50 volts

Constant Output Voltage Over Range . . . output varies less than $\pm 0.25 \text{ db}$ from 20 to 20,000 cycles, when working into matched load; less than $\pm 1 \text{ db}$ to 40 kc

Minimum Harmonic Distortion . . . less than 0.25% distortion from 100 to 10,000 cycles, 0.5% at 50 cycles, and no more than 1% above 10 kc

With this unique drive, any desired portion of the oscillator frequency range is automatically swept in repetitive cycles. Installing takes but a minute. The unit operates from 115-volt, 60-cycle power. When done, a flip of a switch disengages the drive from the oscillator shaft.

Oscillators equipped with this drive can be used with recording equipment to record conveniently and automatically the frequency response of the network under study.

When used with logarithmic frequency dial of Type 1304-B Beat-Frequency Oscillator . . .

Type 908-P1 Drive—takes 50 sec to cover one-frequency decade, or 15 sec/octave

Type 908-P2 Drive—6-2/3 sec per frequency decade, or 2 sec/octave

Prices Available on Request

Read The JUNE issue of the "Experimenter"
for a Complete Description of the
new Type 1304-B Beat-Frequency Oscillator

General Radio Co., 275 Mass. Ave., Cambridge 39, Mass.
Please send copy of June 1954 G-R EXPERIMENTER
describing the Type 1304-B Beat-Frequency Oscillator.

Name 587

Company

Street

City Zone State



GENERAL RADIO Company
275 Massachusetts Avenue, Cambridge 39, Massachusetts, U. S. A.
90 West St. NEW YORK 6 920 S. Michigan Ave. CHICAGO 5 1000 H. Seward St. LOS ANGELES 78

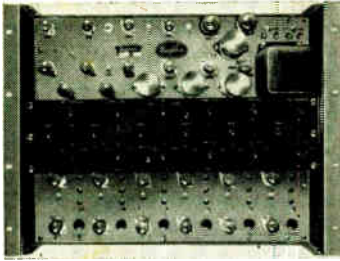

Model MBG-1 MULTI-BURST GENERATOR

A new video test signal generator for quick and accurate frequency response checks of complete television systems, distribution networks, or components. Individual oscillators provide 13 discrete bursts of sinusoidal frequencies from 0.5 to 6.0 mc, in six overlapping ranges. Produces any six frequencies simultaneously. Adjustable sync pulse, blanking pedestal, and white reference level. Write for additional information. Data on other color tv instruments available on request.

Wickers ENGINEERING AND CONSTRUCTION COMPANY

ESTABLISHED 1920

12TH STREET AND FERRY AVENUE

CAMDEN 4, NEW JERSEY

News—New Products

These manufacturers have invited PROCEEDINGS readers to write for literature and further technical information. Please mention your I.R.E. affiliation

(Continued from page 166A)

Miller New Field Engineer for General Plate

O. V. (Jack) Miller has been named field engineer for the Wisconsin-Minnesota area by the General Plate Div. of Metals & Controls Corp., Attleboro, Mass.



His new duties will include application engineering of General Plate products: electrical contacts and contact materials, Truflex thermostat metals and fabricated parts, solid and composite precious metals, composite base metals, and other related products.

Tollaksen Moves to Remler



The appointment of Leslie B. Tollaksen as manager of technical products by Remler Company, Ltd., San Francisco electronics manufacturer, has been announced by R. C. Gray, president. Tollaksen's headquarters will be the Remler office in the Wyatt Bldg., Washington, D. C.

Coming 1954 IRE DIRECTORY about September 25th

Mueller MAKES THE CLIPS! ALL TYPES—ALL SIZES at jobbers everywhere

Wee-Pee-Wee
Clips



Pee-Wee Clips



Alligator Clips



Crocodile Clips



Shown in typical
flexible insulator

Needle Clips



Test Clips



SAMPLE BOARD

SEND FOR FREE CLIP & INSULATOR SAMPLES!

Pick from illustrations above.

5 INSULATOR COLORS now available for easy lead identification. Black, Red, White, Blue and Yellow. Samples furnished on request.

NEW CATALOG No. Y563
ON REQUEST

Ask about handy, low cost display and selection board, for department heads, jobbers, etc.

Mueller Electric Co.

1563Y EAST 31st STREET • CLEVELAND 14, OHIO

DISPLAY ADVERTISERS

Eby, Inc., Hugh H.	128A
Eitel-McCullough, Inc.	6A, 68A
Elco Corp.	94A
Eldico of New York, Inc.	153A
Electra Mfg. Co.	116A
Electrical Industries	125A
Electro Motive Manufacturing Co., Inc.	65A
Electro-Pulse, Inc.	126A
Electro-Search	153A
Electronic Associates, Inc.	76A
Electronic Engineering Co. of Calif.	143A
Elk Electronics Laboratories, Inc.	153A
Empire Devices Products Corp.	122A
Engineering Associates	118A
Engineering and Research Corp.	132A
Engineering Research Assoc., Inc.	134A
Erie Resistor Corp.	79A

Fairchild Camera & Instrument Corp. (Potentiometer)	90A
Ford Instrument Co. (Empl.)	146A
Frederick Research Corp.	153A
Freed Transformer Co., Inc.	73A
Frequency Standards	32A
Fugle-Miller Laboratories	110A
Furst Electronics	86A

Gabriel Electronics Div.	107A
General Ceramics Corp.	111A
General Electric Co. (Apparatus Div.)	11A
General Electric Co. (Empl.)	16A & 17A, 92A & 93A
General Electric Co. (Germanium Diodes)	143A
General Instrument Corp.	31A
General Precision Laboratory, Inc.	134A
General Radio Co.	141A
Giannini & Co., G. M.	Cov. IV
Giffillan Brothers, Inc.	83A
Godley Co., Paul	138A, 144A
Goodyear Aircraft Corp.	153A
Gordon Associates	143A
Grant Pulley & Hardware Co.	153A
Graphite Metallizing Corp.	119A
Guardian Electric Mfg. Co.	158A
	35A

Haller, Raymond and Brown, Inc.	153A
Harvey Radio Co., Inc.	94A
Heiland Research Corp.	78A
Helipot Corp.	81A
Heppner Manufacturing Co.	124A
Hermetic Seal Products Co.	154A
Hewlett-Packard Co.	101A
Hoffman Laboratories, Inc.	141A
Hogan Laboratories, Inc.	153A
Hughes Aircraft Co.	27A
Hughes Research & Dev. Labs.	130A & 139A
Hycor Sales Co. of Calif.	98A

Indiana Steel Products Co.	48A
Institute of Radio Engineers	2A, 3A, 12A & 13A, 54A, 60A, 161A, 162A, 163A & 164A
International Rectifier Corp.	7A
International Resistance Co.	38A & 39A

Jennings Radio Manufacturing Co.	72A
Johns Hopkins Laboratories (Appl. Physics Lab.)	136A
Johnson Co., E. F.	155A
Jones Div., Howard B., (Cinch Mfg. Corp.)	100A

Kahle Engineering Co.	26A
Kahn, Leonard R.	153A
Kay Electric Co.	103A
Kearfott Co., Inc.	88A
Kenyon Transformer Co., Inc.	10A
Kings Electronics Co., Inc.	33A
Knights Co., James	123A
Kollsman Instrument Corp. (Empl.)	146A

Langevin Manufacturing Corp.	3A
Lapp Insulator Co., Inc.	96A
Lavoie Laboratories, Inc.	55A
Litton Engineering Laboratories	34A
Lockheed Aircraft Corp. (Missile Systems Div.)	147A, 149A

Magnavox Co., The	135A
Magnetics, Inc.	75A
Mallory & Co., Inc., P. R.	8A, 91A
Marion Electrical Instrument Co.	21A
Mass. Inst. of Technology (Dig. Comp. Lab.)	145A
Maxson Corp., W. L.	52A
Maxson Corp., W. L. (Empl.)	145A
McColpin-Christie Corp.	127A
McCoy Electronics Co.	95A
McDonnell Aircraft Corp.	132A
McKay Electric Co.	153A

DISPLAY ADVERTISERS

Measurements Corp.	100A, 118A
Melpar, Inc.	136A
Microwave Consultants	153A
Microwave Development Labs., Inc.	153A
Midland Manufacturing Co., Inc.	61A
Millen Manufacturing Co., Inc., James	120A
Mueller Electric Co.	167A
Mullenbach Electrical Manufacturing Co.	89A
Mycalex Corp. of America	121A
N.R.K. Manufacturing & Engineering Co.	154A
Nassau Research & Development Assoc. Inc.	106A
Naybor, E. V.	153A
New London Instrument Co.	52A
Norden Laboratories Corp.	147A
Ostlund, Evert, M.	153A
Panoramic Radio Products, Inc.	156A
Paramount Paper Tube Corp.	102A
Par-Metal Products Corp.	126A
Pickard & Burns, Inc.	153A
Polarad Electronics Corp.	43A
Polytechnic Research & Development Co., Inc.	123A
Ponder & Best, Inc.	113A
Potter & Brumfield	120A
Precision Apparatus Co., Inc.	166A
Precision Paper Tube Co.	66A
Pyramid Electric Co.	102A
Radiation, Inc.	129A
Radio Corp. of America (Empl.)	131A
Radio Corp. of America (Tubes Designer)	80A
Radio Materials Corp.	57A
Raytheon Manufacturing Co. (Empl.)	141A
Raytheon Manufacturing Co. (Power Tubes)	58A
Raytheon Manufacturing Co. (Rec. Tubes)	23A
Republic Aviation Corp.	149A
Resinite Corp.	122A
Resistance Products Co.	152A
Riesler & Thesmacher Co.	103A
Rosenberg Associates, Paul	153A
Rutherford Electronics Co.	159A
Sanborn Co.	9A
Sanders Associates, Inc.	146A
Sandia Corp.	137A
Secon Metals Corp.	110A
Servo Corp. of America	159A
Simpson Electric Co.	105A
Sola Electric Co.	22A
Sorensen & Co., Inc.	82A
Speer Resistor Div., Speer Carbon Co.	62A
Sperry Gyroscope Co. (Empl.)	142A
Sperry Gyroscope Co.	109A
Sprague Electric Co.	1A
Sprague Electric Co. (Resistor Div.)	97A
Stackpole Carbon Co.	53A
Standard Piezo Co.	86A
Staviv Engineering, Inc.	142A
Stoddard Aircraft Radio Co.	2A, 91A
Stupakoff Ceramic & Manufacturing Co.	85A
Superior Electric Co.	25A
Superior Tube Co.	50A
Switchcraft, Inc.	152A
Sylvania Electric Products, Inc.	19A
Sylvania Electric Products Inc. (Woburn Empl.)	137A
Sylvania Electric Products, Inc. (Empl.)	140A
Synthane Corp.	51A
Technology Instrument Corp.	40A
Tektronix, Inc.	83A
Telrex, Inc.	153A
Texas Instruments, Inc.	29A
Thompson Products, Inc.	165A
Transradio, Ltd.	98A
Triad Transformer Corp.	26A
Truscon Steel Div., Republic Steel	64A
Tung-Sol Electric, Inc.	138A
United States Gasket Co.	168A
United Transformer Co.	Cov. II
Varian Associates	71A
Victoreen Instrument Co.	28A
Waveline, Inc.	89A
Western Gold & Platinum Works	114A
Westinghouse Electric Corp. (Empl.)	135A
Weston Electrical Instrument Corp.	18A
Wheeler Laboratories, Inc.	114A, 153A
White Dental Manufacturing Co., S. S.	157A
White-Rodgers Electric Co.	148A
Wickes Eng. & Construction Co.	167A
Wilcox Electric Co., Inc.	45A
Wilcox Electric Co., Inc. (Empl.)	142A
Zophar Mills, Inc.	123A

flower of the Engineered Plastics

TEFLON and KEL-F

Electrically—The finest insulating materials known for VHF, UHF and microwave circuits operating in wide range of ambient temperatures and pressure altitudes to 80,000 feet.

Chemically—The only materials that are inert to all chemicals except molten alkali metals, fluorine under pressure and chlorine trifluoride.

Physically—The most anti-hesive material known, as well as tough, resilient, wear resistant.

But to gain all their outstanding advantages, these materials must be handled "just right" in their fabrication.

The United States Gasket Company offers "Knowhow", based on long experience—specialized facilities—and close Quality Control "from powder to part" to assure you TEFLON and KEL-F at their best.

Stock includes sheets, rods, tubing, tape, bars, cylinders, beading, and extruded shapes (the most complete line in the country).

Precision molded and machined parts are produced to customers' specifications.

Ask for Bulletins No. 300 and No. 500.

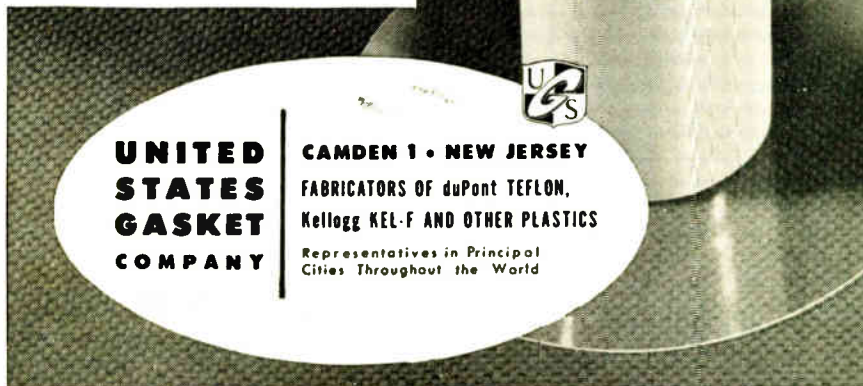



UNITED STATES GASKET COMPANY

CAMDEN 1 • NEW JERSEY

FABRICATORS OF duPont TEFLON, Kellogg KEL-F AND OTHER PLASTICS

Representatives in Principal Cities Throughout the World

Consistently Dependable

Cornell-Dubilier

electrolytic capacitors



**Whether you order 1 or 1,000,000
you can rely on C-D electrolytics.**

The consistent demand for C-D, year after year, by the country's leading manufacturers is proof of the uniform quality of C-D ELECTROLYTICS. Whatever your ELECTROLYTIC requirement you will find that Cornell-Dubilier's consistent dependability is unmatched in the field—even to the new, real small (miniature) ELECTROLYTICS.

Engineering samples sent on request. For your special design and application problems, use our Technical Advisory Service. Write to:

*Cornell-Dubilier Electric Corp., Dept. M54
South Plainfield, New Jersey.*

THERE ARE MORE C-D CAPACITORS IN USE TODAY THAN ANY OTHER MAKE

CORNELL DUBILIER *Capacitors*



PLANTS IN SOUTH PLAINFIELD, N. J.; NEW BEDFORD, WORCESTER AND CAMBRIDGE, MASS.; PROVIDENCE AND HOPE VALLEY, R. I.; INDIANAPOLIS, IND.; FUGUAY SPRINGS AND SANFORD, N. C.; AND SUBSIDIARY, THE RADIART CORPORATION, CLEVELAND, OHIO



ANTENNAS



ROTORS



CAPACITORS



VIBRATORS



CONVERTERS

Improved 20 to 40,000 cycle Beat-Frequency Oscillator with Unusual Stability



Type 1304-B
Beat-Frequency
Oscillator \$555.00

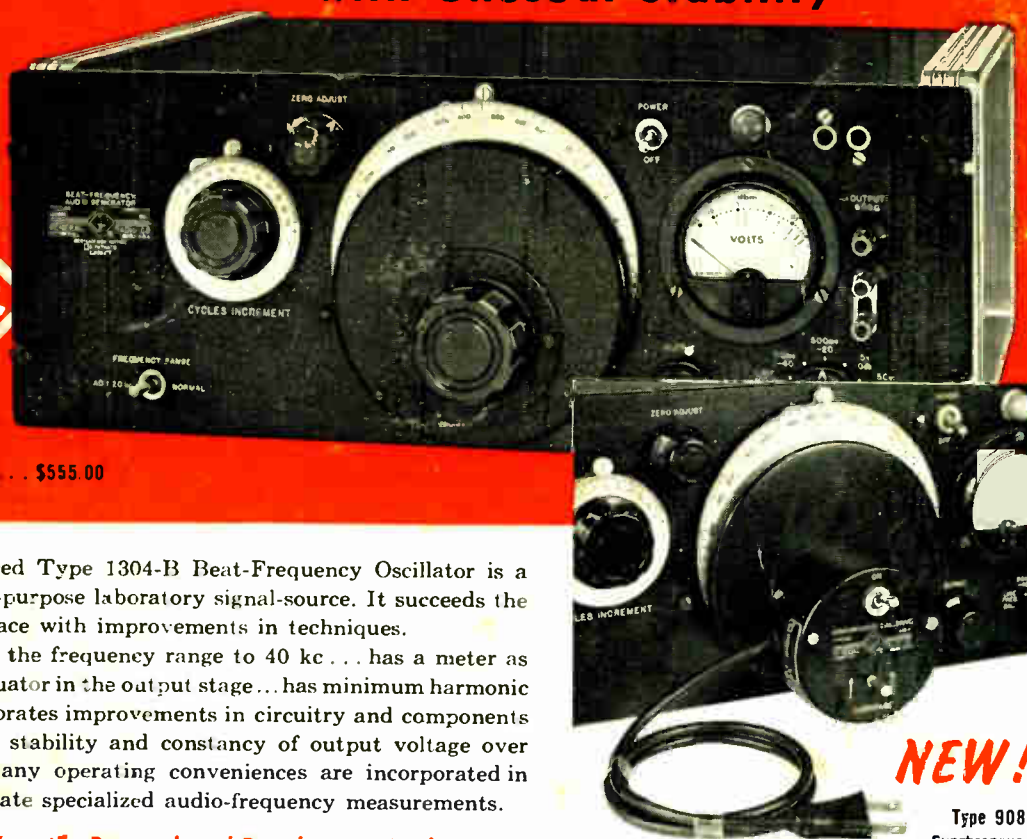

NEW!

Type 908-P
Synchronous Motor
Dial Drive

shown attached to Type 1304-B Beat-Frequency Oscillator

The newly announced Type 1304-B Beat-Frequency Oscillator is a better than ever general-purpose laboratory signal-source. It succeeds the Type 1304-A, keeping pace with improvements in techniques.

The 1304-B extends the frequency range to 40 kc . . . has a meter as well as a calibrated attenuator in the output stage . . . has minimum harmonic distortion . . . and incorporates improvements in circuitry and components which make for unusual stability and constancy of output voltage over the frequency range. Many operating conveniences are incorporated in this instrument to facilitate specialized audio-frequency measurements.

**An Even More Versatile Research and Development Tool
than its Already Extremely Popular Predecessor**

Unusual Stability . . . frequency drift is less than 7 cycles in the first hour from a cold start; essentially complete within two hours

True Logarithmic Frequency Scale . . . precisely calibrated from 20 to 20,000 cycles . . . accuracy is within $\pm(1\% + 0.5 \text{ cycle})$. . . 20 kc added by range switch accurate within $\pm 0.5\%$. . . logarithmic scale permits work with recorders to plot frequency characteristics directly

-50 to +50 Cycle Increment Dial . . . a great convenience . . . permits successive frequency settings within ± 1 cycle of preceding setting

Output Voltage . . . full scale, open-circuit voltages of 50 mv, 500 mv, 5 and 50 volts

Constant Output Voltage Over Range . . . output varies less than ± 0.25 db from 20 to 20,000 cycles, when working into matched load; less than ± 1 db to 40 kc

Minimum Harmonic Distortion . . . less than 0.25% distortion from 100 to 10,000 cycles, 0.5% at 50 cycles, and no more than 1% above 10 kc

With this unique drive, any desired portion of the oscillator frequency range is automatically swept in repetitive cycles. Installing takes but a minute. The unit operates from 115-volt, 60-cycle power. When done, a flip of a switch disengages the drive from the oscillator shaft.

Oscillators equipped with this drive can be used with recording equipment to record conveniently and automatically the frequency response of the network under study.

When used with logarithmic frequency dial of Type 1304-B Beat-Frequency Oscillator . . .

Type 908-P1 Drive—takes 50 sec to cover one-frequency decade, or 15 sec/octave

Type 908-P2 Drive—6-2/3 sec per frequency decade, or 2 sec/octave

Prices Available on Request

Read The JUNE issue of the "Experimenter"
for a Complete Description of the
new Type 1304-B Beat-Frequency Oscillator

General Radio Co., 275 Mass. Ave., Cambridge 39, Mass.
Please send copy of June 1954 G-R EXPERIMENTER
describing the Type 1304-B Beat-Frequency Oscillator.

Name 587

Company

Street

City Zone State



GENERAL RADIO Company
275 Massachusetts Avenue, Cambridge 39, Massachusetts, U. S. A.
90 West St. NEW YORK 6 920 S. Michigan Ave. CHICAGO 5 1000 N. Seward St. LOS ANGELES 33