

IEEE spectrum

features

- 39** Spectral lines: Importance of secondary publications
Since World War II the number of technical pages published has been increasing at a rate of some 10 percent per year, thus doubling in number in less than eight years
- + 43** Plasmas in space Morton A. Levine
Through a cooperative scientific attack, the true picture of the interaction of the solar wind with the magnetosphere of the earth is slowly beginning to unfold
- + 48** Solid-state HV dc transmission technology F. D. Kaiser
Recent solid-state HV dc accomplishments include the development of several proved means to gate and control a series string of thyristors throughout a full range of control angles
- + 52** Trends in digital communication by wire R. H. Franklin, H. B. Law
A few years of production of 24-channel PCM systems to current standards may set a pattern that will determine future expansion of a digital network for all purposes and for all distances
- + 59** Ocean engineering: food fish for a hungry world Gordon D. Friedlander
The present yearly catch of food fish can probably be multiplied ten times—with the aid of electronics—without endangering the total edible marine population
- + 73** Insulated sodium conductors—a future trend
 L. E. Humphrey, R. C. Hess, G. I. Addis, A. E. Ruprecht, P. H. Ware,
 E. J. Steeve, J. A. Schneider, I. F. Matthyse, E. M. Scoran
One kilogram of sodium, costing \$0.38, will conduct as much electric current as 3.25 kg of copper, costing about \$2.56
- + 82** Communications—concept and reality W. Deming Lewis
Leonardo da Vinci was probably the last man of whom it could be said that his knowledge encompassed all the learning of his era
- + 85** A nonmagnetic laboratory for the National Bureau of Standards
 Forest K. Harris
It is hoped that the new NBS nonmagnetic facility will make it possible to improve the accuracy of our absolute-ampere measurements—perhaps contributing to a better international assignment of the volt
- + 88** M.I.T.-NASA Working Conference on Manual Control
 Laurence R. Young, Roger Winblade
- 40** Authors
 Departments: *please turn to the next page*



THE INSTITUTE OF ELECTRICAL AND ELECTRONICS ENGINEERS, INC.

departments

- 9 Transients and trends
- 10 IEEE forum
- 12 News of the IEEE
- Managers meet to study new approaches to problems, increase management effectiveness..... 12
 - Nominees sought for IEEE awards, medals, prizes..... 12
 - Program announced for Montreal G-VC conference..... 14
 - Engineers join IEEE despite increased cost..... 14
 - Papers solicited for July EMC Conference..... 14
 - Nominations of candidates for IEEE Fellow grade are being sought..... 16
 - INTERMAG abstract deadline set for December 7..... 19
 - Aerospace papers invited for NAECON '67..... 19
 - IEEE Executive Committee approves five Group Chapters..... 20
 - Conference in England to discuss solid-state devices..... 20
 - Schedule for G-AP symposium announced..... 22
 - Canadian engineers define program for June conference..... 22
 - Practical papers wanted for heating meeting..... 24
 - Region 6 meeting to feature tutorial sessions..... 24
 - London to host magnetic materials meeting..... 25
 - Departments coordinate to convert IEEE mailing list..... 25
- 27 Calendar
- 30 People
- 94 IEEE publications
- Scanning the issues, 94 Advance abstracts, 96 Translated journals, 108
 - Special publications, 113
- 114 Focal points
- Formation of USA Standards Institute is announced; successor to ASA..... 114
 - NASA, Sciences Academy invite engineers to join astronaut program for research in space..... 114
 - Lasers may enable spectators to view space walks from earth..... 114
 - Computer model of earth may reveal mineral deposits..... 116
 - 'Boresight' aligns antennas for satellite communications..... 116
 - Acoustic sensor monitors traffic flow..... 116
 - Washington University offers course in superconductivity..... 116
 - Applicants are sought for White House Fellowships..... 118
 - Papers are needed for Frequency Control Symposium..... 118
 - Drexel Institute announces graduate biomedical program..... 120
 - Gamma rays may control insect damage to stored food..... 120
- 122 Technical correspondence
- Campbell's electric wave filter, *J. E. Brittain, Lloyd Espenschied* Omission corrected, *David Y. Prihar* Radiant energy quanta, *A. G. Benedict* Other transportation meetings, *L. C. Edie*
 - Error in September issue, *Charles Sobel*
- 124 Book reviews
- New Library Books 134 Recent Books 135

the cover

Today, astronomers, astrophysicists and others are busy trying to explain spectacular solar phenomena such as the one shown on the cover, and the interaction of the solar wind with the earth's magnetosphere. A review of the latest findings begins on page 43.



Spectral lines

Importance of secondary publications. At present, the IEEE's major publications emphasis is on the printing of papers describing original scientific and technical work. This traditional activity of technical societies is called primary publication. The accumulated primary publications output of the IEEE is a certified archive of substantive scientific and technical papers. The certification procedure, subjecting each paper to careful scrutiny by anonymous reviewers who are expert in the field, has resulted in a technical literature of good quality and usefulness. This activity of the Institute is of primary importance, and ways to improve the coverage and quality of the papers need active investigation.

However, it is clear that even with improved primary publications, the Institute will not be satisfying the information needs of its members. So many pages of technical information are presently being published and the rate of increase is so high that the present method of disseminating technical information is becoming inadequate.

Many professional societies, including the IEEE, have found that the number of pages published has been increasing at a rate of close to 10 percent per year in this post-World War II era. This rate of increase means that, in less than eight years, the number of technical pages published will be doubled. It is unlikely that the reading speed or time available for technical reading of each member will also double in the same period. Another problem presented by the increase in pages is an economic one; the increased cost involved in publishing so many additional pages will require new sources of income or increased income from present sources.

Let's analyze the present situation more carefully. Although it is probably true that today's engineer is reading somewhat more than his predecessors, it is certainly not true that on the average he is reading an increasing *percentage* of the papers published. Thus, our present procedures are becoming increasingly inefficient in that more and more pages are being delivered to the individual and he generally reads a smaller portion of them. What is needed is an information system that is better shaped to the individual's need; in this way we may be able to prevent our publications program from running into economic trouble.

In an attempt to solve the problem, some professional societies have developed extensive secondary publications services. By secondary publications is meant the publication of lists of abstracts or indexes of articles

published in a large number of primary journals. Thus the reader may, by examining abstracts, select only those articles of interest to him and avoid receiving those that are not. In the past, such a system might have resulted in too much time delay, but the rapid data-handling capabilities of modern computers can eliminate much of this limitation.

Chemical Abstracts, a publication of abstracts of papers, including patents, of scientific and technical value to chemists is an example of a secondary publication. This service, which was started some 60 years ago by the American Chemical Society, now publishes almost 90 000 pages a year, almost twice the number of pages of primary literature published by the ACS. It has proved to be of tremendous importance to those in the field of chemistry.

In its review of future needs of the Institute (see President Shepherd's article in the October issue of IEEE SPECTRUM), the Board of Directors took two specific actions that may well have a far-reaching influence on the future publication activities of the Institute. First, it voted unanimously that the IEEE actively investigate the need for secondary information services in the field of electrical and electronics engineering; second, it voted the sum of \$45 000 to enable appropriate action to be taken.

To carry out this charge, the Institute will need to determine as precisely as possible what information services its members require. It cannot afford to develop services it thinks its members want but which do not prove to be economically viable. The Institute has within its membership the most active professionals in the electrical/electronics area. Some of these members are also expert in the information sciences. Such members and additional full-time staff will be needed to shape the development of an appropriate program.

A careful study will be made of services presently available through Engineering Index, the Institution of Electrical Engineers in the United Kingdom, the Engineering Societies Library, and various governmental information processing agencies.

While the Institute should work, and is working, cooperatively with other agencies in this field, it has the particular responsibility of insuring that the particular needs of its members are adequately provided for. With the action taken by the Board of Directors last August, it is now in a position to do so.

F. Karl Willenbrock

Authors

Plasmas in space (page 43)

Morton A. Levine, chief of the Plasma Astrophysics Branch of the Space Physics Laboratory, Air Force Cambridge Research Laboratories, Bedford, Mass., received the B.S. degree from the University of Massachusetts in 1947 and the M.S. degree from Tufts University in 1951. He has also studied at Massachusetts Institute of Technology, Boston University, Northeastern University, and the University of Minnesota. He was a staff member at Los Alamos Laboratory from 1943 to 1946. Between 1950 and 1954 he was a research associate at Tufts University. Immediately following, he joined Air Force Cambridge Research Laboratories. Since 1950 he has been concerned primarily with plasma physics and magnetic fields. He was one of the earliest to observe magnetohydrodynamic waves in a plasma and was cited by the Atomic Energy Commission for his contributions to the development of the stabilized pinch. Most recently, he has worked on MHD problems involved in astrophysics.



Solid-state HV dc transmission technology (page 48)

F. D. Kaiser (SM) received the B.E. degree from the University of Minnesota in 1940. His entire technical experience has been in specialized power transformer applications for electric arc furnaces and electronic power converter transformers as applied to electrometallurgical and electrochemical industries. He has been associated with the design of several highly special power supplies for such projects as Brookhaven's cosmotron and alternating gradient synchrotron, as well as high-voltage dc power supplies for BMEWS, Nike-Zeus, and other long-range radar projects. Currently, he is engineering manager of the Westinghouse DC Power Transmission Department, Sharon, Pa. He holds 19 patents in the fields of rectifier circuits and high-voltage windings. He is a member of the National Society of Professional Engineers and is a registered professional engineer in the state of Pennsylvania. In addition, Mr. Kaiser has devoted much effort to the formulation of standards for rectifier transformers.

Trends in digital communication by wire (page 52)

R. H. Franklin. A biographical sketch of Mr. Franklin appears on page 56 of the October 1966 issue.

H. B. Law received the B.Sc. Tech. degree in electrical engineering from Manchester University, England, in 1936. The following year he joined the Post Office Research Station, London, where he was concerned with quartz crystal oscillator development for radio and line carrier frequency control, wartime navigational aids, frequency standards, and standard frequency transmissions. From 1950 to 1955 he was involved in the study of long-distance, high-frequency radio telegraphy leading to new design and testing methods, including the use of an artificial fading machine. Because of this work, he was awarded IEE (London) premiums. During the late 1950s, he was responsible for the development of bandwidth-economy carrier terminal equipment for long submarine telephone cables. Recently, in addition to studying integrated pulse code modulation switching and transmission systems, he has been in charge of a division concerned with local telephony and switching. At present, Mr. Law is serving as deputy director of the Post Office Research Station.





L. E. Humphrey (M) graduated from the University of Nebraska and immediately joined Bakelite Corporation, where he participated in the research, development, and manufacture of polystyrene. During the war, he was the Army representative assigned to the Plastics Section, Chemicals Division, WPB. Subsequently, he served Union Carbide as general superintendent of its Bound Brook plant. As manager of Wire and Cable Resins he directed activities leading to the development of the insulated sodium conductor. He is now vice president of Nacon Corporation.



R. C. Hess (M) received the B.S. degree from Lebanon Valley College in 1941 and, in 1943, the M.S. degree from Lehigh University. He then joined Union Carbide, first as a development chemist and, later, worked in the fields of vinyl and polyethylene product development. In 1953 he was appointed Group Leader in charge of floor coverings and, from 1956 to 1962, he served as Group Leader in thermoplastic product development. He was appointed Project Scientist in 1962 and has been working on the insulated sodium conductor project since its inception.



G. I. Addis received the M.E. degree in 1938 from Stevens Institute of Technology and the Ph.D. degree from Johns Hopkins in 1942. He then worked in the fields of chemical process development and the application of computers to chemical processing problems and, in 1954, he joined Union Carbide as Group Leader of the special instrument section. Later, he was appointed Assistant Director for vinyl resin development. He has been working on the sodium conductor project since its inception. He is a member of both Sigma Xi and Tau Beta Pi.



A. E. Ruprecht (M) received the B.S. degree from Carnegie Institute of Technology in 1955 and then worked for National Electric Products Company as a cable engineer. In 1956 he joined H. K. Porter Company as wire and cable manufacturing manager and, subsequently, was appointed chief cable engineer. He became a product development engineer at the Simplex Wire and Cable Company in 1953 and assumed responsibility for sodium conductor cable development. Presently, he is manager of application engineering in the Power and Control Division.



P. H. Ware (SM) received the B.S. and M.S. degrees from M.I.T. He first joined Simplex Wire and Cable Company as a laboratory engineer, and was appointed head of their electrical laboratory in 1953. Later, he joined the Research Department, where he specialized in studies concerned with future possibilities in the field of power transmission and distribution. In 1966 he became manager of Power Systems Engineering on the Corporate Engineering staff. He is responsible for long-range voltage developments in high-voltage cable for power transmission.



E. J. Steeve (M) received the B.S. degree in electrical engineering from Northwestern University and later did graduate work at Northwestern and at the University of Chicago. Upon joining the Commonwealth Edison Company in 1948, he was assigned to the Construction Department and, subsequently, he assumed managerial responsibility for it. He then worked in the areas of distribution engineering and system planning and, presently, he is general design engineer in charge of underground line. He has also guided many company research projects.



J. A. Schneider (SM) graduated from the Illinois Institute of Technology and then joined the Commonwealth Edison Company. First with the Line Design Department, he became area engineer for the Western Division in 1961. He later served as division engineer for the Chicago Central Division and as assistant to the superintendent of transmission and distribution construction. At present, he is staff assistant to the operating manager. This assignment involves work on budgets, training, safety, work practices, and transportation equipment.



I. F. Matthyse (SM) received the B.S. degree from both Cooper Union and New York University, and the M.S. degree from the latter. He joined Burndy Corporation in 1928 and has since worked on the design, development, and research associated with electrical connectors and special fuses. He has been granted 41 U.S. patents and has numerous patents pending. He is a member of the Electrochemical Society and CIGRE, and is a Professional Engineer in Connecticut. The author of over 25 papers, he has been active on committees of IEEE, EEI, and NEMA.



E. M. Scoran received degrees from the University of Connecticut and Fordham University and then joined General Precision, Inc., as a staff research chemist on ferromagnetic and thermoelectric materials and single crystal growing techniques. In 1961 he joined Engelhard Industries, Inc., where he did research on the analysis of precious metals. Since 1963 he has been working in the advanced development section of the Engineering Department of Burndy Corporation, Norwalk, Conn. He belongs to the American Chemical Society.



Communications—concept and reality (page 82)

W. Deming Lewis, president of Lehigh University, received the B.A., M.A., and Ph.D. degrees from Harvard University. As a Rhodes Scholar at Oxford University, he received two degrees in advanced mathematics. Associated with the Bell System since 1941, he was one of those who initiated the work of Bellcomm, Inc., where he was managing director of the Systems Studies Center for two years. He was also executive director of Research Communications Systems at the Bell Telephone Laboratories. He holds 33 U.S. patents, and has served as a charter member of the Polaris Command Communications Committee and of the Defense Industry Advisory Committee. He is vice president of the Naval Research Advisory Committee and past chairman of the Council for the Harvard Foundation for Advanced Study and Research. He has served on the Board of Governors and as a vice president of the Harvard Engineering Society.

A nonmagnetic laboratory for the National Bureau of Standards (page 85)

Forest K. Harris (F) received the B.A. and M.S. degrees from the University of Oklahoma and a Ph.D. degree from Johns Hopkins University. He joined the National Bureau of Standards as a physicist in 1923. Since joining the Electricity Division in 1925, he has served in the instruments section, the applied electricity section, the high voltage section, and is currently chief of the absolute electrical measurements section. He was professional lecturer in electrical engineering at George Washington University from 1941 to 1960 and has been adjunct professor of engineering there since 1960. His book *Electrical Measurements* was published in 1952 and has since been used as a text by a number of universities both in the United States and abroad. He was awarded a Department of Commerce medal for distinguished authorship and is a Fellow of the Washington Academy of Sciences and a member of the USA Standards Institute.



Although 95 percent of the universe is made up of ionized gases or plasma, and although most plasmas exist in magnetic fields, the problem of the behavior of these gases in magnetic fields is a relatively new field of scientific investigation. This article reviews the new findings and speculations on solar dynamics, and concentrates especially on the interactions of the solar wind with the magnetosphere of our earth. Out of the combined efforts of astronomers, physicists, engineers, and geophysicists, a picture of plasmic-magnetic interaction is beginning to emerge.

Today, astronomers are busy trying to explain the mechanisms underlying such spectacular solar events as solar turbulence, solar magnetic fields, solar flares, the sunspots, solar prominences (see title illustration), and the solar corona. Astronauts are equally busy trying to measure the results of these phenomena in our near space environment, while physicists are trying to model the dynamics of such events in laboratory experiments here on earth. The common denominator of all these efforts is that they deal with the properties of plasmas or ionized gases.

As man's interest has grown in pushing travel out into space, the specific problems of plasma, its density and other characteristics, have become more important. Of prime importance is the plasma near the earth, which is of solar origin, and which is brought to us on the "solar wind." However, the mechanisms by which the sun emits plasma are not understood nor are its interactions with the magnetosphere of our earth.

Ninety-five percent of the universe is made up of ionized gases or plasmas. All stars, including our sun, consist of ionized gas. Most plasmas exist in magnetic fields, yet the problem of the behavior of ionized gases in magnetic fields constitutes a relatively new area of scientific investigation. This new field got its major impetus through a book by Dr. Hans Alfvén, *Cosmical Electrodynamics*, published in 1950.¹

The plasma problem that is of central interest today revolves around the solar wind, its origin, its characteristics, and, especially, its effect on the earth's magnetosphere. To examine these questions in detail, NEREM in 1964,² and again in 1965,³ devoted special sessions to plasma astrophysics. This article reviews some of the ideas developed during those sessions, and draws on the work of such men as D. H. Menzel of Harvard University, W. H. Bostick of Stevens Institute of Technology, A. J. Lazarus of M.I.T., J. M. Beckers of the AFCRL Sacramento Peak Observatory, R. S. Kushwaha of AFCRL, H. E. Petschek of AVCO, and others whose work has been important in the field.

Solar dynamics

The solar wind is thought to be the product of the many different activities in the solar atmosphere; how-

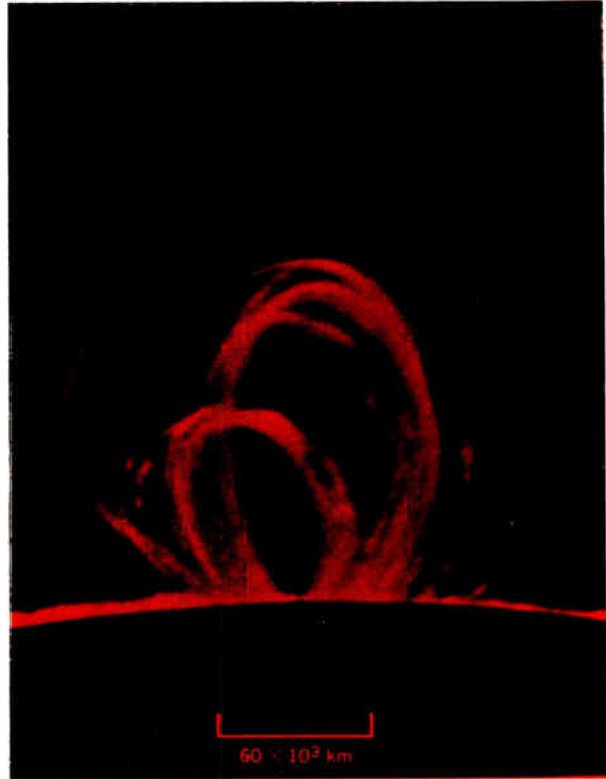

Loop prominence over an active center.*

Plasmas in space

The mechanics by which the sun emits plasma are not well understood, nor are the interactions of the solar wind with the magnetosphere of our earth; but the true picture is now slowly beginning to unfold

Morton A. Levine

Air Force Cambridge Research Laboratories

ever, it is difficult to predict or calculate the specifics of the solar wind because our knowledge of the sun is both figuratively and literally very superficial. What is known about the sun must be inferred from what can be seen on the sun's surface. The limit of our visibility is the photosphere, a layer about 200 or 300 km thick with a density only 10^{-5} to 10^{-8} that of the earth's atmosphere, containing a small amount of negative hydrogen that renders it opaque. However, the photosphere is white hot with a temperature of 6000°K and is responsible for

*All photos by Sacramento Peak Observatory.

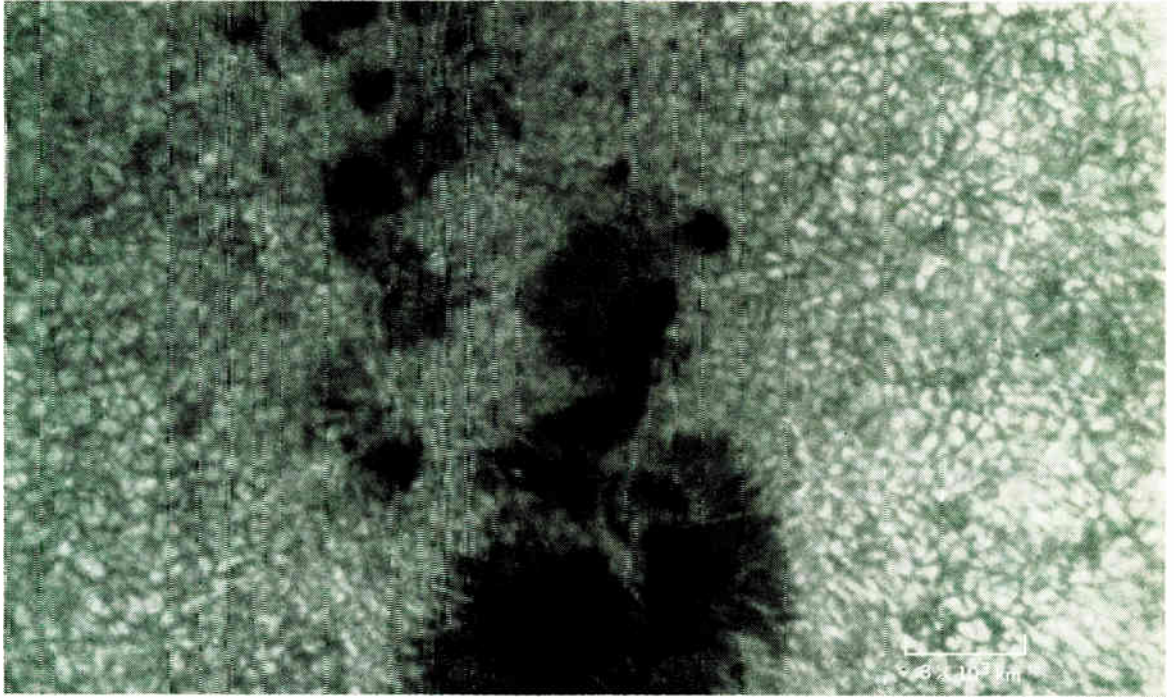

Fig. 1. This photo of a sunspot group or active region in the sun's photosphere shows clearly the photospheric granulation that occurs because of thermal instabilities.

most of the light and energy emitted from the sun. At the same time, the opacity of the photosphere prevents any outward radiative transfer of energy from the solar core; energy can penetrate the photosphere only through heat conduction or through convection currents. Heat conduction does not prove a very effective energy transfer mechanism, and a sharp thermal gradient is set up from the solar surface inward. This thermal gradient sets the stage for large-scale instabilities and convective cells called granules.

Although the brightness fluctuations in granules are quite small, suggesting temperature differences of only 100°K or less, they are clearly visible (see Fig. 1). Figure 1 is a recent photograph taken through very narrow band spectroscopic filters at the Sacramento Peak Observatory. In fact, by using very narrow band filters and thus taking advantage of the Doppler shift in line intensity as the granules moved up and down, Sacramento Peak has made spectacular moving pictures showing a grain life of about 8½ minutes.

In addition to the granulation, there are large dark spots or sunspots in the photosphere. These spots, so large that at times they can be seen by the naked eye, were even observed in ancient times by the Chinese. The area of the sunspot appears dark because its temperature is as much as a thousand degrees lower than the temperature of the surrounding photosphere. In addition, through spectroscopy, astronomers have shown that the magnetic fields in sunspots are as high as 4000 gauss (0.4 tesla). Dr. Menzel has put forth the theory that the high-temperature gradients in the region of a sunspot lead to convective instabilities, and to turbulence that gives rise to other events in the neighborhood of sunspots.² These events can take the form of plages, flares, prominences, and coronal activity in the chromosphere

and corona that lie above the photosphere. As can be seen in Fig. 1, sunspots tend to occur in groups or centers of activity. These centers of activity follow a definite solar cycle that varies in duration but that seems to have a mean period of 11 years. Above the photosphere sits the chromosphere, a layer about 12000 km thick, which reflects many photosphere activities. Normally the chromosphere is invisible. It can only be seen during an eclipse of the sun by the moon, or through a special occulting telescope such as the coronagraph. The chromosphere temperature is about 10000°K; however, its density is so slight that only certain spectral lines are emitted. This is in contrast to the continuum emitted in the photosphere. Figure 2 shows a picture of the sun taken with a narrow band filter that emphasizes the chromospheric light. Whereas the chromosphere is normally invisible, flares and loop prominences, such as shown in the title illustration and in Fig. 3, are very visible; these occur, in part, in the chromosphere.

Above the chromosphere is the corona,⁴ extending out several solar radii. The corona does not have a symmetric shape, but rather exhibits patterns radiating from the sun. These shapes are cyclic and may be the response to cyclic solar magnetic field and sunspot activity. The density of the corona is very low (10^{-10} to 10^{-14} times that of the earth's atmosphere). The surprising thing is that the corona has a temperature of over 10^6 °K; that is, it is far hotter than either the photosphere or chromosphere.

How is the corona heated? Current theories relate the heating to the granulation³ on the surface of the photosphere. It is argued that in the rapid motion of granules from beneath the photosphere, shock waves are developed. These shock waves are then transmitted through the chromosphere and dump energy into the corona. Al-

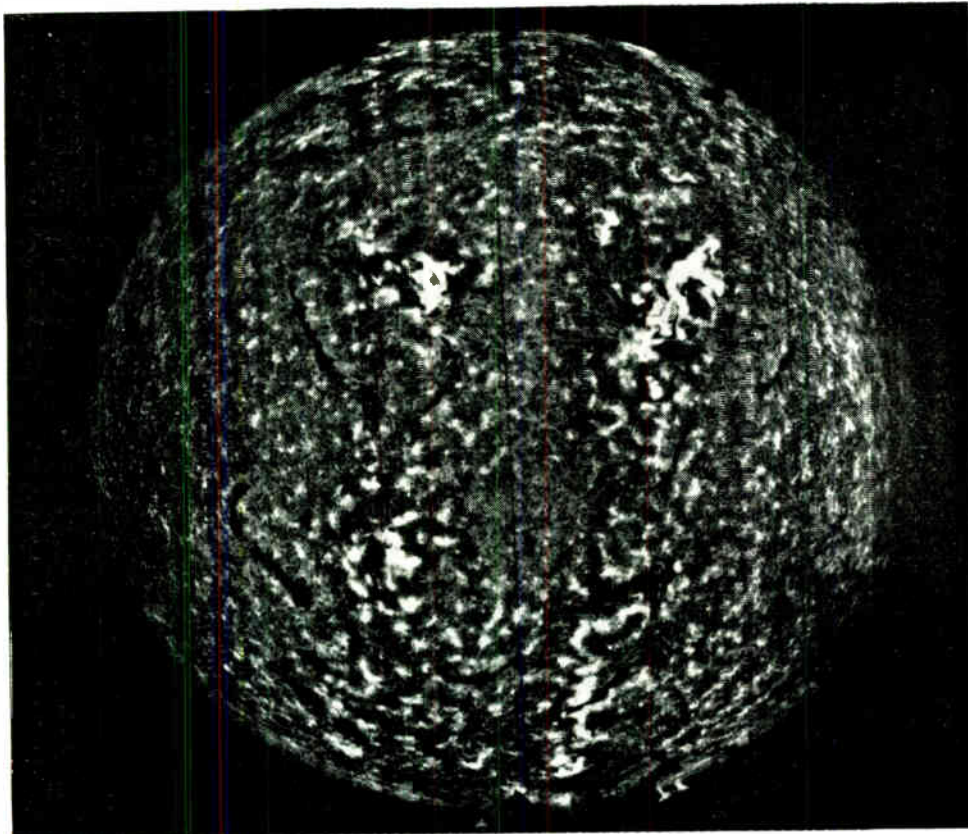

Fig. 2. Chromosphere in H_{α} light seen in projection against the solar disk.

though attempts to create a quantitative picture of this process have thus far failed,⁶ the outlines of this theory are widely held to be valid. In fact, estimates of the magnitude of this effect show temperatures in the corona far higher than the million degrees presently observed. At this juncture, the question may be not why the corona is so hot, but why the corona is so cool. The Russian astronomer Pikel'ner has postulated that the corona is cooled by the evaporation of material.⁷ In his theory, relatively cool material from the chromosphere passes up into the corona where it is heated and evaporated, taking away energy. This evaporating material then constitutes a solar wind. Thus the amount of solar wind escaping may be a direct function of the coronal heating, and in this sense independent of the mechanism.

The solar wind

Since the early 1900s it has been suspected that something like a solar wind exists⁸ and there have been many attempts to calculate its magnitude and nature. It is now thought that the solar wind is made up of two components, a quiet sun component resulting from the boiling of the corona as described, and an active sun component occurring concurrently with sunspot activity. One approach to calculating the quiet sun component utilizes a kinetic theory calculation first introduced by Jeans⁹ in 1926 and modified many times since. A second approach relies on a fluid dynamic theory proposed in 1959 by Parker¹⁰ and recently modified by Sturrock and Hartle.¹¹ With either approach, one is able to calculate numbers corresponding to early satellite measurements.

As yet, there are few theories and little information on the second solar wind component corresponding to intensified solar activity and sunspots. It is known that in conjunction with solar activity cosmic rays with energies as high as 100 MeV (1.6×10^{-11} J) have been measured, and concurrent with solar flares magnetic storms and the aurora borealis are observed. Satellite probes are just now beginning to bring back the type of data needed to understand this second component of the solar wind.

One measurement of the solar wind in the earth's orbit during a quiet sun shows that it consists of about $2-7 \times 10^6$ protons/m³ with a velocity radial to the sun of about 335 km/s and a temperature of over 10000°K.¹² We might ask why such a low intensity of particles is significant. The answer is that the conductivity of this plasma or solar wind is very high and it interacts with the earth's magnetic field over a tremendous distance, out to approximately 15 earth radii. Thus the solar wind pushes the earth's magnetosphere and is responsible for a variety of geophysical effects, such as ionospheric heating.

As the solar wind impinges on the earth's magnetosphere at supersonic velocities a shock wave results, the nature of which it is difficult to understand. The density of the particles in the impinging plasma is so low that interparticle collisions are negligible, whereas in an ordinary shock interparticle collisions are the key interactions, serving to randomize the directed momentum of the particles and giving rise to high temperatures behind the shock front. If there are no interparticle collisions a new mechanism must be found to randomize the incoming momentum. Recently, Petschek,¹³ Piddington,¹¹

and others have developed a turbulence picture for the shock front. Recent satellite measurements by Ness¹⁵ and others seem to confirm the Petschek interaction. In this theory there are unstable waves; that is, waves that can be fed energy from the shock front and that propagate out in front of it. This could not happen in an ordinary shock wave because all wave velocities are slower than the shock velocity. However, in a magneto-hydrodynamic plasma there are a large variety of wave modes and it is possible to find waves that have velocities larger than the shock velocity. In particular, these waves propagate more nearly along magnetic field lines, whereas the shock front propagates perpendicular to the field line. If, then, waves gain energy in the shock front they create large-scale random electric fields behind the shock. It is these large electric fields and time-varying magnetic fields that serve to randomize particle velocities. Thus, the solar wind impinging on the earth's magnetosphere is suddenly stopped when it encounters the earth's magnetic field. A sharp front develops in which waves can be generated and amplified. These waves propagate out in front of the shock front, creating turbulent electric and magnetic fields. As the particles go through the shock front into these turbulent fields, their energies are randomized and the directed momentum of the plasma is thermalized, creating a relatively slow flowing hot plasma.

Interaction of solar wind and magnetosphere

Years ago, Chapman and Ferraro¹⁶ pointed out many of the features of the earth's day side interaction with the solar wind. Recently, Beard¹⁷ successfully treated the position and shape on the day side of the earth called the bow shock and magnetosphere. In this calculation it was possible to neglect the nature of the interaction. On the basis of simple conservation of momentum and pressure balance, Beard derived a shape since confirmed by satellite measurements. An interesting feature of the day side interaction are the so-called neutral points—the points where a magnetic field line supposedly goes straight down into the earth's atmosphere. At first it was thought that the plasma would follow these lines and flow directly into the earth's atmosphere. It now seems that this may not be possible, and that a mechanism that excludes plasma from flowing into high magnetic field regions may keep the particles from flowing into the earth's field. This is related to mirror or cusp containment, so often referred to in thermonuclear research.

Predicting the behavior of the solar wind-earth interaction on the night side has turned out to be a much more difficult problem, and at the present time there is no theory that gives good agreement with satellite data. As Piddington pointed out, there are two possibilities for predicting the form of the interaction. If, on the one hand, the solar wind flow around the earth is laminar, then an open tail can be expected. On the other hand, if the solar wind flow around the earth is turbulent with a frictional-type interaction, the magnetic field of the earth will be pulled and stretched out by solar wind, making the nature of the tail difficult to predict. A major opinion held by Dessler,¹⁸ Axford,¹⁹ Piddington,¹⁴ and Ness²⁰ is that the tail of the magnetosphere is essentially open with a neutral sheet. A second theory, illustrated here, predicts that the solar wind feeds energy into the earth's magnetic field stretching the lines out behind the earth into the tail region. This interaction then leads to a flow

of material back to the earth from the solar wind through the tail. It remains to be seen which of the pictures will prove to be most nearly correct or what combination of these pictures corresponds to the true magnetospheric tail (see Fig. 4). Actually, the tail is an extremely important region of the interaction, for it may turn out to control much of the flow of solar wind that takes place into the earth's atmosphere.

So far unmentioned are the Van Allen belts and aurora borealis. As yet theories of their origin are still very speculative.

Fig. 3. Sequence showing development of a spray prominence associated with a flare, February 10, 1956.

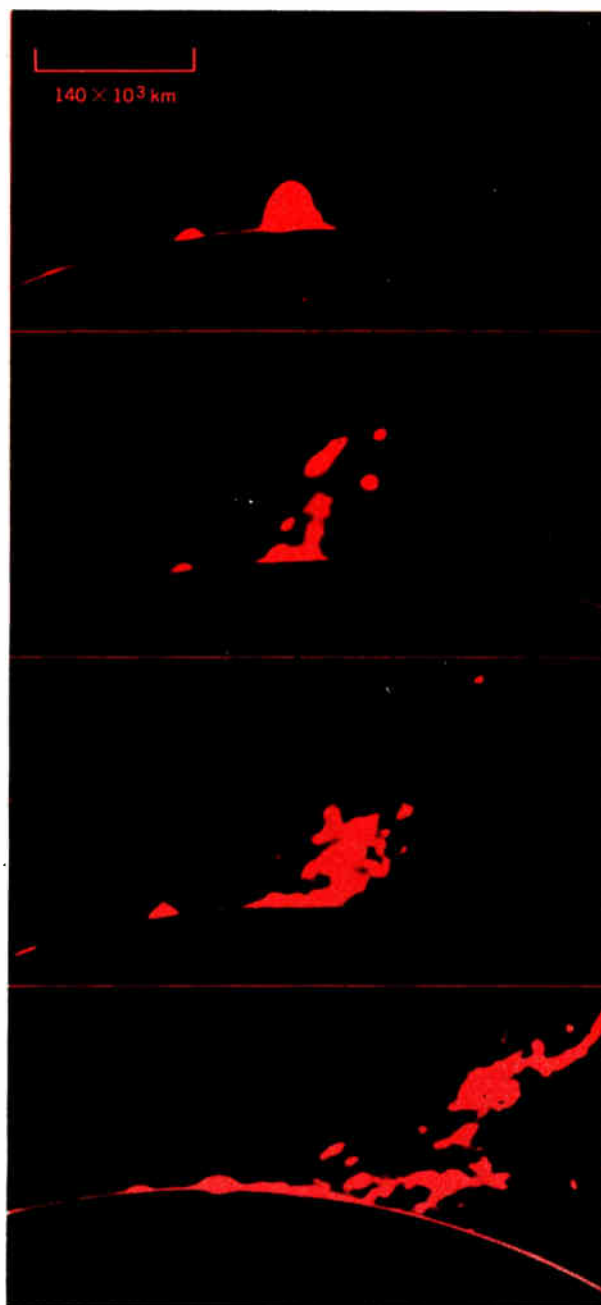

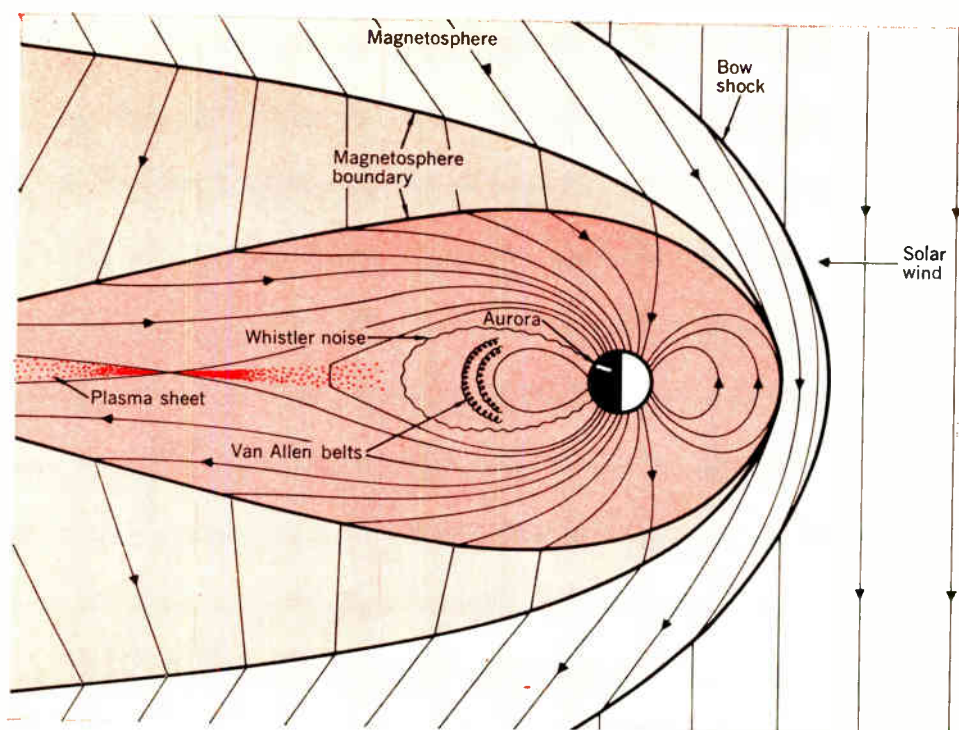

Fig. 4. Recent model of the earth's magnetosphere proposed by H. Petschek.

A direct method of studying the earth's magnetosphere in its interaction with the solar wind would be to do a laboratory experiment that modeled this interaction; and, in fact, many laboratories are attempting just this. Unfortunately, the problem of modeling the solar wind is not a simple one. The key to the effect is the collisionless shock. Laboratory experiments must employ a plasma sparse enough so that collisions are not important and yet with sufficient momentum to affect the boundaries in the field. At the same time, the magnetic field must be strong enough so that the particles are turned within the boundaries of a reasonable apparatus size. These parameters combine to make the experiment most difficult. Thus far each laboratory has chosen to compromise with one or more of the scaling parameters. Although several interesting phenomena have been illustrated, it is really too early to specify the significance of any of the laboratory experiments.

Conclusion

It is interesting to note how the many people of different disciplines are cooperating to investigate the solar wind interaction problem. The predictions of theoretical astronomers, coupled with the fine spectroscopic and observational data of laboratories such as the Sac Peak Observatory, have given much information on the sun. Theoretical physicists have helped to interpret these data to give temperatures. Engineers and space scientists have brought back measurements from satellites, and experimental physicists have attempted to duplicate these experiments in the laboratory. Geophysicists have contributed data from interactions in the upper atmosphere.

All this adds up to a massive effort to understand the plasma environment, at least in the space near the earth. Now is a most exciting time, as the true picture slowly unfolds.

REFERENCES

1. Alfvén, H., *Cosmical Electrodynamics*. New York: Oxford, 1950.
2. *NEREM Record*, vol. 6, pp. 146-150, Nov. 1964.
3. *NEREM Record*, vol. 7, pp. 96-101, Nov. 1965.
4. Evans, J. W., ed., *The Solar Corona*. New York: Academic Press, 1963.
5. Osterbrook, D. E., "The heating of the solar chromosphere, plages, and corona by magnetohydrodynamic waves," *Astrophysical J.*, vol. 134, p. 347, 1961.
6. Parker, E. N., "Comments on coronal heating," in *The Solar Corona*, J. W. Evans, ed. New York: Academic Press, 1963, p. 11.
7. Pikel'ner, S. B., "The dissipation of the corona and its significance," *Dokl. Akad. Nauk., SSSR*, vol. 72, p. 255, 1950.
8. Birkeland, Kr., "Sur les rayons cathodiques sous l'action de forces magnétiques intenses," *Arch. Sci. Phys. et Nat.*, Geneva, 4th period, vol. 1, pp. 497-512, June 1896.
9. Jeans, J. H., *The Dynamical Theory of Gases*. New York: Dover, pp. 249-255, 1961.
10. Parker, E. N., "Dynamical theory of the solar wind," *Space Sci. Rev.*, vol. 4, p. 668, 1965.
11. Sturrock, P. A., and Hartle, R. E., "Two fluid models of the solar wind," *Phys. Rev. Ltrs.*, vol. 16, p. 628, 1966.
12. Strong, I. B., Asbridge, J. R., Bame, S. J., Hedman, H. H., and Hundhausen, A. J., "Measurement of proton temperature in the solar wind," *Phys. Rev. Ltrs.*, vol. 16, p. 631, 1966.
13. Petschek, H. E., "Magnetic field annihilation," in *AAS, NASA, Symposium on the Physics of Solar Flares*, W. N. Ness, ed., NASA SP-50, 1964.
14. Piddington, J. H., "Geomagnetic storms, auroras and associated effects," *Space Sci. Rev.*, vol. 3, p. 724, 1964.
15. Ness, N. F., Searce, C. S., and Geck, J. B., "Initial results of the Imp I magnetic field experiment," *J. Geophys.*, vol. 69, p. 3531, 1964.
16. Chapman, S. D., and Ferraro, U. E. A., "A new theory of magnetic storms," *Terrest. Magnetism Atmospheric Elec.*, vol. 36, pp. 77-97 and 171-186, 1931; vol. 37, pp. 147-156 and 421-429, 1932; vol. 38, pp. 79-96, 1933.
17. Beard, D. B., "The solar wind geomagnetic field boundary," *Rev. Geophys.*, vol. 2, p. 335, 1964.
18. Dessler, A. J., and Michel, F. C., "Plasma in geomagnetic tail," *J. Geophys.*, vol. 71, p. 1421, 1965.
19. Axford, W. I., Petschek, H. E., and Sisco, G. L., "The tail of the magnetosphere," *J. Geophys. Res.*, vol. 70, p. 1321, 1965.
20. Ness, N. F., "The earth's magnetic tail," *J. Geophys. Res.*, vol. 70, p. 2989, 1965.

Solid-state HV dc

The thyristor; a solid-state power switching device; offers numerous advantages over conventional mercury valves and is expected to provide a great impetus to the development of high-voltage dc transmission throughout the world

F. D. Kaiser Westinghouse Electric Corporation

Studies have been made during the past few years to determine the feasibility of employing thyristors in high-voltage dc converter terminals. Overall objectives have also included the integration of solid-state circuitry in order to take advantage of the fast response times associated with thyristors. Because of their advantages over mercury valves, from the point of view of economy as well as performance, a bright future is seen for these solid-state devices in the dc power field.

High-power mercury converter valves and the associated dc transmission technology have demonstrated their capabilities in many areas of the world. With each new project the technology is advanced to some degree simply because more people are exposed to it. Prior to 1965, all planned and approved dc transmission projects were outside the North American continent. During 1965, contracts for three projects in North America—the Vancouver Island to Mainland, and the two United States interties from The Dalles, Oreg., to Hoover Dam and to Los Angeles—were consummated.

According to a recent announcement,¹ an underground dc link will be built to two points in London to transmit 640 MW from the Kingsnorth Generating Station. This announcement raises a question as to the future, if any, for a 700-kV ac grid for Great Britain. Such a development is significant to power engineers the world over, and warrants consideration and study in other geographical areas.

Some of the criteria that influenced the foregoing decision are certainly apparent when the following advantages of high-voltage dc power transmission are examined:

1. Reduced cost of overhead transmission line.
2. Reduced underground or underwater cable cost.
3. Nonsynchronous tie between systems.
4. No increase in fault capacity.
5. Applicability to a coordinated power concept.

By the end of 1966 it appears likely that several additional procurements for projects, such as Churchill Falls in Labrador and Nelson River in Manitoba, may be obtained on the basis of dc transmission. In the United States other HV dc projects, some of which involve solid-state thyristor terminals, are under study.

A review of the solid-state technology

In 1964, a group of engineers at Westinghouse was charged with the task of determining the feasibility of applying solid-state thyristors to a high-voltage dc

converter terminal. At that time, applications of thyristors to many thousands of kilowatts in reversing mill drives for metal processing were under construction.² The solution to the problem of paralleling thyristors for high currents required for 750-volt dc reversing motors was no small accomplishment. For the metals industry the quest for a totally new controlled dc power source was a significant advance.

The main tasks facing the group studying thyristor applications were to solve the problems involved in gating series strings of thyristors and the problems of equal voltage distribution during turn-on and turnoff as well as during irregular dropouts due to oscillations. Significant accomplishments of this group included the development of several proved means to gate and control a series string of thyristors throughout a full range of control angles for both converter and inverter operation.³

Optimization of thyristors

Once the feasibility of connecting thyristors in series had been conclusively demonstrated, attention was focused upon exploiting the full potential capabilities of a high-power thyristor specifically for HV dc applications. In order to maximize these developments a parallel attack on the problems was launched. The device technology was re-evaluated for the purpose of optimizing for HV dc applications such device characteristics as di/dt , dv/dt , peak inverse voltage rating, forward voltage drop, and I^2t capability. Improvement in di/dt characteristics results in a reduction in reactive requirements; better dv/dt means less margin angle and less reactive compensation; higher peak inverse voltage rating and lower forward voltage drop result in improved efficiency; and I^2t capability determines transient overload.

Particular attention was focused upon physical device geometry and mechanical construction so that optimum configuration for use in oil could be achieved, thus af-

transmission technology

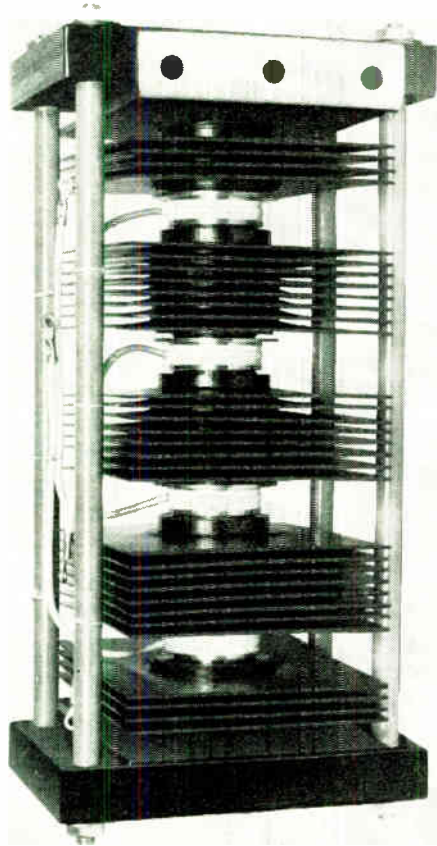

Fig. 1. Typical thyristor module, with peak inverse voltage rating of 10 kV.

fording maximum utilization of the thermal, dielectric, and mechanical characteristics of the devices. A typical thyristor module is shown in Fig. 1.

Solid-state logic

In parallel with device technology developments were advances in solid-state control and logic to take full advantage of the faster response times associated with thyristors as compared with mercury. Solid-state high-speed logic circuitry, which forms the heart of all modern computers, has already achieved a high degree of reliability. Its application to high-speed power thyristors complements the overall solid-state HV dc technology.

A control system having continuous and instantaneous monitoring with memory capability, and able to make decisions within microseconds, has been developed to

provide for turn-on control only when admissible for the thyristors. It can take corrective measures without bypass valve action, as required in mercury valves, and it provides redundant functions to take care of momentary disturbances.

Let us assume that an inverter is subjected to a momentary single commutation failure. The process of correction calls for a means of preventing a double commutation failure. Logic control can sense this inverter disturbance and make a decision to advance the gating of the incoming thyristor 60 degrees, so as to insure commutation with the increased fault current. In case of missing pulses, instantaneous corrective pulses by an auxiliary pulse generator take over automatically. In addition, the control checks out the circuit and returns it to normal operation after the disturbance has passed; see Fig. 2.

Thyristor HV dc laboratory

Concurrent with advances in thyristor optimization and development of high-speed logic for control and protection of thyristors is the necessity for a suitable laboratory facility. In view of the objectives of the thyristor development program and the overall objectives in solid-state HV dc technology, the laboratory should, as a minimum, provide facilities to test series thyristors elevated 200 kV dc above ground, and be capable of thermal loading to a module rating of 600 amperes dc back to back or 1200 amperes dc on resistive load. The facilities should be flexible in arrangement as to system reactance so that di/dt requirements can be varied over a wide range.

Figure 3 shows the main power circuit of the thyristor converter laboratory. The initial converters are of air-insulated indoor construction to expedite optimization of the thyristor characteristics. The second and later generations of thyristor evaluations will be in outdoor oil-insulated assemblies.

In order to minimize the number of devices connected in series so that replacement with improved units is practical as new characteristics are developed, the scheme of biasing an equivalent portion of a bridge 200 kV dc above ground is utilized. This method provides a sufficient number of thyristors in series that the gating and voltage-division characteristics can be tested during operation at a potential that is equivalent to a complete 200-kV dc bridge.

The equivalent bridge section is designed for 5 kV. The converter transformers and reactors, which were also designed for this voltage, are mounted on a structure insulated from ground. The large oil-filled insulators on

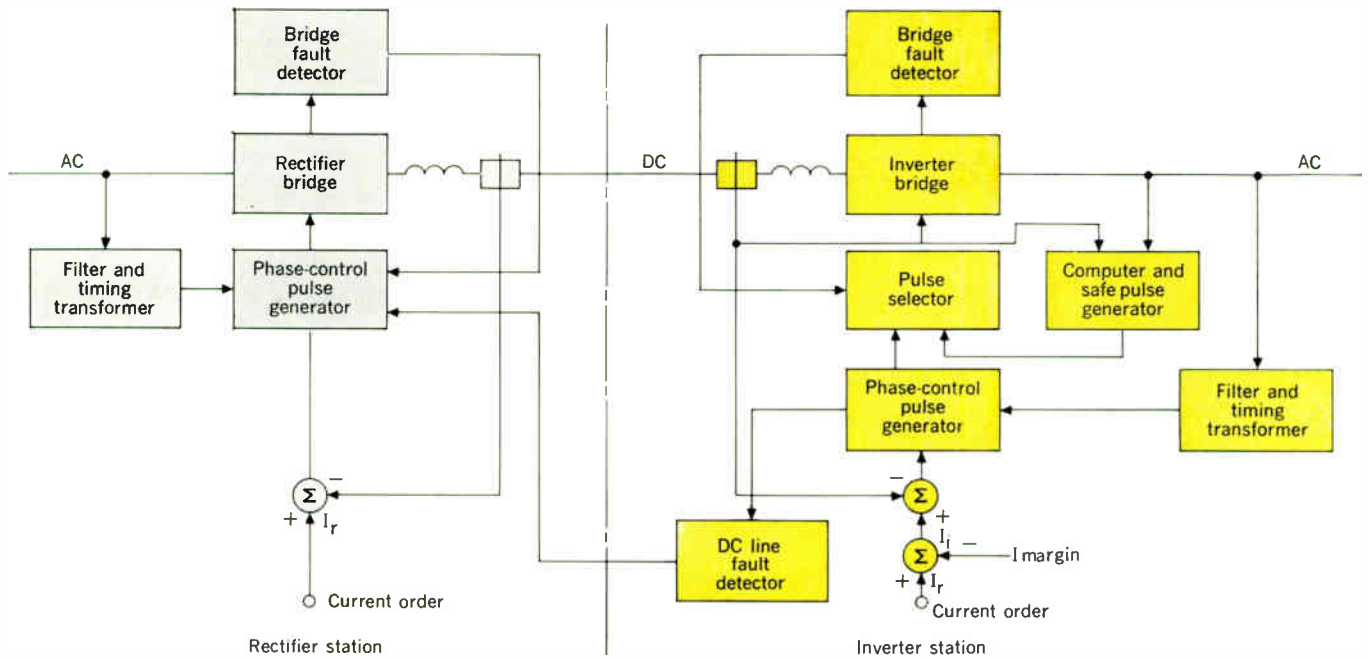
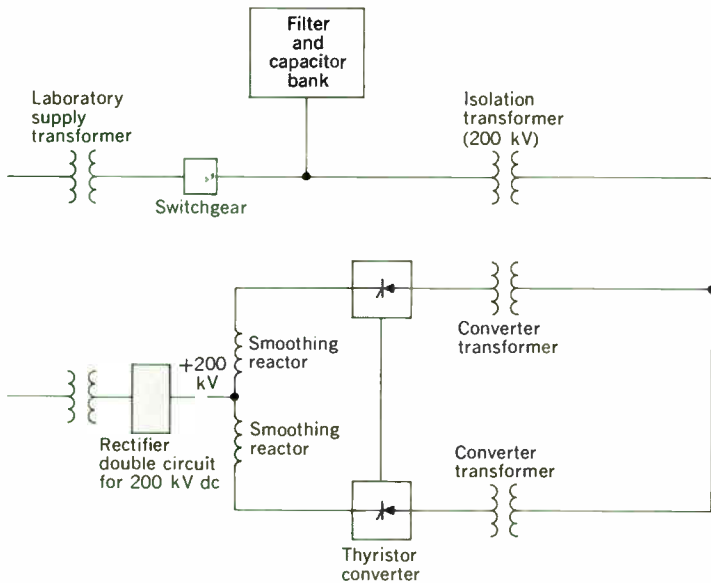

Fig. 2. Control and protection of thyristor HV dc line transmission.

Fig. 3. Schematic diagram of main power circuit of thyristor converter laboratory.



which the outdoor structure is mounted can be seen in the lower portion of Fig. 4.

With the outdoor portion of the laboratory elevated 200 kV dc above ground, it is necessary to isolate the 5-kV ac supply. This isolation is provided by the one-to-one transformer shown in the left-hand portion of Fig. 4. The three secondary leads are brought out through a single 200-kV bushing.

In order to get the converter transformer leads into the building and the dc leads out to the reactors and resistors, a special wall bushing was designed; see Fig. 4, upper middle portion. All of the leads going in and out of the building are 5-kV insulated cable spaced within a 10-inch aluminum pipe in the center of the wall bushing. One-inch-thick lucite is used to position the pipe and insulate it from the ground plane. A computer flux plot program was used to ensure proper design of the bushing.

Oil-immersed thyristors

In mercury converter terminals the valves are located indoors in a valve hall, which also usually includes degassing facilities and a clean room for valve maintenance. The valve hall requires proper ventilation or air conditioning and should be shielded with a Faraday cage. The introduction of the concept of modular 12-phase oil-immersed HV dc thyristor terminals promises to change economic parameters for dc applications.⁴

The 12-phase thyristor arrangement is achieved without economic penalty by the double-secondary converter transformer and by "packaging" the thyristors in groups of 12 to form two six-phase, two-way circuits. The six-phase groups can be connected in series or in parallel depending upon direct current and voltage requirements per module. This technique reduces the size of the ac filter and permits applications to high-reactance systems without derating of the converter equipment. A design has been proposed for a 300-MW, 1200-ampere bipolar thyristor converter outdoor terminal, compacted to 200 MW per acre as compared with 30 to 40 MW per acre for existing mercury installations.

New power concepts

The deionization time of mercury is approximately 200 microseconds; with margins required at rated currents or currents resulting from single commutation failures, a safe margin angle of not less than 20 degrees has been used for mercury terminals.

Solid-state thyristors have a recovery voltage characteristic at least one tenth of that of mercury and have di/dt and dv/dt characteristics such that safe operation is possible with a 5- to 10-degree margin angle. Thus less per-unit reactive compensation is required.

Consider a unit generator scheme in which a generator

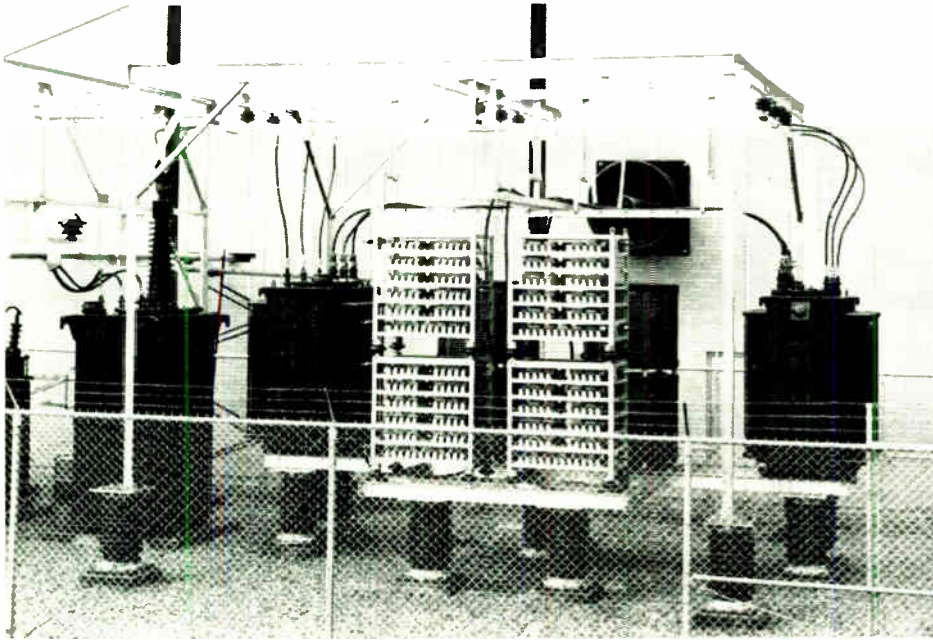

Fig. 4. Outdoor portion of HV dc laboratory.

is connected directly to a converter transformer and a 12-phase converter matched in rating to the generator. This setup would eliminate the constant-voltage bus and step-up transformer. If we allow the generator frequency to increase to 100 to 200 Hz, the generator and transformer cost and weight per megawatt can be reduced, as can the cost for frequency control. This kind of scheme is feasible and merits consideration for a hydro or thermal development with machines rated 200 to 400 MW and a subtransient reactance of 25 to 35 percent, or even higher. Tests on a 120-MW turbogenerator feeding a dc link were performed in England in 1965 with a mercury converter at essentially rated frequency to establish the basic feasibility of a unit generator and dc link scheme.⁵

Another application using the thyristor modular concept is a 120-MW back-to-back terminal, which provides a nonsynchronous tie between two large systems. Functionally the dc link acts as a static and instantaneous phase-angle regulator. It is capable of precise power dispatching in either direction, both on a steady-state basis and on a cyclical basis to provide both positive and nega-

tive damping between the systems during cyclical frequency drift. Such a terminal might find application on a tie between two large systems, one predominantly hydro and the other predominantly thermal, having different natural frequency-response characteristics.

Conclusions

Solid-state technological developments have made possible the application of thyristor HV dc terminals, which have the following important advantages over mercury terminals:

1. No arc-backs.
2. No valve hall requirement.
3. No need for degassing facilities or clean rooms.
4. No need for bypass valves.
5. Relatively short deionization time.
6. Lower maintenance.
7. No deterioration in service.
8. No warm-up time.
9. Reduction of substation space by 80 percent.

There are cost advantages as well. Table I shows a cost evaluation, on a projected basis, of a "turnkey" installation of a 1000-MW terminal.

In view of the advances being made in solid-state technology, it is expected that dc applications will be used to solve many future power-industry problems.

Essentially full text of a paper presented at the American Power Conference, Chicago, Ill., Apr. 26-28, 1966.

REFERENCES

1. News item, *Elec. World*, vol. 165, p. 19, Mar. 7, 1966.
2. Stringer, L. F., "Thyristor dc drive systems for a nonferrous hot line," *Proc. 1965 IEEE Industrial Static Power Conf.*, p. 40.
3. Kilgore, L. A., Spindle, H. E., and Rice, L. R., "Thyristor converters change HV dc parameters," *Elec. World*, vol. 165, pp. 56-57, Feb. 7, 1966.
4. Kaiser, F. D., "Thyristor converters change HV dc economics," *Elec. World*, vol. 165, pp. 116-117, Feb. 21, 1966.
5. Last, F. H., "British tests with a generator isolated from an ac transmission system and loaded via a dc link," *Direct Current*, p. 162, Nov. 1965.

I. Projected costs for 1000-MW HV dc terminals purchased after 1970

	Mercury	Thyristor
Projected cost per kW (5 years)	\$20.00	\$16.00
Projected efficiency (5 years)	98.80%	98.50%
Penalty, per kW		\$.60
Terminal space required	100%	20%
Penalty, per kW	\$1.00*	
Maintenance and operating personnel ratio	3	1
Evaluation, per kW	\$1.20	\$.40
Evaluated cost per kW		
5-year projection	\$22.20	\$17.00
10-year projection	\$22.20	\$15.40

*This could vary over a wide range, depending on the availability of land.

Trends in digital communication

Pulse code modulation telephony transmission has grown rapidly in recent years, chiefly in short-distance communication applications. Even greater expansion is envisioned as techniques are developed to provide interconnections between PCM and other systems

R. H. Franklin, H. B. Law General Post Office, Great Britain

The introduction and rapid spread of pulse code modulation must be examined in the framework of overall capability, efficiency, and cost. However, apart from television, the only field of application that can presently justify a massive investment in a new transmission system is telephony, because it represents the dominant communication market. Other communication services—such as data and facsimile transmission, telegraphy, broadcast sound, and closed-circuit television—must in general travel as passengers on telephony networks if they are to be economically feasible. Hence, the most fruitful approach to an examination of digital communication is to begin by studying PCM telephony and then to see how other services can be coordinated with it.

Pulse code modulation telephony has been studied for many years and in relation to many types of transmission media. Recently, however, simple market economics have resulted in a great concentration of research and development effort on the production of PCM telephony systems suitable for exploitation of existing voice-frequency cables to provide junction circuits, or interoffice trunks, for distances between, say, 10 and 50 miles (15 and 80 km). Thus over this range PCM telephony is at the present time competitive with VF circuits provided on cables. However, it can be seen from Fig. 1 that 80 percent of the circuits in the British Post Office and Bell Telephone System networks are less than 15 km in length, and very large sums of money are spent on providing circuits in this range using methods that are not very different from those used 30 or more years ago. The circuits utilize metallic conductors, the raw material content of which accounts for a high proportion of the finished price. To date the only economy possible has been through the use of progressively lighter-gauge conductors with loading coils, and negative impedance repeaters for the longer distances. It can be foreseen that the costs of PCM equipment will steadily fall while the raw material element of cables will probably continue to rise, so PCM will be used increasingly for distances shorter than 10 miles. A second attractive feature of PCM is that of expediency; when applied to VF cables already in the ground regenerative repeaters can be installed at 1800-meter (2000-yard) intervals in a relatively simple, straightforward, and quick fashion, as compared with the task of laying and joining a new audio cable.

In some countries PCM telephony for short distances is now in its final stage of development for production on a very large scale; in others, particularly in North America, it is already in mass production and is a standard means of circuit provision. It seems probable that a few years of production, at the present rate, of 24-channel PCM systems to current standards will set a pattern that may determine the future expansion of a digital network for all purposes and for all distances.

Of the messages well suited to being conveyed digitally, possibly the most important, after telephony, is digital data. Existing analog-type telephone networks are being used to carry digital signals in the form of modulated carriers, mainly on VF telephone circuits, at signaling rates between, say, 600 and 2000 bits per second (b/s). A small number of wider-band channels are used at higher speeds utilizing groups or supergroups on wide-band cable or radio links. Use of the analog networks for digital transmission is convenient and expedient, but not very efficient. Furthermore, telephone networks were designed primarily for the transmission of speech, for which certain types of distortion and transient effects, such as impulse noise, can be disregarded. It is difficult and costly to obtain widespread coverage by a data transmission network for speeds of the order of tens or hundreds of kilobits per second (kb/s). The PCM telephony systems, however, lend themselves very aptly to data transmission. The digital capacity of each telephone channel is about 50 kb/s, and the multiplexing of telephone channels by time division produces digital streams of very high signaling rate. A rate of 1.5 megabits per second (Mb/s) is typical of systems now in use, and much higher signaling rates can be envisaged for the future. These digital streams are not immediately available for external connection to data sources, nor can they accept unrestricted codes; in most cases these higher speed digital streams are not binary. A major problem, therefore, is the standardization of interfaces and the production of buffer units operating at defined signaling rates, which allow compatibility between telephony and data.

Integrated PCM switching and transmission systems, in which signals are switched in PCM form without decoding, offer advantages in economy, in quality of overall transmission, and in the possibility of conveying digital data at speeds up to about 50 kb/s in a switched telephone network. These systems could ultimately revolutionize telephony, especially local telephony. At present they are

by wire

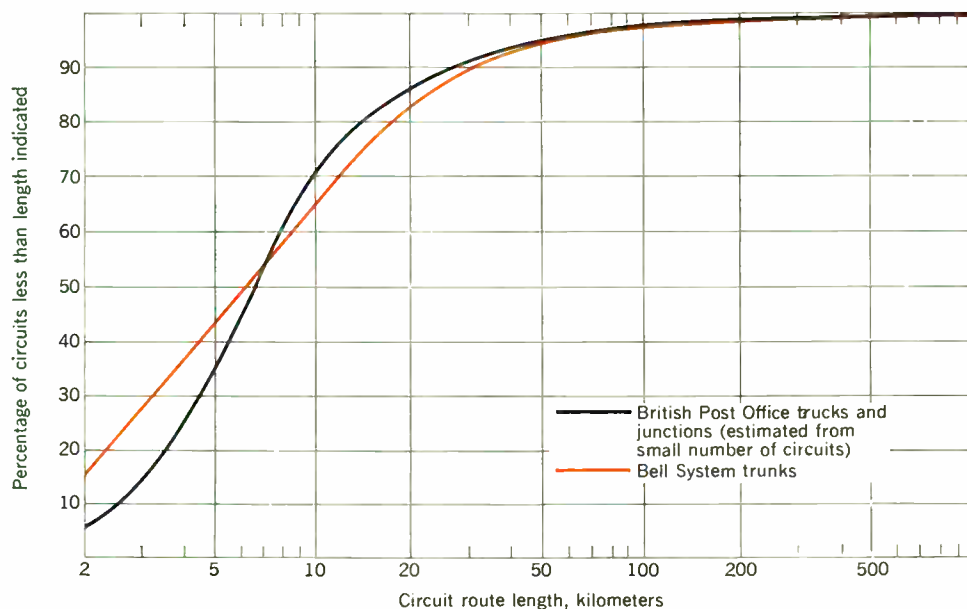

Fig. 1. Length distribution of circuits in British Post Office and Bell System networks.

in their infancy, and point-to-point PCM transmission is setting the pace; consequently, there is a danger that desirable options may be lost unless due consideration is given to interaction between switching and transmission.

Survey of worldwide PCM telephony projects

Voice-frequency cables. The greater part of the VF cable network in any country is concentrated in its cities, where expansion to meet the growing demand for telephone circuits is proving increasingly costly; therefore, methods of multiplying the number of circuits carried by each pair will undoubtedly be more widely adopted. Present indications are that PCM systems offer a satisfactory means of achieving this multiplication.

In PCM systems increased circuit capacity is obtained by time-multiplexing a number of channels on the individual pairs of a cable. An acceptable design objective is that these channels should not provide a worse quality of transmission than the physical circuits they replace. Hence, the bandwidth of each channel is about 3.5 kHz and the resulting sampling frequency about 8 kHz. At this stage in the art, the number of speech channels multiplexed by a PCM system on each pair is usually limited by the type of multipair cable used as the common highway. Considerations of attenuation, crosstalk between pairs, and interference from sources external to the cable decide the spacing of the line repeaters. This decision usually fixes the maximum line speed and thus the number of channels in a system; these appear to vary between 23 and 30 for deloaded cable, with repeaters spaced at about 1800-meter intervals coinciding with the international standard loading spacing. Some parameters of various PCM systems so far developed are given in

Table I. Perhaps the best-known example of such a system is the Bell Telephone Laboratories T1 line system¹ with its associated D1 terminal multiplexing equipment. Worth noting, also, is their T2 line system, which is under development and which is designed to convey a 6.3-Mb/s pulse stream (about four times the line speed of the T1 system) on a VF cable pair with repeater spacing of 1800 meters.

An alternative approach to that just given—one that may prove economic in the future if very-high-speed multiplexing terminals become available—is to consider multiplexing on only a very few carefully selected pairs of a cable and to accept the corresponding reduction in repeater spacing. For example, with only two pairs of a multipair cable, a line speed of 100 Mb/s could provide approximately the capacity of 60 basic 24-channel systems with a repeater at every cable joint (i.e., about 160 meters).

Pair-type twin carrier cables. Some countries have in existence a network of early pair-type twin carrier cables. These cables could be made available in the future for higher-order multiplexing of the basic PCM systems and could also provide high-speed data links. Japan is proposing to multiplex between 10 and 20 basic 24-channel systems on such cables at a line speed, for bipolar pulses, of between 15 Mb/s and 30 Mb/s and using repeater spacing of approximately one km. The British Post Office is investigating the performance of twin carrier cables at frequencies up to 30 MHz. Preliminary results suggest that a line speed of about 10 Mb/s with repeater spacings of one mile (1600 meters) should be feasible.

Coaxial cables. The use of coaxial cables as transmission media may prove to be economic for line speeds in excess of 100 Mb/s. Bell Telephone Laboratories

recently published² details of an experimental 224-Mb/s system capable of simultaneously transmitting, for example, 36 T1 systems, one 600-channel frequency-division multiplex (FDM) mastergroup, and one 525-line television signal. At this line speed it is estimated that, for the two sizes of coaxial cable standardized by the CCITT, line repeaters would have to be spaced at about 1600 meters for the larger and 800 meters for the smaller cable.

It is possible to visualize the development within the next few years of multiplexing systems with bit rates even higher than 224 Mb/s. Such systems will probably be transmitted over coaxial cable systems, necessitating closer repeater spacing, for example, about 500 meters. If such repeater spacing is to prove practicable there will have to be a considerable reduction in the physical size of both repeaters and their containers. Repeaters may be reduced in size by the application of thin-film or integrated circuit techniques to a point where it is not inconceivable that they would be contained within the actual

cable sheath, provided some novel method of satisfying their power requirements could be developed; otherwise it would seem that power supplies may be the limiting factor on repeater size reduction.

The existing method of power feeding along the center conductor of the coaxial cable requires disproportionately large power separation filters at each repeater, and it seems unlikely that these could be reduced to a size commensurate with repeaters suitable for inclusion within the cable sheath. A solution to this conflict might be to supply each repeater with its own compact, primary power unit, which would have to operate for years without attention.

Possible future cables. The transmission requirements of PCM systems are significantly different from those of analog systems and, therefore, types of cable that have proved satisfactory in the past may not be economically feasible for digital transmission. In the single-cable method of operation, in which both directions of transmission are accommodated in the same sheath, it seems

I. Fundamental parameters of 22 PCM systems in various countries

Parameter	Value of Parameter	Number of Systems	Parameter	Value of Parameter	Number of Systems
Sampling rate, kHz	8	All (22)	Degree of approximation	7 segments or less	5
Number of quantization steps	127	1		9 segments, 3:2:3:3	1
	128	19		13 segments	1
	239	1		13 segments, slope ratio 2	4
	256	1		ϕ segments, slope ratio power of 2	1
Channels per frame	24	18		Continuous	7
	30	2		ϕ	3
	31	1	Encoding characteristics	Log, A = 87.6	4
	48	1		Log, A = 114	1
Time slots per frame	24	15		Log, μ = 100	9
	25	3		Log, ϕ	3
	30	1	Derived digitally in ternary	1	
	32	2	Hyperbolic, λ = 20	1	
	48	1	ϕ	3	
Frames per multiframe	1	4	Synchronization method	D	10
	3	1		G	5
	4	10		Out frame	6
	8	3	Bipolar violation	1	
	6/12	1	Signaling method	First in slot	10
	16/32	1		Time sharing	1
ϕ	2	Eighth in slot		10	
Digits per time slot and code at interface	7, SB	1	Out slot	1	
	8, B	10	Load capacity, dBm	0	1
	8, SB	10		+2	9
	10, T	1		+3	7
Gross digit rate, kHz	1536	9		+4	3
	1544	6		+5	2
	1600	3			
	1792	1			
	1920	1			
	2560	1			
Compadding advantage	3072	1			
	18.8	1			
	24.1	5			
	25	1			
	26	8			
	26.5	1			
	26.8	4			
	ϕ	2			

Legend		A characteristic:
ϕ —Not yet decided		$y = \frac{Ax}{1 + \log A}$ $0 \leq v \leq V/A$
B—Straight binary		
SB—Symmetrical binary		$y = \frac{1 + \log Ax}{1 + \log A}$ $V/A \leq v \leq V$
T—Binary coded ternary		
D—Distributed		μ characteristic:
G—Bunched		$y = \frac{\log(1 + \mu x)}{\log(1 + \mu)}$
λ characteristic:		
$y = \frac{(1 + \lambda)x}{(1 + \lambda x)}$		

highly improbable that all the pairs of existing multipair cable can be utilized for PCM transmission, and thus there would appear to be some justification for laying junction cables specifically designed for this purpose. These cables could possibly be of smaller gauge than existing cables, but screening between different layers would undoubtedly be required.

A reduction in the standards to which coaxial cables are built is possible. Present coaxial cables have been developed to meet FDM requirements for telephony, where low-frequency crosstalk between adjacent tubes is important, and for television, which requires electrical uniformity to avoid reflections. In contrast, because of the predominant importance of high frequencies and a greater tolerance of impedance irregularities, multiplexed PCM systems should require cables of radically different construction.

Compatibility and interconnection between FDM and PCM telephony

At the present time, FDM and PCM are developing as separate networks. FDM is typically a long-distance system, and has been developed to permit interconnection of groups and supergroups in the carrier-frequency range without translation to voice frequencies, a facility widely used in normal network planning. The advantage is twofold. First, the use of relatively expensive channel-translating equipment is avoided (the cost of an FDM channel end is roughly equivalent to the cost of transmitting the channel for 500 km on a wide-band system on a heavily loaded route). Second, an improvement in transmission quality and stability results from the elimination of VF connections. The same factors will operate with PCM as with FDM, and it will become necessary, for the same reasons, to avoid VF connections as much as possible. Interconnection in the future, when both PCM and FDM systems coexist in the network, may be studied under three categories—namely, PCM-PCM, FDM-PCM, and PCM-FDM.

PCM-PCM. It is, in principle, possible to transfer the coded signal representing a channel from one PCM system to another, which entails identifying and lining up the time slots in the two systems. This procedure would necessitate the use of delay lines and introduce problems of synchronizing as well as matching of coder and decoder and other internal characteristics of the system. Except in integrated systems, discussed later, it is unlikely that single-channel transfer will have application.

The basic flexibility unit arising naturally in PCM systems is the multiplex frame, comprising a time-division-multiplexed assembly of telephone channels. This multiplex unit is not standardized internationally, and several different formats exist or are being planned (see Table I). Typical among these are systems using 24 channels per frame for the gross digit rate of approximately 1.5 Mb/s. Other systems now in the experimental stage use 30 or more channels with a corresponding increase in the gross digit rate. It seems certain that transfer of complete multiplex frames from one PCM system to another will be required. Indeed, it may be that the multiplex frame of 24 channels (or some other number) will become a fundamental unit in building up higher-speed PCM systems. Standardization of the frame is an obvious requirement. Bell Telephone Laboratories have demonstrated the practicability of multiplexing four 24-channel PCM

assemblies to form an interleaved 96-channel assembly at a gross digit rate of some 6 Mb/s. In principle, further multiplexing could be effected to use the digital capacity of very-high-speed digital coaxial cable links up to some 200 Mb/s. This capacity corresponds to some 3000 telephone channels, which might be built up from the 24-channel assemblies as $24 \times 4 \times 32 = 3072$ channels. At this stage of development any such scheme must be regarded as purely arbitrary. Careful consideration must be given to the most desirable multiplex structure from the point of view of utilization and flexibility. High-capacity digital multiplex assemblies must be capable of being assembled from two different sources: (1) from many independent tributary systems, and (2) from a synchronized hierarchy. The history of FDM is far from logical; a typical 2700-channel arrangement now in use is formed by the product $12 \times 5 \times 15 \times 3$ simply because it grew that way; it is doubtful that this method of assembly is optimal. However, since this arrangement exists, there may be merit in devising a hierarchy for PCM having twice the number of channels as an FDM hierarchy; for example, $24 \times 5 \times 15 \times 3$ has been suggested.³

FDM-PCM. The coding into PCM form of one of the standard FDM assemblies—such as group, supergroup, mastergroup, or supermastergroup—is referred to as FDM-PCM. The digital capacity needed for coding these assemblies of channels is shown in Table II.

It may be noted that some 50 percent extra digital capacity is required to carry coded FDM assemblies than to carry an equivalent number of telephony channels individually coded and multiplexed, and accompanied by their own signaling information.

PCM-FDM. The transmission of PCM digital streams over conventional analog systems, such as coaxial cable links, is called PCM-FDM. This type of transmission is likely to be of value only for short-distance tie systems distributing small blocks of channels. Its applications are extremely limited, because the analog system is essentially one of high dynamic range, which would be very extravagantly used by a PCM system. A different conclusion may be drawn, however, if very-wide-band systems, such as waveguides, should become available in the future. They may provide low-loss transmission paths of very wide bandwidth, but relatively poor quality judged by normal analog transmission standards. Such transmission paths, however, might be well suited for transmission of a PCM signal, frequency-modulated on a carrier in the waveguide range.

Network planning aspects of through connections.

From the point of view of telephony network planning, various possibilities of short-distance and long-distance digital transmission can easily be integrated if they are based upon compatible multiplexing techniques, so that the convenient channel assemblies in PCM form can be extracted and inserted. The network planner, however, is faced at present with a very large FDM network, which connects major centers by means of wide-band systems. Spur routes to low-order switching centers will be provided on an increasing scale by PCM, and it would seem to be a valuable facility if a group or supergroup could be transmitted over a PCM line, where the channels would be extracted by conventional group and channel FDM translating equipment.

It does not seem necessary at present to plan for PCM coding of very large blocks of channels—for example,

900-channel assemblies—because these can be handled by existing FDM systems quite efficiently and economically, particularly when small coaxial cable is used. The position would change, however, if new very-high-speed digital transmission systems (for example, those transmitting several hundred Mb/s) should come into general service.

Data transmission

The interaction between data transmission requirements and PCM telephony systems is likely to be two-way. On the one hand, the existence of PCM short-haul systems will lead naturally to their use for data transmission over relatively short distances and compact areas. On the other hand, once this mode of data transmission has been established, a demand will arise for linking separate short-haul PCM areas by compatible digital transmission means. The result may eventually be intercity digital transmission links primarily to meet the needs of data transmission. Such links are likely to be more economic if they use the PCM type of line plant rather than the existing line plant.

Turning back to the current types of PCM short-haul system, and their use for data transmission, it is useful to consider facilities that might readily be offered by such systems and any resulting problems of standardization.

In a typical 24-channel PCM terminal there are, in principle, three points of access: the digital stream of a channel, a frame, or the line. In the first method, depending upon the means of synchronization and signaling used in the PCM terminal, one or more channel time slots (digital capacity $8 \times 8 = 64$ kb/s) might be made available for an unrestricted data message. Other channels, which would have a digital capacity of $7 \times 8 = 56$ kb/s, might be restricted in use in that certain code sequences could not be allowed. The use of a channel would require that the speed and the timing of the code elements be determined by the multiplex terminal, and some kind of buffer or code converter will generally be needed between the data source and the PCM terminal. It would seem useful to define a binary interface that can operate on any channel without code restriction at a single preferred signaling rate, which must be lower than any PCM multiplex terminal speed; 48 kb/s might be a suitable figure for general adoption.

The use of spare digits associated with frame synchronization is closely associated with particular designs of terminal multiplex equipment. In one particular system, in which bunched synchronization is used, one channel at a fixed rate of 48 kb/s could be made available, subject to the condition that the element timing is entirely dictated by the multiplex terminal.

In existing PCM short-haul carrier systems removal of the telephony multiplex equipment gives, in principle, access to a repeatered line with a capacity of about 1.5 Mb/s. However, there may be serious restrictions on the permissible line signal that will restrict its immediate use for digital communication. For example, the regenerative repeaters would normally operate only over a very narrow range on either side of their nominal rate, so that the input signal speed has to be fairly accurately controlled. In addition, correct synchronization of the repeaters may require some restriction on code sequences—for example, in the maximum time interval between a transition from one condition to another. A broad approach to this problem recognizes two possible techniques:

(1) to design the most efficient and economical line system for PCM telephony signals and (2) to design a general-purpose line system for unrestricted code signals.

Although, in the foregoing discussion, only data transmission has been considered, the application of PCM telephony systems to other forms of digital communication will be obvious. Telegraph message transmission can be carried far more economically on such systems than on present VF systems, which have, at most, a capacity of $24 \times 75 = 1800$ b/s per voice channel. Considerable possibilities exist of subdividing, to form many telegraph channels, the 56-kb/s capability corresponding to a single channel on a PCM system. Integration of such multiplex telegraph systems with computer-controlled message-switching systems is a further possibility.

Integrated systems

The development of practical PCM transmission has led to increasing interest in switching systems for PCM signals. These systems show the normal advantages of time-division switching in saving of crosspoints and simplification of trunking but, because of the robust digital signals, they are much less susceptible to the noise and crosstalk troubles that affect time-division multiplex (TDM) exchanges using pulse amplitude modulation. If the majority of lines associated with an exchange are of the PCM type, it may be economical to use a compatible PCM switching system, saving coding/decoding equipment and also reducing loss (because switching is four-wire) and quantizing noise on connections through the exchange. An integrated PCM switching and transmission system for telephony offers facilities for handling high-speed switched data and thus much of the interest in integrated systems has been in military applications. Here we are concerned primarily with civilian developments.

The early Experimental Solid State Exchange (ESSEX) experiment⁴ illustrates one application of integrated systems in which there is a strong continuing interest.^{5,6} Here customers were served by concentrators, which were in turn connected via PCM links to a central switch and controller. This arrangement could bring the advantages and facilities of a large central controller to remote customers who would otherwise be served by a small exchange, providing only simple facilities economically.

Perhaps the most promising initial application for PCM switching is in large cities,⁷ where a proportion of the traffic between local exchanges is switched, via tandem exchanges, as shown in Fig. 2. The links or junctions between a tandem and the local exchanges are likely candidates for conversion to PCM transmission, and thus PCM switching at the tandem exchange would become attractive. PCM switching might then spread

II. Estimated digital capacities for coding FDM channel assemblies

Number of Channels	Number of Levels	Sampling Frequency	Total Digital Rate, Mb/s
12	10	112 kHz	1.12
60	9	592 kHz	5.3
300*	9	4.1 MHz	36.9
600†	9	6.176 MHz	55.58
900‡	9	8.1 MHz	72.9

* CCITT basic mastergroup
† LI mastergroup
‡ CCITT supermastergroup or 15-supergroup assembly

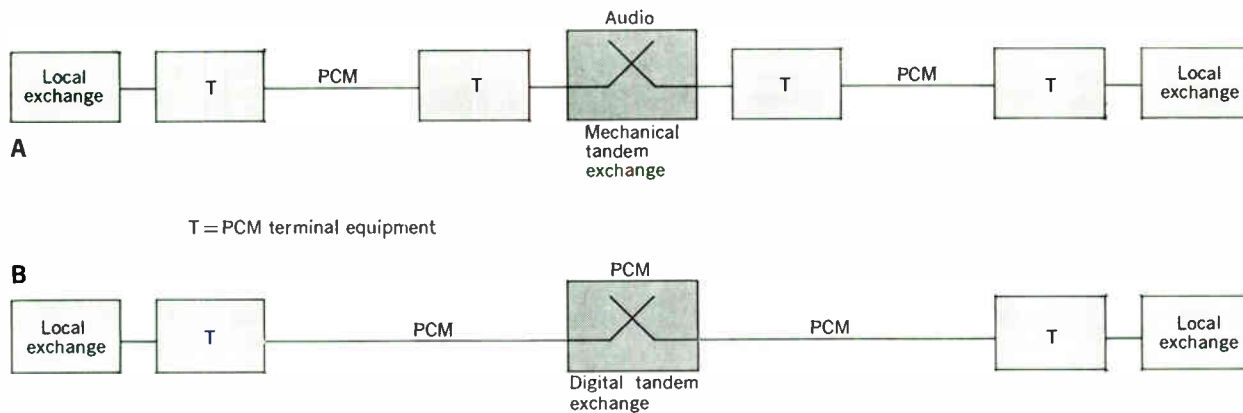

Fig. 2. Tandem exchange switching (A) before and (B) after introduction of digital switching.

both upwards and downwards in the network, toward the trunk system and toward the customer.

Compared with the use of PCM purely for transmission purposes, integrated systems pose some new problems, such as network synchronization and coder/decoder compatibility, and they may profoundly affect some old ones, such as signaling arrangements. So the transmission and switching requirements interact and, with development in the present early stage and with technology advancing rapidly, the aim should be to preserve as much freedom as possible for evolution.

Integrated PCM may perhaps be the system of the future, but in civilian applications it will be relatively uncommon for some time to come. For it to succeed it must, for many years, coexist and interwork with present systems, and do so profitably.

Coder/decoder compatibility. Close matching of coder/decoder characteristics, which in any event is desirable for flexibility in the use of PCM multiplex equipment, is essential in integrated systems where any coder may have to interwork with any decoder. By reducing the number of coding/decoding operations contributing quantizing noise to a connection and by reducing the range of signal levels to be accommodated, a fully integrated system may eventually allow some relaxation in coder/decoder requirements, perhaps even to the extent of allowing fewer digits to be used. In the meantime, integrated system requirements must follow those under study for point-to-point transmission systems. An instantaneous compander characteristic composed of linear segments is easy to specify and gives some freedom in method of realization.

Synchronization. The ESSEX experiment exposed one of the main problems in an integrated PCM network, that of timing or synchronization. A star configuration was used, with a central switching system serving a number of remote concentrators; the entire system was controlled by a master clock at the center. Delay changes in the lines, caused by cable temperature variation, were compensated by servo-controlled delay lines.

In a large network, especially one containing meshes, dependence upon a single master for synchronization is objectionable for security reasons. In one of the two techniques available, the exchanges are controlled by stable clocks but no attempt is made to keep them in synchronism⁸; the channels of the transmission systems are controlled by the clocks at their sending ends. At the

receiving end, the digital information controlled by the remote clock is staticized in a buffer store and read out into the receiving exchange in local clock time. From time to time, as the clocks drift, a store may be rewritten before it has been read or it may be read before the next word has been written. Thus words occasionally are lost or dummies are inserted. With practicable clock stabilities these events are rare; for example, a frequency difference of one part in 10^7 gives an interval of 20 minutes between slips with the normal 125-microsecond frame. Even with several exchanges contributing, such a rate of slip would be of no significance for speech; data transmitted through the system would have to be appropriately protected, with some loss of speed in consequence.

Alternatively, a network may be operated isochronously with exchange clocks all of equal status, to avoid the security risk of having a master,⁷ and with some form of 'democratic' control to keep the clocks synchronized. With this arrangement, comparatively small buffer stores are required for the received signals, to allow for line delay variations, perhaps 8 bits compared with 192 bits for a 24-channel, 7 + 1 digit, asynchronous system. Thus there is a saving of exchange peripheral equipment for every line, to the benefit of economy and security, at the expense of a more elaborate system of clock control. The control system must be stable, free from objectionable hunting, and able to withstand local shocks or even disasters without having the trouble spread through the network.

The problems of isochronous operation increase with the physical size of the network and they may well prove insuperable for very wide areas and, especially, for international use. A hybrid arrangement is an obvious possibility, with isochronous local networks interconnected asynchronously via links incorporating buffer stores. An important question is: How big an isochronous network is appropriate economically and operationally?

Slot changing and frame structure. A call coming into a PCM exchange in a certain time slot of the multiplex may find that the time slot is already occupied and thus is not available in the desired outgoing direction. Therefore, a facility for slot changing within the exchange is required to reduce blocking. Typically, some 40 percent of the traffic can be carried without slot changing.⁹ A

large exchange serving 10 000 junctions (such as might be used for tandem switching in a very large city) might have three stages of switching with slot changing by means of stores or delay lines incorporated in the central switching stage.¹⁰ In an exchange of the asynchronous type, the peripheral buffer stores can, with appropriate access arrangements, contribute to the slot changing.

For simplicity within the exchange it is necessary that the TDM frame, normally of 125-microsecond period, be divided into an integral number of channel time slots—for example, 24. To avoid clocking complications and unnecessary buffer storage, a directly compatible frame structure is desirable for the line signals; from this standpoint, the practice of including a single synchronizing bit in a frame otherwise composed of 8-bit channel words seems unfortunate.

Signaling. Another point of interaction between line and switching requirements is in the method of signaling. It is a common practice to include an additional digit in the channel word—giving, typically, an eight-bit word, with seven digits for speech and one for signaling. What position should the signaling digit have in the word, first or last? Should the signaling digits be time-divided?

Some purely internal signaling is required within an exchange for control purposes, particularly to maintain the holding condition in the memories controlling cross-points. In an exchange organized for serial transmission of the bits comprising the channel words, the hold digit may be included in the channel word, most conveniently by time sharing with the normal external signaling function. The external signaling code structure must permit time sharing within the exchange. In addition, the signaling digit must be the first in the word, so that the local hold (or rewrite) instruction arrives while the cross-point address code is in use and is therefore available for rewriting without additional storage. The first requirement, for time sharing within the exchange, is compatible with time sharing between signaling and synchronizing on the line.

Straightforward time division of the signaling digits to give several independent signaling channels per speech channel is attractive in purely transmission applications of PCM, but within an exchange special measures would be necessary to avoid corruption of the signaling information due to slot changing. Rhythmic signaling codes that depend on the recognition of a repetitive pattern, though less efficient, may be preferable for integrated systems.

Use of “out-slot” or “order-wire” signaling, or parallel instead of serial transmission, would of course reduce the force of this argument, but while systems are evolving, unnecessary restrictions imposed by transmission practice on switching, and vice versa, should be avoided. Since transmission is ahead of switching in development and application, the main danger is that switching may be prejudiced by prior choices in transmission systems.

Conclusions

This article has briefly outlined the current trends in digital transmission systems. Although the present emphasis is on short-distance PCM applications to telephony as a straight replacement for VF cable circuits, the possibilities for the future seem able to embrace all distances and all types of messages.

There are at least three areas where standardization of certain characteristics may be useful and important.

First, it would be useful if interfaces were established, associated with multiplex terminals, which would allow the designers of the data, facsimile, and telephony systems to optimize their systems independently. An interface corresponding to one channel of the order of 50 kb/s, and an interface corresponding to one digital line, of the order of 1.5 Mb/s, seem the minimum objectives.

Second, the problems of interconnection between one PCM telephony system and another, and between PCM and FDM telephony systems have to be studied. In this study it would be prudent to assume that long-haul PCM systems will develop; moreover, the system of multiplexing ought to have a measure of common structure with that of short-haul PCM systems. The principal aim is to facilitate the transfer of blocks of channels from one system to another in large and small bundles without the need for audio-to-audio connections. The need seems to be for an ordered hierarchy in PCM assemblies with, say, two or three levels directly compatible with established FDM assemblies, such as supergroups, mastergroups, and supermastergroups.

Third, the possibility of integrating switching and PCM transmission systems is an attractive one for local telephone traffic in the centers and suburbs of big cities; in this application, integrated systems will be of greatest benefit to customers and will carry the most traffic. Too-early standardization of PCM telephony systems and overemphasis on the need for compatibility between the short-distance requirements, which are known, and long-distance requirements, which are not known, can prejudice an optimum solution for the metropolitan integrated system. It may be that an artificial boundary between the two classes of services has to be accepted, with the long-distance systems bearing the cost and complexity of conversion at the boundary.

Revised text of paper 19CP66-1101, presented at the IEEE International Communications Conference, Philadelphia, Pa., June 15-17, 1966.

Acknowledgment is made to the engineer-in-chief of the British Post Office for permission to publish information contained in this article.

REFERENCES

1. Fultz, K. E., and Penick, D. B., “The T1 carrier system,” *Bell System Tech. J.*, vol. 44, pp. 1405-1451, Sept. 1965.
2. Mayo, J. S., “Experimental 224-Mb/s PCM terminals,” *Bell System Tech. J.*, vol. 44, pp. 1813-1841, Nov. 1965.
3. Kumagai, D., and Kurahasi, Y., “Multiplexing and flexibility in PCM systems,” *Rec. Elec. Commun. Lab. (Tokyo)*, vol. 13, p. 811, Oct. 1965.
4. Vaughan, H. E., “Research model for time-separation integrated communication,” *Bell System Tech. J.*, vol. 38, pp. 909-932, July 1959.
5. Pinet, A., Martin, J., and Revel, M., “Systèmes de commutation électronique temporelle,” *Commutation Electron. (Paris)*, no. 12, p. 22, Mar. 1966.
6. Edstrom, N., “A telecommunication system with integrated switching and transmission media,” *Proc. 1966 Internat'l Conf. on Electronic Switching (Paris)*, to be published.
7. Duerdoth, W. T., “The possibility of an integrated PCM switching and transmission network,” *Proc. 1966 Internat'l Conf. on Electronic Switching (Paris)*, to be published.
8. Dumosseau, C., “An integrated PCM network,” *IEEE Trans. on Communication Technology*, vol. COM-13, pp. 42-49, Mar. 1965.
9. Walker, E., and Duerdoth, W. T., “Trunking and traffic principles of a PCM telephone exchange,” *Proc. IEE (London)*, vol. 111, pp. 1976-1980, Dec. 1964.
10. Harding, D. J., “An approach to a tandem exchange for an integrated PCM network,” *Proc. 1966 Internat'l Conf. on Electronic Switching (Paris)*, to be published.

Ocean engineering: food fish for a hungry world

Electronic techniques—and ingenuity—are being applied for supplying an increasing world population with a valuable source of protein. A compendium of the task capabilities of deep-diving submersibles is presented, and a critical evaluation is made of the U.S. efforts in ocean exploitation

Gordon D. Friedlander Staff Writer

In recent years, the fish harvest from the oceanic waters of the world has increased annually about eight percent by weight. Projected estimates indicate that the present yearly catch of food fish could be multiplied ten times without endangering the total edible marine population. Certain seacoast waters have been depleted of their food-fish supply because of unscientific overexploitation. The Japanese and Russians, in particular, have been expanding their localized fishing efforts to encompass worldwide ocean areas. To ensure continued improvement in the science and technology of catching fish in large quantities, new developments in underwater television; FM sonar; and net construction, control, and handling are imperative. And the accurate tracking and charting of the migratory habits of large schools of food fish are equally important in predicting future and seasonal areas of bountiful supply.

Over the centuries fisherman have sought practical—and, more recently, scientific—means for improving their catch of food fish. For sea-bordering countries such as Norway, the United Kingdom, Japan, and Portugal, whose topography is not adaptable for extensive agriculture or cattle raising, or where a huge population in a limited territorial area makes it impossible to obtain sufficient food from land resources, the protein supply from the sea has literally spelled the difference between adequate food and famine.

The Japanese were perhaps the first to utilize—through sheer necessity—an indirect application of electronics in a quasi-scientific effort to increase their fish catch.

The 'radio grid'

After World War II, a defeated and devastated Japan had to improvise unusual and ingenious techniques to acquire sufficient food for the sustenance of nearly 100 million people crammed into an island land mass of

approximately the same area as the New England states plus New York. Since most of their rice stores, crops, and agricultural facilities had been destroyed, the Japanese turned intensively to their traditional source of survival—the sea.

To ensure that trawler fleets would return from coastal fishing grounds with the maximum possible catch during the seasons when tuna, albacore, and other food fish were running, simple rectangular grid systems were marked out by buoys. As shown in Fig. 1, each trawler of the fishing fleet was assigned a square (which might measure 10 by 10 km) as its fishing station. A mother ship, anchored outside the perimeter of the grid, maintained two-way radio communication with each vessel.

At regular time intervals, each trawler would report the weight of its catch by radio, and this information would be plotted on a chart aboard the mother ship. When it was apparent that one or more squares in the grid were yielding a maximum or heavy catch, trawlers in adjacent squares, where the take was light or moderate, would be directed to proceed to the squares that indicated a heavier fish concentration.

The day-to-day and seasonal records that were kept eventually permitted a rough pattern of school fish migration in coastal waters to emerge. This simple and effective pioneering effort served as the forerunner of the more sophisticated electronic techniques that have since been developed.

Role of marine biology

The U.S. Bureau of Commercial Fisheries maintains laboratories and installations situated at coastal points around the perimeter of the continental United States. The bureau, a branch of the Department of the Interior, has long been interested in marine scientific research and supplying vital information to commercial fishermen.

Paradoxically, despite our vast contemporary knowledge of many areas of science, oceanographers have

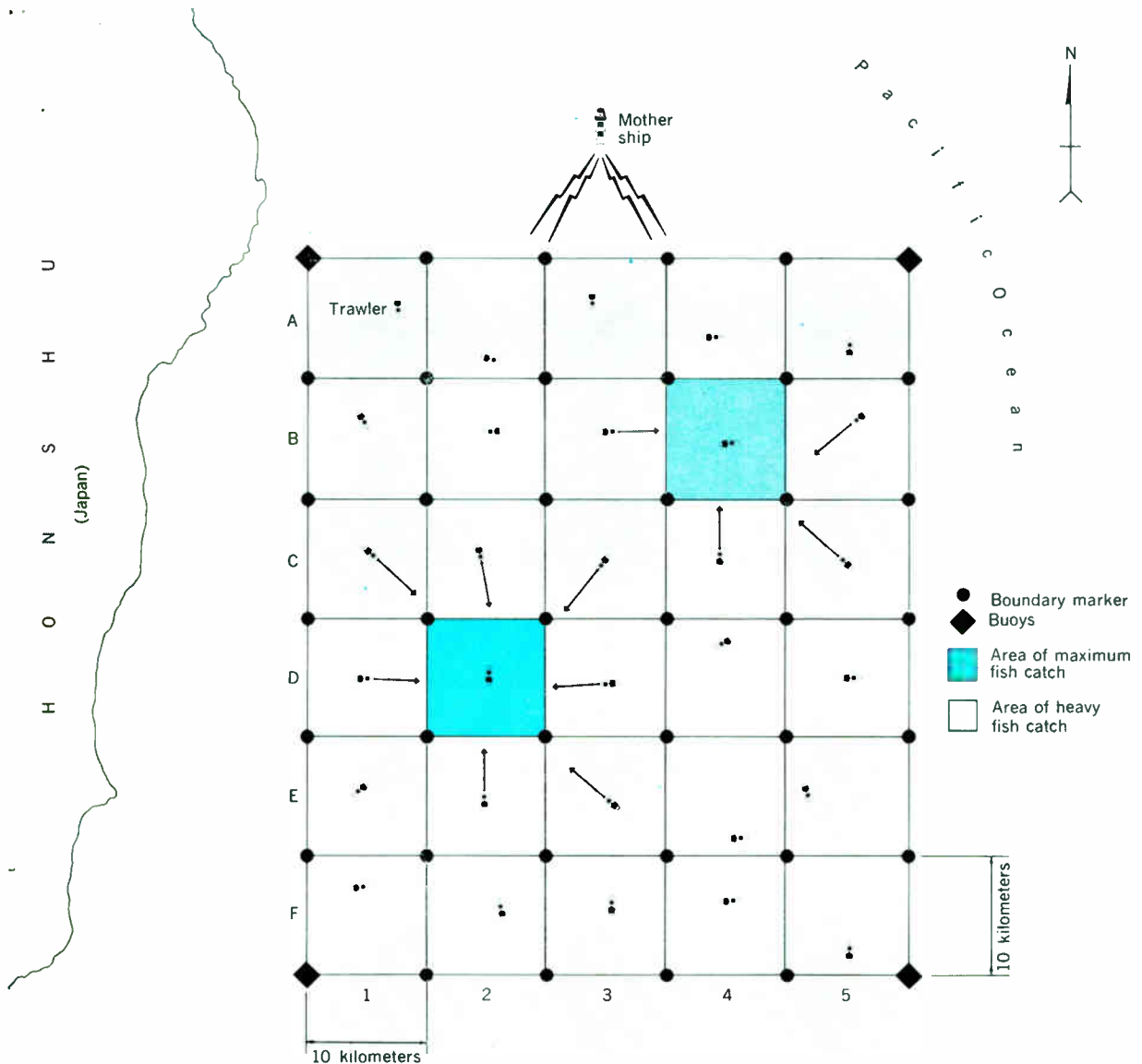

Fig. 1. The "radio grid" system used by Japanese fishing fleets to establish, by Cartesian coordinates, the areas of heavy and maximum fish catches.

"barely scratched the surface" in learning the physical facts about the oceans of our sea-girt planet. If this seems a bit incredible, a statement by Dr. Robert L. Edwards, assistant director of the Woods Hole Marine Biology Laboratory, appearing in the May 1966 issue of *Monsanto Magazine*, may be highly significant: "Right now the marine biologist is like a person wearing gloves, trying to describe an apple in the center of a barrel. He can't see the apple and can't really feel it." In the same issue, Dr. Herbert W. Graham, the director at Woods Hole, emphasized the laboratory's primary function "to describe the distribution and abundance of commercially important marine species in time and space, and to study the environmental factors which affect these species."

To implement these efforts, Woods Hole has acquired a \$2 million stern-ramp trawler (Fig. 2) that is equipped with enough electronic gear and scientific apparatus to make the vessel a fisherman-biologist-oceanographer's

dream come true. The craft is primarily designed for fishery research and secondarily for making oceanographic observations.

When the "cod end" of the huge nylon otter net is hauled over the stern ramp, an initial section of captured fish is made on the after trawl deck (Fig. 2). Fish selected for tagging or study are taken into the "wet" laboratories, which are equipped with tanks to transport live specimens back to Woods Hole if necessary. Hydrographic and chemistry laboratories on board are used for the study and analysis of sedimentary and marine life bottom samples that are collected during each cruise.

Bright red or yellow plastic disks (with instructions to fishermen to report back to Woods Hole the location, weight, and date of the tagged catch) are attached to a predetermined number of migratory fish such as tuna, haddock, cod, halibut, sea bass, dogfish, and skate. The tagging program has produced vital and valuable data in identifying fish groups and schools, and the migratory range and growth rate of food fish. A yellow plastic disk, returned from the U.S.S.R. in 1964, set a

time-lapse record for the tagging program. It was taken from a haddock that was tagged in 1958.

Fish and the ocean environment

One theory advanced by the U.S. Bureau of Commercial Fisheries¹ is that changes in the ocean environment—sea temperature, currents, etc.—cause major fluctuations in the distribution and abundance of fish in any geographical ocean area (see Fig. 3), and thereby affect the annual fish catch. Generally, the catch of bottom-swimming fishes such as cod, haddock, flounder, sole, and halibut varies the least during periods of environmental change. But the pelagic, near-surface-swimming and school fishes, such as tuna, albacore, mackerel, and herring, fluctuate greatly in abundance and in distribution during these periods. The latter group of schooling fishes are of the true migratory type and never remain in the same ocean area, in large concentrations, for any length of time either within a season or from year to year.

Changing ocean conditions. Although high cyclic infant mortality rates and other biological factors in certain species account for some measure of the catch fluctuation, many oceanographers and marine biologists now believe that changing ocean conditions—particularly temperature—may be a prime reason for the strange catch patterns.

To human beings and other warm-blooded mammals, with a physiologically controlled internal temperature and the further protection afforded by clothing, fur, or shelter, a temperature change of a few degrees seems insignificant. But to cold-blooded animals such as fish, whose temperature is governed by their environment, a temperature variation of a few degrees greatly affects their metabolism, activity, and the amount of food required to sustain their energy levels. Thus it is both natural and logical for these creatures to evolve habits, reactions, and migratory patterns that tend to restrict some species to a relatively narrow range of temperature differentials. And each species changes its location to remain within its optimal temperature range.

The U.S. Bureau of Commercial Fisheries noted a significant change in the surface temperatures of the North Pacific Ocean from 1956 to 1957, and the distribution patterns of tuna-like fish were quite different in 1957 from those of the immediately preceding years. Although this evidence was too sketchy to be conclusive, since there are numerous influencing factors in addition to temperature, it did provide a clue for further investigation and analysis under controlled laboratory conditions.

Ocean-monitoring system. Dr. Oscar E. Sette, of the U.S. Bureau of Commercial Fisheries Laboratory in Stanford, Calif., believes that a comprehensive ocean-monitoring system is required for quantitatively measuring the variables of temperature, salinity, oxygen concentration, water clarity, etc., throughout the three-dimensional environment of the sea. Only by the exhaustive acquisition of such data, which will also be of great interdisciplinary value to meteorologists, physical and biological oceanographers, radiologists, military scientists, and other sea-oriented groups, will our understanding and knowledge of the oceans be advanced to the point where accurate forecasting—perhaps based on computer data processing—on the distribution and abundance of food fish be achieved.



Fig. 2. The U.S. Bureau of Fisheries' specially designed research vessel, "Albatross IV," is the first stern-ramp trawler built in the United States. The ship is completely equipped with biological and chemical laboratories for the acquisition of marine scientific data.

Sette conceives of a basic monitoring network for gathering these vital data that includes

1. Weather ships on station which, in addition to transmitting marine weather reports every six hours, are provided with improved electronic instrumentation for measuring near-surface sea temperatures.
2. Equipping selected weather ships with expendable bathythermograph (XBT) systems to probe the ocean through the mixed layer and down to depths of 600 to 1000 meters that are well into the permanent thermocline.
3. Automatic deep-anchored buoys, situated in areas outside the regular steamship lanes, for measuring atmospheric conditions, and equipped with a string of sensors for measuring water properties at various levels down to 600 meters.
4. Supplementary tide stations (in addition to those already in existence), strategically situated with reference to the world's major ocean currents.
5. Aircraft equipped with infrared temperature sensors, and perhaps XBT capability, for making overflights of critical areas that are not otherwise monitored. (The application of such an overflight will be discussed subsequently.)
6. Cloud-cover charts assembled from satellite photographs.

This system should serve to accelerate the progress toward an adequate understanding of atmosphere-ocean and fish-ocean environmental relationships.

Eastern seaboard overflight project. An overflight project was recently initiated, with the cooperation of the United States Coast Guard, sponsored by the Sandy Hook Marine Laboratory of the Department of the Interior's Bureau of Sport Fisheries and Wildlife. Its mission is to correlate sea temperatures with the migration of fishes and to conduct a visual census of near-surface-swimming marine life.

The sea temperatures are taken by infrared sensing devices installed above a special two-piece "Dutch door"—somewhat analogous to a bomb bay—fitted into the belly

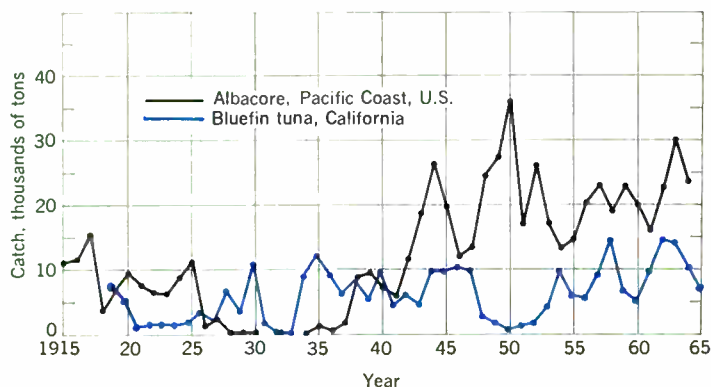

Fig. 3. Graphic plot showing the marked fluctuations in the catch of albacore and bluefin tuna off the west coast of the United States during a 50-year period. The statistical reports of the U.S. Bureau of Commercial Fisheries are the source of data for these graphs.

of a Coast Guard amphibious plane. As the aircraft flies at a speed of 240 km/h and at altitudes ranging from 60 to 180 meters above the sea, the sensing device, aimed straight down through one half of the Dutch door, records the sea surface temperature in red ink on a graphic display. The scientists aboard shout what they read into a tape recorder that is synchronized with carefully predetermined flight courses that range from a kilometer or two off the New Jersey coast to 300 kilometers out to sea.

Figure 4 is a map of a typical overflight off the New York–New Jersey coastal areas. On the initial flight of the project, the airborne observers counted 84 sharks, four whales, two large schools of tuna, 24 sea turtles, two large rays—and a submerged submarine.

The secondary phases of the flights involve the checking of surface and ocean-bottom currents to determine their directions and speeds. To obtain these data, the flying scientists periodically—at precisely established coordinates—drop watertight floating bottles that contain a card with the following imprinted message:

“Reward. Remove card from bottle; please fill in information as indicated and send by mail: Where found (name of beach, near what Coast Guard station, lighthouse, or other prominent reference point). When found. Your name and home address.” The reward to the sender, after receipt of the card at Sandy Hook, is \$0.50.

To determine the bottom current speed and direction, umbrella-like devices of yellow plastic attached to a long, red plastic tube are jettisoned at timed intervals from the aircraft. A round cake of salt, affixed to the lower end of the tube, carries the device to the ocean bottom. As the salt dissolves (producing a condition of neutral buoyancy), the “parasol,” with holes in its surface, does a hopscotch dance over the sea floor until the salt cake is entirely dissolved; then a slight positive buoyancy will eventually carry the device to the surface.

The parasol experiment is sponsored by the Woods Hole Oceanographic Institute, and markers, requesting information from finders, are attached to each device. Scientists at Woods Hole report a 15 percent return of this equipment.

The overflights in the New York–New Jersey coastal

areas herald the eventual extension of the surveys from Cape Cod to Florida.

Sonic tracking of large fishes

In the American classic, *Moby Dick*, Captain Ahab tracks the white whale across three oceans by a strange combination of his vast experience, acquired over many years of whaling, and an almost mystical blend of pathological hatred and intuition that drives him inexorably on to the fatal rendezvous. For more than a century oceanographers, including Lieutenant Matthew Maury, U.S.N., the father of modern oceanographic science, have speculated on the possibility that cetaceous mammals and large schools of food fish may follow the paths of the great ocean currents such as the Gulf Stream, the Kuroshio (Gulf Stream of Japan), the Humboldt, and the Labrador. Today, as previously mentioned, we have some evidence that various species of fishes may migrate under the influence of changes in sea surface temperatures. Therefore, if the century-old hypothesis is valid, tuna, haddock, and albacore follow the currents and are, in turn, pursued by the cetacean mammals (whales, porpoises, and dolphins), which feed upon them.

We now know, as Herman Melville’s novel indicated, that it is not uncommon for whales to circumnavigate the globe in their fantastic migratory journeys made during the course of three to four years.

A pioneering effort. Several years ago, scientists of the U.S. Fish and Wildlife Service and the American Museum of Natural History began developmental work on devices that would enable them to follow the untethered movements of large fish, with respect to both short-term maneuvering and their long-term migratory travels, in the ocean environment.² Prior to 1959, limited sonic tracking of salmon had been done in rivers over short distances and time periods.

Sonic tracking under oceanic conditions, however, entails far greater distances and time duration. Also, because of miniaturization problems in designing a transmitter unit with a minimum transmission capability of 150 hours, the device could only be used on fish weighing more than 115 kilograms (250 pounds).

System specifications. The sonar system consists of four basic components: a transmitter attached to the fish, a shipboard receiver, two underwater hydrophones, and a special sensitive sensor for use near the range limit of the instrumentation.

The transmitter is contained within a watertight aluminum capsule 260 mm long by 64 mm in diameter (see Fig. 5) that has a barium titanate transducer molded into the head end. The device, weighing 960 grams (34 ounces) in seawater, is designed to withstand depths of about 300 meters. An ultrasonic tracking signal, with a frequency of 38 kHz and a pulse duration of 50–100 ms, is radiated at the rate of one pulse every two seconds. Power is provided by a 13-volt mercury battery that gives an input of 12 watts to the transducer for 150 hours.

Two barium titanate receiving transducers in this configuration are aboard the tracking vessel and are installed adjacent to a dual-channel low-noise narrow-band pre-amplifier. The transducers are mounted (Fig. 6) in a 3-meter-long boom which is faired out along its lower two meters to provide a smooth hydrofoil section when submerged. The devices, whose horizontal axes are oriented at right angles to each other, are molded in rubber and

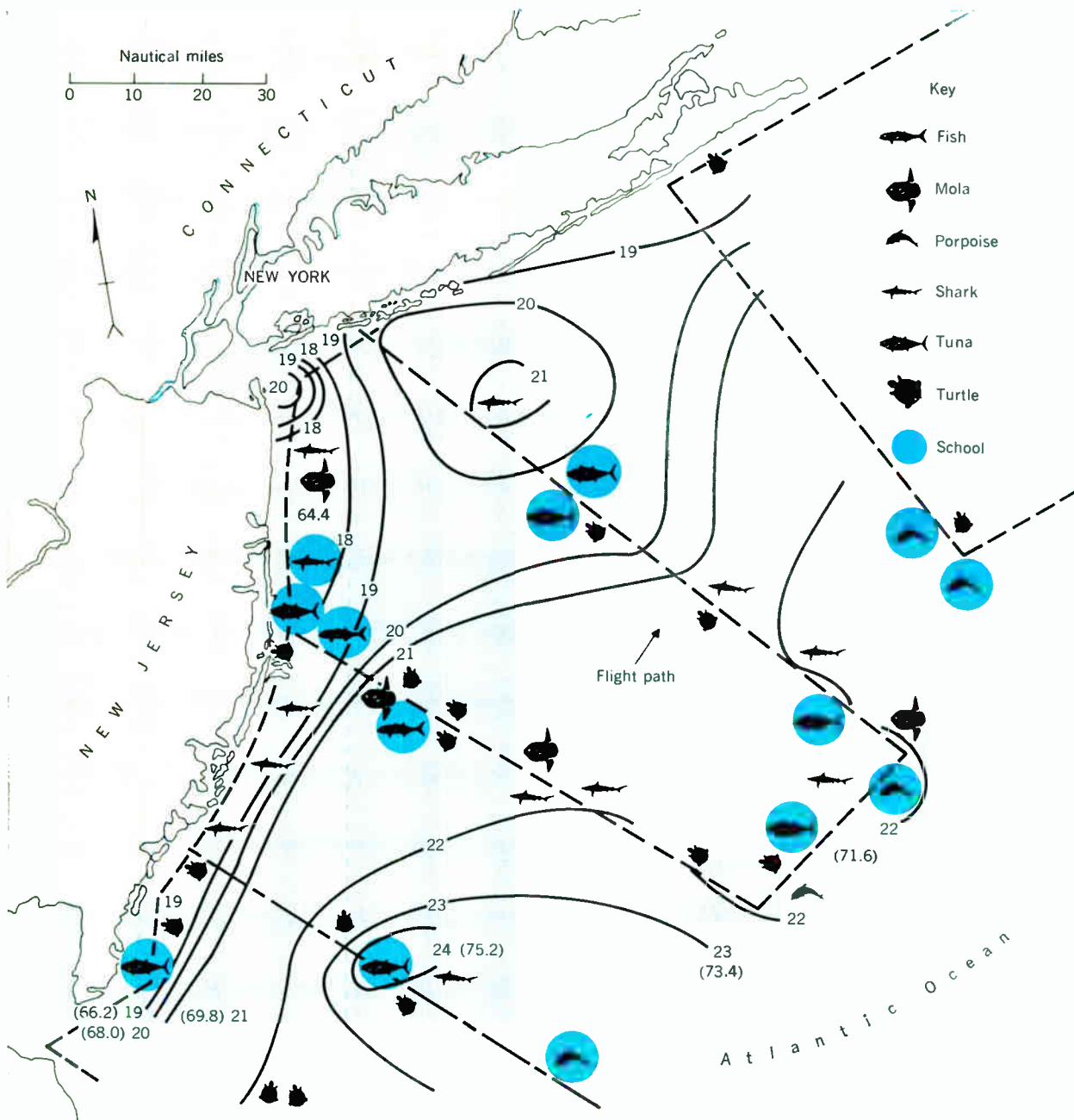
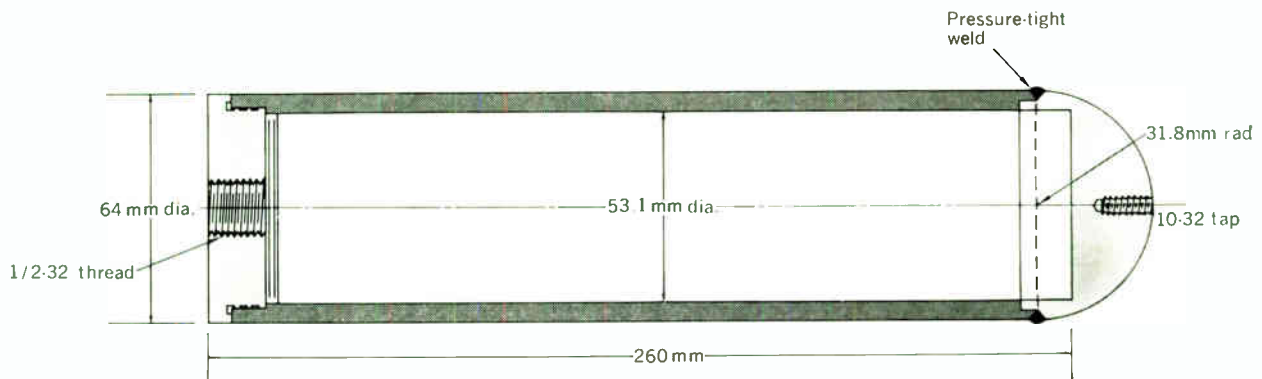

Fig. 4. Map of a typical overflight off the New York–New Jersey coastal areas. Contours represent isothermal lines of water temperature calibrated in degrees Celsius and Fahrenheit.

Fig. 5. Cross section showing construction of the submersible sonic tag unit, capable of transmitting signals at a depth of 300 meters.



are surrounded by sound-absorbing material. The transducers are adequately unidirectional in their response and they are connected to the input of the preamplifier.

The preamplifier, which carries its own battery power supply in the upper half of the boom to reduce extraneous noise, has a usable input sensitivity of 2 microvolts, with low-impedance outputs to match the 50-ohm coaxial cable that connects it to the shipboard receiver unit. In operation, the boom unit is mounted vertically in the bow of the boat and attached to a special "harpoon pulpit" structure to keep its lower end submerged forward of the bow wave and at a level of 1-2 meters beneath the surface of the water.

The shipboard receiver is contained within a spray-

proof metal cabinet and all operating controls are mounted in a readily accessible subpanel. A 12-volt battery powers the unit and its accessories. To match the preamplifier characteristics, the receiver also contains a dual-channel narrow-band amplifier with low-impedance output, and it is completely shielded to minimize extraneous noise from the boat's electrical system.

A zero-centered meter provides a visual readout that gives directional information by deflection either to the left or right, and a second meter indicates range by measuring signal strength. A set of stereo headphones provides aural signals that supplement the visual display.

The system configuration shown in the Figs. 7 and 8 diagrams is primarily designed for installation in small

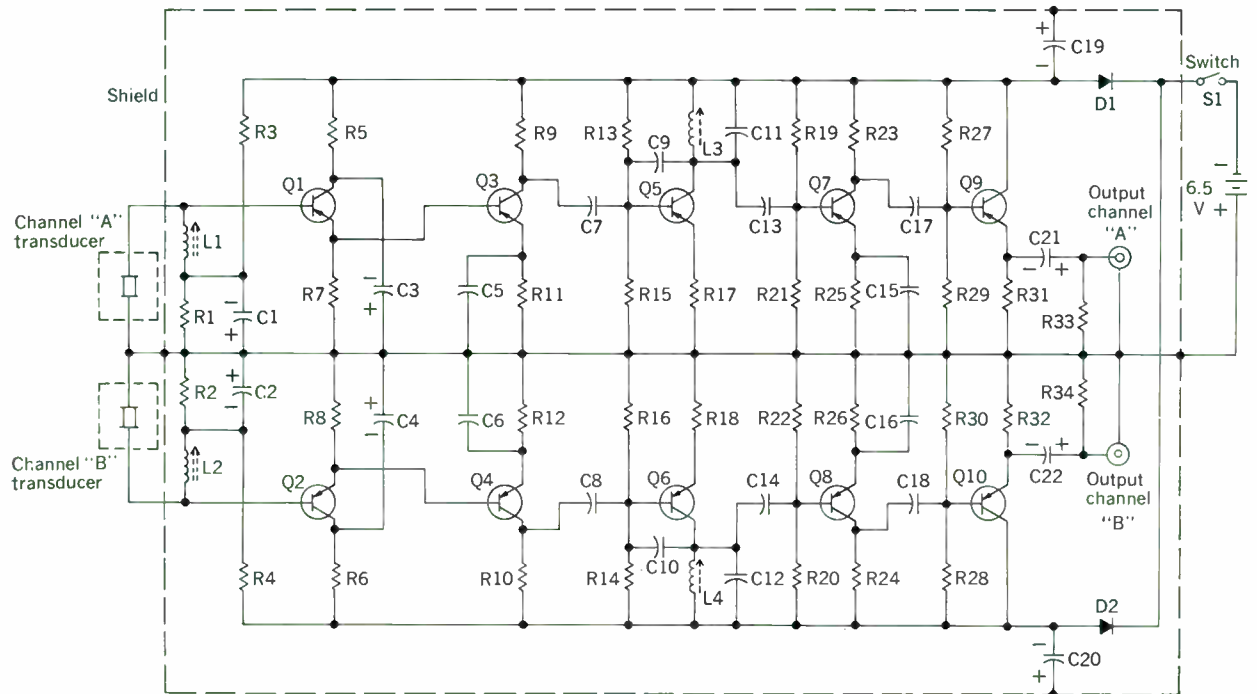

Component parts list

C1, C2, C3, C4, C19, C20, C21, C22 — Subminiature electrolytic capacitor
 C5 through C8, C13 through C18 — Ceramic disk capacitor
 C9, C10 — Molded mica capacitor
 C11, C12 — Molded plastic capacitor

D1, D2 — Silicon diode
 L1 through L4 — Adjustable inductor
 Q1 through Q10 — Germanium p-n-p transistor
 R1 through R34 — Molded composition resistor

Fig. 6. Diagram showing components of the underwater part of the receiver.

Fig. 7. Block diagram showing all shipboard and underwater elements of the sonic-tracking configuration.

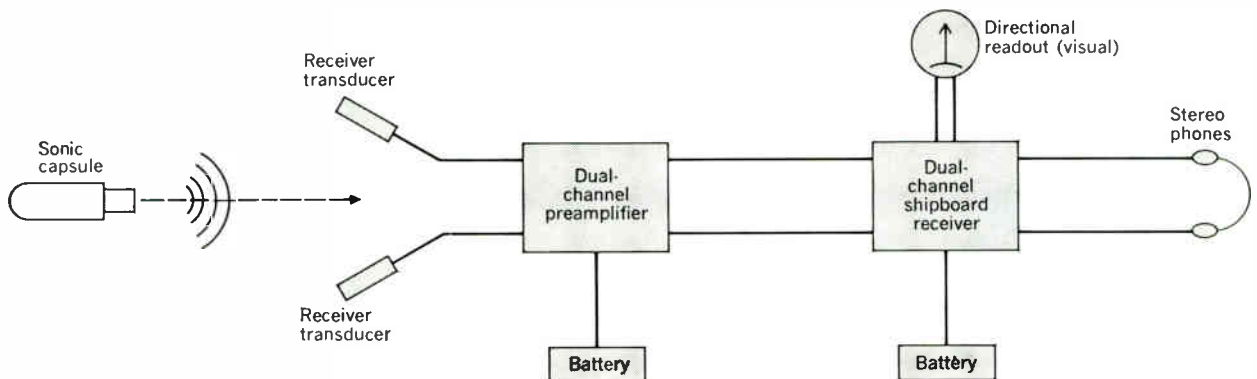

cruisers of the sport-fisherman type. The self-contained power feature makes the operation of the sonic system independent of the boat's electric power supply.

System performance. The overall performance of the described configuration is sufficiently satisfactory for a range of more than two kilometers in a moderate sea state, and at vessel speeds of up to 20 km/h. Although the range may be increased up to 16 km by boosting the power output of the transmitter, this will greatly reduce its operating life.

When the signal is either lost or becomes too marginal for determining an accurate bearing, a hand-held "snifter" device, consisting of a single-transducer hydrophone mounted on one end of a 3-meter-long by 38-mm-diameter aluminum tube, makes a very useful emergency accessory. The instrument, complete with a power supply, switch, and preamplifier, is connected to the shipboard receiver by a length of coaxial cable. This portable unit can be put over the side of the boat (with the transducer end submerged), and rotated by hand when the vessel is hove to. For tracking in bays and estuaries,

this piece of auxiliary equipment has proved to be unusually sensitive, and it may have an application for use as the main receiving transducer from skiffs and craft propelled by outboard motors.

Results of actual tests and trials

The sonic signal frequency of 38 kHz was selected because it is believed to be beyond the frequency range audible to fish, and it was also compatible with available electronic components. Tests conducted at this frequency in laboratory fish pens, even when radiated at more than 10-kW power output, caused no apparent reaction on the marine life.²

In 1963, George A. Bass and Mark Rascovitch, of the American Museum of Natural History, ran a series of experiments with two species of shark and one species of tuna in waters off the Florida east coast and the Bahamas.

Trials on a tiger shark. The sonic capsule was emplaced in the side of a 150-kg tiger shark and the creature was released in 55 meters of water off Jupiter Inlet, Florida. After making an initial straight run of about half a kilometer, the fish followed a crisscross cruising pattern, over an area of several square kilometers, at depths ranging from 27 to 38 meters and at a speed of

Fig. 8. Schematic diagram indicating all electronic components of the shipboard portion of the receiver.

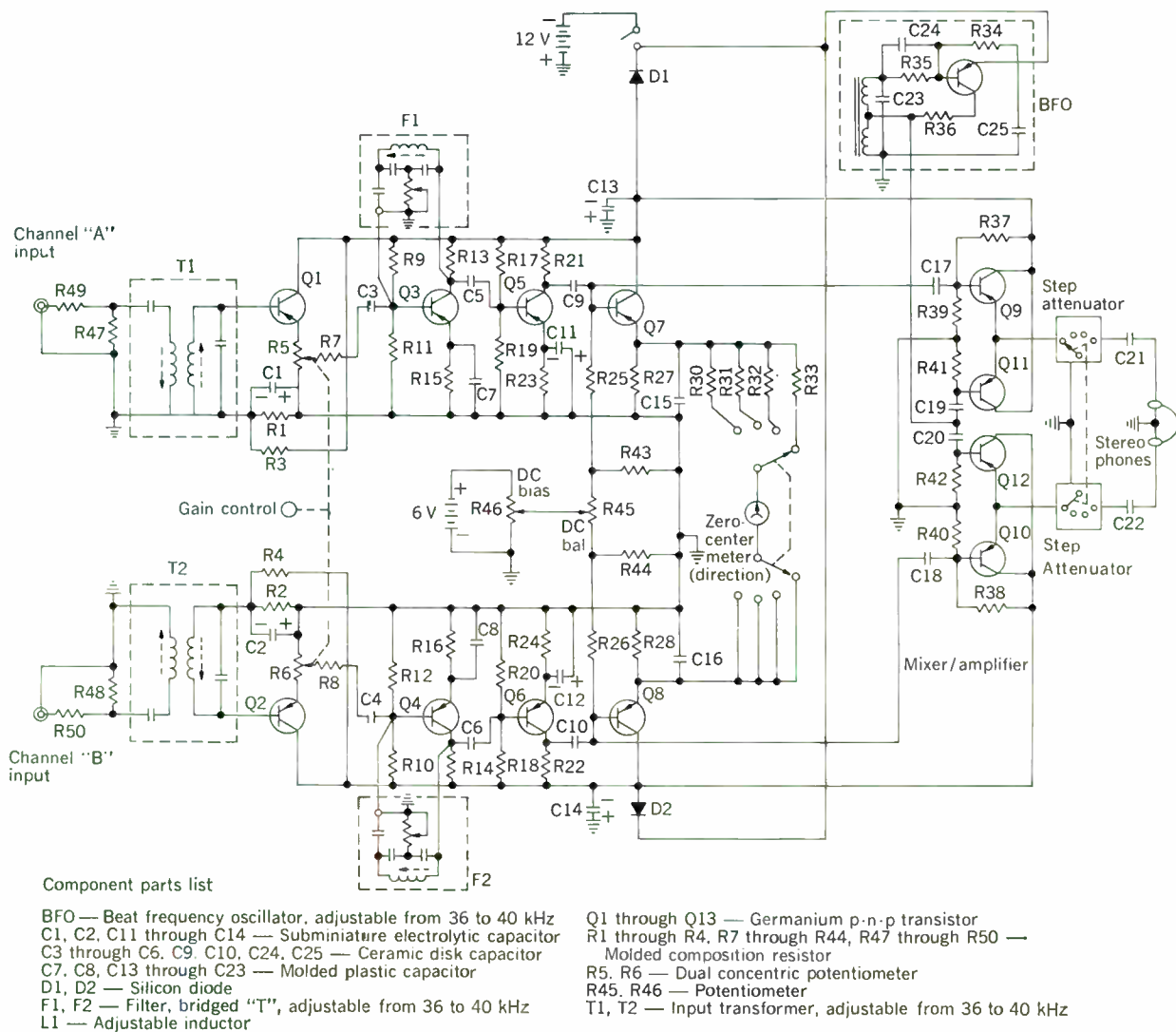



Fig. 9. (Left) A captured tuna is being "fitted" with the special transmitter capsule. (Right) Tuna is shown, just before release, with the capsule attached.

about 6 km/h. The area of activity could have represented the creature's normal habitat. The offshore distance was about six to eight kilometers; the tracking time was four hours.

Trials on a hammerhead shark. On April 16, 1963, a 160-kg (350-pound) hammerhead was released with a transmitter some five kilometers off Palm Beach in waters 100 meters deep. The shark headed in an easterly direction—after some initial meandering—at an average speed of 6 km/h. The tracking vessel maintained sonic contact for two hours; at the end of this time, the boat's position was 15 km east northeast of Palm Beach Inlet.

Trials on 'horse mackerel.' During May 1963, sonic

capsules were affixed (Fig. 9), in individual trials, to large tuna (horse mackerel), each weighing about 200 kg (400 pounds). These experiments were conducted in waters off the Bahama keys.

The first of these fish was released off Gun Cay in 220 meters of water. The tuna immediately sounded to a considerable depth, pursued by a large shark. The tracking boat immediately received a strong signal as the escaping fish swam at high speed in an erratic circular pattern of about one kilometer in diameter. After eluding the shark, the tuna headed in a southwesterly direction at a speed ranging from 5 to 22 km/h. The tracking operation, often at marginal sonic distances, lasted 67 minutes and was

I. Task capabilities of deep-diving submersibles

Commercial	Scientific	Military	General
Assistance in deep-water petroleum production	Bottom exploration and observation of geological formations	Rescue operations	Environmental testing of materials
Exploration and recovery of mineral resources	Oceanographic instrumentation research	Observation platform for viewing weapon firings	Underwater sound research
Bottom surveys and inspection of underwater pipelines	Observation and collection of marine life	Salvage and weapon-recovery operations	Support of ocean engineering projects
Salvage operations	Deep ocean sample collection	Support of underwater instrumentation systems	Underwater power plant support
Underwater photography	Medical research: physiological experimentation support	Minesweeping	Exploitation of food resources
Inspection of sites for sea-bottom installations	Biological, physical, and chemical studies Fish population studies Radioactivity measurements of waste disposal Acoustic measurements Geophysical measurements and surveys	Passive sonar measurements	Underwater inspection and maintenance Marine fouling and corrosion measurements

unexpectedly terminated by the structural failure of the hydrofoil boom, apparently caused by heavy wave action.

In the next experiment, on June 10, a second tuna was released in 30-meter-deep waters five kilometers northwest of Sand Cay. The tracking vessel, situated some 300 meters from the release point, received a strong signal, which was easily followed as the fish headed westerly at a speed of 13 km/h toward the nearby Gulf Stream. After about seven minutes of tracking, the signal terminated abruptly. Evidently, the tuna—transmitter and all—had provided a tasty meal for a very large and voracious predator.

In the final experiment of the series, a tuna was set free about three kilometers west of Little Cat Cay. The subject behaved in a similar manner to the second test fish and soon headed westerly toward the Gulf Stream. Upon reaching deep water, it changed its bearing to southwesterly and maintained a fairly steady speed of 15–20 km/h. At the end of 2¼ hours of tracking, in which the tuna was followed at distances that ranged from 500 to 2500 meters, the estimated offshore distance had increased to 30 km. This highly successful tracking operation could have been continued for a much longer period of time, but the sea state and approaching darkness indicated a precautionary conclusion of the test.

Evaluation and conclusions. The tracking experiments, plus more than two dozen simulated “sled tests” with towed sonic tags, have demonstrated the feasibility and practicality of the basic concept. As is the case in all experimental work, numerous shortcomings in both equipment and techniques are evident, and considerable R & D work must still be done to make the sonic tag method a truly valuable operational tool.

We have reason to believe that the Russians and the Japanese, who are presently competing for world leadership in the whaling industry, may be applying the sonic principle in tracking the “leviathans of the deep.” Meanwhile, interest in the sonic tracking techniques is gathering some momentum in the United States. The Bureau of Commercial Fisheries has a \$900 000 program to include

the installation of a sonar and continuous-transmission FM system aboard its research ship *Townsend Cromwell*. The device will monitor the movements of tuna, sardines, herring, and other schooling marine life at medium ocean depths.

Task capabilities of deep-diving submersibles

Prominent on the list of an extremely wide range of mission assignment capabilities of the heterogeneous family of deep-diving submersibles (these vehicles were described in detail in “Ocean Engineering: Probing the Depths of a Wild Frontier,” *IEEE SPECTRUM*, Oct. 1966, pp. 94–105) is the exploitation of food resources from the sea. In addition to their use in making fish population studies, samples of sea-bottom flora and fauna are routinely collected as a part of nearly every diving mission. These specimens are returned to shore-based laboratories in which exhaustive analyses are made by biological and chemical oceanographers who are seeking new sources of mineral and protein nourishment that may be used either directly as food or indirectly in the fertilization of conventional agricultural crops.

Table I indicates the full scope of submersible applications in four principal categories.

Appraisal, evaluation, and critique

Rapidly evolving events in the worldwide competition for the exploitation of ocean resources have indicated the urgent need for accelerated, far-reaching programs both by the United States government agencies and private industry.

The ‘factory ships.’ Last spring, two large, combination fishing and fish processing ships, flying flags of the U.S.S.R., methodically trawled international waters off the coasts of Oregon and Washington, just outside the 3-mile limit. These extraordinary vessels were equipped with the latest devices for electronic tracking, fish catching, and canning. Huge, flexible suction pipes were used like “sea-going vacuum cleaners,” in conjunction with excellent net equipment to sweep up vast quantities

of bottom-swimming and near-surface-swimming schooling fishes.

While the catch was being taken, an assembly-line process handled the cleaning, salting, marinating, and canning of the various types of fish.

Needless to say, the fishermen of the privately owned fishing fleets based at ports along the Pacific Northwest were furious at this foreign intrusion of their traditional fishing grounds. The small American vessels just could not compete in techniques for catching such huge amounts of fish, and there was further dismay when our fishermen discovered that the waters were virtually "fished out" when the Russians finally moved on.

Although the American fishermen appealed directly to the Federal government to remedy a situation that threatened to be ruinous to the fishing industry of the

Pacific Northwest, very little could be done legislatively except to extend United States territorial waters out to the 12-mile limit.

The bold Russian maneuver of literally fishing in our private backyard dramatically demonstrated the competitive edge enjoyed by an industry that is heavily subsidized by a government. It appears that our ingenuity and resourcefulness will be put to the test if we are to safeguard a historic American commercial enterprise.

Billions for space, millions for oceanography. The Defense, Commerce, and Interior departments of the U.S. Government spent \$138 million for oceanography (see Table II) in 1965. This is about one percent of the total appropriations for the aerospace program during that year. The total expenditure, including that of the National Science Foundation, Atomic Energy Commission, and other government departments, was under \$200 million for fiscal 1965.

Apparently, as indicated in Table II, the estimated overall Federal budget for fiscal 1966 will be only \$178.24 million. By comparison, the overall 1965 budget of American industry (Table III) in oceanographic R & D was about \$453 million.

A number of prominent scientists have convinced Congress to push for a centralized agency to handle oceanographic research. One of the primary objectives of the proposed agency would be to make recommendations for the development and improvement of instruments for oceanographic research.

The basic need, however, is money. Although President Johnson's budget for fiscal 1967 calls for an allocation of almost \$220 million for the national oceanographic program, this would represent only a 20 percent increase over the present budget.

Some scientists feel that oceanographic exploration is of far more potential benefit to mankind than the exploration of space, and that, eventually, appropriations will have to match those of the aerospace programs.

Conclusions of a conference. From the presented papers and discussions at the Second Annual Conference and Exhibit of the Marine Technology Society, held in Washington, D.C., last June, it is apparent that the rate of progress in oceanographic research depends largely on the development and perfection of more reliable and sophisticated electronic instrumentation. Unfortunately, much of the oceanographic instrumentation in use today must be custom-manufactured to meet the exacting standards of reliability and watertight integrity under very high hydrostatic pressure.

Finally, there is the very real hazard that the competitors of the United States, notably Russia and Japan, may be forging ahead of us in some vital aspects of oceanographic research and ocean engineering.

We could be doing more; we should be doing more.

Figure 2 is reproduced through the courtesy of the U.S. Bureau of Commercial Fisheries, Dept. of the Interior, Woods Hole, Mass.

REFERENCES

1. Sette, O. E., "Ocean environment and fish distribution and abundance," Internal Rept., U.S. Bureau of Commercial Fisheries Lab., Stanford, Calif. Presented at the Second Annual Conf. and Exhibit, Marine Technology Society, Washington, D.C., June 27-29, 1966.
2. Bass, G. A., and Rascovich, M., "A device for the sonic tracking of large fishes," *Zoologica*, vol. 50, issue 2, pp. 75-82, Summer 1965.

II. U.S. national oceanographic program budget, fiscal years 1965 and 1966

Government Departments or Agencies	Actual for 1965, millions of dollars	Estimated for 1966, millions of dollars
Defense	98.06	80.48
Commerce	20.10	13.12
Interior	20.17	19.47
National Science Foundation	44.00	43.20
Atomic Energy Commission	5.98	11.59
Health, Education and Welfare	5.25	6.32
Treasury	1.96	2.07
Smithsonian Institution	0.87	1.50
State	0.43	0.49
Total	196.82	178.24

III. Industrial budget for ocean R & D, 1965

Scientific Area	Expenditures, millions of dollars
Instrumentation	110
Underwater sound	85
Ocean surveys	70
Deep-submergence vehicles	45
Mining equipment	30
Power plants	24
Weapons	23
Ocean engineering	14
Hydrofoils	10
Hydrodynamics	10
Project Mohole	9
Man-in-Sea program	6
Waste management	3
Fishing technology	2
Fish products	2
Docks and containers	2
Life support studies, satellite communications, Antarctic programs, etc.	8
Total	453

Insulated sodium conductors— a future trend

Although copper has been the standard electrical conductor since the early 19th century, with relatively recent competition from aluminum, sodium is now stimulating interest in the power industry because of its favorable properties and low cost

*L. E. Humphrey, R. C. Hess, G. I. Addis Union Carbide Corporation
A. E. Ruprecht, P. H. Ware Simplex Wire & Cable Company
E. J. Steeve, J. A. Schneider Commonwealth Edison Company
I. F. Matthyse, E. M. Scoran Burndy Corporation*

Polyethylene-insulated sodium conductors, having economic advantages over conventional conductors, have been developed. The sodium conductors are light in weight and can be manufactured on standard cable-fabricating equipment. The light weight and the usual flexibility of the sodium cable should afford greater ease of installation in direct-buried and overhead power cable applications. Extensive tests indicate that this system is tough and resilient, and can withstand considerable abuse. Sodium's electrical conductivity ranks just below copper and aluminum. A useful service life of 40 years, under normal ambient conditions, is predicted for direct-buried cable.

The concept of using sodium as an electrical conductor is hardly a new one. Back in 1901, a basic Swiss patent was issued for this purpose. In 1905 and 1906, French and American patents, respectively, were issued to Anson G. Betts, who recognized the favorable economics of the metal. His patent specified that "the sodium be enclosed—preferably hermetically—by a sheathing of substantially nonoxidizable reinforcing material."

In 1927, H. H. Dow and R. H. Boundy of the Dow Chemical Company began to experiment with sodium in steel pipes, and in 1930, Dow constructed a line, 10 cm in diameter by 260 meters long, by joining together 6-meter lengths of sodium-filled steel pipe. This uninsulated conductor operated at Dow's plant in Midland, Mich., for about ten years at currents ranging from 500 to 4000 amperes direct current.¹ The results of this experimental work have been published in considerable detail.^{2,3}

M. S. Cantacuzene, in 1941, proposed an insulated sodium conductor in which the sodium was protected by a lead sheath and then insulated with a conventional oil and paper construction. Apparently this system was never put in practice, although a French patent for the method was issued in 1952.

A Dutch electrical engineer, Theodore De Koning, wrote a book⁴ in 1955 that contained a comprehensive and imaginative technical treatise on the properties, manufacture, and use of sodium cables. De Koning proposed an oil-impregnated paper-insulated sodium conductor with a lead or plastic jacket on the outside of the insulation. He also suggested ways of splicing and terminating these paper-insulated cables. But most im-

I. Comparison of various electrical conductors

Metal	(A) Resistivity, microhm- centimeters at 20°C	(B) Specific Gravity at 20°C	A × B Factor	(C) Price,* dollars per kg	A × B × C Factor	Relative Cost for Equivalent Ampere Capacity (ampacity)
Copper	1.72	8.89	15.3	0.80	5.51	6.8
Aluminum	2.83	2.70	7.64	0.54	1.87	2.3
Sodium	4.88	0.972	4.74	0.38	0.81	1.0

* Market prices, March 1966

II. Tensile properties of 15-kV URD sodium cable

Temperature, degrees C	Yield Strength, pounds-force (newtons)	
	Untreated	Irradiated
25	650-725 (2900-3210)	746 (3310)
75	230 (1020)	275 (1220)
90	145 (643)	181 (803)
125	0	60 (256)

portant, perhaps, was his recognition of the advantages to be obtained from the heat of fusion of sodium, compared with copper and aluminum, under short-circuit conditions.

Thus, over the past 65 years, a number of researchers have recognized the favorable economic aspects and physical qualities of sodium. We know that one kilogram of sodium, costing \$0.38, will conduct as much electric current as 3.25 kg of copper, which presently costs about \$2.56. Table I compares sodium with copper and aluminum as an electrical conductor. Although sodium has a resistivity that is 2.8 times as great as that of copper, its specific gravity is only one ninth as much, and its unit cost is one half that of copper. This makes copper 6.8 times more costly for equivalent ampacity; and on a similar basis, aluminum is 2.3 times more costly than sodium.

Introduction to the present development

Sodium is one of our most abundant elements, ranking sixth in occurrence in the earth's crust. It is obtained in elemental form by the electrolytic decomposition of molten sodium chloride in a Downs cell. The process generates chlorine as a coproduct. By comparison, other alkali and alkaline earth metals, such as lithium, potassium, and calcium, are either too costly to obtain or have certain unsatisfactory physical characteristics to make their use as electrical conductors practical and feasible.

While assessing the properties of sodium as an electrical conductor, personnel of the Union Carbide Corporation conceived the idea of fabricating an insulated electrical conductor by extruding a plastic tube and simultaneously filling the tube with molten sodium. It was then determined that polyethylene would most likely provide the optimum overall performance as an electrical insulator, a barrier against air and moisture, and a strength member. It was recognized that special terminations would be required to permit the conductor to be connected to conventional electric equipment.

Here, for the first time, was a simple operational process for manufacturing a flexible insulated conductor that will meet the utilities' need for a low-cost direct-buried cable.

Cable manufacturing process and materials

The cable is made in two steps; in the first, an insulated sodium conductor is produced by the extrusion of a polyethylene tube that is simultaneously filled with liquid sodium (Fig. 1). Upon leaving the extrusion head, the insulated conductor passes through a cooling bath. Then, it is monitored for diameter, insulation thickness, and conductor concentricity by the use of conventional instruments. Because of the light weight and flexibility of the insulated conductor, relatively light duty haul-off and wind-up equipment can be used.

In the second manufacturing step, the insulated conductor is jacketed with a semiconductive shield and drain wires are applied, or other finishing operations are performed, as required, to produce the desired cable construction.

The polyethylene used for the insulation is a standard, low-density power cable insulating compound. When a conductor shield or an insulation shield is specified, a standard, semiconductive carbon black, loaded polyethylene copolymer is satisfactorily employed. Commercial grade (99.95 percent minimum) metallic sodium is generally used.

Laboratory evaluations

Although it was known that the conductor was light in weight and very flexible, it was not known whether the cable was capable of meeting all the technical requirements imposed upon conventional cables. Crude—but effective—terminations were fabricated and sufficient tests were conducted in the Union Carbide laboratory to prove that the sodium was a satisfactory conductor. However, adequate overall testing facilities for this new product were not available at Union Carbide, and, therefore, arrangements were made with the Simplex Wire and Cable Company in Cambridge, Mass., for further evaluation.

Tests of physical properties. For the evaluation program several cables, with voltage ratings up to 15 kV, were tested.

The 15-kV underground residential distribution (URD) cable, shown in Fig. 2, is similar in design—except for the solid sodium conductor—to those that are widely used by the electric utility industry. The conductivity of the sodium is the equivalent of a No. 4 AWG copper conductor, and the concentric copper return wires have a

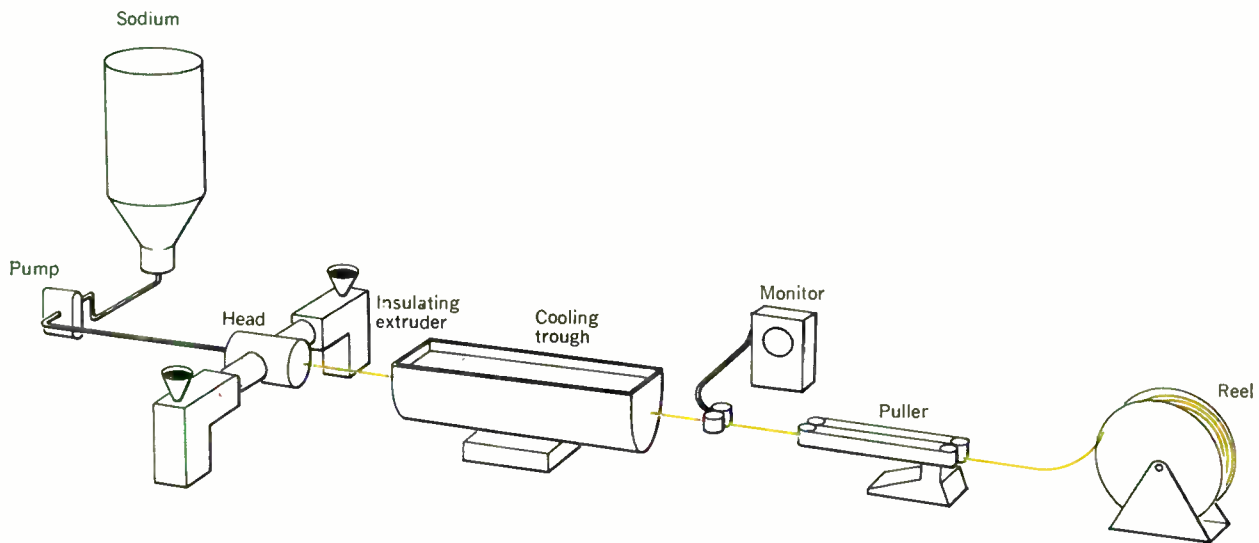

Fig. 1 (above). Schematic diagram of the insulated sodium conductor manufacturing process.

Fig. 2 (right). Cross section of 15-kV URD cable. This typical specimen has a 12.7-mm-diameter sodium conductor core, a 5.6-mm wall of polyethylene insulation, and a 0.76-mm wall of semiconducting polyethylene and copper concentric conductor.

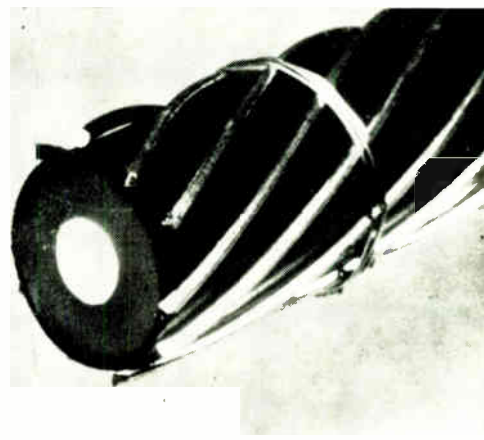
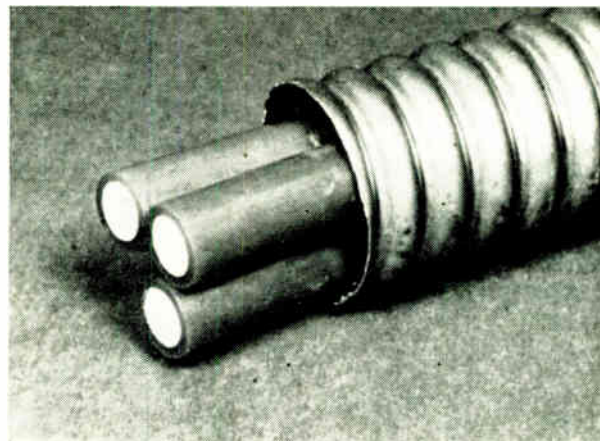

Fig. 3 (lower right). Steel-sheathed 5-kV three-conductor cable, with 12.7-mm-wall polyethylene. The three insulated conductors are laid parallel in a triangular arrangement and are covered by a corrugated welded-steel sheath.



total cross section equivalent to that of No. 4 AWG. In another test cable, a modification of Fig. 2, the concentric return wires are replaced by a continuous-welded, corrugated copper sheath that provides greater mechanical protection in areas where there is a higher probability of physical damage.

The three-conductor cable is a typical 5-kV distribution cable that can be installed either aerially on a messenger or directly buried. It is approximately equivalent to a No. 1 AWG copper conductor.

Two three-conductor test cables, one in a welded corrugated sheath (Fig. 3) and the other a self-supporting aerial type, were made without cabling the individual insulated conductors in helical form. Conventionally stranded, insulated copper or aluminum conductors must be helically cabled together to provide adequate flexibility in the cable, because, without this helical form, their relative stiffness would cause either buckling or permanent deformation when the cables are moderately bent. The elastic nature of the sodium conductor, however, allows it to stretch without permanent deformation when the cable is bent during manufacture, wound on reels, or pulled over sheaves or around bends during installation.

At Simplex, tests were performed to measure the ability of insulated sodium conductors to withstand the me-

chanical rigors of installation and service. The properties tested were: tensile, stretch, flexibility at normal and low temperatures, and thermal expansion characteristics.

Table II shows data from the tensile strength tests that were run on the 1-inch (outside diameter) 15-kV URD cable at several temperatures. Although the strength at normal room temperatures (20°C) is high—in the range of 700 lbf (3100 newtons) tensile load—it falls off sharply when the temperature is elevated to 75°–90°C. Cross-

linking the polyethylene experimentally by irradiation, however, improves the high-temperature tensile strength and adds to the safety factor of the system in the event the cable is operated above its rated temperature.

A useful property of the insulated sodium conductor is its ability to stretch without breaking when overstressed, and subsequently to recover its initial dimensions upon release of the tensile load. As indicated in Table III, when a sample of the conductor was elongated to 125 percent of its original length (100 percent datum) and then released, it recovered to 105 percent in one minute, 102.5 percent in five minutes, and to 100 percent—or complete recovery—at the end of a half hour. Another conductor sample, when severely overstressed to 170 percent, recovered all but 10 percent of its stretch by the end of 24 hours. This physical property of insulated sodium contributes significantly to the ease of handling in the installation of cables. Copper conductors, by comparison, show no recovery when similarly stretched, and they break

III. Mechanical stretch properties of 15-kV URD sodium cable

Elongation, percent of original length*	Recovery Time, minutes	Recovery, percent of original length*
125	1	105
	5	102.5
	30	100
170	2	120
	10	110
	1440 (24 hours)	110

* Original length based on datum of 100

Fig. 4. Plot of short-circuit characteristics for sodium, copper, and aluminum conductors having equal resistance at 25°C. The operating temperature before short circuit is based on 75°C, and the current density is 0.04 ampere per circular mil (78.9 amperes/mm²) of sodium.

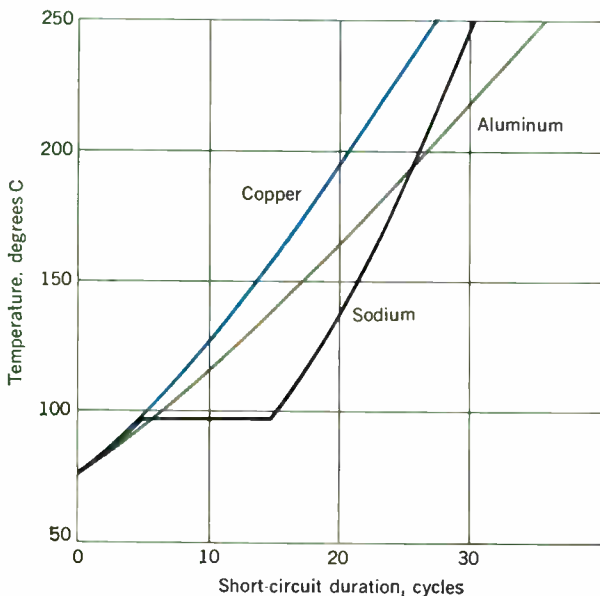

at elongations in the range of 115 to 125 percent of original length.

Other salient physical properties of sodium include:

1. High degree of malleability, with no work-hardening characteristics.
2. Excellent ductility when encased in polyethylene insulation.
3. Substantially greater flexibility than an equivalent copper cable.

Electrical evaluation

Short-circuit characteristics. The heat generated by short-circuit currents in conventional copper or aluminum conductors will quickly raise the temperature to a degree that will damage the insulation. But for sodium conductors, which melt at a temperature lower than that at which polyethylene may sustain damage, the melting action *absorbs* heat—equivalent to its heat of fusion—without raising the temperature. Only when the sodium is completely melted will the heat generated by the short-circuit current again cause a temperature rise. Because of this heat-of-fusion effect, the time-temperature characteristics of sodium conductors are somewhat different from those of conventional conductors (Fig. 4) within the probable operating range of power distribution cables. Figure 5 indicates that a sodium conductor will have a greater short-circuit ampacity than a copper or an aluminum conductor with the same resistance at 25°C.

Corona level. One measure of the quality of a cable, which has a bearing on its estimated life under voltage stress, is the corona extinction level (the applied voltage at which any internal ionization of the cable structure

Fig. 5. Graph of allowable short-circuit currents for polyethylene-insulated conductors.

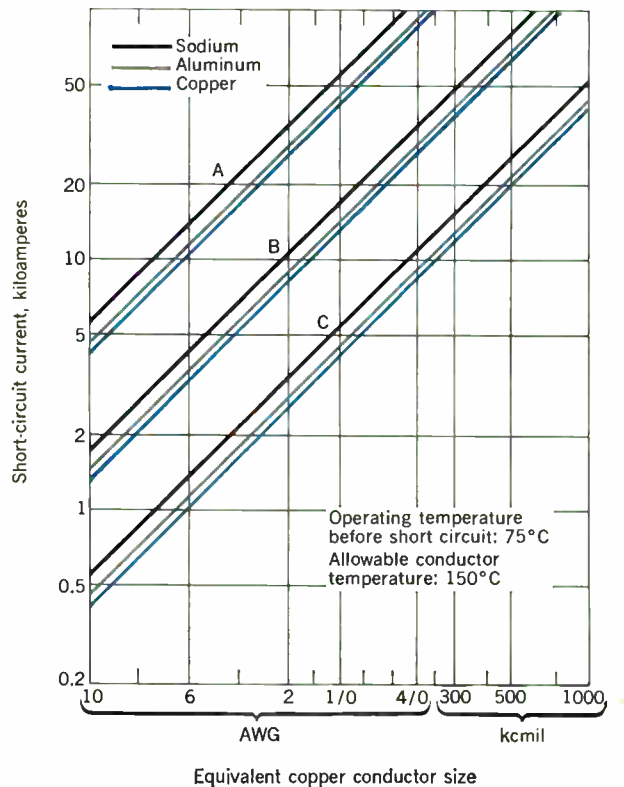

will cease to exist as the voltage is decreased). Since ionization is one of the principal causes of insulation deterioration—and eventual failure of the cable—it is important that it does not exist at operating voltages. Further, the corona extinction level should remain high even after the cable has been subjected to physical abuse.

A 15-kV URD sodium conductor cable about 12 meters long was wound around a mandrel whose radius was less than seven times the cable diameter; then the cable was straightened and bent in the opposite direction. This procedure

was repeated so that the cable received two bendings in each direction, 180 degrees apart. The corona extinction level, both before and after this treatment, was at 26 kV.

These results, and those of other corona-level tests, indicate that conductor shielding may not be required on polyethylene-insulated sodium conductors—at least up to a 15-kV rating—even under severe bending conditions. The smooth surface of the solid sodium conductor and the voidfree interface between conductor and insulation provides this freedom from ionization.

IV. Alternating-current breakdown tests of polyethylene-insulated sodium conductor

Conductor Diameter, mm	Insulation Wall, mm	Breakdown Voltage, kV	Average Stress, kV/mm
(5-minute steps)			
12.7	5.6	164	29.3
12.7	5.6	157	28.1
12.7	5.6	131	23.4
8.5	5.6	157	28.1
8.5	5.6	109	19.5
8.5	5.6	157	28.1
8.5	5.6	157	28.1
8.5	5.6	157	28.1
13.6	5.6	157	28.1
16.5	4.45	87	19.5
(24-hour steps)			
8.5	5.6	109	19.5

V. Impulse tests of polyethylene-insulated sodium conductor

Conductor Diameter, mm	Insulation Wall, mm	Impulse Strength, kV/mm
8.5	5.6	85.0
8.5	5.6	92.5
16.5	4.45	91.4
13.6	5.6	85.0
8.5	5.6	110.0
12.7	5.6	78.7

VI. Load-cycle tests of polyethylene-insulated sodium conductor

Time, days	Conductor Temperature, degrees C	Voltage to Ground, kV	Power Factor,* percent	Corona Level, kV
Initial	—	—	0.019	13‡
3	75	17.4	0.019	22§
10	75	17.4	0.019	22§
21	75	17.4	0.019	22§
22	85	26.0	0.019	22§
31	85	26.0	0.019	22§
42	85	26.0	0.019	22§
43†	—	—	0.019	31‡

* Measured at stresses of 20, 60, and 100 volts/mil (787, 2360, and 3940 volts/mm)

† Tests were made 30 hours after completion of 42-day test

‡ Extinction voltage

§ No corona at this voltage

AC step-dielectric strength, impulse, and load-cycle tests. Step-rise 60-Hz ac voltage breakdown tests were conducted on several samples of 15-kV URD polyethylene-insulated cable. Starting at 44 kV to ground, the voltage was raised in steps of approximately 20 percent of the immediately preceding voltage until failure occurred. The voltage was kept constant for five minutes at each step in one series of tests; in another series, the voltage was kept constant at each step for 24 hours. The detailed results are shown in Table IV.

It may be interesting to note the relative consistency of the dielectric strength of the tested specimens, averaging 20 to 25 percent higher than that of conventional copper or aluminum conductor cables with strand shielding and the identical insulating formulation.

Impulse tests were made with a standard $1\frac{1}{2} \times 40$ -microsecond wave. Testing was started at 95 kV and the voltage was increased in steps of approximately 20 kV. The cable was subjected to three negative impulses at each step. The results, shown in Table V, compare favorably with those of conventional cable constructions.

The ultimate laboratory evaluation for a new power cable construction is the load-cycle test that is run by applying current for eight consecutive hours in every 24-hour period, and a continuous 60-Hz ac voltage between conductor and shield of 15-kV URD cable.

For the first 21 days, 17.4 kV (twice the rated voltage to ground) was applied, with sufficient current to produce a conductor temperature of 75°C. During the next 21 days, the current was increased to produce a conductor temperature of approximately 85°C, and the voltage was increased to 26 kV, three times the operating voltage. Daily power factor and corona level measurements were made. The results of one typical test series are recorded in Table VI. The sample had not failed by the end of the 42-day test period and no appreciable change was noted either in the power factor or corona level.

The initial low corona level value (13 kV) indicated in the table was caused by a faulty stress-cone termination, but this condition was corrected before the other readings were taken. The limit of the set available at the test site was 22 kV so that the values reported as 22 kV were undoubtedly higher, as indicated by the 31-kV value determined at the conclusion of the tests.

A word of caution

Metallic sodium must be handled with reasonable caution because it has a high rate of chemical reactivity with water. Although sodium is less active than potassium, it reacts rapidly with water at room temperature to produce sodium hydroxide (NaOH) and hydrogen. Sufficient heat is liberated by the reaction to melt the sodium. If a large surface area of sodium is exposed to water, the reaction becomes explosively rapid, but a small surface

exposure will trigger only a relatively mild reaction. Polyethylene serves as an effective barrier to air and water while simultaneously providing the mechanical strength and electrical insulation required for many types of cable. Thus, unless the insulation is breached, the sodium is completely protected from chemical reaction.

Field evaluations: Chicago

The next step in the evaluation of sodium conductor cables was to test them under conditions more nearly representative of actual service. For this purpose, URD cables were installed by the Commonwealth Edison Company on its Northwest Generating Station property in Chicago. Here, a plywood terminal shelter housed the transformers, buses, instrumentation, and cable terminals. Cable poles were also erected to simulate actual field conditions.

Four 7200-volt (to ground) loop circuits, each about 120 meters long, were installed at the test site; see Fig. 6(A). Three of the circuits each included 107 meters of the 15-kV sodium conductor cable, and 15-meter leads of standard 15-kV copper conductor cable were used on all four circuits from the terminal shelter to the cable poles. The entire 120-meter length of the fourth circuit (loop 1), however, was composed of conventional 15-kV copper conductor cable. In addition, six lengths of 600-volt secondary sodium conductor cables, each 34 meters long, were terminated in the shelter and in a standard service pedestal.

Two 15-meter lengths of 15-kV cable (one with a sodium conductor and the other with conventional copper), with thermocouples, Fig. 6(A), mounted on the

outer shields and under the insulation on the conductor, were used to correlate sheath and conductor temperatures on the four 120-meter circuits.

Current for the load-cycle tests, Fig. 6(B), was supplied from a 120/240-volt source at a nearby substation. Cables were loaded by means of 120/240-volt variable-voltage transformers, feeding 37.5-kVA, 7200/2400/240-volt transformers. The 240-volt terminals were insulated for 7.2 kV to ground.

Test cables and their installation. All of the 15-kV cables used in the field tests were concentric-type polyethylene-insulated, with ten No. 14 solid-tinned copper wires on the outside of the cable. The diameter of the sodium conductor used for the load-cycle tests, and the first short-circuit and fault tests, was 0.500 inch (12.7 mm). Cable insulation was 5.6 mm of high-molecular-weight polyethylene, followed by an extruded layer of 0.76-mm semiconductive polyethylene. Later, a sodium conductor (equivalent to a No. 4 copper conductor) having a diameter of 0.335 inch (8.5 mm), with the same insulation and shield dimensions, was used in some of the fault testing.

Trenches for the test cables were 20 cm wide by 76 cm deep. The ground conditions encountered during the installation consisted of a mixture of dry loam, some cinders, and an appreciable amount of stone and rubble at the far end of the trenching. Distilled water extracts of earth samples indicated pH values of 8.1–8.4 (slight alkalinity).

Crew members installing the cable were not aware of the nature of the conductor and, therefore, no special precautions were taken in its handling. After the installation, the cables were proof-tested to ensure that:

1. The circuit was complete.

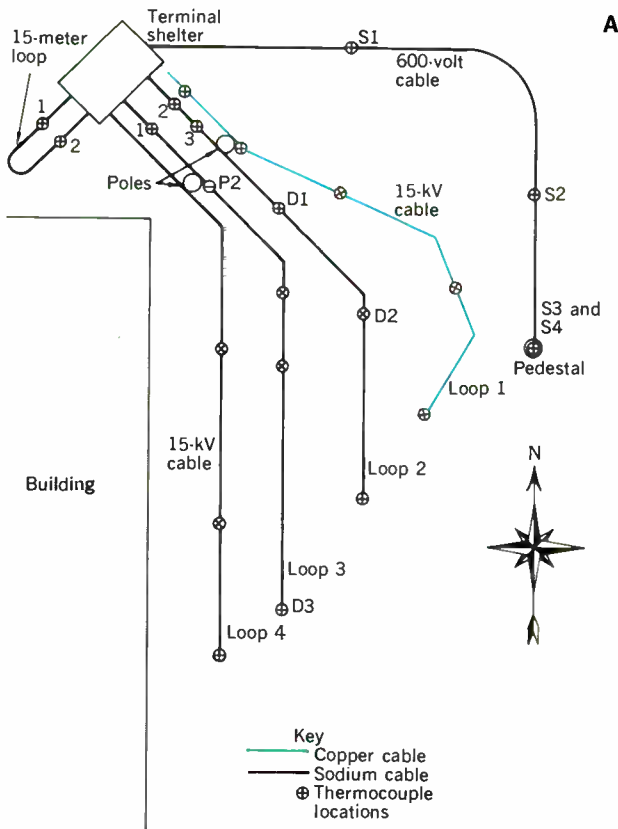
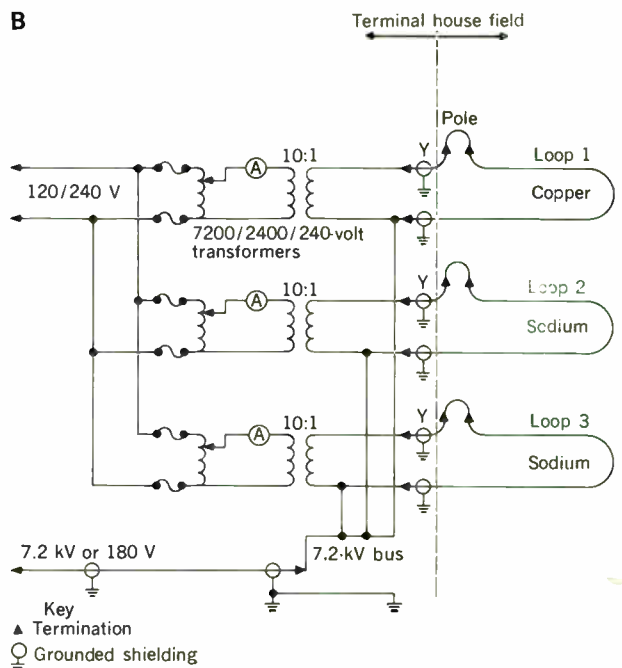

Fig. 6. A—Layout of Commonwealth Edison's test cables, showing thermocouple locations. B—Schematic diagram of the test cable circuits shown in A.



VII. Condensed summary of load data on 15-kV, 12.7-mm-diameter sodium conductor cable

Date of Test	Temperatures			Cable Loop No. 2			Cable Loop No. 3		
	Air, de- grees C	Earth, degrees C	Load, amperes	Jacket Temperatures, degrees C			Jacket Temperatures, degrees C		
				D1*	D2*	No. 2*	D3*	No. 1*	P2*
12-1-64	-4.4	9.6	50	11.3	11.2		12.1	6.3	
12-3-64	1.1	9.4	75	12.0	13.5		13.6	8.5	
12-7-64	-2.8	8.5	150	27.3	29.8		25.5	22.5	
12-10-64	2.8	7.5	190	37.0	40.6		35.8	29.2	
12-11-64	5.6	6.8	195	39.9	43.6†		34.5	33.0	
1-5-65	4.4	5.5	200	18.7	21.5	12.0	19.1	16.0	21.4
1-8-65	15.6	4.8	200	21.0	23.0	21.0	20.9	21.4	29.4
1-21-65	0	4.8	240	33.0	38.0	38.5	33.7	39.7	29.5

* Thermocouple station numbers
† Maximum sheath temperature. This corresponds to a conductor temperature of 51.8°C at a loading of 195 amperes.

- Design conductivity had been maintained.
- There was neither a serious defect in the system nor had any gross damage been done in handling.

Field load-cycle tests. Field loading and cycling conditions were simulated by alternately circulating current through the test loop for a period of time and then allowing the cable to cool for another time period with the current off. A potential of 7.2 kV was impressed continuously between the conductor and ground during the test.

Different current loadings were applied for different numbers of cycles and for various cycle periods. Loading was increased stepwise from 50 to 250 amperes. Jacket temperatures were measured at the end of both the current-on and current-off parts of the cycle. The recorded load cycle data are given in Table VII.

Correlation between jacket temperatures and conductor temperatures was approximated by circulating current without voltage through a separate 15-meter loop of 15-kV sodium cable that was buried at a depth of 76 cm. This permitted two sets of thermocouples to be used to measure conductor and jacket temperatures.

Short-circuit and fault tests. Fault conditions were simulated by short-circuiting one end of test loop 2 to ground and then subjecting the cable to 7.2 kV between conductor and ground. An oil circuit recloser was used in series with fuses of various sizes to provide a group of fault loadings. The short-circuit characteristics were as follows:

Maximum Current, amperes	Duration, cycles	Loop Resistance, ohms
2400	2	0.0533
3200	3	0.0532
2700	4	0.0531

Resistance measurements served to indicate that continuity of the conductor was maintained after the high momentary overload.

The majority of faults on Commonwealth Edison's residential underground distribution system are caused either by dig-ins during contractors' excavations in connection with sewer and water lines or by home owners digging post holes. To simulate this type of fault, deliberate damage was inflicted upon 6-meter lengths of the sodium

conductor cable placed on the surface of the ground.

Faulting was accomplished by driving a needle through the insulation by means of a .22-caliber blank cartridge that was fired by a specially designed mechanism. Three fault tests were made in air on the 12.7-mm-diameter sodium conductor cable. Trials 4, 5, and 6 were conducted by using a 15-kV cable with a sodium conductor diameter of 8.5 mm, equivalent in ampacity to a No. 4 AWG copper conductor.

The program for the last three tests included a fault in air (trial 4); a fault in a 15-cm-deep trench, with about 10 cm of mud cover on the cable (trial 5); and a fault in the same trench with a 10-cm cover of water (trial 6). Significant data, obtained from an oscillograph, on all six tests are shown in Table VIII.

The physical effects of the testing on the cable were as follows:

Trial 1. Most of the concentric wires were burned off by the fault. Approximately 9.5 to 12.7 mm of conductor melted or eroded on either side of the fault, and pockets formed further along the conductor as the fault swept out the sodium.

Trial 2. None of the concentric wires were severed, and very little conductor material was either melted or eroded by the relatively high current.

Trial 3. Only a few concentric wires were severed; however, the heat generated by the fault current softened the polyethylene in the area of the fault, and the cable became severely distorted at the fault point.

Trial 4. Although the cable was almost severed by the heat of the fault, there was no subsequent reaction of the sodium after the recloser locked out. The inside surface of the insulation appeared to be swept clean of conductor material to a definite point.

Trial 5. The fault hurled mud over an area of about 6 meters in radius. No reaction was noted to indicate that mud had entered the cable opening created by the fault (see Fig. 7).

Trial 6. The fault hurled water over an area similar to that of trial 5. Water entered the fault hole and the secondary chemical reaction continued for about six minutes. Small particles of sodium occasionally came to the surface of the water where they burst into momentary flame. Approximately 7.5 cm of material on each side of the fault reacted with the water.

Fault-detection tests on the 15-kV sodium cable laid

VIII. Fault data on 15-kV sodium conductor cable

Conductor Diameter, mm	Trial No.	Current,* amperes	Duration, cycles	Recloser Spacing, seconds
12.7	1 (air)	2300	4	3
		†	4‡	
12.7	2 (air)	5000	2	Recloser locked out
		†	6‡	
12.7	3 (air)	6000	2	3½
		3500	2	
		5000	4	
		3060	1½	
8.5	4 (air)	3100	2½	2
		3200	8	
		3060	1½	
8.5	5 (mud)	3400	1½	2
		2825	7¼	
		3120	1½	
8.5	6 (water)	3675	1½	2
		3000	8¼	

* Largest rms current of duration
† Unable to determine magnitude from recorder
‡ Estimated values

on top of the ground indicated that a fault-locating procedure would probably be identical to that used for aluminum conductor cables. It is Commonwealth Edison's experience, without exception, that faults on aluminum primary cables result in open conductors. Thus it is the company's practice on these types of faults first to obtain an approximate location by means of either a capacitor bridge or a radar fault detector.

Tests on 600-volt sodium cable

The conductor equivalents for Commonwealth Edison's 600-volt secondary cable URD system require at least ten times the quantity of conductor material that is used for the 15-kV primary cables.

This cable was installed in a 10-cm-wide by 58-cm-deep test trench, as shown in Fig. 6(A). In the load-cycle tests, current ranging from 200 to 280 amperes is applied in cycles of five days on and two days off. Since these tests are still in progress, complete data and results are not yet available.

To simulate installation damage, a 180-degree slit was made completely through the insulation of one of the cables. Voltage was not applied, however, and the conductor remained buried in the moist earth in order to show how a sodium cable would react before connection to a meter box.

Continuity and resistance-to-ground measurements were taken twice weekly during a five-week period. Resistance at first increased from 100 kilohms to 3 megohms before it slowly decreased to a low of 30 kilohms at the time of uncovering. Loop resistance measurements never varied and always indicated a continuous conductor.

When the cable was uncovered after five weeks, there was a surprisingly small amount of damage. Although a crusty, white sodium salt was visible around the cut, slices of the cable at 3.2 mm to each side of the damaged point showed no deterioration or decrease in the size of the conductor cross section.

Water immersion tests. To test the reaction of an exposed sodium conductor in water, a large "vee" cut was made in one of the 600-volt cables. A narrow trench

was left open to expose the cut and sheet polyethylene was placed under the cable to act as a water reservoir. Clean tap water was then poured into the trench to cover the cable to a depth of 15 cm.

The immediate chemical reaction produced a bubbling at the surface of the water. After several seconds, a few small pieces of metallic sodium floated to the surface. This was followed by an intermittent series of sharp explosions—much like the detonation of a string of firecrackers—and white smoke. Water and small pieces of sodium were thrown from the trench in all directions. The reaction was readily stopped, however, by dumping two shovelfuls of dirt into the trench.

Since the degree of chemical reaction is a function of the conductor area exposed, additional precautions may be required when larger size conductors are investigated.

Other field tests in progress

A 150-meter length of cable (combined aerial and underground), consisting of three sodium conductors, each 0.536 inch (13.6 mm) in diameter, insulated with a 5.6-mm wall of high-molecular-weight polyethylene, and shielded by 0.76 mm of semiconducting polyethylene, has been installed by the Boston Edison Company as part of a 13.8-kV commercial and residential distribution circuit. The utility plans to observe the performance of this cable under actual service conditions for one year to accumulate operational data for varying climatic conditions.

An aerial cable, made up of three sodium conductors, each 0.650 inch (16.5 mm) in diameter, insulated by a 4.45-mm wall of high-molecular-weight polyethylene and with 0.76 mm of semiconducting polyethylene as insulation shield, has been installed as part of a 12-kV residential loop circuit by the Ohio Power Company near Canton. Results of the evaluation under service conditions will be reported after a sufficient performance record is accumulated.

Connector design and installation technique

Because of the chemically active nature of sodium and its physical properties (notably softness), this conductor

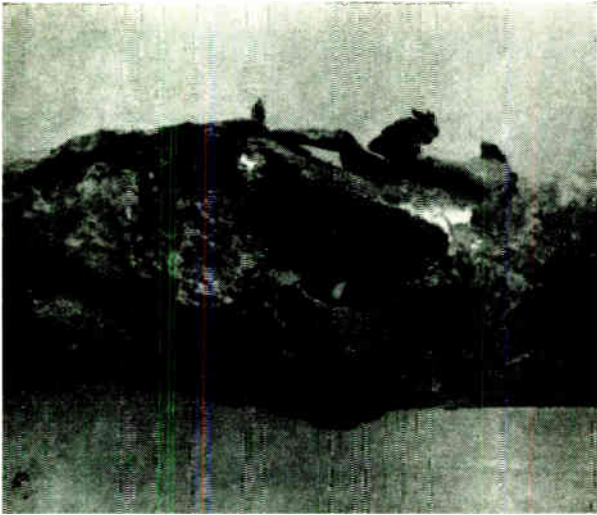

Fig. 7. Faulted 8.5-mm-diameter 15-kV sodium cable (trial 5), showing considerable structural damage.

Fig. 8. Cutaway view showing complete enclosure of polyethylene insulation prior to penetration of sodium core.

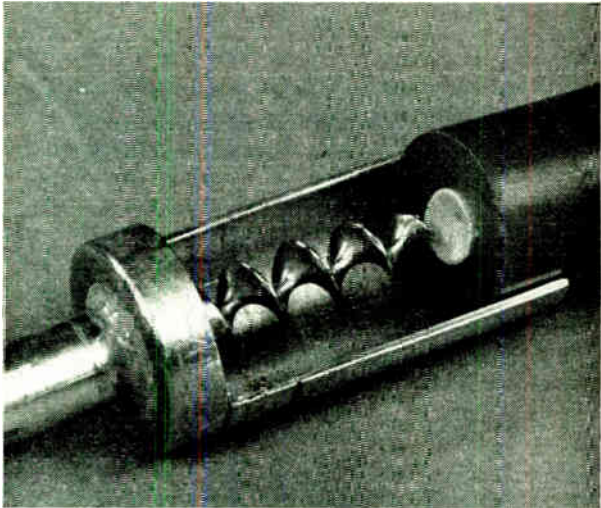
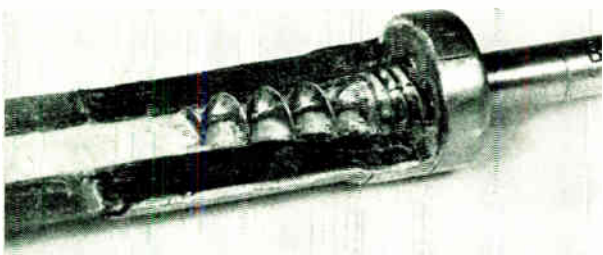

Fig. 9. Cutaway sectional view showing the completed connector installation.



cannot be handled conventionally like copper and aluminum in making electrical connections. Therefore, the integrity of the connection to an insulated sodium conductor must depend on the mechanical properties of its insulating sheath and the low-resistance contact that must be maintained with virtually no contact pressure.

Six objectives. The design parameters have imposed the following six objectives to the successful development of connectors:

1. Minimum exposure of sodium during installation.
2. Completely sealed joints.
3. Secure mechanical grip on the conductor insulation.
4. Permanent low-resistance contact to the sodium core.
5. A rapid and simple installation technique.
6. Economical connector design.

The principal difficulty in penetrating the sodium core—despite the relative softness of the metal—was found to be the force required to effect the penetration. Fortunately, however, a very simple “corkscrew” design for a contact member was conceived in the solution of this problem. The outside diameter of the screw-shaped contact member permits it to grip the inside of the polyethylene insulation (Fig. 8), while its thread contour (Fig. 9) is designed to displace a minimum amount of the sodium conductor. Electrical contact is made across the large contact area presented by the specially treated screw surface.

Field practice. Since the conductor has to be cut to the desired length in the field, the exposure of the sodium core at the cut end—prior to fitting the connector—is the only exposure that is tolerated during the installation process. Although means were considered to eliminate the condition, this minimal exposure is found to be completely safe.

The insulated conductor is very easily cut with pruning shears and may be immediately inserted into the connector. Any negligible sodium residue remaining on the shear blades may easily be removed by wiping with a damp paper towel.

In the next field operation, the connector is twisted onto the conductor in the same manner as twisting a corkscrew into a cork. When an abrupt increase in torsional effort is felt, the installer knows he has completed the operation.

Finally, to seal the joint and to provide a secure grip to the insulation, the outer cylindrical sleeve is compressed by using a standard compression tool that is equipped with a rounding die.

As the simple construction, installation techniques, and economic cost studies indicate, the six objectives, or design criteria, have been successfully met.

This article is based on five papers presented at the IEEE Summer Power Meeting, New Orleans, La., July 10–15, 1966.

REFERENCES

1. Mildner, R. C., Dow Chemical Co., Private communication.
2. Boundy, R. H., “Sodium in pipe successful as electrical conductor,” *Elec. World*, vol. 100, no. 26, p. 852, Dec. 24, 1932.
3. Boundy, R. H., “A 4000-ampere sodium conductor,” *Trans. Electrochemical Soc.*, pp. 151–160, Sept. 1932.
4. De Koning, T., *Cooling Electrical Machines and Cables*. The Hague, Netherlands: Groothertoginne, 1955, pp. 202–232.

Communications — concept and reality

With the introduction of sophisticated techniques such as switching, and encoding, and computer memories, “communication” has gone far beyond its original function, the simple transmission of a message, to complex systems requiring many specialists from many disciplines—and so we have produced the “systems engineer.” Since education can also be considered a form of communication, it is suggested that it utilize these communications concepts to help solve two of the most difficult problems it faces today: the organization and integration of our ever-increasing, increasingly segmented, store of knowledge.

For many years I have presented discussions of various specific devices, circuits, and systems. Now, as an academician, and perhaps even worse, as an administrator, I am no longer required to know anything specific. Thus I shall proceed in a somewhat philosophical vein.

To establish the appropriate academic atmosphere, we should first define our terms, especially “communication.” Those who have been interested in the field as long as I have, since the early 1930s, may have noticed that the term and the subject to which it refers have somehow escaped our grasp. Life used to be simple; we talked about the telegraph, or telephone, or radio—or, in an even less complex era, perhaps smoke signals or carrier pigeons. Comparatively involved concepts, such as pulse code modulation and thresholds and pattern recognition, hadn’t been invented. We weren’t even bothered by transistors and memory; logic may have been important to Aristotle and George Boole but it didn’t matter to us. The good old days were idyllic and uncomplicated. We did not have to spend a great deal of time at technical meetings as we do now just to keep up with the vocabulary, let alone the hardware.

Now the field that we describe as “communication” has become a monster—a fascinating, useful, challenging, profitable monster, but nevertheless a monster. Most of us can agree with that statement even if we can’t agree as to just how many heads, eyes, arms, and feet the monster has. Switching entered the arena some time ago, and then Shannon introduced encoding. With switching and encoding, memory had to come in, and soon after we had a world filled with computers. Finally, information storage and information retrieval were added to information transmission.

The systems engineer

By 1960 communication had broadened to cover anything that one could do electronically to information, but it had broadened even beyond that in two ways. Members of the newspaper and advertising and television

Communication has progressed a long way from the day of the smoke signal; it has evolved into a complex process involving many fields and disciplines. The most important problem now becomes one of achieving intellectual integration

W. Deming Lewis Lehigh University

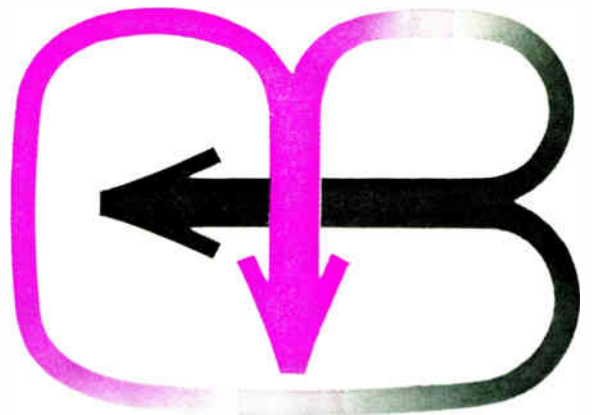

industries had begun to describe their work as communication; then we discovered the word “system,” and suddenly by some mysterious process many of us became systems engineers.

Both of these expansions had real impact. Madison Avenue, the newspapers, and television had discovered a real truth that had not been formalized or even well articulated by the communication theoreticians—that communication is something that happens between one mind and another. Unless some fact or concept or idea or argument or picture, or perhaps feeling, in one mind is transferred to some other mind, communication has not really occurred. If we define this process of transfer as communication, then communication includes not only the telephone, telegraph, radio, and television, but also letters and books and newspapers. It also includes the process of education.

Many may not like this broadening of the definition of communication. It certainly won’t make life any easier, especially for those who want to wrap up their understanding of their disciplines into a set of nice tidy packages, but it has some interesting consequences. Before considering these, let us think a bit about the word, and the concept of, “system.”

In the simpler days there were electrical engineers and mechanical engineers and various other special kinds of engineers, and within these specialties were sub-specialties—power engineers, telephone engineers, radio engineers, computer engineers. Most of us understood what was meant when we used these terms. At the universities, we knew what to teach to prepare our students for these specialized areas. Then the so-called “systems” engineer arrived on the scene.

What is a systems engineer? How is one trained to become a systems engineer? Can a systems engineer exist in some general sense, or must he be some special type of engineer first and then become a systems engineer in a system of that specialty? If this last is true, how do systems involving many specialties, such as complex military or space systems, ever get engineered when no one man could possibly be an engineer in all the specialties they involve?

I have thought about these questions a great deal, and have asked others about them. For more than five years I headed groups with the word “systems” in their titles and I still do not know the answers—nor have I met anyone else who has convinced me that he does either.

In spite of all this, we have successfully built many systems: railroad, radio, and weapons systems, the Surveyor system, the Bell System. Thus, looking at the subject objectively, whether we understand it or not we must admit that effective systems engineering is going on.

Communication's varied roles

If we take the two steps beyond the ordinary, everyday definition of communications—if we broaden the definition to include any process that transfers something from mind to mind, and also to encompass complex systems and the possibility of designing better ones even though we may not know exactly how to go about it—we can come up with some fascinating speculations. Some of these are already on record. For example, just consider a few of the titles in the section on “Communication and Electronics, 2012 A.D.” of the 50th Anniversary Issue of the *PROCEEDINGS OF THE IRE*: “Extending Man's Intellect by Electronics,” Simon Ramo; “Communication as an Alternative to Travel,” J. R. Pierce; “Controlling Man's Environment,” Harold A. Wheeler; “Public Functions and Standing of the Engineer,” C. F. Horne; “Electrons and Elections,” Sir Robert Watson-Watt; “Electronic Nirvana,” Daniel E. Noble; “Electronics and Evolution,” Jerome B. Wiesner. They may sound like science fiction, but if so, science fiction by scientists of such prestige should be taken seriously.

The time scale of these predictions is 50 years, but

at the rate that things are happening today 50 years is a long time. Admittedly, if one's focus is primarily on next year's balance sheet, these writers were overly visionary, but if we are interested in the longer view then Wiesner's statement is most appropriate: “It is probably impossible to be visionary enough to match reality.”

In one of the articles listed, John Pierce suggests communication as a substitute for travel. This has certainly come to pass. Communication in the form of the telephone is being widely used as a substitute for social travel—as anyone with a teenager in the house can assure you; and in the business world more and more transactions are being completed via telephone and telegraph. Electrical communication is also used extensively as a substitute for travel to entertainment and sporting events, as the moviemakers and the manufacturers of television sets can attest.

If we accept the broad definition of communication—that is, the process of transferring information from mind to mind—and include not only the facts transferred but also that part of the transfer that gradually changes the receiving mind, then education is clearly a form of communication. To progress a step further, educators might receive suggestions and guides to thought by considering their problems in terms of communication concepts and models. Perhaps it would be too much to hope that this thinking could become highly quantitative, but some useful insight might be achieved by qualitative thinking about education derived from the field of communication.

This thinking in terms of communication concepts would be, in a sense, an extension of one kind of thinking that already has achieved some effective results; that is, the exploitation and application of ways in which the electrical techniques and tools of communication can be applied with advantage to education. Much has been published recently about closed-circuit television into the classroom, taped lectures, language laboratories, and teaching machines. The applications of these tools are increasing rapidly and new tools are constantly being generated and suggested. However, the application I am now advocating is of the concepts and ideas of communication rather than the hardware.

Communications concepts as a tool

It seems to me that the ideas and concepts of communications can help us to deal with two of the most difficult problems facing education today. One of these problems is caused by the increase in the amount of knowledge—the so-called “information explosion.” The other is caused by the complexity of many of the practical activities of modern life as conducted by big government and

big business. These complex activities often require the simultaneous attentions of many specialists from different disciplines and fields. They have resulted in another explosion, which might be called the “explosion of relevance”; it is just as significant as the explosion of knowledge but is considerably less recognized or discussed.

Once, it is said, all of learning could be within the province of one man. The last man for whom this was true, it is also said, was Leonardo da Vinci, although Benjamin Franklin certainly made a good attempt at it, as did Thomas Jefferson. Beginning in the 19th century, however, and continuing with increasing intensity ever since, we have had a proliferation of new knowledge resulting from research and from the increasing complexity of man’s affairs.

In his influential book *Two Cultures*, C. P. Snow focused attention upon the difficulty of communication between scientists and nonscientists; this breach has continued to widen and to frustrate intellectuals. I think that Snow had a good point but that he was too limited in his expression of it. The problem is that we have frozen our cultures, erected false barriers, and developed subcultures and subsubcultures. Nuclear physicists cannot talk with solid-state physicists. A student of management science has difficulty communicating with a student in the related field of operations research, although neither discipline existed a generation ago. And in the medical field we have so many specialties and specialties within specialties that someone recently observed that the otolaryngologist may soon specialize in the right or left nostril, or the right or left ear.

Norman Cousins, writing in *The Saturday Review*, observed that for C. P. Snow the main problem of the two cultures is concerned with what is communicated. The artists and the scientists are conversing, but not about the most compelling subjects—and this is the real failure of the two cultures. Creative brainpower and advanced skills are not being directed to meeting the greatest need of humanity. The common and tragic failure of both the arts and the sciences is that they have given most of their energy to immediates and intermediates and very little to ultimates. They have advanced our comfort without necessarily safeguarding our destiny. Each has served its own tradition, Mr. Cousins says, without expanding to encompass the essentially new problem of a world that has become one before it has become whole.

What Mr. Cousins seems to be saying is that we must frown upon intellectual provincialism and encourage an understanding of at least the philosophical bases of other fields; each special field must learn to communicate *to* and learn to understand communications *from* other fields. Only by looking at nature from the same point of view can we advance together. Our impetus should be to make one culture out of many, to allow all of our special cultures and subcultures to work together to form an integrated cultural system.

In the same vein, the philosopher, Alfred North Whitehead, has said: “The discoveries of the 19th century were in the direction of professionalism so that we are left with no expansion of wisdom and with greater need of it.” I believe that our most pressing educational problems arise because we are teaching a segmented culture. Academic departments are all too often ivory towers of professionalism; they think of freedom from contact with other disciplines as one of the academic freedoms. No

wonder many students are confused, and some are repelled, by what they find at the university. The faculty talks to them about many provinces and islands of learning in many special vocabularies. Few try to provide them with even a rough map of the world of knowledge, or with a lingua franca that will be adequate for conversation with any specialist. No one can do so because such things do not exist.

The danger of parochialism

It is the very nature of an academic community to protect its islands of scholarship. Academic freedom is a long-standing tradition, one that is necessary to protect the faculty from the dangers of intrusion and interference that could jeopardize their efforts as scholars and pedagogues. Pride in professional accomplishment is obviously desirable. However, today, when so much of our learning must be interrelated if it is to be useful, intellectual parochialism produces a major strain on the educational process. Our troubles arise not only from the vast amount of knowledge that is available to be taught but also from the fact that it exists in such a large number of separate and noncommunicating packages.

The communicators have done much to eliminate geographical parochialism. Their systems have made communication between the geographical islands of the world a fact of daily life and a resource of daily commerce. As a result, we are rapidly becoming one geographical world. Beyond that, in the development and practice of systems engineering we have seen how specialists from many disciplines can be organized to work together creatively to produce new and effective arrangements, some of great complexity.

The communicators’ success with the practical application of complex knowledge should give much encouragement to the universities, to those of us who are concerned with the systematic organization of knowledge and with the communication of it to the younger generation. The methods by which this success has been achieved are also worthy of analysis and emulation for possible application to our educational problems.

Even if one is not ready to specify the millenium, one can work toward the goal it suggests. We hope that, eventually, all of knowledge will be charted and made accessible to anyone with the proper directory. It is to be hoped that some day professionals in one field will look upon all specialists in other fields as trusted colleagues and that they will take pride in learning to converse with them, at least about the broad significance and values of their fields. Perhaps we can also hope for the day when the most valuable thing we can give to our students is the understanding and the techniques by which they can utilize a single great communication network of knowledge.

Such an integrated intellectual world may seem remote, but it would be much closer if each scholar would accept one obligation in addition to that of becoming proficient in his own field. This additional obligation is to cultivate the links by which his field can communicate with others and to try to maintain as clear a perspective as possible as to the part his own field plays in man’s total intellectual adventure.

Essentially full text of an address at the IEEE International Communications Conference, Philadelphia, Pa., June 15–17, 1966.

A nonmagnetic laboratory for the National Bureau of Standards

A new facility being planned by the National Bureau of Standards may provide absolute determinations that eventually will permit reassignment of the world's voltage standards

Forest K. Harris National Bureau of Standards

The new laboratory to be built on the Gaithersburg, Md., campus of the National Bureau of Standards will provide a nonmagnetic environment that will permit absolute electrical measurements to be made. A brief review of the history of electrical reference standards since the creation of the Bureau demonstrates the importance of and need for such a facility.

Improvement in the assigned values of the United States' electrical reference standards is essential to further progress in many areas of science and technology, and therefore is of continuing concern to the National Bureau of Standards. Perfect agreement of these standards with their intended values—specified in terms of the prototype mechanical units of length, mass, and time—is, of course, an ideal that can never be completely achieved by any experimental procedure. However, we hope to move closer to this goal in a laboratory planned for the Bureau's new campus at Gaithersburg, Md.

The Bureau's new nonmagnetic laboratory is being planned to house three important classes of experiments:

1. The realization of a standard of inductance whose value may be computed from its measured dimensions and the assigned value of space permeability.

2. The absolute measurement of current in terms of the mechanical force between conductors that carry it.

3. A means for monitoring the stability of the national unit of current—the ratio of the NBS Volt to Ohm—by determining proton precession frequency in a magnetic field set up by unit current in a solenoid of fixed dimensions.

Further improvement of these experiments is possible in an environment where there are no ferromagnetic materials, where magnetic field gradients are very low, and where there are no extensive metal structures whose eddy-current circuits could couple inductively with those of the planned experiment. There are, then, two basic requirements for this laboratory: (1) the structure must be magnetically transparent, and (2) the building must be remote from disturbing fields such as those from networks that supply electric power to the other laboratories on the campus. It is also essential that the site be remote from heavily traveled roads, whose traffic can best be described

for our purposes as moving masses of ferromagnetic material that temporarily alter the field pattern.

The first requirement—magnetic transparency—precludes the use of most of the ordinary materials of construction. The second requirement—remoteness from activities that would disturb the magnetic field pattern—can be met only because the Bureau's new campus is nearly a square mile in extent.

A magnetic survey disclosed an area, remote from the main laboratory complex, in which the local field was reasonably uniform. At the site chosen for the new laboratory, the horizontal magnetic gradient, measured about 2 meters above the ground, amounted to about 3 gammas/meter—approximately two orders of magnitude less than the gradient in our old laboratory. (A gamma is a nanotesla.) The ambient 60-Hz magnetic field is approximately 3 gammas—again nearly two orders of magnitude less than the level in our present quarters during normal daytime operation. There are minor anomalies at ground level, associated with rock outcroppings that are somewhat magnetic; and, therefore, we had to consider two alternatives: (1) We could excavate the building site and its immediate surroundings to a depth of several feet and use nonmagnetic back fill. (2) We could build piers to a height of several feet above the ground plane and plan our laboratory rooms at this level. The latter course was chosen as being less expensive and less liable to hidden contamination.

The building will have redwood siding, plywood walls, oak floors, and vermiculite insulation between the inner and outer walls. The piers will be of limestone. Aluminum-alloy nails and aluminum or bronze hardware will be used in the construction. Ductwork for heating and air conditioning will be of plastic. The heating and air-conditioning machinery will be in a separate service building at a considerable distance, and a covered colonnade connecting the buildings will carry the air ducts for temperature control of the laboratory space. The service building will also house the storage batteries, which will be used as the source of constant direct current needed for the measurement program, and the electronic instrumentation and other equipment that cannot be tolerated in the nonmagnetic building. The service building also

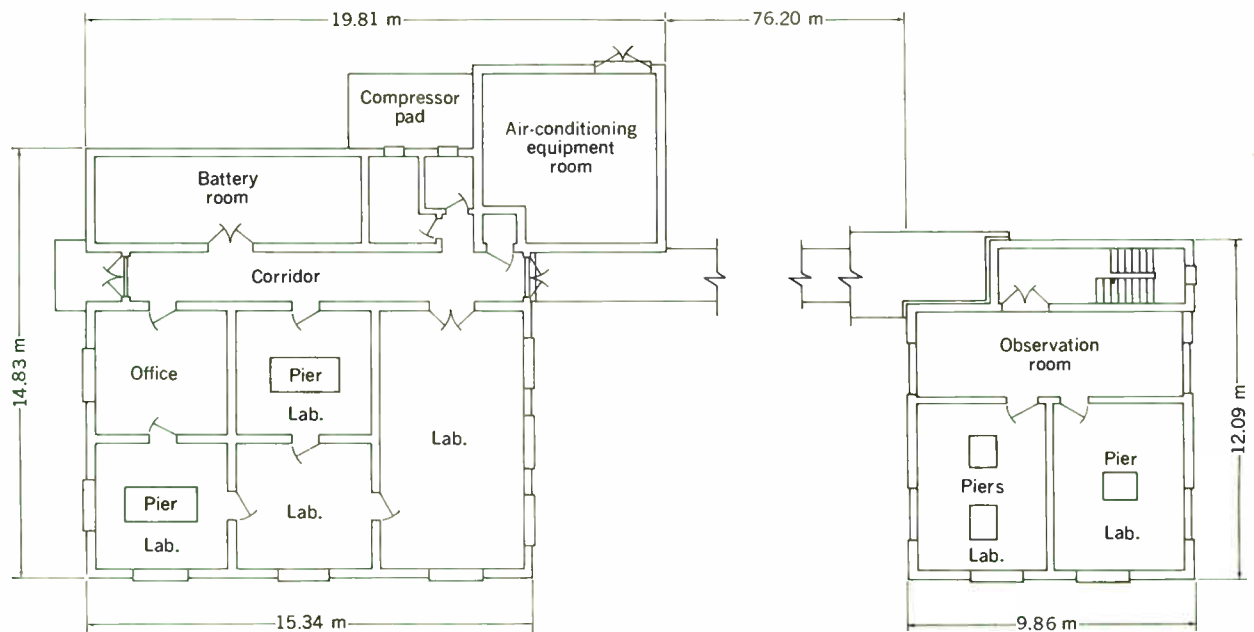

General arrangement of the National Bureau of Standards' nonmagnetic facility.

provides office space for the laboratory personnel, and a limited amount of laboratory space for experiments that are related to the main program but that do not require a magnetically clean environment.

Ampere determinations

The current balance and dynamometer that will be set up in the new laboratory represent classical approaches to the problem of determining the ampere in terms of the mechanical units—the meter, kilogram, and second—by measuring the force between current-carrying coils. The law of force for the current balance is $F = I^2(\partial M/\partial X)$, where M is the mutual inductance between a system of fixed coils and a movable coil suspended from one arm of an equal-arm balance. This force is balanced by the gravitational force acting on a known mass, so that $I^2(\partial M/\partial X) = mg$. In this experiment, the balance current is passed through a known resistance, and the resulting voltage drop is compared with the EMF of a standard cell. The end result of the measurement is the assignment of the standard cell EMF in terms of the absolute ampere and ohm. (The value of the ohm has been determined previously by comparison with the reactance of a calculable inductor or capacitor at a known frequency.)

Since systematic errors are difficult to avoid or evaluate in any single measurement procedure, redundancy of method is particularly desirable in an absolute measurement program; therefore, a second type of absolute-ampere experiment has been developed. In this determination, the measured current is carried by a fixed and a rotatable solenoid whose axes are at right angles and whose centers coincide—a dynamometer arrangement of a type first suggested by Pellat in 1887. The torque between the coils, given by the expression $T = I^2(\partial M/\partial \theta)$, is balanced by a known mass at a known distance from the axis of rotation.

The mean of ampere determinations made ten years ago—using our current balance and our Pellat dyna-

nometer—was reported as 1 NBS Ampere = $1.000\,010 \pm 0.000\,005$ Absolute Amperes. A reassignment of the acceleration of gravity, made after these values were reported, would increase the discrepancy between the NBS Ampere and the Absolute Ampere; and it now seems reasonable that the NBS Ampere should have been reported as $1.000\,012 \pm 0.000\,005$ Absolute Amperes.

Now the NBS Ampere is the ratio of the NBS Volt (as maintained by the group of mercury-cadmium cells that forms the national reference standard) to the NBS Ohm (maintained by the group of resistors that constitutes the national reference standard of resistance). Evidence from recent absolute-ohm determinations indicates that the NBS Ohm differs from the defined Absolute Ohm by less than one part in a million. Thus, it seems probable that the 1948 assignment of the national reference group of standard cells was incorrect by about 12 parts in a million, if we assume that the group mean has been constant over the interval.

There have been regular comparisons of the NBS Volt with that maintained at the International Bureau near Paris, which indicate that these two units have not drifted apart by more than three parts in a million since their common 1948 assignment.

Additional evidence concerning the stability of the national electrical units comes from proton precession frequency measurements made over the past six years. In this experiment a small water sample, whose proton spins are polarized in a strong magnetic field, is brought into the field of a solenoid excited by the NBS Ampere. The observed proton precession frequency is a sensitive measure of the solenoid field, and hence of the stability of the NBS Ampere, to the extent that the solenoid, which is wound on a fused silica form, is dimensionally stable. In view of other evidence that the NBS Ohm is stable, this experiment has been used to monitor the stability of the NBS Volt, and it appears that no change in excess of one part in a million has taken place in our voltage reference

standard over the six-year period.

One may hope that the nonmagnetic facility will make it possible to improve the accuracy of our absolute-ampere measurements—perhaps contributing to a better international assignment of the volt—and to improve our ability to monitor the stability of the national electrical units.

An improved inductance standard

Another experiment scheduled for the nonmagnetic laboratory—an improved calculable inductance standard—can have a further important consequence if it can be refined to the part-in-a-million level or better. It can lead to an electrical determination of the speed of light, the first time such an experiment has been considered seriously at NBS since the classic ratio-of-units determination by Rosa and Dorsey in 1906. It is now quite feasible to assign the value of a computable capacitor to a part in 10^7 or better (excluding uncertainty in the value of vacuum permittivity) using the geometry prescribed by the Thompson-Lampard theorem. If an inductor, computable from its dimensions and the assigned value of space permeability ($4\pi \times 10^{-7}$ in the MKSA system of units), were compared with such a capacitor in an appropriate bridge, a speed-of-light value could be obtained, since the square root of the product of space permeability and permittivity is the reciprocal of the speed of light in free space, $\sqrt{\mu_0\epsilon_0} = 1/c$. To be of practical significance in the assignment of this important physical constant, such a determination of c must depend on the availability of an inductor whose value can be assigned to a part in a million or better. This would have to be the goal of the computable inductor experiment in the new laboratory.

Historical background

At the same time as we examine plans for use of the laboratory facility that will be available to us in Gaithersburg for improved absolute measurements, it may be of interest to review briefly the past history of our electrical units. The validity of the national electrical reference standards, and their agreement with those of other countries, have been a core element of the Bureau's standards program for more than half a century.

The situation that existed in 1901 when the Bureau was created was anomalous. The Congressional Act of 1894, defining the electrical units in conformity with current international practice at that time, recognized that they should be based on the mechanical units of the metric system, but as a practical expedient defined the ohm in terms of a specified mercury column, the ampere in terms of the rate of deposition of silver from a specified electrolyte, and the volt in terms of the EMF of a cell made in a prescribed way; the experimental realization of each of the three quantities related by Ohm's law was independently prescribed. This awkward situation existed in the United States and other countries until 1908, when an International Conference under the chairmanship of Lord Rayleigh resolved that the *ohm* and *ampere* would be considered the "primary" units, and the volt would be defined in terms of them.

In 1910, representatives of the national laboratories of Germany, Great Britain, France, and the United States met at the Bureau of Standards in Washington. Using the "mercury ohm" and "silver ampere" specifications of the 1908 Conference, they assigned values to a number

of resistance standards and standard cells. These standards, embodying the "Washington Units," were divided among the four laboratories and were intended to be the national reference standards from that time on.

Following their establishment in 1910, the units maintained by the various national laboratories were compared occasionally until World War I interrupted such international amenities. By the early 1920s, it was abundantly evident that the reference standards of the various countries were drifting apart to a serious extent. Some of the national laboratories reassigned their units on the basis of new mercury ohm and silver ampere experiments during the next decade, and a rather general feeling developed that the silver ampere and mercury ohm might not be "reproducible" to the extent required by science and technology.

Perhaps the first official action by a responsible technical group was a resolution adopted by the Board of Directors of AIEE pointing out that the existing situation was not satisfactory and urging the national laboratories to undertake research to reduce the discrepancies within acceptable limits, and to undertake "as soon as possible, the additional researches necessary in order that the absolute ohm and absolute ampere... with... the other units derived from them be legalized in place of the international ohm and ampere and their derived units."

The 1933 General Conference of Weights and Measures was in agreement with this position and authorized the International Committee on Weights and Measures to fix the ratios between the "International" and "Absolute" units, and to set a date for adoption of the new units when enough absolute-measurement results were available. At its 1935 meeting, the International Committee fixed on January 1, 1940, as the time for adopting the absolute units, and in June 1939 its Technical Advisory Committee—made up of representatives from the national laboratories—met, reviewed the absolute-measurement data then available, and confirmed the transition date set by the International Committee. However, nothing was done until the end of World War II.

In 1946 the International Committee set a new date, January 1, 1948, and fixed the ratios of the international to absolute units. In conformity with these resolutions the Bureau reassigned the values of the national reference standards, decreasing the ohm by 495 parts in a million and the volt by 330 parts in a million; the remaining units were correspondingly modified. Thus the "International" units, which had been maintained by the National Bureau of Standards over nearly 40 years within about 20 parts in a million, passed from the scene and the Absolute units became the basis of the National Reference Standards. The 1948 assignment is presently in use; and large discrepancies between U.S. units and those of other nations are guarded against by periodic comparisons of standards at the International Bureau.

During the nearly two decades that have elapsed since the 1948 assignment, a number of absolute determinations have been reported from several of the national laboratories, including our own; and considerable evidence has accumulated that the 1948 assignment of the voltage standard was incorrect. Thus, the ampere determinations that we expect to make in the Bureau's new nonmagnetic laboratory may contribute to an international decision to reassign the world's voltage standards and bring them closer to the intended absolute unit.

M.I.T.–NASA Working Conference on Manual Control

Laurence R. Young *Massachusetts Institute of Technology*

Roger Winblade *National Aeronautics and Space Administration*

Advanced and increasingly complex vehicles developed in recent years for transportation on or near the surface of the earth as well as in outer space and below the sea place enormously increasing demands on the man-machine interactions associated with piloting these vehicles. The development of versatile and reliable automatic control equipment also forces a re-examination of the appropriate roles of men in controlling these complex systems. One consequence of this trend is that systems engineers seek more quantitative descriptions of the behavior of humans in tracking and control tasks, descriptions compatible with conventional engineering design specifications, so that the effect of the "man in the loop" might be readily evaluated and potential problems avoided.

Although application of control theory to manual systems was begun both in England and in the United States during World War II, it was not until the 1950s that a significant number of researchers in the United States turned their attention to the problem of generating mathematical models for the human operator. A series of informal conferences of the engineers and psychologists working on these problems, known as the *Annual Manuals*, was begun in the late 1950s. By 1964, the growing number of interdisciplinary workers in the field convened at the University of Michigan–NASA Manual Control Conference held in Ann Arbor. In 1966, an attempt was made to bring together the engineering psychology specialists who have been developing more advanced models of the pilot in a control loop and some of the engineers concerned with application of such models to designs of advanced man-vehicle systems. Approximately 100 people attended the three-day M.I.T.–NASA Working Conference on Manual Control at Cambridge, Mass., February 28–March 2. The conference was organized and chaired by the authors of this report.

Laurence R. Young is an assistant professor in the Department of Aeronautics and Astronautics and Man-Vehicle Control Laboratory, M.I.T.; Roger Winblade is manager of the Manual Control Research Program at NASA Headquarters, Washington, D.C.

Most of the manual control experts agree on the adequacy of a quasi-linear describing function (a form of specialized transfer function) model for the human operator for the following type of situation: he sees only a display of the error signal, and he performs a single-axis tracking task with reasonably well behaved and nontime-varying plant dynamics (i.e., constant plant dynamics). Such quasi-linear models consist of a variable dead time, variable lead and/or lag time constants, a fixed neuromuscular delay and variable gains, plus an additive remnant term representing the portion of the operator's output not linearly correlated with the input. The variable parameters have been catalogued for a wide variety of plant dynamics and input spectra.

The Cambridge conference, consequently, emphasized the development of other models to describe human operator behavior in greater detail or in multiple-loop, multi-axis, time-varying, or deliberately nonlinear tracking situations. It stressed, as well, the application of our notions of tracking ability to a variety of vehicle control tasks. The formal program was divided into nine sessions, some of the highlights of which are described in the following.

Discrete and continuous models

With the general acceptance of the quasi-linear model for design purposes, the emphasis in this session was on the "fine structure" of the operator's behavior. Curiously enough, there was no further discussion of simple sampled data models to describe either transient tracking behavior or the "sampling peak" in the operator's remnant power spectrum. G. A. Bekey and E. S. Angel proposed a class of a synchronous finite-state models in which the input and output of the operator are assumed quantized rather than continuous, and the operator himself is modeled by a simple finite-state machine performing asynchronous switching among states. Although input and output quantization and on-off operation have long been observed, the techniques for synthesizing finite-state models are in their infancy and consequently no judg-

ments as to their possible usefulness can be made at this time.

In a new study of an old problem, R. W. Pew, J. C. Duffendack, and L. K. Fensch investigated tracking of single sinusoids under various control and display gains and display modes. They verified a prediction of the McRuer and Krendel "successive organization of perception" model, showing that with increasing practice the subjects used the coherency of the input to track with a compensatory display (one in which only the error is displayed) in a manner similar to tracking with a pursuit display (in which input, output, and error are displayed). In an attempt to create a "rational parameter model" (that is, one in which the parameters of the model are selected rationally in terms of the known biophysics of the system), D. T. McRuer presented a preliminary neuromuscular model for hand movement. Considerable interest was shown in the relations between the "neuromuscular wiring diagram" and observed tracking performance.

Adaptive control

In parallel with the interest in automatic adaptive control, the study of these characteristics of man (the archetype adaptive controller) began recently and has been intensified in the past few years. Attempts to observe or explain the changes in human tracking behavior as the plant dynamics suddenly fail or otherwise undergo a rapid change have been hampered by the inability to track the "human control law" during the brief period of active adaptation. Three papers in this session specifically treated the problem of modeling human adaptive behavior following rapid changes in plant dynamics. The phases of the adaptive process are detection of a change in plant dynamics, identification of the nature of the new dynamics, modification of the operator's control law to reduce the accumulated error consistent with the new situation, and optimization of tracking characteristics to bring the long-term performance up to asymptotic level. J. I. Elkind and D. C. Miller emphasized the first of these phases. Using a model reference-type adaptive control scheme, they proposed a model in which the man compares the actual error rate over a sampling period with the error rate he would have expected based on his knowledge of his control movements and an internal representation of the plant dynamics. When the difference between these predicted and observed error rates exceeds some criterion level, the model predicts detection of a change in plant dynamics and enters an identification phase. Experiments on actual detection time following controlled element transitions support this theory. E. E. Gould and K. S. Fu directed their attention to the modeling of the identification phase of the adaptive process, proposing that the operator use pattern recognition techniques to identify the order of the system being controlled. They presented a model based on linear decision theory that chooses position, derivative, or integral control. Although no experimental validation was available, the combination of the approaches of these two papers should yield a testable model for the detection and identification phases.

D. H. Weir and A. V. Phatak modeled the human adaptive response to transitions in controlled element (i.e., plant) dynamics in a descriptive manner that avoids the question of how the operator decides when a change

occurred and what the change was. The method may prove quite useful for *ad hoc* studies of accumulated error during particular system failures. They assumed that the appropriate human control behavior for the pre- and post-transition dynamics are known, and that the main problem is merely when and how the operator switches between the two. System error typically diverges while the operator continues tracking with his pretransition control law. Weir and Phatak hypothesized that once detection and identification occur, the operator reduces the accumulated error in an optimal, or near-optimal, manner until it reaches a level where steady-state transition control may be used. Such an approach, if validated experimentally and supported by reliable tables of expected duration of pretransition retention periods (the time from the change in plant dynamics until the operator begins to change his control law or behavior), could permit estimation of what happens to a manual control system following changes in vehicle dynamics.

A more general approach to the man-machine adaptive control problem was taken by Y. T. Li, who emphasized the trade-off between speed of adaptive control and the use of precisely defined performance indexes.

Information theory

Since Shannon popularized the information theory approach to transmission and processing of signals and noise in communication systems nearly 20 years ago, there have been repeated attempts in mathematical psychology to characterize the human as a fixed-channel-capacity information processor. The obvious advantage of such a characterization would be the ability to assess the work load imposed by a variety of subtasks in terms of the number of bits per second required and the human capacity limit. Human transinformation capacity (the capacity of the person to receive, process, and transmit information) was measured for simple decision tasks and for jobs such as sending or receiving code, typing,

Fig. 1. Relative error versus parameter variations for noiseless model showing operator's average performance.

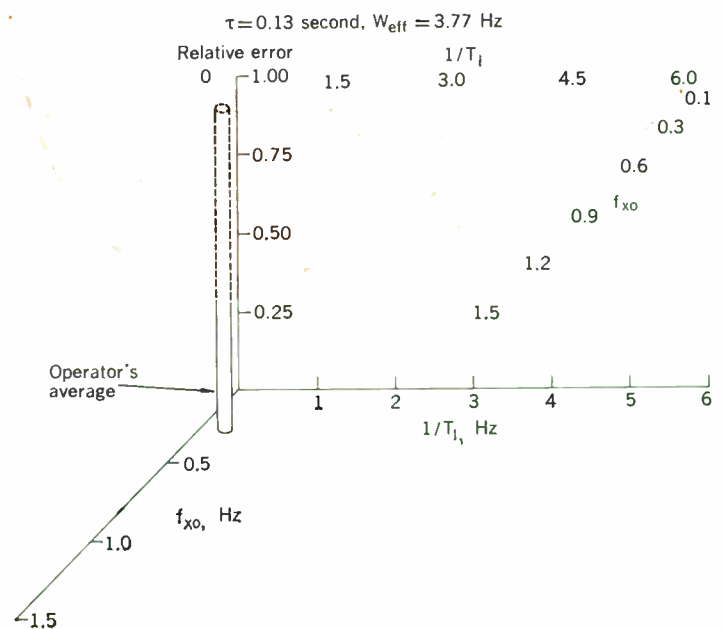

and piano playing. As regards characterization of human operators in a tracking task, however, the application of information theory had yielded disappointingly few usable results, and has been virtually neglected in the literature for the past five years.

T. Wempe and D. Baty took a fresh look at this problem in an effort to determine the usefulness of transinformation as a human tracking measure. In attempting to define an appropriate measure of information for the human tracking task, they concluded that the traditional communication concept (which examines how closely the operator's output reproduces the input) is not appropriate since it does not penalize the instantaneous error, or shifting of the waveform resulting from the operator's delay. Wempe and Baty proposed an alternate definition of transinformation, considering the effective bandwidth of the input signal and the correlation between input and the in-phase component of output, and they compared it with experimental tracking results. Although this transinformation formulation agreed with the subjective opinion relative to task difficulty and ability to accomplish the task, it was not successful in predicting the operator's control law. Rather, the control characteristics assumed by the operator seemed to be such as to minimize relative error, just as is assumed in most of the quasi-linear describing function models for the operator. Figure 1 shows how the operator chooses a time constant (T_I) and gain crossover frequency (f_{co}) for a given task, which seems to minimize approximately the relative error. The tentative information processing model suggested by Wempe and Baty predicts a human capacity of about 7 bits/second, which is consistent with the higher estimates of other investigators for different human tracking tasks.

E. Krendel gave an interesting commentary on this approach. He reviewed some of the history of the application of information theory to tracking tasks, and predicted that since the human does not act as a communication channel, attempts to gain insight into his performance or capabilities through the use of information theory will continue to be rather fruitless.

Two papers of a slightly more applied nature that related information theory to tracking were included in the session. J. W. Senders analyzed the task of automobile driving from an information processing point of view, building a model on the basis of some fascinating road tests. By controlling the number of samples of information available to a driver, through a visor that occluded the driver's vision except at sampling instants, Senders was able to relate the sampling frequency, information content in the curvature of the road, and driving speed.

P. Gainer discussed the usefulness of information descriptions of the human operator as a performance index, and its relation to an individual's ability to perform a tracking task. Gainer was confronted with some of the same problems mentioned above in attempting to define an appropriate expression for human information capability. He concluded that some insight into human performance capability is offered by an information input measure, which is not available in the conventional describing function description, but agreed that further research is necessary to determine what measures of information transfer the operator considers important or relevant.

Multivariable control

Another topic of increasing interest in recent years has been multivariable control, or the ability to model the performance of a human operator when he is sharing his attention among several loop closures of a multiloop system or among several axes of a multidimensional problem. The approach that has been universally adopted is to consider the single-loop operator performance characteristics for a given set of vehicle dynamics and observe how these characteristics are modified, if at all, when additional loops or axes are added to the task. The four papers in the session on multivariable control all dealt with investigations using this approach.

E. P. Todosiev, R. E. Rose, and L. G. Summers studied the symmetrical two-axis problem, in which identical second-order dynamics were used for both x and y axes. Comparison of single-axis and two-axis tracking revealed no differences in error scores for the relatively simple dynamics considered; however, an interesting difference in the pilot model was found for the case of two-axis tracking with the more sluggish system. In order to maintain the same level of error performance as in single-axis tracking, the operator was forced to adopt a significantly greater lead time constant for two-axis tracking. (This increased lead might reflect the effect of sampling two input channels, which requires the operator to extrapolate the error on the unattended channel by means of velocity estimates.) In a related set of experiments, W. H. Levison verified that two-axis performance degradation is small when the tracking conditions are homogeneous, whether the inputs to the two axes are the same or different. However, when the dynamics in the two axes are different (position control and acceleration control), the effects on system error are large and significant, increasing the normalized mean squared error from 15 to 125 percent. Furthermore, the subject describing functions show important changes in this case. Levison suggests that there are three major factors—namely, eye-hand coordination, sharing of attention among different tasks, and similarity of the form of the different tasks—that must all be considered in deciding upon modification of the single-axis models for multiaxis tasks.

A somewhat different problem is presented by the multiloop task, which was investigated by R. L. Stapleford, D. T. McRuer, and R. Magdeleno, who used lateral aircraft control (bank angle and yaw velocity) as a test situation. They recorded error, describing functions, and pilot opinion for the multiloop control situation, and concluded that the quasi-linear pilot model and adjustment rules, which had been developed for single-loop systems, are in general applicable to multiloop system command loops. For simultaneous closure of an inner loop, however, the single-loop pilot models may be applied only with some reservations, and the ability to increase performance through use of a cross-feed from one loop to the other must be accounted for. These authors also found that in this multiloop situation the tracking errors can be kept down to the level of a single-loop task; however, subjective opinion is degraded.

The final paper in the session, by J. J. Adams, reported on experiments involving the pilot in multiloop tracking tasks in combination with side tasks. Adams used multiloop tasks that were representative of altitude and horizontal translation control of a LEM vehicle. For

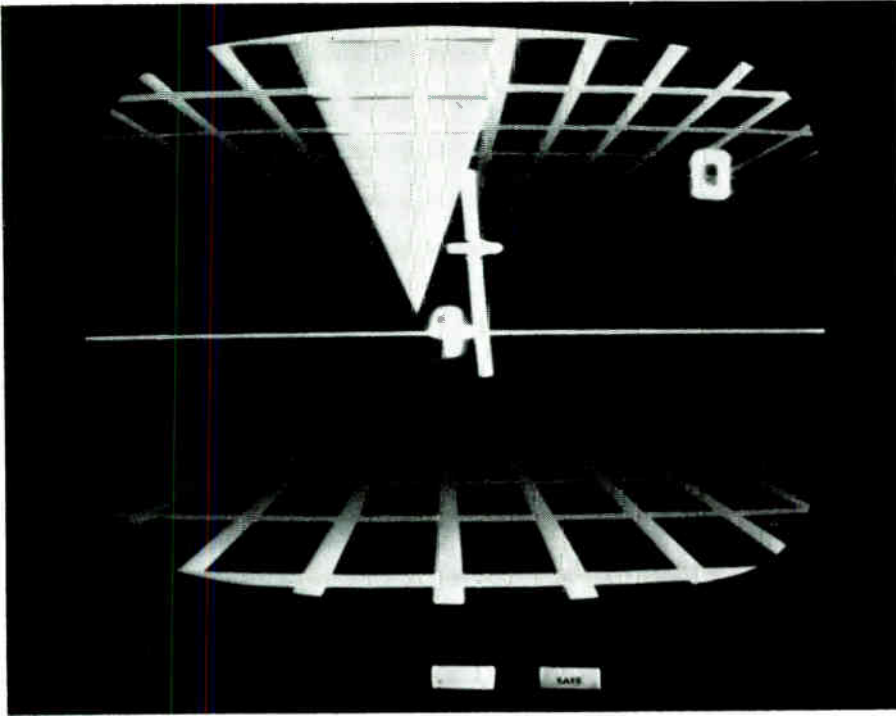

Fig. 2. Simulation of the Norden contact analog perspective quickened display for submarine control.

multiple-loop control of vehicle pitch and translation, simple pilot models for each loop are useful. Adams showed that some of the multiloop characteristics could be easily reproduced if one included switching in the model of the human controller, representing a duty cycle, or periods of neglect of control in the inner loop.

Displays

Human performance in a control task is directly affected by the method used to display information about the controlled element. The fifth session included three very different approaches to the problem of information display.

R. L. McLane discussed the results of a program designed to examine differences in submarine control performance as a function of display format. The two formats investigated were the pictorial contact analog (a simplified perspective picture of the external world) shown in Fig. 2 and the symbolic depth azimuth display (a collection of coded circles and dots representing vehicle and target information). The results of this very thorough study point up the lack of sensitivity in current performance measurement techniques. The lower tracking error scores achieved on the pictorial display could only be considered a general trend, rather than a statistically significant difference in all cases.

J. C. Bliss described the results of a series of tracking experiments using the tactile sense modality as the channel for displaying information to the controller. In the experiments tactile information was generated by a series of air jets located above the outstretched index finger when the hand was placed on the manipulator. The subject attempted to maintain the air jet above the first knuckle of the index finger. Bliss compared performance with the tactile display and a comparable visual display in which the air jets were replaced by small light

bulbs. The results indicate that the reaction times in tracking tactile step inputs may be slightly less than with the visual system and, in addition, the tactile display appears to reduce the tendency to overshoot when the subject is presented with more complex dynamics. While currently more difficult to mechanize, the tactile display appears to offer a feasible means of providing control information, particularly in situations in which visual information cannot be presented.

The final presentation in this session was made by W. R. Ferrell, who described the results of a study that examined delayed force feedback. The experiment was a simulated remote manipulation task with force feedback through the controller; its objective was to examine the effect of the force feedback cue when the operator is faced with a relatively long transmission delay in the system. The apparatus consisted of a one-dimensional remote positioning device; the forces were measured by strain gages and fed back to the operator by means of a motor connected to the controller. This study indicates that the inclusion of force feedback in remote manipulators is feasible in spite of long transmission delays. However, the forces should be displayed to the operator without affecting the movements of the master control.

Motion and stress

The effects of motion and stress on control performance is a complex subject. Human physiological limits are reasonably well known from a design criteria point of view or, at any rate, limits have been established and accepted by system designers. Below these limits, however, the effect on control performance of various types and levels of stress is not clearly defined.

Whereas it is certainly true that the addition of high levels of sustained acceleration or vibration to a control

task will degrade performance, L. R. Young described several areas where control performance is enhanced through the use of motion cues by the controller. Specifically, the control tasks that appear to benefit most from the addition of acceleration and motion cues are those situations requiring more lead compensation than is easily developed from visual displays. The additional information, presented to the controller through vestib-

ular and tactile sensations, was also shown to be significant in his adapting to a rapid change in controlled element dynamics. A plot of a compilation of data from several sources, shown in Fig. 3, indicates the relative effect of motion cues on controllability as a function of the controlled element dynamics.

Not all acceleration cues are beneficial even though they are well below the accepted physiological limits. Included in the studies reported by M. Sadoff were data to show that under short-term zero gravity, while simple reaction time is essentially unaffected, the complex reaction time is significantly increased. The increase in percentage of control reversals that occur at 0 g and +3 g parallels the increase in complex reaction time for those same levels, and lends additional support to the possibility of "central processor" changes due to weightlessness. On the opposite end of the scale, the analysis of pilot performance under sustained linear acceleration with a superimposed 1.5 g, 11-Hz vibration suggests that the required lead equalization disappears during severe vibration.

Pursuing the vibration environment as a very probable stressor on the control task, A. Z. Weisz presented an evaluation of three types of hand controllers under random vertical vibration. In general, the results of the study agreed with previous efforts in that the force stick concept did provide superior performance.

Indicating the complex interactions and substitutions of cues that occur within the human controller, Mrs. H. L. Smith presented the results of a series of tests conducted in the Cornell Aero Labs Variable Stability T-33. As described, the tests were conducted in flight, on the ground using the aircraft as a fixed-base simulator, and in a conventional analog simulator that included a contact-analog-type visual display. Analysis of the pilot response data indicated that the analog simulator and visual display gave results closer to the flight situation than did the actual flight hardware when operated as a ground-based simulator, even though the controlled element dynamics were identical in all three cases.

In measurements of the effect of stress on performance not only is the problem compounded by the multiplicity of types, but as the levels of application are reduced, the investigator rapidly encounters a problem in sensitivity of the available performance measures. To ease this latter problem, C. C. Gibbs evaluated the effects of minor stress, such as low levels of alcohol or minor frustration, on automobile driving performance. Gibbs' measures were the response latency and correct versus incorrect responses while the subjects were tracking step functions. The sensitivities achieved were quite impressive; it was possible to identify performance impairment caused by one bottle of beer several hours after the subject had drunk it.

Applications

Examples of the application of human dynamics were given in four informal papers dealing with the design or analysis of specific systems, such as manual booster control and VTOL control. In addition, C. B. Westbrook discussed the present and future applications of pilot dynamics data in flight control system design and development. His salient point was that while valid controversy still exists over specific details, and much work is still needed to relax the constraints on existing techniques,

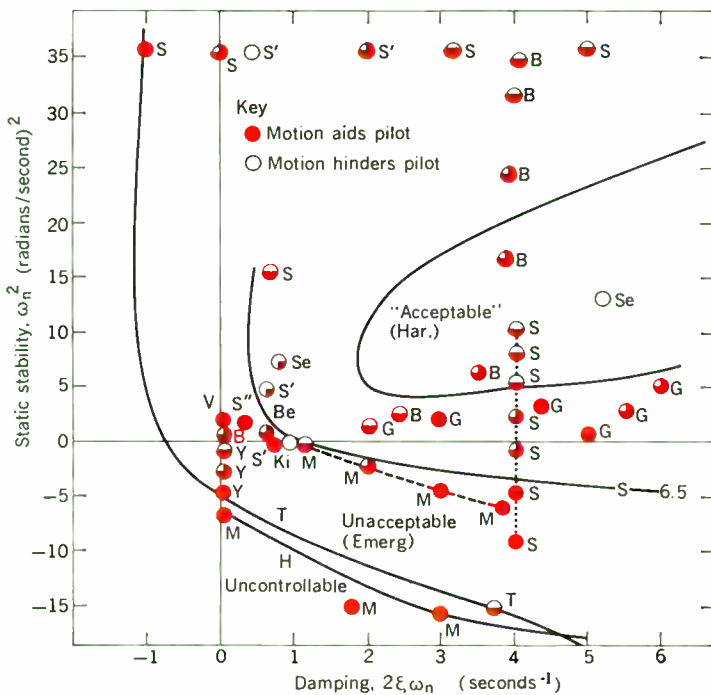
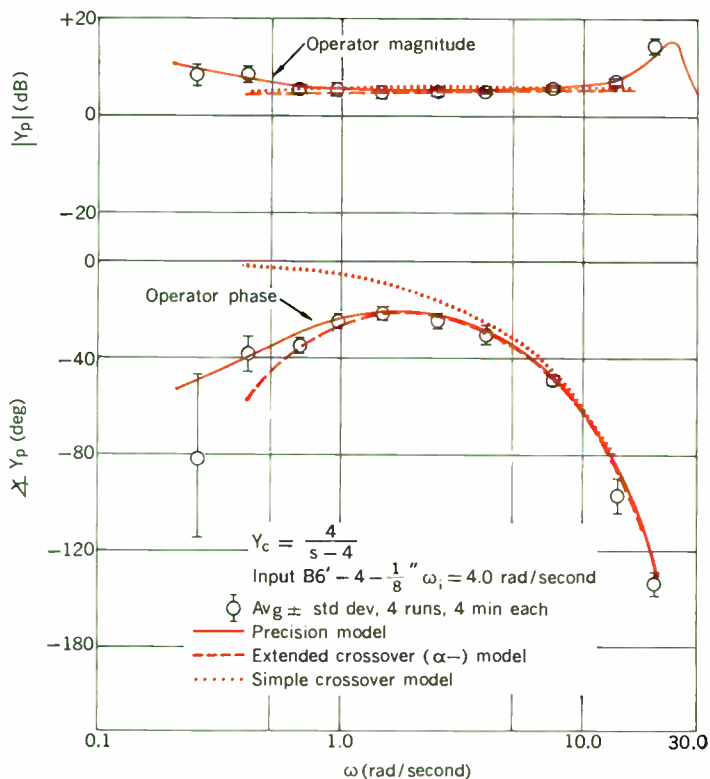

Fig. 3. Effect of motion cues on pilot performance.

Fig. 4. Mean data and curve fits for one operator's describing function in a critical task ($\lambda = 4$).



the current capability has been proved, and more emphasis should now be shifted toward design applications.

Optimal control

Modern optimal control theory generally requires that the criteria to be optimized be specified prior to system synthesis. Since theory makes no attempt to define a universally optimal system, it is possible for any control system to be optimal if the criteria are defined appropriately. Consideration of the human in a manual control task as an optimal controller then must center about determining what criteria are being adopted since system synthesis is a somewhat remote possibility.

T. B. Sheridan proposed a model of human behavior in a preview control task in which the "road ahead" may be seen. The model he used in two exploratory experiments illustrates some relevant experimental variables and roughly compares the human operator to an optimal preview controller. The experiments suggest that for a relatively difficult control task, the human operator is reasonably close to optimal and trades off error with effort in a rational fashion. Further, human control in a preview task may be suboptimal for several reasons—for example, insufficient experience with the controlled process or explicit cost function, use of an implicit cost function differing from that stipulated, or inability to see and remember the previewed input adequately.

F. A. Muckler discussed an experiment designed to investigate further the ability to state explicitly the performance criterion to be used in a tracking task. The study employed a constant set of dynamics and used the same control and displays throughout, with the variable being the explicit performance criterion. From the data, it was clear that while no changes in forcing function or controlled elements were made, several distinct shifts in operator behavior occurred; that is, the same subjects can perform the same basic task differently. It follows that if a particular performance criterion is desired, it must be adequately conveyed to the subject. In addition, it is possible for subjects to perform according to some implicit criteria regardless of what is requested, resulting in extreme intersubject variability.

R. E. Thomas and J. T. Tou proposed an approach to modeling the decision process. Their model attempts to describe how a human operator exhibits on-line adaptive behavior in a control system. No repeated trial is permitted in the decision-making process while the subject solves the optimal control problem; consequently, the model is only concerned with on-line learning. The primary difficulty seems to center around the question of the extent to which a human controller can be characterized as a Bayesian decision maker. The characteristic framework of the proposed model results in a search algorithm that generates a control strategy and finally control actions by minimizing the incremental "cost."

The pursuit-evasion differential game examined by S. Baron gave a direct comparison between an optimal pursuer and a human controller. The studies were not directed toward a study of manual control; as a result, the information gleaned from this effort was mostly qualitative. A point of significance, consistent with the results of Sheridan and Muckler, was the marked improvement toward optimal control as the test subject became more aware of the required strategy. This was evident after the subject was permitted to view the optimal

pursuer several times prior to making manually controlled runs.

Analysis and design methods

The final session of the conference covered a broad range of subjects, from the application of modern control theory to human operator model development, to the development of a performance prediction of a digital computer facility for flight simulation studies. In a description of dynamical system modeling, P. L. Falb and G. Kovatch suggested the possibility of using results from modern control theory in developing differential, difference, and integral equation models for human operator behavior in a control system. The very powerful analytical techniques developed in the modern control theory field have the potential of giving greater insight into the human performance modeling problem than previously possible.

Two papers dealt with the use of variable system dynamics as a means of analyzing human performance. The "critical task," described by H. R. Jex, records subject tracking performance in a task with a programmed variation in dynamics that increases in difficulty until control is lost. Data taken in this manner, represented by Fig. 4, show that near the limit of control the subject's behavior is adequately represented by recently formulated human operator models and adaptation laws. The adaptive simulator technique described by C. R. Kelly again uses variable system dynamics. However, in this instance, the difficulty of the controlled element dynamics is established as a function of the subject's instantaneous error in a self-paced task. The steady-state level of difficulty a subject accepts appears to be an effective means of comparing control and display systems. As was pointed out by Kelly, great care must be taken in selecting and mechanizing the parameters and rationale of the task adjustment.

L. W. Taylor's paper, "Discussions of Spectral Human Responses Analysis," was one of the most controversial presentations at the conference. Taylor stated that the pilot describing function estimate, which consists of the ratio of the cross-spectral densities from input to pilot output and displayed error, is equal to the ratios of the Fourier transforms of pilot output and error. The estimate using the power spectral densities was thought to be free of bias, and was shown to be equal to the ratio of Fourier transforms under certain conditions, especially when the input is a sum of sine waves.

The discussion from the floor was quite thorough; it was concluded that the presented expressions for the pilot describing function as a ratio of Fourier transforms is a valid interpretation when: (1) the input is a sum of sine waves; (2) the transforms are evaluated using the same sine and cosine functions for both transforms over the same run length; and (3) the transforms are evaluated only at the input frequencies. Within these restrictions, the technique will yield valid results and does offer some computational advantage; however, the validity of any generalization beyond the restrictions is questionable.

The final paper, by M. C. Grignetti, discussed the analysis and design of a computer facility for flight simulator studies through the use of a Markov model.

The proceedings of this conference are being published as a NASA Special Publication.

IEEE publications

scanning the issues
advance abstracts
translated journals
special publications

Scanning the issues

Automatic Control. Four papers in the current issue of the IEEE TRANSACTIONS ON AUTOMATIC CONTROL should be called to the attention of the general reader. Two are design studies and two are surveys. All are quite readable and informative.

The first of the design papers, "Optimal Helicopter Station Keeping," by Edmund G. Rynaski, is interesting in that its author compares a design based on optimal control theory with one based on conventional analog simulator studies. Rynaski uses modern control theory to treat an automatic formation flying problem of helicopters (Short Range Station Keeping). Briefly, a command helicopter sends out signals to each "slave" helicopter to maintain a fixed position relative to itself and to the other slave helicopters. An inner control loop is needed to minimize errors between the commanded and the actual position relative to the master. In this sense, the loop is designed to make the helicopter act as a regulator. The author points out that the convenience and efficiency of the optimal approach, once the control systems engineer has become familiar with its use, allows the engineer the flexibility and freedom to evaluate many variations of a design in the same time period required to muddle through one trial design by conventional techniques. In the example worked out by Rynaski, the conventional design required two months of painstaking multiloop analysis, whereas the optimal design could have been done in two days of routine analysis and digital computation. Both approaches used a similar performance criterion. The difference, Rynaski concludes, is awareness—the engineer who performed the conventional design was unaware that he was using an optimal criterion, whereas his counterpart was fully conscious of the criterion. Linear optimal control techniques, the author goes on, can be used to advantage when the

design requirements can be instinctively related to a performance index.

The second design paper, "On the Optimal Error Regulation of a String of Moving Vehicles," by W. S. Levine and M. Athans, like Rynaski's, involves the problem of station keeping, and it demonstrates once again the power of modern control theory. The authors employ the theory of optimal control to design an optimal linear feedback system that regulates the position and velocity of every vehicle in a densely packed string of high-speed moving vehicles. In addition to the general theoretical formulation and solution of the optimization problem, analog computer simulation results are presented for the case of a string of three vehicles.

The pertinent application of the study is to the high-speed train system being considered for the region between Boston, Mass., and Washington, D.C. The authors consider the incremental acceleration and deceleration program of every vehicle in a string of many vehicles. They derive their specifications from safety considerations, capacity requirements, velocity control, passenger comfort, and fuel economy. Although the authors make certain simplifying assumptions in this study, they believe its results can serve as guidelines for future research, which ought, among other things, to establish additional properties and suboptimal designs for a string composed of many vehicles.

One of the authors of the high-speed train study, Michael Athans, is the sole author of a whopping big survey, "The Status of Optimal Control Theory and Applications for Deterministic Systems," the perusal of which may gratify many kinds of readers.

Athans relates that over the past five years, system optimization has been the subject of intense research, many fine books have been published on the subject, schools are offering formal courses, which are well attended by students

from all branches—engineering, mathematics, economics, management, computer sciences, etc.—and many industries and research labs are attacking engineering-type problems using the concepts, techniques, and tools of modern control theory. In other words, the field of optimization has reached a certain state of maturity, and it is regarded as one of the areas of most fervent research.

Athans' survey is threefold. He discusses recent theoretical developments in the area of deterministic optimal control and sketches out possible future theoretical trends; in a section on applications, he presents several practical problems that are being investigated using the theory of optimal control; and he presents a list of references.

How has system optimization research reached such an intense pitch in so few years? Athans says that the need for additional theory in optimization arose to a large degree from the stringent requirements of aerospace systems, which are inherently nonlinear. They are subject to such constraints as limited thrust capability, acceleration constraints, fuel limitations, etc. Before the development of "modern control theory," the only other body of theory available for control was that dealing with the analysis and design of servomechanisms. However, servo theory was not adequate for the analysis and design of aerospace systems because most of the available tools could be applied only to the analysis and design of unconstrained, single-input single-output, linear, and time-invariant systems. Moreover, most of the useful tools of servo theory focused on the relative stability of the closed-loop system; the design tools were graphical and qualitative, and the design process was mostly done by trial and error, under the assumption of zero initial conditions. But with the coming of the digital computer, the control engineer was liberated from the philosophy that only simple, closed-form solutions are practical; and the more powerful computers helped create the need for