

# IEEE spectrum

## features

- 55** Spectral lines: Optimism and professional ethics  
*A distinctive quality of engineers is their sense of morality; as early as 1912 a code of ethics was drawn up by an AIEE committee that included Charles Steinmetz*
- + **59** IEEE launches program for new and expanded services  
William G. Shepherd  
*In addition to initiating new continuing education and information services programs, the 1967 allocations reward increased participation at the Section and Group levels*
- + **64** Compatibility—A challenge to universal communications  
*The first transoceanic radiotelephone communication dates back more than 50 years, but six experts here agree that technical incompatibility impedes future progress in the field*  
Global cables and satellite communication T. B. Westfall  
Progress in worldwide telephone dialing Lowell F. Wingert  
The CCITT and automatic worldwide telephony Marc Lambiotte  
Compatibility in world communications R. H. Franklin  
The role of Comsat in international communications Asher H. Ende  
U.S. military worldwide communications James H. Weiner
- + **82** The future of energy supply B. C. Hicks  
*It would appear that resources are available to satisfy our energy demands; the question is whether the resources can be applied in the ways required*
- + **89** Industrial radio telemetry C. H. Hoepfner  
*Signals from a missile-launched space probe soaring toward the sun are often easier to obtain than measurements from inside an earthbound motor that may be only a foot or two away*
- + **94** Ocean engineering: probing the depths of a wild frontier  
Gordon D. Friedlander  
*Scientists and engineers are cooperating in seemingly fantastic projects in the conquest and exploitation of the briny deeps*
- + **106** Prime-mover response and system dynamic performance  
C. Concordia, F. P. deMello, L. K. Kirchmayer, R. P. Schulz  
*Closer attention to the response capabilities of various units and to the spreading of governing duties uniformly among many units will help reduce the severity of system upsets*
- + **112** The philosophy of engineering Henry Greber  
*Since the days of ancient Greece, no complete philosophy of engineering—by engineers—has evolved. Perhaps this viewpoint may be a “famous first”*
- + **116** Real-time digital analysis system for biological data  
J. Ryland Mundie, H. L. Oestreicher, H. E. Von Gierke  
*The study of a neuron is but one of many instances in biological research in which “instant results” are not only desirable but necessary to the experiment*
- 56** Authors  
Departments: *please turn to the next page*



THE INSTITUTE OF ELECTRICAL AND ELECTRONICS ENGINEERS, INC.

## departments

9	Transients and trends		
10	IEEE forum		
16	News of the IEEE		
	1966 NEREM expected to be largest in 20-year history		16
	Program announced for conference on Engineering in Medicine & Biology		16
	First IEEE Section Chairman Forum held in Los Angeles		18
	Fortescue Fellowships available for 1967-68		19
	Subsection dissolved; new Section, Chapters approved		20
	Machine tools meeting to stress tomorrow's technology		23
	Preliminary plans set for meeting on electron devices		23
	Session topics announced for Fall Computer Conference		24
	R. A. Stampfl receives IEEE Harry Diamond Award		24
	England hosts conference on broadcasting equipment		24
	IGA Group, IEES, AWS announce symposia, movie		26
	Symposium to focus on reliability-cost-performance		26
	Papers invited for Spring Joint Computer Conference		28
	Papers wanted for March photovoltaic specialists meeting		31
	Germany to host meeting on semiconductor device research		31
	IEEE and EIA issue call for electronic components papers		35
	Papers solicited for 1967 Canadian engineers congress		35
	Call for papers issued for communications conference		35
	Call for technical papers issued for 1967 SWIEEEO		36
	IFAC plans meeting on problems of identification		36
39	Calendar		
42	People		
122	IEEE publications		
	Scanning the issues, 122	Advance abstracts, 124	Translated journals, 144
	Special publications, 147		
149	Focal points		
	Video tape and multiprojectors tell story of performing arts at Lincoln Center		149
	Underwater platform proves successful in tests		149
	Computer process enhances Surveyor's pictures of moon		150
	New sound spectrograph prints directly from tape		150
	Ship-to-shore messages are bounced off the moon		151
	High-energy laser uses inorganic fluid		151
	EIA announces new technical documents		152
154	Technical correspondence		
	F. T. Bacon and the fuel cell, <i>H. G. Taylor, C. Gordon Peattie</i>	Correction, <i>M. A. Uman</i>	
	Lavernock radio trials—1897, <i>Rowland F. Poccock</i>	The contourograph and radar display,	
	<i>A. A. Galvin</i>	<i>AC systems stability, A. G. Benedict</i>	
158	Book reviews		
	New Library Books 164	Recent Books 166	

## the cover

The open-wire line strung on insulators along a line of poles was the first transmission system used for long-distance communication by telephone and telegraph. The problems that arise as these systems become more and more complex are analyzed in the group of six articles beginning on page 64.



# Spectral lines

**Optimism and professional ethics.** Some years ago, a professor of mine said, in effect: "I like research on vacuum tubes because people who work on vacuum tubes are optimists, and optimists make such good company. Only the greatest optimists will stay in the field." This is probably the most pessimistic remark I have ever heard a vacuum tube man make, but it is obviously true. So much can go wrong with a vacuum tube that only an optimist would think that one could be made to work.

When this was said, practically the whole of electronics and communications technology was built upon the vacuum tube art, and few would be so pessimistic as to guess that it would not always be so. Alas, today one must look to other branches of engineering to find such optimists. They are not hard to find, however. Now the optimist is proposing to build 40 000 active devices on a chip of silicon, or  $10^9$  memory elements per cubic foot of cyrostat, equivalent to  $4 \times 10^4$  or  $10^9$  vacuum tubes, respectively. Or perhaps he is heterodyning laser beams.

Can anyone doubt that, by some process of selection or election, our ranks are filled with the greatest optimists? Would any but great optimists dare to put a man on the moon, tunnel the English channel, build an atomic bomb, get through engineering college?

Yet, I doubt if optimism is the distinctive feature of the engineer. Are there other characteristics that distinguish him from other optimists; from politicians, gamblers, market analysts, for instance? Surely in the engineer there is a modicum of intellectual proficiency, a lively scepticism, and, sadly, a strain of cynicism (you should see some of our recent correspondence), and an abiding curiosity about how things work. Generalizations are dangerous, but I think most people will agree that curiosity, scepticism, and the desire to build things are most basic characteristics of an engineer.

Another, most distinctive, quality of engineers is perhaps less well recognized. It is an active but reticent idealism, a fine sense of morality and ethics coupled with a respect for privacy of conscience.

Engineers are generally reluctant to discuss morality, ethics, and especially religion, and it is seldom that they find their way into print on these subjects. It is fine that these subjects are not taken lightly, but there are peculiar ethical problems that confront the engineer and for which he sometimes needs guidance. Do we not all too often see misleading contract proposals, innocuous progress reports, exaggerated press releases, extravagant advertisements, and occasionally even plagiarism in technical publications? Do we not sometimes wonder exactly what constitutes a conflict of interests? It is easiest to ignore these things, but they do not just go away. Our reticence is often taken for approbation, and there are many marginal situations that would not occur if acceptable be-

havior were more openly defined.

Fortunately, we have some fine guides for ethical behavior. The Engineers' Council for Professional Development (ECPD) recently published its "Canons of Ethics for Engineers" (33rd annual report for year ending Sept. 30, 1965). There are also a number of fine books on the subject, such as *Ethical Problems of Engineering* by Alger, Christensen, and Olmsted (Wiley, 1965). These may not reform many crooks, but they are of great help in deciding how far one should go in his recruiting practices, contract solicitations, or referencing.

Did you know that the first AIEE code of ethics was drawn up in 1912 by a committee that included Charles P. Steinmetz? Did you know that over 50 engineering groups have subscribed to the ECPD "Canons of Ethics." Did you know that some people believe that the phenomenal success of science and engineering in recent history stems from large-scale cooperation that is possible only in a society with strong professional ethics?

The Alger book makes a very strong statement:

"... professional ethics, as practiced by the vast majority of engineers, makes possible professional group activity and binds the profession together. It is not only one of the foundation stones upon which our American society rests, but one of the primary reasons why our country stands like a giant among the nations of the world."

How happy we can be that the days when personal art and secret process were prevalent have passed and that most engineers are willing, yes, even anxious, to share their knowledge. With the great rush to publish, there is little danger that any important scientific knowledge will be lost to civilization, but it was not always so.

Of course, there now are many safeguards that protect the individual from loss of credit; for instance, the patent system, and means for widespread and rapid publication. However, even these could not have developed without a strong base of professional ethics.

The book also points out that: "Professional ethics must be based upon personal ethics and ideals."

It seems to me that one of the factors that make engineering an attractive profession is the personal character of engineers—their intellectual curiosity, optimism, idealism. Curiosity and optimism show in nearly every undertaking. Idealism shows in the freer cooperation that is evident in almost every engineering project. It also shows in the engineer's civic activity, in statements on public issues, but only occasionally in statements on ethical and moral issues or religious and philosophical matters. Recently, however, two prominent Fellows of this Institute published articles on the relation of science and religion. It is good that some of us have the courage to speak out. Why not have more? C. C. Cutler

# Authors

Compatibility—A challenge to universal communications (page 64)



**T. B. Westfall**, executive vice president of ITT, is responsible for the direction, coordination, and expansion of ITT's telephone and international telecommunications operations and domestic telephone manufacturing. He received the B.S. degree from the University of Oklahoma and the L.L.B. degree from George Washington University and, before joining ITT in 1960, had been with Price Waterhouse, U.S. Government General Accounting Office, and Grace Lines.



**Lowell F. Wingert**, vice president of the AT&T Long Lines Department, has been associated with the Bell System since 1934, when he joined what is now the North-western Bell Telephone Company. Prior to his present position he had been vice president of operations, Pacific Telephone & Telegraph. He is also director of Cuban American Telephone & Telegraph, Transoceanic Cable Ship Company, Transoceanic Communications, and Transpacific Communications.



**Marc Lambiotte**, director general of the Belgian Telephone & Telegraph Administration, has been with the Administration since 1935, mainly as a specialist in the field of studies, building, and maintenance of central office installations. He graduated from the University of Louvain as an electrical and a civil mine engineer and was with the Union Minere de Haut Katanga for four years. He presently chairs the CCITT Semiautomatic and Automatic Networks Committee.

**R. H. Franklin** (photograph unavailable at time of publication) received the B.Sc. degree from London University. After joining the British Post Office in 1924, his work consisted of specifications for automatic telephone exchanges, submarine cable design and maintenance, and development of transmission systems. In 1939 he was stationed at St. Malo as liaison officer with the French War Office; later, he directed the laying of cables from Cairo to Haifa-Beirut and Alexandria-Alamein. Then, after supervising planning of main and local lines for the British Post Office, he was loaned to the Air Ministry as deputy director of signals and subsequently to the Royal Canadian Air Force as a member of the communications committee. He returned to the Post Office in 1953 to aid in the development and maintenance of the transatlantic telephone cables and the British Commonwealth system of cables.

**Asher H. Ende**, deputy chief of the FCC Common Carrier Bureau, received the B.A. degree from Brooklyn College, L.L.B. degree from Brooklyn Law School, and M.B.A. degree from New York University. He has been with the FCC for 19 years in capacities such as chief, Office of Satellite Communications; hearing examiner; and chief, Rates and Revenue Requirements, and has chaired delegations to international meetings since 1951. He has received the FCC's highest award.



**James H. Weiner (M)**, Brigadier General, is chief of staff of the U.S. Defense Communications Agency, which provides overall management and operations supervision of the worldwide defense communications system. During World War II, he received the Legion of Merit for setting up communications and flight facilities to ferry aircraft from the United States to the African theater. Later, he directed plans consolidating communications facilities of the Pacific Air Forces area.



### The future of energy supply (page 82)

**B. C. Hicks** (SM) received the B.S.E.E. degree from McGill University in 1927. From then until he retired in 1966, he was associated with the electric utility industry, with the Shawinigan Water & Power Company and its successor, the Quebec Hydro Electric Commission. First assigned to the Protection Department, he soon became superintendent of protection; later, as consulting engineer, he analyzed broader aspects of electric utilities. He has advocated the optimum development of tidal power in the Bay of Fundy and suggested a causeway dam across the lower bay to provide a highway from Nova Scotia to the mainland and to develop more than 50 000 MW of tidal power.



### Industrial radio telemetry (page 89)



**C. H. Hoepfner** (F), president, Industrial Electronics Corporation, Melbourne, Fla., received the B.S., M.S., and E.E. degrees from the University of Wisconsin. Associated with various companies during his career, he participated in pioneer work in telemetry research and development and has assisted in developing PCM/FM techniques, a major breakthrough in the field. He has also contributed to the development of FM/FM commercial telemetry systems, television, remote control systems, guided missiles, various digital devices, and radar beacons. He has engaged in and supervised work on electronic countermeasures, radar development, missile instrumentation and guidance systems, digital data processing systems, digital transducers, and RF equipment.

### Prime-mover response and system dynamic performance (page 106)

**C. Concordia** (F), consulting engineer, Electric Utility Engineering Operation, has been with the General Electric Company since 1926. His work has been mainly concerned with the dynamic analysis of electric machinery, interconnected power systems, and automatic control systems, including power system voltage, speed, tie-line power, and frequency control. He has been particularly active in the application of analog and digital computers in the solution of these and other engineering problems. In 1942, he received GE's Coffin Award for contributions to the analysis of wind-tunnel electric drives and, in 1962, AIEE's Lamme Medal for achievements in electric machinery development.



**F. P. deMello** (SM), senior application engineer in General Electric Company's Electric Utility Engineering Operation, received the B.S. and M.S. degrees from M.I.T. in 1948 and then spent seven years in system planning and engineering studies for a large utility in Brazil prior to joining the GE Analytical Engineering Operation in 1955. For the past several years, he has been working in the area of utility power plant and power system controls, and he has been responsible for extensive General Electric research and development efforts in analog and digital simulation of boiler-turbine dynamics and design of integrated multivariable plant control systems. His work on dynamics and control of power systems has also included analog and digital computer modeling of electric machinery—their excitation controls and governor controls.



**L. K. Kirchmayer** (F), manager, General Electric System Planning and Control Section, received the B.S. degree from Marquette University and the M.S. and Ph.D. degrees from the University of Wisconsin. After serving with Cutler-Hammer and the University of Wisconsin, he joined the GE Analytical Engineering Section in 1948 and was given assignments in the field of system analysis. He served as manager of power systems operational investigations and, later, system generation analytical engineering. In his present position he is responsible for the development of advanced concepts of electric utility planning, operation, and control with respect to characteristics, requirements, and conditions affecting systems and product designs, and he directs investigations of computer control, circuit analysis, economic modeling, and mathematical programming.



**R. P. Schulz** (M) is presently an application engineer in the System Planning and Control Section of General Electric Company's Electric Utility Engineering Operation. Enrolled in the power-oriented combined curriculum at Lehigh University, he received the B.S.M.E. degree in 1958 and the B.S.E.E. degree in 1959; in 1966 he received the M.S.E.E. degree from Union College. He joined General Electric's advanced engineering program in 1959 and, since 1962, he has been with the Electric Utility Engineering Operation as an application engineer in the System Planning and Control Section. He is currently working on computer simulation of electric power generation dynamics. In particular, he has been studying effects of generator excitation and turbine-governor systems on reduction of power system overvoltages and on power system stability.





**The philosophy of engineering (page 112)**

**Henry Greber (SM)** received the M.S. degree in electrical power engineering from the German Technical University in Brunn, Germany, and another M.S. degree from the Polish Technical University in Lvov, Poland. The wide range of his experience in the area of power engineering includes operation and design of electrical power plants and transmission and distribution facilities as well as research.

Mr. Greber is the author of numerous published papers and articles and holds seven U.S. patents. Two of his papers and two of the patents are concerned with the topic of electrical fuses; other papers and patents deal with various problems encountered in the transmission and distribution of electric energy. A large part of his research effort has been concentrated on the fields of transmission and distribution and the reliability of electric energy supply systems. He is an associate member of the Institution of Engineers, Australia, and a licensed professional engineer in the state of New York.

**Real-time digital analysis system for biological data (page 116)**

**J. Ryland Mundie** received the B.S. degree from Ouachita Baptist University in 1951 and the M.D. degree from the University of Arkansas School of Medicine in 1956. During medical training he became interested in neurophysiology and worked as an assistant in research, correlating the development of the neurochemistry and electrophysiology of immature nervous systems. After internship, Dr. Mundie entered the U.S. Air Force and attended the School of Aviation Medicine. He was assigned as a flight surgeon to the research activities of the Neurophysiology unit of the Aerospace Medical Research Laboratories at Wright-Patterson Air Force Base, where he engaged in research on the mechanical characteristics of the ear and the physiology of hearing. Since 1959, he has been with the laboratories as a civilian. At the present time, he is chief of the Neurophysiology Branch of the Biodynamics and Bionics Division, conducting research on functional and mathematical descriptions of the nervous system.



**H. L. Oestreicher (SM)**, chief of the Mathematics and Analysis Branch of the Biodynamics and Bionics Division of the Aerospace Medical Research Laboratories at Wright-Patterson Air Force Base, received the Ph.D. degree in mathematics in 1934 from the University of Vienna, Austria, and later received an advanced degree in physics from the same institution. He remained with the University of Vienna, as a research assistant and lecturer, until 1943 when he became associated with the Helmholtz Institute, Landsberg, Bavaria. At Helmholtz Institute, he served first as a research mathematician and later as chief of the Applied Mathematics Branch.

In 1947, he came to the United States and joined the Wright-Patterson Aerospace Medical Research Laboratories, where he now heads the Mathematics and Analysis Branch of the Biodynamics and Bionics Division. The areas of research with which he has been concerned include mathematics, theoretical biophysics, bionics, acoustics, and wave propagation theory.



**H. E. Von Gierke** received the Diplom Ingenieur in 1943 and the Doctor Ingenieur degree in 1944 from the University of Karlsruhe, Germany. He served as a research assistant at the university's Institute for Theoretical Electrical Engineering and Communications Technique, working on several projects in the fields of acoustics and applied physics, and later lectured on high-frequency communications techniques. Since 1947 he has been engaged in research in the fields of physical and physiological acoustics, aviation acoustics, biodynamics, and biophysics for the U.S. Air Force; he is now chief of the Biodynamics and Bionics Division of the Aerospace Medical Research Laboratories at Wright-Patterson. The division is performing research in all areas related to the effects of noise, vibration, and impact on man to provide principles for protection against such hazardous biodynamic environments, and research in bionics, cybernetics, and neurophysiology. He has received awards from the Aerospace Education Foundation, the Wright Air Development Division, and the Department of Defense.



# IEEE launches program for new and expanded services

*The Board of Directors has approved support for a new continuing education program and for new information services. A feature of the new plan is a support system that rewards increased participation at the Section and Group levels*

*William G. Shepherd*    *President IEEE*

In the June announcement of the decision of the Board of Directors to increase the membership dues of the Institute, the members were asked to offer suggestions to the Board that would guide them in decisions with respect to the future course of the Institute. The majority of the responses recognized the circumstances that had led to the decision that a dues increase was imperative if the Institute is to continue as a vital force in our profession, and they offered helpful suggestions. Many, however, expressed dismay at the increase and were critical of the services provided to the membership since the merger. Both responses provided meaningful guides to the Directors in reaching their decisions on the deployment of resources resulting from the increase.

In recommending a dues increase, the Executive Committee of the IEEE has gone through a reassessment. It has studied over a long period, and in depth, the health of the Institute and the kinds of objectives it should pursue in the future to provide both the best short-term and best long-term gains for its membership.

For some time it had been evident that a dues increase would be necessary. The combination of our reduced income and the broadening technical interests of our members made the decision more one of timing the increase than of deciding that one was needed.

Over a period of time, we had been drawing on our financial reserves, reducing them below what prudent management would regard as a desirable level. I need only add to what was said in the June issue of IEEE SPECTRUM that more than half of the income from the dues increase must be allocated to balance our current budget, to replenish our reserves in an orderly way, and to take care of contingencies. The balance, less than half of the income derived from the dues increase, or roughly \$600 000, now permits the Institute to meet the expressed needs of the members for new and expanded services. This program on which the Institute is embarking has been made directly possible through the dues increase.

What these new services should be and how they should be implemented from the Institute's operating budget have been the subject of intensive study for almost two years by the Executive Committee and two special task forces. During this process, many plans and proposals have been put forward. Also, this summer the members and organizational units of the Institute were asked to provide their own recommendations. Balancing

these expressed needs with the funds available, the Executive Committee and Board have now adopted a plan that provides, in my judgment, substantial benefits to every Institute member. In addition, it offers incentives for increased participation in our many activities and publications—to the members' direct benefit and to the benefit of the Institute and our technology. The elements of this participation support are described in more detail later in my discussion.

## **Features of the new plan**

Some of the features of this plan were developed in the studies made in 1965. These were included in the tentative proposals made to the Board of Directors in March of this year. Since that time, these and other proposals have been aired at all levels of the Institute organization—letters from individual members, from Sections, from standing committees, etc. The approved plan resulting from this collective judgment has the following objectives:

- To provide a balanced and equitable service to all segments of the Institute membership
- To insure that the Institute moves ahead in keeping with the expanding technology and broadened fields of member interest
- To respond to the outstanding expressions of need from every level of the membership
- To strengthen the role of the Sections as the source of the grass roots governance of the Institute
- To strengthen one of our basic concepts of the Institute as a cohesive federation of Groups
- To improve the quality of the Institute publications and thus increase their value to the membership
- To bring members greater opportunities to participate at the local Group Chapter level

The major features of the new plan that attempt to satisfy these objectives are as follows:

- Increased support of IEEE SPECTRUM to make it more valuable to members (more feature pages, but primarily an enlargement of the editorial staff to strengthen the staff's editorial capability)
- New support for continuing education programs
- Increased support for Region, Section, and Group Chapter activities (including special allowances that encourage the formation of new Chapters)
- Increased support of the general publications of the Institute—editorial improvement and expansion

## I. Allocation of new income under program recommended by IEEE Board of Directors

The approximate allocation planned by the Board of Directors from the funds that will be obtained from the \$10 increase in the membership dues and the upward repricing of the nonmember subscriptions is detailed below.

Purpose	Approximate Amount	Percentage
<b>Publications:</b>		
Increased support of IEEE SPECTRUM	\$ 38 000	3.2
Increased editorial support of PROCEEDINGS OF THE IEEE	75 000	6.2
Reduction of PROCEEDINGS subscription price (Member price reduced from \$6 to \$3, reducing net subscription income by \$112 000)	112 000	9.3
<b>Information services</b>	45 000	3.8
<b>Groups</b>		
Additional support of TRANSACTIONS publications	165 000	13.7
<b>Continuing education program</b>	45 000	3.8
<b>Additional support of IEEE Directory</b>		
To permit price reduction: \$50 000 every two years	25 000	2.1
<b>Regions, Sections, Chapters</b>		
Additional services for members in Regions 8, 9, and 10	25 000	2.1
Additional rebates to Sections, including Group Chapter membership rebate	70 000	5.8
<b>Elimination of operating deficit</b>	200 000	16.7
<b>Replenishment of reserves, contingencies, etc.</b>	400 000	33.3
<b>Total</b>	<b>\$1 200 000</b>	<b>100.0</b>

Fig. 1. Comparison of 1966 and 1967 budgets

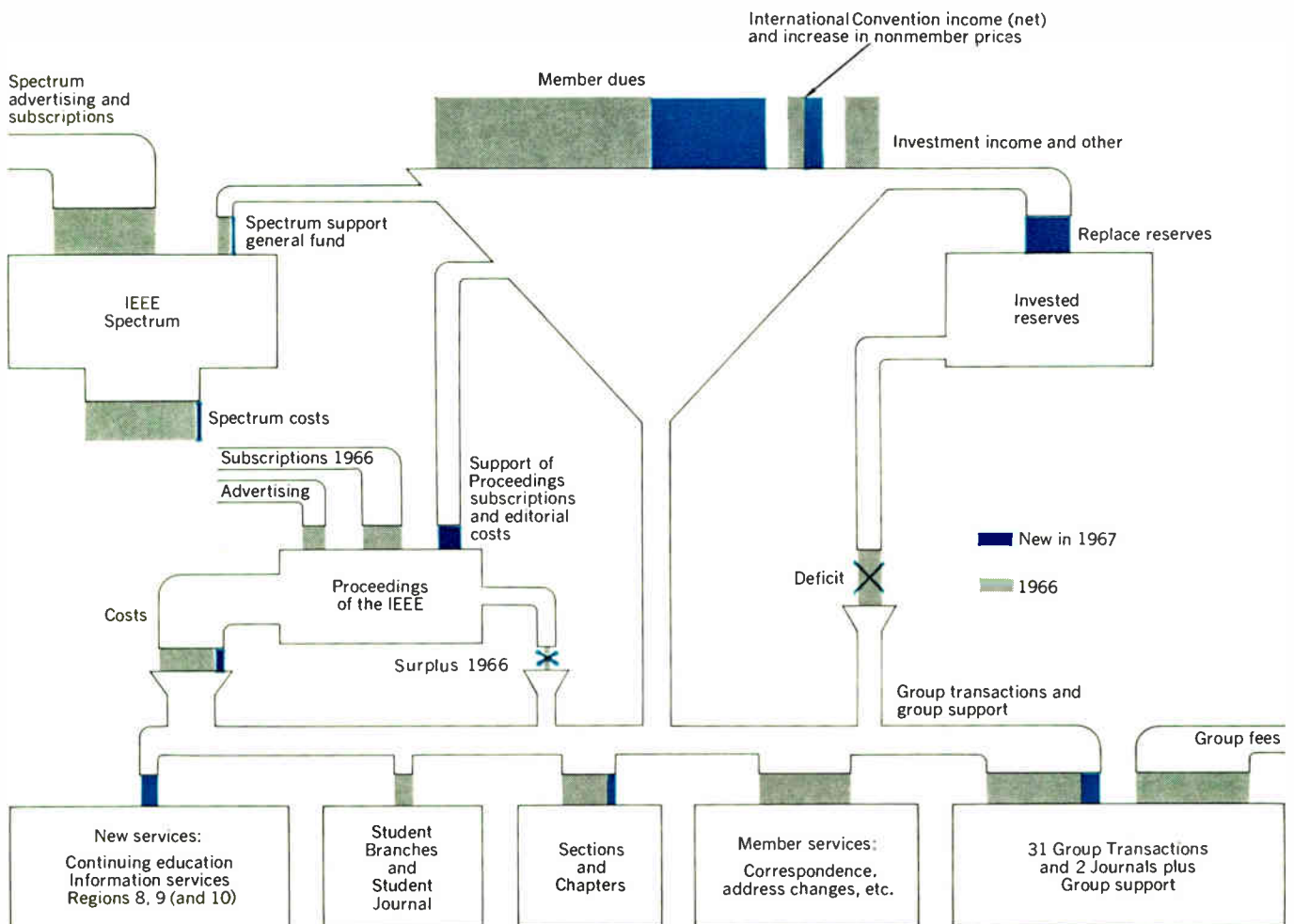



## II. Comparison of 1966 and tentative 1967 budget, showing the effect of the dues increase

	1966 Budget		1967 Budget (Tentative)		
	Total Costs (000 omitted)	Cost per Member*	Proposed New Expenditures (000 omitted)	Total Anticipated Expenditures (000 omitted)	Total Cost per Member*
<b>Expenditures</b>					
<b>Publications</b>					
SPECTRUM	\$ 90	\$ 0.72	Additional pages and staff	\$ 38	\$ 1.10
PROCEEDINGS	(51) (income)	(0.41)	Additional pages and staff	75	1.16
			Reduction of price to \$3	112	
STUDENT JOURNAL	73	0.58		73	0.62
Other publications	16	0.13	Directory support to reduce price	25	0.35
			Increased pages and support	165	
Group TRANSACTIONS (less nonmember sales)	385	3.08†	Less increased price— nonmember	(150)	3.42†
	\$ 513	\$ 4.10		\$ 265	\$ 6.65
Group activities (exclusive of Group TRANSACTIONS)	\$ 482	\$ 3.86†		\$ 482	\$ 4.12†
Support of Sections	378	3.02	Changing of rebate, etc.	\$ 70	3.83
Student activities (less Student dues)	84	0.68		84	0.72
General membership	813	6.50		813	6.95
Other professional societies (EJC, ECPD, etc.) and libraries	131	1.05		131	1.12
Other	139	1.11		139	1.19
Continuing education				45	0.38
Information retrieval				45	0.38
Regions 8, 9, and 10 assistance				25	0.21
				\$2990	\$25.55
Replacement of reserves used in prior years, contingencies, etc.				400	\$ 3.42
	\$2540	\$20.32		\$ 400	\$ 3.42
				\$3390	\$28.97
<b>Less other income</b>					
International Convention	\$ 175	\$ 1.40		\$ 175	\$ 1.49
Investment income	235	1.88		235	2.01
Other	55	0.44		55	0.47
Operating loss— reduction of reserves	200	1.60	Elimination of deficit	200	0
	\$ 665	\$ 5.32		\$ 465	\$ 3.97
<b>Membership dues</b>	<b>\$1875</b>	<b>\$15.00</b>		<b>\$1050</b>	<b>\$25.00</b>

\* Estimated membership excluding Life, Student, and Affiliate members

† The support of Groups totals \$6.94 in 1966 and \$7.54 in 1967 after giving credit for nonmember sales

- Enhancement of the immediate and archival value of the TRANSACTIONS of the IEEE by providing support sufficient to insure the careful editing and prompt publication of all significant contributions
- Increased support for the PROCEEDINGS OF THE IEEE as a basic journal that provides an overview of the advances in the field both for the generalist and for the specialist who wishes to keep abreast of activities outside of his specialty. This recognizes the generalists as an overall group and brings the support for this publication more in line with that provided for the TRANSACTIONS

- New support of information services to cover preliminary studies to make IEEE publications adaptable for information retrieval and to design systems compatible with other retrieval systems being devised
- Support for the Directory (a price reduction)

The approximate allocations for each of these categories are detailed in Table I, which also shows the percentage that each represents of the total \$10 dues increase. Table II lists a comparison of the 1966 and tentative 1967 budgets, showing the effects of the dues increase.

For those who are graphically minded, Fig. 1 shows

somewhat qualitatively how the Institute has been managing its activities; it indicates also, in color, the changes that will be effected under the new plan. Very briefly, this illustration shows the major sources of our income—dues, International Convention, investments—in proportion. Likewise, it shows what share of this income goes into the invested reserves, the shares that go into the various activities of the Sections and Chapters, to the TRANSACTIONS, and so on. It reveals, among other things, that IEEE SPECTRUM has been just about self-supporting (the per-member cost has been only about 71 cents a year), that the PROCEEDINGS has been returning money to the Institute (about \$50 000 a year), and that the TRANSACTIONS have been heavily supported (i.e., in most cases, the TRANSACTIONS could not go it alone). Furthermore, Fig. 1 illustrates just how the support of our Group publications, Sections, Chapters, Student Branches, and so on, has been drawing on our invested reserves.

The impact of the increased income from dues, and the restructuring of our program of support throughout all Institute activities resulting from our plan for new and expanded services, appear in color. With our budget balanced, the drain on our invested reserves will stop and the depleted reserves will be gradually replenished. To a degree, PROCEEDINGS will start getting the same type of support as the TRANSACTIONS. The support to IEEE SPECTRUM will be increased slightly. There will be a strong allocation to new services—continuing education programs and information retrieval studies—and a significant increase of support to the important TRANSACTIONS and JOURNALS, and to the Sections and Group Chapters.

The evolution of new services and the increased assistance to Section, Group Chapter, and Group activities are, I feel, the most significant factors in the plan. The increased support for the Group TRANSACTIONS may be regarded as an effective built-in participation benefit. I shall say more about this later.

#### **Background—the problems and the needs**

I believe it would be worthwhile to review some of the problems that led to the plan that was ultimately adopted.

It is hardly possible, of course, to convey to the individual members, whose contacts with the Institute may be either very specialized or very tenuous, all of the factors that went into our analysis and thinking. However, I do believe it is important that each member get some of the “flavor” of this study that has now extended over a period of more than a year so that he may grasp the true nature of the balance we have struck in our allocations.

First of all, this plan for new and expanded services is a direct consequence of the expressions of concern and need from the members themselves, from all segments and levels of the membership, including those in positions of leadership. What did the members tell us they wanted? What did they feel they needed? Who were these members? How did their requests and needs balance out with the needs and requirements of the whole Institute? Who was getting a fair and appropriate share of Institute resources and who was not?

From all levels of our membership, there appeared three or four outstanding expressions of desire for additional support. Many of the Group members felt that they should get one Group membership, or some fraction

of it, included in basic dues. Group members, it should be said, constitute about 40 percent of our total members. Another large segment of our membership, the subscribers to the PROCEEDINGS, noted that they now pay \$6 extra for the PROCEEDINGS whereas in the past they had received it with their basic membership dues. Since only about 40 percent of the 38 000 members subscribing to PROCEEDINGS are members of Groups, one might regard them as a type of group having particularly broad interests. A third segment of our membership was concerned that it now has to pay \$8 for the membership Directory, which formerly had been free. Still another segment of the membership voiced the feeling that the Sections were in need of greater Institute support.

All members of the IEEE, of course, receive SPECTRUM, the core publication. For the half of our membership who are not Group members, those who work as generalists or in broad administrative positions, SPECTRUM is one of the major sources for keeping in touch with the broad developments in our ongoing technology. How well is this more diffuse segment of our membership being served? We had developed some ideas about this from our correspondence and from our many discussions with members on all occasions. The feeling was mixed; however, there is no doubt in our minds that this publication can be improved and made a more valuable part of each member's technical resources.

In addition to these specific questions, there are the general problems that all our members must confront in their professional lives, and with which they look to the Institute for assistance—the pressing need for continuing education in view of the rapid advance of technical developments, and the oppressive weight of the information revolution itself that bears on every aspect of the practicing engineer's life.

These are but some of the expressed desires and requirements that the Board of Directors had to take into account in selecting a course of future action.

There were, moreover, some factors that arose during the analysis of our operations that were particularly enlightening. We discovered that although we were following reasonable accounting procedures, our methods did not reveal the fully allocated costs of our various services. We had been keeping an account of our costs and our income by *functions* rather than by *services*. For instance, publishing is a function of the Institute operations, but it covers many specific publications, notably the TRANSACTIONS, the PROCEEDINGS, and SPECTRUM. Yet, each publication has a unique value in the service it provides each member. It became important, we realized, to get a measure of actual costs for each of these particular services. The emergence of this cost vs. service concept rather than cost vs. function concept has become an important general guide in caring for the needs of our members.

#### **Earlier plans—pros and cons**

At one stage along the way, most of us were in favor of what we called the participation credit plan. In effect, this plan established a credit of approximately \$3 applicable to either the first Group membership fee, the PROCEEDINGS subscription, or the Directory, as the individual member preferred. However, as we studied this plan, we saw that its implementation, its cost in terms of reduced income rather than increased services, would

have tied our hands with respect to the need to provide improved services. It would have drained away the money needed, after taking care of our deficit and reserves, to push the Institute forward. It would have become a standstill plan rather than a move-ahead plan. This seemed neither fair to the membership nor what we believed they really wanted.

Then, too, we had to weigh the conflicting pressures for new services and increased support. A number of TRANSACTIONS were being published less frequently than desirable whereas others had backlogs of worthy articles. This situation suggested the need for more support. PROCEEDINGS subscribers and advertisers were pumping a larger share of money back into the Institute than was being expended on its publication. Was this fair to them? TRANSACTIONS already had heavy support, but was it enough? Was SPECTRUM doing all it could to serve the members who depended on it? How were we to take into account growing inflationary pressures? Were we doing enough for members outside the United States and Canada, those in Regions 8, 9, and 10? It was clear that our greatest responsibility lay in making our judgments about these conflicting pressures in light of the long-range problems and objectives of the Institute as a whole.

It was this thinking that led us to the plan we finally crystallized, which embodies most of the attractions of the participation credit plan, but which allows the Institute to make the most fruitful use of our increased income. We effected a kind of built-in participation support in which the real capital of the IEEE—its capacity to advance the very technology upon which each member is dependent—is allowed to mature and to act for the benefit of us all.

#### **Built-in participation benefit**

As I mentioned earlier, one of the problems on which our Executive Committee spent much effort was the relation of costs to individual services. We needed to do this in order to find out precisely what these services were costing so that we could effectively weigh their values to the members.

For example, in the case of the Institute's technical activities as carried out by the Groups, it became clear that the Institute now provides support to the TRANSACTIONS, conferences, standards, etc., amounting to \$6.94 per full-paying member (in 1966); see Table II. Under the new plan, this support will be increased even further, to \$7.54 per full-paying member. This strong support is what we regard as the built-in participation benefit for the member joining a Group.

Another way in which active participation brings a better bargain for members is in our increased support for Section activities. This will come in the form of additional rebates to Sections, including Group Chapter membership rebates, amounting to about \$70 000. The Group Chapter membership allowance will encourage the formation of new Chapters in the Sections and improve the viability of the present Chapters. Every Section will get an allowance contingent on the existence of the Group Chapter in the Section and proportional to the number of members of the Group within the Section. Thus, both the Group and Section members get improved services at the local level, through meetings and local publications.

#### **Continuing education**

A totally new support that is going to the Section level, and which again rewards local participation, is the allocation of \$45 000 for continuing education programs. Thus, many individual members will be able to derive the benefits of a wide range of refresher and updating courses managed at the Section level. From all accounts, these programs should prove extremely popular and the Institute intends to strengthen their thrust and diversity.

#### **Regions 8, 9, and 10**

Additional support is being provided for Regions 8, 9, and 10, all those regions outside of the United States and Canada, to the extent of about \$25 000. Many of our members in these regions are not able to take full advantage of Institute activities. For this reason we must provide more support for the services that primarily interest them.

#### **Toward stronger Transactions**

For those who are not sure of the value to themselves of increasing the quality of the TRANSACTIONS, the two new JOURNALS, and the PROCEEDINGS, we urge that they consider both their direct and indirect usefulness. Largely archival, these publications are the storehouse of our technology. Perhaps many of us have not stopped to think how tremendously we benefit from the technological expansion reported in these archival journals. It is the sum total of these reported advances that provides the foundation for current practice. It has been estimated that the TRANSACTIONS constitute 10 percent of the primary electrical engineering literature produced in the entire world.

There are some people who will retort, of course, that they can get along without the TRANSACTIONS, that they get what they need in various trade journals in existence, many of which come to them free. These are, of course, valuable, but they derive much of their value from the archival creative literature as represented by the TRANSACTIONS and the PROCEEDINGS. Even most textbooks, another form of the rewritten technology, draw heavily upon the primary technical sources. We believe that it is most appropriate that the Institute provide the strongest possible support for the primary journals—for, in our judgment, this archival literature constitutes one of the great contributions that the Institute can make through its active, creative members.

#### **Conclusions**

By their very nature, budgets and budgetary allocations are for most people both impersonal and perhaps even arbitrary. But to anyone who must work closely in their construction, this is hardly the case. He is concerned with the ultimate effects of the budget on the health of the organization involved. For him it represents a system of balances and trade-offs in which each interlocking element is hard won. This new proposed financial plan, with its program for eliminating our deficit, replenishing reserves, and establishing new and expanded services, truly benefits every member. It does so in some very special ways. It answers real needs and it aims particularly at the long-range strength and objectives of the Institute—the technical well-being of its members and their successors and the vigorous growth of the fields in which they work.

# Compatibility—A challenge to universal communications

*A requisite for mutual understanding, whether between persons or between nations, is the ability to communicate. However, the achievement of effective global communications depends on the solution of various problems; notably technical compatibility*

The prognosis for worldwide communications is discussed from six viewpoints. A look at the future roles of satellites and submarine cables, an evaluation of the advances in international telephone routing, and a CCITT progress report are presented. The technical and economic tasks necessary to achieve compatibility

are outlined, and Comsat's organizational structure, and its relationship to international communications, is appraised. Finally, the military communications networks in support of U.S. international and United Nations commitments are described, with reference to possible interconnections with commercial systems.



## Global cables and satellite communication

*T. B. Westfall*    *International Telephone and Telegraph Corporation*

Global communication is a prime vehicle for peace, understanding, and trade; and engineers can be proud that through their work they can participate in winning the war against prejudice and suspicion. Mass communication and mass transportation are the great forces that are reducing the barriers to international understanding.

In international communications the improvement has been such that instead of the terse, abbreviated messages of the old-style telegram, which provided the basis for endless misunderstandings, present communication by telegraph methods is carried out in the same form as well-written letters, and the amount of information exchanged in this way is increasing at a tremendous rate. As for international telephone circuits, the rate of growth

seems to depend mainly on the availability of fast service of high quality, plus, of course, the needs of trade, business, tourism, and transportation between the countries involved.

Satellite communication has recently added worldwide television to the scene, and telephone submarine cables are providing high-quality service. The dramatic transmission by satellite television of the recovery in the ocean of the spaceships and astronauts of the Gemini missions showed the potential of satellite television transmission. In any part of the world covered by the synchronous satellite, a mobile station carried by a ship at sea, or installed in a few hours on land, can transmit events of world interest.

Consider the great progress that has been made since the first transatlantic radiotelephone (one channel) was inaugurated in 1927 between England and the United States, through the pioneering efforts of the British Post Office, AT&T, and ITT. Just 40 years ago who

Essential texts of papers presented at the Keynote Panel Session of the IEEE International Communications Conference, Philadelphia, Pa., June 15, 1966.

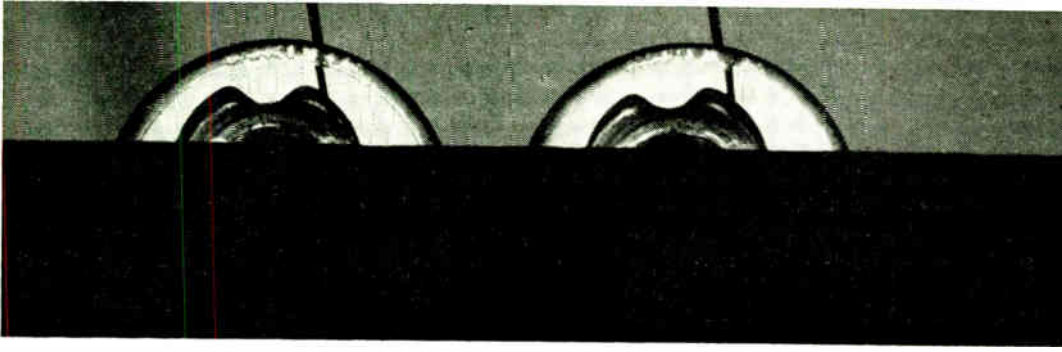

would have imagined that a Mariner spaceship could send radio signals across 80 million miles and that close-up photographs of Mars could be sent to the earth by digital transmission, using the principle of pulse code modulation?

Today, submarine cable and satellite communications are dominating global communications and I will briefly describe the progress achieved. However, first let us examine the expected progress of national communications, which form the base on which global communication will grow.

Already huge by any measure, the telecommunication industry will grow more than five times in the next 35 years. Today there are about 195 million telephones in the world, gross plant investment of telephone companies and administrations is estimated at from \$75 billion to \$100 billion, and the telephone organizations alone employ more than two million persons. By the year 2000, the number of telephones will have grown to over one billion, investments will have increased to \$500 billion, and employees will have jumped to more than 10 million.

The rate of growth will be faster in Europe and the rest of the world than it will be in the United States. The United States now has 48 percent of the world's total, with 94 million telephones, and will reach 300 million, which is 25 percent of that total; Europe now has about 31 percent, with almost 62 million instruments, and will reach 500 million, or 42 percent. The rest of the world accounts for the remaining 21 percent, with 40 million telephones, and will reach 33 percent, with 400 million telephones.

This predicted growth means that the number of telephones in the world will increase to 1200 million by the year 2000. It also means that many telephone terminals will have additional functions in the future; for example, as data terminals, print terminals, or phone vision stations. To illustrate the magnitude of the problem in that year, we can show that if half the world's telephone users could dial each other directly, the worldwide telephone networks would have to be able to make  $12.5 \times 10^{15}$  different connections in seconds. More than the assembly of hardware is involved, however. There are other requirements:

1. A worldwide numbering system, giving every main telephone and extension a discrete number of no more than 12 digits so that it can be reached by dialing (or pulsing) from any other telephone.

2. A worldwide complex of switching centers with great capabilities. When a telephone number is dialed or pulsed anywhere in the world, it should be routed effi-

ciently—around sections congested with traffic or in trouble—to its destination.

3. A coordinated set of signals, and the methods of generating and translating them, so that the switches will know what to do and how to do it.

4. A coordinated transmission plan, so that people can effectively talk after a connection has been set up.

5. Automatic methods of accounting.

6. Coordination of operating, maintenance, commercial, and other functions.

7. New equipment: fast switches and signaling systems, high-velocity four-wire transmission facilities, very flexible common controls in switching systems, and equipment that can handle bands of various widths.

8. International telephone service to people on the move, in airplanes, trains, ships, automobiles.

9. Faster connections, in a matter of seconds.

In addition, broadcasting and television will become more and more global, as will transmission of facsimile data.

All this has been made possible by both submarine cables and satellite systems. And as is often the case when a well-established solution is challenged by a new one, the competition has resulted in progress on all sides.

Cables now under development will have a capacity of 640 or 720 channels, and capacities of up to 1200 channels are visualized. This is the answer of the cable systems to the threat posed by the satellites. The added capacity will cut costs substantially; in a reasonable future, isotope power may be available at each repeater. It is quite clear that cables will continue to expand along a number of advantageous trunk routes. In the meantime, the present cables remain competitive on short- and medium-distance trunk routes. We also know that two necessary links of synchronous satellites cause an excessive delay in transmission, and so have recommended that conversations that must extend over the world, on more than one synchronous satellite link, be continued (or started) with a submarine cable link.

The success of the synchronous satellites has been most heartening for those of us who suggested their use very early. One can easily predict that the bandwidth available will become very large, and that television and many telephone channels will become available in all countries of the world covered by the satellite. The satellite is so well adapted to this wide intercommunication between the nations covered that multiple access, with a minimum of lost bandwidth, is a necessity. There is absolutely no reason why it cannot be achieved.

All this fantastic development of the last decade permits us to envision the future, as graphically illustrated

in Figs. 1-3. Figure 1 compares existing, planned, and projected international voice channels. The intercontinental communications channel requirements and revenue distribution for the period 1970-1980 are shown in Fig. 2, and the present and predicted submarine cable networks (telephone transmission quality) are charted on the map of Fig. 3.

The routine of traffic between satellites and cables and the tariffs to be decided upon will require clear and practical thinking. I am sure that the administrations involved will deal with this problem in a way that will take full advantage of the availability of the two systems,

including the suggestion to avoid two satellite links in tandem.

The multiple access and the distribution of channels available from the satellites in the countries involved raise many technical problems of switching and distribution, which will be solved—but only through international cooperation. The horizons opened by the astounding progress in global communications lead us to believe that we will win the race for peace, understanding, and trade and against suspicion and hatred, which are based only on lack of true knowledge and communications.

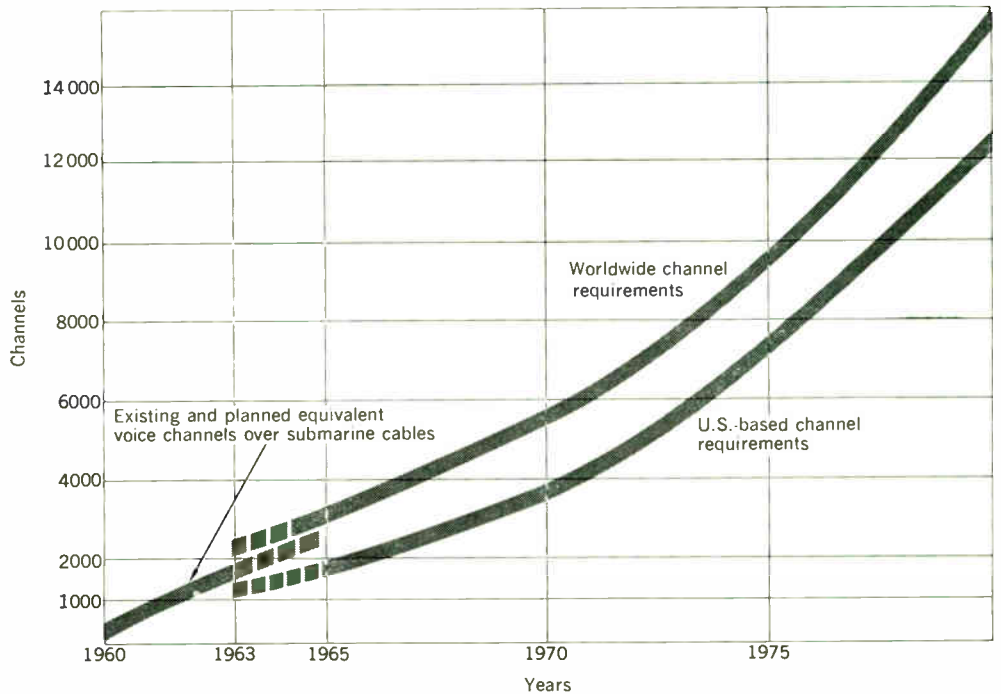
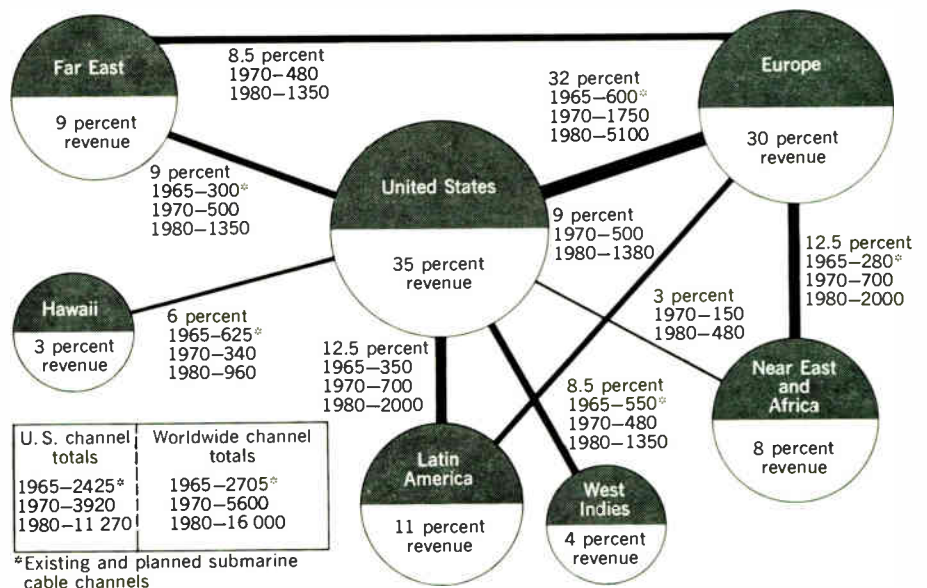

Fig. 1. Existing, planned, and projected international voice channels.

Fig. 2. Intercontinental communications channel requirements and revenue distribution, 1970-1980.



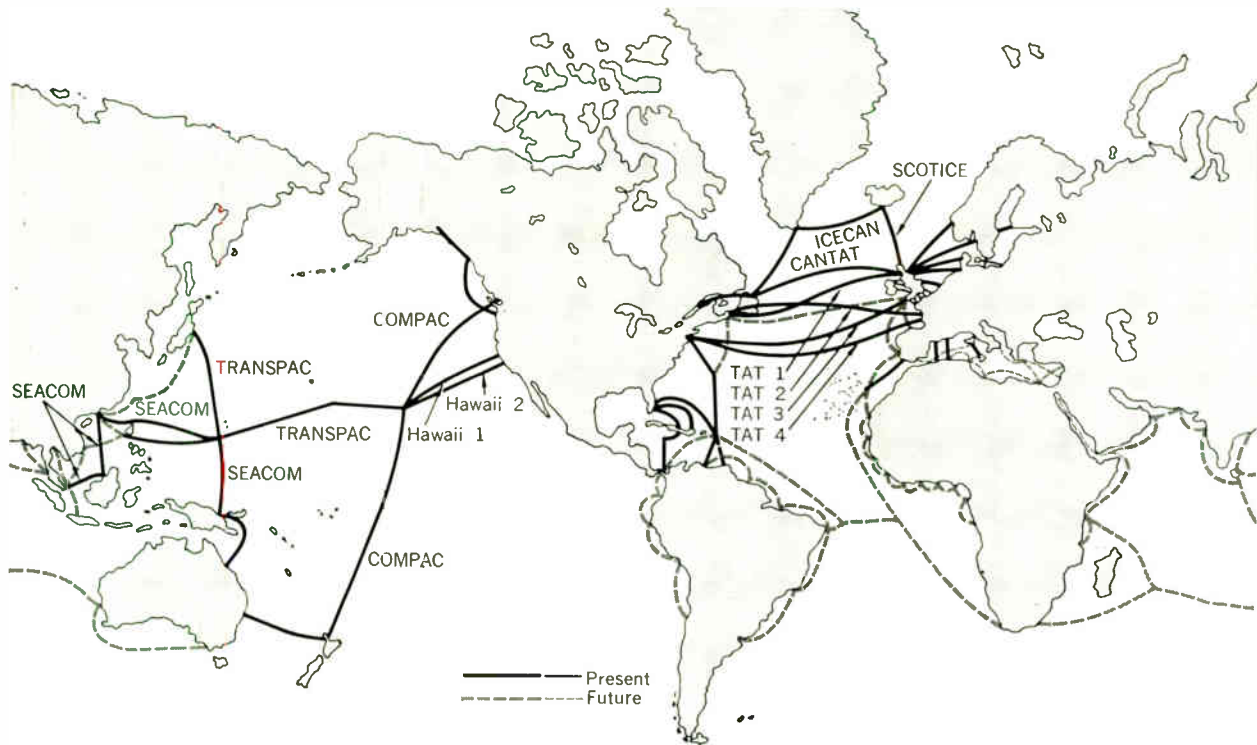
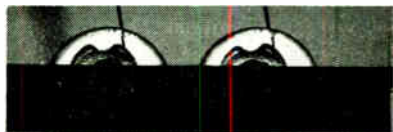

Fig. 3. Submarine cable network as predicted for 1980.



## Progress in worldwide telephone dialing

*Lowell F. Wingert* American Telephone and Telegraph Company

Within the framework of the overall topic of compatibility, this article will focus on past and future progress in worldwide telephone dialing.

Today we are at the two-thirds mark in the 20th century, and although there is still some recounting of the "good old days," most people are more interested in the future. This attitude seems especially true of engineers and others in the communications field. Engineers may complain about change, yet they are the first to become dissatisfied when the changes they are seeking don't materialize quickly enough. In this spirit, most of what I have to say will deal with future plans and prospects for worldwide communications.

Some day all of the world's telephone users will be able to dial each other directly. Why is global dialing needed, and how and when might it be achieved? What

steps are being taken now to bring about this achievement? First, like most things, the prospect of truly international communications has its roots in the past, and so I would like to review briefly some of the major developments that have led to the promising future prospects we see today.

Ninety years ago, another telephone man, Alexander Graham Bell, brought his invention to Philadelphia's Centennial Exposition. He was able to convince Dom Pedro, the Emperor of Brazil, that his device might have merit and the Emperor agreed to place a call across the convention hall to Sir William Thomson (Baron Kelvin) of England. When the contraption actually worked, Dom Pedro turned to Mr. Bell and said: "You have made an invention that will change the way people live all over the world."

Even though this call only spanned a convention hall, I like to think of it as the start of international cooperation in telephone communications. This cooperation has gone a long way toward making Dom Pedro's prophesy a reality.

#### **A beginning is made**

A major breakthrough in transoceanic telephone communications occurred in 1915 when the first transatlantic radiotelephone transmission from Arlington, Va., was heard atop the Eiffel Tower in Paris. Twelve years later, in January 1927, commercial radiotelephone service between New York and London was inaugurated. To pave the way for the expected growth in overseas calling, the nations of the world held an International Radiotelegraph Convention in Washington in that same year, and at this meeting agreement was reached on the establishment of interference and wavelength regulations.

During the next three decades, overseas telephone service took a tremendous leap forward. In 1927, when overseas service from the United States included only points in Great Britain and Cuba, there were 11 750 calls, and just 2300 of these were transatlantic calls. By 1955, when telephone users here could reach points in 108 countries or territories, the number of calls had soared to 1 750 000. (These figures do not include calls to Canada or Mexico, which totaled 8 500 000 in 1955.)

Then, in 1956, overseas telephony entered a significant new era. The first transatlantic cable, linking North America with Great Britain, was put into service in September of that year. This was a joint, cooperative undertaking on the part of AT&T in the United States and the British and Canadian telephone systems.

The transmission quality of cables made overseas calls as clear as those from across the street, and beginning in 1956 the demand for service began to accelerate even more rapidly. The number of calls between the United States and overseas points increased fourfold in the next decade, reaching 8 100 000 by 1965. The annual growth recently has been about 20 percent.

To accommodate this great increase in overseas telephoning, we have increased the number of overseas message circuits at an even faster pace. While calling volumes have quadrupled, circuits have been increased almost seven times in the past ten years, thus permitting significant improvement in the speed of overseas service.

Not only have new cables been added in quick succession, but they have been made more efficient. Through improved cable design and the development of better terminal equipment, the capacity of underseas cables has been increased steadily. The first transatlantic cable provided 36 voice-grade circuits initially; the latest cables in use provide a capacity of 138 circuits.

This year marks important additions to the worldwide network. One is the cable from St. Thomas in the Virgin Islands to Venezuela, which provides the first physical communications link between North and South America. Another new facility is the British-built Bermuda-to-Tortola cable, which later will be linked with an over-the-horizon radio system to Trinidad. These routes also will connect with facilities in the U.S. Virgin Islands and from there to the U.S. mainland or Venezuela. In the Pacific, the British "Seacom" cable, which will link

Hong Kong, Guam, New Guinea, and Australia, will substantially improve telephone communications to and from that region of the world.

For the past year, of course, we have been taking advantage of an exciting new tool for telephone—the communications satellite. The American Telephone and Telegraph Company and the Bell Telephone Laboratories, along with several telephone administrations abroad, played a pioneering role in the development of satellite communications. The significant successes of the world's first active communications satellites, Telesat I and II, helped move space communications from the realm of fantasy to the world of fact.

Today we are utilizing 64 circuits to Europe in Comsat's Early Bird satellite, which is owned jointly by an international consortium. With the launching by Comsat of two improved satellites designed to provide communications support for the Apollo moon-landing program, commercial communications capabilities also will be extended to the Pacific and other areas. And the future will see a constantly expanding need for more and better satellites as well as more and better cables.

#### **Increased demand—and supply**

The task ahead is tremendous. There are 195 million telephones throughout the world today. Our estimates indicate that there will be 500 million by 1980, or more than 2½ times as many. As domestic telephone systems expand in the years ahead, global communications will play an increasingly important role—in handling personal, business, and governmental matters, and in providing a link to help build understanding in our ever-shrinking world. Overseas calling volume is expected to grow at an even faster pace than the number of telephones. By 1980 we estimate that there will be more than 70 million calls, or nine times as many as in 1965. How are we going to meet these demands in the years ahead?

First, I am confident that the circuit requirements can be met—the technology to meet future needs is now out of the laboratories and on the drawing boards. Certainly satellites will play a major role in tomorrow's communications, and cables also will continue to play a full role. Like satellites, ocean cables constantly undergo study and improvement. When the first transatlantic cable was laid, it had a capacity of 36 voice circuits, and this was just ten years ago. Now Bell Laboratories has designed a transistorized cable with a capacity of 720 voice-grade circuits, and AT&T has filed with the FCC for permission to build one between Florida and St. Thomas.

All of this points to the fact that both cable and satellite facilities will be needed in the future. The development of one will spur the development of the other; and the two together, along with radiotelephone and other methods, will provide the diversity required to assure dependable service.

However, providing the circuits for worldwide communications is only one aspect of the job ahead. Future growth will mean a multiplying need for international cooperation, and an even closer compatibility of methods, equipment, and goals. An ultimate goal, of course, is to make it possible for all of the world's telephone users to dial one another directly. Why is this so difficult? Why is compatibility among the world's telephone systems so important?



## The dial problem

Telephone dialing can hardly be described as a recent development. As far back as the 1880s engineers were studying its feasibility. By the early part of the 20th century many telephone users were able to place local calls without assistance. Today a customer can span a continent by the spin of a dial or the push of a button, but intercontinental dialing still is not at our fingertips.

Why not? If we can dial directly to California from Philadelphia, why can't we reach Geneva or Brussels or London the same way? Although it is technically feasible, the overall communications systems of each continent have enough inherent differences to make mixing them a formidable task. However, I am convinced that intercontinental telephone dialing by customers will soon be possible, in large part because of the efforts of the ITU's International Telegraph and Telephone Consultative Committee (CCITT).

Through the efforts of the CCITT, a great deal of progress has been made in the quest for global dialing and agreement has been reached in a number of basic problem areas, including international switching arrangements, techniques for language assistance, and a world routing plan. Also, a worldwide telephone numbering plan has been developed. In this plan, the world is divided into nine numbering zones. Within each zone, code numbers have been assigned for the various countries, similar to the way in which we have divided the United States into numbering areas. The CCITT numbering plan sets up a maximum of 12 digits for a world telephone number, plus a special access code that tells the equipment that the call is destined for overseas. To call Geneva, for example, you would first dial an overseas access code, then the country code, the area or routing code, and then the local number—in this case only ten digits in all, not counting the access code.

There are still a number of steps to be taken, of course, before this plan can be put into effect on a global basis. A major one will be the conversion of the world's telephone systems to all-number dialing instead of a combination of letters and numerals. One compelling reason for this in the United States is growth, because the use of numerals provides necessary additional numbering combinations. Another basic reason for conversion is to achieve uniformity among the telephone systems of the world.

In the United States, we use a dial with 24 Roman letters. We would have trouble in calling Moscow and dialing an exchange prefix with Russian Cyrillic letters, and vice versa. And how would the Danes, who have no "W" on their dials, manage to call a WALnut exchange number here? On the English dial, the letter "O" is associated with the "zero" whereas it is in the number 6 hole on American dials. Finally, some countries, such as Sweden and New Zealand, have no letters on their dials at all.

In spite of these obstacles, a good beginning has been made. Overseas customer dialing will be introduced, on a gradual basis, starting in 1970. To help identify from experience the problems that may be encountered, AT&T plans to explore the possibilities of a limited trial of the service in 1967 between selected central offices in New York and several European cities.

Actually, international—if not intercontinental—customer dialing is already in use in some places. In Europe,

calling between countries is fairly commonplace through subscriber trunk dialing. In the United States, we can call Canada in the same fashion that we telephone from state to state—and of course direct distance dialing is available for almost all of these calls. Also, overseas points such as Bermuda, Jamaica, Puerto Rico, and Hawaii, which follow the North American plan for distance dialing and have adopted our domestic operating practices, can be dialed directly by any long-distance operator in the United States. These calls do not have to go through an overseas gateway operator, because the same systems, practices, and equipment are employed at both ends.

## The transition

For the rest of the world, the task will not be so simple, even though the groundwork has been laid for the transition. In making an intercontinental call today, two operators are required. For example, in a call from Chicago to Paris, you first dial the Chicago long-distance operator and tell her you wish to call Paris; she then connects you with the gateway operator in New York City. Until three years ago, the same process had to be repeated on the distant end of the call. Since 1963, however, it has been possible for overseas operators to dial directly to telephones in a number of countries, and more countries are being added to the list each year.

The world's largest overseas gateway office is the New York City gateway, which is one of four in the United States. The others are in White Plains, N. Y.; Miami, Fla.; and Oakland, Calif. From these four points we are able to reach some 98 percent of the world's telephones.

The New York City gateway handles some 7000 overseas calls to and from this country a day. For this service, 500 operators and supervisory personnel are employed. By enabling an overseas operator to dial a distant telephone directly, we have provided faster and more efficient service. And, once worldwide compatibility has been achieved, there is no reason that individual customers cannot dial their own overseas calls just as easily.

I said previously that AT&T plans to introduce overseas customer dialing on a gradual basis beginning in 1970. Although the "1970" is probably the most interesting part of the statement, I would like to stress the word "gradual," because the extension of this service to all the telephones in the United States will require several years. For one thing, it is a big job; modifications must be made in the digit storage capacity of switching and automatic accounting equipment in long-distance offices across the country. Second, these modifications will need a substantial financial investment. However, necessary modifications will be made as quickly as possible, with portions of busy metropolitan areas getting the new service first.

At the beginning of this article I said that some day all of the world's telephone users will be able to pick up a telephone and dial one another directly. I need not point out that there is more to this goal than the mere technical accomplishment. What all of us are trying to achieve ultimately is better communication among the peoples of all nations; and through this, hopefully, we will have helped to develop better understanding throughout the world.

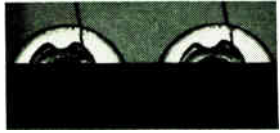

# The CCITT and automatic worldwide telephony

*Marc Lambiotte* *The Belgian Telephone and Telegraph Administration*

In 1924, the French telecommunications administration suggested that an organization to include all European administrations be formed so that standard procedures might be set up to facilitate establishment of international telephone connections. This organization subsequently was created as the International Telephone Consultative Committee (CCIF), under the chairmanship of a French engineer, Georges Valensi.

Shortly thereafter, the International Telegraph Consultative Committee was formed to consider international telegraph questions. Although these two organizations began independently, they were later brought together under the International Telecommunication Union with headquarters in Geneva, and then were further merged in 1956 as the International Telegraph and Telephone Consultative Committee (CCITT). For many years the director of CCITT has been Jean Rouvière, who was previously director-general of telecommunications in France.

The activities of the CCITT are very diverse; through its numerous study groups it is now considering all problems relating to the establishment, operation, and maintenance of international telephone and telegraph connections. In this article I shall not attempt to make a complete inventory of these activities, but instead shall stress the intervention of CCIF, and later of CCITT, in a problem of cardinal importance to the administrations and operating companies and also the subscribers.

This problem involves the implementation of standard procedures for establishing and operating semiautomatic and automatic international telephone connections.

## Preliminary studies

Credit should be accorded the CCIF for deciding soon after World War II to standardize on a system for an international semiautomatic telephone service suitable for all European and Mediterranean countries. The system must work satisfactorily with all kinds of calls and must be adaptable to all stages of automation. It also must take into account the extreme diversity of European languages and be sufficiently flexible to be used later for establishing fully automatic calls in Europe, as well as in North America. (It should be noted that by semiautomatic operation is meant the procedure by which an operator can reach every subscriber solely by operation of her keyset.)

Only ten years after the first studies of the system were begun, fully automatic telephone services already were replacing semiautomatic and manual systems. In 1956 Belgium instituted the first fully automatic connection, between Brussels and Paris. This example was soon followed by other European countries such as France, the North countries, the Netherlands, and Germany.

The studies initiated by CCIF were the result of decisions at the Plenary Assembly in London in October 1945 (only a few months after the end of the hostilities). A group of specialized engineers, called the 8th Study Group, was created with the objective of studying the technical aspects of switching and telephone signaling on an international level. At the same time a subcommittee grouping engineers and representatives of the operating companies, the Subcommittee on Rapid Operating Methods, was charged, under my chairmanship, to undertake preliminary studies involving all technical and operating features with regard to their application to semiautomatic services. This subcommittee has since become Study Group XIII. Its new name—Commission for Semi- and Fully Automatic Networks—indicates the broadening of its range to include complete automation of international communications. The primary group, the 8th Study Group, became Study Group XI with the merger of the CCIF and the CCIT as the CCITT.

The problem to be solved was of such widespread and diverse character that probably no international organization had ever considered it before. Among the questions to be examined, the most important, of course, was the choice of signaling system.

As early as 1946 new signaling methods were proposed, but a difference of opinion arose among the various European administrations. One school recommended

Fig. 4. Schematic of one-frequency system.

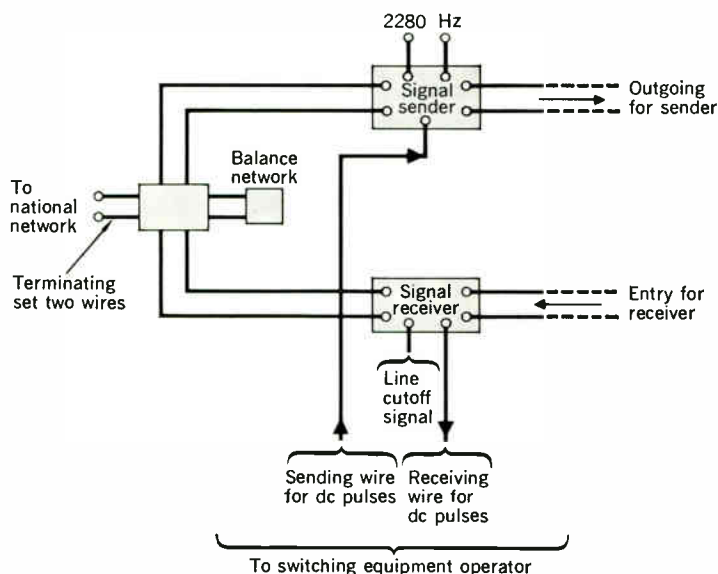

a single signaling frequency of 2280 Hz on the basis of their internal studies and because of the system's simplicity; this system was the one-VF system. A second group favored a system using two signaling frequencies because of the greater number of signals available (two-VF system).

### **One-VF system**

In order to extend the range of signals for the one-VF system, it was necessary to devise three additional types; i.e., short signals of 150 ms, long signals of 600 ms, and signals composed of two short signals or two long signals separated by an interval of 100 ms. However, the number of available signals still was insufficient to meet technical and operating requirements, and it became necessary to assign different meanings to some signals, based on their hierarchic position in the sequence. For example, the busy flash and clear back signals are identical, but the first comes before the answering signal whereas the second comes after.

It should be noted here that in both the one- and two-VF systems, which developed simultaneously, the signals are all transmitted on the speech path. The adopted signaling frequencies are in the speech band that generally covers the range of frequencies from 300 to 3400 Hz. As shown in Fig. 4, these voice-frequency signals activate an electronic receiver that transforms them into dc signals; these, in turn, activate the automatic switching equipment.

A very important problem that arises is the immunity of the receiver against the human voice. The signals cannot be discriminated from speech by using a higher transmission level for them, because the line amplifiers should not be saturated. It has therefore been necessary to provide the receivers with a guard circuit that, in principle, avoids activating the receiver when the signaling frequency is merged among other frequencies. Furthermore, the signaling frequency has been chosen from a part of the spectrum where the energy of the human voice is at a minimum.

However, the human voice is able to initiate some pure frequencies of very short duration against which the receiver is not immune. For this reason each signal should remain for a period of time—called the “recognition time”—before it is accepted by the switching equipment. Another way to avoid voice imitation of these signals would be to transmit them over a separate channel, but such a solution would be too complicated and costly.

The system presently under study, which was especially designed for worldwide communications, will have far more extended operating facilities than existing systems. It will make use of a separate channel for transmitting both numbering and line signals, and this separate channel will be common to a large number of speech circuits. This system will be discussed further in a subsequent section.

### **Two-VF system**

Some of the administrations were adamant in their advocacy of a signaling system using two voice frequencies—2040 Hz and 2400 Hz—on the basis that such a system would avoid signal imitation by the human voice and would provide a relatively large number of distinct signals. Most of the line signals comprise a prefix com-

posed of the two frequencies sent simultaneously, and a suffix composed only of a single frequency—the duration of which can be short or long. In order to interpret a specific line signal correctly, immediately after a signal is received the switching equipment should be brought into a convenient position by the prefix. Voice imitation of such a signal is practically impossible and the integrated guard circuits become relatively simple.

The two systems are also completely different in their method of routing calls through one or several transit centers. In particular, the two signaling codes are designed to permit calling at the incoming international center for an incoming operator or for an assistance operator. The incoming operator is needed when the called subscriber cannot be reached by the outgoing operator; for example, when the called subscriber is situated in a nonautomatic network. The assistance operator enters the connection when requested by a signal sent by the originating operator to help her to interpret the significance of certain tones, or to translate when the called subscriber does not use the language of the originating operator. Because of the diversity of languages in Europe, it was decided to add a language digit to each call to indicate in the incoming country the language that should be used with the outgoing operator.

### **Field trials of the two systems**

In face of the impossibility of obtaining agreement on a system choice, and in order to assess the comparative reliability of the two systems in actual service, the CCIF decided to make extensive field trials.

The trial results showed that both systems worked satisfactorily and that they were nearly equivalent. Faced with such a situation, the CCIF decided to accept both systems for direct connections between countries but to standardize on the two-frequency system for connections utilizing transit centers because this system offered greater operating facilities.

### **Numbering plan**

The CCIF also had to conceive a valid numbering plan for Europe and the Mediterranean countries that would provide for the possibility of later connections to other continents. A code of two digits was set up for each country, with some exception for very large countries. The series 90 to 99 was reserved for inter-continental traffic.

Another important problem arose concerning the limiting of the total number of digits to be sent to reach a subscriber in another country. In some European countries, the plan is based on “open numbering,” which means that the number of digits pertaining to different subscribers can vary greatly; including the trunk code, it may be as many as ten. For these countries, the CCIF recommended that the trunk prefix be limited to one digit in the event that this prefix was also a part of the national number.

In an extreme situation, a total of 14 digits might thus be necessary: international code, 2 digits; language digit, 1 digit; national number including eventually the trunk prefix, 11 digits maximum.

### **From semiautomatic to fully automatic operation**

In view of their success in fully automating their national toll networks, several West European countries

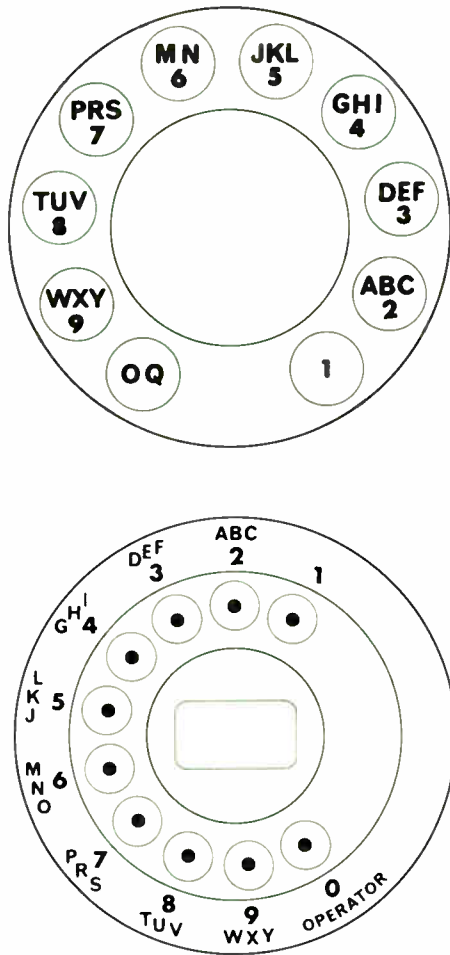

Fig. 5. Telephone dial used in France and Great Britain (top) and that used in the United States (bottom).

decided to introduce the same service on some of their international connections that were already in semi-automatic operation.

In the years preceding the Plenary Assembly at New Delhi in 1960, the CCIF, which had become the CCITT, examined methods by which existing operating and technical arrangements would be modified for the change-over from semi- to fully automatic operation. A pending problem was that of variable-length numbers. The solution is simple for semiautomatic systems, in which the operator sends a keying-finished signal that tells the register at the outgoing center to release as soon as the transmission of all of its information is finished.

In automatic service in which a call is directed toward a country with a variable number of digits, the outgoing register does not know the number of digits it will receive when the number is complete. The difficulty has been resolved by designing the incoming switching equipment to send a "number-received" signal, so that the outgoing register can be released and the circuit can pass into conversation condition.

#### Diversity in dial designs

Another problem in automatic international service is concerned with the dials used in the various countries, in particular, the position of the numbers and the use of

both numbers and letters. The CCITT has standardized on the dials used in France and Great Britain, which differ only by the absence of the letter "Q" from the British dials. As shown by Fig. 5, this standardized dial is unfortunately somewhat different from that used in the United States and Canada. On the latter dial the letter "O" is associated with "M" and the letter "Q" is absent.

#### From European to worldwide service

The CCITT Plenary Assembly at New Delhi marked an important turning point in the evolution of international cooperation with regard to telecommunications, particularly in the matter of international semi- and fully automatic services. It was decided to review all the CCITT's previous recommendations with regard to converting to a worldwide numbering plan. A study will have to determine the best solution to the problem; however, I believe that automation of the traffic between the two continents will take place within the next five years.

At this time AT&T and some large European countries had almost finished a series of common studies directed toward setting up intercontinental semiautomatic connections between Europe and North America, and in particular a system that took into account technical and operating conditions in the United States and Canada. In this system the frequencies 2400 Hz and 2600 Hz are used for the compelling line signaling. For the digital signals, there are six signaling frequencies, from 700 to 1700 Hz. A signal consists of a combination of any two of these six frequencies.

Study Group XIII was asked to restudy the numbering plan with a view to extending it on a worldwide basis, and also to set up a routing plan for intercontinental traffic to achieve high-quality, economical interconnection of any subscriber with any other in the world. Together with Study Group XI, which is responsible for switching and signaling, Study Group XIII was charged to examine to what extent the system studied by AT&T could meet the standard operating conditions specified by CCITT, and to ascertain whether it could be used in a worldwide plan.

The new numbering plan, which was approved in principle by the Plenary Assembly in Geneva in 1964, comprises nine regions characterized by the digits 1 to 9 as the first figure of the country code. Contrary to preceding provisions, the number of digits composing the country code will now vary between one and nine, depending on the probable development of a particular country. The aim of these provisions is to limit the total number of digits to be used in the intercontinental automatic service. After numerous discussions, which particularly involved AT&T and some large European countries having open numbering, a compromise was found that limited the maximum number to 12 digits instead of the 14 digits previously allowed.

Because intercontinental signaling must utilize submarine cables and cables with increased transmission capacities (TASI), the CCIF signaling systems standardized in 1954 could not be used. However, the introduction of semielectronic, and perhaps fully electronic, switching equipment will bring with it an increase in operating facilities. A signal system for worldwide operation must include all these facilities and the signaling

code must be augmented by other signals. One factor to be considered is the influence on loading of long circuit groups as a result of the differences in time at different points on the globe. Thus, at the first meeting of the CCITT study groups following the New Delhi Assembly, it was decided to introduce a completely new system that would be usable for a long time to come.

Simultaneously, and in anticipation of the more immediate future, it was decided to examine to what extent the existing semiautomatic system between Europe and North America could meet the conditions imposed by the standardized one- and two-VF signaling systems. The signaling code is less extensive than those of the one- and two-VF systems, but because the system meets the chief operating requirements for the present and near future, it was adopted as an intermediate step.

A very important question arose as to the possible utilization of this system for fully automatic operation. After careful study, two weak points appeared: (1) a substantially long "post-dialing delay"; and (2) a significant transfer delay of the answer signal and the subsequent passage into the conversation condition, a delay that could cause the calling subscriber to release the connection. Provisions have been made to reduce the effects of these inconveniences and the transatlantic system has been accepted as CCITT standard system no. 5, with its application limited to direct connections

without transit centers. The one- and two-VF systems have been designated as system no. 3 and system no. 4.

#### **A system for the future**

The study of an entirely new system, no. 6, has been under way for the last few years by Study Group XI. In this system, the signals will be transmitted over a common separate channel, distinct from the speech channels. This means that the signaling will be completely immune to imitation by the human voice.

The signals on the separate channel will be transmitted at a very high speed on a data transmission basis, and thus a single separate signaling channel can be used to serve a large number of speech channels. The matching of separate channel signals with the speech channels to which they correspond will occur electronically at each end, with each signal carrying the address of the corresponding speech channel.

The studies, which will concentrate on the economic aspect, undoubtedly will lead to numerous other discussions, but it is foreseen that specifications, or at least detailed proposals, will be ready for presentation to the 1968 Plenary Assembly.

When the no. 6 system is finally achieved, it will stand as a prime example of international cooperation—and as one of the most striking accomplishments of the CCITT.

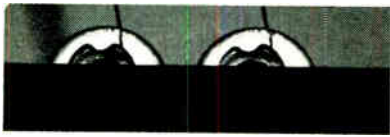

## Compatibility in world communications

*R. H. Franklin*    *General Post Office, Great Britain*

In the telephone business, compatibility is a fundamental necessity; any telephone instrument used anywhere in the world on a public network must be able to interwork with any other telephone in the world. That this compatibility has been achieved, despite the development of telephone systems that were originally purely national in character and despite a notable lack of equipment standardization, has been due largely to the close cooperation that has become a feature of international communications.

The achievements so far have been remarkable, particularly when it is realized that the various designs of telephone instruments, exchange systems, and transmission equipment span half a century, yet are compatible. Compatibility tends to occur naturally since at any point in time not only are there technological and economic limitations on designs, but also the new must interwork with the old. However, differences tend to arise between countries because of other factors, such as varying rates of growth of telecommunications services in different parts of the world. The installation practices and maintenance philosophy of operating organizations can also have a profound effect on system design. Nevertheless,

in most of the areas where difficulties have arisen, an acceptable compromise has been arrived at, and as a result of the interchange of opinion and discussion of concepts involved in reaching the solution, much benefit has often been gained by all parties.

#### **Telephone instruments**

It was soon realized by early telephone engineers that broad standardization of certain essential parameters was needed to ensure compatibility. For example, although the basic telephone instrument techniques were the same in various countries—carbon microphone and electromagnetic receiver—there was considerable scope for varying the difference between the receiving efficiency and the sending efficiency. A good receiving efficiency might be considered the more important since this naturally tends to reduce the number of complaints with regard to international calls.

For many years, the CCITT has made recommendations concerning the electroacoustic performance of telephone networks in terms of "reference equivalent," which is a measure of the volume efficiency of telephone instruments, taking no account of articulation or clarity.

In fact, as new telephone instruments with improved frequency response come into use, volume efficiency is now becoming the only quantity that it is still necessary to specify.

The difference between the sending and receiving reference equivalent recommended by the CCITT is 8.6 dB. When the differences are not the same in a connection between two countries, the two directions of transmission will have different overall reference equivalents.

This problem is still being actively studied by the CCITT and the various new telephones may yet be brought still more into line. The incorporation of semiconductor devices into future telephone instruments could give designers a much greater flexibility of approach in this respect.

### Carrier systems

**Channel spacing.** The development of carrier telephony systems on both cable and open wire was given great impetus in the 1930s by the introduction of negative feedback amplifiers, but the systems produced in Europe and in the United States would have been completely incompatible if interconnection had been contemplated at that time. Within Europe, where interconnection of national systems was of major interest from the beginning, a choice had to be made between 3-kHz and 4-kHz channel spacing on transmission systems used for international connections.

At the CCIF Oslo meeting in 1938, 3-kHz spacing with an effective channel bandwidth of 300–2700 Hz was sponsored by Germany, on the basis of experience with double-modulation equipment using *L-C* filters. The alternative 4-kHz spacing (effective channel bandwidth of 300–3400 Hz) was sponsored primarily by the United Kingdom and was based on British and American practice, crystal filters being in general use. The latter spacing was finally adopted. However, the British equipment being made at that time used the upper sidebands of the channel carriers, and inverters had to be used to bring the groups into line with the new international standard.

The choice of 4-kHz channel spacing was confirmed after the war, and a wide variety of line and radio systems were developed, all using compatible basic groups, either 12–60 or 60–108 kHz with carriers spaced at 4-kHz intervals. Without this compatibility, international telephony on the present scale could well have become almost impossible. The basic group B (60–108 kHz), in which all channels appear as the lower sidebands of the channel carriers, is now widely used throughout the world, but there is a small but significant difference between the Bell System and the CCITT standard audio bandwidth. The effective bandwidth in the Bell System is usually taken as 200–3200 Hz, whereas the CCITT recommendation is 300–3400 Hz.

The adoption of 3-kHz spaced channels as the standard for transoceanic submarine cable systems introduced a further complication. Using high-efficiency filters, an effective bandwidth of 200–3050 Hz can be achieved. The voice bandwidth on many intercontinental calls over a submarine cable link is thus restricted to some 300–3050 Hz. The subscribers have the worst of both continents—they lose bandwidth at the top of the audio-frequency band to gain an additional 100 Hz at the bottom, which

is then lost in the European national networks.

On short-haul systems not used for international connections, different carrier spacings have been used. In the Netherlands, for example, 6-kHz spaced channels are used for internal circuits, whereas the N-type carrier system using 8-kHz spacing and double-sideband transmission has been installed widely in North America. Systems developed on principles similar to the N-type system have apparently never proved economically viable in Europe. Why this should be so has never been satisfactorily explained, but because of this, the incompatibility problem has not arisen there.

Although the basic group band occupied is the same for both 3-kHz and 4-kHz spaced channels—12 4-kHz spaced channels or 16 3-kHz spaced channels occupy the basic group band of 60–108 kHz—a 3-kHz spaced group cannot readily be transmitted over a standard inland group path because of the presence of virtual group and supergroup carrier leaks at 4-kHz intervals, some at relatively high levels. The removal of these interfering signals over a long inland route is time-consuming and expensive. The alternative, to interconnect at audio frequencies, is expensive in terminal equipment and introduces circuit impairment due to additional demodulation and remodulation stages. Nevertheless, the adoption of 3-kHz spacing for transoceanic submarine cable systems is justified on economic grounds, and when time assignment speech interpolation (TASI) systems are added, the combination provides maximum utilization of the available cable frequency spectrum.

However, for the intercontinental satellite systems that are becoming a major feature of global communications, 4-kHz channel spacing has been adopted. These satellite systems use frequency modulation over the radio path and there is no advantage in choosing a narrower channel bandwidth. The additional power associated with a 3-kHz spaced channel requires additional radio bandwidth that could equally well have been used to provide additional 4-kHz spaced channels. In addition, with the wide-band satellite systems that are now becoming available, through groups and supergroups can readily be provided and onward transmission of these large blocks of circuits on overland plant will be simplified if 4-kHz spacing is used throughout.

**Supergroups and mastergroups.** The standardization of the frequency bands of the basic supergroups became essential for the through connection of increasingly large blocks of traffic circuits as the telephone service expanded. However, the same degree of standardization has not been achieved in the assembly of supergroups into large blocks for transmission over wide-band systems.

Two frequency arrangements that are incompatible in the line-frequency range have been recommended by the CCITT for 12-MHz coaxial line systems; one is an assembly of three 15-supergroup blocks, each block corresponding to a 4-MHz coaxial line system, and the other is an assembly of nine mastergroups, each mastergroup comprising five supergroups. A third variant has also been recommended by the CCITT in which six 5-supergroup mastergroups are used above the basic 4-MHz block.

In the Bell System, which does not use the CCITT 12-MHz system, the L3 10-supergroup mastergroup differs from the 5-supergroup mastergroup, subse-

quently adopted by the CCITT, because it was a development of the L1 frequency plan. The 18-MHz L4 coaxial line system allocations are a further extension of this frequency plan.

Thus, incompatibility has resulted not only within Europe but between Europe and North America. So far this has not been a serious problem. Within Europe the largest block of circuits generally used for international links is the supergroup, and until recently, intercontinental circuits were provided by submarine cable systems with relatively small capacity, and for which special frequency arrangements had to be made. However, with traffic growth and the availability of large-capacity satellite and submarine cable systems, mastergroup incompatibility could become a major obstacle to the efficient utilization of this type of system.

### **Pilots**

**Group pilots.** On long-distance groups and supergroups, reference pilot signals are used for control and maintenance purposes, and differing national practices have led to some complicated arrangements on international links. In particular, the group pilot frequency adopted in the United Kingdom, and in most countries outside the United States, as an end-to-end reference pilot is 84.08 kHz, one of two frequencies recommended by the CCITT. This pilot is used to control AGC equipment, which maintains the overall loss of the group within close limits as well as providing an in-service maintenance aid. On certain routes in the United Kingdom that carry transatlantic traffic, the failure of this pilot initiates the changeover to a standby facility. The pilot frequency is offset 80 Hz away from the carrier frequency of 84 kHz to avoid interference from channel carrier leaks, but in France, where the virtual carrier frequencies are used for signaling purposes, an 80-Hz offset was insufficient and 84.140 kHz is used (the second CCITT recommendation).

In the Bell System, a 92-kHz pilot was used for monitoring the transmission path over a group section; this did not seem incompatible with the European 84.08-kHz end-to-end pilot, as the two pilots performed different functions. However, when the first transatlantic telephone cable was laid, difficulties arose with carrier program equipment. The use of the standard British Post Office system using the frequency band 84–96 kHz was impracticable due to the 92-kHz pilot, whereas the standard Bell System equipment using the frequency band 80–88 kHz was unsuitable due to the 84.08-kHz pilot. New equipment had to be designed that operated in the frequency band 64–76 kHz.

It later became apparent that the presence of the 92-kHz pilot might inhibit the rapid expansion of wide-band data service in the Bell System, and that an edge-band end-to-end pilot was preferable to section pilots. It was decided to change to an end-to-end group pilot of 104.08 kHz, thus leaving the 64–104-kHz band available for high-speed data. The pilot is 4 kHz removed from the edge of the group band as this is sufficiently clear of the effects of transmission path filters to give a reliable indication of transmission performance. Tests carried out in the United Kingdom on groups routed on coaxial plant have confirmed that the mean differences between an edge-pilot and a midband-pilot indication are small.

Strictly speaking, these different pilot frequencies are not incompatible, but we have already had difficulty with program equipment and it seems that in the future any requirements for multiple bandwidths (8, 12, 16 kHz, etc.) may be impossible to meet because of our failure to reach international agreement on a common standard. However, there is some support in Europe for a change of group pilot to 104.08 kHz for special-purpose groups, and hopefully we may eventually have general agreement on a frequency around 104 kHz—although this decision will affect the choice of supergroup pilot frequency.

**Supergroup pilots.** The supergroup pilot in use in the United Kingdom is 411.92 kHz, whereas the French use 411.86 kHz and the Bell System uses 315.92 kHz (i.e., group 1 pilot). The Bell System choice depends on the dual use of a single pilot, and presents problems for worldwide use since the group and supergroup terminals may be at different geographical locations.

### **Television**

The immense potential of satellite systems for intercontinental television transmission has yet to be fully exploited, partly because of the incompatibility that exists in the differing video- and radio-frequency characteristics in use in various parts of the world. These differences preclude direct pickup, one of the very exciting prospects now in view and one that could be a major force in world affairs. Although the necessary satellite transmitter powers probably will be achieved, the present incompatibility cannot easily be resolved.

For example, provision of the necessary bandwidth on a point-to-point basis is no problem; both the North American 525-line 60-field-per-second system and the European 625-line 50-field-per-second system occupy a similar video bandwidth. Line standards conversion where field repetition rates are the same is relatively simple, either by means of the display tube/vidicon camera technique or by all-electronic methods. Such conversions have long been a feature of the Eurovision network. However, where field repetition rates are different, electronic conversion becomes rather complex.

The compatibility problems of monochrome television are severe but are overshadowed by the difficulties of color. Despite the protracted international discussions on color systems and the fair measure of agreement achieved so far, we have a long way to go before globally compatible color television becomes a reality.

### **Operating and maintenance**

**Testing signal.** Apparently trivial differences in operating and maintenance practices often lead to wide-ranging problems in international communications. A case in point is the frequency of the audio testing signal used when setting up and maintaining international circuits.

In Europe the CCITT-recommended frequency of 800 Hz is in general use, whereas in North America the standard is 1000 Hz. There is obviously an advantage in international standardization on one frequency in order to avoid misunderstandings and ambiguities; circuit performance and equipment specifications are also related to two different “reference” frequencies. This pointless difference in test frequency should never have happened and should be abolished; but there are formidable obstacles, because not only must specifications, instruc-

tions, and documentation for operating and maintenance personnel be revised, but thousands of fixed-frequency test-signal generators must be modified or replaced.

**Noise measurement.** A similar situation has arisen in noise measurement. In North America, noise is now measured in dB<sub>rnc</sub> (decibels above reference noise, "C" message weighting), which has superseded dB<sub>a</sub> (decibels adjusted, FIA weighting), whereas in CCITT recommendations the principal units of measurement are psophometric voltage or power. In system design, noise performance is often specified in picowatts, psophometrically weighted.

The noise-measuring instruments in use in Europe and North America are basically similar in design; they consist of a weighting network followed by an amplifier, a square-law detector, and a meter circuit with an integrating time of 200 ms. The main difference lies in the design of the weighting network, which reflects the interference effect of noise in relation to the telephone instruments in general use in a particular network.

In the Bell System, the FIA network was introduced for use with the Western Electric 302-type telephone and the "C" message network for the Western Electric 500-type telephone. The CCITT (1951) network was introduced for use with telephones that were widely used in the European telephone network at that time and has substantially the same response as the FIA network. The C-message weighting network, however, has a response that differs appreciably from the CCITT telephone network.

Conversion from one unit of measurement to another is relatively simple when the detector laws and weighting characteristics are the same, but there is always the chance of error, and this is one more difficulty in the way of successful international telephone transmission.

**Transmission units.** In Europe, two transmission units have been in common use for many years—the decibel and the neper. This has not proved too troublesome, although many administrations have had to equip their international centers with transmission measuring equipment that will measure in both units. Recently, however, there has been discussion in the CCITT with the object of reducing the level of the test signal used for audio-frequency tests on circuits to a value lower than the 0 dB relative to 1 milliwatt (0.0 neper) that has been used up to the present. A value of -10 dBm has obvious appeal to countries using the decibel notation, but the equivalent test level in neper notation is -1.15 Np, a rather inconvenient quantity for general use. If -10 dNp is chosen, an equally inconvenient decibel value arises.

**Automatic testing.** The merits of a round number for the test signal level are less apparent when automatic testing of circuits is considered, and perhaps agreement on the low-level test signal can more easily be reached in this context. The rapidly rising number of circuits in the international network, coupled with the introduction of international subscriber dialing, has underlined the need for automatic circuit transmission measurements.

The CCITT has been studying this problem for several years, and in Europe a field trial has started of an experimental automatic measurement equipment, with 11 countries participating. The equipment will be provided by several manufacturers and will meet the requirements of a specification drawn up by the CCITT. The equipment will measure circuit loss at 400, 800, and 2800 Hz, and

also will compare the circuit noise with a preset threshold level. The results of all measurements are printed out at the two ends of circuit under test; the results are recorded in nepers in the United Kingdom.

This experimental equipment is not compatible with the automatic transmission measuring equipment in wide use in North America. The CCITT is continuing to study the question of automatic testing and it seems essential to agree internationally on the basic parameters of a set that will have universal application, even if it does present the results in North America in nepers.

### Digital techniques

In a period of slow growth, technical problems caused by the various incompatibilities were relatively simple to solve with universal FDM/AM techniques. The gap between practices of the Bell System and the European administrations has been narrowing over the years, and a large measure of standardization has been achieved. However, we are now faced with an unprecedented growth in demand for all types of telecommunication services, which is increasingly being met by digital techniques. There is grave danger that incompatibility is being built into national networks in the mistaken belief that new services will never become international or intercontinental.

**PCM systems.** Time-division multiplexes, pulse code modulation (PCM) systems designed for short-haul telephony are now in use or projected in various parts of the world. None of these systems could interwork without the use of audio interconnection or special interconnection devices.

Even the Bell T1 and the NEC systems could not interwork directly since in the former the 24 groups are sampled in two groups of 12 alternately, whereas in the latter system the 24 circuits are sampled sequentially. This of course can be overcome by rearrangement of wiring at the audio points, but nonstandard arrangements are always a hazard to overall system performance. In addition, the positioning of the signaling information would also involve terminal equipment changes.

**Integrated transmission and switching.** The difference between the Bell T1 and the U.K. systems is an example of how the differing states of development have influenced designers. In the United States, many T1 systems have been installed to meet pressing demands for circuits. In the United Kingdom, we have thus far been able to meet circuit demands by conventional FDM means, which has permitted consideration of the design of a PCM system that would also be compatible with an integrated switching and transmission plan. We believe that even greater economies can be achieved with digital switching although, in the Bell System, analog switching appears to be the accepted method for the immediate future. Again, much study is being undertaken by the CCITT, with a view to standardizing the essential parameters of PCM interfaces.

**Data and special services.** Digital links via communication satellite could prove a valuable addition to global communication facilities. Data links could readily be furnished, and as long as compatible PCM terminals were available, this might be an attractive means of providing multiple-access facilities, and perhaps the only way of providing intercontinental Picturephone service. Here, again, compatibility of Picturephone sys-



tems will have to be assured, but this seems difficult because of the 60- vs. 50-field-per-second problem.

### The future

The examples of incompatibility cited have been mainly from the line transmission field, but there are similar problems with radio transmission, telephone signaling, and operating. The countries that have 0 before 1 on their telephone dials have logic on their side, but this is little comfort when calling a subscriber in a country where 0 follows 9. It is all too easy for each country to choose its own in-band signaling frequency for its national network, only to find, many years later, that even if data transmission can be squeezed into the small frequency band between signaling frequencies, it is difficult to find an echo suppressor disabling frequency for universal application.

Most of the incompatibilities we have been considering can be resolved in two ways. We can remove the cause by standardization of essential parameters, or we can overcome the effect by technical ingenuity. Either method

involves cost and inconvenience. The former is obviously the ideal toward which we should strive, but because this takes time and effort, we have been forced to fall back on the latter.

In the past our technical ingenuity has enabled us to get by, but not without inconvenience to ourselves and our customers. However, there is always the danger that one day we will find that technical ingenuity is of no avail, and that suddenly a major international service that has been operating for many years will have to cease. It is becoming increasingly apparent that national systems should be considered an integral part of the whole global communications complex that we are now building, and we must stimulate in our designers an awareness of international as well as national needs.

Continuing compatibility in world communications must be assured, but this can only come if the good will and cooperation that has always been such a valuable feature of international communications is maintained and extended. We must, in the future, avoid the mistakes of the past.



## The role of Comsat in international communications

*Asher H. Ende* Federal Communications Commission

Whenever I deal with problems of compatibility as a lawyer, I envy engineers, because compatibility can be political, economic, social, or psychological, as well as technical. When a problem of technical compatibility arises, the engineer can study it, analyze the apparatus, build new equipment, and usually solve the problem. Lawyers and administrators, however, cannot dispose of incompatibility matters in communications quite so scientifically. In the social sciences there are no tools, formulas, conversion factors, or key phrases that enable us to eliminate a nontechnical incompatibility in the way that an engineer can depend on a piece of equipment.

Perhaps I can best illustrate the types of problems confronting the Federal Communications Commission in attempting to achieve nontechnical compatibility by reviewing what has faced us and what we have accomplished in the regulation of the activities of the Communications Satellite Corporation (Comsat).

### The creation of Comsat

Comsat in many ways represents a new departure in the common carrier communications field. It was created pursuant to a special act of Congress to plan, initiate, construct, own, manage, and operate, itself or in conjunction with foreign governments or business entities, a global commercial communications satellite system. It is a private corporation, but three of its directors are appointed by the President. It is given large responsibilities, including the right to enter into negotiations with any international or foreign entity regarding facil-

ities, operations, or services authorized by the Communications Satellite Act (CSA). It is also subject to comprehensive and thorough regulation as a communications common carrier. In this respect it is subject to all provisions of the Communications Act applicable to common carriers. In addition, under the CSA, it is subject to regulation as to procurement and finances, and a myriad of operating, rate-making, and technical matters by the FCC.

As we delve more deeply into the matter, we find that the complications multiply. Comsat is a publicly created private corporation that, hopefully, is to operate so that it will return a profit to the persons who invested in it. By law, up to one half of the stock is to be owned by the communications common carriers (telephone and telegraph companies) authorized by the FCC to invest in it. The other half of the stock is to be owned by the general public. The common carrier investors elect six of the fifteen directors, the public shareholders another six, and the President of the United States appoints the remaining three.

The theory underlying this corporate structure was to have diverse representation to give Comsat, a new corporation, the benefit of the expert knowledge and accumulated experience of the carriers and to have public representation on the Board. In practice, however, a series of difficult problems have arisen that have required great ingenuity to resolve. Thus, the carriers have a two-fold relationship with Comsat that encompasses interests that may be mutually inconsistent. As stockholders with

substantial investments, they naturally desire to maximize profits, to secure dividends, and to benefit from appreciation in stock values. As customers who lease capacity from Comsat to provide service to users, they are interested in the lowest possible prices and charges. Finally, as owners of other systems that can be used to supply service, and in other ways that I will discuss, they are competitors of Comsat.

### **Some major problems**

Under provisions of the CSA, Comsat alone, or one or more carriers, or Comsat and one or more carriers, may be licensed as the sole owner and operator of earth stations. Comsat had sought to be licensed as the sole owner and operator of all earth stations in the United States but one of the carriers suggested that the stations be owned jointly by Comsat and interested carriers on a 50/50 basis, and another carrier suggested that only the carriers should be licensed to own and operate such stations. These directly competitive claims provided the Commission with the first in a series of major problems. How is compatibility achieved when such divergent views are propounded? What converter is used? By what slide-rule can the opposing views be measured and balanced to determine which is right? The Commission adopted an interim policy under which Comsat would own and operate the initial three stations for two years, and it stated that at the expiration of that period it would review the matter on the basis of the experience gained and the situation as it then existed, and then adopt a permanent policy.

Another area in which a major problem has arisen is the so-called "authorized user" issue. It is clear, from the CSA, that Comsat was intended to serve primarily as a carrier's carrier—that is, to construct, install, and operate communications facilities to be leased to the interested common carrier, which would use them to provide service to the ultimate users. Note the word "primarily." The statute does not specifically state this to be its exclusive function. The act refers to "authorized carriers," "authorized users," and "authorized entities," and states that it is the intent of Congress that all authorized users shall have nondiscriminatory access to the system.

Here again the Commission is faced by directly conflicting and diametrically opposed claims and contentions. On one hand, large users claim the right of direct access to Comsat and object to being required to go to the carriers as "middlemen" who, they feel, could require that higher charges be paid than Comsat might ask. On the other hand, the carriers feel strongly that they should not be bypassed and point out that to the extent that they lose revenues for large-capacity services from relatively few customers, they may be required to increase rates to all other users to earn a fair return. The Commission is still considering this problem. Still another example of competition between Comsat and the carriers, whose nominees sit on its Board, relates to the use and ownership of facilities to provide needed services. We would welcome a device, invention, or piece of equipment that would insure us a compatibility between these divergent views.

If these matters give rise to difficult questions on how we can achieve compatibility, let me assure you that they are among the less complex. They involve only U.S. companies, which are subject to the same national

interest pressures, and the FCC is responsible for making decisions, as best it can, to resolve matters.

The real complications arise in the international field, where each nation enjoys sovereign rights, where goals often are neither identical nor even parallel, where needs differ drastically, and where barriers of distance and language exist. The problems that normally arise in this area were further complicated by the advent of satellite communications. Not only was it necessary to integrate a new means of communication into an existing and dynamically expanding system but, because of the nature of satellite communications, new structures had to be devised to exploit the new facilities effectively. The need for such structural development and the problems it presents tax the ingenuity of both communicators and diplomats.

In most countries, external telecommunication facilities are government owned and controlled, and the existing organizations were the ones originally designated to exploit the new means. In the United States, not only are external telecommunications facilities privately owned, but Comsat—a new and separate organization—had been created to exploit satellite communications. This fact alone presented difficult problems.

In general, international agreements on telecommunications facilities and operations, as far as the United States is concerned, usually are bilateral and private; each company makes its own arrangements with the operating entity in each foreign country with which it communicates. It soon became apparent that such a procedure would not be acceptable to most countries with regard to satellite communications. They felt that there must be intergovernmental agreements. A problem of compatibility arose here, since by law Comsat is a private corporation.

### **A unique solution**

The dilemma was resolved by negotiating two sets of agreements. A basic agreement set forth the general principles for the planning, construction, and operation of the global satellite system. A second agreement delineated the more detailed provisions for the operation of the system. This agreement was signed by operating entities designated by each government in their corporate rather than official capacities. Comsat was named the U.S.-designated entity and signed the agreements in that capacity. Thus, compatibility was achieved.

Of course, the mere adoption of a "two-separate-agreements" approach did not resolve all the problems involved. Before agreement was finally reached, many substantive problems had to be considered. They included questions of how ownership shares should be divided; how control should be exercised over the consortium; what vote or voice each owner should have; how rates were to be fixed; the total investment; terms of accession; method of payment for shares and for use of the system; whether nonmember countries should be given access to the system, and if so, on what terms; and the terms and conditions under which procurements should be made for the system, and how nations without the necessary "know-how" could share in the results of the research carried on, in part, with their funds.

Each of these problems was resolved in a manner that duly recognized the interests of the various nations, and the acceptability of the agreement is demonstrated by the

number of nations that have joined—48 are members and several others are applying for membership. These countries represent 90 percent of total international traffic. This support is particularly gratifying because although most of the countries do not have or plan to have earth terminals for some years to come, they have invested substantial sums in the space segment.

### **Comsat's triple role**

As usually happens, the solution of one series of problems gives rise to another series. In this case, the creation of an international consortium required the United States to focus upon the relationships between government and Comsat and between Comsat and its partners in the consortium. As I pointed out earlier, Comsat is subject to more regulatory supervision than any other communications common carrier. However, after the signing of the international agreements, it became almost a triple personality. It continued as a U.S. common carrier subject to the applicable statutes. It is also the U.S.-designated entity in the consortium. Finally, it is the manager of the space segment of the satellite system on behalf of all members of the consortium. Although its functions in the three roles are not inconsistent, its status, what it is to do, and the nature of its obligations in each role are different. In its third role, it is an agent for all the members and reflects and executes the consensus of views, which as a member it helps formulate.

Drawing a line between the things Comsat does as a carrier, as the U.S. representative, and as manager of Intelsat is a delicate art in which there are no masters. Thus far, the FCC has resolved problems in such a way as to accommodate the legitimate interests of all and to avoid narrow or bureaucratic positions. This is possible only to the extent that there is mutual respect and a sincere desire to cooperate in order to find solutions that recognize the legitimate interests of the agencies of the U.S. government, members of the consortium, and Comsat.

The types of problems that arise and how the FCC is resolving one of them can be illustrated by the following example. It relates to the application of the FCC procurement rules to procurement for the space segment owned by the consortium. The Communications Satellite Act requires that this agency establish such rules as are necessary to "insure effective competition, including the use of competitive bidding where appropriate, in the procurement by the corporation and communications carriers of apparatus, equipment, and services required for the establishment and operation of the communications satellite system and satellite terminal stations." In accordance with this requirement and after going through its normal rule-making processes, on January 8, 1964, the Commission adopted specific procurement rules that apply to all procurements above \$25 000 by Comsat or other carriers of apparatus, equipment, and services for the establishment and operation of the space segment and earth stations of the satellite system. Certain exceptions apply, e.g., governmental arrangements for satellite launching.

These rules were adopted some six months before the interim agreements establishing the international consortium were originally signed in August 1964, and applied to both procurements in the United States and

abroad. The agreements also embody rules that parallel the FCC rules and seek to achieve the same objectives while taking into account the interests of members of the consortium in sharing in the provision of facilities, equipment, and services to the space segment. However, questions have been raised as to whether it was appropriate to have rules of a U.S. agency applicable to procurements made abroad for a system jointly owned by some 48 nations. Accordingly, after receiving a proposal from Comsat, the Commission issued a notice soliciting comments on amendments to the rules designed to accommodate the statutory requirements imposed on the FCC and the legitimate interests of the members of the consortium in this respect. The proposed rules would make FCC regulations expressly applicable only to entities subject to U.S. jurisdiction as far as procurement for the jointly owned space segment is concerned. The interim agreements and domestic law in each country would control procurements made abroad.

In other fields of mutual concern, such as rate making and determination of characteristics of earth stations, the responsible U.S. government agencies have concentrated on the formulation of positions that could be presented as the United States contribution to the deliberations of the consortium and have addressed themselves to Comsat as the U.S. corporation rather than as manager for the consortium.

### **The progress made**

In outlining the problems resulting from Comsat's various relationships with the FCC and other U.S. international carriers, as well as Comsat's responsibilities as the U.S.-designated entity in the consortium and its relationships with foreign telecommunication entities, my purpose has not been to point out conflict or discord, but to stress two things. First, we are confronted with unique and difficult problems in the satellite field not only in developing equipment, but also in formulating a basis for a global consortium. Second, we have made substantial progress, considering the pitfalls that surrounded us and the difficulties we had to surmount. In fact, the remarkable thing is the amount of progress made in less than two years in laying the foundations for a widely accepted system of global communications. We have achieved a miracle in technical, political, social, and economic compatibility in an environment of enlightened cooperation among nations in a project to provide mankind with a new technique for communication.

The Early Bird satellites are now in commercial operation, and new satellites with many times their capacity are being designed. In the not too distant future, the consortium should be able to offer services to the nations of the world via satellites designed to handle all types of traffic, including television, aeronautical radio, high-speed data, voice telephone, and all types of record service. Ground stations are now under construction or being planned in more than a score of countries.

Engineers have given the world a technical capacity to do marvelous things; it is up to the lawyers and the politicians to assure that these technological accomplishments can be enjoyed in a world of peace, international understanding, and cooperation. Perhaps the progress they have attained so far, as outlined here, will provide some indication of what they are trying to do.



# U.S. military worldwide communications

James H. Weiner *Defense Communications Agency*

The United States, as well as being a full member of the United Nations, has diplomatic relations with more than 100 different countries, mutual defense treaties with more than 40 nations, and regional treaty commitments on every continent. In all our relations with foreign nations, common policies must be made and executed with full appreciation of the dynamics of the international scene. The problem of coordinating and integrating the total power of the United States may be our most important national challenge.

The U.S. worldwide military communications system, in addition to serving military requirements, also contributes significantly to support other U.S. commitments. One of the major demands upon this system stems from the requirement to provide our National Command Authority with timely information on current events as a basis for decision, and to transmit policy decisions of the Authority to the appropriate military commanders to produce the controlled military reactions desired. Modern weapons technology dictates an overriding need for adequate dependable communications that do not degrade the reporting of information or introduce ambiguities or delay in the dissemination of executive decision. Controlled response in the nuclear age is impossible without effective communications.

In support of our national policies, the organization of communications resources to accommodate the diversity of users in a wide range of situations poses a major challenge to the communications engineer. The defense communications system consists of some 33 000 circuits, composed of more than 138 000 channels covering about 24 million miles interconnecting in 96 countries. A large portion of these facilities is leased from U.S. systems. The annual leased cost of transmission channels alone approaches \$127 million. The military-owned fixed-plant investment is approximately \$2.5 billion, and the annual operating cost is some \$700 million; this is just the long-lines portion of the system and does not include military, mobile, tactical, and some special-purpose communications equipment.

Installation of two worldwide automatic networks is now under way. One, for voice, will use automatic electronic switches and provide direct distance dialing between U.S. military forces throughout the world. In addition, special features such as multiple-level preemption, off-hook and abbreviated dialing, preset conferencing, and automatic alternate routing are provided. The other system is designed for teletypewriter and data traffic. It will use high-speed transmission, code and speed conversion to meet individual user requirements, multilevel precedence, and automatic error detection and correction. Both systems are fully automatic, using computers to replace human operators. Installation will be completed by 1970.

## Typical circuits

Every known electrical communications medium is used in support of this system. To insure effective transmission performance, extensive detailed engineering is required. For example, incompatibilities exist in such areas as signaling, facilities performance, and supervision. All of these must be considered in the course of circuit engineering without regard to the number of interconnected modes. I will not discuss the finite transmission engineering required to produce high-quality, user-to-user circuits, but a brief description of some of the routings will indicate the magnitude of the task.

One circuit runs from Colorado to a terminal facility approximately 7000 miles distant in the Canadian North. At the U.S. end, the circuit terminates in teletypewriter machines at three locations. The circuit routing is via U.S. commercial leased facilities through Denver, Kansas City, and Detroit. It then interconnects with Bell Telephone of Canada through Toronto and Montreal to Goose Bay, Labrador. The U.S. military-owned facilities are then employed for the remaining portion of the route. The media used include a land-line cable, microwave, and tropospheric scatter radio.

Another interesting circuit, a direct-voice circuit and the longest known, is from Washington, D.C., to Saigon—a distance of over 11 000 miles. The facilities of commercial carriers are employed across the West Coast cablehead, then on to Hawaii via submarine cable. The Hawaii-to-Philippines link is via commercial submarine cable with an alternate capability through the facilities of the SYCOM III satellite. In the Philippines the circuit is routed over a U.S. government-owned submarine cable to Nha Trang, Vietnam. The circuit is extended to Saigon by tropo scatter radio and land line.

Common performance objectives, common standards, and compatibilities are an absolute necessity if circuits of this type are to provide high-quality, efficient, reliable communications. The Defense Communications Agency (DCA), the long-lines manager of U.S. military communications, provides communications service, and that service may be required between any two points on the earth. Under such conditions, a circuit often crosses several international boundaries. Availability of installed facilities is immaterial; even ownership of these facilities does not really matter. What does matter is performance. To have circuit performance we must have standards for both equipment and circuits that insure compatibility between interfacing equipments.

The U.S. Military System Standards are somewhat more stringent than the accepted CCITT and CCIR standards. However, in most cases the latter are adequate for our purposes, but many of the older systems do not as yet meet even these standards. We often find incompatibilities in signaling, performance, and supervision.

## The satellite program

Many new techniques now being developed will permit us to make major improvements in global communications. Of these, none is more promising than the satellites. During the post-Korean era it had become increasingly apparent that the U.S. military conventional long-lines communications media were inadequate in terms of existing and projected requirements. A communications satellite system appeared to offer the greatest promise of providing certain characteristics that were not available with other existing communications systems. Characteristics desired were more survivability, invulnerability, better reliability, greater world coverage, enhanced flexibility, and security with a potential for future growth.

In 1962 the Secretary of Defense created the Defense Communications Satellite Program (DCSP) and made it the responsibility of the DCA. The objective of this program is "to develop the technology required for an operational system in a timely manner."

Phase 1, SYCOM, began as an experiment to determine the feasibility of using a synchronous satellite for communications and of changing and maintaining an orbit of a synchronous satellite. These initial objectives were successfully demonstrated and the system is now being used for additional testing and to provide a limited emergency communications capability in the Pacific and Indian Oceans. Circuits are operating between Hawaii and Southeast Asia and between the Philippines and Asmara. Experimental earth sets have been successfully sea-tested, and the ranges have satisfactorily approached the maximum practicable between earth terminals.

The second phase of our program is the Initial Defense Communications Satellite Project. Earth terminals have been deployed and are now awaiting launch of the satellites. The objectives of this phase are: (1) to conduct research, development, test, and evaluation for the purpose of demonstrating system operational feasibility; (2) to obtain an emergency capability as early as possible; (3) to establish a research and development system that can be converted to an operational one.

The initial system will consist of from 15 to 22 satellites in a quasi-synchronous orbit forming a belt above the equator, and will utilize fixed, mobile, transportable, and shipboard terminals. After some nine months of testing, the system will provide a limited operational capability. The satellites to be launched will be injected into orbit from the booster transtage in sequence. Each satellite will receive a different velocity imparted by an increase in thrust of the transtage during the ejection period, causing them to spread in a random distribution around the world on the equatorial plane. Each satellite will be spin-stabilized, and will have a nominal output of three watts with two voice channels and two teletypewriter channels.

The ground environment of the IDCSP will consist of several newly developed terminals and modified terminals previously built for other programs. The modified stations are AN/FSC-9's, which are 60-foot antenna installations at Fort Dix, N.J., and Camp Roberts, Calif. These terminals had been used as part of the ground system supporting SYCOM.

Seven improved lightweight shipboard sets are due for delivery to the Navy during 1966. They will have increased performance, reliability, a higher frequency selection,

and a pedestal four times lighter in weight than the original. This last is very important for it permits installation of a six-foot antenna atop a ship's mast for an unobstructed view in all directions.

The third phase of the DCSP is the Advanced Defense Communications Satellite Project, designed to provide a truly operational system to meet the unique and vital command and control communications requirements of the Department of Defense. The project will be utilized to furnish high-quality trunking between switches and/or direct user-to-user circuits between major command elements. It will provide a worldwide system capable of serving fixed installations, newly deployed forces on a contingency basis, naval ships afloat, and, later, aircraft.

To the extent that we are successful in learning how to increase satellite reliability, sensitivity, and usefully radiated power levels, we will be encouraged to reduce the size, complexity, and cost of our surface and near-surface terminals. This will broaden the application of satellite circuits to the solution of many communications problems other than those of the long-distance point-to-point variety.

## Some other changes

In addition to operational satellite systems, other major changes are being introduced into our communications networks. To understand these changes we must understand the changing requirements. What are these needs and how are they changing? With increasing centralization of management and the necessity to minimize time required to develop controlled responses, information in more detail will be needed and must be transferred at higher transmission rates. Large volumes of data must be transmitted in near real time from any place to any other place in the world. The variety of terminal devices is rapidly increasing, with an attendant impact on transmission and switching.

To satisfy these requirements our communications systems are expanding rapidly and are undergoing major changes. Newly developed digital transmission systems are being introduced. Medium bandwidth is giving way to extremely wide-band systems with an accompanying better utilization of bandwidth. Communications systems are evolving into "hybrid" systems or combinations of frequency division and time division multiplexing. We are moving into an era of complete electronic automated switching. We are constantly adding more interconnected points between our local and national systems in order to provide a worldwide operational system. The increased use of data implies a need for great accuracy. There will be a need for improvement not only in transmission error rates, but in the efficiency of systems utilized in error reduction in order not to degrade the transfer capacity of the systems. Finally, the users of our communications systems are demanding these services at a greatly reduced cost.

I shall not attempt to describe these systems of the future. The ramifications are many and extend into all areas of our worldwide communications community. We are making progress, but it is slow and often sporadic. More effort is required. We must re-examine our present concepts. If they are the same as we had a few years ago, we are in trouble. Technologies have changed, problems are different, demands are new, and opportunities are here.

Human society's total energy requirements are growing at an explosive rate, since both population and per capita energy consumption are increasing rapidly. It is suggested in this article that the most effective long-range solution to future supply and distribution problems will involve the use of both primary (or continuously supplied) energy and secondary (or stored) energy, with the latter playing an increasingly important role.

Energy, in the broadest sense, is one of mankind's most pressing needs. It is required by human society for two main purposes: (1) as food for human consumption and (2) as a means for powering the social economy, in both mobile and stationary installations. This article is concerned chiefly with energy for the second purpose, which may be thought of as "inanimate" energy.

In the final analysis, all energy must be derived from the primary sources found in nature, which may be summarized as follows:

1. Solar energy, utilized
  - a. directly, as for space or process heating or to produce electricity, as by means of photocells
  - b. via the photosynthesis process to produce food, combustible vegetable matter, and fossil fuels
  - c. to produce wind power
  - d. to produce precipitation hydraulic power
2. Tidal hydraulic power
3. Geothermal power
4. Chemical energy not involving combustion
5. Nuclear energy—fission and fusion

Human demands for energy may be roughly summarized as shown in Table I. Present figures are based on a world population of 3 billion and actual world consumption of inanimate energy. It should be stressed that the per capita figures are averages; in the most technologically advanced countries, the per capita inanimate energy consumption is more than 12 times this amount. The per capita food requirement is based on 3000 calories per day, which is equivalent to about 1/7 kW continuously per person. Projected figures for the future are for a world population of 35 billion (one person per acre) and estimated energy requirements when the population reaches that figure. Note that the food-energy percentage of the total drops from the present 20 percent to about 1 percent.

#### Solar radiation

Where will this energy come from? Superficially there appears to be no problem, because it amounts to less than 0.3 of 1 percent of the 171.6 trillion kilowatts of solar radiation intercepted by the earth continuously. This is an oversimplification, however, because only 42 percent of the intercepted energy reaches the surface of the earth—of which only 28.4 percent is land. But the average intensity of solar radiation would be capable of supporting one person per acre—or a human population of 35 billion—at a high standard of living, from solar radiation alone, even neglecting the 71.6 percent of solar radiation that

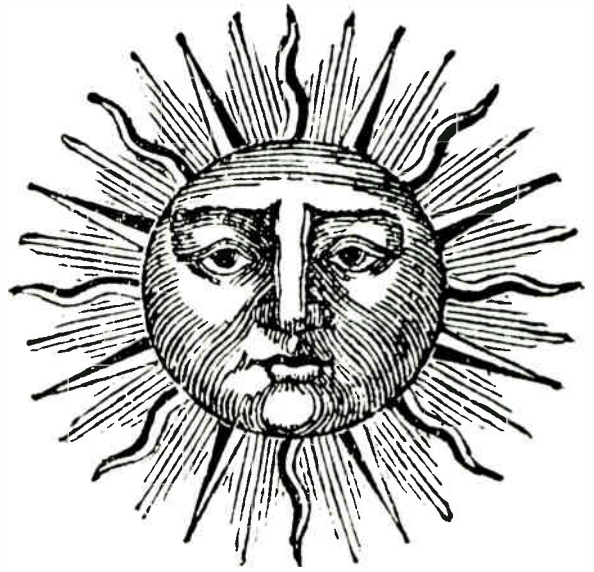

## The future of energy supply

*In spite of tremendous projected future needs in the world economy, the basic natural sources of energy should be more than adequate. The real problem lies in providing energy continuously and economically in the forms required*

B. C. Hicks *Hydro-Québec*

falls on the oceans, if an average efficiency of only 2.5 percent could be achieved in converting solar radiation to human uses on the land surfaces of the earth.

The word "average" conceals a joker, however, because solar radiation is neither continuous nor uniform over the surface of the earth; moreover, society requires not merely crude, undifferentiated, energy in anonymous bulk but energy available for immediate utilization when and where needed, and in the forms and quantities required by those who will use it. Food energy illustrates this point very well.

It has been estimated that photosynthesis produces 150 billion tons of organic carbon per year, equivalent in energy content to 0.1 percent of all solar radiation intercepted by the earth. This represents the food energy, at 3000 calories per person per day, required to sustain about

one trillion human beings. The difficulty is that this material is not all available where needed and in forms suitable for human consumption. Even if it were, it could not all be devoted to feeding human beings. The inescapable fact is that the balance of nature must be maintained, a fact that we are sometimes prone to forget. Consequently, there is already growing concern about the earth's ability to adequately support a greatly increased human population without the grave risk of dangerously disturbing and polluting the human environment.

The foregoing considerations indicate that photosynthesis could, at best, supply less than one third of the possible ultimate energy requirements of humanity. Actually, even today, photosynthesis provides the economy with little more in the way of energy than food; fossil fuels are the major source of inanimate energy. The fact that these fossil fuels are exhaustible calls for an examination of the potentialities of the other primary sources of energy.

In the long-range future, hydraulic sources can provide only a small proportion of all inanimate energy requirements, possibly only 1 percent or less. As we have already seen, solar radiation falling on the land surface could satisfy all requirements if conversion could be effected at an average efficiency of 2.5 percent, but the technology for accomplishing this conversion does not exist today. If it did exist, the cost would be prohibitive; moreover, the balance of nature would probably be upset. Wind power is equivalent, approximately, to all requirements, but it would probably be impracticable to develop more than a small percentage of the total amount and the cost would, in general, be high. Geothermal power is still a largely unknown quantity and chemical energy would seem to be impractical for cost, and other, reasons. The hope of the future, therefore, rests largely on nuclear energy.

Regardless of how the demands for energy are satisfied, it would appear that resources are available to satisfy them. The question, then, is whether the resources can be applied in the ways required. As already noted, inanimate energy is utilized in two broadly general ways, namely, in stationary and mobile installations.

### Primary energy sources

In general, all of the primary energy sources can be developed in stationary installations but not so in mobile installations; for example, hydraulic sources are not directly applicable to motor vehicles. In fact, the only primary sources highly practicable for direct use in mobile installations are the fossil fuels. Nuclear energy has been considered, but it appears to be out of the question, chiefly because the cost would be more than a thousand times as great as with fossil fuels.

Even in stationary installations there are limitations on the application of primary energy sources. An important one is that of size. A large hydraulic site must be developed as a unit, and, from another point of view, there is usually an economic advantage in developing primary energy sources in large blocks. In the case of nuclear

energy, for example, a 600-MW plant might cost \$110 per kilowatt, whereas a 25-watt plant would cost \$2.5 million per kilowatt.

Although there are cogent reasons for developing primary energy in large blocks, most consumers require energy only in small quantities. This situation has led to the practice of developing primary energy in large central stations, converting it into electricity, and distributing the electricity from a relatively small number of interconnected central stations to a large number of consumers scattered over an extended geographical area.

The major weakness of this form of energy supply is that it is subject to widespread, and perhaps prolonged, power blackouts, which can cause great loss and inconvenience to individuals and to the community at large.

One means of overcoming this weakness is to abandon the electric power system altogether and resort to isolated generation on the premises of all consumers. What this alternative involves is the physical transport of energy in containers to the consumer's premises, for development there. This practice would put stationary installations on a par with mobile installations and tend to restrict the choice of primary energy sources largely to the fossil fuels, which would constitute only a temporary solution of the problem since it would hasten the exhaustion of the fossil fuels. Then a permanent solution would have to be found.

### Secondary energy sources

Insofar as it is true that primary energy sources can only, or most advantageously, be developed in large blocks, a time is bound to come when a substitute for the fossil fuels will be needed. At present, it would appear that this must be secondary energy produced from primary energy sources.

The distinction between primary and secondary energy sources is quite relative and somewhat arbitrary. For example, solar radiation originates from a nuclear reaction on the sun and in that sense might be considered to be a secondary source of energy. Similarly, wind power, precipitation hydraulic power, and vegetable and fossil fuels originate from solar radiation and in that sense might be considered to be tertiary sources of energy. Disregarding these refinements of nomenclature, however, it seems preferable to revert to the original thinking that, long ago, established the terms primary cell (e.g., dry cell) and secondary cell (e.g., storage cell). In conformity therewith, energy that flows continuously from any of the natural

### I. Human demands for energy

	Per Capita Energy, kW		Total Energy, billion kW	
	Present	Future	Present	Future
Food	0.143	0.143	0.43	5.0
Inanimate energy	0.667	14.26	2.00	500.0
Total energy	0.810	14.40	2.43	505.0

sources directly to final utilization—even if complex conversions, such as from fuel to heat, to steam, to mechanical power, to electricity, are involved—is considered to be primary energy. When the continuous flow from a primary source to final utilization is interrupted by any form of intermediate storage that introduces a delay in final utilization, the storage device is considered to be a secondary energy source, regardless of whether it is a storage battery, pumped storage, a chemical element or compound produced from a primary energy source and capable of storing energy for later utilization, air compressed and stored for later use, or anything else of a fundamentally similar nature.

It is pertinent at this point to ask whether there is any long-range alternative to converting primary energy to secondary forms for physical transportation to the site of utilization. In this connection the practice, long established for essential services, of combining normal load supply from the power system with emergency supply from energy stored on the premises (e.g., in storage batteries) should receive consideration. Here the power system brings all energy to the consumer in the form of electricity, and storage takes place, on the premises of the consumer, in a secondary form; no physical transport is required. This technique of retaining the power system as the basic means of energy supply to the consumer and combining it with local storage of secondary energy on the premises of the consumer makes possible the direct use of primary energy under all normal conditions and provides a dual supply to reduce the risk of service interruptions in emergencies.

At the moment there appears to be no alternative to the increasing use of secondary energy. When the fossil fuels are exhausted, secondary energy must unavoidably be resorted to for powering mobile installations and, as the economy becomes more and more dependent on inanimate energy in stationary installations, secondary energy will be increasingly necessary to provide assurance of uninterrupted energy supply.

The question of secondary energy supply for mobile installations is already the subject of much study, two major lines of investigation being the improvement of storage batteries and the development of fuel cells for use in electrically propelled vehicles. It seems reasonable to assume that whatever substitute is found for the use of fossil fuels in motor vehicles will be equally applicable as secondary energy sources in stationary installations.

The energy supply system suggested herein involves (1) the development of primary energy sources in large central stations; (2) conversion of primary to secondary energy for delivery to mobile installations; (3) delivery of primary energy to stationary installations by means of the electric power system; and (4) utilization of this primary energy on the premises of the consumer either directly in the utilization devices or via a secondary-energy-storage system, to serve as a buffer between the power system proper and the utilization devices, the purpose of the intermediate storage being to provide assurance of a continuous energy supply. A system of this type would, of course, require optimization to provide maximum net benefits to the community at large.

#### **Energy storage**

In any attempt to optimize the proposed system it must be recognized that energy storage is an essential part of

practically any energy supply system. Food must be stored to last from one harvest to the next, water must be impounded in reservoirs to develop hydraulic power, solar energy must be stored in some form that can be drawn on when the sun is not shining, etc. It should also be recognized that the greatest assurance of energy being available when required is obtained when storage takes place locally, on the premises of the consumer. An important consideration in system optimization is the amount of secondary storage that can be justified on the premises of individual consumers, keeping in mind that the more storage there is at this point the less there will be required on the power system proper.

If the idea of local secondary energy storage is oriented solely toward providing emergency supply in the event of a power system blackout, the cost of the facilities must be justified solely on the basis of avoiding the loss and inconvenience occasioned by power blackouts. This would mean that there would be minimum use of the facilities and, as a result, a relatively high unit cost for the benefits they provide. If the sights are raised, however, it will be seen that with increased local storage, the peak capacity on the power system proper can be reduced, the annual utilization factor of power system equipment can be improved, the load factor on the power system proper can be made to approach 100 percent, the power losses can be reduced, the voltage can be made more nearly constant, and the storage on the power system proper can be reduced.

Concerning storage on the power system proper, it is worth noting that usually intermittent sources of primary energy (such as tidal energy, for example) require “firming up” if they are to become highly practical. This can be achieved in a variety of ways. If tidal power is integrated with precipitation hydraulic power, inherent firming exists to the extent that water can be stored in precipitation reservoirs when tidal power is available for later use when the tidal power is not available. If necessary, pumped storage can be added; but local storage of secondary energy on the consumer’s premises can partly or completely replace pumped storage to firm up tidal power. Although this practice would tend to reduce the load factor on the power system proper, there would be the advantage that hydraulic power produces no pollution and is not subject to depletion.

#### **Conclusion**

The basic problem in connection with the future supply of energy is not that the energy resources are inadequate; rather, the problem is one of finding ways to make energy continuously available in the forms needed. It is suggested that this requirement calls for a marriage of primary and secondary energy—that is, the use of secondary energy in mobile installations and the optimum use of both primary and secondary energy in stationary installations, with virtually all energy for stationary installations being delivered to the premises of the consumer via the electric power system.

With society’s increasing dependence on inanimate energy, continuous energy supply is becoming more and more imperative and it is perhaps utopian to expect that any single, simple expedient will be found. It should be possible, however, to achieve the desired end by combining with the electric power system a rational conception of the use of primary and secondary energy.



# Industrial radio telemetry

*Radio telemetry is being employed in many industrial applications when it is not possible or desirable to use a conductor for carrying data or commands. New devices and techniques have contributed to the rapid advances being made in this field*

*C. H. Hoepfner Industrial Electronics Corporation*

**Industry is turning to new techniques for measuring physical quantities at relatively inaccessible locations and reading or recording them from a convenient distance. Because the distances are relatively short and transmission techniques over the radio link are inefficient, the equipment is less elaborate and costly than in space telemetry. But industrial environments and technical operating skills require most telemetry system components to be far more rugged, capable of accurate measurement with only the simplest calibration techniques.**

The deeper an instrumented vehicle probes into the remote reaches of outer space, the more technologically spectacular seem the achievements of telemetry. There is still something exciting and uncanny about performing measurements of a physical quantity at a distant location and precisely reproducing them at a more convenient place for reading or recording them.

Yet the vast distances spanned by telemetry signals are less challenging technically than the stubborn problems of inaccessibility to quantities being measured. Signals from a missile-launched space probe soaring toward the sun are often easier to obtain than measurements from inside a stolid, earthbound motor only a foot away.

The technology that has produced missile and space telemetry is also spawning new forms of industrial radio telemetry, capitalizing on the development of new transducers, powerful miniature radio transmitters, improved self-contained power sources, and better techniques of environmental protection.

Simply expressed, to telemeter is to measure at a distance. First, at the remote point, you need a transducer, a device that converts the physical quantity being measured into a signal, usually an electrical one, so that it can be more conveniently transmitted. Then you need a connecting link between the location where the measurement is being made and the point where you can read or record the signal being sent. This link can be an electrical circuit (there have been wired telemetry systems since long before the turn of the century), pneumatic or hydraulic lines, a beam of light, or a radio carrier for frequency or pulsed systems of measurements. Essentially, a subcarrier is needed to impress the measurement signal on the carrier, a transmitter to generate the carrier, a receiver to pluck the carrier out of the air and reproduce the measurement signal, and a meter or recorder to display the measured quantity.

The radio link can transmit an analog of the continuous variable being measured; or, with pulse code methods, it sends the measurement data digitally as a finite number of symbols representing a finite number of possible values of the measurement signal at the time it is sampled. In this case it is necessary to encode the signal before it is transmitted, decode it after it is received, and maintain synchronism between the encoder and the decoder. Despite the complexity these processes add to the equipment, digital data are not easily degraded by noise and nonlinearities in the transmission link.

The range of a radio link is limited by the power radiated from the transmitter toward the receiver and by the sensitivity of the receiver. A 10- $\mu$ W output will transmit data easily 100 feet with a bandwidth of 100 kHz. The wider the bandwidth, the greater will be the effect from noise, and therefore the greater the transmitted power required for a detectable signal.

At the receiving station, of course, it's usually a simple matter to provide large antennas, sensitive radio tuners and recorders, and an ample power supply. But the transmitting station must be quite small, usually doughnut size but sometimes no bigger than a pea, and must be self-sufficient—carrying its own power or perhaps receiving power by radio.

## **Trading inefficiency for reliability**

On the surface, industrial radio telemetry seems to be simply a matter of hardware. And it almost is, except that the functional requirements are considerably different from what one has come to expect of missile and space telemetry. Distances are short, a few feet to a few hundred yards, so signal power can be radiated directly from the transmitter circuitry or from a simple antenna; and most tests are repeatable.

Quantities can be measured one or two at a time, in contrast to the simultaneous transmission of enormous amounts of information. Although relatively inefficient use of the radio link results, much simpler circuitry can be used at both the transmitting and receiving ends.

Surprisingly, environment plays the most critical role in industrial telemetry. It marks by far the largest difference between telemetry operations from missiles and spacecraft and telemetry for industrial remote measurement. Whereas missile telemetry equipment is expected to withstand accelerations of 10 to 20 *g*, the rotating applications of telemetry in industry require immunity to 10 000 or 20 000 *g* centrifugal accelerations.

Unlike missile telemetry equipment, which is insulated against extremes of temperature and against shock and vibrations, and which is carefully calibrated for weeks before it is used only once in an actual shot, industrial telemeters must operate repeatedly without adjustment and calibration. Used outdoors, they are often subjected to a temperature range of  $-40^{\circ}$  to  $+60^{\circ}\text{C}$ . They must operate when immersed in hot or cold fluid, and thus it is almost mandatory that they be completely encapsulated to be impervious not only to humidity and water but to many other chemical fluids and fumes. Many lubricating oils operate at temperatures of  $150^{\circ}$  to  $180^{\circ}\text{C}$ .

Although missile telemetry components had to be made small and light, an order of magnitude reduction in size and weight has been necessary to make them suitable for high-speed rotating shafts or for biological implants. They must be so reliable that no maintenance is required, for there are no service centers set up to handle this kind of equipment, which must work without failure if it is to continue to gain industrial acceptance.

Fortunately, the inefficiencies permitted in industrial telemetry make for less elaborate, less costly equipment. Radio channels are used in a relatively inefficient manner and the distances between transmitter and receiver are usually so short that there are few problems of weak signals reaching so far as to become unauthorized radiation from the telemetry equipment. In many cases, measurement and testing via telemetry links take place in completely shielded buildings or in metal housings.

Though it is usually defined as measurement at a distance, telemetry has gradually begun to embody the concept of control from a distance, too. In a telemeter—the transmission of the value of a quantity from a remote point—it may only be necessary to observe the reading of an instrument to determine the temperature, pressure, or vibration of a distant or inaccessible object. But the output of the instrument can also be fed into a control mechanism, such as a relay or an alarm device, so that the telemetered signal may activate or stop a controllable process. Measurement may be made at one location, indication provided at another, and the remote control function initiated at either location, or even at a third.

Take, for example, an oil pipeline in which a motor is pumping oil from one location and oil pressure is being measured at a second location. The pressure reading is telemetered to a station, where a decision can be made to reduce the speed of the pump motor when the pressure is too high. Or a valve may be opened at another location to cause the oil to flow in another path. The decision-making element may be a man or an automatic controller.

### Measuring and transmitting

Telemetry, then, really begins with measurement. A physical quantity is converted to a signal for transmission to another point. The transducer that converts the physical quantity into an electrical signal typically may be a piezoelectric crystal, a variable resistance, or perhaps an accelerometer.

Telemetering the measurement signal of the best transducers in no way degrades the measurement below accuracies attainable under laboratory conditions. For instance, in strain measurement it is possible to achieve accuracies of a few microinches per inch or greater. But the limitation is usually the degree of stability in the bond of the strain gage to the specimen.

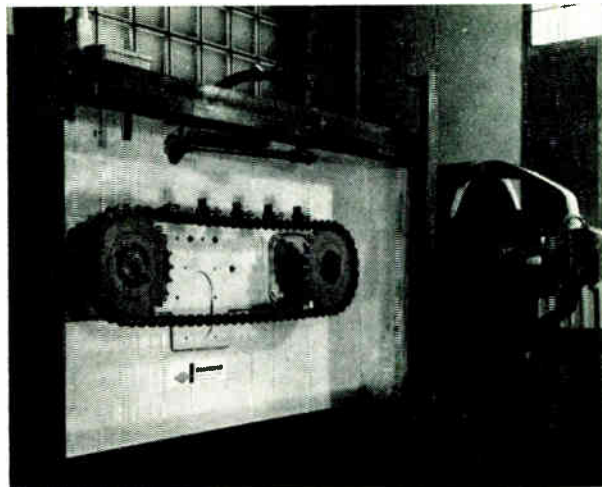

Chain tension testing with four telemeters.

Accuracy in temperature measurement can be attained by choosing a transducer that provides a large variation in output signal over a small range of temperature. The resolution provided may be translated to true accuracy by careful transducer calibration. Accuracy is reduced, of course, over a wider range of temperature. Typical analog telemetry links maintain a measurement accuracy on a single channel between one and five percent. But this is not a limitation of the total system since one percent of a  $100$ -degree temperature change would only be one degree, so several telemetry channels can easily share the total temperature range to be measured—say a  $100^{\circ}$  range divided into four  $25^{\circ}$  ranges to produce an accuracy of  $\frac{1}{4}\%$ .

One of the limitations to accuracy and repeatability in telemetry is the output level of the transducer. The low electrical levels produced by thermocouples and strain gages ( $0.01$  volt) are much more difficult to telemeter than high-voltage levels of  $5$  volts. At low signal levels, extraneous electrical noises produce greater degradation. These may be thermally generated, or caused by atmospheric effects, or generated by nearby electric equipment. When low-level transducers are used, stable amplifiers must raise their signal voltage to useful modulation levels.

### Modulating and multiplexing

The transducer signal modulates the frequency of the subcarrier oscillator. This oscillator is simply a resonant circuit that produces a given frequency in the audio range, say  $1000$  Hz, and is varied above or below this center frequency by the signal from the transducer as it responds to the variable being measured. If the signal were fed to a loudspeaker, one could actually hear a rising or falling tone. The subcarrier oscillator modulates an RF carrier, varying its frequency or its amplitude in accordance with the subcarrier voltage signal. The radio frequency in FM industrial radio telemetry links is usually in the  $88$ - to  $108$ -MHz band, and thus high-grade radio tuners already mass-produced for the high-fidelity market can be used. At the other end of the link, the radio receiver demodulates the signal, removing the carrier and feeding it to a special discriminator circuit that removes the double modulation and precisely reproduces the original meas-

urement signal for calibrated indication or recording.

There can be great variations in the strength of the radio signal received because of variations in distance between transmitter and receiver, or because of the interposition of metallic objects. In industrial radio telemetry transmission, these effects are prevented from disturbing the data by resorting to frequency modulation of both the subcarrier and the carrier so that the telemetered signal is unchanged by undesirable amplitude variations. This method is called FM/FM telemetry. Other methods of carrier modulation include pulse amplitude modulation, phase modulation, pulse duration modulation, etc. Each of these has its proper place in missile and space telemetry, where great distances must be spanned with a maximum of data over crowded and often noisy communication channels. Pulse code modulation of an FM link may be expected to become more widespread in industrial telemetry applications as well.

It is important, particularly in missile telemetry, that multiple measurements be transmitted over a single carrier to save power and minimize electronic equipment and antennas. Such simultaneous transmission of signals over a common path, called multiplexing, is sometimes used in industrial telemetry. When concurrent data about several simultaneous events are transmitted by several subcarriers, each subcarrier oscillator has a distinctive reference frequency, from which it swings toward arbitrary maximum and minimum frequencies in response to signals from a corresponding transducer. Thus a number of separate audio-frequency bands are sent over the radio-frequency carrier. This is called frequency-division multiplexing, a technique that requires careful adjustment of subcarrier frequencies and the corresponding filters at the receiver, and strong suppression of harmonics to avoid crosstalk or interaction between channels.

Multiple measurements may also be transmitted over the carrier by sampling the output of each transducer in rapid sequence, a technique called time-division multiplexing. The technique has been employed to handle as many as a million samples per second. It provides for simple data displays and easier separation of channels for recording or analysis, and is free of crosstalk. If possible, though, it is advantageous to use no multiplexing at all for concurrent data talking, but to use separate radio carriers for each measurement being transmitted. The multiplex telemeter requires careful adjustment of subcarrier frequencies, and precisely tuned filters to separate them at the receiver. This adds to the cost of the equipment and requires considerable experience of an operator.

The telemetry data received may be recorded in a number of ways, but such records must preserve the accuracy of the entire system. For example, if you are monitoring a one percent system and can distinguish 1/64 inch on a paper graph, the minimum graph size for full scale should be approximately two inches. Similarly, numeric data should be printed to enough decimal places to preserve the accuracy of the system.

A single channel of industrial FM/FM telemetry equipment may cost between \$1000 and \$2000, including everything needed for a given remote measurement—transducer, radio link, power supply, and simple indicator.

#### **Tired metal and wet snow**

High-voltage transmission lines are an excellent example of how inaccessible an object of measurement may be.

These lines vibrate in the wind, and the stresses and strains require measurement under the dynamic conditions that contribute to fatigue failure.

Strain tests to determine fatigue will show very quickly whether the endurance limit has been exceeded; and only if it is exceeded need we be concerned about fatigue failure. So it is necessary to measure the number and magnitude of the reversals in order to predict the time of failure. Telemetry techniques permit dynamic testing under actual service conditions rather than by simulated laboratory conditions or static tests.

Although the transducer that produces an electrical signal proportional to strain may have an output of 0.01 volt, the live transmission line to which it is attached may be at a potential of several hundred thousand volts. One problem is to detect this hundredth of a volt in the presence of a very large signal. In the language of the telemetry engineer, this is rejection of a common mode voltage of the order of  $10^8$  to 1.

Then why not de-energize the line? It's a simple matter of economics; an idle line transmits no energy. In addition, the wind forces that cause the line to vibrate are neither predictable nor constant. Weeks or months may be spent in gathering measurements for a particular set of spans. However, a radio telemetry link makes it possible to transmit the strain gage signal even while power is being carried. The technique employed involves attaching a self-contained FM radio transmitter to the transmission line at a point adjacent to the strain gage. It remains at the same electric potential as the line, much like a bird sitting safely on the wire, transmitting the transducer output to a radio receiver and recorder located at some convenient point on the ground where vibration analysis can be made. As a result, armor rod may be placed around the line at the vulnerable points, or vibration absorbers of the correct resonant frequency can be installed at the proper point on the line.

More down to earth, but equally inaccessible to measurement, is the strain on the chain belt of an earth mover. Too light a chain will fail from fatigue caused by the alternating stresses imposed by the full and empty buckets it transports.

Measurements made under actual operating conditions involve attaching strain gages to a chain traveling at 500 feet per minute, and subjecting them to violent shock and vibration. Since slip rings will not work on this kind of moving equipment, wire-link remote measurements are impossible. Instead, a transducer and a small, rugged transmitter are attached to points along the chain until the most vulnerable part of the chain is found. It is preferable to use several transducers and multiple channel telemetry equipment for such measurements to simplify correlation between load and the resulting strain at various links.

Telemetry also can determine water levels and flow rates of rivers to provide vital data for flood control or for efficient hydroelectric power generation. Data on the potential watershed into rivers can be obtained by analyzing the water content of snow that would eventually melt and feed off into them.

One requirement is to measure the depth and water content of snow in the mountains, then transmit these data from remote points to a central receiving station. The snow-measuring device may be a transducer consisting of a radioactive source atop a tall pole and a radiation in-

tensity meter on the ground. The gamma-ray intensity measured by the meter is a function of the height and water content of the intervening snow.

### Semiconductor transducers

Improvements in transducers are clearly opening up new measurement possibilities; for example, let us take the strain gage. Typically it has been a metallic element that was stretched. As its length increases, its cross section decreases (Poisson's ratio), thus increasing its electrical resistance. In a metal strain gage with a gage factor of two, resistance increases twice as fast as the length. However, new semiconductor materials exhibit a gage factor as high as 100 or 200. Consequently, the output of a bridge of semiconductor materials may be used to directly modulate telemetry subcarrier oscillators without further amplification. There are some drawbacks—semiconductor materials are temperature-sensitive and introduce greater drifts than metal foil. This problem is not insurmountable, however, for the arms of the gage may be located at a single point for temperature compensation.

Semiconductor piezoresistivity is also making possible simpler and more reliable pressure transducers than the conventional electromechanical pressure cells, which employ an elastic sensor with a deflection proportional to pressure. The ideal pressure transducer must provide a precise, repeatable measure of steady-state pressure. It must respond linearly to large pressure variations without permitting small pressure changes to be obscured by noise or threshold effects; moreover, there must be a minimum of interaction between the transducer and the medium whose pressure is measured. One recent development integrates the pressure sensor and the output devices in a single silicon strip. It has a dynamic response to 6 kHz.

Among the other promising approaches to pressure transducers is a chemical cell in which liquid displacement is used to unbalance a bridge. In this unit, a center electrode divides two sections of liquid which is metered through a small orifice. Electrodes at each end make up a unit which becomes half of the bridge. They are electrically connected by the liquid. The center electrode is displaced by pressure in a fluid, although it also could be moved by mechanical leverage or magnetic energy. A transducer of this type can measure absolute strain or strain rates, producing an output so high it requires no further amplification before being fed to telemetry transmitters. In fact, its amplification is limited only by temperature effects, which become increasingly important as the bridge configuration is physically changed to increase amplification.

Semiconductors are also appearing in light-actuated analogs of the mechanically operated potentiometer. Electromechanical potentiometers sense mechanical movement and translate it into voltages by changing the position of a sliding contact on a length of electrically resistive material. They have long been used for position-measuring and as pick-offs from accelerometers, gyros, torque angle meters, etc.

In the electrooptical solid-state potentiometers, the conventional wiper arm that makes the sliding contact has been replaced with a tiny light beam. The electrical element consists of a resistance film separated from an adjacent conducting strip by a photoconductive crystal. This photoconductive strip acts as an insulator when it is dark; but where the light beam hits it, an electrical connection is

made between the resistive and the conductive strips at that point. The output voltage is a linear function of the light-beam displacement on the resistor.

### An alarm from the tunnel

One new component that is making possible unprecedented flexibility in telemetry systems is the tunnel diode. Its two unique behavior characteristics as an electronic device—negative resistance and variable capacitance—are changing system design concepts. It needs so small a signal input that low output transducers can be used. Its negative resistance characteristic (the voltage drop across the diode decreases as the current increases) permits it to act as a single element trigger or to work in conjunction with a resonant circuit as an oscillator. A single tunnel diode may be adjusted to oscillate over a frequency range of less than 1000 Hz to greater than 1000 MHz. In telemetered alarms, a tunnel diode may operate first as a trigger actuated by a voltage which exceeds a certain value to provide the oscillation for the alarm signal.

Because it acts as a variable capacitor as the voltage varies, when a tunnel diode is used as an oscillator its frequency may be changed in accordance with the excitation voltage applied to it by the transducer. Thus a tunnel diode can be used as a proportional measuring system and part of a feedback control system.

Since a tunnel diode requires only a small voltage (about 0.08 volt) to start oscillation of a tuned circuit, and

Testing speed reducer by telemetric techniques.

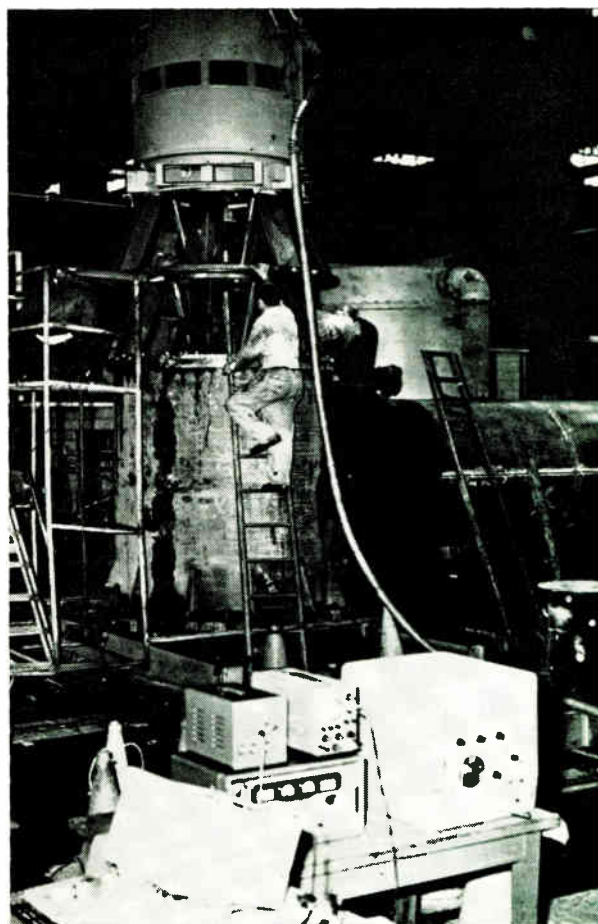

a low impedance (5 to 50 ohms), any transducer with these output characteristics may feed it a signal. With this relatively minute power requirement, such transducers as solar cells and thermocouples can be used. If necessary, smaller batteries can supply external power.

It is in the telemetry circuitry itself that the tunnel diode will have the greatest effect. A typical voltage-controlled subcarrier oscillator now consists of two transistors operated as a multivibrator with isolating transistors on the input and output. There are also many temperature-compensating diodes and thermistors to provide stable operation over a wide temperature range. All of this circuitry can be replaced with a single tunnel diode, an inductor, and a capacitor.

### Digital transducers

Practically all transducers are analog devices; that is, they produce an electric voltage proportional to the value of the physical quantity being measured. Yet one of the principal advantages of a digital signal for conveying data is that neither noise, nor system nonlinearities, nor intermodulation caused by signals produced by the sum or difference of the subcarrier frequencies can change the value of the quantity transmitted.

Therefore, the development of digital transducers is beginning to have a great impact on telemetry. These transducers are measuring instruments that convert a physical quantity into an electrical output consisting of a series of pulses that appear sequentially on a single circuit or concurrently on a number of circuits. When presented as a code, the pulses indicate the magnitude of the quantity.

The digital transducers presently available are not as simple as analog transducers and follow no carefully classified description. Many of them are built around the optical code wheel, which is widely used in determining angular positions, velocities, and accelerations, and converts an analog signal to digital form. The code wheel consists of alternate dark and light spots, which interrupt light hitting a sensor.

However, some transducers produce discrete outputs without using a code wheel, like one of the newer tank gaging devices. In another digital sensor for liquids, current is electromagnetically induced in the fluid and detected by a pick-off coil. Essentially, the sensor consists of two magnetic ceramic cores, each with a 2-turn winding. The energized winding of one will not induce a current in the other unless a conductive path is created through the center of both cores by liquid covering them both. A number of paired cores are mounted on a length of cable at points proportional to the volume per unit height of a tank. As the tank is filled, each pair of cores is covered with liquid and produces a finite voltage (say 2 volts) representing a digit. The voltage output of each succeeding pair is of such phase that it cancels the output of the previous pair.

Not every type of measurement can be made by a digital transducer. One of the greatest needs is still for a digital strain gage. And digital transducers require additional circuitry for modulating the transmitter with code pulses.

### Radio capsules and power sources

The subcarrier oscillators and transmitters in most industrial radio telemeters use miniature solid-state components assembled in an extremely compact fashion and protected, by encapsulation, from the destructive effects

of shock, acceleration, vibration, humidity, and corrosive vapors.

Batteries are typical active power sources, whereas a passive source may be as simple as a wire coil, which picks up energy induced in it by the field of a rotating motor or by radiation of power from a radio transmitter. Batteries such as nickel-cadmium cells can be used for a full working day of telemetry tests and then be recharged overnight, but disposable cells of mercury, carbon, or alkaline are lighter and smaller, with longer continuous operating life. A mercury cell can provide 200 hours.

However, some operating temperatures encountered in industrial telemetry impose serious limitations on batteries. Although few telemetry installations now operate above 100°C, new batteries are being developed for use at higher temperatures.

### Passive telemeters

Passively powered telemeters offer some interesting advantages. When a number of telemeters are used, they can be powered in sequence or only when measurements are required, thus preventing RF congestion. In medical applications of telemetry, passive devices eliminate the danger involved in swallowing or implanting batteries.

When a telemeter is mounted in rotating equipment, a small coil can generate power as it moves past nearby permanent magnets; a rectifier and a regulator are all that is needed to keep the telemetry equipment operating as long as the machinery is in motion.

Most passive telemeters are essentially an inductance and a capacitance coupled as a resonant circuit. Either of these components may be pressure-sensitive or temperature-sensitive. A nearby magnetic coil coupled to this circuit can, by means of a varying frequency, determine the resonant point of the telemeter, which can then be a function of the temperature or pressure being measured.

### The receiving station

The industrial telemetry receiving station differs vastly in purpose and principle from the transmitting station. Its usual environment is no more difficult to cope with, in terms of ambient temperature, shock, and vibrations, than that of an automobile radio. It receives signals over short distances in which subcarrier frequencies are so widely spaced that harmonics and drift are no problem.

In the FM broadcast band, available professional-grade high-fidelity tuners have sensitivities of 1 or 2 microvolts for 30 dB of quieting of extraneous noises, as well as automatic frequency control circuits to compensate for both transmitter and receiver drift. They feed telemetry phase-lock discriminators, which lock the receiver into the frequency and phase of the incoming signal. The radio receiver portion of an industrial ground station can cost roughly \$100, rather than about \$2500 for a highly accurate crystal-controlled missile telemetry receiver.

The transmitters usually radiate from the resonant elements themselves, avoiding elaborate antennas that might be required for longer distance transmission; the receivers use simple dipole or commercial television antennas. Thus, it can be seen that industrial radio telemetry has become a carefully engineered blend of the borrowed and the new.

Essentially full text of a paper presented at the 1966 National Telemetry Conference, Boston, Mass., May 10-12, 1966, and published in the Conference Proceedings, pp. 86-90.

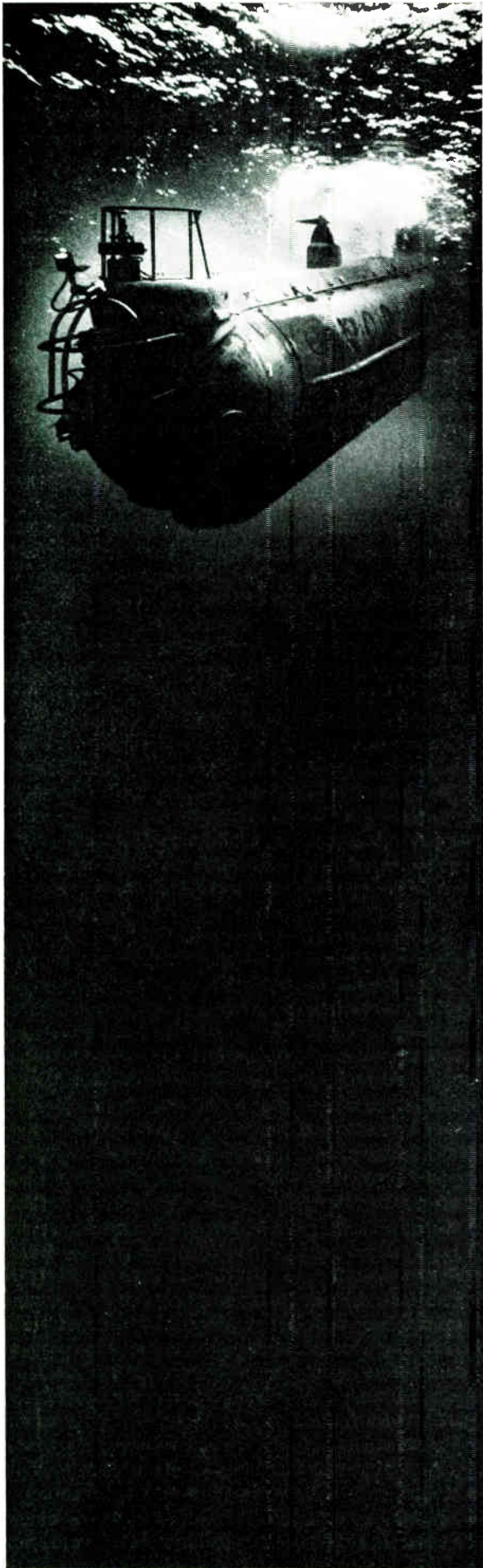

# Ocean engineering:

*Deep-diving submersibles, the man-in-sea program, and Project Mohole are but a part of the huge stake to which the United States is committed in the scientific push toward the total development and exploitation of undersea resources*

*Gordon D. Friedlander*    *Staff Writer*

Millions of years ago, man in his evolution may have emerged from the sea to adapt himself to a land environment. With projected population curves spiraling upward, man may have to return to his primordial habitat to achieve the elbowroom necessary for survival on this planet. Captain Jacques-Yves Cousteau, the noted French undersea explorer and scientist, is convinced that colonization of the sea floor by the human species will be realized before the turn of the 21st century. Therefore, man must condition himself, through the experience of prolonged submergence, to readapt to the strange, hostile, and silent world of the briny deeps.

What is it like? The eyewitness report of a world-famous news commentator vividly describes the weird, awesome, and mysterious sights he viewed at a depth of 650 fathoms when he traveled as an observer on a recent dive aboard the Deepstar-4000.

But pragmatically, in terms of contemporary applications, the manned, deep-diving submersible is indispensable in the execution of a comprehensive ocean-bottom survey in which the positive identification and detailed analysis of unusual or significant topographical features must be made.

*"The earth is young and gay on a fine spring day  
When the air is sunny and warm  
But the earth is old and hoary and cold  
When you look on the sea in a storm."*

*Sir John Chandos*

## **An historical preface**

Ever since Captain Nemo piloted the *Nautilus* "20 000 Leagues Under the Sea," in Jules Verne's immortal, 19th century science-fiction classic, man's desire to

(Left) "Aluminaut," world's deepest-diving true submarine, glides like a huge metallic fish through the murky depths of the Atlantic Ocean.

# probing the depths of a wild frontier

explore the mysterious canyons of our seabound planet has been intensified.

In 1934, the scientific community was justifiably thrilled when Dr. William Beebe, an eminent marine biologist and explorer, descended to the incredible depth of 3028 feet off the Bermuda archipelago in a specially constructed spherical steel diving chamber, appropriately named the *bathysphere*.

The Beebe cable-supported vehicle, however, had severe exploratory limitations due to its lack of mobility and inadequacy of scientific instrumentation. Also, the gasketing, caulking, and sealing techniques to ensure watertight integrity at pressures of more than 2000 psi posed a major technological problem at that point in time.

During World War II, a significant advance in undersea technology—at least in its military applications—was the advent of the “frogman,” a free diver whose gear included a self-contained underwater breathing apparatus (SCUBA), a rubber protective suit, flippers, face mask, and whatever explosives or cutting torches were required for demolition and salvage work.

**The bathyscaphes.** In 1947, the Swiss scientist, Auguste Piccard, invented the *bathyscaphe*, a revolutionary new concept for the design of a deep-diving submersible. The first successful—although unmanned—dive of this vehicle was made in 1948 to a depth of almost 5000 feet in waters off the Cape Verde Islands. The craft was then rebuilt by the French navy and, by 1958, some 60 descents, in which a maximum depth of about 13 500 feet was attained, were made off Dakar.

A second vehicle, the *Trieste* (Fig. 1), was built by Piccard in 1953, and in 1958 this craft was transferred to the U.S. Navy and based at San Diego. In January 1960 *Trieste*, with Jacques Piccard (the inventor's son) and Lt. Don Walsh, U.S.N., aboard, reached a 35 800-foot depth in the Marianas Trench off Guam. The descent required  $4\frac{3}{4}$  hours and the ascent  $3\frac{1}{4}$  hours. During the half hour at the bottom of the trench, the hull of the submersible was subjected to a pressure of 16 883 psi!

The bathyscaphe is an untethered, self-propelled submersible whose basic concept is analogous to that of a lighter-than-air craft, or blimp. A gasoline-filled flotation hull is designed to deform under the enormous hydrostatic pressure of the deep-sea environment. Seawater is freely admitted at the bottom of the hull where it displaces the immiscible gasoline. Since the latter fluid has a density of about 0.70, it floats on top of the water ballast and provides the necessary buoyancy to the craft. Additional ballasting is achieved by iron pellets, which may be jettisoned as the craft ascends. Since this ballast is held by magnetic valves, it will be automatically released in the case of an electrical failure, thereby providing a

fail-safe mechanism to ensure that the craft will surface.

The spherical, forged-steel pressure-resistant gondola, or observation cabin, is large enough to contain two people. Heavy Plexiglas portholes are provided for observation. The accessory equipment includes floodlights, navigational instruments, and electronic scientific gear. A recent modification includes a hydraulically operated manipulator arm for taking ocean-bottom samples.

In a diving operation, the entrance air lock (Fig. 1) is flooded during the descent and blown out by compressed air during the ascent. The cabin contains 12 pressure sleeve lead-throughs for the multiconductor electric cables that are necessary for the operation of the craft. Storage batteries provide the propulsion power for two propellers that afford the vehicle a sluggish horizontal maneuverability (2 knots headway) for short distances.

In the case of the bathyscaphes, submergence is initially effected by flooding the fore and aft ballast tanks. Additional negative buoyancy can be attained, if required, by valving off some of the gasoline.

In 1962, a larger and more maneuverable bathyscaphe, *Trieste II*, was launched by the U.S. Navy. This craft was most instrumental in the search for the ill-fated nuclear-powered submarine *Thresher* in 1963.

**The present picture.** During the past five years, numerous deep-diving submersibles, designed for a variety of oceanographic purposes, have been in use. These vehicles fall into four basic categories: tethered unmanned, tethered manned, untethered unmanned, and untethered manned.

Fig. 1. Inboard profile of bathyscaphe “Trieste,” showing the principal mechanical and propulsion components.

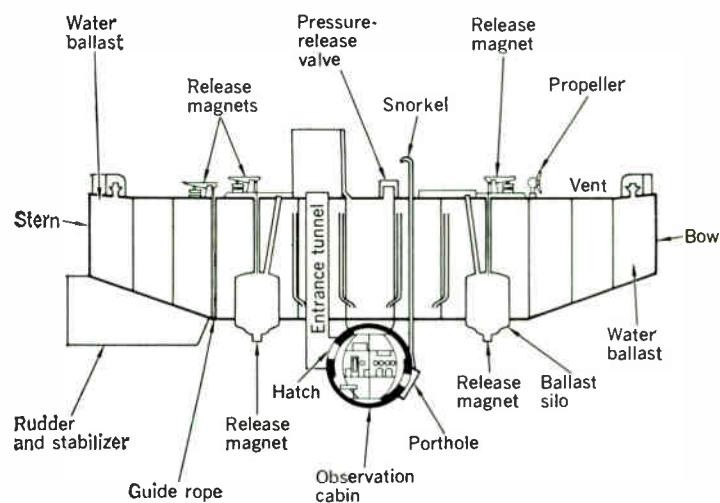

**Criteria for vehicle selection**

Unmanned tethered vehicles<sup>1</sup> have been successful only when they were designed for a specific task to be accomplished under a set of predetermined parameters. A good example of such a craft would be the towed, sonar-equipped submersibles that are used in the search for sunken ships or in plotting ocean-bottom topography.

Manned tethered vehicles, such as the bathysphere, have been useful for observation on a spot location of maximum interest, and they have been successful to a limited degree in gathering samples and in object handling.

Thus far, unmanned untethered vehicles have been used only for specific data acquisition in areas (such as radioactive waters) that might be hazardous for the personnel of manned submersibles.

For the free submersible in the final category to do useful work on or near the sea bottom, it must meet a set of design specifications that take into consideration:

*Safety of personnel.* This is the top-priority design factor and it involves a maximum effort in R & D, planning, and construction ingenuity.

*Reliability.* The submersible must be capable of carrying out its task assignment with a high degree of probability for success and with a minimum required downtime for system maintenance and repair.

*Endurance.* The undersea vehicle must have an adequate life-support system and should be able to undertake prolonged operations without crew changes, battery recharges, or other refueling.

*Ruggedness.* The craft should be of sufficient strength and seaworthiness to withstand launching and recovery operations, without damage to its structure or danger to personnel, in adverse weather and sea-state conditions.

*Maneuverability.* The vehicle must have sufficient propulsion power, steering way capability, and stability to accomplish its mission in one diving operation.

**Contemporary roster of manned vehicles**

Table I lists the wide range of manned submersibles that are being employed for oceanographic research programs and commercial applications. For comparative purposes, this table is divided into three subsections: A—vehicles whose capabilities are limited to maximum depth of 1000 feet; B—submersibles having mid-range depth limitations (4000–6000 feet); C—deep-diving craft, capable of reaching the greatest known ocean depths.

Vehicles in the “B” classification are generally those with the most extensive exploration and research equipment, maneuvering capabilities, and devices for gathering mineral and biological samples. The submersibles in the “C” category are designed primarily for their ability to reach extreme depths and their maneuverability, and research and exploratory equipment are usually minimal.

**The ‘Diving Saucer’**

The forerunner of Westinghouse’s “Deepstar” program was the highly successful *Diving Saucer*, designed by Captain Jacques-Yves Cousteau, which has been in operation since 1959, manned by Westinghouse personnel in cooperation with the research efforts of the Scripps Institution of Oceanography. Capable of diving to the 1000-foot level (167 fathoms), the *Saucer* was designed to extend human ability in the exploration of the oceanic continental shelf areas.

The craft is readily transportable, either by surface vessel or air-cargo plane, thereby making it a highly mobile system that may be used for oceanographic surveys in remote geographical locations.

The vehicle was designed so that its pressure-resistant steel hull provides the positive buoyancy required with a minimum of ballast tank assistance. Employing a unique water-jet propulsion system, the vehicle can cruise submerged at about a one-knot speed. It is maneuvered by controlling the water-jet nozzles and actuating an externally mounted, hydraulic mercury pitch unit. Diving and surfacing are achieved by jettisoning solid ballast.

Following its launching from the surface support ship, the *Saucer*, trimmed to negative buoyancy, makes its free descent, during which time the sea floor is monitored by a bottom-scanning sonar. The release of a solid-ballast unit creates a neutral hovering buoyancy at a relatively constant depth. The motor that drives the jet pump is then started and the craft may cruise at varying depths. Navigation is achieved either visually or by means of instrumentation.

At the conclusion of a normal, 4-hour dive, the pilot releases the second weight and the craft ascends. The *Saucer* carries a 2-man crew—a pilot and an observer—plus about 100 pounds of scientific gear as payload.

Since 1959, the vehicle has made hundreds of dives off the coast of Baja California, almost 200 of which were undertaken over a 7-month period in 1964–1965. The

**I. Classification and characteristics of some contemporary submersibles**

Class	Name	Maximum Depth, feet	Length, feet	Weight, tons	Crew	Normal Endurance, hours
A. Small vehicles—depth capabilities to 1000 feet (continental shelves)	Perry Cubmarine 3B	600	20	2.7	2	8
	Star I	200	10	1.2	1	4
	Star II (Asherah)	600	16	3.5	2	8
	Diving Saucer (Soucoupe)	1 000	9.5(diam.)	3.5	2	4
B. Small vehicles—depth capabilities to 6000 feet	Alvin	6 000	22	15	2	10
	Deepstar-4000	4 000	18	9	3	12
C. Large vehicles—deep-diving capabilities	Aluminaut	15 000	51	75	3	32
	Trieste II	20 000	67	220	3	10
	Archimede	36 000	70	210	3	12



following account, extracted from the log of a recent dive, portrays a dramatic word picture of another world:

"Dive 340—The *Saucer* moved down a gentle slope . . . At 190 meters, there was an abrupt slope change as the *Saucer* went over a cliff with very steep walls. . . the claw was used to take a sample.

"As the *Saucer* descended and approached 230 meters, the canyon walls appeared to be rock and no sediment was visible. . .

"Among the fauna observed was a strange-looking eel. It had no eyes, and the mouth was open, looking like a jet. . ."

### The 'Deepstar' series

Although much valuable training and experience was acquired by pilots and observers from their French instructors in the operation of the *Diving Saucer*, the vehicle was essentially a French product in design and concept. Thus, about three years ago, Westinghouse embarked upon its Deepstar program for the design and construction of a series of self-propelled submersibles, capable of attaining successively greater depths and appropriately named *Deepstar-4000*, *12 000*, and *20 000* (the numerical suffix indicating the craft's maximum operating depth in feet).

'Deepstar-4000.' The first edition, *Deepstar-4000* (see Fig. 2), completed in mid-1965, is a 10-ton craft that has a spherical, pressure-resistant hull made of high-strength steel alloy (HY-80). Covering the sphere is a teardrop-shaped, Fiberglass hydrodynamic fairing, sup-

ported by a framework of aluminum tubing. The vehicle measures 18 feet in length by 11½ feet in width by 7 feet in height.

Mounted within the fairing, but outside the pressure sphere, are the batteries, pumps, syntactic foam buoyancy material, ballast tanks, propulsion motors, and hydraulic buoyancy and trim systems. This part of the vehicle is flooded during submersion; however, the components are designed for immersion in seawater and are built to withstand a pressure of more than 1800 psi.

Electric power for *Deepstar-4000* is supplied by three lead-acid batteries, with a total capacity of 400 ampere-hours at 115 volts output. Navigation and recording equipment installed within the pressure hull includes a gyrocompass, two-way radio, tape recorder, echo sounder, movie camera, and an underwater telephone. The external gear includes a high-intensity movie lamp, a strobe flash, a 70-millimeter still camera, a mechanical arm with sample-collecting pincers, and floodlights.

Two 4.4-inch-diameter ports, located low in the bow of the vehicle, permit an overlapping horizontal view of about 150 degrees of arc to the pilot and observer, who lie prone (Fig. 2) on two couches when the vehicle reaches its operational depth. A seat near the center of the sphere is provided for the copilot-observer.

A mercury ballast system controls the trim of the vehicle. Two fast-acting hydraulic pistons in the forward and aft tanks pump the mercury back and forth to shift the vehicle's center of gravity. The craft is propelled by two 14-inch-diameter propellers, each driven by a 4.5-hp ac induction motor. Steering is controlled by increasing or decreasing the speed of one propeller. One large weight attached to the bottom of the fairing causes the vehicle to descend. When the desired depth is reached, the

Fig. 2. Cutaway section of a typical "Deepstar" vehicle, showing the various electrical, mechanical, and hydraulic equipment used for the operation and conning of the submersible.

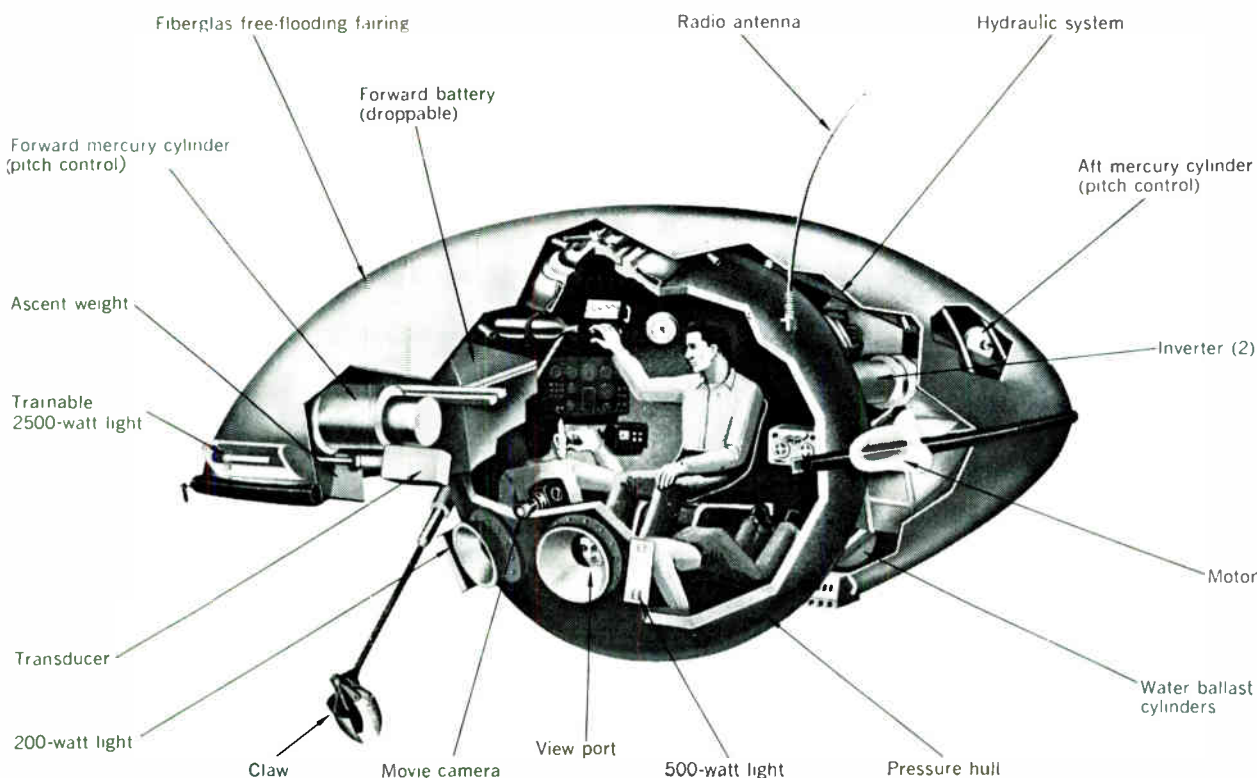

weight is jettisoned and the submersible becomes neutrally buoyant. To ascend, a second weight is cast off from the forward part of the fairing.

The life-support system provides a 48-hour oxygen supply for a three-man crew. Carbon dioxide is absorbed by lithium hydroxide granules. Safety features include a manual ballast drop, forward battery release for an emergency ascent, and a fail-safe mechanism to limit the time and depth of a dive.

#### A correspondent takes the plunge

The writer recently interviewed the distinguished CBS Television commentator, Walter Cronkite, who, on June 18, 1966, participated as the "third man" observer in a dive of the *Deepstar-4000* (Fig. 3) to the continental slope off La Jolla, Calif. Cronkite, a director of the newly formed National Oceanography Association, reported that he felt neither physical discomfort nor disorientation during the course of the helical free descent and ascent paths of the vehicle (see mission profile illustration, Fig. 4). In the long plunge to almost the maximum depth limit of the submersible, he noted "plankton that resembled stars and snowflakes." The task assignment of his diving mission was "to work up the continental slope to find rock outcroppings."

He experienced no sensation of claustrophobia during the 5½ hours of close confinement within the 6½-foot-diameter pressure sphere: "It was about the same as being in a sleeping-car roomette!"

Cronkite noted that third-dimensional perception is almost totally lost when observing floodlit objects, at great depths, through the viewing ports. Due to the water magnification and distortion, "it was impossible to tell whether a fish was ten feet or a hundred feet distant." Mr. Cronkite felt that he should dispel one popular notion about the ocean floor: "For the most part, it's

not the exotic 'silent world' of Cousteau's recent movies; much of it is pretty drab, lifeless, and vaguely frightening. You know that it is an alien and hostile environment. The coral wonderlands, with their rainbow spectrum of flora and fauna, are the exception, not the rule."

On the subject of R & D in oceanography and its engineering applications, Cronkite observed that "private industry is leading the government." Firms such as Westinghouse, General Dynamics, General Electric, Litton, and others have financed the major portion of the design and development and construction costs of the deep-diving vehicles, and petroleum and mineral exploration equipment. (In one recent instance, as will be noted later, industry's deep-sea equipment has performed specialized services for the military establishment.)

To the writer's question as to whether he felt that his trip in *Deepstar* was analogous to "being shot into orbit" without prior training or preparation, Mr. Cronkite replied: "No, the parameters are not the same. Since the crew of the diving craft are not subject to accelerative forces and perform their tasks at normal atmospheric pressure within the cabin, no special pressure suits or helmets are required."

The final question of the interview was: "Would you go down again in *Deepstar*?"

Cronkite: "Of course!"

#### The 'Stars' and 'Aluminaut'

General Dynamic's Electric Boat division is presently operating two deep-diving craft—in addition to vehicles that operate in the 200–600-foot depth range—*Star II* and *Star III*. Electric Boat also built *Aluminaut*, the world's first aluminum submarine, for Reynolds International, Inc.

*Star II* is an advanced submersible for scientific research and ocean engineering, primarily on the continental shelf. Its maximum operational depth is 1200 feet. Reversible, 2-hp electric motors give the craft a 4- to 5-knot submerged speed. Its diving duration is eight hours, and a 24-hour life-support system is provided for a two-man crew. A 250-pound payload includes television cameras, sonar, and research instrumentation.

*Star III*, a 10-ton craft capable of attaining a maximum depth of 2000 feet, is propelled by a 7.5-hp stern-mounted electric motor. The boat is equipped with the latest navigational and electronic tracking gear, plus a sampling claw with interchangeable "hands" for collecting various biological and mineral specimens from the sea floor. The craft can remain submerged up to 12 hours and has a 24-hour life-support system for a pilot and an observer.

*Aluminaut* (see illustration on page 94 and Fig. 5), a true submarine with a cylindrical pressure hull in which all propulsion machinery and equipment is contained (rather than the spherical pressure-resistant cabins and external accessories of the submersibles), is designed to explore to a depth of 15 000 feet, which implies a capability of reaching 75 percent of the ocean floor areas of the world. The 75-ton, 51-foot-long boat has a 30.5-hour operating endurance with a three-man crew, but it can accommodate additional observers on dives of shorter duration.

Horizontal propulsion is achieved by two 5-hp dc motors, internally housed, that turn twin screws mounted on the port and starboard stabilizing fins. An unusual feature is the boat's vertical propulsion system (Fig. 5),

Fig. 3. A famed newsman takes a plunge. CBS Television correspondent Walter Cronkite is shown participating as the "third man" in the "Deepstar-4000" dive of June 18, 1966.



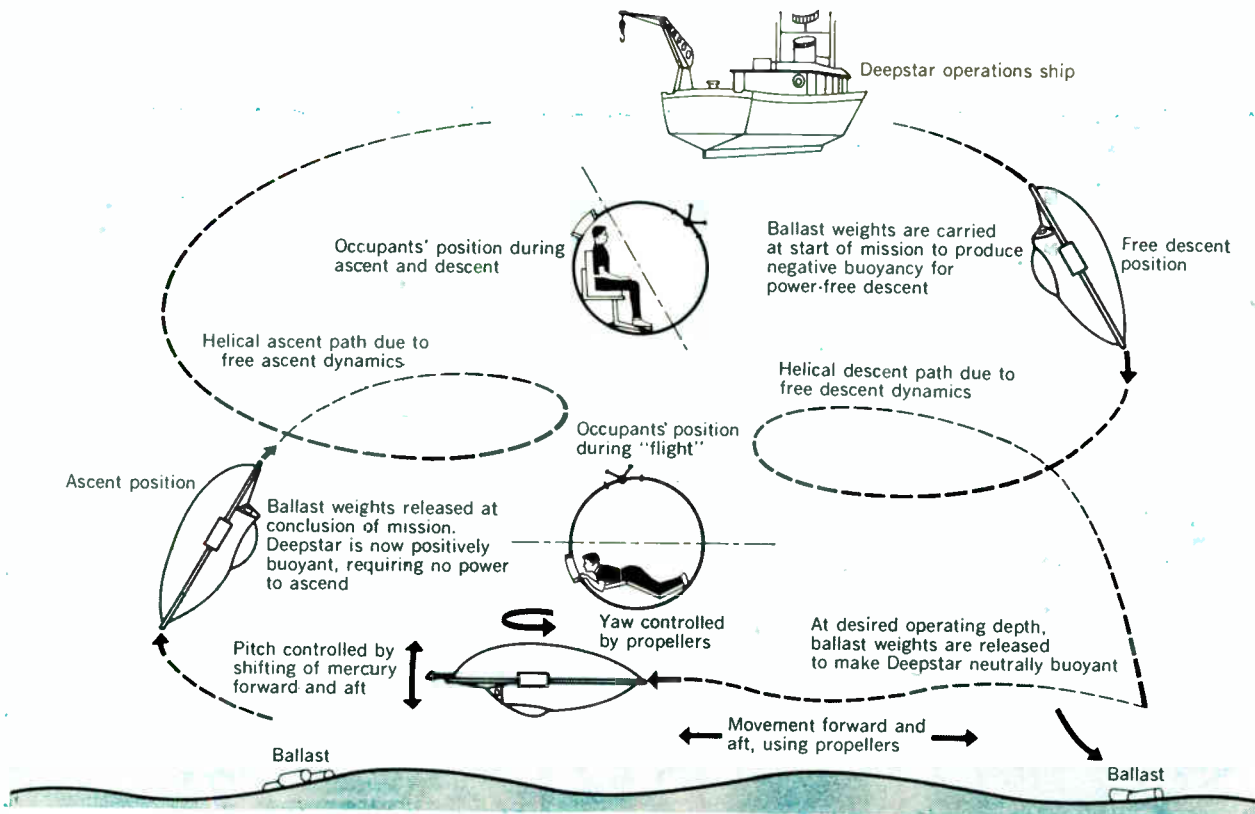
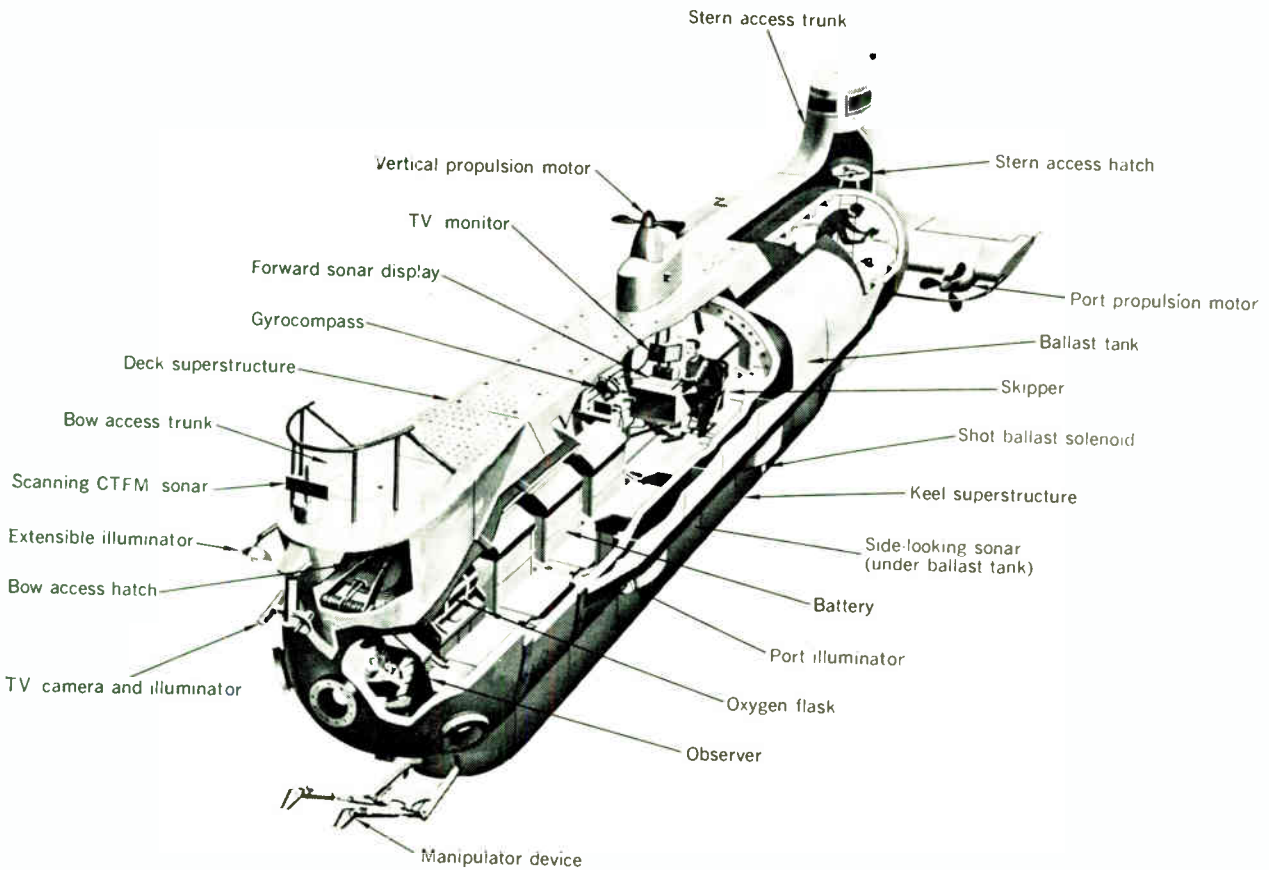

Fig. 4. "Deepstar" mission profile. Diagram indicates the helical descent and ascent paths described by the vehicle during its free fall and rise.

Fig. 5. Cutaway three-quarter view of "Aluminaut," showing hull structure, propulsion machinery, and electric and electronic gear.



which consists of a top-mounted propeller that is driven by a single 5-hp dc motor in the midship housing. Power is supplied by four 77-cell silver-zinc storage batteries. Each battery delivers 32.5 kWh.

*Aluminant* is equipped with a gyrocompass, Fathometer®, sonar, underwater and radio telephones, television, and mechanical-arm manipulators for retrieving ocean-bottom samples. The sonar system, with three transducers (for up, down, and forward scanning), has a 600-foot range. The boat has a cruising radius of about 80 miles at a 3.8-knot speed.

#### 'Alvin' and its brood

The original *Alvin*, built by Litton Industries for the Woods Hole Oceanographic Institution (Fig. 6), has a maximum depth capability of 6000 feet.<sup>2</sup> A life-support system of 24 hours for a two-man crew, a 10-hour standard dive duration, a maximum submerged speed of 4 knots, and a 1200-pound payload of scientific and electronic instrumentation, afford this submarine an unusual range of practical sea-bottom work and research capability. In addition, 18 kW of electric power is available for scientific purposes other than life support and propulsion requirements.

*Autec I* and *Alvin II* are two-man research submarines, capable of work at the 6500-foot level, to be built by Electric Boat for the U.S. Navy Ship Systems Command. *Autec* will be operated by the Atlantic Undersea Test and Evaluation Center, situated in the "Tongue of the Ocean" off the Bahamas. *Alvin II* will serve the Office of Naval Research.

During the summer of 1965, *Alvin* completed several dives to her designed depth of 6000 feet in the Tongue of the Ocean (a deep canyon in the Bahama group). Prior to these plunges, in an unmanned dive, the craft reached a depth of 7500 feet without structural damage.

From February to April 1966, *Alvin* made 34 dives off the coast of Palomares, Spain, in waters of 2800-foot depth, in the search for an H-bomb that was lost following the mid-air collision of two United States Air Force planes. The submersible located the bomb on two occasions and, therefore, rendered considerable assistance in the eventual recovery of the missile.

#### 'Man-in-sea' program—the 'Sealab' experiments

When the writer visited the Scripps Institution of Oceanography at La Jolla last May, he asked one of the faculty scientists whether any electronics experts were assigned to the *Sealab II* experiment. "Hell," was the half-serious reply, "you don't have to be an electronics expert to go down in *Sealab*—you just have to be crazy!"

Well, crazy or not, this phase of the U.S. Navy's man-in-sea program for the environmental adaptation—and survival—of divers exposed to long-term submergence, under hydrostatic pressures of more than 100 psi, has already progressed through two *Sealab* ventures, and preparations for *Sealab III* are presently under way.

As Commander Scott Carpenter, U.S.N., put it, following his *Sealab II* experience<sup>3</sup>: "First, forget all you've seen of Lloyd Bridges' underwater world. *Sealab* waters are . . . dark, dirty, and cold. We realize that most of the waters of the world are not warm, clear, and inviting. And we know that these are the surroundings to which man must adapt himself and his equipment if he is to prove he can live and work in the sea . . ."

#### 'Sealab I'

The habitat for the first *Sealab* experiment in 1962 was constructed by welding together two parts of a metal hull to form a cylindrical unit 50 feet long by 10 feet in diameter. A hole was cut in its bottom to permit the ready access and egress of personnel equipped with skin-diving gear. Several old railroad ties and lead billets served as ballast. Gas bottles of a highly compressed helium-oxygen mixture supplied the breathing atmosphere and an umbilical cord to the surface completed the bulk of the essential components. Bunks for five aquanauts rounded out the domestic aspect of the strange "home" for the projected 21-day experiment.

On the fourth attempt, *Sealab* was lowered successfully to a level bottom 193 feet down in a preselected spot in the Atlantic southwest of Bermuda. Unfortunately, however, an unpredicted hurricane swept down on the area during the ninth day of submergence. An emergency attempt was made to raise the aquanauts and the habitat en masse, but 18-foot-high ocean swells made the effort too hazardous. Therefore the aquanauts were transferred to an underwater decompression chamber and brought to the surface to complete the necessary decompression.

Although the experiment was abruptly terminated long before its scheduled duration, it proved conclusively that people could survive for an extended time on the ocean floor, engage in work activities as free divers for periods up to six hours, return to their habitat to exist fairly normally under abnormal conditions, and, finally, return to the surface without subsequent adverse physiological effects.

By present standards, the cost of the *Sealab I* venture was a bargain—only \$148 000.

#### 'Sealab II'

The tragic loss of the nuclear-powered submarine *U.S.S. Thresher* in April 1963 apparently accelerated the implementation of the U.S. Navy's "man-in-sea" concept of a five-year program for putting large numbers of people on the ocean bottom to do useful work at depths of 600–800 feet for periods of more than 30 days. *Sealab II* represented the first step in this ambitious undertaking. Working in cooperation with the Scripps Institution of Oceanography, a location about 3000 feet off the Scripps pier at La Jolla was selected for the next experiment, the manned phase of which began on August 28, 1965.

During the 45-day-long *Sealab II* program, three teams of aquanauts—including Commander Carpenter—lived in and operated from an underwater base (Fig. 7) at a depth of 205 feet for 15-day periods. The aquanauts conducted numerous scientific tests and experiments inside the habitat and as free divers equipped with special SCUBA gear.

**The instrumentation packages.** Very elaborate instrumentation packages for use both inside and outside the habitat were provided for this second man-in-sea experiment. Prior to the positioning of *Sealab II* on the bottom, a self-contained current meter was placed at a depth of 650 feet in the Scripps Submarine Canyon (Fig. 8). Because the mooring lines from the surface support vessel were fouled, this station, unfortunately, could not be used during the *Sealab II* operation. A taut wire mooring, at a depth of 215 feet, was substituted and the data collected were compared with the data from a

nearby underwater weather station that was positioned at a similar depth.

Data from all functioning sensors<sup>4</sup> were transmitted to a control center ("benthic control"), situated at the landward end of the 1000-foot-long Scripps pier, where it was recorded in both digital and analog form. Data from the pier-end instrumentation were transmitted by a direct cable while information from the underwater weather station was transmitted through a telemetry system that had its seaward terminal in a benthic chamber. Six 2-conductor and three 4-conductor cables connected the instrument array on the weather station platform to an equipment rack within *Sealab*. To ensure that the variable-resistance sensors would receive a constant excitation current, a single 300-volt power supply was installed in this equipment rack and individual 300-kilohm resistors, connected to the power supply, provided an excitation current of one milliamper for each sensor. Since the resistors were mounted within *Sealab*, very low amperage was available in the water. Thus a 12-volt power supply, also fitted to the equipment rack, afforded regulated, constant-voltage power at about 0.75 ampere for electronics packages within the current meters and the Vibrotron<sup>®</sup> pressure sensor, and for signal power amplifiers in the equipment rack.

The analog-to-digital converter aboard *Sealab* changed the signals from variable-resistance sensors to digital form for transmission via the telemetry system. Signals from the current meters and the Vibrotron, however, were already in digital form. Digital channels of 12 bits each were sampled every 6 to 12 seconds by the converter, but the more important data channels were connected directly to the telemetry system and could be sampled as often as desired.

A multiconductor cable connected all signal channels from *Sealab* to the benthic telemetry chamber, from which point data were transmitted to the shore station by means of an AM multichannel carrier telemetry system on a single coaxial cable.

**Instruments and their modifications.** Since the *Sealab II* experiment required testing equipment and apparatus for highly specialized research for long periods of time at unusual water depths, very few off-the-shelf hardware items could be directly employed without prior modification to adapt to the environment. And a number of instruments had to be specially fabricated in the Scripps machine and electrical shops.

For example, the accurate measurement and recording of low-period low-velocity undersea currents required a modification of the reliable and time-tested Savonius rotor. A modified rotor was incorporated into two types of Savonius current meters that were used in the *Sealab II* research. A watertight "Cyclocac" plastic sheet, neutrally buoyant in seawater, was employed to enclose the magnetic north and fixed-reference current direction sensors and the light source housings. To prevent excessive frictional wear in prolonged usage, the rotors were mounted on sapphire and tungsten carbide bearings.

Sixty equally spaced holes near the periphery of one rotor end plate interrupted a light beam as the rotor was turned by the water current. One pulse was generated as the beam passed through each hole and another pulse was generated as the beam was interrupted, thereby producing 120 electrical pulses for each revolution of the rotor. This pulsing digital output signal proved to be

very reliable in transmitting data over long telemetry channels because the signal is little affected by amplitude modulation that is produced by the normal noise pickup during transmission.

Several light sources for the meter were tested. A small bulb, capable of resisting the high pressure of the environment—and marine growths—was finally selected.

The Vibrotron pressure sensor was selected for use at the sea-bottom weather station because of its ability to detect small variations in absolute pressure while in a high-pressure environment. This instrument was modified so that the excitation and signal amplification electronic circuitry could be contained in a modular packaging for housing in an oil-filled canister with the transducer.

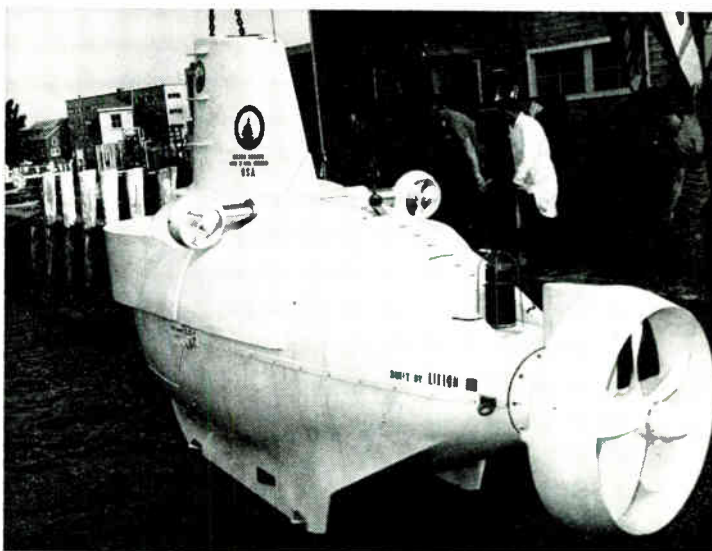
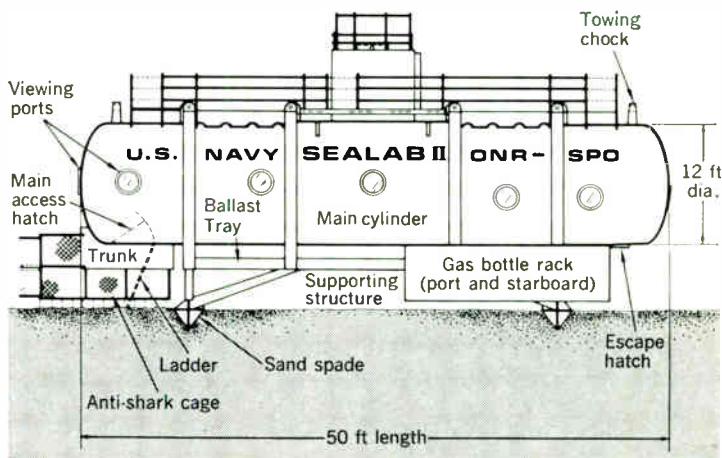

Fig. 6. Stern-quarter view of Woods Hole Oceanographic Institution's "Alvin." This submersible is capable of attaining a depth of 6000 feet. It was instrumental in the location and recovery of a lost H-bomb last winter in waters off the coast of Spain.

Fig. 7. Outboard profile of the "Sealab II" habitat. Three crews, consisting of ten aqanauts each, used this sea-bottom "home" as a base for their frequent skin-diving operations during the course of the 45-day-long experiment.



The audio output signal was telemetered directly to the data-acquisition system on shore, where the frequency variations were digitized and recorded on magnetic tape.

**The data-acquisition system.** A system of analog and digital recorders, complete with amplifiers, digitizers, and logic-control units, was located in the shore-based control center. A 12-channel chart recorder monitored analog readouts from the underwater weather station and the pier-end anemometer. A separate chart recorder monitored an analog conversion of the pier-end digital wave staff. Figure 9 shows typical analog records of these data for two days of the *Sealab II* experiment.

Plug-in printed-circuit logic boards were used in the acquisition system to digitize the sampled data, to store information from all input channels into memory banks, and to present the information to a high-speed tape recorder for permanent storage. The tape record was in standard IBM format and could be programmed directly into a computer for analysis.

### **The habitat—and some environmental problems**

Although the scientific test data acquisition phases of the *Sealab II* experiment were important, the primary purpose of the project was to determine the physiological effects on the aquanauts of long periods of confinement in an unnatural environment in which high atmospheric pressure, low temperatures, quasi-weightlessness, and poor visibility were the principal physical discomforts.

Picture, if you will, an odd collection of surface support vessels, a barge, and, finally, a 50-foot-long by 12-foot-diameter (Fig. 7) steel cylinder—the underwater home for ten men over a 15-day period. The strange habitat is equipped with neither an airlock nor a hatch. Since the atmospheric pressure inside equals that of the seawater outside, entrance and exit are achieved by merely swimming through an opening in the underside.

It has been known medically for some time that human beings cannot survive very long by breathing highly compressed air. In a matter of minutes, nitrogen narcosis produces a surgical anesthesia effect that can be fatal in longer exposures. And, although the nitrogen in our normal air supply is dangerous under such usage, the oxygen content must also be carefully controlled.

In experimentation on animal subjects—and eventually on human volunteers—it was determined that, by substituting helium for nitrogen and reducing the oxygen content in the mixture, and adding small percentages of the inert gases (argon, krypton, neon, and xenon), a satisfactory breathing atmosphere for human use at pressures of more than 100 psi was possible.

By means of a newly developed “saturation technique,” the divers’ body fluids and tissues were intentionally saturated with the special breathing mixture. When the saturated condition has been attained, a person can work from four to eight hours a day for periods in excess of one month without increasing the required decompression time before returning to the surface.

And there were puzzling questions whose answers could only be found empirically:

*What would be the effects of high atmospheric and seawater pressures on electronic equipment, and electric and pneumatic power tools?*

*What modifications would be needed in underwater lighting equipment, provision packaging, and thermally insulated clothing?*

### **Some surprises and frustrations**

Captain George F. Bond, U.S.N., of the Special Projects Office of the Bureau of Naval Weapons (the senior medical officer participating in the *Sealab II* project), recently gave a graphic account of some of the medical and environmental problems in an address delivered at the Franklin Institute in Philadelphia.

According to Captain Bond, the first erroneous assumption was that *Sealab* could be placed on a dead level spot on the sea bottom: “There is no such thing. . . We put her down the best we could. She had a 6-degree up angle and a 6-degree port list. The men called it the ‘tiltin’ Hilton’ . . .”

One of the earliest frustrations encountered—for which there was no remedy—was the difficulty in vocal communications. In the high-pressure helium-oxygen environment, the human voice became so badly distorted into a high-pitched cackle (appropriately dubbed the “Donald Duck effect”) that the aquanauts could scarcely understand each other. It is hoped, however, that some form of electronic “unscrambler” can be devised to demodulate and improve the quality of spoken communications.

The helium-oxygen atmosphere provided some other unexpected surprises. For instance, the heating elements on the electric stove did not turn red, and a number of the aquanauts ruefully nursed burned fingers after touching the hot metal. Further, under the high pressure of the gas mixture, water does not boil—but it does reach a temperature of more than 300 degrees. And the same high-pressure environment caused food tins that were packed under normal atmospheric pressure to crumple as if squashed by some giant, unseen hand.

High on the list of irritants and frustrations was electronic gear and scientific apparatus that performed perfectly in topside testing but either failed completely or malfunctioned when employed on the bottom. Watertight integrity was another problem; water seeped into equipment packaging with almost insidious regularity.

But it was the intense cold (down to 45° F) both inside and outside the habitat, coupled with the Stygian gloom that could be penetrated only a few feet by the most powerful underwater lighting, that most depressed the aquanauts in mind and body.

Commander Carpenter, who engaged in many of the skin-diving activities outside the chamber, reported that the SCUBA equipment should certainly include heating elements for the comfort of the swimmer, plus a compact sonar gear to assist the aquanaut back to the habitat. In the murky darkness, Carpenter experienced considerable difficulty in his directional orientation and in finding his way back to *Sealab*.

### **Results of the experiment—an appraisal**

Despite the rigors and discomforts (including several painful stings by scorpion fish) of the 45-day-long endurance test, the aquanaut teams emerged in surprisingly good physical condition.

As Arthur J. Coyle of the Battelle Memorial Institute, writing in the May 1966 issue of the *Battelle Technical Review*, put it: “The vast amount of information and experience gained during *Sealab II* experiments will be invaluable in attaining access, in the future, to the continental shelves. However, work must be done in many disciplines to understand and apply the information and thereby achieve the deep-water operating capability that is

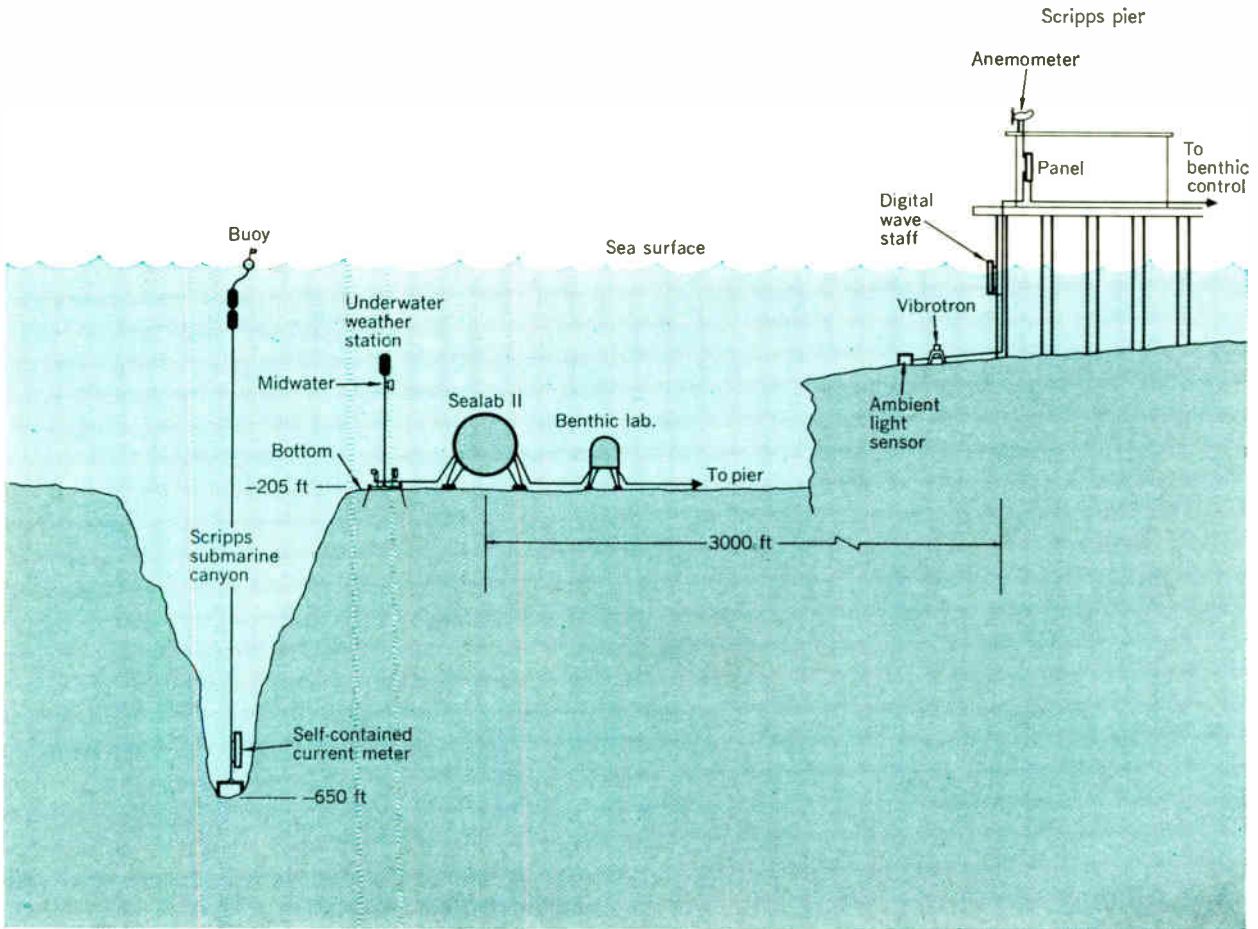
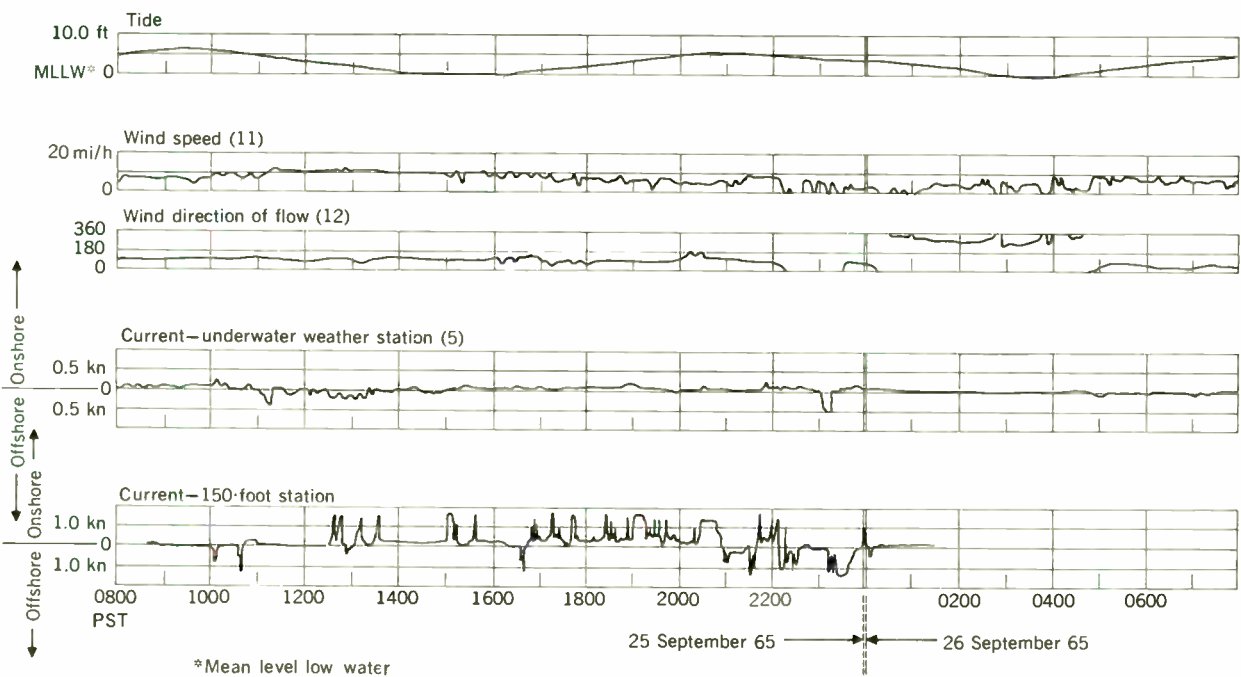

Fig. 8. Schematic profile of "Sealab II" experiment, showing location of the habitat, benthic control centers, and instrumentation vital for data acquisition.

Fig. 9. Analog records of data from "Sealab II" experiment recorded on September 25 and 26, 1965. Tide, wind speed, and direction were measured from the end of the Scripps pier; underwater weather station current readout is from the lower instrument package. Current readout from the 150-foot station was recorded from similar instrumentation placed by SCUBA divers.



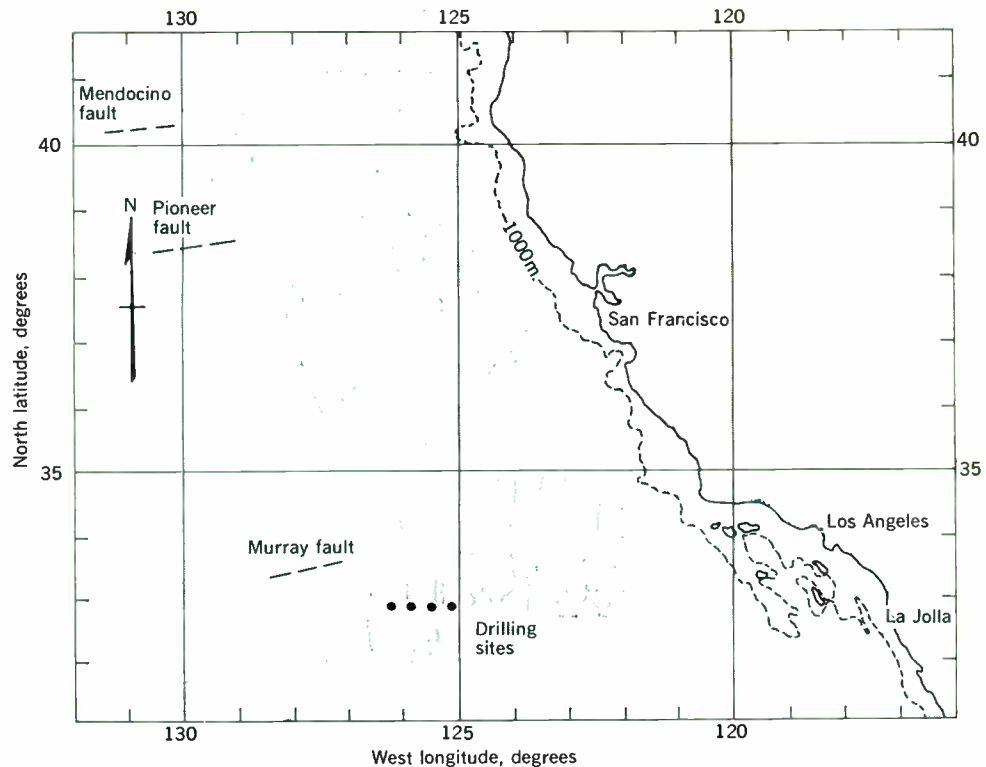

Fig. 10. Tentative sites for drilling the four preliminary holes of Project Mohole. Shading indicates areas of positive magnetic anomalies.

a prerequisite to further study and exploitation of this exciting frontier.”

Although much valuable data concerning water temperatures, salinity, sound transmission, currents, tide and wave action, etc., were accumulated, Coyle feels that the *Sealab II* experience demonstrated that there is a need for developing such items as

1. A small, dependable homing-type transducer receiver with associated sound emitters.
2. Reliable portable and fixed underwater lighting.
3. Underwater magnetic compasses, depth gauges, and watches that can be read at a glance or by touch.
4. Silt-stabilizing polymers, with associated dispensers, to eliminate or reduce turbidity created at bottom work sites.

Finally, the aquanauts reported that the performance of the pneumatically driven impact wrench and coring device (adapted by Battelle engineers for use on the sea bottom) was good, but that environmental factors prevented them from carrying out, on the ocean bottom, all of the functions of which comparable tools are capable on the surface.

As a financial footnote, the cost of *Sealab II* was \$1.48 million—exactly ten times that of *Sealab I*.

#### Where do we go from here?

*Sealab II* was merely the second stage in the U.S. Navy's Deep Submergence Systems Program; preparations for *Sealab III* indicate that the habitat depth will be about 400 feet. Perhaps Captain Bond best expressed the

future problems and aspirations of the man-in-sea projects when he observed: “May I say that when we leave the depth of 205 feet and go to a depth of 400, or greater, we must leave behind all of the equipment which we used before. Up until now... we could take items off the shelf and modify them and they would work. We are no longer in that ball park, unfortunately, so that... any piece of equipment which we used before cannot be used again... We need new methods of gas purification... new instrumentation for detection... new means of refrigeration... brand new diving equipment... And on and on.”

#### Project Mohole

One of the most fascinating and ambitious submarine projects, presently in the planning stages, is the National Science Foundation's Project Mohole. The objective of Mohole is to drill through the Mohorovicic discontinuity (Moho), the boundary surface between the earth's crust and the denser, underlying mantle. The eventual Mohole drilling site will be located approximately 170 miles east northeast of Honolulu, under 15 000 feet of water in a bathymetric area known as the Hawaiian Arch, at which point the mean depth to the earth's mantle is about 10.4 km (34 150 feet) below sea level. This is slightly less than the average for the Pacific Ocean basin.

If the Mohole drilling is eventually carried out, scientists foresee the unlocking of a huge new vault of information and evidence bearing on the very creation of this planet, the elementary composition of the earth's core and mantle, the magnetic and gravitational fields, and the



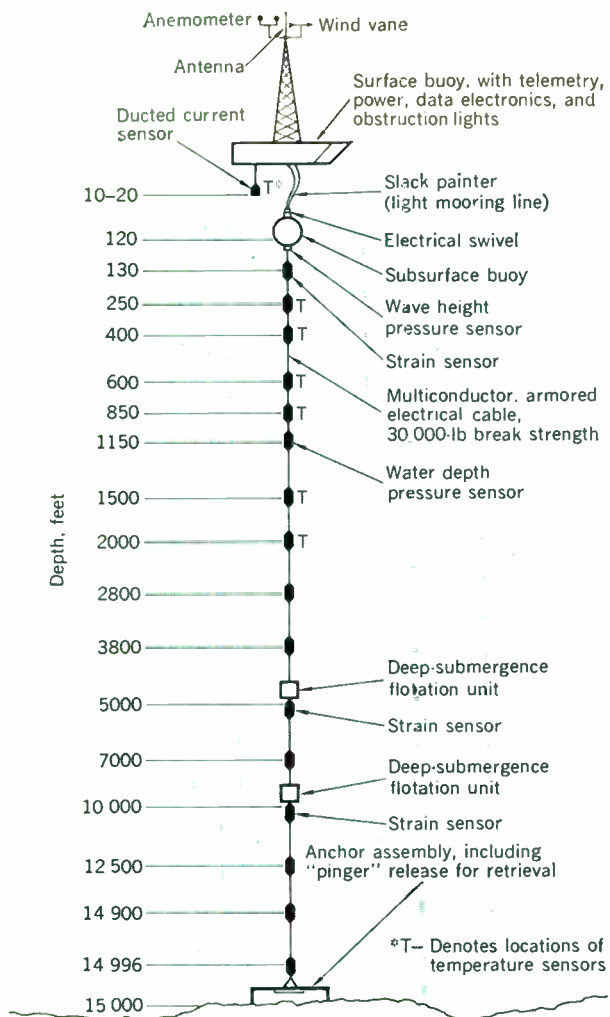

Fig. 11. Diagram showing a typical single-moored array of instrumentation for the data-gathering system that will be necessary prior to the drilling at the Hawaiian site.

vast, planetary "heat sink" that acts as a global thermostat in our climatic environment.

**The preliminary drilling.** Last winter, the Mohole Advisory Committee of the National Academy of Sciences met with representatives from both the National Science Foundation and Brown and Root, Inc., the prime contractor. At that meeting, plans were advanced for drilling at a preliminary site (Fig. 10) about 400 miles west of Los Angeles to attain specific scientific objectives during the engineering test period of the Mohole drilling platform. The four holes indicated in Fig. 10 will be drilled to a depth of about 300 meters (985 feet). Since hole re-entry will not be feasible, this is about the maximum depth that can be attained with one bit.

The preliminary drilling may provide evidence to prove, or disprove, the theory that the ocean floor is spreading and long, linear magnetic anomalies are generated in the process; and further, that this spreading is related to and coupled with reversals of the earth's magnetic field.

The scientists hope to acquire factual information on

1. The geological age of the oldest sediments lying upon the harder rock of the secondary layer of the oceanic crust.

2. The age of the top of the second layer. This will be accomplished by radiometric methods.

3. The question of whether, on magnetic positive and magnetic negative residual anomalies, the remanent magnetization of the rock is normal and reversed, respectively.

**Data-gathering system for Mohole.** Marine Advisers, Inc., of La Jolla, Calif., was retained to provide an oceanographic data-gathering system at the proposed drilling site in the Hawaiian group. Figure 11 shows a typical single moored array from the surface down to a bottom depth of 15 000 feet. Basically, it would consist of a surface buoy, a "taut-wire" mooring system, and an array of oceanographic and meteorological sensors.

The surface buoy would house recording and telemetering equipment, and would serve as a platform for meteorological sensors. It would be connected by a slack cable to a subsurface buoy, which, in turn, can be anchored to the bottom by the taut cable. The original plan was to have current sensors (indicating both speed and direction) spaced at 17 levels between the surface and the bottom, seven temperature sensors in the depth level range from 250 to 2000 feet, and a wave sensor.

All of the sensors would feed information into a magnetic tape recorder where it could be available for telemetering to a shore station on command. Depending upon the frequency with which data were recorded, the system would be able to operate unattended for a period of up to six months.

The data thus obtained could be used primarily to provide a complete and accurate picture of the ocean environment to engineers for designing the final Mohole rig. But it is also anticipated that the system would remain in operation to monitor oceanic conditions as the drilling progresses. In addition to its primary purpose, the data-gathering system should be of vital interest to oceanographers in general, since it would be the first program of detailed observations attempted at such depths.

**Present status of Mohole.** According to advice received from the National Science Foundation, as of this writing, the necessary appropriations for Project Mohole have been turned down by Congress, and prospects for the eventual approval of the venture seem quite dim.

#### Of things to come

At this point the writer will "blow all ballast" and come up for air before plunging into the final article, which will take up the instrumentation and techniques for tracking the migratory patterns of schools of food fish, a summation of the diverse applications of deep-diving submersibles, and a critical evaluation of the United States' efforts in oceanography and ocean engineering.

Figure 6 is reproduced by courtesy of the Wood's Hole Oceanographic Institution.

#### REFERENCES

1. Pritzlaff, J. A., and Shenton, E. H., "The manned submersible—A way to do undersea work," Internal Rept., Westinghouse Electric Corp., Underseas Div., Baltimore, Md.
2. Anderson, V. C., "Vehicles and stations for installation and maintenance of sea-floor equipment," *IEEE Spectrum*, vol. 1, pp. 104-108, Nov. 1964.
3. Carpenter, M. S., "Man in space and man in the sea," *Astronautics & Aeronautics*, vol. 4, pp. 32-35, Apr. 1966.
4. Murray, E. A., Inman, D. L., and Koontz, W. A., "Sealab underwater weather station," Scripps Institution of Oceanography, University of California, La Jolla, Calif., to be published in *Trans. of the Symposium on Man's Extension into the Sea*.

# Prime-mover response and system dynamic performance

*Power system load and frequency control are highly dependent upon prime-mover response and governing characteristics; which also play a major role during emergencies if portions of power systems are left with large unbalances between generation and load*

C. Concordia, F. P. deMello, L. K. Kirchmayer, R. P. Schulz

*General Electric Company*

**Prime-mover response characteristics are influenced by the dynamics of turbines, boilers, and hydraulic systems, as well as by such control devices as speed governors and boiler-turbine controls. Some of the common types of prime-mover systems considered are the conventional single and double reheat systems, once-through units, and hydraulic turbine units. The pertinent phenomena are discussed, as are the implications of prime-mover response in the light of normal and emergency load-change duty.**

The adequacy of generation-transmission system design traditionally has been tested by its ability to withstand the first few seconds of generator power-angle oscillations following faults or switching operations in the electrical network. For this type of momentary disturbance, barring the use of fast valve action for energy control,<sup>1</sup> the normal response of prime-mover mechanical powers has usually been too slow to materially affect the critical phenomena of transient stability in networks, thus justifying the assumption of constant prime-mover mechanical power that is often made in the course of studying these phenomena. However, as a next step in reliability it is becoming common practice nowadays, with large interconnected systems, to study the behavior of interconnecting tie lines on the assumption that a generator has already become unstable and has been lost. Such studies must extend over longer time periods and include the effects of prime-mover governor control.<sup>2</sup>

As a further step beyond these types of disturbances, which involve only momentary severe unbalances between electrical load and mechanical power among one or more sources, there are the admittedly much more rare cases of upsets that result in large sustained unbalances between generation and load. The performance of the power system, the changes in load flow distribution across transmission ties, and sometimes the ability of the power system to ride through the upset, are largely dependent on the response and governing characteristics of the prime-mover systems. Close examination of this problem is indicated, particularly in cases where prime-mover responses may be significantly dissimilar in different portions of interconnected systems. Moreover, perform-

ance of the system is affected by the manner in which the spinning reserve is allocated.

The mechanism of maintaining equilibrium between prime-mover power and electrical load demands can be described briefly with reference to Fig. 1.

Load changes originate in the network because of normal switching or changing of loads or, in the case of upsets, because of abrupt loss of major generation, transmission equipment, or major load-carrying ties. These changes in electrical connected load reflect themselves instantaneously as changes in electric power among the various generating units, with an initial distribution governed by the network load flow applied to existing machine-rotor angles.<sup>3</sup>

The resulting unbalance between prime-mover power and generator electric power will cause machine-rotor accelerations or decelerations, which develop into changes in speeds and machine-rotor angles.

Restoring forces—namely, changes in machine electric powers—develop in response to angular changes between generator rotors, and oscillations in angle and electric powers are set up such that the average electric power on each unit equals its mechanical power less an amount proportional to the unit's average acceleration. These oscillations have periods varying from less than a second to several seconds, depending on the stiffness of the electrical tie between machines relative to the inertia of these machines. It is characteristic of machines that are closely tied electrically to act as an equivalent large machine; the oscillations of significance become those between groups of machines or between major power systems across limited capacity ties, with periods of up to 10 seconds. The final change in speed of all units will be arrested when balance is again restored between total mechanical power and electric load demanded by the network.

In the case of constant prime-mover power (blocked governors), this balance is obtained by virtue of the change in connected load with frequency. Typically this load-damping characteristic amounts to between 1 and 2 percent change in connected load for a 1 percent change in frequency. For this limiting situation, in which prime-mover power is assumed unchanging, the frequency

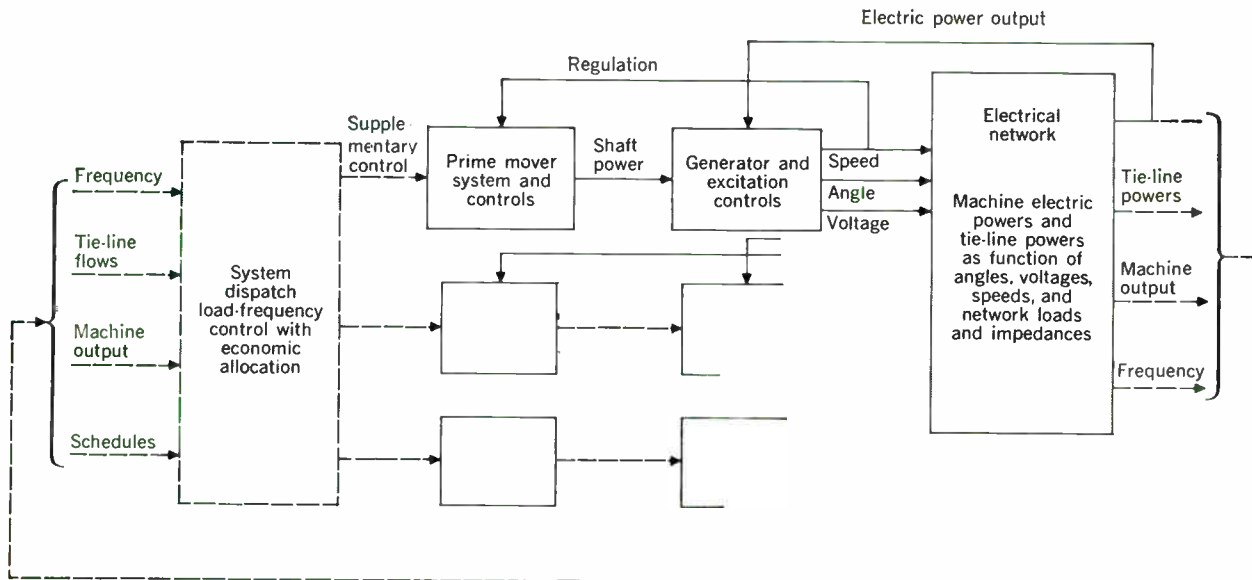

Fig. 1. Schematic diagram of power system and controls.

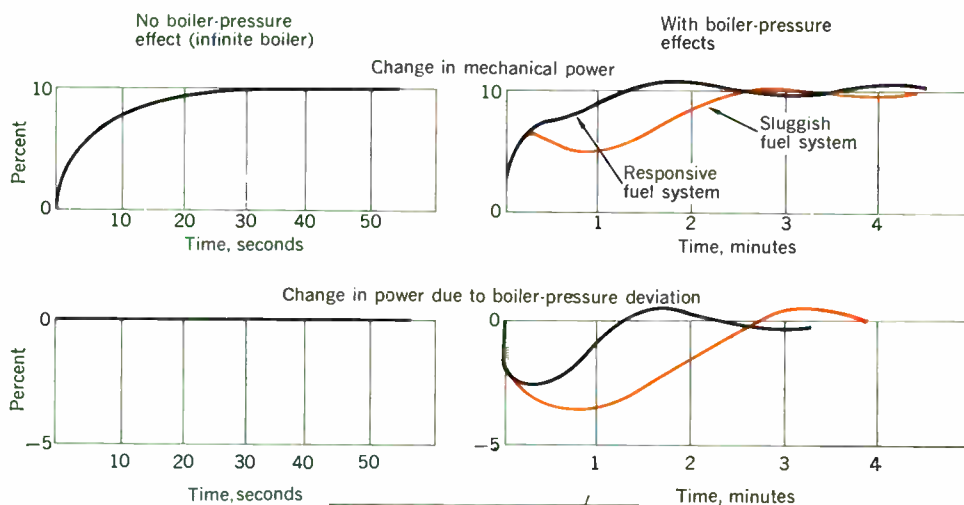

Fig. 2. Step change in speed-changer position.

transient phenomena are described entirely by the machine inertias, system load damping characteristics, and electrical tie strengths between machines. The frequency deviation will be established within 10 seconds or so, although oscillations will persist for a few seconds.

With active governors, the frequency deviation produces changes in prime-mover power and the final frequency change is primarily a function of the equivalent governor regulation, which is usually considerably more effective than the load characteristic in limiting the extent of the frequency dip. It should be noted, however, that changes in prime-mover power occur with varying delays, depending on the response characteristics of the prime-mover system.

Final control action on the prime movers is through the supplementary load-frequency control, which returns frequency and tie-line power interchange to schedule in a minute or more. This action is also affected by the dynamic response characteristics of prime-mover systems.

#### Response characteristics of prime movers

By prime-mover response we mean the time response of prime-mover shaft power to control signals calling for

changes in output. These response characteristics are influenced by the dynamics of turbines and associated energy sources such as boilers and hydraulic systems, as well as by associated control devices, i.e., speed governors, boiler-turbine controls, etc. A brief review of these characteristics for some common types of prime-mover systems follows.

**Conventional steam single and double reheat.** Generation is changed on conventional steam turbine units by moving the governor-controlled valves. In normal system operation the motion of these valves is directed by:

1. Flyball or other speed-sensor action in response to changes in unit frequency.
2. Changes in speed-changer motor position (governor synchronizing motor).

Control valve position responds very fast (in less than a second) to flyball action or to changes in speed-changer motor position.<sup>4</sup>

Assuming constant boiler pressure, turbine mechanical power in turn responds to valve position changes as follows: About 30 percent of the final change is attributable to the turbine upstream of the reheater and comes

about within a fraction of a second; the remaining 70 percent will follow with a time constant of about 5 to 8 seconds, due to the charging time of the reheater volume.<sup>5</sup>

Figure 2 shows a response of turbine mechanical power following a step change in turbine valve for this ideal case of constant boiler pressure. Since the steam source is not infinite, boiler pressure does suffer deviations that affect the steam flow and mechanical power. Figure 2 also shows a typical response trace for a drum-type unit and includes the effects of boiler-pressure deviations and subsequent pressure restoration by combustion controls. The fast pressure-control performance shown is approximately the best that can be obtained in coal-fired units with no dead time in fuel systems. It is more representative of oil- and gas-fired units, since many coal-fired units have considerably slower pressure controls. The slow pressure-control performance shown is typical of certain coal-fired units with significant fuel-system lags.<sup>6</sup>

The effect of double reheat is to add a second lag of 5 to 8 seconds to the portion of mechanical power developed in the turbine downstream of the second reheater.

In most conventional steam units, changes in generation are initiated by turbine control valves and the boiler controls respond with necessary immediate control action upon sensing changes in steam flow and deviations in pressure. Energy is transiently drawn from or put into

boiler storage since the inputs to the boiler are relatively slow in relation to the speed of turbine valve movement.

**Once-through units.** The basic difference between the response of once-through units and that of conventional drum-type units lies in the method of coordinating the control of the boiler-turbine unit. The somewhat lower stored energy in the once-through boiler and the requirement of closer coupling between firing rate and feedwater flow have led to the use of greater caution in control of these units with the evolution of varying degrees of coordination between the turbine load demand and the inputs to the boiler.<sup>7,8</sup>

The development of more sophisticated boiler controls will probably permit obtaining response characteristics from once-through units that are comparable to if not better than those of conventional units. However, to date the coordination between turbine and boiler has involved use of the turbine valve in part as a boiler-pressure regulator. Turbine valve motion is inhibited in order to limit boiler pressure deviations, thereby slowing the response of turbine power.<sup>9</sup>

A common type of coordinated once-through boiler-turbine control is shown functionally in Fig. 3(A). To achieve the coordination between boiler variables and turbine demand, it is necessary to make the speed-changer motor respond to intelligence other than and in addition to load control signals. This is done by integrating the load-frequency control pulses to develop a signal indicative of demand for megawatts that can be altered by other inputs. This signal is modified by a frequency-deviation bias matching the unit's governor droop characteristic to develop the desired megawatts. Without this bias the MW feedback loop would undo whatever motion of turbine valves might have occurred as a result of governor action. Comparison with the unit's actual output develops the MW error, which is sent with the desired MW signal to the boiler controls. Turbine speed-changer position is directed to reduce a combination of MW error and pressure error to zero; the boiler controls are similarly directed to reduce the pressure error biased by the MW error to zero. The sense of the cross-coupled MW-error and pressure-error biases is in the direction such that a positive MW error (MW lower than demand) would cause the turbine valve to open and the boiler controls to call for more feedwater, fuel, and air, whereas a positive pressure error (pressure lower than set point) would call for closing of the turbine valve while simultaneously increasing the feedwater.

Figure 3(B) shows response characteristics for varying degrees of coupling between MW and pressure error.

**Hydraulic turbine units.** Hydraulic turbine power plants have an inherent characteristic (inertia of the water column) that causes them to have shaft-power responses much slower than those in a steam turbine.

Because a change in the position of the gate at the foot of the penstock produces an initial short-term turbine-power change that is opposite in sense to that sought, hydraulic turbine governors are designed to have relatively large transient droops with long resetting times in order to obtain stable frequency regulation under isolated operating conditions. Consequently, the response of a moderate-head hydraulic turbine plant to speed changes or to changes in speed-changer setting is relatively slow, as shown in Fig. 4.

**Response limitations.** In large interconnected systems,

Fig. 3. Coordinated boiler-turbine control used on some once-through units. A—Schematic diagram of controls. B—Response characteristics.

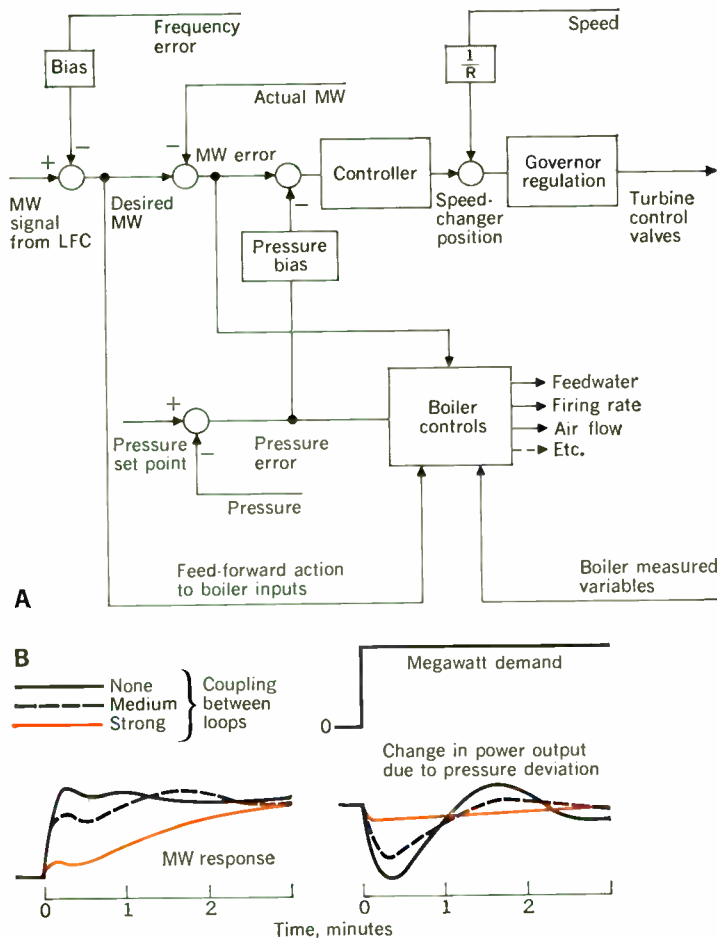

the normal instantaneous changes in connected load are a very small percentage of the total capacity; hence, frequency changes are small and the speed-governor action is normally an imperceptible ripple. Generation is usually changed manually or through automatic supplementary control. By either method, the rate of change normally does not exceed 3 to 5 percent of machine capacity per minute; on the large new steam units, it is often limited to less than 2 percent per minute.<sup>10</sup>

During system upsets, such as system separation or loss of generation, where portions of systems may be left isolated with large unbalances of generation and load, governor action may be called upon to make large changes within a few seconds. But even though the turbine valve may be capable of responding 100 percent within this period of time, factors pertaining to boiler and turbine safety may not allow such unrestricted motion. On the way up—that is, valve-opening action—the valve motion may be limited by the turbine load limit, which can be set to ride a certain value above the operating point to prevent turbine loading above the capacity of mills, pumps, or other auxiliaries on line. In the event of very large changes, if not limited by the load limit, unit loading may be arrested by the turbine initial pressure regulator, which can be set to prevent boiler pressure from dropping below about 90 percent of rated value. This technique is used to prevent carryover of water from the boiler.

Other factors that sometimes limit the magnitude of generation change that can be made in this almost instantaneous fashion involve combustion controls which may not be designed to withstand the large upsets resulting from possible large transient mismatches in fuel and air and the attendant danger of explosions, or from the inability of feedwater controls to hold the drum level within safe limits.<sup>11</sup>

These factors, therefore, make it generally impractical to take instantaneous load changes greater than 20 percent on large, conventional steam units; in fact, some units cannot withstand instantaneous changes greater than 10 percent.

In the case of once-through units using the coordinated-control philosophy, it is usual to limit the maximum rate at which load demand can change, either upstream or downstream of the point where the frequency bias signal is injected. The unit response to governor action following frequency upsets would be faster for the case where the rate limit is on the MW demand signal upstream of the injection point.

Hydro units usually have no intentional response limitations, since the plant equipment is often protected by the inherent limits of speed-changer maximum rate and governor transient droop.

It should be noted that large changes on a given unit imply that reserve has been concentrated in a few units. If brought about by governor action, these large changes in power would require too large a frequency deviation. To reduce the frequency deviation, special control signals would be required.

### Performance under system governing and load control

The significance of prime-mover response effects on power system dynamic performance may be illustrated by examining transient action following abrupt load

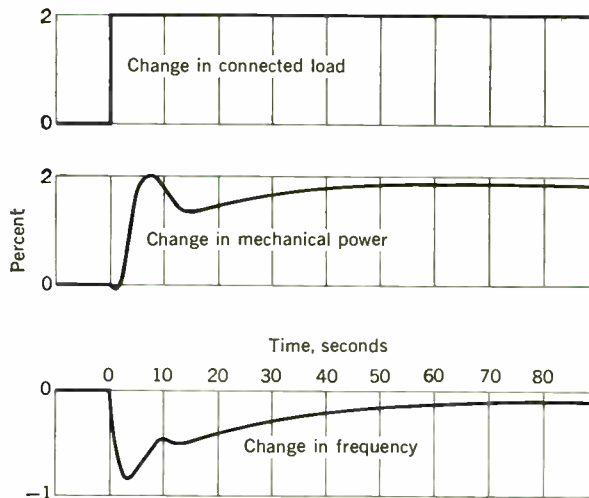
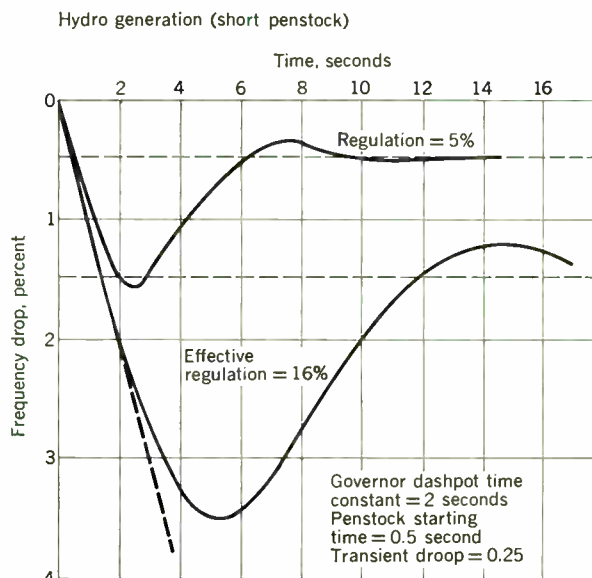
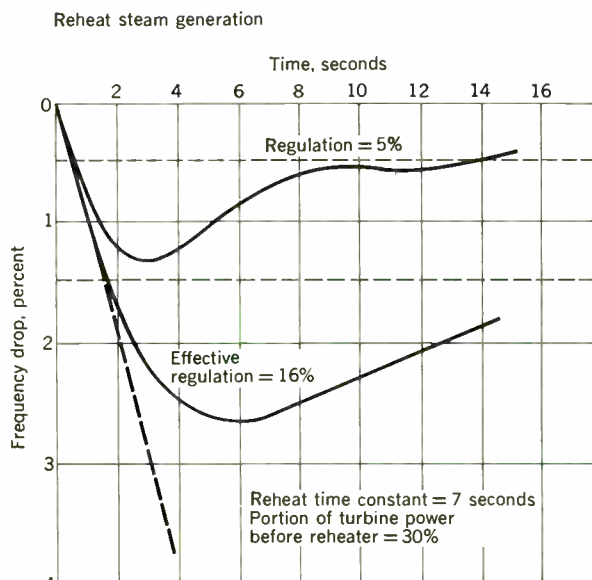

Fig. 4. Response of isolated hydro generation to change of load. Permanent droop = 5 percent, temporary droop = 50 percent, transient droop time = 20 seconds.

Fig. 5. Frequency drop on loss of 10 percent generation in isolated system.



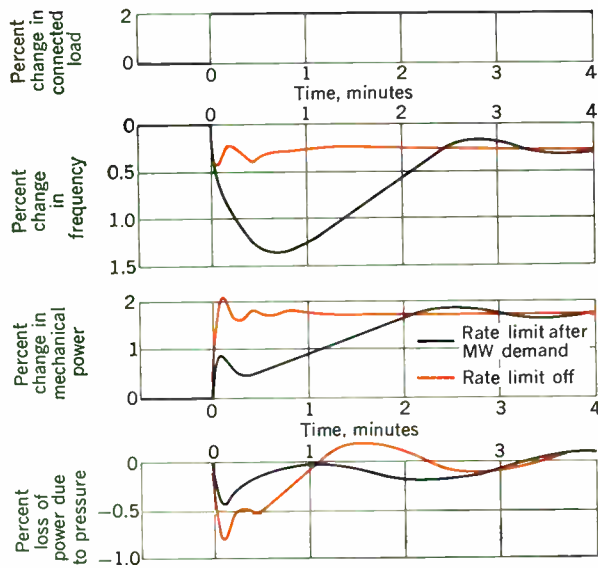

Fig. 6. Effect of 2 percent increase in connected load on reheat steam generation system with coordinated controls. Effective regulation in area = 16.7 percent.

Fig. 7. Load change on isolated area.

changes in certain limiting situations. One of these situations is the case of an equivalent single unit supplying an isolated load. This case approximates conditions where the bulk of power generation in an isolated area is of the same type. Another case of interest is an isolated system with prime movers of dissimilar characteristics. Additional cases explore effects of prime-mover characteristics in a system tied to a very large interconnected pool.

**Single equivalent unit in an isolated area.** The case of a single equivalent unit in an isolated area is often studied to determine the responsiveness of power generation in limiting frequency excursions following a large upset that results in the area under study being separated from the large power grid.

Figure 5 shows the frequency deviations for the case of a load increase in an isolated power system with different types of generation and varying amounts of effective regulation. Only governor action is being considered, since the slower resetting of frequency deviation to normal through supplementary control is of secondary significance in terms of affecting maximum deviations.

The maximum deviation in frequency can be much greater than the final value. This is shown in Fig. 5, which depicts frequency transients following a loss of generation for a typical reheat steam system and a typical hydro system. It can be seen that the ratio of maximum deviation to final deviation of frequency is related to the value of steady-state regulation and is amplified by lags in the response of the prime-mover system.

The frequency transient initially follows the response determined by system inertia, as can be seen by noting that all curves near time zero approach asymptotically the curve of deviation that would occur with blocked governors.

The effective regulation is inversely proportional to the number of units in governing range. The results show the

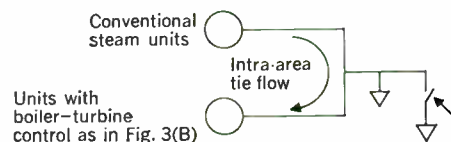
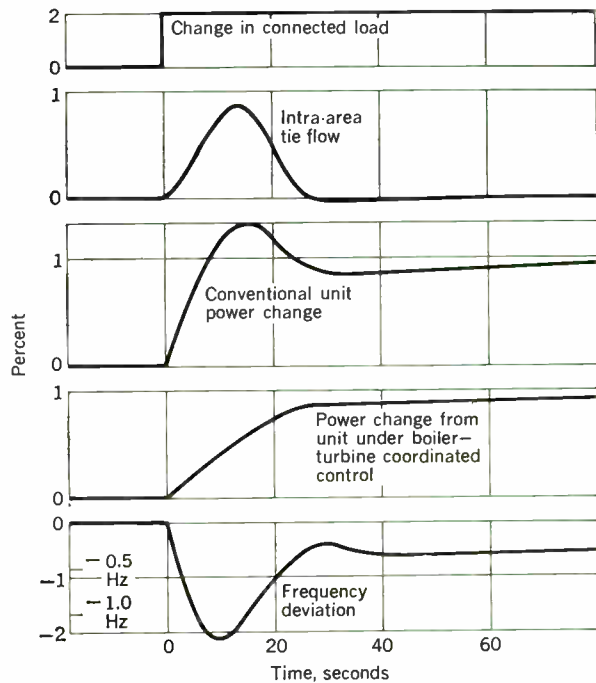

advantages of distributing regulation through many units by keeping their governors active.<sup>12</sup>

Figure 6 shows the performance that would result for the case of an isolated system composed of steam generation with coordinated boiler-turbine controls such as those advocated for once-through boilers,<sup>13</sup> see Fig. 3(A), with response characteristics as in the middle curve of Fig. 3(B). Effects of introducing rate limiting of the MW demand signal downstream of the point where the frequency bias signal is introduced are shown in Fig. 6.

**Dissimilar units in isolated area.** The effects of having generation with dissimilar response characteristics are illustrated on Fig. 7, which shows the case of an isolated system that is supplied half by conventional reheat steam and half by units with response characteristics as shown in Fig. 3(B), middle curve.

This case illustrates the fact that the transient load-flow conditions in networks following large upsets can be very sensitive to the response characteristics of generation in the various parts of the system. Entire interconnected systems can be viewed as a huge single area, and the results of Fig. 7 have significance for this case as well. It is conceivable that, because of dissimilar response characteristics, a large load upset might result in overloading of ties in locations otherwise considered remote from the location of the upset.

**Load changes in an area interconnected with a large pool.** Although the examples cited are pertinent for the case of an upset that is large relative to the total interconnected system capacity, a more common occurrence is that of an upset that is small relative to total interconnected system capacity, though not necessarily small

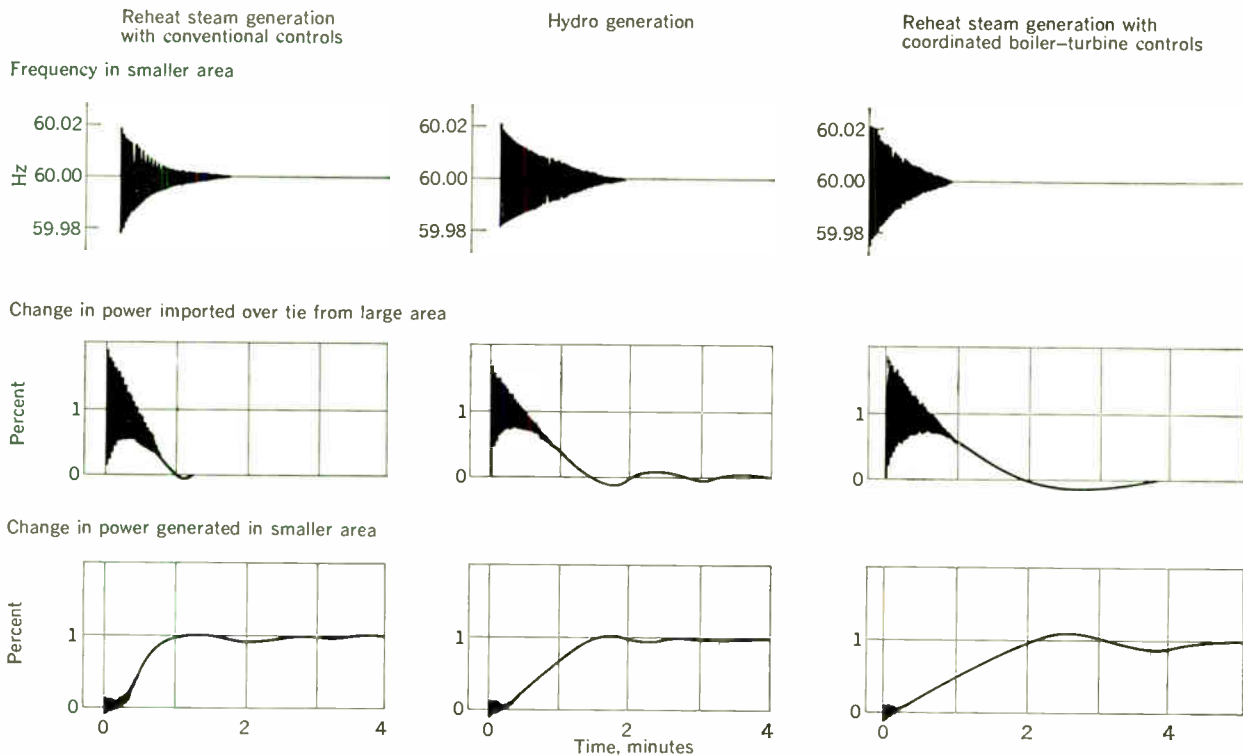

Fig. 8. Effect of load increase in area tied to much larger interconnection.

relative to the utility in which it occurs. In these cases the frequency deviation is small, with the bulk of the load change being supplied by the large interconnected capacity. Restoration of balance within the utility must rely on relatively slow supplementary control action (correction of load change within a minute or more).

Figure 8, which puts into perspective the phenomena for this case, shows the load change being initially supplied by the interconnecting ties and then being corrected by supplementary control. It also shows the range of response to be expected as a function of the type of prime-mover system. In the case of the reheat steam generation with coordinated boiler-turbine controls, the adjustments are as in Fig. 3(B); strong cross-coupling with the pressure control loop is employed.

### Conclusions

The effects of prime-mover response on system dynamic performance have been illustrated in the light of several typical situations that can arise in power system operation. Recognition of these effects will become of increasing importance in the planning of transmission capability between systems or parts of systems.

Closer attention to the response capabilities of various units and to the spreading of the governing duties as uniformly as possible among many units will be significant in reducing the severity of system upsets. In particular, boiler-turbine controls should be designed to avoid unnecessarily restricting the response of units beyond the inherent limits imposed by thermal stresses and safety of plant equipment.<sup>14</sup>

Essentially full text of a paper presented at the American Power Conference, Chicago, Ill., Apr. 26-28, 1966.

### REFERENCES

- deMello, F. P., Ewart, D. N., and Temoshok, M., "Turbine energy controls aid in power system performance," presented at the American Power Conf., Chicago, Ill., Apr. 26-28, 1966.
- Concordia, C., "Dynamic concepts of interconnected systems," presented at the 18th Annual Southwestern IEEE Conf., Dallas, Tex., Apr. 20-22, 1966.
- Concordia, C., "Effect of prime mover speed control characteristics on electric power system performance," *IEEE Paper 31CP65-778*, 1965.
- EGgenberger, M. A., "Power response of modern reheat turbine generators to load dispatching signals," *ASME Paper 65-WA/PWR-5*, 1965.
- Concordia, C., "Effect of steam-turbine reheat on speed-governor performance," *ASME Paper 58-A-36*, 1958.
- Stephens, W. M., deMello, F. P., and Ewart, D. N., "Simulation as a design tool for Plant Jack McDonough boiler controls," *Proc. 7th Nat'l Power Instrumentation Symp.*, vol. 7, pp. 35-46, 1964.
- Argersinger, J. I., Laubli, F., Voegeli, E. F., and Scutt, E. D., "Development of an advanced control system for supercritical pressure units," *IEEE Paper CP63-1409*, 1963.
- Durrant, O. W., and Loesser, J. K., "Boiler turbine control system for application to universal pressure boilers," *IEEE Paper CP63-1410*, 1963.
- Morgan, W. S., and Grimes, A. S., "Load frequency control of supercritical units on the AEP System," *IEEE Paper 31CP66-59*, 1966.
- IEEE Committee Report, "Power plant response," *IEEE Paper 31TP65-771*, 1965.
- O'Brien, J. T., "Dynamic testing of power plants," *Proc. 6th Nat'l Power Instrumentation Symp.*, vol. 6, pp. 105-112, 1963.
- Concordia, C., "Performance of interconnected systems following disturbances," *IEEE Spectrum*, vol. 2, pp. 68-80, June 1965.
- Grant, I. E., Shuss, J. A., Hottenstine, R. H., and Daniels, J. H., "Automation of Bull Run Unit No. 1," presented at 11th Annual Southwestern ISA Conf., Chattanooga, Tenn., Apr. 27-29, 1965.
- Summer, J. C., deMello, F. P., Ahner, D. J., and Dyer, C. E., "Analysis and design of controls for a once-thru boiler through digital simulation," presented at the 9th Nat'l Power Instrumentation Symp., Detroit, Mich., May 16-18, 1966.

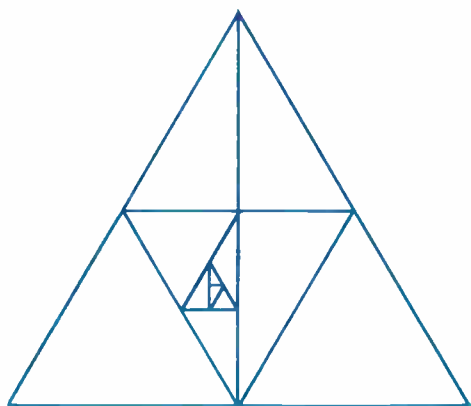

## The philosophy of engineering

*There is a close interrelationship of three vital aspects of engineering philosophy: the essence of engineering, the methodology, and engineering education*

*Henry Greber*    *New York, N.Y.*

Although the philosophy of science was already well developed in antiquity, the philosophy of engineering is not accurately defined even today! Despite the influence of engineering upon philosophy in recent centuries, no one philosopher has made an attempt to define the philosophy of engineering. Thus it may not be a coincidence that Ludwig Wittgenstein, the founder of the modern philosophical trend of logical positivism, was an engineer. But even he never wrote anything on engineering. It seems as if the philosophers left the philosophy of engineering to the engineers.

Historically, engineering evolved from craft; it was based upon experience and had little to do with science. Just as the horse-drawn buggy was replaced by the automobile, so was the buggy maker replaced by the modern engineer. Similarly, the ancient wine maker was replaced by the contemporary chemical engineer who still relies—but to a decreasing extent—on the know-how of the ancient wine maker. Modern engineering applies practical experiences even though they may not be understood scientifically. The quantitative knowledge of involved physical phenomena is important, but if it is not available, it can be replaced by suitable empirical approximations for engineering purposes.

### **The Greeks had a word for it**

The close connection between engineering and craftsmanship is in conformance with the Greek concept of *techne*—practical knowledge used for the purposeful formation of matter to serve man's needs. The Greek word *logos* means science. These are the two roots of the word "technology." A striking feature of the ancient Greek civilization was the separation of theoretical science (*theoria*) from practical knowledge (*techne*). The latter was the unwritten skill passed from the craftsman of one generation to the apprentice of the next. *Theoria* was meant only for the delight of the intellect in contemplation.

### **The essence of engineering—an historical overview**

An essential aspect of the Hellenic civilization was that the ancient Greeks held themselves to be above manual labor, which was performed for them by slaves. Not only did the Greeks disdain manual work, but also they were



ashamed of being interested in it. Archimedes apologized for his inventions in his writings. He claimed to have made them only for amusement.

Plato considered the use of geometry for land measurement to be an undue vulgarization of science. Although glass was known in ancient Greece, and used for many household items, the Greeks never devised a lens. Consequently, they never invented a microscope or a telescope. Why did they not develop these devices that are so essential to the studies of biology and astronomy? The answer is that in ancient Greece, science was in the hands of philosophers who were too proud to learn anything from nonphilosophers—let alone from slaves making glassware.

Thus, through their contempt for manual labor, the Greeks of antiquity divorced themselves from reality. The absence of an immediate contact with the physical surrounding—and particularly the almost total lack of experimentation—is the principal weakness of Greek classical science. This may have been the prime reason for the eventual downfall of the ancient Greek civilization.

**Leading questions—partial answers.** What is the essence of engineering? What is its purpose, and the means and methods leading to it? Such considerations are usually initiated by consulting a dictionary in which engineering is described as “an applied science that utilizes materials and physical forces for the production of structures, machines, equipment, and manufactured items. All these serve for the satisfaction of human needs.” Although this description may well explain the *meaning* of the word “engineering,” it is insufficient in expressing the essence of engineering. This essence is not easy to describe.

In a report, presented in 1951 at an engineering conference in The Hague by a task-force committee that had worked on it for two years, the definition of engineering is expressed in 300 words—much too long to be quoted here. A short definition, such as “engineering is the art and science by which matter and energy are used for the benefit of mankind,” is far too general to reveal the essence of engineering. In lieu of this, the writer would suggest another definition:

*Engineering is the skill of utilizing knowledge, acquired from science and from practical experience, to produce devices for the use of mankind.*

The products of engineering, although they may serve for the *use* of mankind, are not necessarily for its benefit. For example, engineering in ancient Rome was a military craft. The word “engineer” is derived from the Latin *ingeniator*, which means the one who invents *ingenia*—war machines. Even today, products such as alcoholic liquor, tobacco, and some drugs, manufactured or processed by engineering skills and techniques, are of questionable benefit to mankind.

**The merger of ‘*techne*’ and ‘*theoria*.’** Today, the separation between practical and theoretical knowledge is only formal. There is a continuous shortage of available theoretical knowledge that is badly needed in engineering. Many engineering problems must be solved in spite of the fact that the theoretical knowledge for their solution is not yet at hand.

Even though the modern concept of engineering has been with us for a few centuries, it is still in the process of formation and fusion. Some branches of engineering, such as electronics and aeronautics, have existed only for a few decades. Older branches of engineering are drastically changed as new scientific discoveries are made. It is, therefore, not surprising that no precise definition of engineering can be given today, and many different definitions and redefinitions can be expected in the future. Nevertheless, the essence of engineering—its reason for being—will remain unchanged.

**The goals and the methods.** The goal of engineering is to provide goods and services to mankind; its method in pursuing this goal is to apply scientific or any other available, verified knowledge. The goal of engineering is economical; its method is scientific. The goal and the method clearly place engineering in a position between economics and science.

### **The method of engineering**

**Problem solving.** There is a characteristic procedure in the solution of engineering problems that can be broken down into six cardinal steps:

1. Recognition of the economical need.
2. Formulation of the problem.
3. Breaking down the problem into concepts that will suggest a solution.
4. Finding elements for the solution.
5. Synthesizing the solution.
6. Simplifying and optimizing the solution.

**Neither deductive nor inductive.** The engineering method is neither deductive nor inductive; it starts from facts known either to science or from practical experience, and these facts are applied for the solution of an essentially economic problem. Technological devices are not derived from this knowledge; rather, they are invented so that the knowledge can be applied.

There is often more than one scientific principle that can be used for the solution of a given engineering problem, and there is also more than one engineering problem that can be solved by the application of a given scientific principle. Thus there can be *more than one answer* to an engineering question. Conversely, there are many engineering questions to which the same answer can be given.

**The direct solution.** Some solutions are more direct than others. The most direct solution, which is the simplest (and usually the best), can be found by an incisive formulation and reformulation of the problem. This can be done only by finding its underlying economics.

By way of illustration, consider the problem of a river crossing. Here, the primary objective is not to build a bridge, but to get to the other side of the river. This can be done in many ways: by ferry, cableway, underwater tube, helicopter, etc. Which means do we choose? This depends upon the economics of the problem, because getting to the other side of the river is not the final objective: there must be a *reason* for being on the other side of the river. Perhaps this reason is to extract ore from a mine, to farm land, or to build a suburb. It is only when the ultimate economic objective is known that it is possible to find a direct solution to the problem, provided such a solution exists at a given level of science.

**Criteria for problem solving.** Although there is a standard approach to the solution of engineering problems, the solutions themselves must fulfill a set of standard requirements that includes safety; reliability; long-term economy; a minimum of labor; practicality in ease of manufacture, installation, operation, and maintenance; and esthetic design, insofar as possible.

In the majority of cases, all of these criteria cannot be satisfied at the same time. Therefore, the final engineering solution has to be a compromise.

The safety requirement dictates the need for the thorough checking of any engineering work and the continual testing of components during construction and manufacture. The primary reason for this is that an engineering mistake may endanger life and property. A secondary reason for caution is that an engineering work is predicated upon many assumptions, some of which may be conflicting. Thus the compatibility of these assumptions, and their influence upon the end result, must be constantly investigated. It follows, therefore, that to compromise some conflicting assumptions and to optimize intermediate results, reiteration is indispensable.

The engineering assumption is an inductive step, generalizing features that are found in many similar devices. The experienced engineer is expected to be able to make correct assumptions. In fact, this ability is what makes the difference between the experienced and the inexperienced engineer. But correct assumptions also must be optimized and coordinated to suit the project at hand, so that even the experienced engineer must check and recheck his computations and designs as he proceeds in his work. As a measure of the advancement of science,

however, the engineer of the future will undoubtedly depend less upon his assumptions; yet, he will never eliminate them altogether.

Making assumptions is not unique to engineering. In science, assumptions (or hypotheses) are formed first. When these hypotheses become experientially verified, the hypotheses become scientific theories.

**Synthesis and analysis.** Engineering effort is best described by the words *designing* and *inventing*. The difference between them is quantitative rather than qualitative. The terms imply “putting parts together so that they can work together”—or, more precisely, that natural forces can work through these parts to satisfy human needs. The engineering method is synthetic; scientific work is usually analytic, but it can be also synthetic.

In conclusion, although there is certainly a pattern in solving engineering problems in which specific methods are used more often than others, *there are no unique features that distinguish the engineering method from methods used in other branches of human activities*. The scientific method is used in engineering as far as possible, but it cannot be used far enough. In general, the engineering method is far less rigorous than the scientific.

### Engineering education

The work of an engineer, at least in its methodology, resembles that of the physician and the attorney. In these professions, a body of generalized theories is applied to particular cases. But although there is relatively little discussion concerning the education of physicians and lawyers, engineering education seems to be the subject of continual, worldwide discussion. The global consensus is that engineers are not as useful as they might be—or even as they should be.

**The elements of engineering.** Since engineering is the application of scientific and practical knowledge to economic ends, it consists of three elements:

1. Engineering know-how, or technology.
2. Scientific knowledge.
3. Knowledge of economics and of business conditions.

It is only by possessing these three kinds of knowledge that the engineer can fulfill his function. Technology is the engineering science proper. Within it, machines, apparatus, and equipment and its components are subject to scientific classification and investigation. It is interesting to note in technology that the scientific method used for the investigation of natural phenomena is applied to study man-made means for harnessing natural phenomena.

**The ‘weak spots.’** It has been alleged that the engineer is not sufficiently equipped with a knowledge of science and economics, nor even with the proper degree of technological knowledge. Much of the latter remains to be acquired by him on his first jobs.

Ideally, the future engineer should learn in school that which he will be asked to do in his actual work. The contemporary engineer cannot talk with competence on science since he is not a scientist; neither can he talk with authority on economics since he is not an economist. As already stated, since his knowledge of technology depends largely on his job experience, there can be but one conclusion: *Engineering education must be upgraded.*

**The upgrading process.** All trades and professions, including engineering, are involved in a continuous process of upgrading. The urgency of improving engineering education is based on the following premises:

1. The explosive growth of science.
2. The rapid growth of technology.
3. The increasing complexity of economics.
4. The desire of industry to reduce the long apprenticeship period of the engineer.

‘Creative engineering.’ It is surprising that creative engineering, which encompasses the devising of new design concepts and inventions, is not taught at all as a part of the regular curricula in engineering schools. A few courses on this subject are conducted, on a highly experimental basis, in some colleges, but these are the exceptions.

From the preceding analysis, it can be seen that imaginative synthesis is the very essence of engineering. As Herbert Hoover, the engineer President of the United States, put it: “Engineering without imagination sinks into a trade.” Thus the lack of creative engineering in the curricula of the majority of our colleges and universities seems to do little to upgrade the engineering profession. Further, the lack of sufficient knowledge in technology, science, and economics often prevents engineers from assuming positions as captains of industry.

#### **Status of engineering in the modern society**

The purpose of engineering is to satisfy the economic needs of society; it is not the engineer’s responsibility to decide whether or not these needs have to be satisfied. If the engineer had the final say as to whose needs should be satisfied and to what extent, and what should and should not be done, he would be practically in control of society. This would contradict the principle of democracy, according to which the control of society belongs to society itself. It does not mean, however, that the engineer is not responsible for what he is doing, for there are moral values that cannot be violated. The engineer must respect these moral values and be responsible for his work, just as the lawyer and the physician are responsible for theirs. On the other hand, the engineer cannot be solely responsible for all the sociological aspects of technology since he shares this responsibility with society in general.

**Social position of the engineer.** Engineers have not always been satisfied with their position in society, and, in the early 1930s, the “technocracy” movement was originated. The movement’s originators, Thorstein Veblen, Howard Scott, and others, believed that because engineers and scientists contributed so much to the creation of modern civilization, society should be controlled by them. The concept of technocracy rested on the idea that the majority of social problems are those of production and distribution of goods and services. Therefore, engineers and scientists, by virtue of their education and experience, should be capable of handling such problems.

It was the thesis of the technocrats that the control of society by engineers and scientists should be based on the natural laws that govern human society, and they believed these laws could be derived from scientifically accurate measurements of social phenomena.

Although there can be little doubt that engineers and scientists have better judgment concerning some problems than those in other professions, there can also be little doubt that the idea of technocracy contradicts the concept of democracy. In a democracy, no man—no matter what his qualifications may be—can have a larger share in the control of society than that of another man.

The status of the engineer in modern society is not as high as it could be. He is not generally a leader of industry. As far as the application of scientific discoveries, such as atomic energy, is concerned, the engineer is often overshadowed by the physicist. Grand-scale engineering schemes are usually initiated by business leaders who are essentially trained in economics. To assume a leading position in industry, the engineer must have the comprehensive educational background, the skills, and the experience for such a position. Again, this can be achieved by means of a substantial upgrading of engineering education.

#### **The future of engineering**

It is certain that a considerable upgrading of the engineering profession is imminent. A powerful factor that will contribute to this upgrading is the widespread use of computers. They will free the engineer from his routine chores and make him available for more creative work.

As the role of technology grows in our contemporary era, there will be more and more creative work to be done. The history of engineering clearly demonstrates that enormous use has been made of comparatively small scientific breakthroughs.

**The ‘outer limits.’** Even the most optimistic scientist will agree that there are limits to man’s scientific penetration into nature’s citadel. There is no hope that man will ever know everything that he would like to know. Nevertheless, this limitation does not bar man’s way to mastery over certain aspects of nature. Man’s mastery over nature, through knowledge, does not imply that he will be able to run it according to his wish. This is clearly impossible. By thoroughly utilizing all of the scientific knowledge he can obtain, however, man will free himself from many of the bondages of natural forces; to that extent he will be independent of nature.

#### **Within a limited scope, a bright forecast**

Even within the limited scope of man’s mastery, fantastic achievements can be attained. In time, agriculture will cease to be a source of food, which will be chemically synthesized. The recycling of biological material and waste products, and their conversion into food, will become feasible. Chemical raw materials and water will be extracted from the sea and from the atmosphere to supplement automated, deep-level mining. Land and sea transportation will be almost completely superseded by air transportation.

By altering the climate and, to some extent, the topography of this planet, man will be able to modify his environment to suit his needs. He will travel to other planets, change their orbits, and possibly create new, artificial planets. He will be able to modify existing forms and create new forms of matter. He may even succeed in creating new forms of life. Natural laws will be the only limitation on his possibilities.

By becoming a limited master of nature, man will also become a master of his own nature. Highly developed technology will be able to satisfy all the needs of mankind. When this Nirvana is reached, the level of human happiness will be proportional to the level of engineering.

#### **BIBLIOGRAPHY**

Ver Planck, D. W., and Tcare, B. R., *Engineering Analysis, An Introduction to Professional Method*. New York: Wiley, 1952.

# Real-time digital analysis system for biological data

*J. Ryland Mundie, H. L. Oestreicher, H. E. Von Gierke*

*Aerospace Medical Research Laboratories*

**Man's knowledge of this world is gauged by the tools with which he measures it. One of the most remarkable achievements of the past decade has been development of solid-state, high-speed digital computing equipment permitting very rapid logical and arithmetical manipulations to be carried out. In the system described, a medium-size digital computer has been brought into the laboratory and made an integral part of the experiment to provide a measurement tool with unique capabilities. Although the system was designed for use in a biological laboratory, it is equally feasible for a laboratory of any discipline. The ease of control, coupled with a visual display of the computed results, have led to the appellation, a "third generation" oscilloscope.**

The dynamic nature of a living system requires rapid measurement and processing of multiple variables. Many experiments cannot be conducted under precisely controlled conditions, and it is necessary to measure and describe both independent and dependent variables simultaneously. This produces large quantities of data in a short period of time, but the usefulness of the information is seriously limited by the capacity to analyze it. An instrument that can accept and digest large volumes of data and present results quickly, in an easily comprehensible format, opens new fields of investigations to the biologist.

Many biological experiments are not reproducible. For example, in the study of single cells of the nervous system attention is focused on an element for a period of only minutes and then that element becomes nonfunctional. All measurements of the element must be made within a short span of time. Data analysis and processing must be done quickly, and decisions as to the course of the experiment formulated immediately, which requires rapid processing and presentation of results to the experimenter and completely precludes any data storage for later analysis. This is but one of many similar instances in biological research in which "instant results" are not only desirable but necessary. Such requirements are referred to as "on-line" or "real-time" requirements.

With a digital computer, experiments that necessitate manipulation of the time dimension are easily handled. Event time may be speeded up or slowed down. The com-

puter can reproduce in slow motion or stop action transient events too fast for visual comprehension, and it can reproduce in a fraction of a second that which took hours to transpire. Time events may be torn into little pieces, shuffled, rearranged, reassembled, and reproduced. This ability to rearrange and reassemble the time sequence of events is a unique capability of the computer, made possible by its memory; applications are limited only by the experimenter's ingenuity.

Our design of a data-processing system for biological research was dictated by requirements for on-line operation and for an instrument that could accept and process large quantities of data in a practical time. On-line operation requires control of the data processor from the laboratory, input of data from the experimental site in a form acceptable to the processor, and rapid communication of the results to the investigator.

## **Description of the system**

The on-line data processing system is built around a central processor, which is a Digital Equipment Corporation PDP-1, a medium-speed, medium-size digital computer. Conventional peripheral equipment includes a typewriter, a paper tape punch and reader, and a magnetic tape unit. Most pertinent to on-line operation are a remote-control console, a 16-inch cathode-ray-tube display unit, and an eight-bit analog-to-digital converter fed by a 14-channel multiplexer. A seven-bit, seven-channel, digital-to-analog output allows the system to appear completely analog in input-output characteristics.

## **Central processor**

The speed of the central processor is of major importance because many performance characteristics of the system in real-time operations are limited by this factor. The data input rate is constrained, not by analog-to-digital conversion, but by the speed with which the central processor accepts and stores samples. The complexity of the problem that may be computed in real time is directly dependent upon the speed with which logical operations are performed. The machine selected has a cycle time of 5  $\mu$ s and carries out arithmetic and logical operations in multiples of the memory cycle. Addition and subtraction are performed in 10  $\mu$ s; multiplication and division aver-

- ✓ *A significant segment of the future of digital computers would seem to lie in their use as scientific instruments. In one system, devised for a biological laboratory, the computer has joined the microscope and the oscilloscope as an integral part of the experiments*

age 25  $\mu$ s. These speeds give virtually instantaneous response to biological data, where times are measured in milliseconds.

Automatic transfer of data between the computer memory and the input-output equipment is another essential requirement for real-time problems. Such data channels do not go through the input-output register of the central processor and do not require elaborate control programs. A high-speed data channel added to the PDP-1 permits one data sample to enter the machine from the analog-to-digital converter each memory cycle, giving a maximum data acceptance of 200 000 samples per second. Additional automatic sampling speeds of 5000, 10 000, 25 000, 50 000, and 100 000 per second are also available. The central processor is free to carry on other operations simultaneously with the operation of the high-speed data channel. Automatic transfer of data between the memory and the magnetic tape, at a rate of 30 000 words per second, is also possible.

Certain limitations are imposed on overall system performance by the size of the random access memory of the central processor and the speed at which magnetic tape can be written. If data are accepted at a rate faster than they can be written on magnetic tape, the data sample is limited to the size of the high-speed memory. The PDP-1 has a basic core memory of 4096 eighteen-bit words, which can be expanded in units of 4096 as needed. Initial operations were begun with 4096 words but the memory was subsequently increased to 12 288 words, allowing the computer to store a reasonably large block of data while operating with a large and complex program. The 12 000-word memory gives a maximum sample length of 120 ms for signals sampled at a rate of 200 000 per second. As the sampling rate is reduced, the sample length increases proportionately.

The magnetic tape unit can write 30 000 eighteen-bit words per second. When operating in conjunction with the analog-to-digital converter, this rate becomes 50 000 nine-bit words per second for continuous operation (the nearest automatic conversion rate to the apparent 60 000 maximum). A signal sampled at 50 000 per second may run up to four minutes in length, and the sample length increases in proportion to this figure as the sampling rate is reduced. Thus, for sampling rates above 50 000 per second, the system can accept samples that are only milliseconds in length; for sampling rates slower than 50 000 per second, the maximum sample length becomes several minutes.

The PDP-1 has several very powerful programming features, such as program flags, indirect addressing, and

a sequence break mode, which, when coupled with an extensive repertory of arithmetic and logical machine operations, contribute greatly to the simplicity and ease of operating the system. Microprogramming within the input-output instruction list allows additional input-output equipment to be added and controlled quite easily. The PDP-1 also provides microprogramming within all nonmemory-reference instructions. This feature allows the machine to execute several instructions of this type simultaneously and facilitates real-time operation. Real-time processing does not lend itself well to programming with a translation program such as Fortran because data input-output is usually much more complex than arithmetic computation. All situations demand optimum use of time and each is a unique problem; therefore, the ease with which the machine can be programmed in machine language is of considerable importance.

Although the conventional typewriter, magnetic tape, and paper punch and reader serve vital functions, they are not new or unique to this system. Thus the emphasis of the present article is on those features that are essential to on-line operation.

### Interfaces

**Remote control console and visual display.** The remote console provides complete control of the data processing system from the laboratory site and is used in any laboratory in the building equipped with the necessary communication lines. It was designed and constructed by Systems Research Laboratories, Dayton, Ohio. With an executive routine in the central processor, the remote console permits selection of a program from a library stored on magnetic tape, control of any number of parameters in each program, examination of the current value of any parameter, and execution of the program upon command. These four basic modes of operation are activated by four push buttons located in the lower center of the console. In PROGRAM CALL operation the desired program is selected by the 12 push buttons on the right side of the console. The PARAMETER CHANGE mode permits changes to be made in whatever program is currently being executed. Parameters are changed by indicating the parameter number on push buttons on the left of the console and dialing in the desired numerical values (decimal) on the three rotary switches in the center of the console. Upon completion of a parameter change, the new value is displayed in the window just above the rotary switches. Type-out of program and parameter values provides a permanent record of all procedures. The PARAMETER DISPLAY mode permits display of the current value of any of the 20

parameters, selected by the push buttons on the left of the console. In the RUN mode the computer executes the program that has been set up by the operator.

Several interfaces between an experiment and the data analysis system are provided in the remote console. Provision is made for synchronization signals to be supplied to the experimental site by the central processor or for the program to be synchronized by a signal from the experiment. Data lines communicating with the multiplexer and the analog-to-digital and digital-to-analog converters are furnished.

The remote console also contains a special-purpose input device called an amplitude sampler, which bypasses the analog-to-digital converter and communicates directly with the central processor. The device makes peak magnitude measurements of an analog signal. When the signal exceeds an adjustable threshold value and falls back across this value without exceeding an adjustable upper limit (i.e., the peak occurs within a certain "window"), a gate is set. This gate, in turn, may be examined and reset directly by the central processor. The amplitude sampler has proved very useful in the analysis of neurophysiological data from single nerve cells in which the time of occurrence of a pulse is the important parameter.

A method of getting computed results out of the machine quickly, accurately, and in an easily understood form is an essential requirement for on-line operation. Visual display on a 16-inch cathode-ray tube is the preferred method for presentation of results in the laboratory situation. This display device plots on  $X$  and  $Y$  coordinates of  $1024 \times 1024$  points, and is capable of plotting 20 000 points per second. At this fast rate, functions plotted in sequence appear to be continuously changing in many instances. The overall speed of the converter-processor-visual display gives the appearance of an analog device, because data flow in and out with, in many cases, only an imperceptible pause. Results plotted on the visual display may be labeled and scaled according to need, and with the click of a shutter a finished print or slide is available for permanent graphic record.

**Analog-to-digital converter and multiplexer.** Since one of the most common and easily obtained forms of biological data is an analog voltage, the system must contain an analog-to-digital converter for changing these voltages into a language the computer understands. The converter chosen for this system is a Raytheon AD-50A, which has an aperture time of 50 ns and makes a conversion to eight binary bits in 200 ns. The very short aperture time approximates an instantaneous sample quite well. The converter is equipped with a bipolar unit that allows it to accept signals that are positive or negative with respect to ground. One of the eight bits indicates sign, and so final conversion of the signal is to seven bits plus a sign, giving the system a resolution of one part in  $\pm 128$ . This converter's capability of 5 million cannot be fully exploited, since data acquisition rate is limited by the central processor to 200 000 samples per second. However, the latter rate gives to the system an overall capability of dealing with signals up to 20 000 Hz. This bandpass of direct current to 20 000 Hz is more than adequate for most biological operations.

Ahead of the analog-to-digital converter is a 14-channel multiplexer, a Raytheon DM-120. With this device as many as 14 different data sources may flow into the machine simultaneously, though the channels are sampled

sequentially. The multiplexer's switching speed is one MHz, which exceeds the capability of the central processor. The 200 000-sample-per-second speed of the converter permits adequate sampling of a continuous flow of signals of frequencies up to 1400 Hz on each of 14 inputs. This upper cutoff frequency is raised as the number of channels in operation is reduced. Flexible selection of the sequence of sampling is controlled by a patchboard on the front of the multiplexer. The multiplexer may be expanded in units of 24 up to 576 channels, thus allowing for later expansion of the system as needed.

Analog voltage output, produced by a seven-channel digital-to-analog converter, covers a 10-volt range in seven bits and can generate one point every 15  $\mu$ s. The digital-to-analog converter was incorporated to give the computer system control over other analog instruments and to generate signals. The system can receive an analog signal, edit it, and regenerate it in analog form, which has proved very useful in obtaining selected short samples from a long run of data or for "rearranging" the time sequence of events in a sample.

The system is not limited to strictly on-line or real-time applications, but is equally capable of taking data from multichannel magnetic-tape recordings and editing or otherwise preparing the data for further analysis, which may be done either by the system or at the IBM 7094 computer facility at Wright-Patterson Air Force Base. The communication link between the computer facilities is digital magnetic tape. Compatibility of the magnetic tape unit with the IBM facility levies much more stringent requirements on performance of our unit, but it greatly expands the scope of the system. Data may be preprocessed on the PDP-1 for subsequent analysis at the larger facility and results of the computation read back at the PDP-1 for visual display.

As may be expected, use of the system has indicated that certain additional features would improve performance. Lack of a real-time clock has imposed an additional burden on the programmer, forcing him to generate a time base reference by program when needed. A multichannel sequence break system would make it possible to time-share the computer among several programs, and thus facilitate simultaneous off-line and on-line computer operation. A quasi-random large-capacity storage system such as a magnetic disk or drum would speed up retrieval of data in problems requiring large quantities of data to be processed. The lack of these features does not seriously restrict use of our system, but it does increase operation time.

With real-time operation, fingertip control of the processing performed on the data, flexibility and versatility of manipulation of data in digital form, and compatibility with the IBM 7094 computer facility, the system meets all of our design criteria. Several applications are outlined in the following to illustrate the type of problems in which the data-processing system is of assistance to the research worker in biology.

### Applications

The computer is an amorphous laboratory instrument with certain limitations and very broad capabilities, which may be utilized as the user desires. With adroit application of data processing and analytical techniques, it is possible to "create" a specific tool for the job at hand. We have found it expedient to have one individual with sole re-

sponsibility for writing real-time programs. It is not practical to teach each user the intricacies of real-time programming, but it is essential he understand the capabilities of the computer system if he is to make proper application to his specific problems. The skill of the real-time programmer is a vital key to successful operation. Development of a specific program becomes a joint endeavor of the experimental scientist, who states the nature of the instrument he wishes to create, and the computer programming specialist, who adapts these specifications to the system at his disposal.

The full capabilities of the system as a laboratory tool are still unknown. They are restricted at present by our ingenuity and by our research problems. The applications given here should be regarded as illustrative of general classes of capabilities and not treated as specifics.

**On-line average response computing.** Average response computing is useful in biological research for two reasons. First, in describing performance of a biological system, which may be quite variable, it is often advantageous to give the description as an average. Second, the technique is useful in extracting signals that are buried in noise if the response is time-locked while the noise varies randomly. Figure 1 illustrates the technique as applied to the measurement of the electrical activity of the brain in response to a light flashed in the eyes. The sequence of waveshapes illustrates how the shape of the function becomes more consistent as the number of samples increases. We may conclude that the function shown in the last example is the ensemble average electrical activity occurring at the recording point in response to the light flash.

**Neuron statistics.** One of the more extensive applications of the data processing system has been analysis of neurophysiological data. Output of single elements (neurons) of the nervous system takes the form of a time sequence of pulses. Many statistical analyses are made of these data. Multiple measures are taken simultaneously, in real time, as the data are collected; the statistics are updated with each new sample and a visual display is presented.

Note the identification at the top of the visual display shown in Fig. 2, which is added to preclude the possibility of confusing the data samples. Below identification are three presentations of statistical measures of the pulse data. The data processing system computes and displays all of these statistical measures while recording and storing data in the special format. At the same time, by means of the digital-to-analog converter, the central processor is generating a modulation voltage for the sound signal being given to the test subject.

The topmost of the three presentations is a pulse-density histogram, which shows total number of pulse occurrences at each sampling interval for the entire ensemble of responses. The middle presentation shows the average position of each pulse in relation to the signal, computed over the ensemble. Location of each line is the average position of that pulse and the length of the line represents the total number of times each particular pulse occurred in the ensemble. The bottom presentation is a histogram plot of the distribution of intervals in the entire ensemble.

The system controls the stimulus to the subject and records and processes the response of the nerve cell to that stimulus. Control of the test signal and of the data

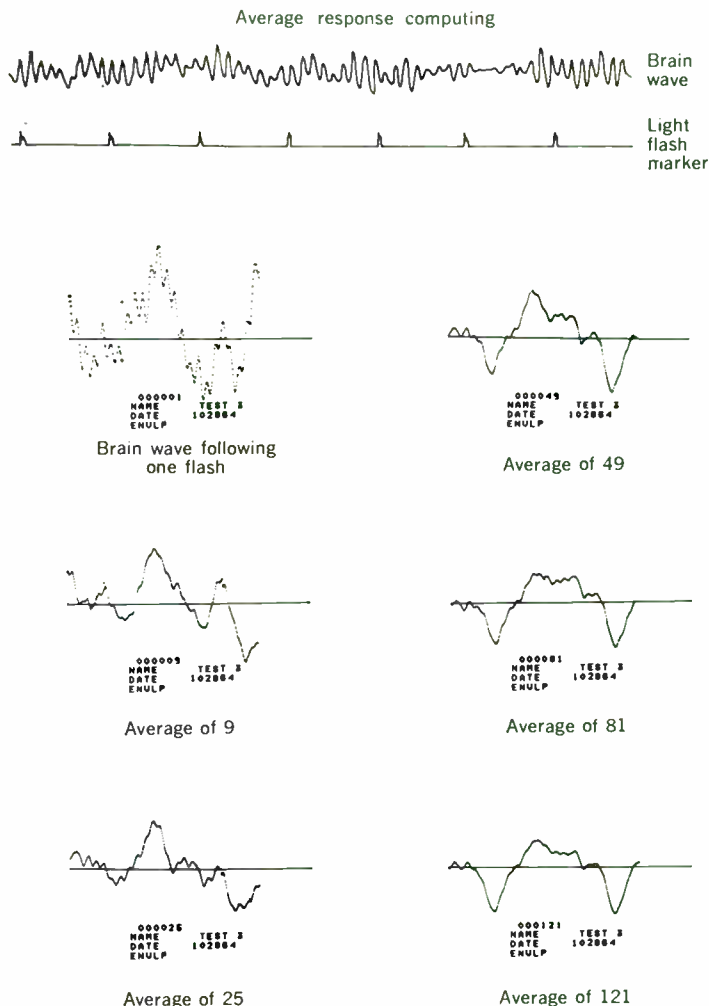
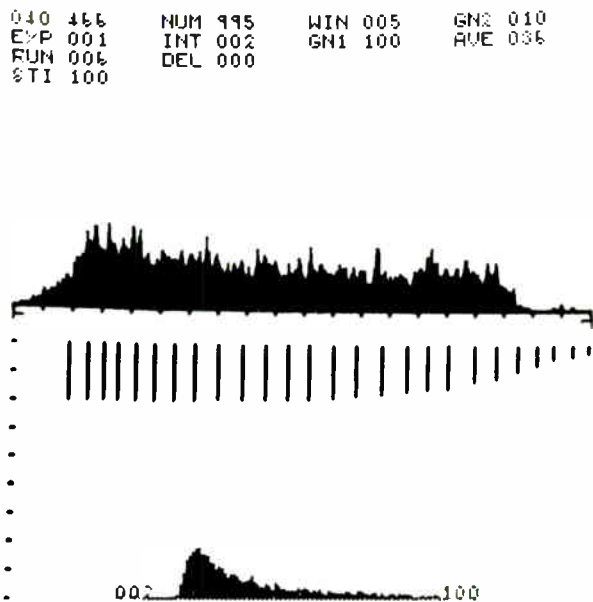

Fig. 1. Average response computation.

Fig. 2. Visual display of results of three statistical measures applied to biological data from individual nerve cells simultaneously and in real time.



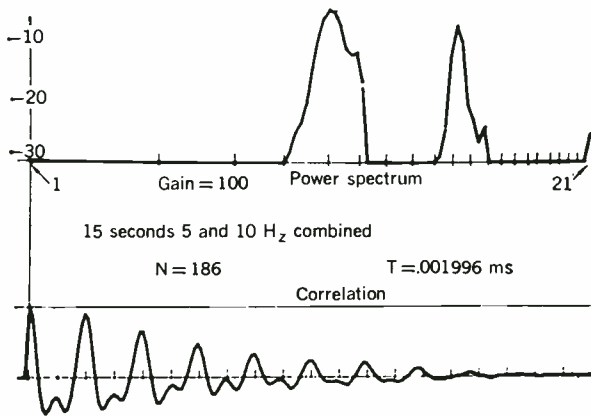
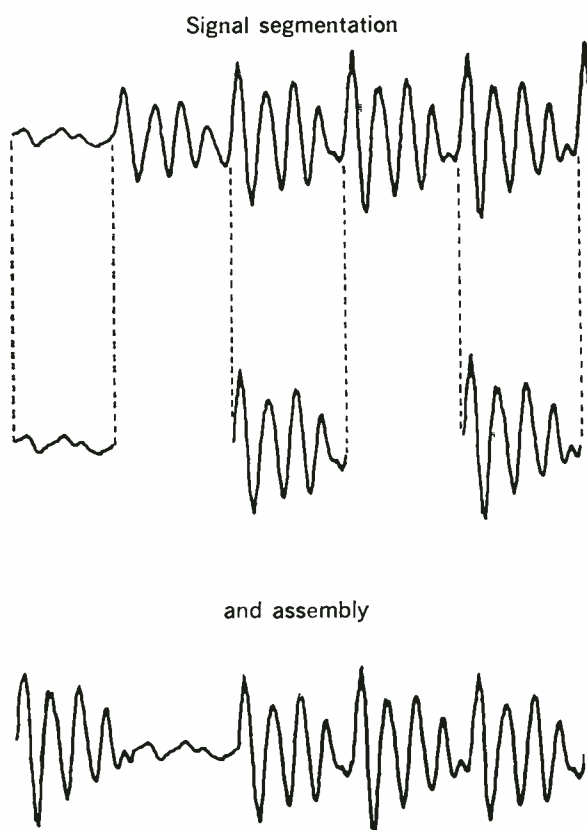

Fig. 3. Real-time correlation and power spectrum analysis.

Fig. 4. Dissection and reconstruction of a signal.



processing program are at the fingertips of the experimenter through the remote control console. Other programs are available for computing higher-order statistical measures. Based upon the results of the nerve cells' response displayed before him, the experimenter specifies the next type of test signal to be given to the neuron. Because of the very labile nature of nerve cells in this type of situation, the entire experiment would be impossible without on-line data processing.

**Real-time autocorrelation.** Autocorrelation of an analog signal is computed as the data enter the system. Upon termination of the sample or upon reaching overflow values, the power spectrum of the signal is computed from the autocorrelation function and both functions are

visually displayed four seconds later (Fig. 3). The program is currently being utilized in analysis of the electrical activity of the brain.

**Slow-motion rewrite.** Multiple-channel analog signals are sampled in real time with the multiplexer and analog-to-digital converter; see Fig. 4. The data are then replayed in slow motion or stop motion, with the analog signals being presented as visual displays. Visual analysis of the fast-moving details of the waveforms is thus made possible; comparisons can be made across channels. The data are selected and edited before further analysis is performed.

**Computalk.** A good illustration of the ability of the computer system to manipulate the dimension of time is provided by a program developed for research on speech. In this experiment an electrical waveform from a microphone is sampled at 25 000 samples per second. A stored signal, 350 ms in length, is then reproduced graphically on visual display and the operator selects a particular segment of the waveform—perhaps 1 to 10 ms in length—by pointing to it with a light pen. A typewriter code identifies the selected segment and it is stored (up to 25 coded segments can be retained in machine memory). The typewriter control permits reassembly of the waveforms; reiteration of a single segment produces a sustained output. The waveform is regenerated electrically by the digital-to-analog converter and the sound reproduced from a loudspeaker. Samples may be reassembled in any order and reiterated for any period of time regardless of the sequence in which they were collected. Microdissection of a waveform with complete flexibility of reassembly can only be achieved with an instrument such as the digital data processing system for biological research.

**As an analog model.** In one instance the digital computer became an integral operational block in an analog system. A model of the functional properties of a nerve cell was partially realized with analog circuitry while another portion of the model, difficult to achieve with analog methods, was generated by the digital computer. It is significant that the entire computer system is so simple to operate and control that we chose to use it as a building block in a small analog model because it was the easiest and most expedient solution.

## Conclusions

It has been the thesis of this article that digital computers have unique and unexplored capabilities as laboratory instruments. A digital computer in conjunction with an assortment of peripheral equipment forms a system with many abilities useful to the laboratory scientist, but control of the system from the laboratory and visual display output are essential to ease of operation. The speed of equipment available today permits the digital system to operate in real time with many analog characteristics.

The most outstanding and unique features of the analysis system discussed are its flexibility and memory. Exploitation of these capabilities has just begun; however, researchers with backgrounds in medicine, biology, physiology, psychology, mathematics, biophysics, electronics, and engineering already have successfully employed the system to aid them in their work.

This article is based on AMRL Technical Report AMRL TR-66-74. Further reproduction is authorized to satisfy the needs of the U.S. government.