

The ROMANCE *and* REALITY of TELEVISION

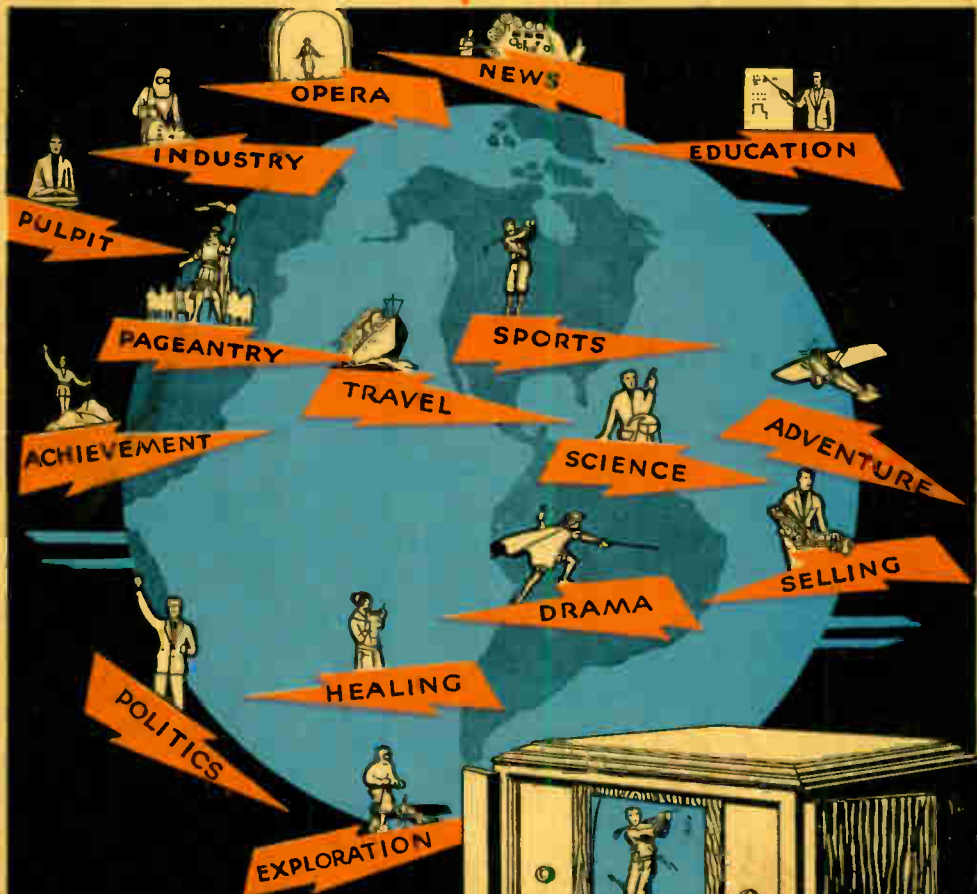

SHORTWAVE *and* TELEVISION
LABORATORY Inc.

WIXAV
BOSTON U.S.A.

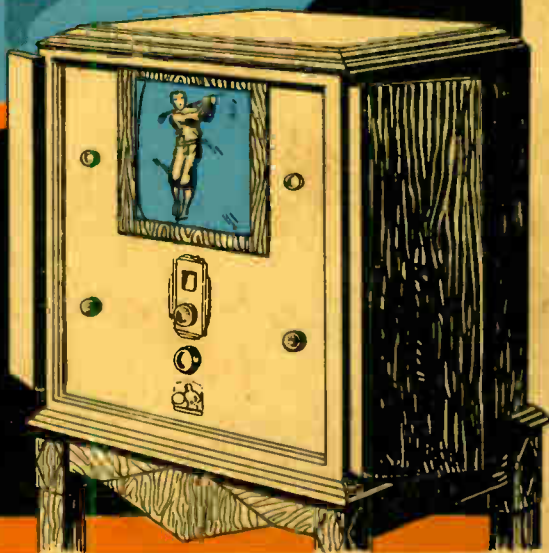

The
ROMANCE AND REALITY
OF TELEVISION

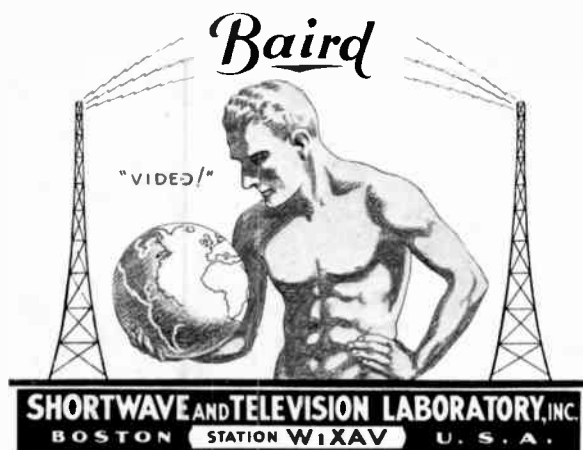

TRADE MARK

Copyright 1930 by Shortwave & Television Laboratory Inc.

70 BROOKLINE AVENUE
BOSTON, MASS.



The Baird Universal Television Receiver.
Patents Applied For

THE ROMANCE AND REALITY OF TELEVISION

Men my brothers, men the workers,
Ever reaping something new;
That which they have done but earnest
Of the things that they shall do.

. . . .

For I lift into the future
Far as human eye could see;
Saw the vision of the world
And all the wonders that would be.

Tennyson.

THE romance of Television has gripped the minds of people in every part of the world as no other modern invention has done. It is a curious fact that the public accepted this eighth wonder before it was out of its swaddling clothes. Every modern invention has always met with adverse criticism and scepticism, but so much advance publicity (often exaggerated) has been given to Television that the preponderance of feeling has been that it has definitely arrived.

This was only partially true until quite recently, when a really practical Television receiver was developed after years of extensive and concentrated effort on the part of Mr. Hollis Semple Baird, B.Sc., Chief Engineer of the Shortwave & Television Laboratory, Inc., of Boston. For years before this development commercial Television was a dream, truly a marvelous one with far reaching effect, but seemingly impossible of attainment.



Home of the Shortwave & Television Laboratory, Inc., and Station WIXAV at 70 Brookline Avenue, Boston.

ROMANCE AND REALITY OF TELEVISION

The various laboratories of the General Electric Company, the Radio Corporation of America, the Bell Telephone Company and others had successfully televised subjects with remarkable fidelity but the equipment necessary for the production of such results was not only elaborate, but tremendously costly and absolutely beyond the possibility of reproduction anywhere but in the laboratory.

It was the ingenious brain of Mr. Baird that developed a simple Television receiver that is only about 15 inches square and that reproduces a transmitted Television image with even greater detail than any elaborate laboratory equipment has ever been able to attain. The goal—a commercial Television receiver—has been reached, and the Shortwave and Television Laboratory, Inc., are in production on such a receiver. This receiver, which is housed in a beautiful console cabinet, will be an added feature to any home. It has been our intention to make this unit as inconspicuous as possible, to take up very little extra space in the home and yet be a source of untold pleasure.

The Television receiver which will be set up in your home has a world of human interest in back of it. If it were possible for the reader to visualize the months and months of nerve racking effort, the disappointments, the temporary successes, the days of plugging assiduously at a herculean task, sometimes working through from one day into another without pause for sleep; building up and tearing down, until at last success, in all its pleasure and relief, was attained, he might have some conception of the mystery and wonder of this new pleasure for the home—TELEVISION.

BUTLER F. PERRY
Treasurer



A. M. MORGAN
President and General Manager



HOLLIS S. BAIRD, B.Sc.
Chief Engineer

Officers of the Shortwave & Television Laboratory, Inc.

WHAT IS TELEVISION?

LITERALLY *Television* means vision at a distance. The word is composite, being derived from a mixture of Greek and Latin: *Tele* "at a distance" and the verb *Video* "I see."

Like everything else of a revolutionary character, Television did not come to us over night. It was nearly 60 years ago that an operator named May, while working in the Atlantic cable receiving station in the village of Valentia on the West Coast of Ireland, noticed that his instruments were acting in a peculiar manner. It appears that at that time Selenium was being used purely as a high resistance to electricity and by accident May discovered the fact that as the sun shone occasionally through the window onto this Selenium, the needle on the instrument moved and it was just this that gave scientists their first progressive step to the photo-cell, or electric eye.

As far back as 1884 a Russian inventor named Nipkow conceived the idea of Television and it was on that date that he first used the idea of a disc with small holes in it to break up a scene to get the different light variations. It was impossible for him to go very far, as he had neither the proper photo-cells nor the proper method of amplification, but the idea which he formulated has been the basic principle of Television.

It may be well to quote here from "*Television*" by Alfred Dinsdale, A.M.I.R.E., member R.S.G.B., which is particularly lucid in its explanation of this "Television eye."

"Scientists were quick to predict that Selenium would provide an electric eye to supplement the electric ear which the



Reception Room, Facing the Broadcast Studio.

ROMANCE AND REALITY OF TELEVISION

then recently-invented telephone had given to them. . . . There was, however, a serious difficulty to overcome, and over 50 years elapsed before the solution was found. This was the difficulty: that whereas the natural eye sees a whole scene in one comprehensive glance, it was not possible for the selenium cell to achieve the same result.

"Perhaps the simplest way to make the matter clear is to consider that very perfect Television apparatus, the human eye, with its connecting nervous system. The eye itself may be compared to a camera. It has a lens and a screen, the lens throwing an image of the scene before the eye upon the screen. This image has to be conveyed to the brain, and Nature's method of solving her Television problems has formed the basis of many of the first Television schemes. A clue to the solution of the problem is found in a close examination of the human screen, which is called the retina. The surface of this is found to consist of a mosaic made up of an enormous number of hexagonal cells, and each of these cells is directly connected to the brain by a number of nerve filaments along which travel impulses which are dependent upon the intensity of the light falling on the hexagonal cell. Exactly how these impulses are generated is not at present fully understood, but they are almost certainly due to the presence of a light-sensitive substance, named "visual purple", which flows through the hexagonal cells. The images which we see are thus built up of an extremely fine mosaic of microscopic hexagons of varying degree of light and shade. The number of these hexagonal cells is stupendous—a normal human eye containing several millions.

"The early experimentors endeavored to construct artificial eyes by substituting selenium for visual purple and building an



General Offices of the Shortwave and Television Laboratory, Inc.

ROMANCE AND REALITY OF TELEVISION

artificial retina out of a mosaic of selenium cells, each of these cells being connected by wires to a shutter. This shutter opened when light fell on the cell connected with it, and allowed a spot of light to fall on a screen. In this way each cell controlled a spot of light, the image being reproduced by a mosaic formed of these spots.

"Models on these lines were actually made by several inventors. Rignoux and Fournier, two French scientists, constructed a machine on this basis in 1906. This apparatus was intended to simply demonstrate the principle, and had no pretensions towards being an instrument for Television. The transmitter consisted of a wall covered with selenium cells, 64 fairly large cells being used. From each of these cells two wires ran to the receiving screen, which was made up of 64 shutters, each shutter controlled from its respective cell, and thus when a strong current from a brilliantly lighted cell at the transmitter arrived at the receiving station the shutter was opened and light was allowed to fall on the corresponding part of the receiving screen. By covering the transmitting wall with large stencils, letters of the alphabet were transmitted and could be recognized.

"Ernst Rhumer, whose brilliant work in connection with wireless telephony is so well known, also constructed a similar apparatus, and many other workers have been attracted by this system; but the thousands of cells, shutters and wires necessary made the practical adaptation of such schemes out of the question, and an endeavor was made to solve the problem in quite a different manner.

"The suggested alternative was to divide the scene up into a great number of small parts and to transmit it section by sec-

ROMANCE AND REALITY OF TELEVISION

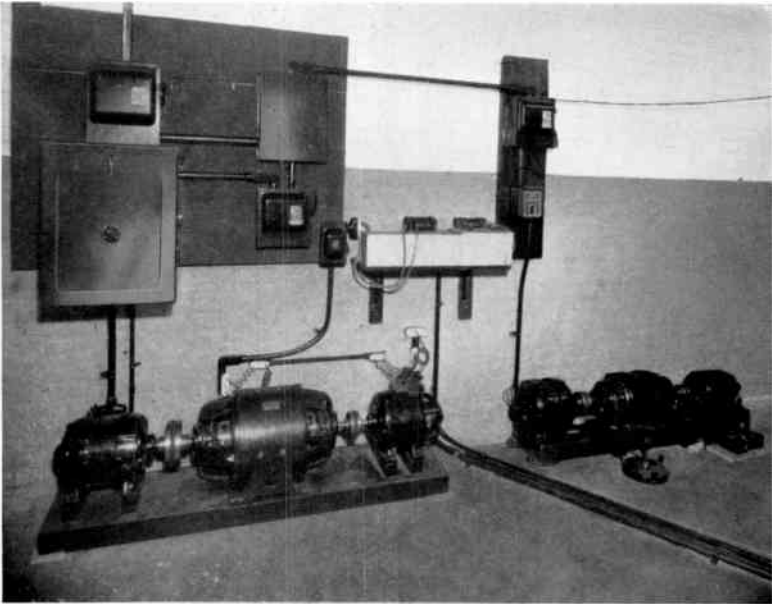

The Generators which supply the power for Shortwave and Television Broadcasts.

tion to the receiving end, and to achieve this so rapidly as to create the effect of an instantaneous glance.

“Imagine, for example, that by means of a lens an image of the object or scene to be transmitted is thrown on a ground glass screen just as in a camera; imagine then this image divided up into thousands of little squares like a chessboard; each one of these little squares is dark or light, depending on what part of the picture it belongs to.

“Now we have to send this picture along a wire or over the wireless. Assume there are one thousand squares numbered from one to one thousand; then if we send a series of messages: 1 dark, 2 light, 3 light, 4 dark, etc., to our friend at the receiver, who has a board before him divided also into 1,000

ROMANCE AND REALITY OF TELEVISION

squares, and he makes his squares dark or light as directed, he will build up the mosaic similar to the mosaic on our ground glass camera screen. Now, in this operation we looked at each little square and our eye told us whether it was dark or light.

"If we passed a light sensitive cell over the square it would send out an electric signal which would be weak or strong corresponding to the light or shade of the image, and if, instead of a friend, we had a mechanical device directing a beam of light from a lamp on each square of the receiving board in turn, at the same speed as the cell at the transmitting station passed over the corresponding square on the ground glass screen; and if, further, the intensity of the light was controlled by the current from the cell, then each area of the board at the receiver would in turn be illuminated with a brightness corresponding to the brightness of the same square on the transmitting screen. If this progress is gone through eight times every second, then the observer would see on the receiving board not a moving light spot of varying intensity but the whole image at once, due to the phenomenon of retentivity of vision. This is roughly what happens in Television."

Now let us explain how Television pictures are transmitted. The studio is in semi-darkness except for one lighting source, consisting of a powerful arc light with two carbons; the points of the carbons are kept quite close together, and a large current flows across the points and produces an arc of intense brilliance,—32,000 candle power. This is the light used to transmit the picture. Just back of the arc is a parabolic mirror that catches the light rays and sends them forward by a powerful beam. The beam is directed toward an endless belt 15 inches in diameter, called the scanning belt which is supported

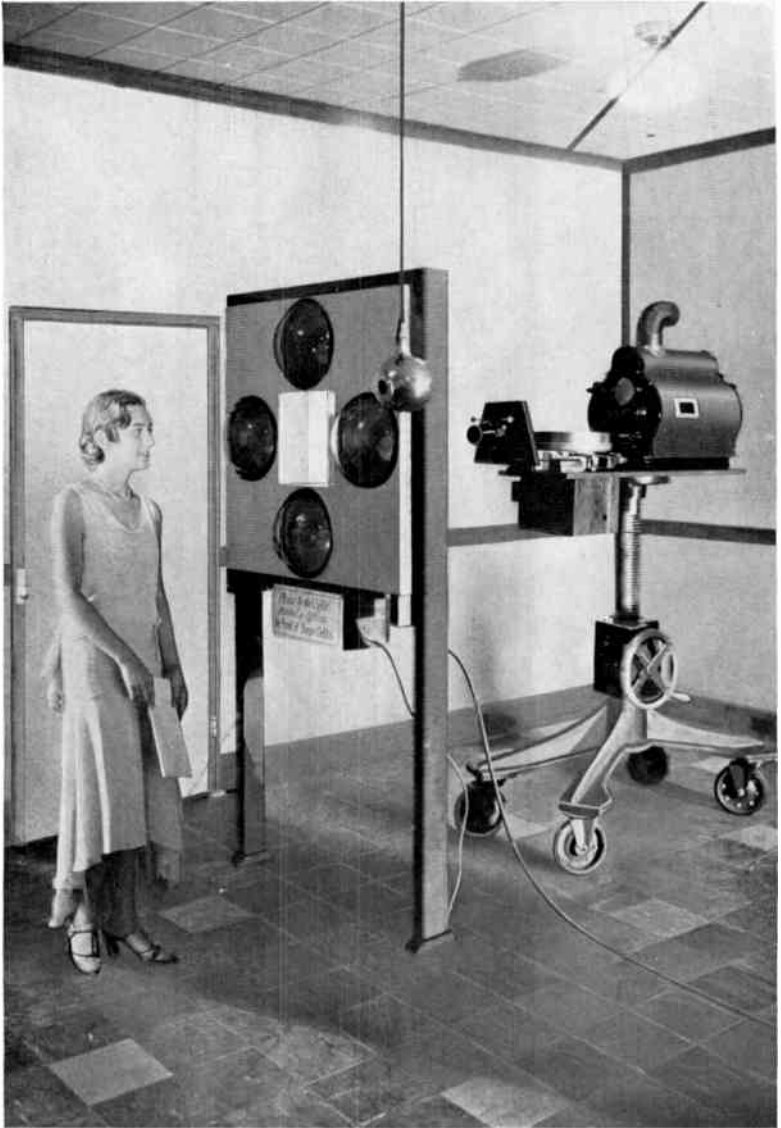

The Television Scanning Apparatus, while a subject is being taken, showing the illuminating arc, the scanning equipment, and the Photo Cells. The Condenser Microphone is seen suspended from the ceiling.

ROMANCE AND REALITY OF TELEVISION

on a metal spider. Around the edge of this belt there are 48 square holes equally spaced and arranged in a spiral, the first hole starting close to the top edge of the belt and the last hole placed the farthest away. The scanning belt is turned rapidly in a horizontal direction by an electric motor called a synchronous motor, operating on a 60 cycle alternating current. As the scanning belt rotates the beam of light strikes one hole at a time and passes through the hole like a tiny window. There are 48 tiny windows and every time the belt makes a complete revolution each window in turn is brought in line with a beam of light and the light passes through. After passing through the holes in the scanning belt the light beams next pass through projection lenses similar to those used in moving picture machines. These lenses focus the light beams in spots on the object to be televised. As the young lady in the picture (*page 14*), stands in front of the television apparatus, her face is being scanned by 2304 spots of light every twentieth of a second, 46,080 spots every second. The rotating belt simply illuminates the object with these separate spots of light. The picture is really sent to you piecemeal, in all 2,304 separate points of light. In your receiver these points of light must be put together to form the complete picture.

And now let us explain about the strange eyes here that view the object piece by piece and transmit it to you: the photo-electric cell. There are four of these photo-electric cells spaced in a square frame to take in every detail of the subject. Each cell is 12 inches in diameter and looks like a big fish bowl from the front. It is really a spherical globe with all the air pumped out and with a little argon added. Argon is an inactive gas present in the atmosphere in small quantities. The front of each cell, called the window, is transparent, so that reflected

ROMANCE AND REALITY OF TELEVISION

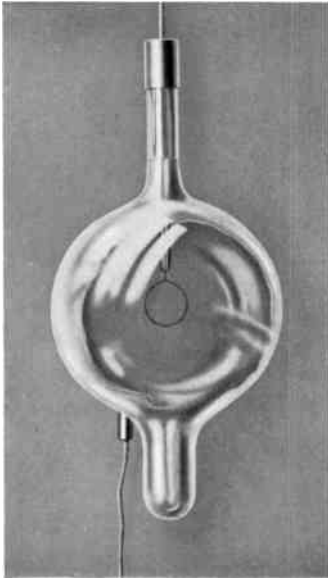

A 12" diameter photocell used in our studio. One of the largest ever made for Television.

light can shine through to the inside. The rear half of the inside surface is coated with a metal called potassium, an alkali metal like sodium or calcium. One peculiarity about this wonderful metal is the fact that light affects it and causes it to throw off tiny particles of electricity called electrons. Two wires lead out of each photoelectric cell; one wire connects with the coating of metallic potassium, the other wire is connected to a piece of nickel placed at the center. The cell is extremely sensitive to light. The slightest variation in light

will release a greater or less number of electrons from the metal surface. More light releases more electrons; less light releases fewer electrons. These electrons jump across the space inside the cell to the metal ring because it is kept positive.

The photo-electric cell "views" the object and creates a pulsating current which transmits it to you. A complete picture is sent every twentieth of a second, and for every picture over two thousand spots of light are sent, scanning it completely from side to side, and from top to bottom. One can readily understand that a single spot of light will cover only a small area of the object scanned. Each spot of light is then reflected or bounces back like a rubber ball. Light reflection depends upon the surface of the object it strikes, the color, smoothness,

ROMANCE AND REALITY OF TELEVISION

etc. A light colored object reflects more light than a dark colored one. Furthermore, a smooth surface, like a mirror, reflects more light than a rough surface, such as blotting paper. So that each light spot that strikes the subject is reflected with greater or less intensity according to the color and surface. For example, hair, eyebrows, and lips, being dark, reflect less light than parts of the cheek or nose. It is this variation of light reflection that makes possible the transmitting of the complete picture.

As each spot of light strikes the object, the reflected rays of greater or less intensity pass into the photo-electric cells, striking the metallic potassium and releasing electrons according to the light variation. Stronger light rays release more electrons, while weaker rays of reflected light release fewer electrons. Thus we have for every complete picture over 2,300 light variations, one from every spot reflected from the object. Every light variation varies the number of electrons released from the potassium of the cell which gives a constantly varying current flowing out of the cell, in fact, 40,000 variations every second. Now this current is extremely weak at first, and must be increased in strength or amplified immediately. This is done by vacuum tubes, similar to those in your radio set. The amplified current from the cells then goes to the modulator. This is a six stage amplifier which has a power gain of over 450,000,000,000 times. A master oscillator is generating a carrier wave, in our case, of 141 meters or 2,120,000 cycles. This is the steady wave that gives you the whistle when you tune in on a station. The carrier wave is amplified and the output goes to a 50-watt tube, where the picture signal modulates it, making peaks at varying heights. The modulated wave is then amplified by two 1,000 kilowatt tubes.



The Baird Television Receiver as it is Installed in the Home.

AND NOW — TELEVISION IN THE HOME

We have explained in detail how these pictures are put on the air. Now we come to the Television receiver—the outfit you may have in your home to view these pictures. A simple Television receiver, only about fifteen inches square, has now been developed for home use. The entire equipment is enclosed in a console cabinet about the size of the ordinary radio console. The operation is so easy that a child can tune it in, and the cost is no more than you would have to pay for a good radio receiver of the ordinary type.

There are in reality two units enclosed in the same console, a shortwave receiver and the Television unit for viewing the picture. The shortwave receiver which picks up the Television signal is located in the same cabinet with the Baird Television unit and the A. C. power pack, which also actuates the Neon lamp. The shortwave receiver has two stages of tuned screen grid radio frequency, a non-regenerative screen grid detector and three stages of resistance coupled audio amplification feeding into the 245 power stage. Resistance coupling is necessary owing to the fact that a Television picture contains frequencies from 10 cycles up to as high as 40,000 cycles and ordinary transformer or impedance coupling cuts off frequencies above 8,000 cycles.

On the front of the cabinet appears a lens approximately 6 inches square and below this is the tuning dial the same as in the average radio set in the home; a switch to turn your

ROMANCE AND REALITY OF TELEVISION

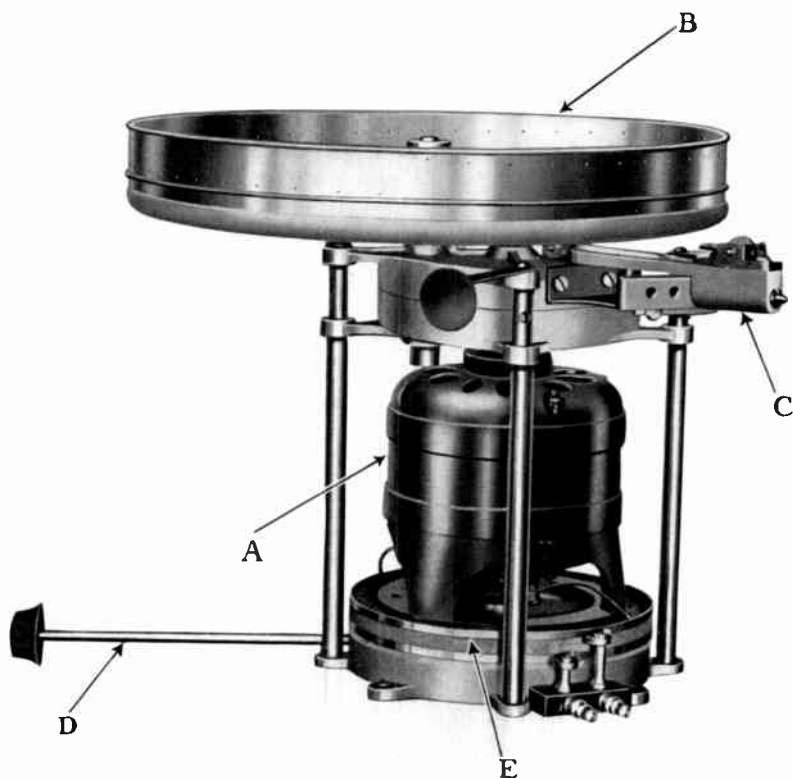

Chassis of the Baird Television Receiver (the Neon Lamp is not shown, as it is attached to the lid of the Cabinet).

Patents Applied For

EXPLANATORY DATA FOR TELEVISION CHASSIS

- A—1/15 h.p. synchronous motor.
- B—Removable film or belt for interchanging to 48 or 60 lines.
- C—Adjusting lever for gear box to change speeds from 15 pictures to 24 pictures a second.
- D—Framing device for keeping picture in frame; it is possible to frame continuously in one direction or the other without having to turn back.
- E—A.C. sliding contacts to allow framer to turn continuously in one direction which simplifies the possibility of keeping televised picture in frame when not on same synchronised line.

ROMANCE AND REALITY OF TELEVISION

current off and on and a volume control for increasing and decreasing the quality of the picture. The receiver therefore is absolutely silent and after throwing the switch you simply tune the dial until a picture appears through the lens. Then comes the Television unit that actually receives the picture. This consists of a small synchronous motor that turns a horizontal metal plate called a "spider", which supports a narrow strip of thin steel perforated with square holes, a Neon lamp and a lens.

The power necessary to revolve this spider at the proper speed is naturally considerably less than that used for a two-foot scanning disc which has terrific centrifugal force, so that where it was always necessary to use a synchronous motor of $1/3$ to $1/2$ H.P., we now need one of no greater power than $1/15$ H.P. The synchronous motor which is used in the Baird Television unit has only been perfected in very recent years and is the only type of motor which maintains a constant speed. The electric wave which carries a Television picture must be re-assembled on the scanning device at the receiving end in the exact manner that the picture was analyzed at the transmitter. This means that both the transmitting and receiving equipment must run at the same speed, and any number of synchronous motors on the same A. C. power system will run at the same speed. Voltage changes and small load changes will not affect this speed as they will an induction motor. If the frequency of the A. C. line varies, the speed will vary over the entire system, so that the motors will still be in step. Power networks are covering such large areas today that very shortly the whole Eastern part of the country will be one large synchronous A. C. network.

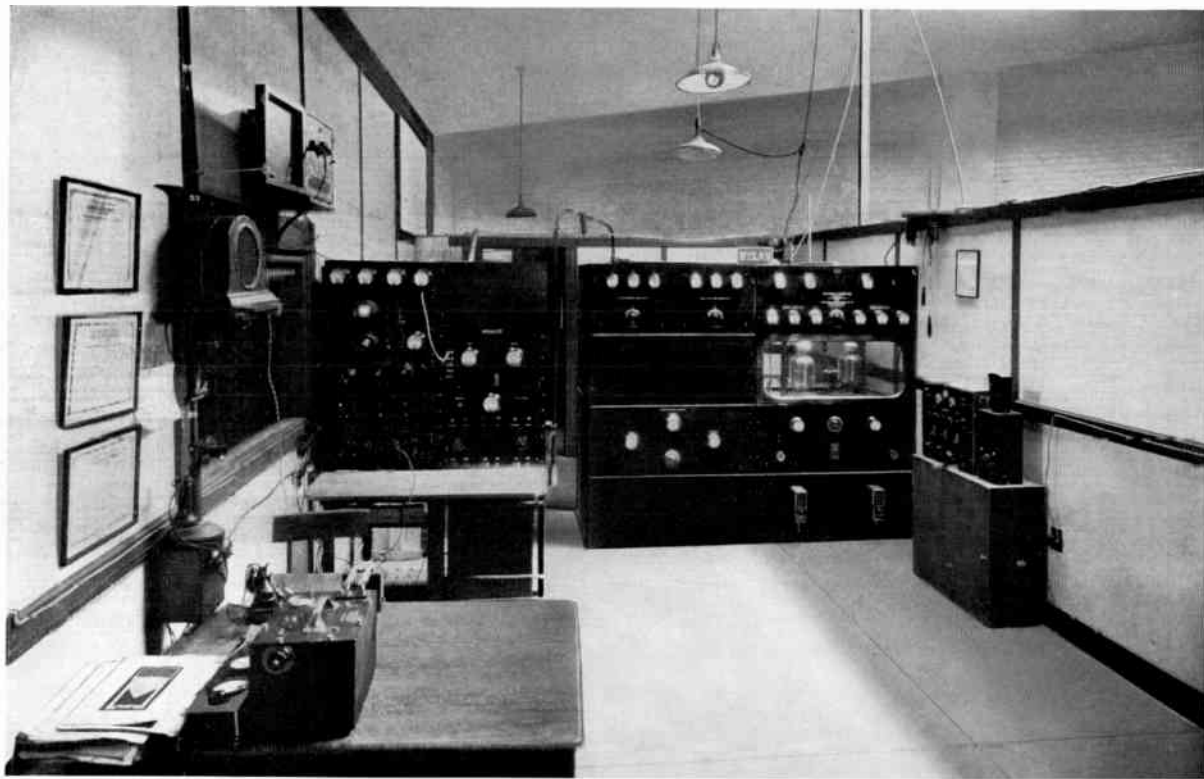

Television Transmitter and Control Room.

ROMANCE AND REALITY OF TELEVISION

The picture actually appears on the plate of the Neon lamp. It corresponds to the loud speaker on an ordinary receiving set. This lamp is a sealed glass tube containing a rarified atmosphere of neon, a chemically inert gas prevalent in small quantities in the earth's atmosphere. The tube contains a square nickel plate and wire grid separated by a distance of a fraction of an inch and connected with wires leading out through the base. The plate is kept negative and the square, wire grid positive. When a high voltage current is maintained between the grid and the plate, the plate glows with an orange-red light. You doubtless have seen plenty of these neon signs, which glow with different colored lights at night. These signs consist of glass tubes filled with the same gas, neon. A current at high voltage is passed through the gas which breaks it up into charged particles, atoms, and electrons. The constant collision or bombardment of these particles produces the light you see. It is really a constant lightning flash on a miniature scale.

And so it is with the neon tube used in Television. The high voltage maintained causes the plate to glow so that it seems to be covered with a thin filament of red light. Any change in voltage applied to this tube will change the brilliancy of the light. If more current flows into the tube, the plate glows with increased brilliancy. If less current flows into the tube the brightness of the glowing plate is lessened. This change of voltage is produced by the signal received and amplified by the shortwave receiver. The signal transmitted from the broadcasting station is by means of the photo-electric cells. As we said before, the complete picture is sent out in 2,304 separate parts. 2,304 spots of light strike the subject every twentieth of a second, and according to the reflected

ROMANCE AND REALITY OF TELEVISION

power of the small area struck at any instant, weaker or stronger rays are reflected into the photo-electric cells here, releasing electrons from the potassium coating. The brighter the light striking the potassium, the more electrons are released. Hence, a current (that is, a flow of electrons) passes out of the cell, with a greater or lesser intensity, that varies over 2,000 times in 1/20th of a second. These current variations are used to construct the transmitted waves, and when you pick up these waves, the same variations of current are impressed on the Neon tube in your receiving set, with the same variation of over 2,000 times and 1/20th of a second, and reproduces the same number of changes in the light emitted from the illuminated plate of the tube.

And now we come to the description of how the picture is really put together so that you see it in its entirety. The horizontal spider or frame is rotated rapidly in front of the neon lamp by means of a small synchronous motor, because the spider must rotate at exactly the same speed as the scanning disc at the transmitting station. Around the edge of the spider is a circular strip of thin steel with 48 square holes punched through it. The holes are one twenty thousandth of an inch in width, spaced equally in the form of a spiral. This steel strip is made into an endless belt rigidly supported on the spider and rotated by the motor. It is of extreme importance that one realizes that the use of both horizontal scanning and receiving has NEVER before been accomplished and yet this is the ideal method of transmitting and receiving a picture due to the absolute elimination of distortion. This cannot be overcome by the vertical method as in revolving, the disc must cause a slightly curved line due to the radial placement of the scanning holes.

ROMANCE AND REALITY OF TELEVISION

As the metal strip revolves, the neon lamp which is placed within the spider and directly in back of the perforated metal strip, throws an individual spot of light through each hole in succession. Because each hole is dropped its own diameter below the location of the preceding one and because the spider carrying the metal strip revolves at high speed, we naturally get the illusion of 48 lines of light travelling downward in rapid succession. Each spot of light is there on the plate of the tube for only one forty thousandth of a second. Due to the retentivity of vision, that is, the fact that the image of an object is retained by the eye for some time, the whole 2,304 points of light are retained on the retina of the eye, the result being a complete picture, and since this happens twenty times a second the eye is unable to distinguish the individual pictures and sees them in motion, a moving picture of the object.

The neon lamp actually reproduces 40,000 light variations per second, the number transmitted, and puts these variations together reassembling them into twenty complete pictures per second giving you a realistic moving picture of the object scanned there in the studio. The received image on the plate of the neon tube is only about one inch square. This is magnified by a lens to four inches square, making it possible for as many as five or six people to view the picture at the same time.

The simplicity of tuning the picture in and out is remarkable. There is no more difficulty than there is in tuning in the voice on your regular radio receiver for a local station. In some sections of the country large areas are already synchronized with the result that there is no trouble in keeping the picture in frame. By that we mean that it is possible for a picture to be split up when first received so that the picture will not be in the exact center of the receiving apparatus which con-

ROMANCE AND REALITY OF TELEVISION

dition can be compared to the adjustment of a moving picture machine.

There is an ingenious method of bringing this picture into frame in a particularly simple manner. A small knob projects from the front of the cabinet and by turning this knob either to right or to left it will gradually bring the picture into the proper position. The operation is no more difficult than turning the volume control knob on a radio set which makes your reception either louder or softer. This same framing device is employed in tuning where the Television picture is received from a transmitting station that is not on the same synchronized line as the receiver. This lack of synchronism will have a tendency to make the picture move out of frame but by slowly turning the framing knob the televised picture can be kept in continual view.

It is well to explain here that there is no fixed standard for the transmission of Television signals. *The dozen or more stations which are today transmitting Television images are using various combinations, such as a 48 line picture with 15 pictures per second, or a 60 line picture with 24 pictures per second. The fact that the Baird Universal Television unit is so constructed that it will take ANY AND ALL OF THESE SPEEDS makes it efficient to the point where it will get any Television signal on the air. This is an extremely important factor; were it not so designed, the receiver would only be capable of getting one station and no others.*

The method of changing the speeds and lines is extremely simple. The 48 hole steel belt is supported on the spider in such a way that it can easily be removed and a 60 hole belt put in its place. There is an adjusting lever protruding from

ROMANCE AND REALITY OF TELEVISION

the chassis, which when moved one way gives you a synchronous speed of 900 r.p.m. and when moved the other way increases it to 1,440 r.p.m. This adjustment can be made in a matter of a few seconds. To prevent any damage to the Receiver, the action of raising the lid of the console to make the change automatically stops the machine.

The installation of the Baird Universal Television Receiver simply necessitates an electric light outlet and an aerial or a connection to the present aerial which you may have for your radio set. The Television receiver can work from the same aerial that you are now using and at the same time without interfering with your regular radio program.

The engineers of the Shortwave & Television Laboratory, Inc., have been devoting their energies entirely to the transmission of subjects in *halfstone** through its 500 watt Station W1XAV. They are now preparing to install apparatus for the Television transmission of special subjects by talking movies. These will all be in *halfstone* and should not be confused with the transmission of *silhouettes*.*

* "**Halfstone**" transmissions show the subject photographically; i. e., with all tones of light and shade faithfully reproduced, as in a portrait photograph.

"**Silhouettes**" merely transmit solid shapes, without any detail of light and shade.

ROMANCE AND REALITY OF TELEVISION



Reproduced from the Boston Evening American of Thursday, February 6, 1930

The world's first simultaneous transmission of sound and living image was made in Boston last night in the studios of the Shortwave and Television Laboratory, 70 Brookline ave. The sound waves were transmitted by WEEI, and the television by Station WIXAV. The subject being televised is "Big Brother" Bob Emery, conducting his regular Wednesday night Lighthouse survey. He made use of a visual signature in the form of a miniature flashing lighthouse. At the extreme left is the arc which throws a brilliant ray through holes spirally arranged in the whirling scanning disc. The ray plays over the features of the subject, and is picked up from four different angles by the four giant photo-electric cells before which Emery is standing.

NOTE—This photograph was taken when vertical scanning was still in use.

MAKING TELEVISION HISTORY IN HUB

On Wednesday evening, February 5th, 1930, another progressive step was taken in the history of Television transmission. The first broadcast of synchronized voice and vision as part of a regular program was successfully completed by WEEI, the 1,000 watt broadcasting station of the Edison Electric Illuminating Company of Boston, in conjunction with our 500 watt Television station W1XAV.

The program transmitted was the regular evening feature of Bob Emery, the famous "Big Brother," who incidently adopted for the first time in radio history a visual signature in the form of a model lighthouse which flashed intermittently. The combined transmission of sound and pictures was accomplished by the program emanating from our studios and the voice being carried through our amplifiers to a regular telephone toll line, which carried it in turn to the WEEI broadcasting station at Weymouth, whence it was broadcast on 508 meters. The Television picture was transmitted directly from our own station W1XAV on 141 meters.

This inauguration of the broadcasting of combined voice and vision opens a new era in radio. It does not need much imagination to anticipate the time in the near future when the transmission of synchronized voice and vision and its reception will be as common as ordinary radio reception is today.

TELEVISION KITS

It will be a readily accepted fact, which is true of every new product, that it will be impossible to produce such a highly perfected machine as the Baird Universal Televisor at a price commensurate with everybody's pocket-book. Although the price of this receiver is not abnormally high we nevertheless feel that a Television receiver in kit form at a much less price would be acceptable to that portion of the public which always derives pleasure in "building their own." Such kits are now on the market. They comprise a vertical motor, our own scanning device with the belt attached to the spider, framing device, Neon Lamp and lens. All of these units can be easily assembled by the set-builder and it will simply necessitate the building of a wooden box which will house the Television chassis and also support the Neon lamp and lens.

We will be glad to give every possible help to those who wish to experiment in the construction of their own Television and Shortwave equipment. We will furnish on request complete information for the construction and assembly of shortwave receivers and Television Kits. A circuit diagram of an efficient Television shortwave receiver is shown on the opposite page.

AN EFFICIENT TELEVISION SHORTWAVE RECEIVER

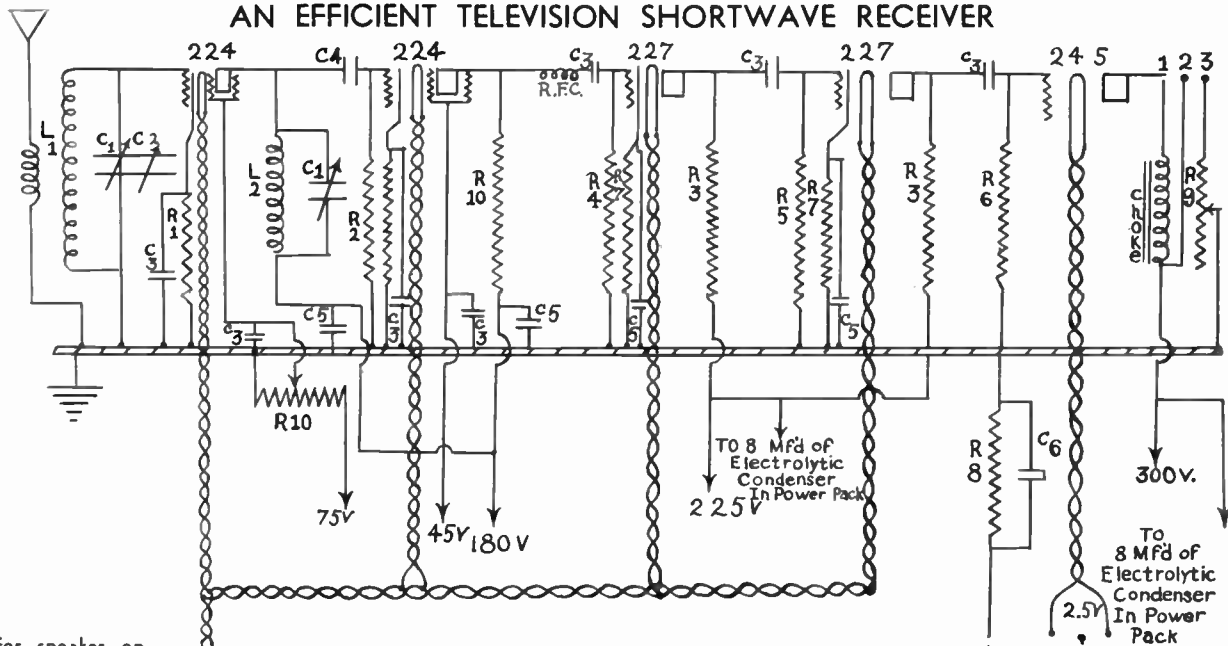

31

For speaker operation connect terminals of speaker to 1 and 2.

For Neon Lamp connect to 1 and 3.

- L1} Shortwave and Television Red
- L2} Octocoils
- C.1—11 plate bath tub .000164 var. cond.
- C.2—.0001 14 plate midget var. cond.
- C.3—.25 mfd. coup cond.
- C.4—.00015 grid cond.
- C.5—1 mfd. by-pass cond.
- C.6—2 mfd. by-pass cond.
- R1—400 ohm bias resistor
- R2—1 megohm grid leak
- R3—50,000 ohm resistor
- R4—1/2 megohm leak
- R5—1/2 megohm leak
- R6—1/4 megohm leak
- R7—4000 ohm bias resistor
- R8—1800 ohm bias resistor
- R9—4000 ohm variable resistor
- R10—100,000 ohm resistor
- R.F.C.—S. W. & T. Radio Frequency Choke
- Choke—30 henry 60 mill. choke

Shortwave and Television Laboratory, Inc.

70 BROOKLINE AVENUE
BOSTON, MASS.

Owners and Operators of
TELEVISION STATION W1XAV

Cable Address
"Television" Boston

Telephone
Commonwealth 3520



Export Department
15 LAIGHT ST., NEW YORK

Cable Address
"Arock" New York—All Codes

Over 20,000 square feet of floor space
devoted exclusively to the
manufacture of
SHORTWAVE AND TELEVISION
Apparatus and Equipment

