

FILAMENT TRANSFORMERS. Heavy duty. 10v. C.T. at 10 amps. 6.3v. C.T. at 4 amps. 210-230v. 50 Cycles input - 22/6 each
Filament Transformers. R.C.A. 10v. C.T. twice. for pair 817's. 190-250v. 50 Cycles input. Potted 22/6 each
H.T. Transformers. 230v. Input. Single 350v. at 60 ma output. Secondary Isolated - 7/6 each
Driver Transformers. S.T. & C. Single Plate to PIP grids. Tapped primary to give ratios 1. to 1.1. or 1.1. to 1. Primary to half split secondary suitable for most pentodes to drive PIP 807. Fully Potted. Size $3\frac{1}{2} \times 3\frac{1}{2} \times 2\frac{1}{2}$ - 7/6 each
Condensers. Block Paper. 5 mfd. plus 3 mfd. 750 v.Wkg. - 5/- each
Pre-Amps. Ultra S.W. uses EF54 with Coax input and output sockets for power supply input. Broad Band slug tuned for use on T.V. frequencies or 10 metres. Valves to suit available - 5/- each
Crystal Monitors.. Type 2 For frequency checking of Transformers and receivers. Provision for phones. Battery Operated. Easily adapted for mains by using 3-6J5 valves. Housed in attractive cabinet with red panel indicator light. Size $7\frac{1}{2} \times 5\frac{1}{2} \times 5$. Circuit 11-extra - 7/6 each
Meters. Markes Air/Oil. Moving Coil basic 200 microamps. Very sensitive - 7/6 each
Loop Aerials. 1155 D.F. - 8/6 each
Hand Mikes. Tannoy Power. Carbon Type. With press to talk button - 3/6
8 mfd. Condensers. 350 v.wkg. Screw-hole fixing. 2/-
Twin Screened Cable - 1/- per yard
Rectifiers. 12v. 2 Amps. - 12/6 each

Please Add Something for Postage

NORMAN H. FIELD

68 Hurst Street, Birmingham, 5

Have Your Copies
Bound

VOLUMES OF RADIO CONSTRUCTOR AND RADIO AMATEUR FULLY BOUND IN IMITATION LEATHER, WITH GOLD LETTERING. 7s. 6d. POST FREE. PRICES FOR OTHER PUBLICATIONS ON APPLICATION.

IF NOT REQUIRED TO BE BOUND IN, REMOVE COVERS BEFORE SENDING.

JEROME ALCOCK
 CHEADLE, STOKE-ON-TRENT

FRED'S Radio Cabin

Olympic Coil Packs, 3 Wave Band	24/6
AC/DC Amplifiers	£3.15.0
AC. TRF Midget Scts	£6.10.0
Tyana Soldering Irons	16/9
Sleeving (12 yds.)	2/9
400Ω w/w Pots	2/6
VR54	2/6
6K, 7K, 10K, 30K, w/w 2ow Res	1/6
50 pF and 20 pF Ceramic Trimmers	1/-
3P., 3w., WCS	2/3
Indoor T.V. Aerial	7/6
10 Amp. Mains Filters	10/-
4P., 2w., WCS	2/6
8 way Jones Plugs, 1/-	6 pin, 6d.
3 Link Aerial Insulators	6d.
1", 1½" Plastic Tube	1/- yard
Yaxley Wafers, 2P., 4w.	3d. ea., 2/6 doz.
.005/1,000 volt. Tubular Condensers	6d.
.5 and .25, 350 volt	6d. ea., 4/- doz.
240,000Ω, 5w., Carbon	6d. ea., 4/- doz.
.0003 T.C.C., Mica Condensers	6d. each

77 NEWINGTON BUTTS
ELEPHANT AND CASTLE
 LONDON SE 11
 RODNEY 2180

IN EVERY RADIO SET THERE ARE

500 reasons why you should use . . .

The average radio set contains about 500 soldered connections — make sure of perfect reception by using only Ersin Multicore for all soldering on your equipment.

The three cores of extra-active non-corrosive Ersin Flux not only prevent the formation of oxides, but actually clear the oxides from the metal to be soldered, saving time and trouble, and ensuring the highest standard of sound precision soldered joints.



MULTICORE SOLDERS LTD.
 MULTICORE WORKS, MAYLAND AVENUE,
 Hemel Hempstead, Herts. Boxmoor 3636 (3 lines)

CLYDESDALE

Bargains in Ex-Service Equipment

**SPECIAL OFFERS
MINIATURE VOLUME CONTROLS**
(Carbon Track)

- Dia. 1 1/2 in. single hole fixing (Standard).
H893 2 Megohms. (log) with 1 1/2 in. spindle DPISwitch
4/- each, post 3d.
H894 1/2 Megohm. (log) with 1 1/2 in. spindle DPISwitch
4/- each, post 3d.
H895 1/2 Megohm. (log) with 1 1/2 in. spindle, no switch
2/6 each, post 3d.
H896 1/2 Megohm. (linear) with 1 1/2 in. spindle, no switch
2/6 each, post 3d.

AMMETER RANGE 0-20

2in. round clip mounting with ext. shunt. Res. 00375 ohms.

ASK FOR **12/6 EACH** POST PAID
No. CIH892

MILLIAMETER RANGE 0-5

2in. square drilled flange

ASK FOR **12/6 EACH** POST PAID
No. CIH537

METAL CASED PAPER CONDENSER

4 mfd. capacity, 2,000 V.D.C. Test. Dim.: Overall, 5 1/2 x 4 x 1 1/2 in.

ASK FOR **4/6 EACH** POST 3d.
No. CIH860

NEW LIST No. 8D Now in the press—Price 1/6d.
Price Credited on first purchase of 10/-, or over.

Order direct from: Tel.: South 270619

CLYDESDALE SUPPLY CO., LTD.

2 BRIDGE STREET, GLASGOW, C.5

Branches in Scotland, England and North Ireland

CONTENTS

	<i>Page</i>
Radio Telescopes - - -	4
Radiation Patterns with Model Aerials - - -	6
Putting us over - - -	12
Modulating a Simple Rig - -	13
The Design of Mains Transformers The Auto-Transformer. Part 5. -	15
“Technical Award” Double Superhet	19
Broadcast Bands Review - -	24
On the Higher Frequencies - -	28
Amateur Bands Commentary - -	34
Club News - - -	38
1952 RSGB Exhibition - - -	39
Book Review - - -	39

Come to SMITH'S of EDGWARE ROAD
the friendly shop for all Radio Components

We stock everything the constructor needs—our 25 years experience of handling radio parts and accessories enables us to select the best of the regular lines and the more useful items from the surplus market in :—

- | | |
|-------------------------|--------------------------|
| Loudspeakers and Phones | Valves and CR Tubes |
| Transformers and Chokes | Cabinets and Cases |
| Meters & Test Equipment | Capacitors and Resistors |
| Pickups and Turntables | Coils and Formers |
| Switches and Dials | Plugs and Sockets |
| Metalwork and Bakelite | Aerials and Insulators |
| Books and Tools | Motors and Generators |
| Valve Holders and Cans | Wires and Cables |
| Metal Rectifiers | Panel Lights and Fuses |
| | Recorders and Parts |
- Sleeving, Nuts and Bolts, Tags, Clips, Grommets and all other bits and pieces.

**NOTHING TOO LARGE—
NOTHING TOO SMALL**

Everything you need under one roof—including all the parts specified for the popular “Viewmaster” Home-built Televisor, both London and Birmingham models.

No general catalogue is issued owing to constantly varying stocks and prices, but we shall be pleased to quote you.

H. L. SMITH & CO. LTD.
287/9 Edgware Road, London, W.2

Telephone : Paddington 5891.
Hours 9 till 6 (Thursday, 1 o'clock).
Near Edgware Road Stations, Metropolitan and Bakerloo.

The RADIO AMATEUR

Vol. 8 No. 1

January

incorporating "SHORT WAVE NEWS"

Editorial & Advertising Offices : 57 Maida Vale, London, W.9

Tel. CUN. 6518

EDITOR : Arthur C. Gee. G2UK.

Annual Subscription 18s.



EDITORIAL

The new regulations which will enable the Postmaster-General to enforce the fitting of suppressors on new petrol engines after July 1st, is certainly a step in the right direction. Whilst this regulation is primarily directed at giving that pampered pet of the electronic industry—television—further protection, it will be much appreciated by we long-suffering radio amateurs. It will indeed be nice to have some of the QRM removed from our higher frequency bands, and our SWL readers are no doubt thoroughly in favour of "more television for more people" if this is the sort of legislation it brings! They at least will be able to enjoy their hobby in even greater peace.

For the amateur transmitter, however, these regulations represent a still further reminder—if it be necessary—that the authorities will not tolerate any electrical interference with the TV service, no matter what its origin. Amateur radio transmitters of the future must be as TVI proof as they can reasonably be made.

We do feel, however, that this burden of TVI proofing should be fairly distributed, and as one of our contributors last month

showed, much more can—and should—be done at the televisor end. In some ways the position resembles that which worried us in the pre-war days in regard to BCI. In those days, the old-fashioned TRF broadcast receivers always produced a crop of BCI complaints, no matter what one did at the transmitting end. As these receivers were replaced by more modern ones, so BCI complaints vanished, until nowadays, BCI from amateur transmitters is almost unheard of.

Your editor lives in an extreme fringe area of the London TV service. Within a hundred yards of his QTH, there is a well-screened televisor, complete with preamplifier and high directivity aerial system, which experiences no TVI at all from the 14 Mcs. 150 watt phone transmitter. Nearly a mile away, is another much less elaborate television set up, which is badly affected.

Whilst we appreciate that everything must be done on the transmitter to mitigate TVI, we do feel that rather more encouragement should be given to tackling the problem at the televisor end than is customary at the moment. —2UK.

THE CONTENTS of this magazine are strictly copyright and may not be reproduced without obtaining prior permission from the Editor. Opinions expressed by contributors are not necessarily of the Editor or proprietors.

THE EDITOR invites original contributions on short wave radio subjects. All material used will be paid for. Articles should be clearly written, preferably typewritten, and photographs should be clear and sharp. Diagrams need not be large or perfectly drawn, as our draughtsmen will redraw in most cases, but relevant information should be included. All MSS must be accompanied by a stamped addressed envelope for reply or return. Each item must bear the sender's name and address.

Component Review. Manufacturers, publishers, etc., are invited to submit samples or information of new products for review in the section.

CHEQUES and Postal Orders to be made payable to "Amalgamated Short Wave Press Ltd."

ALL CORRESPONDENCE should be addressed to "The Radio Amateur," 57 Maida Vale, Paddington, London, W.9. Telephone CUN. 6518.

A Companion Journal to THE RADIO CONSTRUCTOR

RADIO TELESCOPES

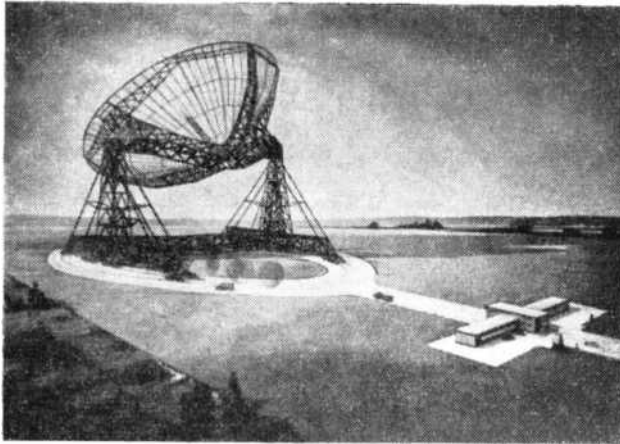

Scale drawing of a new steerable Radio Telescope which will have an Aerial 265 feet in diameter. The Telescope will be installed at the Manchester University Experimental Station at Jodrell Bank, Cheshire.

During the 18th and 19th centuries, our knowledge of the universe around us grew rapidly through the development of very large astronomical telescopes. Still further progress in this sphere was made when the 100 and 200 inch aperture telescopes came into operation on Mount Wilson and Mount Palomar in America. By means of these later two instruments, star systems so remote that light from them would take hundreds of millions of years to reach this planet, have been revealed. It is a well-known fact that most of the energy output from a hot body, such as the sun or stars, takes the form of visible rays. Astronomers, therefore, were quite confident that their telescopes were giving them all the information they needed to construct a true picture of the universe and outer space.

In 1931, however, an American scientist, Jansky, made the very surprising observation that radio waves were reaching the earth from outer space. Very little notice was taken at the time of Jansky's observations, but—and this is particularly interesting from our point of view as amateur radio experimenters—his work was followed up by an amateur experimenter named Reber, who actually built what must be regarded as the first "radio telescope" in his back garden. 30 ft. in diameter, it was constructed to resonate at about 2 metres. It was rotatable and could be pointed towards different parts of the sky. Reber confirmed much of Jansky's work and discovered that particular "areas" of the

universe, such as the Milky Way, were more prolific of radio waves than others.

Very little official notice was taken of this work, however, and by the end of the last war it was generally accepted that these radio waves were generated by atomic processes in the rarified hydrogen gas in interstellar space.

During the war a great deal of progress was made in radio and radar techniques, particularly in the high frequency ranges, and when hostilities ceased, some of this equipment was used to investigate Jansky's and Reber's claims. Generally speaking, two types of aerial systems were used. One was that of using two separate aerials separated by a distance of several hundred yards and connected to a common receiver. As explained in the article "Radio and Astronomy," which we published in this magazine last May, by means of "interferometry," some idea of the place in outer space from which these waves were coming, could be worked out. These "radio interferometers" were developed to give quite accurate measurements, and it became apparent that there were quite well localised areas in outer space from which these waves were coming. The localisation was sufficient to justify the description of "radio stars" to these areas, even though no known visual star system could be correlated with them. The exact nature of these radio stars is one of the problems which astrophysicists have yet to solve.

THE RADIO AMATEUR

Professor Lovell, of Manchester University, came to the conclusion that the best equipment for solving these mysteries was the type of aerial which would receive a narrow band of waves. This would have to be rotatable and capable of being directed at any part of the universe. Several experimental radio telescopes of the type originally used by Reber have now been built, one of which at the Jaded Experimental Station, Cheshire, we illustrate herewith.

As most readers of this magazine will be aware, during the past few years radio waves have been discovered coming from the sun. The study of these is throwing new light on conditions in the solar atmosphere. Sunspots and solar flares similarly emit radio energy. Further uses to which these radio telescopes can be put is in investigating the aurora borealis, by transmitting pulses of radio energy from the telescope aerial and ascertaining the nature of the reflected wave. A similar technique has been developed for studying meteors and the fact that the radio telescope can of course be used in daylight and in cloudy weather has revealed that great showers of these meteors pass the earth on its sunlit hemisphere, they having up till now been

completely invisible by normal observation.

As work in this sphere progressed, it became more and more apparent that a really large version of the smaller steerable parabolic type of aerial shown in our photograph was required. Thanks to the generosity of the Nuffield Foundation and the co-operation of the Department of Scientific and Industrial Research, the construction of this giant instrument has already started. As can be seen from the artist's impression of the final project, which we reproduce herewith, this will be quite an engineering feat, apart from its radio uniqueness. It will be the largest radio telescope in the world and will place in the hands of those pioneering scientists in Manchester and Cambridge an instrument equal in possibilities to the great 200 inch American telescope on Mount Palomar. The diameter of the paraboloid aerial will be 250 ft. and the diameter of the platform on which it rotates is 310 feet. The height to the axis is 185 feet and to the top of the parabola is 300 feet. The total weight will be 1,270 tons. A most interesting feature is that the two main elevating racks at each end of the horizontal axis have been obtained from the battleships "Revenge" and "Royal Sovereign," which were recently broken up.

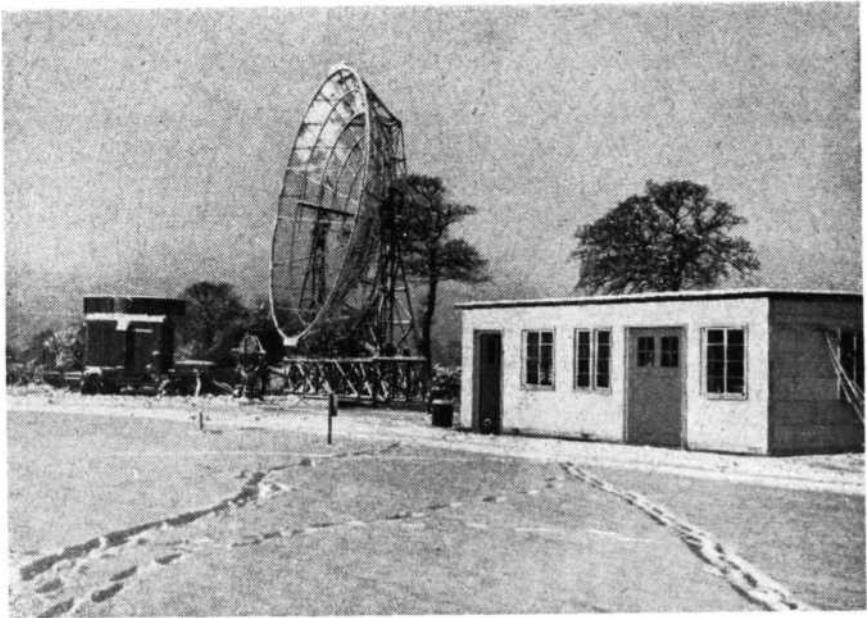

30 feet aperture experimental radio telescope installed at Manchester University

RADIATION PATTERNS AND OTHER MEASUREMENTS WITH HIGH FREQUENCY MODELS OF AERIALS

by F. C. JUDD, G2BCX

Part 3.

When plotting radiation patterns from model aerials certain conditions must be maintained irrespective of the frequency of operation. These conditions are discussed in the following together with some notes on making other measurements such as those of gain, polarization and so on. At all frequencies clear surroundings are very necessary and the models and associated equipment should be carefully sited several wavelengths (at operating frequency) away from buildings, other conductors such as electric light wiring, pipes, metal window frames; in fact anything that is

metallic and near resonant length either fundamentally or harmonically, will reflect. Reflected signals picked up either by the F/S aerial or reradiated from the test aerial may be in or out of phase with the direct signal. Such conditions would give rise to false readings. For the same reason standing-wave on feeder lines must, as far as possible, be eliminated. These conditions are important if accurate results are to be obtained from aerials of unknown quantity.

The field strength meter should be located at a distance of at least 5 wave-lengths from

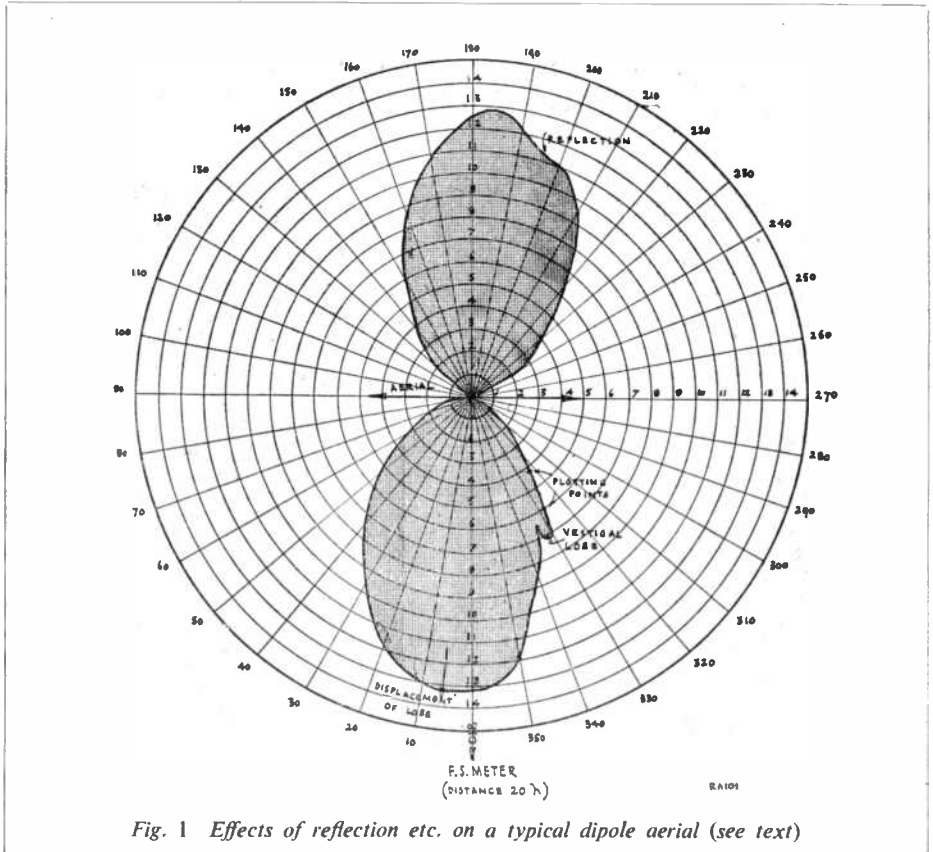

Fig. 1 Effects of reflection etc. on a typical dipole aerial (see text)

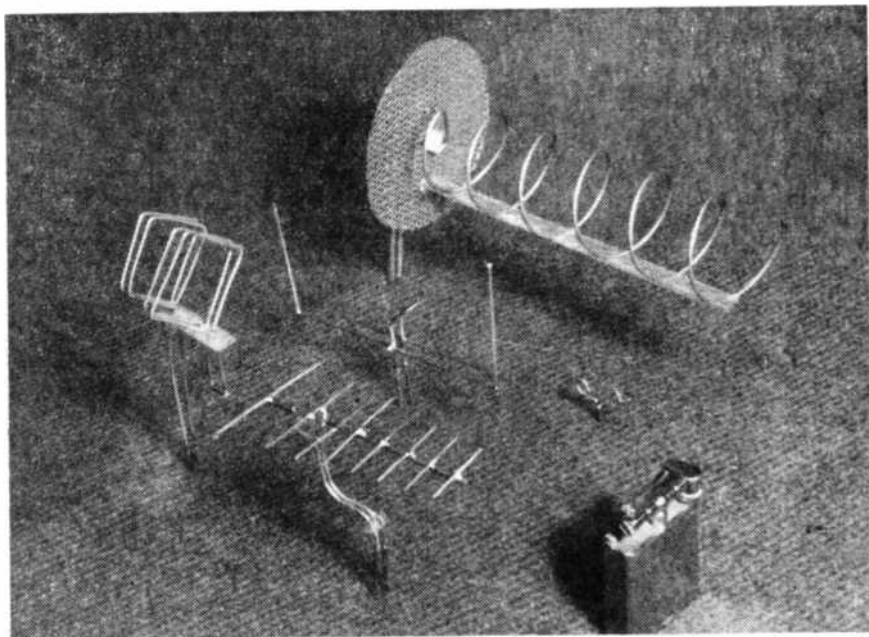

Fig. 2 Group of model aerials for 3000 Mc/s. Top right, 6 turn helix, 1st mode. Centre left, two element "Quad." Centre, two element vertical "end fire" array. Centre bottom, eight element Yagi array. Centre right, just visible above lighter, a folded halfwave end fed aerial.

the test aerials when horizontal or vertical patterns are being plotted, or gain is being measured. It is advisable to construct one aerial (a dipole), make sure that it is accurately matched and has no standing-wave on the feeder. Sample radiation patterns should be plotted in two planes, and conditions adjusted until a perfect, or near perfect pattern is obtained. The conditions should be maintained for all other aerials and measurements. The *standard dipole*, which is best mounted half a wavelength high, can be used for comparing the gain of other aerials, in which case the dipole is accepted as having a gain of zero Db.

As the frequency of operation is increased, reflection becomes more troublesome and at the centi-meter wavelengths the body will radiate quite strongly as also metallic objects which may be worn by the operator, spectacles, etc., or carried in the pockets,

fountain pens, metal pencils and so on. The writer operates the aerial table described in part 2 by sitting on a low stool so that the whole of the body is below the table top, and for this reason a bearing indicator is fitted underneath the table. Trouble may also be experienced with reflection from electric light wires and other objects in an ordinary room; particular note of this should be made when plotting vertical patterns.

An example of a radiation pattern from a dipole (Fig. 1) shows the effects of reflection from nearby objects. In the top right-hand portion there is a depression due to reflection and in the lower half a secondary lobe appears. Note also that both main lobes are displaced by a few degrees; an effect which may be due to poor current distribution, standing-wave on the feeder, unbalanced feed, off center feed point on the aerial and so on. Once a perfect pattern has been plotted from the

*Fig. 3
Three dimensional model
made up to show radiation
from aerials.
(see text)*

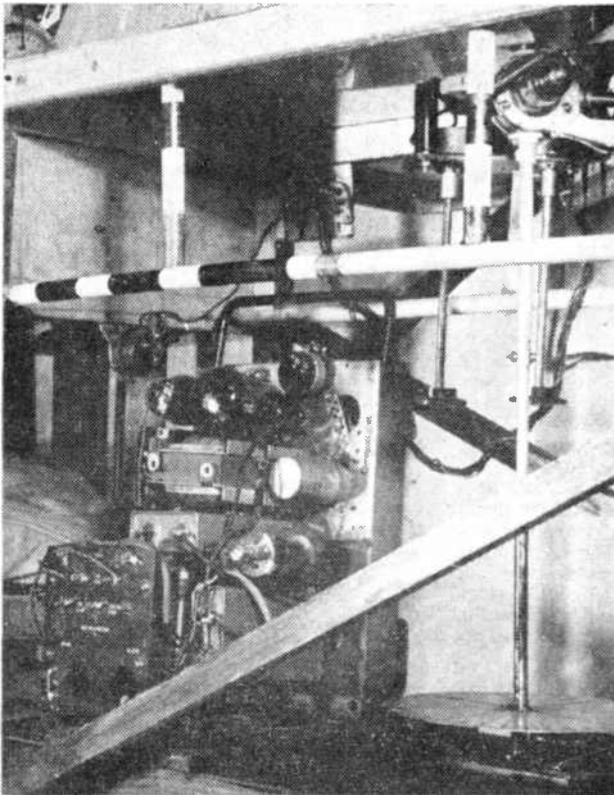
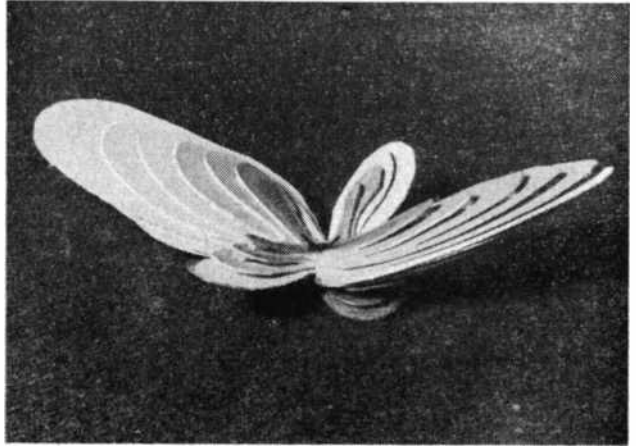

*Under table view of the
model aerial testing table
described last month. The
shaft by which the model
aerials are rotated can be
seen together with its indi-
cating dial. The power
pack, transmitter, etc. are
also shown.*

standard aerial the conditions for such should be maintained for all other aeralis and this respect the frequency of operation, power output from the oscillator, and F/S meter aeralis must be included and remain constant. A little time spent in determining the most ideal condition available is worth while.

Simulation of the Effects of Surrounding Structures

The importance of clear surroundings will be appreciated when attempts are made to simulate conditions associated with full scale aeralis. The effects of buildings, other aeralis, masts, and so on, may be accounted for by constructing models. Certain materials are difficult to simulate, particularly with other kinds of material, but much can be done with substitutes. Metallic structures may be simulated with metal as in the case of a complete model of the internal wiring, pipes and downspouts likely to be found in an average house (see Part 2). The writer has constructed a model of a small factory with a tall chimney and such items as metal roofs, internal wiring and pipes and the lightning conductor on the chimney have all been included in the model. Aircraft aerial systems are tested in this way by using a model of the aerial mounted on a model of the aeroplane on which it is to be used. Both models are constructed on the same scale, and in scale relation to the frequency of operation. Effects of the shape of the aircraft, fabric used in its construction and so on may be simulated. Many tests may be carried out with only a few model aeralis and some are listed as follows:—

Effects of:—

1. Height above ground.
2. Feed point on the aerial (single wires).
3. End effects. Presence of metal masts, etc.
4. Reflection from nearby conductors.
5. Changes of polarization between transmitting and receiving points (due to ground effects and reflection).
6. Folding—long wires and small beams.
7. Different feeder and matching systems (confined mainly to the lower model frequencies 100 to 500 mc/s).

Any one or more of the above should be applied to any one aerial so it may be seen that quite a few combinations are possible as well as numerous other experiments, such as the measurement of free space wave-length, wave fronts and phasing, etc.

Model Aeralis

The actual construction of model aeralis depends entirely on the frequency of operation. For the lower frequencies (7 above) quite accurate models may be constructed and scale size details such as insulators, framework for arrays and beams, supporting masts and towers and feeders may be included. Long wire aeralis may be made from thin wires and beams of the self supporting type fashioned from small diameter aluminium or copper tube of scale size. Insulators may be made of distrene or mica. Scale model 600 ohm open-wire feeder line is quite practicable, and the writer has constructed several lengths from thin wire suitably spaced with strips of P.V.C.; the wire is "moulded" into the P.V.C. with a hot iron. At centimeter

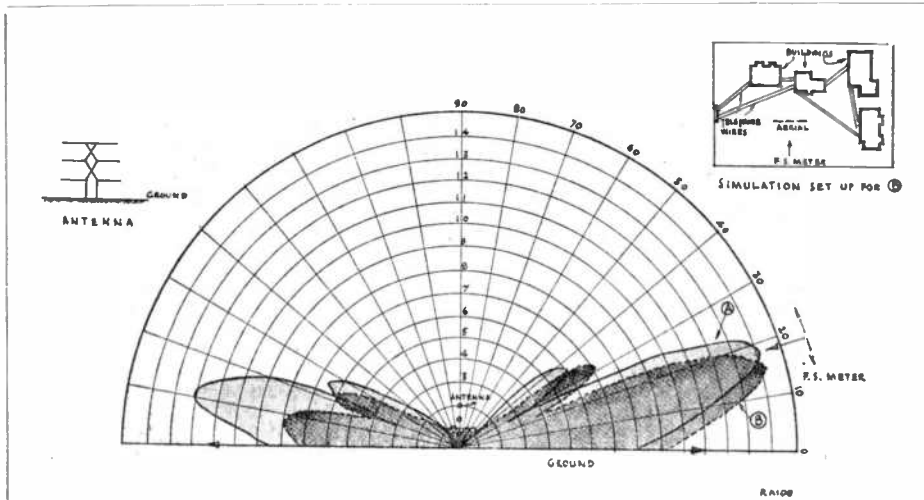

Fig. 4 Showing A, pattern from free aerial ; B, pattern taken with buildings as per insert.

The

RADIO AMATEUR

Vol. 8

Number 1

JANUARY

1953

inc. "Short Wave News"

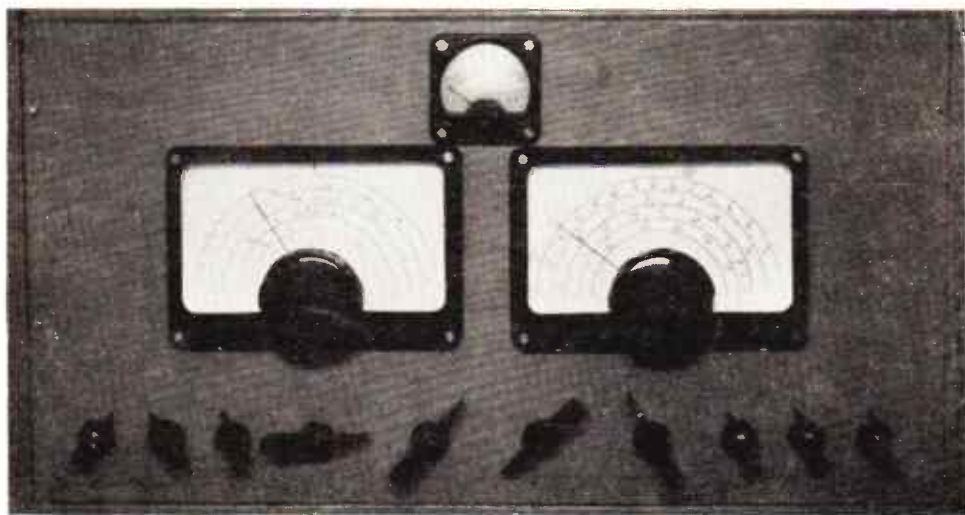

"Technical Award" DOUBLE SUPERHET, described within.

IN THIS ISSUE . . .

Radio Telescopes. Radiation Patterns with Model Aerials. Putting Us Over. Modulating a Simple Rig. The Design of Mains Transformers. "Technical Award" Double Superhet Broadcast, Amateur and VHF News. Club Notes, etc., etc.

16

Coronation QSL's

Why not send a distinctive QSL this year? Special designs to celebrate Coronation Year available from G6MN who has supplied 'special' QSL's for discriminating users all over the world.

Attractive "Coronation - 1953" designs now available from

**G6MN, Castlemount,
Worksop, Notts.**

The Radio Amateur Operator's Handbook

This publication is a successor to our very successful "OP-AID". Completely revised and with additional information, it is even more useful than that publication was and we advise you to order straight away.

For those who did not see our "OP-AID" may we say that it contained all those details of information which the radio amateur and SWL constantly require. Right up-to-the-minute Amateur Band Prefix lists, both alphabetically and by country, Zone Boundaries, Call Areas, Mileage Tables, QSL Bureaux, "Q" and "Z" Codes, WWV Skeds, and much other information, as well as a selection of maps of DX areas.

This is an indispensable Handbook for every amateur radio station.

Price 2/6, postage 2d.

DATA PUBLICATIONS. 57 MAIDA VALE, W.9

IKOPATENTS

LTD.

Managing Director
E. G. O. ANDERSON

Consultants

- *RADIO*
- *TELEVISION*
- *ELECTRONICS*

17 CRISP ROAD, W.6
RIVERSIDE 2678

LAWRENCE HAS YOUR ANSWER

If you are on DC MAINS 200/240
WE HAVE SMALL ROTARY
CONVERTERS.

Complete with interference
suppressors for 6v. 12v. 24v. DC
output. Price 35/- P.Pd.

If you are depending on batteries
we have Rotary Converters 6v.
12v. 24v. input giving HT 200 to
500v. to meet all requirements

*S.A.E. for comprehensive list of
Radio, Model Railways, Battery
Charging, Technical Books.*

**LAWRENCE FRANKEL MAIL ORDER,
134 CRANLEY GDNS., LONDON, N.10**
TUDor 1404.

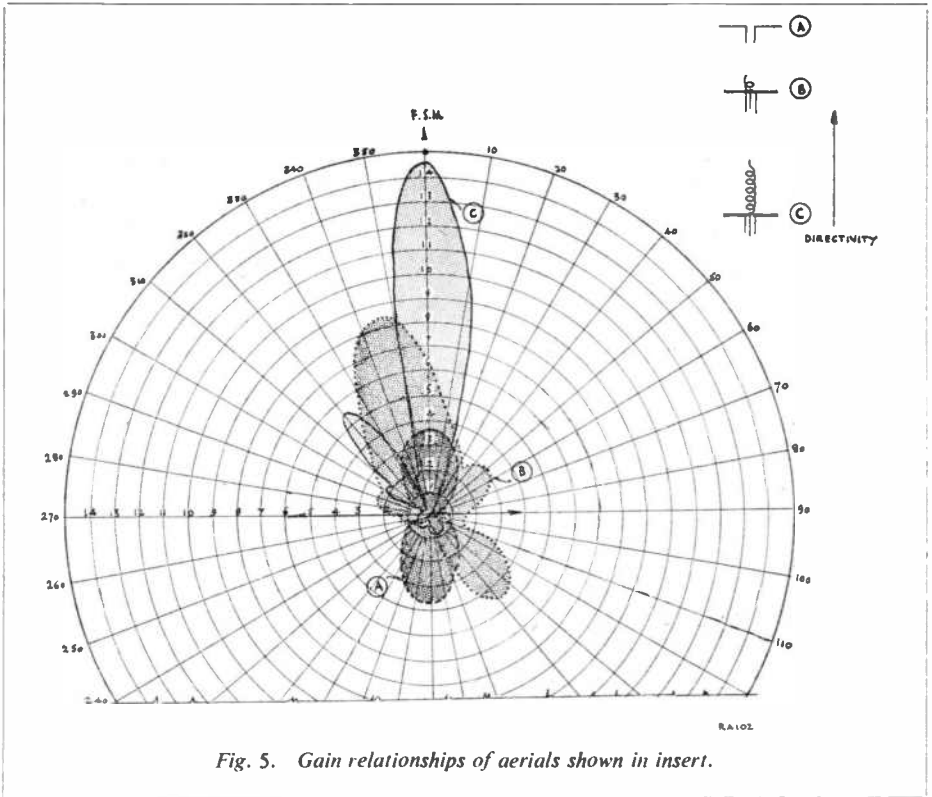

Fig. 5. Gain relationships of aerials shown in insert.

wavelengths the construction of feeder systems is a little more difficult but much can be accomplished with small diameter brass tube and 18 s.w.g. tinned copper wire. Tiny "Q" matching transformers of brass tube can be used to affect changes in feed impedance and may be connected with feeders constructed with 18 s.w.g. wire which in most cases will support the aerials as well. Thin brass tube is available in several diameters, and is obtainable from stockists of model-making materials. (See photo Fig. 2).

Radiation Patterns

Plotting radiation patterns from models is rather a slow process, unless automatic recording gear is available, but nevertheless can be quite interesting since in many cases the results may be compared with the calculated theoretical patterns shown in most radio handbooks. Three dimensional models of the patterns may also be constructed, and from these a far better conception of the directivity of an aerial may be obtained. Such models are made by taking patterns from the aerial every few degrees in either

the vertical or horizontal plane. To make this a little clearer the one shown in Fig. 3 was made by plotting the horizontal pattern at 0, 10, 20, 30 degrees and so on up to 90 (or through to 180 if the pattern extends right round the aerial) in a vertical direction. Each pattern is then drawn on thin cardboard, cut out and glued together in the correct order. They may also be suitably coloured to show the strength of radiation at each angle or group of angles.

Plotting radiation patterns is a fairly simple task since all that is necessary is to take a field strength reading every few degrees in the desired plane. Either the field strength meter may revolve round the aerial, or the aerial may rotate on its own axis with the field strength meter aerial fixed in position at zero degrees. If the aerial is made to rotate, any applied effects must rotate with it. It has been found that for reasonably accurate horizontal patterns from simple aerials, plots every 10 degrees are sufficient; 5 degrees in the vertical plane are necessary. For higher accuracy and to include the sharp directivity of minor lobes, plots

every 5 degrees (horizontal) and every 2½ degrees (vertical) are essential. Some examples of patterns taken from model aerials on the writers 3000 mc/s testing table are shown in Figs. 4, 5 and 6. Fig. 4 shows the vertical radiation from a six element stacked array with and without the effects of nearby telephone wires and buildings, and Fig. 5 illustrates the differences in horizontal directivity of A, a Dipole, B, a single turn Helix with reflector, and C, a 10 turn Helix also with reflector. This latter aerial produces a forward gain of 17 to 18 DB over a horizontally polarized half wave antenna. Ref. 1. Radiation from Helical aerials is circularly polarized. Fig. 6 shows three patterns taken from A, a Dipole, B, a three element parasitic array, and C, an eight element parasitic array. Patterns are for the horizontal field and gains are relative.

the average Amateur. Whilst the results with home constructed apparatus may not be up to laboratory standards, such a system, even on a small scale, can provide much interest especially when used for demonstrations to groups of local Amateurs. The lower frequencies of 100 Mcs to 500 Mcs (mentioned in previous paragraphs and parts 1 and 2) could be used since quite detailed model aerials may be constructed complete with scale size insulators, wooden towers, beam supports, etc., all of which adds to the interest and effectiveness of indoor or outdoor demonstrations. Finally, thanks are due to those who from time to time have rendered great help with special tests and in many cases given assistance at various demonstrations with equipment including models of over a hundred different aerials.

Conclusion

The writer has endeavoured to provide as much information on measurements with models of aerials as space will allow. All the equipment has been constructed from various components and materials within the reach of

Ref. 1. Helical Beam Antenna. J. D. Kraus. Electronics, April, 1947.

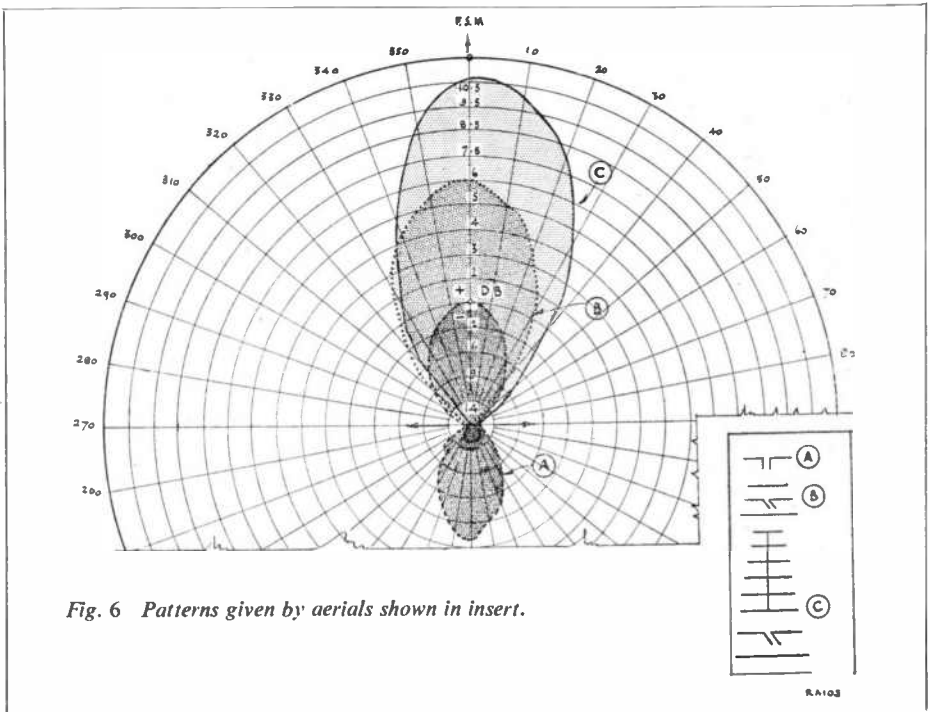

Fig. 6 Patterns given by aerials shown in insert.

PUTTING US OVER.

by ROY SAVILL

It must at times strike most of us how appallingly ignorant the average person is about our hobby—whether we be a fully-fledged operating amateur or a S.W.L. By too many we are regarded as people who are just a bit cranky (well, perhaps we are !), or, particularly if we are a transmitting amateur, as the source of every bit of interference that occurs on both TV and ordinary radio listening.

Something should be done about it. And to me it has always seemed that one of the best ways of getting ourselves across in the proper perspective is by giving talks to local clubs and organisations, such as Round Table, Rotary, Toc H, to mention only a few. In fact there can hardly be a town or village that has not got a fellowship or group; the churches are bound to have them.

Practically all of these groups are only too pleased to have someone go along and give a talk on a subject that is a little out of the ordinary. They can always get someone on a dry-as-dust topic, and a welcome will assuredly be awaiting any one of us who cares to approach them.

It must be remembered that the majority of these groups are idealist in purpose, that is, they exist to further good fellowship, understanding, and to broaden outlooks. And, more, they are nowadays extending their interests into the international sphere. To those of us whose radio hobby is based at least partly on the same ideals, there is much that we can offer.

We can show how we establish friendships both in Britain and all over the world by way of the amateur bands, and of how, as S.W.L.'s we get a broader view of the people of other countries. Even if the radio does not achieve for the world a complete Utopian state of good will, the educational aspect should not be overlooked. It is astonishing how a short wave listener gains a knowledge of the ways and characteristics of the peoples of other countries, of their history and about languages—to say nothing of learning more about geography than any school teacher ever taught him.

It is unlikely that an audience will need telling of the way in which the air is choked with propaganda, but they might like to know how well an experienced listener can sought out the wheat from the chaff, and of how he develops a mind that is at once open and critical.

I hope no-one will be put off from the idea of "putting us over" because he thinks he

cannot "speak." Most of the local groups I have in mind are very informal and friendly in their meetings, and what they want is something on the lines of a chat, followed by a general discussion, rather than a "lecture."

It might well be a good idea to take a receiver along to the meeting—an aerial sufficiently good for what is needed can easily and speedily be rigged. Then, the speaker can lead up to giving an actual demonstration on both the amateur and BC bands, giving explanations as he goes along.

Have you ever thought of the percentage of modern receivers fitted with a short wave band that is no less than a white elephant to their owners? Thousands have no idea what is on that band, many having never turned the switch to investigate, and many others have turned it once and once only because their lack of knowledge produced nothing but the most unholy noise.

Now, how are you going to set about the task of "Putting us over" at one of these meetings? To those who have not thought much about it I would suggest something on the following lines:—

A selection of QSL cards and, if you are a BC SWL, some of the literature and other publications, brochures, etc., sent by the various stations are good things to take along to create additional interest and to pass round at a convenient moment.

The talk itself could be opened with introductory remarks about the extent of amateur radio; about the number of licensed amateurs there are in Britain and in the world, and, on the BC side, about the enormous numbers of SW stations there are and the organisation behind them, how they are helped by reports from listeners.

Then you can proceed to classify, splitting your references into sections about the licensed amateur, the SWL, short wave BC, radio clubs and so on.

You may feel that a brief chat about equipment used and comparative powers of transmitters would not come amiss—without being too technical. You might tell your audience about the part played by amateurs in the progress of the science of radio. They might be told, too, of the established low percentage of TVI caused by amateurs.

A few words about the operating "code"—slang, abbreviations, the Q Code, and so on—would probably be worth while. If you can put over an idea of the thrill behind DX so much the better. Then, before the general discussion, you could give the demonstration.

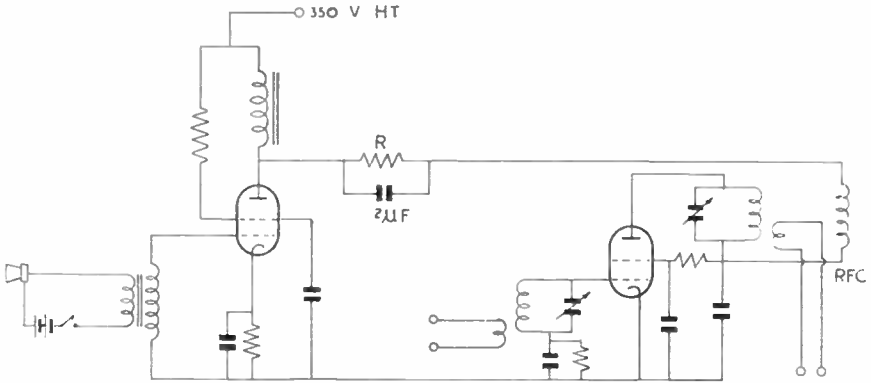

FIGURE TWO

RA-220

Heising system modified to enable an amplifier to be modulated 100%. R should drop about 50 volts and values in practice are about 1000 ohms with low power rigs.

modulator valve. Due to the impedance of the LF choke, the audio signal is impressed upon the HT supply to the modulated stage, thus effecting modulation. Such a system is generally quite uncritical, and easy to get going. To obtain effective modulation, some attention to details is necessary. The choke for example must be capable of standing the combined anode currents of modulator valve and of the modulated stage, and under those conditions have sufficient inductance to effectively couple the audio speech signals. If a choke having an inductance of at least ten Henries under operating conditions is used, good results should be obtained. The usual "smoothing choke" for power pack use, rated at say 15 Henries at 100 Ma, is quite adequate for small rigs.

As a single modulator tube has to supply all the modulating power, such a system is unlikely to be used for a QRO rig! However, the 6L6 is rated at 11 watts maximum output, so that ideally a final stage running at 22 watts could be fully modulated. Practically one can modulate quite effectively, although 100 per cent. modulation level will not be attained with this simple system. In this connection, there is an important difference between modulating a crystal oscillator stage, and modulating a power amplifier stage. If a crystal oscillator is used, it will be found that

the aerial loading must not be too great. This is because with heavy loading the oscillator stops oscillating when the anode voltage is lowered appreciably. Thus on the negative modulating swings the RF output may cease abruptly for an appreciable period during modulation. This results in distortion and "splatter." The cure is to reduce the aerial loading until a good depth of modulation can be achieved. While an oscilloscope is ideal for adjustment, a small neon lamp or flash-lamp bulb coupled to the oscillator will reveal the optimum adjustment quite clearly. Under optimum loading, the glow in the bulb will brighten appreciably on speech peaks. If loading and oscillator tuning are incorrect, the light may actually decrease with the speech peaks, while with very bad adjustment the lamp may be completely extinguished as soon as speech is applied. With choke modulators applied to a power amplifier stage, aerial loading is less critical, and providing adequate RF drive is supplied to the PA valve, good "upward" modulation should be obtained.

In the case of a power amplifier, we are not limited by the inability of the RF stage to be swung down in a negative direction as we are with a loaded crystal oscillator stage. The limit in this case is set by the modulator valve. An ordinary class A amplifier valve used as a
(Contd. on p. 40)

THE DESIGN OF MAINS TRANSFORMERS

Part 5.

by W. E. THOMPSON

The Auto-Transformer

So far we have considered only transformers with separate windings. It is now proposed to deal with the auto-transformer. It must be remembered, however, that whereas the double-wound transformer gives complete isolation from the supply mains, the auto-transformer will have direct metallic connection with them. It depends upon the mode of operation whether this is a disadvantage, but where such a transformer is connected directly into radio apparatus it will be necessary to ensure that neither the aerial nor the earth connection can become live. The usual isolating capacitors should be provided as a matter of course.

An auto-transformer can be either step-up or step-down; whichever type is used will result in a saving in wire for the coils and a decreased volt-amp. rating. Consider Fig. 7, which shows a step-down ratio. The mains input is applied to the whole winding, and the output is taken from the tapped-off portion of this winding as shown. At any instant, the primary and secondary ampere-turns must be equal and opposite (neglecting losses in the windings, etc.), and the current will be inversely proportional to the voltage ratio. In the diagram, the secondary voltage is 200V. and the current 100 mA, the primary being connected to 240V. mains. The primary current is therefore $\frac{200}{240} \times 100 = 83.3$ mA. The

primary and secondary currents will be in opposition in the common portion of the winding A-B, so the net value is $100 - 83.3 = 16.7$ mA. This part of the winding can therefore be designed on this lower rating, with a consequent saving of copper and winding space.

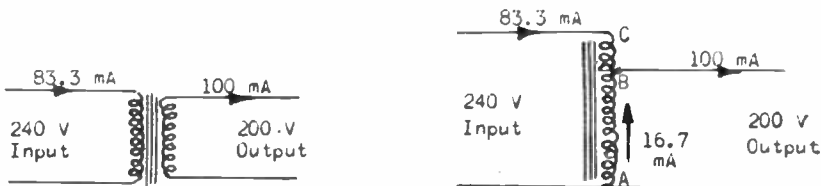

Fig. 7. Step-down Auto-transformer compared with double-wound transformer of same rating.

The remaining part of the winding, B-C, referred to as the series winding, must carry the full input current of 83.3 mA. It will be seen that compared with the double-wound transformer, this arrangement of windings practically eliminates the need for a separate secondary capable of carrying the full output current.

In the case of a double-wound transformer designed for the ratings being considered, assuming eight turns per volt and a wire size based on 2,000 amps. per sq. in., the primary would need 1920 turns of 36 SWG and the secondary 1600 turns of 35 SWG. The auto-transformer for the same output will require 1600 turns of 43 SWG for the common winding and 320 turns of 36 SWG for the series winding. It is obvious, by comparing the total turns and wire sizes, that there is a considerable saving in the auto-transformer.

Turning now to the step-up auto-transformer, Fig. 8, the design considerations are somewhat similar. Here, the mains input is 200V applied to the tapped portion of the winding, the secondary being the whole winding and delivering 240V at 100 mA. The primary current is therefore $\frac{240}{200} \times 100 =$

120 mA. The common winding thus carries only 20 mA and the series winding provides the additional 40V at 100 mA. Using the same design figures as previously, a double-wound transformer would need 1600 turns of 34 SWG for the primary and 1920 turns of 35 SWG for the secondary; an auto-transformer for the same rating would require 1600 turns of 43 SWG for the common winding and 320

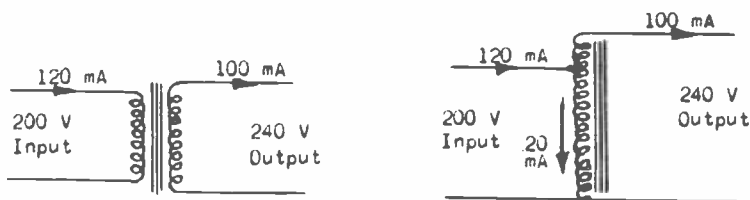

Fig. 8. Step-up Auto-transformer compared with double-wound transformer of same rating.

turns of 35 SWG for the series winding. Again, the saving is clearly indicated. It is of interest to note here that the main difference between this step-up design and the step-down type dealt with in the previous paragraph, is the wire size for the 320 turn winding. If, therefore, the larger size wire is used, the transformer could be used as either step-up or step-down merely by changing the input and output leads.

Both these examples show considerable saving simply because the ratio of input to output is nearly unity. If we consider the case where this ratio is much larger, we shall see that the auto-transformer cannot offer much advantage, and to use a common-place type of transformer for the example let us select a heater transformer delivering 6.3V at 4.0 A, and connected to 230V mains. Ignoring the losses to simplify matters, the secondary load is 25.2 W, so the primary current is 25.2

— = 110 mA. A double-wound transformer 230

for this rating would require about eight turns per volt, so the primary would consist of 1840 turns of 35 SWG and the secondary would have some 50 turns of 17 SWG. Referring now to Fig. 9, which shows the equivalent auto-transformer arrangement, we see that the common winding has still to carry 3.89 A (4.0—0.11 A), so the wire size cannot be reduced, nor can the number of turns be altered. The series winding will still have to carry 110 mA but the number of turns now becomes 1840—50=1790, still using 35 SWG. The only saving achieved is 50 turns less on the primary, which is comparatively small, so there is little advantage in adopting the auto-transformer winding.

From this we can conclude that the auto-transformer is at its best when the turns ratio is a small number; actually it begins to lose its advantages when the turns ratio exceeds 2 : 1 for step-down or 1 : 2 for step-up. At this point we can take note of a unique

feature of the auto-transformer when the ratio is 2 : 1 or 1 : 2. Suppose we have a step-up from 110V input, to deliver 220V 200 mA output. The input voltage being half the output voltage, the input current is obviously twice the output current, i.e. 400 mA. The common winding will therefore carry 400—200=200 mA, and the series winding will also carry 200 mA. The winding thus resolves into a centre-tapped coil, the wire size being the same throughout, and rated to carry only the secondary current. Similarly, for stepdown, say 220V input to 110V 200 mA output, primary current is half the output current, that is, 100 mA. The common winding carries half the output current, (100 mA in this case) and the series winding the same, so once more the winding is a centre-tapped coil using the same wire size throughout, but note that the wire needs to be no thicker than to carry half the output current. And notice particularly what has happened to the windings—with the step-up transformer we have lost the primary entirely and need only the secondary with a centre-tap; in the case of the step-down ratio we discard the secondary and require only a centre-tapped primary. Knowledge of this peculiarity greatly simplifies the design of an auto-transformer for certain American equipment. The standard mains voltage in America being 117V, a 2 : 1 step-down auto-transformer on British mains would cater for voltage ranging from 220 to 250V.

When it comes to calculating what size stampings to use, we need to handle the auto-transformer a little differently to the double-wound type discussed earlier in the article. In order to appreciate this better it is necessary to visualize the working of the auto-transformer in another way. Take the case of the step-up type shown in Fig. 8. If we regard the common winding as a primary and the series winding as a secondary of an equivalent double-wound transformer, we see that the rating of the series winding is 40V at

100 mA, or 4.0 W. (The rating of the common winding is also 4.0 W, since 200V at 20 mA is 4.0 W.) This transformer, then can be based on a volt-amp. rating of 4.0 W only, whereas the double-wound type for the same output would have a design figure of 240 V at 100 mA, which is 24 W. It looks too good to be true, so before we make a mad rush to re-wind all our double-wound transformers and make them auto-transformers in the fond hope that electricity consumption will thereby be considerably reduced, we had better point out that it wouldn't make the slightest difference so far as the Supply Co's. meter is concerned if we did so! The reason, of course, is that the major part of the load is drawn directly from the mains, and the auto-transformer merely supplies the "boost." In this case, of the 24 W output, 20 W will be drawn from the mains directly and the remaining 4.0 W obtained by transformation. The total is therefore still 24 W, but the transformer is concerned with only 4.0 W of this.

The deciding factor in auto-transformer design is the winding with the higher volt-amp. rating. The calculations used for the windings of a double-wound transformer are applied to this single winding, and core size and turns per volt then derived from them. As a clearer insight into the method can be given by means of examples rather than by written explanation, I will give the essential data for two transformers, each designed for the same output, one being double-wound and the other an auto-transformer. Let us suppose we need an output of 280 V at 70 mA from a half-wave rectifier, the mains input being 210V. The design for a double-wound transformer would proceed as follows:—

Correction factor for half-wave rectifier is 2.46, so output is $280 \times 70 \times 2.46 = 48.2 \text{ W}$.

The secondary must therefore carry $\frac{48.2 \times 1000}{280} = 172 \text{ mA}$. Assuming 85% efficiency, the

primary load is $\frac{48.2 \times 100}{85} = 56.7 \text{ W}$, and the

primary current $\frac{56.7 \times 1000}{210} = 270 \text{ mA}$. The

core area will be $0.16 \sqrt{56.7} = 1.21 \text{ sq. in.}$, and this could conveniently be a $1\frac{1}{4}$ in. stack of 1 in. wide stampings. The turns per volt

will be $\frac{6}{1.21} = 5$, so the primary turns will be

$210 \times 5 = 1050$, and the secondary turns $280 \times 5 = 1400$. From the wire tables the wire sizes

(at 2000 amps. per sq. in.) are found to be 29 SWG for the primary and 32 SWG for the secondary. Using enamelled wire, a rough estimation of the space occupied by the wire

alone will be, primary $\frac{1050}{63 \times 63} = 0.27 \text{ sq. in.}$,

secondary $\frac{1400}{77 \times 77} = 0.24 \text{ sq. in.}$ The total is

0.51 sq. in., so the required winding window area will be less than 1.0 sq. in. From this information the type of stamping can be decided upon, and the remainder of the design can proceed on normal lines.

The design for the auto-transformer would be dealt with in this way: The output conditions are the same, so the "secondary" must deliver 48.2 W, the current being 172 mA. Assuming 85% efficiency, the "primary" load is 56.7 W and the current 270 mA as before. Referring to Fig. 8 and inserting these values, we see that the series winding needs to develop 70 V (i.e., the difference between "primary" and "secondary" volts) at 172 mA; the volt-

amp. rating is therefore $\frac{70 \times 172}{1000} = 12 \text{ W}$. The

common winding will carry $270 - 172 = 98 \text{ mA}$, and as the applied voltage is 210V the voltage-

amp. rating is $\frac{210 \times 98}{1000} = 20.6 \text{ W}$. This being

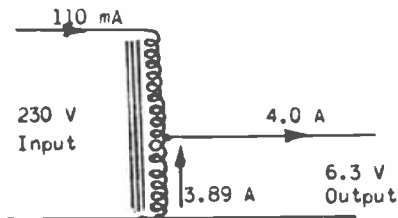
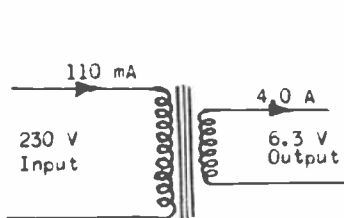

Fig.9. Heater Transformers, double-wound and auto-transformer.

THE RADIO AMATEUR

	Double-wound transformer		Auto-transformer	
	Primary	Secondary	Common	Series
Winding				
Volts	210	280	210	70
Milliamps	270	172	98	172
Watts	56.7	48.2	20.6	12
Turns/volt	5	5	8.2	8.2
Turns	1050	1400	1722	574
Wire size	29	32	35	32
Winding area	0.27	0.24	0.17	0.1
Core area	1.21		0.73	
Window area	1.0		0.5	

the winding with the higher rating, the core size is based upon it, and works out to $0.16 \sqrt{20.6} = 0.73$ sq. in. The core could therefore be a 1 in. stack of $\frac{1}{4}$ in. wide stampings. (Note that the core area is only half that required for the doublewound transformer.) The turns

per volt will be $\frac{6}{0.73} = 8.2$, so the turns for the

series winding will be $70 \times 8.2 = 574$, and for the common winding $210 \times 8.2 = 1722$. From the wire tables we find wire sizes to be, series 32 SWG, common 35 SWG. For enamelled wire, space occupied by wire alone is roughly,

series winding $\frac{574}{77 \times 77} = 0.1$ sq. in., common

winding $\frac{1722}{101 \times 101} = 0.17$ sq. in., making a total

of 0.27 sq. in., so the area of the required winding window need not be more than about 0.5 sq. in. The design now proceeds as for double-wound transformer. The table below collects the above information, the more readily to compare the two types.

The smaller wire size for the common winding takes up less space despite the greater number of turns, and fewer turns on the series winding effect a further saving; the total amount of iron in the core is less so the auto-transformer will be a smaller component with a lower iron loss, which will tend to raise the efficiency slightly. Comparatively, the common winding will have a higher copper loss than its equivalent primary, so this will tend to cancel out the reduced iron loss and result in an efficiency somewhat similar for both types of transformer. The over-riding difference is the 20.6 W for the common winding compared with the 56.7 W for an equivalent primary winding. This saving is not so marked as was seen in the theoretical considerations, for the simple reason that we then assumed a resistive load and no losses, but in the typical designs just worked out we have taken into account the correction factor for a half-wave rectifier, and made due allowance for trans-

former losses. Readers might like to follow on from the foregoing reasoning, working out the calculations in full as they proceed, for in this way a better understanding is obtained than would be possible by prolonged reading. For "further education" the remainder of the designs could be worked out, so that the true occupancy of the windings, the corrections for copper losses, iron loss, and the overall efficiency, etc., can be seen. Some time devoted to such practice work will soon reveal, as was declared earlier in the article, that transformer design is not quite the difficult and frightening process so many people believe it to be. It boils down to simple arithmetic—nothing more.

WORLD RADIO HANDBOOK

Seventh Edition, 1953.

Price 8/6d.

New Edition—just published. Revised and enlarged
—contains all information covering the world's broad-
casting stations.

Compiled from authoritative data, **WORLD RADIO HANDBOOK** is an invaluable "Who's Who" and a ready-made log book for all in any way interested in Broadcast station listening on a world scale. The detail given is designed to facilitate easy identification of Broadcast stations, covering announcement procedure, interval signals, wavelength, personnel and station addresses and containing information about Television stations from all over the world.

WORLD RADIO HANDBOOK is recommended by such authorities as the United Nations Organisation, International Radio Union, and the United Nations Educational, Scientific and Cultural Organisation.

In the new edition, the United Nations publish the following message about **WORLD RADIO HANDBOOK** :

"To build a lasting peace it is essential to use every means of furthering understanding. The special contribution broadcasters and telecasters can make is by sending through the air, over all frontiers, news and pictures of what their peoples are doing and thinking and of how their work and their life fit into the story of man's struggle to master his environment and himself.

WORLD RADIO HANDBOOK brings together all the information needed by broadcasters and radio listeners desirous of following programmes in any other country. We find it indispensable ourselves and cordially commend it to others." Peter Aylen, Director United Nations Radio Division.

“TECHNICAL AWARD”

DOUBLE SUPERHET

by CYRIL R. GREENLAND, G4HD

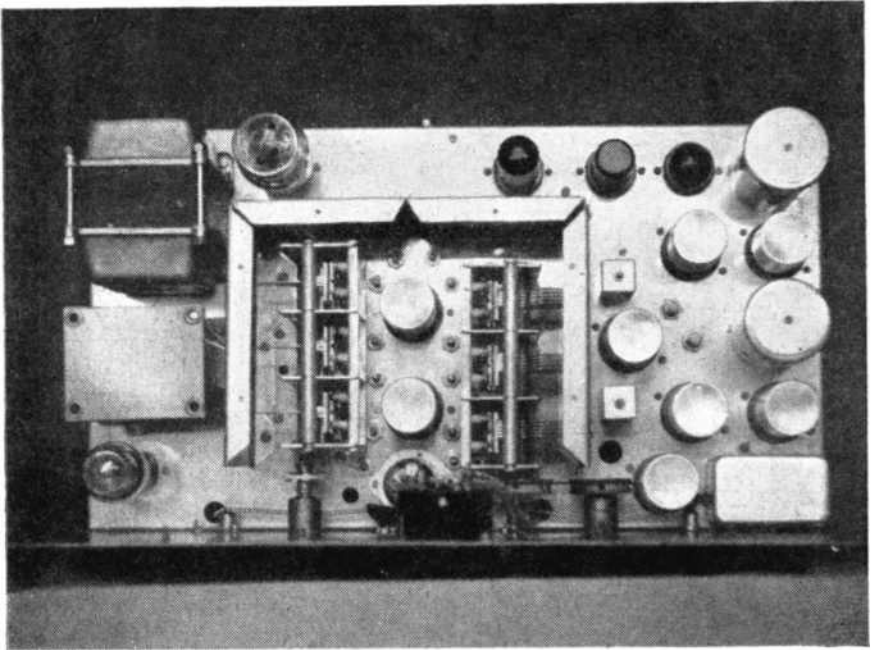

*We have very great pleasure in presenting herewith, the winning entry in our
Technical Award Contest.*

When transmitting licences were re-issued after the war, the receiver then in use by the writer was an 8-valve superhet of normal design, and although this gave a good account of itself, it was felt that in view of the increasing activity on the amateur bands and difficulties with second channel interference on 10 metres and occasionally on 20, that a new receiver was called for.

Prices of commercial models being prohibitive, it was decided to undertake the construction of a home-built set, and a considerable time was spent working out the theoretical diagram. A double superhet was considered essential in order to overcome the second channel trouble mentioned, and in order to keep down the cost, surplus valves and com-

ponents were used as far as possible. The following additional features were also incorporated in the design:—

1. An efficient noise limiter.
2. Variable selectivity.
3. Separate band-set control, and band-spread covering 10 to 160 metres with switched coils.
4. A crystal controlled oscillator for the second mixer stage, which can if necessary be used as a calibrator.
5. Stabilised HT supply for the oscillators.
6. Sensitive S-meter.
7. Power output socket for supplying converters, etc.

All the valves in the receiver are of the single ended type, and there are 8—EF50's

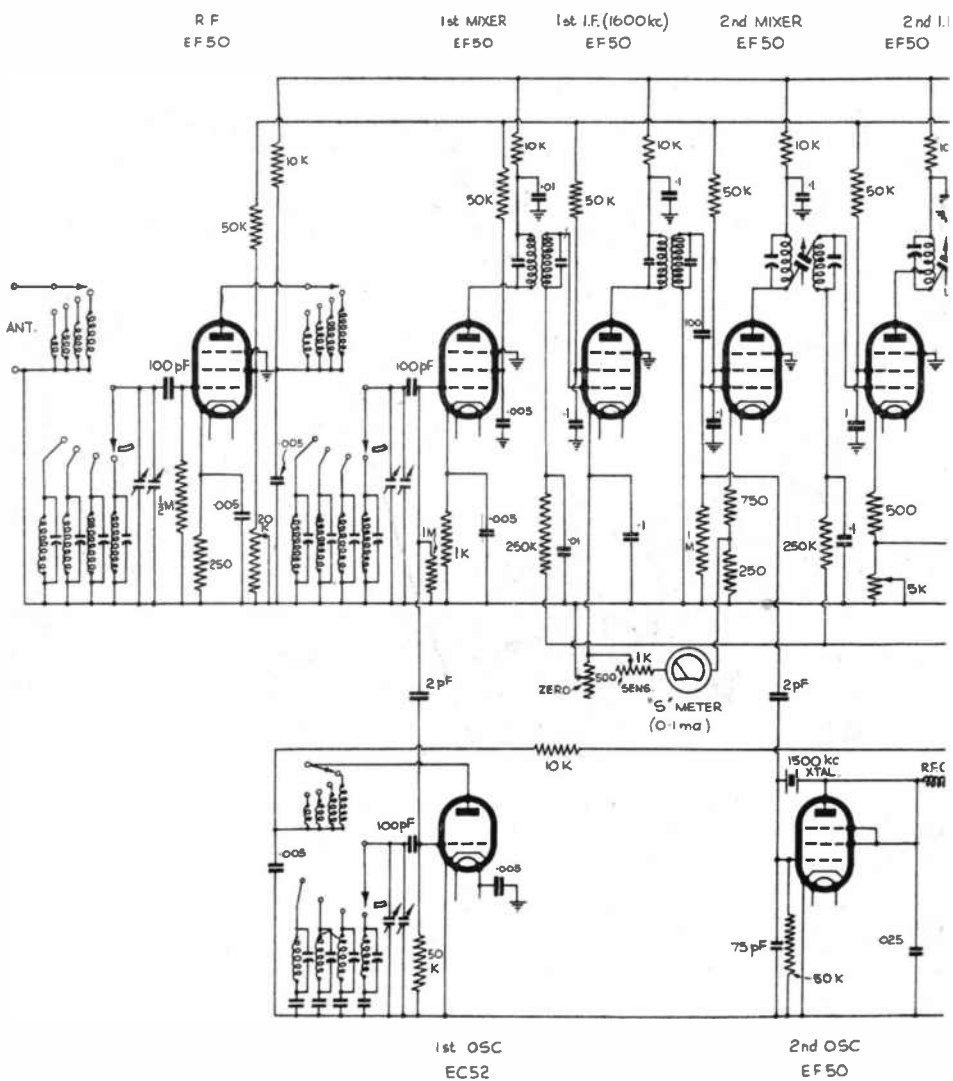

Circuit of the "Double Superhet for the Ama

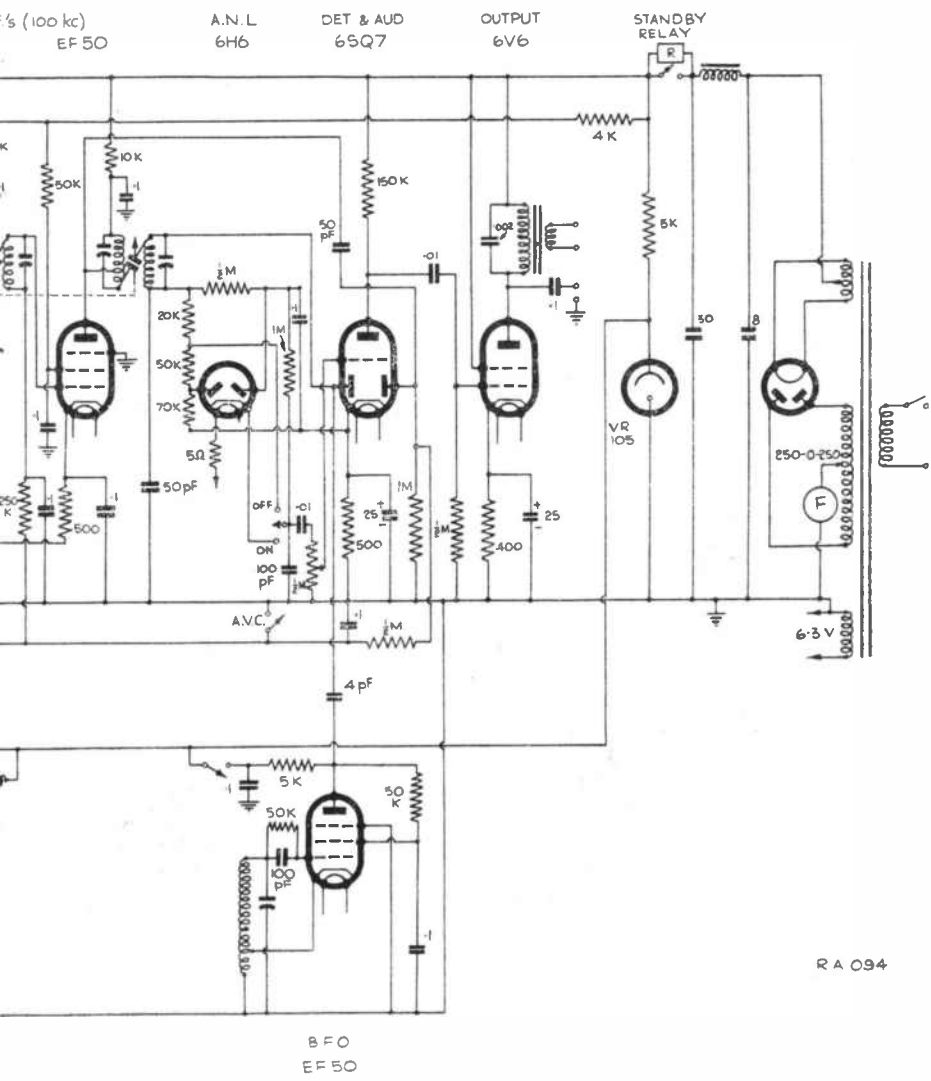

teur," described by C. R. Greenland G4HD.

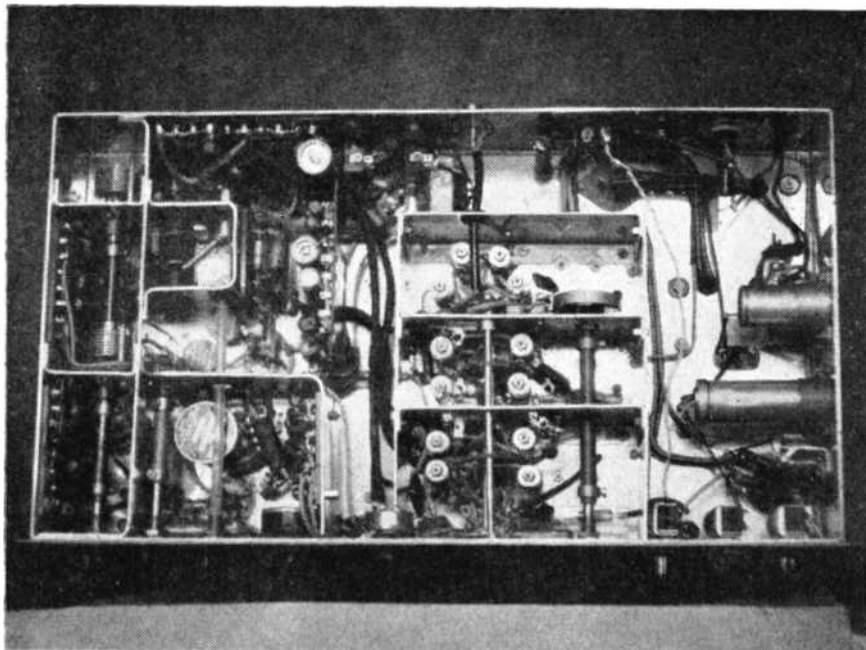

Under chassis view of the Double Superhet.

(some connected as triodes), 6H6, 6SQ7, 6V6 output, VR105 stabiliser, and a standard rectifier. The coils used were Denco chassis mounting type, and a 2-pole four way three wafer Yaxley type switch was chosen with a follow up earthing contact which progressively shorts out the LF coils as the switch is turned to the higher frequency bands. A ceramic switch was not available at the time, but would be an advantage. Before the coils were mounted, concentric type trimmers were attached to the end of each by pressing the tags on each side into the coil former with a hot soldering iron, and the trimmers connected across the main winding. The cores are of course adjustable from the top of the chassis.

In general, most of the condensers and resistors for each stage are mounted on separate tag boards, which were inter-connected as far as possible before being placed in position, in order to simplify the final wiring. The chassis and screens are of aluminium, the chassis measuring 18 in. by 9 in. by 3 in. and the panel 19 in. by 10 in. The receiver is housed in a steel cabinet enamelled grey; the tuning dials are Eddystone full vision type 598 and are illuminated from the rear.

The two 3-gang tuning condensers are also from the surplus market and were originally .0003 capacity. Vanes were removed to bring the capacity of the band-set condenser to approximately 140 pf. Actually there are four fixed and five moving vanes on the band-set condenser and one fixed and one moving on the band-spread. The 10 meter band covers about three-quarters of the band-spread dial, which is also calibrated for 15, 20 and 40. The 80 and 160 bands are covered by the band-set dial.

RF Stage

An EF54 was first tried in the RF stage, and although this gave excellent results on 10 meters, trouble was experienced on the lower frequency bands with cross-modulation from strong broadcast signals, no doubt due to the fact that this valve does not have vari-mu characteristics. An EF50 is now in use in this stage. Note the position of the RF gain control, which brings the screen voltage to zero in the minimum position. The usual position in the cathode does not give sufficient control. This stage is not AVC controlled.

The .0005 by-pass and decoupling condensers in this and the following two stages are mica type.

COIL DATA

Range	Coverage	Denco Range No.	Value of padder condenser.
1	1.7— 2.3 Mc/s.	3'	.0003
2	3.4— 7.4 "	3	.0003
3	8.1—15.5 "	4	.001
4	15.5—30 "	5	.002

* Note that Denco range 3 coils are used for top band with additional .0002 trimmers in the R.F. and mixer stages, and .0001 in the oscillator.

First Frequency Changer Stage

This consists of an EF50 mixer and EC52 oscillator with grid injection. No actual coupling condenser is used for the latter, although a 2 pf value is shown in the circuit diagram, the position of the insulated lead lying close to the grid pin of the mixer giving sufficient injection. It was found necessary to remove three turns from the oscillator "tickler" winding on the highest frequency range to prevent squegging.

First IF

The first IF frequency is 1600 kcs using Wearite iron-cored transformers and a further EF50.

Second Frequency Changer Stage

Two more EF50's are used here, one being triode connected in a Pierce crystal oscillator circuit. The crystal frequency is 1500 kcs and it was originally intended to take an additional output from it to a probe in the

RF stage to give marker points 1500 kcs apart throughout the bands. This arrangement works quite well, although it is not in use at the moment as a Class D wavemeter is available. Of course, if the marker points are not needed, an exact crystal frequency is unnecessary, in fact a crystal in the 1.7 Mcs band would also give a difference frequency of approximately 100 kcs for the following IF stages.

Second IF Stages

These again use EF50's with three "Ferrocart" 110 kcs transformers salvaged from the junk box. These have adjustable mica coupling condensers between the primary and secondary windings, and in the case of two of the transformers, these have been replaced by small air-spaced trimmers, ganged together and brought out to a front panel control, giving variable selectivity.

(contd. on p. 40)

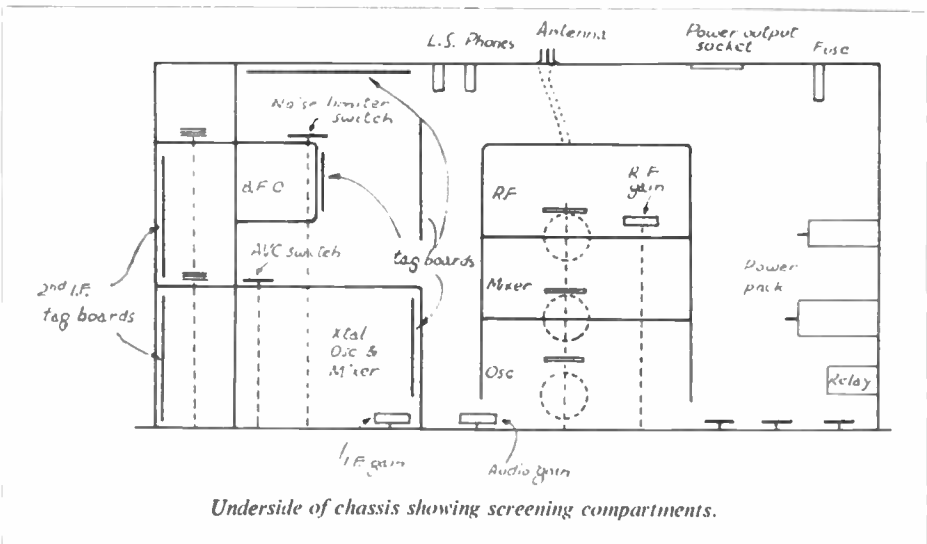

Underside of chassis showing screening compartments.

BROADCAST BANDS REVIEW

by JACK FAIRS

All Times G.M.T.
"Nf"—New Frequency.

Most readers, and especially contributors to these notes, will, no doubt, realise that every month we receive far more reports than can, due to space limitations, be published—enough, in fact, to fill about half this magazine. A great deal of "pruning" is, therefore, essential, preference being given to the items of greatest Dx interest. Our ideal of including "something from everybody" is becoming increasingly difficult to uphold, and to avoid monotonous repetition of items concerning powerful stations on *regular frequencies* and *regular schedules*, more severe "cutting" is necessary.

Such stations as Ankara, Luxembourg, Rome, etc., are listed every month on their allotted channels by many readers. Well, of course, everyone can hear these, as soon as the Rx is switched on! Changes of frequency are another matter, and are always "news," but in order to give more space to items of greater interest and "Dx-value," how about searching for the weaker signals, and leaving the 100-kilowatt-ers for the family's entertainment?

EUROPE

Germany. All German networks are due, commencing December 25th, to inaugurate a general overseas service. The frequencies allocated to Nordwestdeutscher Rundfunk, Hamburg, will be used, together with the NWDR transmitters at Norden-Osterloog, near Emden. Two new 20 kW Tx's will be placed in service, one being due to test before the above date, and the second is expected to be on the air during 1953. ("Sweden Calling Dx-ers.")

Monaco. "Radio Monte Carlo" is again using 7,350 kcs and is heard at good strength in Finland by Kalevi Ant-Wuorinen of Helsinki, at 1600-2230. This frequency was last used in 1948, and has replaced 9785 kcs; is also reported by Roy Patrick and Sidney Pearce. Robert Mercier, of Juvisy-sur-Orge, France, sends along a fine list of Dx he has heard on his new Eddystone 680X receiver, and reports Monte Carlo on 7350 kcs, after a short spell on 7370. They were noted once on 7368, and later on 7345 kcs. (Scribe.)

Eire. "Radio Eireann" has been audible on the East Coast of the U.S.A. on a varying 15120 kcs, with daily news at 2110-2130; signals were weak and QRM'd. ("Radio and Television News.")

Portugal. "Radio Renascenca," Lisbon, 6154 kcs; Q5 S8 with QRM at 2100. (Bill Griffith, Ashtead.)

Greenland. A station announcing as "Grönlands Radio," (and no doubt OXI Godthaab), is reported on 9310 kcs at 2210-2347, and as late as 0002 on Sundays. ("Australian

Dx-ers Calling.") This is not an entirely new frequency, being logged here a few times twelve months ago around 2300, and on another occasion at 1530. (Scribe.)

Spain. The small Spanish stations are still moving around the 41-metre band, and the general tendency now seems to be the occupation of frequencies just below 7 mcs. Latest observations show "Radio Alerta," Valencia, opening at 1900 on around 6930 kcs (Robert Mercier), and closing at 2304 on 6940 kcs (Scribe.) "Radio Juventud de Sabadell," Barcelona, has been reported on 7312 and again on 7345 kcs.

"Radio Nacional de Espana en Malaga" has moved from 7022 kcs, and noted on 6955 at 1845 (Mercier); another report quotes 6940 kcs, but measured here on 6950 at 2300 to close at 2330 (Scribe.) "Radio Juventud de Almeria," Almeria, was found just below Malga, on 6945 kcs at the same time, also closing at 2330.

Denmark. Call-letters of the Danish Short-Wave Service have been changed to OZF3 6060 kcs (Nf), OZF4 7260 kcs, OZF5 9520 kcs, OZF8 15180 kcs, and OZF9 15320 kcs. (*World Radio Handbook*.)

AFRICA

Northern Rhodesia. From Lusaka we have received our verification for reception of the broadcasts on 4826 kcs. We duly thank Mr. J. M. Reeves, Broadcasting Engineer, who tells us that the present schedule is: 1200-1730 on 7220 kcs, 1700-1900 on 3275 kcs, and 1200-1900 on 4826 kcs. All broadcasts from Lusaka are directed to the African population of the three Central African territories of Northern and Southern Rhodesia and Nyasaland, while programmes for European listeners are transmitted from Salisbury in Southern Rhodesia. We quote further: "We have plans for extending considerably our broadcasting station in 1953, when a new transmitting station and new studios are to be erected. The ultimate aim as at present foreseen, is to have two simultaneous transmissions in African vernaculars and simple English, and for the hours to be further extended."

G. O. D. Harris, of Shortlands, Kent, also sends along the above schedule; Robert Mercier hears the 7220 kcs outlet in the clear before 1700, when Paris opens on the frequency.

Angola. The "New Zealand DX Times" lists "Radio Diamang" at Dundo on the 4770 kcs channel, giving the call as CR6R1 and the schedule of 1800-1930; the other outlet in use at present is CR6RG, 7070 kcs, and the power is 100 watts.

Madagascar. "Radio Tananarive" on

9515 kcs is heard with fair signals in New Zealand around 1730 with a programme in French, reports Jan Hardwick, of Thames Line. Robert Mercier also mentions this frequency around 1800, but the Malgache-language transmissions on 7375 kcs are usually better signals, and have a varying sign-off time: 1700, 1705, 1730 or 1735.

Tangier. "Radio Africa" has returned to the original 7126 kcs. channel, as too much QRM was experienced on 7195. (Sidney Pearce, Radio-Sweden and Scribe.) Pan-American Radio is now on 7302 kcs; the best time to log this one is 1415 to close at 1515, as the evening broadcasts are hardly perceptible for QRM from Athens. (Mercier.)

Nigeria. Another Regional station of the Nigerian Broadcasting Service is located at Emugu, and has an output of 250 watts on 7083 kcs. It is reported heard in parallel with Lagos (9655 kcs.) at 1700-2200, even though official schedules list sign-off at 2000. The other Regional station at Kaduna, mentioned in last month's "Review," is now quoted on 4925 kcs. (Radio-Australia.)

Senegal (French West Africa). "Dakar-Africa" was logged on about 9560 kcs, closing at 2230 with French announcements (Scribe); Robert Mercier reports them on 9562 kcs (announced) at the same time. News in French is read at 2200.

NEAR EAST

Kuwait. As many readers will already know, the mystery of the Arabic station on 5000 kcs is, at last, solved. A listener located in Israel, via Radio-Sweden, has announced its identity, but W. D. N. Berry, a member of the ISWL Signal Survey Section, has been visiting Kuwait, and before he left England we requested him to confirm our personal "hunch" that the station may actually be located in, or near, that town. This he did, adding: "... the station nearly blows the set up—I have to take the aerial out!" He air-mailed the following details within three days of his arrival.

"Radio Kuwait," 5000 kcs. Schedule approx. 0830-1000 and 1600-1905. Programmes consist of native music and news (?) broadcasts, the language used being exclusively Arabic (Iraqi dialect). We quote in full W.B.'s description of the closing announcements: "1855 Arabic music, then cease; tapping of microphone and announcement; more music to 1905 (approx.), when the male announcer continues . . . 'Mohammed Ami . . . Samd . . . Mohammed Aduha . . . Huna Kuwait' (more music) . . . 'Mahattat Kuwaitia . . . Huna Kuwait.' Then sudden close-down."

Many thanks to our reporter for the above confirmation. (The contest for the identity of this station—October *Review*—is hereby declared void !)

Transjordan. The Hashemite Jordan Broad-

casting Service at Ramallah has abandoned the broadcasts on Short-Wave. (WRH).

Israel. "Kol Zion Lagolah" has been reported using 15155 kcs (Nf) on Sundays only at 1300-1400, in English (1300-1315) and Afrikaans; is announced as being directed to the people of South Africa. (RTN). Another report gives 15550 kcs at 1130-1230.

ASIA

India. The European Service of "All India Radio," New Delhi, now broadcasts the English programmes one hour later, i.e., 1945-2045. Frequencies used are 7120, 9565, and 11780 kcs, though also heard at the same time on 7275 and near 4875 kcs. The French transmissions open at 1945, and are still on 5965 and 7125 kcs, but also spotted near 4940 kcs. (Sidney Pearce, Berkhamsted).

Pakistan. "Radio Pakistan," Karachi, has replaced 9484 kcs by 6235 (7010 kcs remaining in parallel) for the English programmes at 1930-2100 daily. Regular broadcasts to Indonesia at 1130-1215 have now commenced on 15270 and 17835 kcs; this programme includes a talk in English at 1145. (Pearce and NZ DX Times).

Portuguese India. The current schedule of "Radio Goa" is 0200-1730 on 6025 and 9610 kcs, plus experimental transmissions on 3425 kcs (Nf). (WRH).

Vietnam. "The Voice of Vietnam," Saigon, is reported by the NZ DX Times on 4960 kcs (Nf) with News in English at 1430, recorded music, and sign-off at 1500; other frequencies given are 835, 7285 and 9610 kcs. (Should this be 9620?—Scribe). Robert Mercier logged this station on 9620 kcs, with News in French at 0001, records at 0015 and Vietnamese at 0030; signals were Q2-3 S5-6 with QRM from TIDCR. Robert also lists "Radio France-Asie," Saigon, with the English/French musical programme around 1540, News in French at 1600 and close at 1615. BBC Station GVX on 11930 kcs causes bad QRM, and the frequency is about 11927 kcs. (Last report gave 11935—Scribe).

From Japan (via NZ DX Times) comes news of "Radio Laos." Laos, on 7215 kcs, heard with News in French at 1300-1315, and "Radio Hirondelle" at Hanoi on 7408 kcs, heard at 0400-0630, and 1030-1500 (or to 1600 on occasions).

Indonesia. "The Voice of Indonesia" at Djakarta has been heard testing in English on 11935 kcs (Nf) at 1130-1225, according to "Sweden Calling Dx-ers." The 9865 kcs signals were heard again very recently, still closing at 1530 with clock chimes for 11 p.m. (Scribe). The previous channel for this one was 9990 kcs, and it is believed to be the new 50 kW transmitter. (NZ DX Times).

Japan. The International Broadcasting Service of NHK is now on the air as follows: 0500-0600 to North America on JOB4 (11705)

and JOA6 (15135); 1100-1200 to North China, and 1200-1300 to Central China on JOB2 (7180) and JOA3 (9675); 1400-1500 to Philippines/Indonesia, and 1530-1630 to India/Pakistan on JOA3 (9675) and JOB4 (11705 kcs). This latest schedule comes from Ian Hardwick.

PACIFIC

Dutch New Guinea. Tony Allmey of Worthing calmly tells us he has received a QSL from Hollandia ("Radio Omroep Nieuw Guinea") on 7135 kcs, and he heard them around 1115 with weak signals and poor modulation. Yes, this one really is Dx!—especially as the Rx used is an unpretentious 4-valve job from "Radio Rentals!" Nice work, OM.

Hawaii. WVVH Maui have verified a report by the above reader (using the same Rx), for reception on 15000 kcs. The full QRA, by the way, is: National Bureau of Standards, Radio Propagation Field Station WVVH, Technical Operations, P.O. Box 901, Puunene, Maui, Hawaii Islands.

Philippines. A new outlet of "The Call of the Orient," (Far East Broadcasting Company), Manila, has been found by Sidney Pearce near 17805 kcs from around 0915 with a religious programme in English; Sidney adds that they are usually "wiped out" by Rome at 0945. Arthur Cushen, Invercargill, New Zealand, lists this new frequency as DZ16, with fine reception at 0800 and later.

Australia. Sidney Pearce summarises his reception of "Radio Australia" as follows. Good signals for British Isles and New Zealand at 0745-0845 over VLB9, 9580 kcs, and in parallel at 0645-0815 over VLA11, 11760 kcs. VLC15, 15320 kcs, is heard well from sign-on at 0828, and again at 1400-1615. VLA11 is now on 11840 kcs, instead of 11810, for the broadcast to U.S.A. and Canada at 1400-1615. The transmission for Europe at 1800-2000 is still over VLC7, 7215 kcs, and VLA11, 11760 kcs; VLC7 closes at 2000, but VLA11 continues for the British Isles, to be joined by VLC15, 15200 kcs, at 2015 and by VLB15, 15160 kcs, at 2030.

Ronald D. Young, Chelmsford, Essex, reports VLA11 on 11760 kcs with a fine Sunday Service at 1815, followed at 1845 with "Magazine of the Week."

NORTH AND CENTRAL AMERICA

United States. Roy Patrick has been pulling in the Medium-Wave Dx again, and lists the following stations, all heard around 2400: WMGM New York, 1050 kcs (which is owned by the M.G.M. Film Company); WTOP Washington, 1500 kcs; and WEMB Porto Rico, 1320 kcs.

Canada. VE9AI Edmonton, Alberta, is noted on 9540 kcs in Indianapolis, USA, by Marvin E. Robbins, Short-Wave Editor of the Universal Radio DX Club. This station has

News in English at 2400, but signals are weak, with QRM from XEFT and Tangier. Robert Mercier has heard a Canadian station on 6070 kcs at 2315-2345, which must surely be the 1 kW CFRX at Toronto; positive identification was difficult for QRM.

Mexico. Marvin Robbins has cleared up the question of "Radio Morelia," Morelia. XEKW is definitely the call for the 6030 kcs outlet, and official government lists show it thus. The confusion with XESF (1300 kcs MW) has arisen due to the layout of their QSL Card—if one reads it vertically, XEKW appears to be on 1300 kcs, and XESF on 6030, but vice versa if read horizontally!

Cuba. COBQ "Loma del Mazo," Havana, 9235 kcs, is on the air at 1300-0500 according to a letter veri received by Ian Hardwick.

El Salvador. Station YSDR Santa Ana has been logged on 4797 kcs with fair signals, though QRM from HJFU Barranquilla a split kc below, and from YVMF Maracaibo on 4800 kcs. The call is "Radio Tropico," and sign-off at 0310. (Marvin E. Robbins). YSG "Radio Victoria," San Salvador, on a varying 11767 kcs, appears to be having Tx trouble, as the frequency varies tremendously from moment to moment and temporarily goes off the air at intervals. (Robbins).

YSAX San Salvador is another new station heard in the USA with very strong signals all through the day on 11950 kcs; it announces as "La Voz Panamericana." (Robbins). Arthur Cushen reports the call on 11950 kcs as YSAXA "La Voz de Panamerica" a five-note chime is used, and sign-off is at 0600 with the "Warsaw Concerto." YSAX appears to be the MW outlet, according to "Radio Australia."

YSC "Radio Mil Veinticinco," San Salvador, is heard in the USA around 0530 on 6075 kcs. (URDXC).

Haiti. Robert Mercier sends us some interesting news about "Radio Haiti" at Port-au-Prince. The station is now using, and announcing, two SW frequencies. 4VRW, after a short stay on 10015 kcs, was later heard on 10070. (Robert wonders if the power of 4VRW has been increased, as he is logging it regularly as early as 1815, which is certainly unusual Dx if the power is still only 300 watts, as listed). The new outlet, 4VSW, has been heard twice on about 6177 kcs, in the clear at 2300-2330. (4VRW is probably Stanley Coppel's unidentified station on 10020 kcs mentioned last month).

SOUTH AMERICA

Brazil. Further news of Brazilian stations has been published by URDXC. "Emissora Continental," Niteroi (State of Rio de Janeiro), is now on the air on 6195 kcs, but no call-letters have been assigned as yet. "Radio Tupi," Rio de Janeiro, is planning to operate the new 100 kW station on 6200 kcs; the call

will not be ZYC7 as this belongs to a MW station in Minas Gerais. The correct location of ZYR59 "A Voz do Sertao" (3335 kcs), mentioned last month, is Presidente Prudente (State of Sao Paulo), while ZYR57 "Radio Cultura" (9745 kcs) is actually in the city of Sao Paulo. Taubate (ZYR61), and Marilia (ZYR62) are both in the State of Sao Paulo. The time station, ZYZ20 "Radio Relogio Federal," Rio de Janeiro, 4905 kcs, is not yet on the air.

Two more new stations are featured by "Sweden Calling Dx-ers" this month. ZRY63 "Radio Emissora de Piratininga" is on 6025 kcs at 0900-0400 with an output of no less than 50 kW; the QRA is Praca do Patriarca 26, Sao Paulo. PRB4 "Radio Clube de Santos" was testing recently on 11855 kcs, and the address for this one is Rua Jose Cabalero 60, Sao Paulo.

Bill Griffith reports hearing ZYR57 (above) on 9745 kcs; on one occasion ORU Brussels was "underneath" them but sometimes the reverse is the case. NZ DX Times lists ZYR57 opening at 0900 with "The Bells of St. Mary's."

Venezuela. The 9510 kcs outlet of "Radio Barquisimeto," Barquisimeto, is now using the new call-sign YVKJ. Robert Mercier, who reports this, is hearing them as early as 1805 some days, until sign-off at 2130 (though subject to heavy QRM from GSB) and he adds that they announce as "La primera emisora comercial en la banda internacional de 31 metros"—("the first broadcaster on the 31-metre band!")

Another Venezuelan station has now appeared on 9 mcs, in the shape of "Radio Popular" at Maracaibo, and heard at 1930 until after 2400. The frequency is 9625 kcs (though announced as 9630), and the other outlets in use, YVMH (1250 kcs MW) and YVMG (4810 kcs), are given, but, as yet, no call-sign for the new one. (Robert Mercier and Scribe).

YVMM "Radio Coro," Coro, has been noted on 4949 kcs (Nf) around 2300 (and later on 4946 kcs), instead of 4910. (Scribe). Arthur Cushen has received an airmail QSL from Sr. Ruden D. Sifontes, Director of YVRA "Radio Monagas," Maturin, on 3490 kcs; this was the first report received from outside America, and the QRA is: "Radio Monagas," Apartado 14, Maturin, Monagas, Venezuela. Roy Patrick lists YVKF "Ondas Populares," Caracas, 4810 kcs, heard regularly with English sponsored programmes at 2300-2330, and News in English at 2345 on weekdays; according to announcements, they hope to increase power very shortly, as well as the English service.

Peru. OAX4H "Radio Mundial," Lima, 6095 kcs: good signals in Australia at 0645.

(URDXC). OAX4C "La Voz del Primar Puerto del Peru," Callao, 6564 kcs, verifies reports by letter signed by Julio Caracas; the QRA is: Saensa Pena 151, Callao. (NZ DX Times).

OAX6E "Radio Continental," Arequipa, is now heard on 6305 kcs at 2245. (Robert Mercier). This must be a move from 6335 kcs—Scribe). OAX4T "Radio Nacional del Peru," Lima, has been noted on the old frequency of 9562 kcs around 2230 until closing abruptly at 2300. (Mercier).

Colombia. HJEF "Radiodifusora de Occidente," Cali, 4765 kcs, has verified Ian Hardwick's report by air mail with a photo-card and an invitation to visit the station! HJCT "Radiodifusora Nacional de Colombia," Bogota, has moved from 6205 kcs to 6183 (Nf), and heard after 2200 with fair signals. (Robert Mercier).

Ecuador. The unidentified station widely reported on 4203 kcs is now reported by Marvin E. Robbins to be HC4AS at Bolivar—is not Cuenca, Ecuador, or Caracas, Venezuela. The power must be fairly high, as it is always S9-plus in Indianapolis, and the call, "La Voz de las Caras," is clearly heard; sign-off is at 0430 weekdays.

LRV "Radio Belgrano," Buenos Aires, is using 9760 instead of 9455 kcs . . . the Forces Station at Salonika, Greece, has been heard in New Zealand on 7100 kcs at 0600 on Sundays . . . Bangkok, Siam, is now using 6240, 7140, 11910 and 15630 kcs (NZ DX Times) . . . "Radio St. Denis," Reunion Isle, has been heard in South Africa on 7168 kcs in French at 1415-1625 . . . Taipeh, Taiwan, heard on 9750 kcs (BEC22?—Scribe) with English for the USA at 1200 (NZ DX Times) . . . BEC26 Tsoying (1.5 kW) on approx. 10060 kcs was Q3 S3-5 with light music to close at 2330 with a single chime (Scribe) . . . "Radio Club de Tenerife," Canary Islands is now on 7295 kcs (Nf) at 2100-2245 (WRH) . . . CE920 "Radio Militar Austral," Punta Arenas was logged once at 0050 with fair signals on about 9195 kcs (Mercier) . . . "Radiodifusora Lobito," Lobito, Angola, has English on Sundays at 1800-1900 on 7106 and 7177 kcs (WRH) . . . HP5J "La Voz de Panama," Panama City on 9607 kcs is sometimes heard well, while Athens is off the air, i.e., before 0045 and after 0205 (Mercier.)

CONCLUSION

And that's all for now. Material for this column should be sent to: J. Fairs, 2a, Durham Road, Redcar, Yorkshire, England, and should arrive before 27th January for inclusion in the March issue. The Editor and your Scribe thank all contributors for their letters and news items appearing in these pages, and Good Dx to you all until next month.

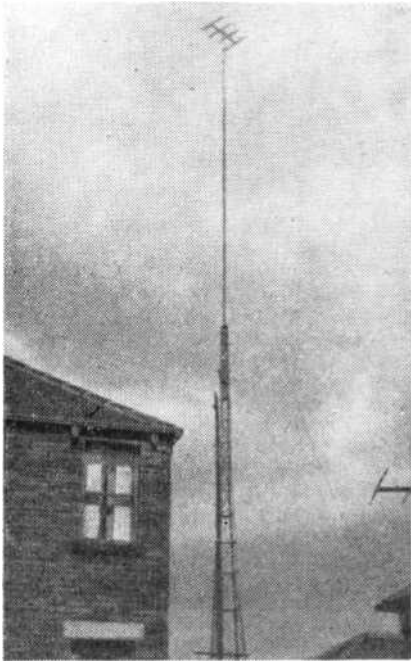

ON THE HIGHER FREQUENCIES

Monthly Notes and News

by

H. E. SMITH, G6UH

*Our photo shows G5YV's beam,
well up in the clouds, at Leeds!*

A very Happy and Successful New Year to All. May we see some good conditions and high activity in 1953.

Talking of activity, where do VHF stations go to in the winter time? Judging by reports and what we *hear* from time to time, there is little doubt that many operators migrate to 1.6 and 3.5 Mcs. For instance, quite recently three VHF operators were heard in a "net" on 3.5 Mcs. All were complaining that activity on 144 was nil, yet they were close enough to each other to operate the "net" on 144! It would appear, therefore, that the very reason for the low activity was the fact that the stations representing that particular area were all operating on 3.5 Mcs. Queer, isn't it? Now a few words about our own activity on the band.

We have been taken to task for not appearing on the band so regularly these days. In spite of the continued heavy business commitments it was decided to make a special point of coming on the band every evening for a ten-day period. This commenced during the first week of November, and your conductor sent out over 20 CQ's between 1845 and 2000 GMT each evening for 10 days. What was the result? On the *fourth* evening we managed our first QSO. This was with G3HZK, distance—1 mile. During the following seven days we had our second and last QSO of the period, G2YB (Reading). The excellent report

we obtained indicated that there was nothing wrong with the Transmitter at our end. The only other signals heard during the period were G2NM (calling us on schedule arranged by G2YB), G8AO/MM, G4DC, G3GBO (we called you four times Don), G3GDR, and several very weak carriers which were not identified. Now did we choose the wrong time for our test or what? We only know that if the same test had been made during the same period of 1951 there would have been perhaps two dozen or more QSO's obtained. Our log book shows this to be so. What is there that can be done to encourage more activity? Several operators wrote to us suggesting a January Contest to liven things up. In the November issue we stated our willingness to stage a Contest this month and asked all in favour to drop us a line. *Three* operators only took the trouble to write, so we decided that most people were against the idea, so we leave it at that.

We have given much thought to this question of VHF activity and it seems to us that something *could* be done.

It is quite evident that the RSGB are not giving sufficient support and encouragement to the VHF man. The Editorial in the Bulletin last October shows that there is also a lack of understanding of the actual operating conditions on VHF. It will be an extremely poor lookout for the VHF man if the 2 metre

band is allowed to go the way of 70 cms, written-off as a dead loss because of the lack of Official interest and encouragement. Sponsoring Contests and awards, running VHF ladders and whatnot is just the sport of the game and these things can be handled by the various Amateur magazines. What is required from the National Society is some leadership, organisation and *policy* for the VHF operator. Look at the recently formed VHF Research Society of Ireland. One man alone, Harry Wilson Ei2W, has rallied the Irish Amateurs to the cause of VHF. Over 100 members are either on the band or building gear, and we are prepared to say that in a short while there will be more activity in Ireland than in the whole of this country.

This is because the VHFRSI has a *policy* and an *aim*.

A counterpart of the VHFRSI could easily be formed in this country and have its own monthly or quarterly Bulletin, thus providing a regular channel through which information could be passed to all members. We are not in any way hinting that we wish to form such a Society. We think it is a job which should be tackled by the RSGB, and we put this up to them as an idea which we are sure would meet with approval from all quarters. But anyone keen enough to start such a Society must be keen enough to *continue* to run it for the benefit of the VHF fraternity *only*. What are our readers views on the subject?

The VHF Newcomer (Mainly the Listener)

Any newcomer starting up on 2 metres at this time of the year must be very patient. The reason that you are unable to hear or work many stations is that we are passing through a period of unprecedented inactivity. As the spring approaches we shall no doubt see a great increase in activity. So please do not give up in disgust as many others have done, take advantage of the lull to improve the converter still further, and make some more adjustments to the aerial in order that everything will be in readiness when the DX does come rolling in again. In response to requests we shall in future devote part of this Beginner section to a VHF Problem Corner. Unfortunately we cannot guarantee to publish diagrams, etc., but when a very interesting case crops up we shall see what we can do about it. No matter how trivial your problem may seem, send it in. It is sure to be of interest to someone else. If you had a problem and solved it, let us know what it was and how you did it. There is an absolute dearth of practical information for the listener and any little tips or hints will be most gratefully received in many quarters.

There seems to be a dearth of VHF listeners these days as well! We have a little circle (a very select one if we may say so) of about four

VHF listeners who regularly contribute to our columns, and judging by what we read elsewhere there seems to be only a round dozen or so in the whole country. Perhaps there are a great many more than this number, and it may be that they never send in reports to any journal. This is a mistake. Listener reports are of great value to the Transmitter, and by sending in lists of calls heard, the listener is doing more of a service to the cause of VHF than perhaps he realises. To those that listen for hours and hours and hear nothing at all, drop us a line just the same, we may be able to help you to put the converter right. We urge *all* VHF listeners to send in reports of all signals heard on the band. (If you don't want to send them to this magazine, send them to another. The main thing is to get the reports in print where they may catch the eye of the interested operator. Remember we do *not* lay any claim to being the *only* champions of the VHF cause in the country). We also ask all VHF listeners in the Western half of the country to keep a good look out for signals from Ireland at the HF end of the band. Many stations over there are now testing equipment and they would all appreciate listener reports. This is where you can be of really good service. If you are not sure of the QTH of any Irish station heard, you may send your report via Mr. H. L. Wilson Ei2W, "The Limes," Plunkett Avenue, Foxrock, Co. Dublin. A short list of Irish station frequencies was given in our last month's issue, and we shall augment this from time to time as the information reaches us.

We are trying to help the listener as much as possible, primarily because we like helping people, and secondly because the RSGB appear to have no room in the Bulletin to devote any space to the interests of the BRS man, which seems to us to be rather odd.

We are sorry that the Newcomer feature this month does not contain any technical gen but we felt that this little discourse for the listener would be of some benefit to those who may have the feeling of being left out in the cold.

So don't forget to drop us a line with your query or report.

Finally here is a potential listener who requires some help.

Gordon Taylor of 362, Huddersfield Road, Battyeford, Mirfield, Yorks., wants to get going on 2 metres and would like some information on modifying the Type 26 unit for the band. Gordon would also like to hear from any VHF Transmitter or Listener, so what about it somebody?

Transmitter Reports and News

In spite of the low general activity we have again received a nice batch of letters for this issue. One particular letter is a pointer to what we can expect from many quarters unless

something is done quickly about the low activity problem. The letter in question comes from G6CW (Nottingham) who was one of the better known operators on the old 5 metre band, and not less well known on 2 metres. John has dismantled his gear and is now QRT due to the general inactivity and lack of interest being shown in VHF operation. This is bad news. When an old timer like G6CW decides to abandon the VHF bands there is clearly something very wrong. However, we do hope that he will be induced to return when conditions look up again. Good luck to you John.

We were pleased indeed to receive a report from G8LN (Plumstead). G8LN has been a Ham for 25 years, ten years as G2AI, and 15 years as G8LN but refutes the suggestion that he is a case hardened Old Timer! "Will" describes his QTH in detail and it would appear that in spite of his being situated some 200 feet above sea level, the presence of Shooters Hill causes some queer effects on signals. Even on the 1.8 Mcs band the effects of the hill are noticeable. If the weather is wet, the absorption effect is greater. In the direction where the left hand top of the hill is 1 mile distant, stations can be worked well, but when the hill tails off at 100 yards from the QTH extreme difficulty is experienced in working stations in this direction. G8LN is actually situated in a small valley and his best directions are France, Kent, Sussex and Essex. G3ANB (Brightlingsea) is always workable but there is usually some QSB across the Thames. The present QRG is 145.600 Mcs with 12 watts to a new transmitter. The design of the transmitter is somewhat unorthodox, with the 24 to 72 Mcs stages mounted under the chassis and completely screened. Everything is mounted on a tinned steel plate which sits on an aluminium box and is bolted down. Thus any modifications can quickly be made by removing the fixing screws. G8LN is looking for contacts on 2 metres, and would like to hear more stations on the band between 19.00 and 22.00 GMT.

(Thanks for your first report to our columns OM, and we look forward to hearing from you again).

From "Range Buster" G3WW (Wimblington, Cambs.) comes the usual breezy report. G3WW says the shack takes an hour or more to warm up and his visits there have been few. Yet we find evidence in his report that he put in a great number of hours on the band during November. On the 13th a QSO was obtained with G3EEL (Peterborough). On the 21st G4DC was again worked, "a rag chew over an optical path" as 4DC put it. (Camberwell to Cambridge is an optical path if one has an RF stage that works as well as G4DC's does. Hi). Sorry WW we should have said *March* not Cambridge! Many other stations were

heard and called over the period November 21st to 30th, and most of the locals were worked. During the bitter cold on the 25th, G3GZM (Worcs.) was worked at 569. On the 30th G8MW was heard working G5NV. G3WW gave him a call when he had finished but could not attract his attention. QTH of G8MW is given in the Call Book as Morecambe, Lancs. (Would G8MW please confirm the QTH if this should catch his eye.) Later in the evening of the 30th, a contact was had with G3DIV (Eastbourne). Other stations heard and/or worked include G3AEX, G6NB, G5UM, G2FNW, G4MW, G2FQP and G3DUP. (Many thanks for the report 'WW, which we note with interest, was again written from home).

Coming down South from Wimblington to the pleasant village of Deuham, Bucks., we come to the report from G3GBO. Don says that November was one of the leanest months he has had for some time. The two factors responsible for this were, firstly Exams., and secondly that the big aerial is still out of commission due to the gales. In order to "keep the old firm in business Don has been using the Field Day beam with its 20-foot mast, and has been able to maintain contact with the locals, and even succeeded in working two new stations in the limited amount of time available. Stations worked over the month include: G2AHP, YB, HDZ, FAB, ANT, G3HBW, HZK, CAT, EYV, GSG, G4DC, AU, MR, CG, GT, G5DS, BC, QL, G6NF, BO, NB, YP. Conditions have been generally poor, and activity low. On several occasions G3GBO has tuned round the band and not heard a single carrier. This occurrence is rarer than it would first appear says Don, and it is seldom that one cannot hear *something* during a careful search of the band. (See also our own experience early in November.) Work has commenced on a super-economical portable rig, making use of battery valves where possible, and it is hoped to put this into use next Summer. (Thanks Don, and may you remain in circulation for another month or two before you start your two years of enforced inactivity!)

Still southwards, to Eastbourne, where our old friend G3DIV and second operator J. E. Harman have been prevented by heavy business pressure from being very active over the past few months. Although G3DIV has worked a great deal of GDX since starting up on 144, there is still a large section of the country which has never been heard or worked. In view of this, a new Transmitting QTH has been chosen, situated on practically the highest point in the town. The site will be tried out as soon as the weather and conditions take a turn for the better. The transmitter remains the same, an 829B final with 110 watts.

Several versions of what is popularly known as the G2IQ converter have been tried out, the present one consisting of a crystal controlled oscillator. The opinion is that a neutralised RF push-pull stage in front of this unit is of no advantage as the signal and noise are amplified in almost the same proportion. However, G3DIV has built another converter to a design by ON4BZ, which at the time of writing has not been fully tested out. (Have a go at the new pre-amp which will appear in next month's issue of this journal!)

More comments from J. E. Harman appear in the listener section. Well, it certainly was nice to hear from the Eastbourne boys again, but we were sorry to hear from G5LK of Reigate that he has suffered a minor disaster. The gales seriously damaged the beam, and due to the weather conditions Les has been unable to organise help to lower the mast. However, G3FOU (who is now on the band) and G3CTY are visiting him in the near future to carry out the repairs. By the time these notes appear G5LK will probably be as active as ever again. Good luck to you Les. Talking of luck, GW2ADZ (Llanymynech) lost his 70 cms beam during a terrific gale early in November. From his description we can picture Bill crawling flat on his stomach, with a torch in his mouth, along the roof of the barn in the pitch darkness with a howling gale blowing, to tie down the pieces in case the whole works blew out of the district. All was saved and the beam has now been repaired.

During the first half of November GW2ADZ was active in the usual manner with good contacts at 170 miles or so, but activity in general, especially during the early evenings has been extremely low. Equally the weather has not been at all helpful or encouraging. 70 cms operation has been a dead loss. G2FKZ could not be heard, and G3FZL has been called up. G3GZM has heard GW2ADZ once at 579 which was very good considering the path. Activity during the latter half was seriously curtailed, what with a crystal deciding to refuse to oscillate, and a fringe TVI problem Bill has decided to rebuild the Transmitter. This will probably take a month or so, so do not expect to hear GW2ADZ on the band again until the end of January or the beginning of February.

Another station in the throes of rebuilding is G5GX (Leven, Yorks.). Malcolm agrees with our comments regarding the Zone Plan and says: "Without it the band would be chaotic and we should return to the days when there were nine stations on in Hull, all at once, and they had to take it in turns to work the DX. It is quite easy now, when the DX is there to work!" G5GX is looking for a design for an efficient 2 metre beam with low windage. If anyone has any ideas please

drop him a line. A new station will be operating very shortly in Cottingham, East Yorks. Call sign is not yet issued, but the gear is ready for 430 and 144 mcs. Very few signals have been heard during the month and G5GX says his QRP 3 watts by the fireside does not get out very far!! At some time in the not too distant future G5GX will be moving QTH to Hornsea, East Yorks. (From what your conductor remembers of the Hull district, this may prove a better "firing point" for 2 metre DX. A nice stacked array on the end of the Saltend Jetty might be even better!) It might come as a surprise to G5GX to know that we have actually walked the whole length of that jetty! Hi.

Talking of jetties and such things, we wonder how many times Captain Eddie Clarke G8AO/MM has passed Hull during his innumerable voyages up and down the East Coast? G8AO writes to say that he is changing ships, from the S.S. *Chessington* to the M.V. *Mitcham*, and hopes to be operating again by the time this report appears. The schedule with G4DC continues, but many of the other schedule stations have not been heard for a month or two. G8AO also complains bitterly about the lack of 2 metre activity. When in London recently he listened from 2130 to 2210 and did not hear a single station reply to his CQ's.

The gales recently have rather curtailed operation from the ship, because says Eddie: "Even the best of beams do not like working under water!" (Keep up the good work OM, and don't forget that Ei2W and the boys in Ireland are looking for a QSO with you).

One of the more remote stations in the Eastern half of the country is G3VM (Norwich). The actual QTH is in New Costessey, and owing to the lack of local and semi-local activity G3VM has to rely mostly on 100 mile or so contacts. Although business QRM has prevented much activity over the best part of a year, G3VM has put in quite a number of hours on the band, but has found activity to be extremely low. He has drawn a circle on his map covering 100 miles radius from his QTH and never ceases to wonder at the small amount of activity which takes place with any regularity within that circle. "One often reads of the regular activity which is supposed to take place during T/V hours," says G3VM, "but it *all* misses my receiver between 8 p.m. and 10.30 p.m."

Fred has been operating on the 2 metre band for just 4 years now, and in spite of all the difficulties, poor conditions, low activity, etc., he has been sufficiently interested to make this his main operating band with an occasional excursion to the top band for a little variety. G3VM echos our own feelings when he says, "I feel sure that much remains to be done on

VHF and UHF, and it will be a long time before I can leave the band with the feeling that I have nothing more to learn about it." (No truer statement was ever made. We entirely agree with these comments made by G3VM. We have only touched the fringe in many ways in VHF technique. In spite of the advance in converter design, there is still a lot to be done in this direction alone. The aerial question has in no way been thoroughly explored. New ideas are germinating every few months, and we feel that it would not be over optimistic to forecast that within the next three years the VHF converter and the VHF beam as we know them today, will be hopelessly out of date). Anyway, it is good to know that in spite of the handicaps, G3VM intends to stay put on the band. Settling course a few degrees south of west from Norwich we arrive at Coventry and G5ML, who has not been quite so active of late, due to conditions and low activity. Fred is always "there" however, between 18.00 and 20.00 GMT when activity warrants it. During his visit to the Amateur Exhibition G5ML was pleased to meet again, after many years, that other OT George Jessop G6JP (which reminds us, we have not seen him lately either!). A notable acquisition during the London visit was an AR88LF! A pair of Eimac 4-65a tubes, eagerly awaited for 12 months, have now arrived, and G5ML will shortly be QRO with 150 watts. Since Dec. '51 an 832 with 15 watts input has been used, and Fred hopes for some really good results with the new tubes and his 16 element stack.

A 70 cms PA, consisting of a QQV-06/40 tripler is ready for operation and when the aerial is completed, G5ML hopes to be putting out signals on this band. (Thanks for the report OM, and to scribe Ray Bastin for putting the pen to paper!) From the optimism of G5ML to the dejection of G3HZK (Hayes, Middx.)! John is suffering from converter trouble, and offers a suggestion to those who can hear the DX but cannot work it. "Get a converter like mine" he says, "I never hear any DX on it." (Knowing G3HZK as we do, we happen to know that will tackle this trouble very soon. John's real trouble is finding a suitable design for a fixed roof space array. If anyone has any ideas on the subject please drop him a line, c/o us if you like). G3HZK agrees with us that the space allotted to Zone J in the Zone Plan is insufficient, and suggests that a spread out could take place at the HF end where the activity seems to be least. He hopes to be on phone before Xmas, so by the time these notes appear some of the London area stations at least may know what his voice sounds like. Recent activity has been limited by Exams, but now that these are over, more time will be spent on the band.

Notes from Ireland

Although in the midst of organising various activities, including the big gathering at Athlone on the 24th of January, Ei2W has found time to drop us a line with a few notes. Harry is rebuilding the Aerial and Transmitter, and will be returning to the band about mid-January. Gi3BIL and Gi3QOB are now operating in their correct frequency zone. Ei3S and Ei6A are now definitely on the band, and Ei9C has been working locally. Owing to the difficulty in obtaining spares in Ireland, some stations are finding it difficult to get on the band quickly, but it is expected that at least 20 stations will be operating by the Spring. (Thanks for the note Harry). We also hear from Ei6X (Castleconnell, Co. Limerick) that he is going all out to get on the band. Don't forget to let us know your frequency OM.

In spite of the low general activity, quite a nice bunch of reports again, and as we had to rush this to the printer a little earlier this month we should like to apologise to those late arrivals who may have been left out.

Listener Section

We start with a few comments by J. E. Harman of Eastbourne. Jack is the well known 2nd Op. at G3DIV, and from a purely listener point of view, the 1952 conditions on 2 metres were very much down on the previous two years. The Continental activity was lower, and there were nowhere near the number of openings to the Continent or to anywhere else. He says people in other parts of the country may not agree with this, but that was the position on the South Coast anyway. Jack tunes the band each evening as a matter of course from 7.30 onwards, and thus gets a good idea of conditions from week to week. The only really reliable direction under almost any conditions appears to be towards Cambridge. G3WW, G4MW, and G2XV can always be copied when they are on. At the moment Jack has aerial trouble, and as soon as the weather allows it some ladder climbing will have to be done.

(Thanks for the welcome note Jack, also for scribbling the 'DIV report).

That diehard listener Len Whitmill of Harrow Weald reports some *good* conditions on the 28th November! We so seldom hear such comments that this is quite refreshing! The Cambridge and Northampton stations were very well received on that day. The modified RF27 and pre-amp are still in use, and appear to be working well. The total of different stations heard on 2 metres now stands at 440 in 40 counties. On 70 cms nine stations in five counties have been heard. The 70 cms aerial has been repaired after recent gale damage, and the elements cleaned up. The converter, a 6J6 doubled and trebled into a Lecher Line, and using two matched CV101 crystals,

provides about 75 per cent. of the signal strength of the same station on 2 metres.

During the period between November 7th and December 1st the following stations were heard on 2 metres: G2AHP, BM, DUV, HCG, HDZ, KF, MV, XV, G3BLP, EBW, EEI, ENI, EYV, FAB, FSD, GDR, GHI, GHO, IA1, IIR, MI, SM, G4DC, RO, SA, G5DS, DT, G6BO, LR, NB, NF, WU, G8OU, SK, TB, DV/A, G8AO/MA.

And on 70 cms, G2DD, WJ, G3ECA, FP, GDR, G5CD, DT, RD.

More interesting news from Ray Bastin of Coventry in spite of general pressure of work and the cold weather. As 2nd Op., scribe, and factotum in chief to G5ML, Ray has a busy time of it, but even he has found the roads so bad during November that it was only possible to visit Fred once. Ray has a lot of work to do in the shack (when time and XYL permit !), and in the New Year a start is to be made on a complete portable transmitter/receiver utilising a 522 chassis. The output stage will be two 6J6's in parallel and the receiver will have two 6J6 RF stages, mixer, and CC oscillator with an I.F. of 14-16 Mcs. This job will be used for Field Day work by himself and G5ML during the coming summer. The aerial will be a wide spaced 5 over 5 Yagi.

Local activity in the Coventry area mostly consists of G6YU, who is active every night on 2 metres and 70 cms. Activity is also being maintained by the Leicester stations G3BKQ and G2FNW.

On the 5th of December the 2 metre band was open to London, with G6YP being heard for the first time (working G6YU). No other London signals were heard, nor G3WW, G6NB, G3BLP, or (Ahem) G6UH !!!

Now we had better hurry up and close this epistle for the month. As Xmas comes in the wrong part of the month for us, the printers are disturbed by the prospect of this issue being late coming out. We do hope that listeners will write in with their reports and comments. So once again, a very Happy New Year to all, contributors and readers alike. Good listening, and may there be more to hear in the near future. All reports by the 6th January please, (8th at very latest) direct to your conductor at 176, Station Road, Hayes, Middx.

73 G6UH.

VHF OPERATORS. Avoid QRM and encourage activity by complying with the 2 Metre Zone Plan.

Zone A & B.	144.000 to 144.200 Mcs. All Scotland.
Zone C.	144.200 to 144.400 Mcs England from Lancs and Yorks Northwards.
Zone D.	145.800 to 146.000 Mcs. All Ireland.
Zone E.	144.400 to 144.650 Mcs Cheshire, Derby, Notts, Lincs, Rutland, Leics., Warks., and Staffs.
Zone F.	145.650 to 145.800 Mcs Flint, Denbigh., Shrops., Worcs., Hereford, Monmouth. and Westwards.
Zone G.	144.650 to 144.850 Mcs Northants, Bucks., Herts., Rutland, Hunts., Cambs., Norfolk and Suffolk.
Zone H.	145.250 to 145.500 Mcs Dorset, Wilts., Glos., Oxford, Berks. and Hants.
Zone I.	145.500 to 145.650 Mcs Cornwall, Devon, Somerset.
Zone J.	144.850 to 145.250 Mcs London, Essex, Middx., Surrey, Kent and Sussex.

The majority of VHF operators in the country are operating according to this Plan. In all fairness to these operators, we ask everyone, if at all possible, to operate in the frequency zone applicable to their own area and thus avoid DX QRM.

Putting Us Over. (Contd. from p. 12).

The result of all this, I am sure, would be to at least convince the gathering that we are quite normal folk, who take to our hobby and get a kick out of it as others do with gardening or stamp collecting. Incidentally, the QSL card might quite well be compared with stamps from the collecting aspect.

I am sure such a talk would make the people concerned realise the vast world open to them at the turn of a switch. I think we owe it to ourselves and our hobby to make the facts of it better known. Have no fears that it would be cheapened. It is indeed a fruit, the appreciation of which I am sure the sincerest of us would wish to be shared.

FIRST YEAR LAMENT

*With my ten watts I'm spending lots of time on
eighty metres,
Pitting my puny QRP against the record beaters.
The QRM I get from them, I hardly care to
mention,
And before I get DXCC I'll draw my old age
pension !*

*The HF bands, for distant lands, are better, that
I'd bet on,
But eighty metres is the only band that I can get on.
Ah ! Woe is me, with my QRP and my quarter
wave sky wire,
I'd raise DX in plenty, if I could get it three feet
Higher ! !*

G3HTI.

AMATEUR BANDS COMMENTARY

by

STANLEY HERBERT, G3ATU

This month, a heavy mail shows a considerable divergence of opinion on the subject of conditions. Most of the Twenty Metre gang are considerably "browned-off" with the way the DX has failed to come through. Night-time sessions in particular have been a waste of time, but there *have* been some good openings in the day and early evening periods for those lucky enough to catch them.

Fourteen Metres, still very much a "week-end" band, has had some brilliant moments. On one Sunday in particular, all Continents were coming through at one time or another and there were some strong phone signals from such areas as VP6, VE and VQ2. Things, in fact, are commencing to cook on the band.

Ten Metres on the other hand is sleeping so soundly that not a single snore can be heard. One of these days, a peppering with potent solar particles will bring it out of its hibernation—then, watch out! We'd warn the newcomer that when Ten really opens, an S9 signal will seem weak. It will take S12 or thereabouts to break through the QRM!

Right now, the LF bands are the ones to watch. Forty has been throwing up signals from far-away places even in the early afternoons. Recently, we worked W6DFY at 1500 and YI2AM a few minutes later. At the same time, UG6, U18 and UD6 were pounding in and an OE1 was heard calling FB8ZZ! All reminiscent of Twenty on a good day.

Eighty has been throwing up quantities of "queue-worthy" DX any time after dark and so has Top Band, where OK and OH have been good signals as early as 1700. Later on, things have been even more interesting, as later reports on the band show. So, if Twenty gets you down, don't give up in disgust, QSY to another band and have fun.

And so to business. This time, to give an idea of current activity on that band, we open with

The Fourteen Metre Band

D. L. McLean (Yeovil) agrees that activity is mostly week-end. He picked up CN8, FA, FF8AR, 8CN, 8GP, OD5, PY, SVØWP, TA3AA, VE1CR, 3AIU, 3KF, VP6SD, YI2AM (09.45) and YV5AB.

FF8AR and 8GP are both at Goa, French Sudan, which says D.L.Mc., appears in some Country lists as a separate one with the prefix "FD8."

Actually, the town is Gao, but French Sudan is merely a small part of the vast territory comprising French West Africa. It is no more a separate country than, say French Guinea or Dahomey, all three of which use the FF8 prefix.

K. J. Gurney (Aylesbury) is now the proud possessor of an Eddystone 358x—a big improvement on his original 1-V-1. The new Super, with a cathode-follower Preamplifier, pulled in Phone from AP2L, OD5AB, VE3KF, VP6SD, VS7WA, VK2LJ, YI2AM and ZE2JV.

J. Whittington (Worthing) heard SVØWP and, on CW, W2WZ and some CN8's. All in all, he doesn't think much of recent conditions!

N. C. Smith (Petts Wood) found the band interesting, with CW from AP2K (1,200), LU2DAW, OQ5, PY, TI2TG (1,610), UA, UN1AF, VE2 and 3, VK2 (1,100), VK3, VK4HR (09.00), all W Districts but 7, ZL4BO, 4GA, 4JP, all around 1030, ZS2 and 6 and VQ2DT. Phone produced some interesting DX in VS1AY (1035), HZ1MY, SVØWP, TA, VE3AIU (1700), VS6WA, ZC4RX, 3V8AP and ZE2JV.

For the band, Norman uses a folded dipole running N & S, with a single wire reflector spaced 3 ft. 6 inches on the West side. This beam gets VK and The East quite well, but it does a much better job on the W's. Which reminds us of a fixed three-element we once had, directed on Hawaii. It was a terrific success—as far as South Africa was concerned—but it never did raise KH6!

B. J. C. Brown (Derby) found three new ones in CN8MM, VE3KF and VP6SD, the latter being particularly strong.

R. Balister (Croxley Green) wound a coil for his O-V-1 and was rewarded with VP6SD, VS7WA, VE3KF and YV5AB and, on CW, W1 and 4, VE1 and KP4KD.

Other countries known to be active are I1BLF/Trieste and IS1, while SV5UN promises to be on the band in due course.

As is now common knowledge, U.K. Amateurs are now allowed to use Phone. The whole band -21000 to 21450 is open to us and activity should increase considerably as a result. We hope, too, that U.K. Phone stations will set an example to certain other countries by conforming to the Band Plan

and keeping within the frequencies 21150-21450. Three hundred beautiful kilocycles seems fair enough at that.

Twenty Metres

C. J. Goddard (Warwick) comes forward with CW including a nifty LB6XD (Jan Mayen Is.), ZS6ZU/P (Marion Is.), MP4BBB (Bahrein), CR7RF, HC1FG, 2OT, JY1AJ, SU1JQ, Y13EOR (a new one ?), ZD2DCP and ZE3JP. On Phone, he was interested to hear CO6LG, 8GM, HZ1MY, TI2RCA, VQ5AU, VS7DR, 9AW and ZD4AE.

H. Lee (Oslo) found conditions best between 1500-1900, when his PCR-1 and vertical picked up Phone stations KP4AC, MP4KAC, OD5AJ, OQ5BC, VE8PE, VK2ANH, VS9AW, W4NXJ/VO2 and ZD1SW.

V. Doidge (Callington), with his two-valve battery job, pulled in CN8GV/AM, CR6AG, CS3AC, CX2CO, HC1AB, VK2ID, VP9AK, VS1EG, ZE3JN and ZA1AA. (We worked the latter recently on Phone, but only a QSL—which we don't expect to get—will convince us about this chap).

R. W. Cresswell (Basingstoke) uses a "Basic Superhet" on which he has heard lots of Phone DX, the pick of which is provided by EA6AT, VS9AW, ZS2BJ, EA8BE, YI2AM, HP1CC, ZS3N, VP7NB and SV5UN (Rhodes). He asks for the whereabouts of KT1 (Tangier), 5A3 (Libya) and AG2 (Trieste).

P. M. White (Williton) wasn't exactly tickled with things on Twenty. In fact, he even started listening on the SW Broadcast Bands (poor show!). However, HC1FG, HP1MD, LU6AJ, 2FN, ZS6BW and OX3MW did something to prevent a permanent departure thereto!

D. E. Lord (R.A.F. "MEAF, 10") is now using a battery O-V-1 with a 33 ft. vertical aerial. This combination pulled in Phone from AP4U, CE3AB, CR4AC, FF8AP, HC1DR, KL7ZG, KB6AO, ST2GL, VK7KB, VS2BS, VU2MA, ZD7A, XD9AA and several ZL's. Things seem quite lively in the land of fies and camels.

J. M. Gibson (Darlington) is a young listener who promises a report next month. In the meantime, he has a QSL from "Red" Fenton of ZD9AA. It came direct and took only four months.

P. M. Crawford (Darlington) is another one to have a thin time of it recently, he complains. "Good Old Twenty has been out," says he and then talks of phone from VU2MA, CR4AI, XE1HE, KA2AM, OX3BI, and numbers of ZL and VK. If it gets no worse than that, Martin, it won't be too bad!

D. Wilson (West Hartlepool) is a keen Phone listener; using a R1155A and a 33 ft. Windom, his score since November is 60C, the best being AP2K, EA8BC, HZ1TA, KV4BB,

MI3LM, MP4KAB, VK6MF, VP9AV YI2AM, ZC4RX, ZS2, 5, 6 and ZL2BE.

H. D. Woodward (Manchester) is another new reporter to these pages. He offers HP1MD, KP1MD, KP4JD, VK6DX, W5OCH, ZD4AX, 4BL and ZL2BE as his best on Phone, with a nice one—FM7WD—on the key.

Bill Hardie (Hawick) settled for DL4OH/AM, HZ1AB, 1TA, SU5EB, MP4KAC(0715), ZD2RRW, ZL2BE, W4NXJ/VO2, W2OJ/VO and DJ1HM. The latter, giving his QTH as Hamburg, puzzles Bill. However, DJ stations are newly licenced Germans. Instead of starting the series—DL1AAA, etc., the Authorities used "DJ" and kept things tidy.

R. Goodman (Edgware), who recently put up a dipole running N & S, finds his results much improved, not only on Twenty, but also on Eighty. He now gets good signals from ZL, KG6, etc., but is puzzled by the way he can pull in Africans off the end of the aerial. See previous remarks about directivity!

He would like to see a contest put on solely for O-V-O's, so that he can see how his own little receiver compares, but we would say he is being rather modest. His results compare very well with many of the superhet gang's as it is.

The recent Phone results show CR6AJ(1800), HC1FG, HK4HV, KA7SL, KG6AAS, 6ACS, M1MO (still at it!), OQ5AU, VE6PP, VQ4, VP2AJ (who uses 9 watts only), YV5, ZD4AX, ZS6ZU/P, four ZL'S and VR4E, S7 to S3. The operator had an American accent, and it looks as if the VR4 is quite genuine.

R. Balister found the band pretty hopeless and has almost deserted it for the lower frequencies. He managed W2OJ/VO2, W7LVI and, on CW, ZS1H, FF8AR and ZL2GL.

P. D. Lucas (Redhill) listens mainly from 1930-2030 and has had little luck, Phone from VU2CK, HC1FG, PJ2CB, VP6AL and CW from ZS1NO and VP9AU were snagged.

He is thinking of changing his 14 Mc dipole for an Eighty Metre half-wave long wire; lucky fellow to have the space—a wire like that should bring in the DX on all bands.

P. D. L. is taking a Morse test soon and has applied to take his RAE next year. Good luck; we hope a new "G3 plus Three" call will result.

G2UK (Oulton Broad) whose call-sign should not be unfamiliar to readers of this journal(!), had great fun one recent lunch-time. He raised VK3RW (Melbourne), who gave him S9. A solid twenty minute QSO resulted, followed by one with VK5AJ. VK6MK called in next, then, as usually happens on these occasions, '2UK was called away to work. The rig is 150 watts input, used with a tuned feeder half-wave dipole, which must be doing its stuff very efficiently, as the QSO's were made through the usual babel caused by

Southern Europeans shouting "CQ DX" around the frequency! Some of these chaps will never learn.

N. C. Smith hasn't wasted a lot of time on Twenty recently, having been using his talents to better advantage elsewhere, as will be evident later. However, the following CW shows that the band did have its moments. CE3AG(1155), KH6AJH, 6IK, 6ES (all 1815), KL7TI, VE7HP, ST2GL, ZS2MI and VK1PN (1655 and 1800). This chap is on Heard Is. and has a chirpy note. Phone DX was VS9AW(1610), ZS6ZU/P(1900) and ZS4F. PX1YR was active also. Norman is glad that the fitting of suppressors to cars and various electrical equipment is to become law and adds that all that now remains is for someone to do something about the odd bods who can apparently push their power up to a kilowatt as required!

J. Whittington says nothing much has happened to him this month. He settled for Phones CR6AM(1900), CR6AT, VK6DX (1400), ZD4BL(1715), ZS3N and ZS3S(2100), with YV5BQ at 1215.

G2HMI (Sunderland) who puts a good signal into S. Africa and skeds ZS6TE and 6AFF, recently worked ZS6ZU/P, getting a very poor report. This shows how difficult it is to penetrate the extremely heavy absorption which exists both in the Antarctic and Arctic regions.

D. L. McLean pressed on with Phone from CR6AT, CR4AD, FF8, HP1MD(1415-1910), KA3IM, MP4KAC, SV5UN(1430-1750), VE8OP(1840-Baffin Is.), VE8SF (Nottingham Is.), VP7NB(1845), several ZL'S, ZS6ZU/P, ZS's, ZS3O, ZP5 and ZS9G.

B. J. C. Brown (Derby) agrees about conditions both on Twenty and in his shack, where blankets and hot-water bottles were necessary at times. Despite numbed fingers and frozen ears, he knocked off ZS9G (a new one) and MI3LK, SU5EB, VE8PE, ZD4AX, ZL2BE (very consistent) and W6DI.ZB1RM and a 5A2 were on CW.

R. Winter (Melton Mowbray) reports for the first time. In an interesting letter, he tells us he started listening in 1946, when he became ISWL Rep. for Leicestershire. Army service intervened and he became second operator at DL2LC (Belsen). Richard is now settled again in civilian life and is taking a refresher course for the RAE.

In the meantime, he is listening keenly and threatens our regular chasers with some real competition. Good show—a little friendly rivalry makes all the difference. The main receiver at present is a 1224A Super, but an S640 is expected shortly.

Preliminary results on Phone show AG2AF (Trieste), CN8's, KV8BF(?), M13MK, OX3BD,

TF, W7LVI, W2OJ/VO2, ZCIAH (sounds interesting) and lots of short skip.

G3ATU (Roker) has nothing wildly exciting to report. He hears FM7WF on Phone from time to time (1422-1730), also M1B on Phone in the depths of the CW band. Whether it was the genuine M1B is anyone's guess. On CW, up came SP1V with a nice T9X note, calling "CQ Fb DX" and getting lots of attention too! Well, well.

And that is all we have to say about Twenty. Pretty average grim for the time being, but rather a different state of affairs has prevailed on the LF bands, which we deal with now, starting with

Eighty Metres

R. Goodman with his O-V-1 and new aerial pulled in CN8GP, KP4CP(0100-S9), KTIAK, VE1QW, W1, 2, 8UKS and K4FGC, all on Phone, bringing his Eighty Metre score to 12Z-35C.

N. C. Smith stuck to CW, unearthing CN8AF, FKS8BC, KP4AN, 4DJ, VE1FR, 1ZZ, 2UL, UA1 to 4, UB5, 9S4BB, WN1, 2 and 4, W9NJB, 9OLU, ZL3PJ and 4IE (0800), and two beauts—VP8AP (0410) and ZS6ZU/P (3524-1900). He heard a weird BC station on 3840-0330, with Eastern chants and a Russian (?) on 3892 giving what sounded like fat-stock prices! Norman tells us that G. Allen picked up UA9WC at 0400 on the CW end of the band.

J. Whittington cocked an ear on the Phone band and emerged with KP4CP, 4MX, VE1AA, 1QW, VP7NB (0200), W1, 2, 8UKS and 9OLU/4.

K. J. Gurney hears W and VE most evenings from 2230, a big improvement on last year. Good DX for him was EA9AR, 9BA, 9BC, VP7NB, VP9DH, OX3WX, OY3PF, HR1BG, WØDCP and a KP4. Yes, sir.

For two years K.J.G. has tried in vain to hear W6, 7 on the band. Now that he has his new receiver, it should be only a question of time.

B. J. C. Brown weighs in with VE1QW and W1ONG.

One-Sixty Metres

From the way things are shaping on the Top Band, even at this early stage in the proceedings, it looks as though we might expect some really hot DX openings before the Winter is out.

Skip has been getting long just after dusk and we have heard OK's quite strongly as early as 1700 and OH an hour or so later.

G2FXA (Stockton) tells us of working G8KP one night, around 2300. In the course of the QSO, 'FXA heard a station calling "CQ DX." It turned out to be MF2AG and '2FXA, whose Top Band aerial is not too good for long range stuff, sportingly let '8KP have

the first crack, which resulted in a QSO. MF2AG then stood by for the Stockton station, but was unable to hear him, which seems exceedingly hard luck.

J. Whittington has heard lots of DX BC stations between 980 and 1500 kcs—always a good sign of favourable conditions for Top Band DX—but he was unlucky in missing OH7OH.

N. C. Smith copied the OH at 0420! He passes along the news that John Hall heard WILYV recently at 0515, which is really something and adds that the two of them have hopes of hearing W6AM a little later in the season.

R. Balister heard his first DX on the band by picking up OK1HI, while B. J. C. Brown, although missing out on DX (a state of affairs which we feel is purely temporary), managed lots of UK, both CW and Phone, the best being GM3HXT (Moray) at 330 miles. **Forty Metres**

"Old Messy," we are glad to see, has had lots of attention this month and a glance through the calls heard should convince doubters that real DX is very much there in spite of everything.

N. C. Smith, for instance, pulled in the CW of AP2K (1800-1900), CT2AE, CE2GB, CO6PP, FF8AG (2140), FM7WD (0400), HRIAT (0430), KV4, LU, MP4BAU (2130-Quatar, which now counts as a country), TI2MAR (0345), OA4ED, UD6, UG6, UH8, UJ8, UI8, UO5, VK3ANJ (1830), 3KR (0730), 6WT (2150), VP8AP (0300), VP9BF, W5LP, ZS6OW (0330), six ZL's and lots of the commoner DX. He has also heard Russians on Phone at 0345, working HA's and laughing!

C. J. Goddard heard Phone from UA2KAW, 3KQB and 6KSA (he doesn't tell us whether they were laughing!) EA8BD, FA8IH, 9RZ, ZC4RX, 4X4 and 5A2.

D. L. McLean, who is very close to a BBC station, still managed EA9AW, 9BC and YI2AM.

H. Lee turned up Phone from HH1E, OD5AB, VQ3DN, VQ4BC, VQ5DQ and ZS9I.

H. D. Woodward got YU, ZB1, VE2IF, CN8CY and EK1HH—all new ones for him.

P. M. White's new ones were GI, GD and a VS7.

R. Balister logged 4X4BL, OD5AB, TA3MP, YI2AM and HB9PS/MM (somewhere at sea). This lot were on CW.

G3ATU, whose log is looking rather anaemic these days, did manage to hear 4UAG (Karachi-1930), LB2WD (who may or may not be in Norway), sundry LU and PY and CT3AA. SV5UN is active, too—CW.

Just count the DX countries in that little lot, then check the number that very rarely turn up on Twenty. It really is quite surprising.

Sundry Pieces

Dick Mc Kercher, of HZ1MY, is off on his travels again in the near future. He is going to Portuguese India (CR8), and we hope to hear him signing CR8MY some time in February.

SV5UN has two operators—a W3, who does the keybashing—and W2PED (Paul), who collects the sore throats. Current activity is Forty CW and Twenty Phone, with plans for Ten and Fourteen well advanced. The station is liable to be active for a considerable period, so that nobody need panic.

As we mentioned earlier, The Sheikdom of Qatar is now officially recognised as a separate country for DX purposes. If anyone heard or worked MP4BAM some months ago, they can chalk up Qatar. 'BAM operated from there, although his postal address was Bahrein.

Don't forget to keep watch for CE0AA (Easter Is), who may be hitting the Ether about now. He won't be there for long, so an almighty battle is assured.

QSL's Received

D. L. McLean has collected from CT3AN, EA0AD, OQ5CA (21 Mcs), PY2BKH (7 Mcs—first report received from outside Brazil), VP5BF (Caiicos Is.), W4JZQ (3.9 Mcs), ZC6AG, ZD9AA, ZS6JF (26 months) and 4W1MY (by return).

J. Whittington has cards from PJ2AA and VS1DS—Twenty Phone.

B. J. C. Brown—PY2AUC (28 Mcs—air mail).

Just as we were closing for press, in came a letter from G. B. Moser, G3HMR (Windermere, Westmorland), which will be of particular interest to Top Band county chasers. '3HMR expects to be active on that band by the end of December and should be assured of large numbers of QSO's. He will QSL 100 per cent. upon receipt of the other fellow's card.

During the past month, Guy has heard OK1AEH, OH3QR, OH3QR and such semi-DX as GM2CAS (Aberdeen), G2FP (Exeter), G4VZ (Dorchester), G2FIX (Salisbury), G3HFQ (Weymouth) and G3GGN (Worthing).

Thank you to all the kind souls who have sent us their Xmas Greetings and apologies for our forgetting to do so in the last issue. Please take them as read and accept our wishes for a 1953 crammed with rare DX, exotic QSL cards and everything you could wish yourselves.

Please send your first reports of The New Year to reach Roker House, South Cliff, Roker, Sunderland, by first post January 7th at the latest.

Good hunting in '53, 73.

CLUB NEWS

Club Secretaries are invited to submit notes for this feature by 12th January, for inclusion in next month's issue.

West Lancs Radio Society. Hon. Sec.: B. J. Whitty, G3HWX, 46, Argo Road, Waterloo, Liverpool, 22.

A very interesting lecture on the production of wire, was given by Mr. Arthur Looney, of the Liverpool Short Wave Club, recently which was well attended. The following week a trip was organised to the automatic telephone exchange at Lancaster House. This was followed by a visit to Seaforth Radio Coast Station. Both trips created much interest.

Due to the amount of outside attractions, Morse practice has been temporarily squeezed out, but will be resumed later in December. Another keen YL has joined the happy throng, bringing the grand total to four.

Refreshments at the Club are in the hands of Stella Maguire who has handled that side of the business most capably since the Club started.

On the 9th December, a lecture was given by G3CSG on Japanese Morse. Early in January, the local interference officers are coming along to give a talk on BCI and TVI.

Meetings are held on Tuesdays, 8 p.m. in the room over Gordon's Sweet Shop, St. John's Road, Waterloo. New members—including YL's—always welcome.

The Television Society

The Annual Exhibition of the Television Society will be held on January 23rd and 24th, 1953, at 155, Charing Cross Road, W.C.2 by the kind invitation of The Edison Swan Electric Company Limited. The Exhibition will be open as follows:—

January 23rd, 6 to 9.30 p.m. Members and friends.
January 24th, 10.30 a.m. to 6.0 p.m. Members.

Public admission by invitation card.

All exhibits are closely related to Television Engineering or Production or to the Production of Television Programmes. Tickets of admission may be had from Society members and Patron Members or from G. T. Clark, Lecture Secretary, 43, Mandeville House, Worsopp Drive, London, S.W.4.

Hastings and District Amateur Radio Club. Hon. Sec.: W. E. Thompson, 8, Coventry Road, St. Leonards-on-Sea.

At the meeting held on November 18th two lectures were given, one on the principles and circuitry of radar by J. D. Heys (G3BDQ), and the other on mechanical and electrical design features of 3,000-types relays by W. E. Thompson. Both were received with interest and both speakers have additional material to present at future meetings to complete their lectures.

The Committee has drawn up a tentative programme for the early 1953 meetings so for the next three months at least members can look forward to several interesting sessions. Meetings will be held on January 13th and 27th at the Saxon Cafe; VHF Aerials is the subject for the first meeting, and Tape Recorders for the second.

Coventry Amateur Radio Society. Hon. Sec.: K. Lines, G3FOH, 142, Shorncliffe Road, Coventry.

With a varied programme during November, including a Sausage and Mash Supper, Junk Sale, M.C.C. Contest, lecture on "Workshop Practice," by "Monty" and the regular monthly Night-on-the-Air, the Society has had a successful month. New members are needed, and will be welcomed at any of the regular fortnightly meetings held at the Y.W.C.A., Queen's Road, at 7.30 p.m.

Visitors will also be welcome at the Lectures, details of which are given in the forthcoming programme below:—
January 5th: "DX on a Landline," by Les Gardiner, G5GR.

February 27th: 21st Anniversary Dinner—application for tickets to Hon. Sec.

Manchester and District Radio Society. Hon. Sec.: K. Brockbank, 17, Burleigh Road, Stretford, Lancs.

Meetings are held on the first Monday of each month at the Brunswick Hotel, Piccadilly, Manchester at 7.30 p.m. New members are very welcome and should communicate with the Hon. Secretary.

Yeovil Amateur Radio Club (G3CMM). Hon. Sec.: D. L. McLean, 9, Cedar Grove, Yeovil, Somerset.

Meetings are held every Wednesday at 7.30 p.m. in the club room at the British Legion, Preston Road, Yeovil. The club station is at present "off the air."

The 75 watts transmitter for the 3.5-21 Mcs bands is under modification for the addition of 28 Mcs operation. A 813 PA will also be added, running 150 watts input, and screen modulation for phone operation. A six foot metal rack, with each section totally shielded from each other has been constructed. Also under construction is a wooden console for the operating table. This will house VFO - receiver - oscilloscope - frequency meter phone/CW monitor. G3BEC—a member of the Tops CW Club—operated his QRP rig on behalf of the club, during M.C.C. Recent visitors have been the Mayor of Yeovil and the local Member of Parliament. Both were very interested especially in the QSL's.

Purley and District Radio Club. Hon. Sec.: A. Frost, G3FTQ, 18 Beechwood Avenue, Thornton Heath, Surrey.

The next meeting will be held on Thursday, January 22nd, 1953, at 7.30 p.m. at the Railway Hotel, Purley. Arrangements are in hand for our Annual Dinner and Xmas Party which will take place on February 28th, 1953, and which we hope will be even more successful than last year.

Meetings continue to be well attended and membership is increasing steadily. New and prospective members are cordially invited to attend any meetings or functions or contact the Secretary for further details.

Southend and District Radio Society. Hon. Sec.: G. Chapman, B.E.M., Bell Hotel, 20 Leigh Hill, Leigh-on-Sea.

A talk by Mr. R. K. Seabrook on "The Construction of a D/F Receiver," was given on 12th December.

Mr. Seabrook took second place in the R.S.G.B. National Final Direction Finding Contest held in September in the neighbourhood of Hitchin, so he knows his subject.

The previous year, second place was taken by Mr. G. T. Peck, who is an honorary member of our Society. It is very gratifying that we have done so well for two years running. If members follow Mr. Seabrook's instructions we may do even better next year.

Members who attended our last meeting in our new quarters were delighted with the accommodation which has been provided for us in Room "L" by the Municipal College authorities. Our thanks are due to Messrs. Asquith, Marshall and Varcoe masters at the College—who turned up to welcome us.

There will be no further meetings this session, but we shall reassemble on Friday, 9th January, 1953.

Tops CW Club. Hon. Sec.: J. Philip Evans, GW8WJ, 2 Forddy Newydd, Meliden, Prestatyn, Flint.

The membership of the club is now over 200 in at least twelve countries. YU1AD, SM7BO and EI9Y are recent recruits.

The following Tops Members are congratulated upon their success in various events:—

G3AGQ 1st; GC2CNC 2nd; in the Kaleveld Trophy. G3CED 3rd.

G3EBH won the 1952 FOC Marathon. G2AOL won the 1952 RSGB LP Contest.

A Midlands Topfest will be held at Wolverhampton on Saturday, April 11th, 1953. Non-members will be welcome. Send SAE to GW8WJ for details. Tickets for Tea and Meeting at 6/- each. For Meeting only at 2/- each.

The Hester Trophy Contest will take place in January or February, 1953.

Readers interested in joining Tops are invited to write to 8WJ.

Slade Radio Society. Hon. Sec.: Mr. C. N. Smart, 110 Woolmore Road, Birmingham 23.

At the recent A.G.M. a new President, Mr. W. E. Chilvers was elected, together with other officers of the Society. In future a period of threequarters of an hour before each meeting will be given over to a Morse tuition class, for members intending to take the P.O. examination.

On January 9th there will be a lecture on radio frequency heating.

Meetings are held on alternate Fridays at 7.45 p.m., at the Society's headquarters, Church House, High St., Erdington. Visitors are always welcome.

1952 RSGB EXHIBITION

BOOK REVIEW

Your contributor attended this well-known yearly event at the Royal Hotel, W.C.1, on the evening of Thursday, November 27th. The exhibition was, as usual, well attended by amateurs, SWL's their junior "ops," YL's and XYL's, plus a few "fellow travellers" in the radio art. I observed the presence of many well-known amateurs both of London and the provinces, and should imagine, by the vast number of small discussion groups which soon formed, that many QSO's were being cemented by personal contact.

My first call was at the amateur television stand, and I was delighted to find that the gear in use here had acquired a more professional atmosphere than of recent years. Some very comprehensive equipment, mounted in a rack, BBC style, was being used to supply and control the picture camera and included picture and waveform monitor scopes. The T/V demonstration was given that final touch of perfection by the use of a 70 cm. radio link to the other side of the hall, where a "Magna View" T/V Rx. was in use with an amateur constructed converter. Whilst I was watching, test cards were being sent with very high fidelity, and later, when passing the receiver, I saw the face of G3CVO, a very prominent enthusiast, beaming at me!

Another display which told of a "hobby within a hobby" was that of the SSBSC stand. A comprehensive display of amateur gear caught the eye, together with large and very neat graphs and curves depicting filter response and sideband coverages.

I next called at the "five" station stand, and found station GB3RS on 80, in QSO with a Sheffield station. The noise level from electrical gear both in the exhibition and from neon signs, etc., in the surrounding district wrought havoc at first, but diligent handling of the AR.88 soon brought signals up to S.8, and the large crowd of amateurs were able to follow both sides of the contact with comparative ease. The Tx. in use escapes the writer at the moment, but it is believed that it was either built to a G5RV design or was an actual prototype by that pioneer of TVI suppression.

Several stands and parts thereof were devoted to displays of home-built gear of all sorts and sizes, from field-day Tx's to QRO assemblies, from complex frequency measuring equipment to absorption wavemeters. A very comprehensive valve tester was seen and admired. A few examples of 70 cm gear originating from the Ilford (E. London) area, had recently done yeoman service in the exploitation of that V.H.F. band. Two neat transceivers were used, one at a fixed station and one installed, antenna and all, in a car. Photographs displayed showed the antenna system, also exhibited in the flesh (or should it be the metal?) mounted on the vehicle used. The gear was of the most simple self-excited type and gave excellent results. The experimenters concerned were G8TL/P and G3ECA, whose works are hereby commended and acknowledged.

Both the Army and Royal Air Force contributed interesting stands, but the Army must take the biscuit for interest, and the writer spent quite a long time at this stand conversing with those in charge. A Wearite tape deck and amplifier was demonstrated which the writer duly performed on. A microwave link across the hall was also in operation, allowing duplex contacts to be made with the remote operator. Antenna patterns were displayed on a long persistence CRT, various stacked and parasitic arrays and the latest development, the helix, were seen from their R.F. point of view. Antennas plugged into the top of the unit rotated slowly with reference to a source of VHF signal and the polar pattern was read off the scope. Also demonstrated was a practical illustration of Fourier's Analysis. A frequency generator fed a standard CRT with selected sine waves, and one could, by appropriate switching, generate wave forms containing components up to the fourth harmonic.

Messrs. E. M. J. displayed their tape recorder and part of their range of equipment for amateur use, including absorption wavemeters and microphones. On the A.V.O. stand I was pleased to see for the first time an AVO meter with Braille calibrations. A goodly selection from this company's range of products was also on show.

DATA AND CIRCUITS OF MODERN RECEIVING AND AMPLIFYING VALVES. (Philips Technical Library, Book 111a). Compiled and edited by N. S. Markus and J. Otte. 480 pages, 505 illustrations. Price 40s. Distributed in England by Cleaver-Hume Press Ltd., 42a South Audley Street, London, W.1.

This is the latest addition to the series of books in the Philips Technical Library, compiled by members of the staff in the laboratories of N. V. Philips' Gloeilampfabriek at Eindhoven. Two other works from this source were reviewed in the May 1952 issue of this journal. This present volume is fully in keeping with the high standard one has come to expect from this team of experts.

In a sense, it could be called a catalogue of several valve types, but in all fairness to the authors and publishers the term should be qualified by emphasizing that this is no ordinary catalogue. Indeed, it would be difficult to imagine how else, or where, one could obtain such extensive information as is given for each valve described.

Although there seems to be stress on the fact that the valves are produced in the Netherlands, it is as well perhaps to point out that valves with similar titles are available from British manufacturers, and the characteristics are, of course, alike. Thus, the Rimlock type to which a large part of the book is devoted is the same as the British B8A, that is, an eight-pin glass base with a locating projection on the metal shield. The Noval-based valves also have British counterparts in the B9A series.

The method of dealing with each type of valve is to show a photograph, about actual size (in many cases there is also an accompanying X-ray photograph showing internal construction), give a detailed description of the uses and application in circuits, follow this with extensive data covering typical characteristics, operating characteristics, and limiting values, and conclude with a series of graphs showing characteristic curves for different operating conditions. In many cases the tables of characteristics occupy several pages, and the amount of information they contain is extremely useful. The graphs are particularly clear and informative. It was noticed that in the case of the ECH42 frequency-changer, no less than fourteen sets of curves are displayed, covering every application to which the valve can be put.

Each series of valves is dealt with in separate sections of the book, and a series of receiver circuits designed around the valves in the section concerned is given. These range from a simple four-valve battery receiver to a fifteen-valve quality receiver for A.C. mains. Amplifiers and F.M. receivers are also included. Each of these designs is given much technical description, and useful tables of measured values. In some cases, the design and construction of I.F. transformers applicable to particular circuits is described.

A valve of unusual interest is the type EQ80, a new type described as an Enneode. It has seven grids, some of which are internally connected, and the electrode assembly is thereby accommodated on a Noval (B9A) base. This valve, for which there does not yet appear to be a British equivalent, has been specially developed for use as detector and amplitude limiter in F.M. receiver circuits, and some simplification of circuitry is achieved by its use.

There appears to be an error in the numbering of the curves for the EZ41 rectifier, page 120. Curves 1 and 3 seem to be reversed, for one would expect a higher output voltage when using a higher value of reservoir capacitance, even though the anode series resistor needs to be higher for a larger capacitor.

It is confidently stated that having regard for the wealth of information it contains, this book is offered at a reasonable price. No less pleasing is the binding of blue linen and gold lettering to match other volumes in the series, and the clear type-face employed.

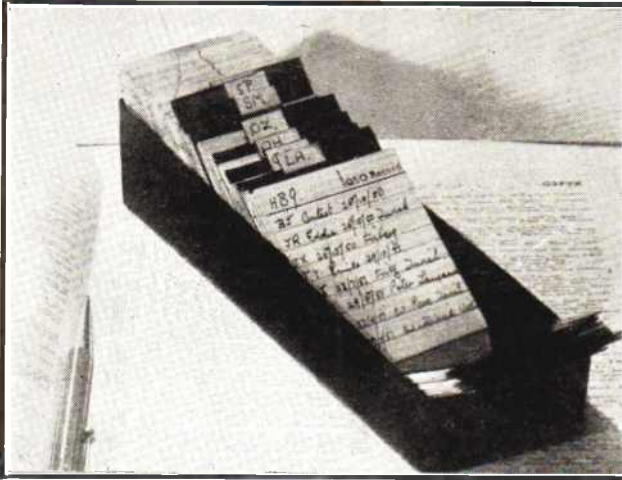

**USEFUL
ACCESSORIES**

**'MINICARD'
RECORD
CARDS**

from

A.S.W.P.

57 Maida Vale,
Paddington,
London, W.9

QSO Record cards 2½ ins. × 2½ ins. printed both sides, available for amateur station records, at 3/3 per 100 post paid. Metal filing trays as shown, heavy gauge steel, green enamel to hold 500 cards, 3/3 post paid.

RADIO BOOKS

VALVE TECHNIQUE (RSGB) - 3/9	WORLD RADIO VALVE HAND-BOOK (O. Johansen) - - 11/9
RECEIVERS (RSGB) - - - 3/9	WORLD RADIO HANDBOOK (O. Johansen) - - - 8/9
TELEVISION INTERFERENCE (RSGB) - - - - 2/3	HOW TO LISTEN TO THE WORLD (O. Johansen) - - - - 1/11
SIMPLE TRANSMITTING EQUIPMENT (RSGB) - - - 2/3	INEXPENSIVE TELEVISION (ASWP Ltd.) - - - 2/8
RSGB CALL BOOK - - - 3/9	TV FAULT FINDING (ASWP Ltd.) 5/3

Above prices inclusive of postage, etc.

DATA PUBLICATIONS

Lyon Court, 57 Maida Vale, London, W.9, Tel. CUN 6579

Published by Data Publications (Amalgamated Short Wave Press Ltd.), 57 Maida Vale, Paddington, W.9 and Printed by Hanbury, Tomsett & Co., Ltd., Kensal Rise, N.W.10

SMALL ADVERTISEMENTS

Readers' small advertisements will be accepted at 2d. per word, minimum charge 2s. Trade advertisements will be accepted at 6d. per word, minimum charge 6s. If a Box number is required, an additional charge of 1/- will be made. Terms: Cash with order. All copy must be in hand by the 12th of the month for insertion in the following month's issue.

PRIVATE

WANTED URGENTLY. Why not turn some of that unused surplus gear back into cash? Good prices paid for BC221's; BC312's, with or without dynamos; BC348's. 813's; 726A's; 4E27's; 250TL's; 450TL's. Box No. B175.

FOR SALE. Astronomical telescope, 3½ in. objective, full range of accessories, six eyepieces, prism and sun viewing eyepiece, table and garden stand, etc. An excellent instrument for anyone interested in viewing sunspots or for general amateur astronomical work. Complete in fitted mahogany case, £30. Jack Cowles, Post Office Farm, Stutton, Ipswich, Suffolk.

FOR SALE. Rotary converter, 12v. 10A in; 450v, 50Ma; 250v. 150Ma out £1. Qualtape Magnetic Recorder Desk, fitted in case, with Tamsa high impedance record/playback head and reel tape. Bargain at £10. Vidor Personal portable £10. "East Keal", Romany Road, Outon Broad, Suffolk.

LS.50. G3HSL, 56 Stockton Road, West Hartlepool, Durham; would be very pleased to hear from anyone who could give him the gen on this German tube.

FOR SALE. CR100 Receiver. All Amateur Bands. Call, listen £25. Mr. Young, "Eastview", St. John's Avenue, Harlow, Essex.

FOR SALE. Qualtape Desk, head changed to a Tamsa high impedance half track type, £6 10s. National 1-10 with valves and 2-3 meter coils, £3. BC453, the Q5'er, with circuit, £3 10s. Westinghouse rectifiers doublers from 350-0-350 to 3kV with circuit, £1. "Wireless Worlds" 1950 and 1951, 6s. per volume. All carriage extra. Wanted—UM2. Box No.: C100.

FOR SALE. "P.C.R." Communications Receiver, new condition, complete with AC power pack, also new 12-volt vibrator power unit, £17 10s. complete, or offers. Wanted—Wavemeter Type W1191A. Box No.: C101.

FOR SALE. "Practical Television" 9 inch TV in Console Cabinet. Complete working order, £35. Frankland, 80 Foster Road, Kempston, Bedford.

FOR SALE. AVO 7 Testmeter, perfect, £12 10s. Viewmaster complete 9in. tube, good picture, £22 10s. Oscilloscope by Industrial Electronics, £18 10s., cost £35. D. Nobes, 445 Streatham High Road, S.W.16.

WANTED. "Radio Constructor," Vol. 2, Nos. 1, 2, 3 and 8. Box No.: C102.

WANTED URGENTLY. R107, 1155 or BC348, must be in good working order. P. Batten, 25 Richmond Terrace, Clifton, Bristol 8.

EXCHANGE. 9 Volumes "Second Great War," cost £13, as new—for Communication Receiver. Box. No.: C103.

TRADE

SPECIAL OFFER. 6s. Kit of parts for constructor's crystal set; ideal beginner's; full instructions. Other items: Crystal diodes 3s. (wire ends.) Silicon type with brackets 4s. Book on crystal sets 1s. 1 x ¼. Mail order only from Technical Enterprises, 3 Tennyson Road, London, S.W.19.

COMPONENTS. Our 1953 Catalogue is now available giving full details of our comprehensive range of components. Watts Radio, 8 Baker Street, Weybridge, Surrey.

METALWORK. All types cabinets, chassis, racks, etc., to your own specifications. Philpott's Metalworks, Ltd. (Dept. R.A.), Chapman Street, Loughborough.

"GLOBE-KING" (Regd.) Miniature Single Valve Receiver gets real DX—Amateur Radio enthusiasts should send for free copy of interesting literature and catalogue (enclose stamp for postage). Write to makers: Johnson (Radio), 46 Friar Street, Worcester.

BOOKBINDING. Volumes of Radio Constructor and Radio Amateur fully bound, imitation leather, gold lettering. 7s. 6d. post free. Prices for other publications on application. Jerome Alcock, CHEADLE, Stoke-on-Trent.

"PANL"—the air drying black crackle for the amateur, 4s. 6d. per 4 oz. jar, from L. Miller, 8 Kenton Park Crescent, Middx.

VIEWMASTER, exact specified parts at list price by return of post, also Valves and CRT's, stamp for list. James H. Martin and Co., Dept. R.A., BCM/EDHWA, London, W.C.1.

BLUEPRINTS. High Gain 10 Metre Converter, with a de-luxe circuit comprising EF91 RF stage, ECC91 double triode mixer and oscillator, EF92 IF amplifier, with stabilised voltage supply via a 7475. 1s. 8d. post free with full instructions.

REPRINT. Converting the TR1196 Receiver. Full details on converting this unit, which may be purchased quite cheaply, into a very sensitive all-wave receiver. 6d. post free. All the above from A.S.W.P., 57 Maida Vale, London, W.9.

JOIN THE ISWL. Over twenty free services to members including QSL Bureau, Translation, Technical and Identification depts., Dx certificates, contests and activities for the SWL together with over seventy local Groups in this country. Monthly magazine "MONITOR," containing articles of general interest to the SWL and League member. Membership 10s. 6d. per annum. ISWL HQ, 123 Sturla Road, Chatham, Kent.