

A "BABY" SET WITH A LOUD VOICE - Full Details

ADAPTING YOUR SET FOR THE SHORT WAVES

Amateur Wireless

and
Radiovision

Every
Thursday 3^d

Vol. XX. No. 500

Saturday, January 9, 1932



The "BABY"
3

A
"BABY"
WITH
A
LOUD VOICE

The **NEW** **LEWCOS** H.F. CHOKE

(Regd)



PRICE
2/6



Here is something new that will prove a boon to all radio constructors!

As a result of scientific research Lewcos have produced this low-priced H.F. CHOKE, on the same basis as all other Lewcos components—with the best materials by master craftsmen.

Its small size ($2\frac{1}{4}$ " long by $1\frac{1}{8}$ " width by $\frac{1}{2}$ " high) renders it particularly suitable for sets where space is of paramount importance.

A Lewcos H.F. Choke (Type MC) and a 50,000-ohm Spaghetti resistance are specified for the "Baby 3" receiver described in this issue.

LEWCOS RADIO PRODUCTS FOR BETTER RECEPTION

THE LONDON ELECTRIC WIRE COMPANY AND SMITHS LIMITED, CHURCH ROAD, LEYTON, LONDON, E.10

Mention of "Amateur Wireless" to Advertisers will Ensure Prompt Attention

H.L.2

METALISED

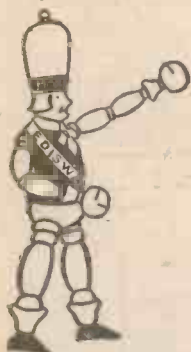

Further evidence of the supremacy of the new range of 2-volt Mazda valves is here in the metalised H.L.2. Extreme sensitivity joins with absolute stability, and its high amplification coupled with a comparatively low impedance renders it particularly efficient as a leaky grid detector or intermediate L.F. amplifier. The steep slope of the H.L.2 also makes it suitable for use as an anode bend detector.

Remember — this valve is a product of Mazda resources — Mazda engineering skill — Mazda research.

THE AMAZING

MAZDA

THE
BRITISH
VALVES

EDISWAN RADIO

ANOTHER
BIG
ACHIEVEMENT
IN THE NEW
MAZDA
2-VOLT
RANGE

MAZDA 2-VOLT RANGE

H.210	- 8/6	P.240	- 13/6
H.L.210	- 8/6	PEN.230	20/0
★ H.L.2	- 8/6	PEN.220	20/0
L.210	- 8/6	PEN.220A	20/0
★ L.2	- 8/6	S.G.215	- 20/0
P.220	- 10/6	★ S.G.215A	20/0
P.220A	- 13/6	★ S.G.215B	20/0

★ METALISED



THE EDISON SWAN ELECTRIC CO. LTD.
RADIO DIVISION:
155 CHARING CROSS ROAD, LONDON, W.C.2

V.144

THE GREAT MOMENT



TUNING IN THE

He spent just an evening assembling his Telsen 3—an evening's easy and delightful work. Now he tunes in for the first time—immediately, in comes the National at full strength—then the Regional—and no overlap! . . . He alters the switch and begins to tour the Continent—in come Hilversum, Berlin, Radio Paris, and half a dozen more—clear, separate, and at full strength . . . And he made the set himself in an evening!

TELSEN 3

Buy your Telsen 3 Kit now and tune in perfect radio to-morrow-night.

Send for illustrated folder of the "Telsen 3" to the Telsen Electric Co., Ltd., Aston, Birmingham.

39⁶/₁₀₀

CVS-133

To Ensure Speedy Delivery, Mention "A.W." to Advertiser



BRITAIN'S LEADING RADIO WEEKLY

FOR CONSTRUCTOR, LISTENER & EXPERIMENTER

EDITOR:
BERNARD E. JONES

TECHNICAL EDITOR:
J. H. REYNER, B.S.C. AM.I.E.E.

RESEARCH CONSULTANT:
W. JAMES.

ASSISTANT EDITOR:
H. CORBISHLEY.

NEWS & GOSSIP OF THE WEEK

"A.W.'s" BIRTHDAY

WE take pride in the fact that this is our 500th issue. It includes many special features which make it of outstanding interest. We want to celebrate our birthday with you!

A special announcement appears on page 49.

A NEW IDEA

THE set described in the middle pages this week is a real novelty. It is a three-valver, with full three-valve performance. Yet it will rest on the palm of your hand! The overall dimensions are only 6 in. by 4½ in. by 4½ in. This "Baby Three" is not a makeshift, and it uses standard components. You will find it well worth investigating.

RADIO PARIS QUALITY

THE Radio Paris sponsored programmes during the past week or so have been of exceptional interest and it is, therefore, a great pity that the quality of the new Radio Paris transmitter does not come up to B.B.C. standard. One reason for the poor tone is the twenty-three-mile-long landline from the studio in the West End to the transmitter at St.-Remy-l'Honore.

GOING BACK

FRENCH listeners are complaining about Radio Paris's quality, too, and while minor changes are being made, the old Clichy station is occasionally used and connected up with the Radio Paris studios. The engineers want reports from British listeners. You should write to the Radio Paris offices at 11 rue François, Paris.

ABOUT THE GOVERNORS

MR. HAROLD G. BROWN takes the place of Sir Gordon Nairne as a Governor of the B.B.C. His appointment is for five years. The chairman, Mr. Whitley, will, of course, continue for another four years. It is significant to note that the other Governors, namely Lord

Gainford, Lady Snowden, and Dr. Montague Rendall, have been re-appointed as Governors for one year only.

COVETED JOBS

THE £700-a-year job of Governor to the B.B.C. is much coveted, as the Prime Minister has good reason to know. He is pressed on all sides by aspirants for B.B.C. honours. The T.U.C. would very much like one of their representatives to be a Governor, and all the Parliamentary parties have nominees. It would, we feel, be a great mistake to appoint anyone with a sectional interest at heart, and that is why we approve the appointment of Mr. Brown, who, although a financial expert of considerable standing, has not as yet been in the public eye. Meanwhile, the Prime Minister has given himself a year's breathing space to think out permanent successors to the re-elected Governors.

TELEVISION HOPES

IN Broadcasting House there will be a studio specially set aside for television

broadcasts—further evidence of the B.B.C.'s changed attitude towards the possibilities of television on an entertainment basis. There is a rumour that the 7-metre transmitter may at some time be used for television tests—no confirmation as yet!

B.B.C. ON THE CONTINENT

THE Continental broadcasting authorities are beginning to wake up to our programmes. Increasing use is being made of the landline cable under the channel, and certain stations show a marked desire to "borrow" our programmes. The Sunday evening symphony concert in Studio 10 on February 21 consists of an all-British programme, with works by Elgar, Delius, Holst, and Ireland. The concert will be relayed to all the chief broadcasting countries in Europe and, of course, will be heard in addition by Regional listeners in England. The line will be the same as that on which we receive Continental relays. The quality is very good.

AN O.B. PLAY STUDIO

A glimpse inside the special radio playstudio inside the Birmingham Repertory Theatre. This has been built by Sir Barry Jackson, in co-operation with the B.B.C., and is complete with sound-damping walls and a red light outside the door.



A WONDERFUL NEW "THREE"—SEE THE ANNOUNCEMENT ON PAGE 49

NEWS & GOSSIP OF THE WEEK —Continued

EMPIRE NEWS TIMES

FOLLOWING our report about the Empire news service in last week's issue, we are now able to give times. G5SW, the experimental short-waver, will be sending out three bulletins every twenty-four hours. The first will be at 12.30 p.m., the second at 6.15 p.m., and the last at 12 midnight.

THE NEW B.B.C. GOVERNOR



Mr. Harold G. Brown, who has been appointed a Governor of the B.B.C., in place of Sir John Gordon Nairne. Mr. Brown is a City solicitor and has been a member of many departmental committees

The bulletins will last fifteen minutes each. In future, G5SW will be open on Saturdays, so Empire broadcasting is really looking up. Now that the Bach cantatas are being stopped, might not the Sunday programmes prove acceptable to our overseas friends?

SPONSORED ITEMS

IT has been found that most of the relay systems working under the Post Office sanction send out to their subscribers foreign items during Sundays, when the B.B.C. is at its dullest or completely silent. Sponsored programmes are now filtering through to many British homes.

ANOTHER LECTURE

THE series of National Lectures proceeds apace, and as they have an interest above that of the ordinary broadcast talk, they are deserving their popularity. Another one is due shortly. Sir F. G. Hopkins, President of the Royal Society, will broadcast a National Lecture on January 22, his subject being "Vitamins as Necessities for Life."

POOR NORTH REGIONAL

WITH the high-power Prague on one side and the new high-power Langenberg on the other side, North Regional

certainly needs all the frequency separation it can get. B.B.C. engineers are closely watching for signs of interference when the Langenberg high-power signals start up. It may be necessary to reduce the separation between North Regional and Prague if severe interference is caused by Langenberg, thus giving a wider separation between the Northern station and the new German station. The most vulnerable area is about forty miles away from Moorside Edge.

IN 1932

BIG events will take place in B.B.C. activities during the coming year; Falkirk will be opened in the early summer; Watchet will probably be finished for the West Regional, the Empire stations will be built at Daventry, the old 5XX plant will make way for a 100-kilowatt station, the Belfast station will be reconstructed as a 15-kilowatt, the 7-metre experiments will be started, and last but not least, the whole staff of the B.B.C. will bid farewell to Savoy Hill to take up new quarters at Broadcasting House. Truly a momentous year in B.B.C. history!

"THE LAST PROGRAMME"

LANCE SIEVEKING is preparing a special retrospect programme to be the last broadcast from the Savoy Hill building. This "last programme" will contain some of the "high spots" of programmes dating as far back as 1923, when the B.B.C. took over offices in 2 Savoy Hill.

TURIN TO BE BETTER

TURIN has been having wavelength and power troubles. Many readers who listen regularly to Turin have commented on the fading and wave-changing. A correspondent informs us that the power is being put up to 15 kilowatts and that a crystal-controlled stage is being built in to keep the wavelength constant. In a month or so Turin should be a useful stand-by for opera lovers.

A COLUMBIA RELAY

ON January 11 the B.B.C. will take over the transatlantic 'phone, an hour's programme compiled by the Columbia broadcasting organisation of America. The relay is timed for 9.15 p.m., and it will be a typical American programme. Paris, Vienna, Budapest, and Prague will also take the relay, although for listeners in these cities the language difficulty will certainly detract from the value of the announcements.

NEGRO SPIRITUALS

ON February 15 Columbia will send us over the

transatlantic 'phone a programme of negro spirituals—in which the Americans certainly excel. To return the compliment, the B.B.C. is arranging some special late programmes to be relayed to America between 11 and 12 at night; dates are not yet fixed, but they will be some time in the early spring. Incidentally, these will supply listeners in this country with an alternative to the late dance programmes.

QUICK-FIRE VAUDEVILLE

ON January 30 listeners will have a real treat—quick-fire vaudeville lasting ninety minutes, with not more than eight minutes for any single turn. Included in the programme are Jack Payne, Ross and Sargent, Wee Georgie Wood, Max Miller, Carr Lynn, the Three Eddies, Leonard Henry, the Hulbert Brothers, the Watson Sisters, the Carlyle Cousins, Jack Collins and others not yet chosen. The B.B.C. is waking up to the need for more and more vaudeville, but the job of finding suitable artistes is as hard as ever.

BRIGHTER AND BRIGHTER!

TO add to its efforts in the vaudeville department, the B.B.C. has decided to present more numerous sketches during 1932. A feature will be burlesques of current films, broadcast to coincide with the general release dates of the films concerned. New ideas for linking up vaudeville turns will be introduced. A male voice choir is one of the suggestions!

PROGRESS AT WEST REGIONAL

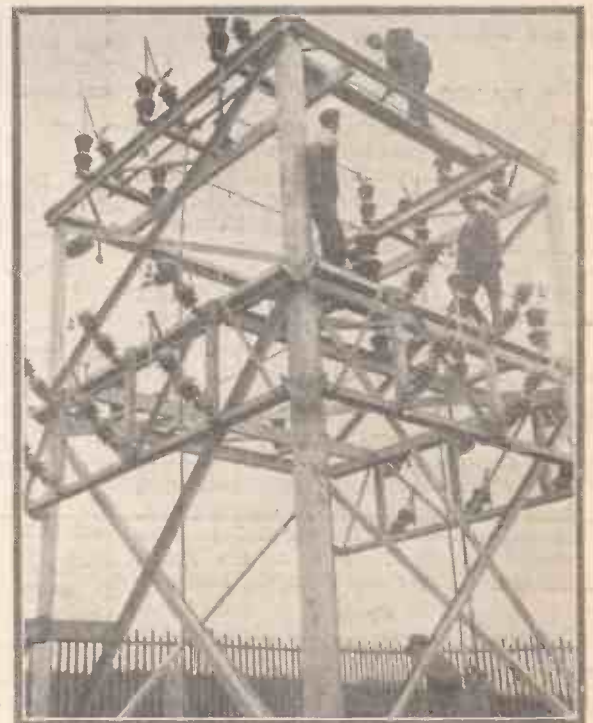

Work has commenced at the new B.B.C. West Regional station near Minehead, Somerset. The engineers are here at work on the 33,000-volt lines which will supply power to the new station

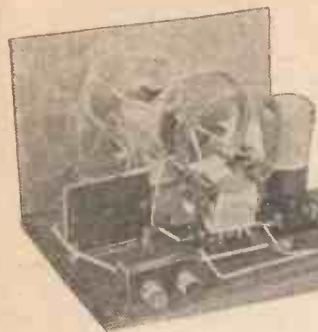

ADAPTING YOUR SET for the SHORT WAVES

All owners of sets that tune only to the medium and long wavelengths will be interested in this practical article by ALAN HUNTER, who shows two simple ways of converting broadcast sets into short-wavers

THERE are two distinct ways of converting a broadcast set into a short-wave set. More exactly, I should say that there is one way of converting the set to short waves and another way of adapting the set—a distinction worth noting.

If the set comprises a detector-and-low-frequency-amplification circuit, it can be adapted to short waves. If the set has one or more stages of high-frequency amplification before the detector, it also can be converted to short waves.

We speak these days of short-wave adaptors for the detector-low-frequency type of sets and of converters for sets with high-frequency amplification.

Two Methods

Although both types of short-wave unit employ only one valve there is a great and fundamental difference in the use made of the set to which the units are attached. There is just this in common—the existing set does not have to be altered in any way when the unit, whether adaptor or converter, is added.

Let us deal firstly with the type of set having a detector with low-frequency

and condensers. The low-frequency part, that is everything after the detector, would be common to the short-wave and broadcast sets.

It is therefore possible to adapt a broadcast set to short waves by altering the tuning and reaction. But as the set is primarily used for broadcast reception, such a plan will not appeal to the average listener. Fortunately, there is a way of enjoying short-wave reception which does not involve any permanent alteration to the existing set.

A Short-wave Adaptor

Fig. 1 shows the way. Here we have the pictorial circuit of a one-valve short-wave adaptor, designed to adapt a normal two- or three-valve broadcast set to short-wave reception. In brief, it consists of a short-wave detector circuit, to take the place of the detector circuit of the existing set.

By arranging the anode and filament connections of the short-wave detector to terminate in a plug, it is quite easy to make use of the battery supply of the existing set when using the unit. This plug takes the place of the detector valve,

circuit will show the reader that it is the simplest possible arrangement of a detector working on the leaky-grid system. The aerial circuit is a 4-turn short-wave coil in series with the aerial and earth. This is known as an aperiodic circuit, because it is almost equally responsive to all incoming signals. It is coupled to the grid-tuning circuit, which is a 6-turn short-wave coil shunted by a .0002-microfarad variable condenser, preferably a low-loss model specially designed for short-wave work.

Reaction is applied to the grid coil by means of another 6-turn short wave coil, arranged so that its winding is only half an inch or so from the grid winding. This reaction coil is in series with a .0002-microfarad reaction condenser which should be similar in construction to the tuning condenser. Both tuning and reaction condensers should be controlled by slow-motion dials.

It is important to note that the moving plates of the reaction condenser are connected to earth, and that the other side of the reaction system, the reaction coil, goes to the anode of the valve. In this anode circuit is a short-wave choke, which serves to divert the high-frequency component of the detector anode current through the reaction system.

Connections

The values of the grid leak and condenser are important. A .0002-microfarad grid condenser is suitable with a 3-megohm grid leak, although it is possible that greater sensitivity would be obtained with a 5-megohm leak.

The filament connections of the valve are taken to the two filament pins of the plug, and the free side of the short-wave choke is taken to the anode pin. It is necessary to look into the filament wiring of the existing set before finally wiring up the filament leads of the adaptor valve to the pins on the plug.

The reason for this will be clear; it is obviously essential that the positive filament connection of the adaptor valve should go to the positive battery connection of the set, and that the negative filament connection of the adaptor valve should go to the negative filament supply. It is easy to see that these two connections might be reversed if the preliminary survey of the set's filament wiring were ignored.

Apart from this precaution, there is nothing in the circuit to cause the slightest bother. If a one-valver is wired up according to Fig. 1 it will adapt, at will, any two or three-valver. I ought to mention that this type of unit can also be used with sets

(Continued on next page)

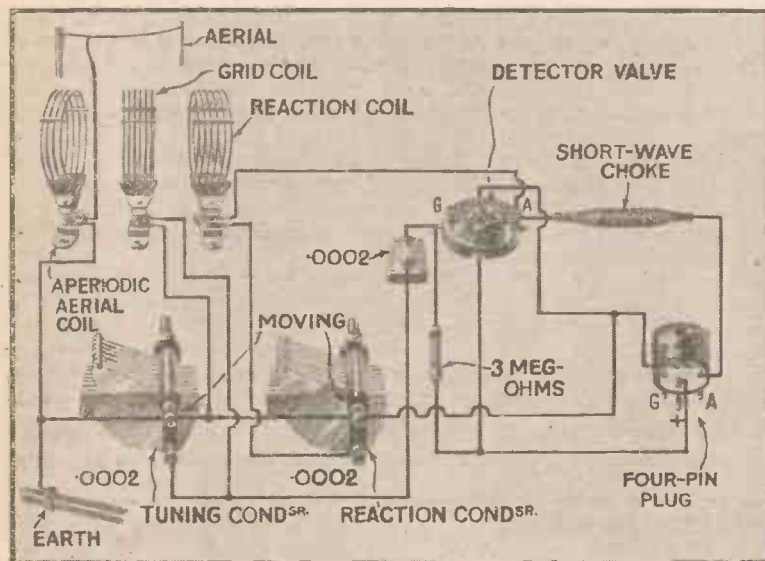

Fig. 1.—This pictorial diagram shows all the connections for a one-valve adaptor suitable for adapting simple two- or three-valve broadcast sets for short wave reception. Note the plug for connection of the adaptor valve to the batteries of the existing set.

amplification, but without high-frequency amplification. What is it that distinguishes such a set from a regular short-waver? Not much more than the tuning and reaction system. In a two-valve broadcast set, for example, there is detector tuning and reaction, with transformer coupling between the detector and output valve. The only difference in a two-valver for short-wave reception would be the size of the tuning and reaction coils

whose battery connections then serve for the extra detector.

A suitable plug can be made from the base of an old valve, but only three of the pins will be needed, namely the anode and filament pins. The grid pin is left unconnected, so that when the adaptor is plugged into the detector socket of the set the grid connection to the set's normal tuning system is broken.

A careful examination of the Fig. 1

"ADAPTING YOUR SET FOR THE SHORT WAVES"

(Continued from preceding page)

having a stage of high-frequency amplification, provided the high-frequency valve is switched off when the adaptor plug is inserted in the detector socket.

There is a disadvantage in such a procedure, as a little thought will clearly show. If a three-valve broadcast set consisting of a high-frequency amplifier, detector, and low-frequency amplifier is adapted with the unit just described, the three-valve broadcast set will be changed into a two-valve short-waver, the two first valves of the set being wasted.

object being to make the detector valve oscillate smoothly.

It will be seen that in the anode circuit of the valve of the Fig. 2 circuit is an arrangement of two high-frequency chokes in series, with a .0002-microfarad coupling condenser connected to the junction of the two chokes. The choke nearer the anode is the short-wave choke, as in Fig. 1, and the other choke is a good-quality long-wave choke. It is most important that the coupling condenser should be connected between the two chokes as shown.

The action of the circuit is not very difficult—and its operation is extremely simple. The unit valve is brought into a

high-frequency amplifier, detector, and low-frequency amplifier (all in the existing set).

The Fig. 2 pictorial diagram gives all the essential values of the short-wave unit for super-het conversion, and it will be noted that the tuning and reaction circuits of the adaptor and converter units are similar.

In operation the converter unit is the essence of simplicity. The aerial and earth leads of the existing set are taken to the aerial and earth terminals of the converter, which is connected to the set by joining the free end of the coupling condenser to the aerial terminal of the set.

If the set is battery-operated, the existing batteries will do to operate the extra valve. Simply connect the high-tension positive lead from the converter to about 60 volts, and the two low-tension leads to the accumulator. Should the set be mains operated it is probably cheapest to buy a 60-volt standard-capacity high-tension battery and a small two-volt accumulator, using these as a separate source of supply. I myself have adopted this way, coupling a one-valve battery-operated converter to my four-valve A.C. set.

Operating Notes

There is just one point about the operation of the converter that needs explaining; when operated it will appear that short-wave signals are being accurately tuned in, whereas actually they will be slightly mistuned. The slight difference in the frequency of the local oscillator and the incoming frequency is essential to obtain the super-het action. As a rule, the set should be tuned to about 1,800 metres for the most sensitive results. This long-wave setting of the set is not very critical, and results are possible from about 1,600 metres to 2,000 metres.

Just one more point; the reaction control of the converter must be adjusted so that, during reception, the valve is in a state of oscillation. The tuning and reaction of the set need not be touched once a suitable long wave has been found, and the set has been brought to a suitable state of sensitiveness. For the reception of C.W. morse signals it is necessary to introduce reaction into the second detector, as by increasing to the point of oscillation the reaction control of the set.

Where the set is one with a stage of high-frequency amplification, there is not much doubt about which type of short-wave unit to use—go in for a super-het converter; but for the simpler sets, without high-frequency amplification, the adaptor type of unit is most effective.

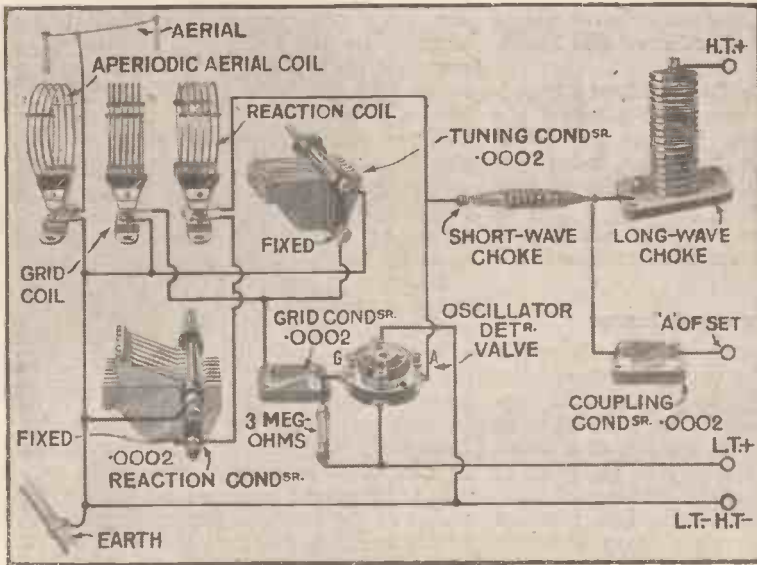

Fig. 2. In this pictorial diagram are shown all the connections needed for a one-valve unit to convert a broadcast set with a stage of high-frequency amplification into a short-wave super-het. Note that the unit is connected to the set through a .0002 microfarad coupling condenser

There is a very much more effective way of utilising a three-valver with a stage of high-frequency amplification for short-wave reception—by means of a converter unit, built around the circuit shown in pictorial form by Fig. 2. Here we have a one-valve circuit arranged to act as an autodyne detector in a super-heterodyne sequence.

The Super-het Principle

With this type of unit there is one stipulation—the existing set must have a stage of high-frequency amplification. A three-valver with the popular sequence of high-frequency amplifier, detector, and low-frequency amplifier could, with the Fig. 2 unit, be converted into a four-valve super-het for short waves. Similar tuning and reaction values will serve for the Fig. 2 circuit as for the Fig. 1 circuit, the main

state of gentle oscillation and the tuning is adjusted to a frequency slightly different from the frequency of the incoming short-wave signal. The local oscillation beats with the incoming oscillation to produce a new frequency which corresponds to a long wavelength.

The short-wave choke diverts the incoming short-wave signal back through the reaction system, but allows the much lower frequency of the beat oscillation to pass on to the coupling condenser, which offers an easier path to the supersonic signal than the long-wave choke, so signals are passed on through the coupling condenser to the first of the set's valves, which must be a high-frequency amplifier, tuned to a long wavelength.

The complete short-wave sequence is therefore as follows: autodyne detector-oscillator (in converter unit), intermediate

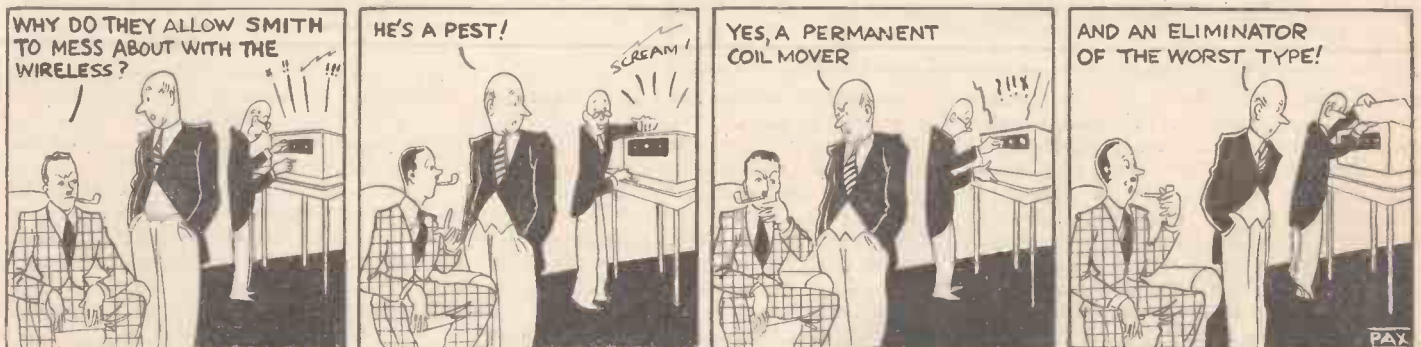



CHRISTOPHER STONE ON MY GRAMOPHONE BROADCASTS

In an interview with Kenneth Ullyett he gives some interesting facts about these popular broadcasts

"YES, I still have to wind up the gramophone when I broadcast," said Christopher Stone, when I saw him last week immediately after he returned from a Radio Paris broadcast.

"As a matter of fact, I have to wind up two gramophones," he explained. "The special console in one of the Studios at Savoy Hill has two turntables with a reading desk between. The microphone hangs above this. While one record is playing, I am preparing notes for the next record, and changing the needle and winding the turntable in readiness. The B.B.C. engineers have so far insisted that spring-driven gramophone motors be used, because they say that electric motors cause interference with the pick-up. That is why I still have to wind up before each record and, yes, I admit it, that is why a record sometimes runs down in the middle!"

"But I suppose things will be better in Broadcasting House?" I asked.

The New Machines

"I haven't seen the new studio yet," he said. "From all accounts, it should be a most satisfactory arrangement with electrically driven turntables and with satisfactory arrangements for 'fading' from one record to another.

"For quite a long while I had to use an ordinary change-over switch in Savoy Hill broadcasts. The engineers explained how much difficulty there was in fitting a potentiometer-type fader which would be quite immune from interference. However, for two or three special occasions, they did improvise a fader."

Radio Paris Broadcasts

"What about Continental broadcasts?" I inquired.

"I have only just come back from Paris after my Radio Paris broadcasts during the holidays," he said. "That is the first time I have been to Radio Paris and spoken from the studio. My previous broadcasts have been done, as you know, with gramophone records. I pick out the records I want for each recital and, in the Decca studio, make a special record introducing each. That is fairly convenient for me. It saves me going to Paris each week-end. But it must raise a number of difficulties at the studio end, for the announcer has to put on a little of my record, and then the record to be played. All is well so long as none gets out of place.

"From the listener's point of view, the system I adopt with B.B.C. broadcasts is probably the most satisfactory. I take

my own records to the studio, broadcast, and bring them back again. This is necessary because many of the records are special ones, and, as listeners know, in my programmes of new releases I often give records a day or two before they are available. Although I understand that the B.B.C. has an immense library of about 5,000 records, they are none of them mine! As London editor of *The Gramophone*, I have quite enough to do with records without pining for the B.B.C. library."

Preparing the Programmes

"I suppose you often have to prepare your B.B.C. programmes in a hurry?" I commented, knowing that many of Mr. Stone's little speeches and witticisms between record broadcasts are impromptu.

"Sometimes in very much of a hurry," he agreed. "That is when the difficulties crop up. I have no orders from the B.B.C. to keep any special proportion in the record programmes, but I do try not only to broadcast an equal number of records of all kinds, but also, in fairness to the manufacturers, to keep an equal proportion among the makes.

"I hear all records before they are broadcast. Generally speaking, I choose those which I think will appeal to each class of listener. In certain instances, such as the broadcasts of 'hot' American dance records, I am guided by Mr. Edgar Jackson, a specialist in that kind of thing.

"People who like these American records write and express disgust at the time I give to more serious records. Musicians who are not dance fans express their disapproval of the 'hot' style rhythm records!"

The Post Bag

"I get, on an average, eighty letters a week, most of which need answering. Considering the fact that I give about twenty records a week and that a remarkably small time is given in B.B.C. programmes to gramophone broadcasts, I think you will agree that this is an extraordinary post bag. I choose my record programmes according to listeners' de-

mands. Some letters involve a lot of work since many of them ask for catalogues, makers of records, or lists of records, or for advice about buying gramophones and radio-grams. Probably other broadcasting people get far more letters to answer, but I doubt if they get more formidable ones!"

THE CATHODOPHONE

THE Cathodophone is a form of microphone utilising the principle of electron emission, instead of the varying resistance of carbon particles, to convert sounds into equivalent electric currents. A number of incandescent filaments are arranged in close proximity to a diaphragm. As the



One of the new gramophone broadcast consoles of the type used at Savoy Hill

latter vibrates under the impact of the sound waves, its distance from the heated filaments varies, and the value of the electronic stream passing across the intervening space, rises or falls accordingly. The microphonic currents so produced are exceptionally free from ordinary distortion, but are accompanied by a slight "hiss," due to the heated filaments, which is somewhat difficult to eradicate. M. B.

In Basle, Berne, Geneva, Lausanne, and Zurich, the Swiss telephone authorities have installed a new wired-wireless system for their subscribers. For this service the organisers claim freedom of interference and perfect reception of the local transmissions through special loud-speakers installed at a small cost.



CHOOSING A MOTOR FOR YOUR RADIO-GRAM

THE progressive amateur invariably, and rightly so, prefers an electric motor to one of the spring-driven type, but when he sets out to buy, is confronted with a large number of makes and types and a wide range of prices.

Strictly, there are three broad classes of electric motor on the market, viz., commutator, induction, and synchronous, but before considering their respective merits it is necessary to know something of the various conditions which an electric gramophone motor must fulfill.

Playing Speed

The first and most obvious requirement is that it must rotate the turntable at the correct speed, with perfect regularity under all conditions. It must not pull up on heavy notes or passages in records, causing that distressing "flattening," commonly caused by weak motors, nor must it speed up as the pick-up approaches the centre of the record, where less driving power is necessary.

There must be no trace of irregular running when long-sustained notes are being played, and solo instruments, such as piano or bells, must be rendered clear and distinct without any trace of tremolo or "dither."

The playing speed should not be affected by fluctuations in the supply voltage and the motor should, preferably, have sufficient reserve of power to enable it to be used for recording purposes.

It will be readily understood that to cut a record calls for a greater turning effort than merely to play one.

For accurate reproduction, records should be played at the speed at which the original was made and this is always marked on the record. The standard mostly used in this country is 78 r.p.m. for ordinary 10- and 12-in. discs; 16-in. discs used for talkie work usually run at 33½ r.p.m.

It is obvious that the notes of a record played fast or slow will be of incorrect pitch. Nevertheless many gramophone users prefer to run fast, particularly with dance records, so that the normal speed should be variable over a fair range, say from 70 to 90 r.p.m.

It should be clearly understood that a motor set for, say 85 r.p.m., must keep this speed right through the record.

The motor must be silent in running. This is most important, as to hear the noise of the motor is most annoying and detracts from the efficiency of the instrument.

For loud records or dance music a little extra motor noise does not usually matter. Generally speaking, the slower the mov-

Too much care cannot be taken over the choice of a suitable turntable motor for one's radio-gramophone, for the performance of the gramophone side entirely depends on it.

ing parts of the motor, the quieter it will be, although much depends on the degree of perfection attained in the construction of the motor. Thus there are slow-running motors which are noisy and fast-running ones which are surprisingly quiet.

The motor should not heat up excessively when run for a long period without stopping. It should be remembered, however, that all electric motors become warm in working and due allowance should be made for this fact. Normal heat is not detrimental to the motor. All other things being equal, however, a cool motor is preferable to one which runs hot, because there is less likelihood of deterioration of the insulation and drying up of the oil.

Interference

Another important point, and one where quite a number of motors fail, is that it must not cause interference with the pick-up.

A good motor, provided the pick-up leads are kept a reasonable distance away from it, should not require any shielding or earthing to prevent its running being heard in the loud-speaker.

It may be mentioned here that motors having commutators and brush gear are the greatest offenders in this respect. Their use, however, is inevitable where the supply is direct current, but they can be conveniently avoided in the case of A.C. supplies.

The current consumption of all types of electric gramophone motor is so small as not to warrant any consideration so far as cost of running is concerned. A motor taking 20 watts will run fifty hours for the cost of 1 unit of electricity, and assuming a record takes four minutes to play, this represents no less than 750 records for a penny or so.

The accessories supplied with the motor must be taken into account in comparing

the various machines. Some makers fit the motor and its accessories on what they term a motor plate, and all one has to do is to cut a hole in the cabinet, drop the motor in, and connect up. Other motors are supplied with a miscellaneous collection of loose parts, each of which has to be fitted separately on the board.

Again one has considerable choice in the matter of stopping switches, of which there are three broad types: the plain switch, which is put on and off by the operator; the semi-automatic stop, which stops the motor at the end of the record, but has to be previously set by placing the needle in the last playing groove; and the fully automatic stopping switch, which stops the motor at the end of any and every record without any previous setting. Needless to say the last is much to be preferred and is, in fact, supplied as a standard fitting with most of the leading makes of electric gramophone motors.

The means of lubrication is a point to look for, and its importance or otherwise depends upon whether the motor will be accessible or not when the instrument is completed.

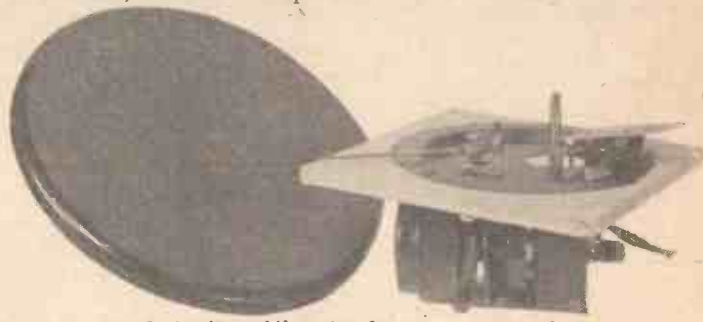

A "universal" motor for separate assembly

In some makes of motor all the oiling is done through the turntable spindle, which is purposely made hollow; in others the turntable has to be removed to effect the lubrication, and again it is often necessary to oil each bearing separately, no provision being made for central lubrication.

Turning now to the various types of motor. As mentioned above, there are three, the commutator or universal type, the induction, and the synchronous.

Universal motors will work on alternating or direct current. Generally, they are only used where the supply is D.C. and, owing to their liability to spark, either when new or after having been in service

(Continued on page 72)

Mullard Valves are the choice of the designer of the 1932 *Ether Searcher*

P.M.12

The Mullard 2-volt Screened
Grid Valve for the H.F.
stage. Price 20/-

P.M.1HL

The Mullard 2-volt
detector. Price 8/6

P.M.22

The 2-volt Pentode for
the output stage.
Price 20/-

● of course there's a reason for the choice; a
good reason: the reason for Mullard popularity
everywhere. It is consistently sound performance.

**MULLARD VALVES ARE
MADE IN ENGLAND**

Mullard

THE • MASTER • VALVE

TELSEN

THE SECRET OF PERFECT
RADIO RECEPTION



NEARER . . .
CLEARER . . .
MORE LIVELY
THAN BEFORE

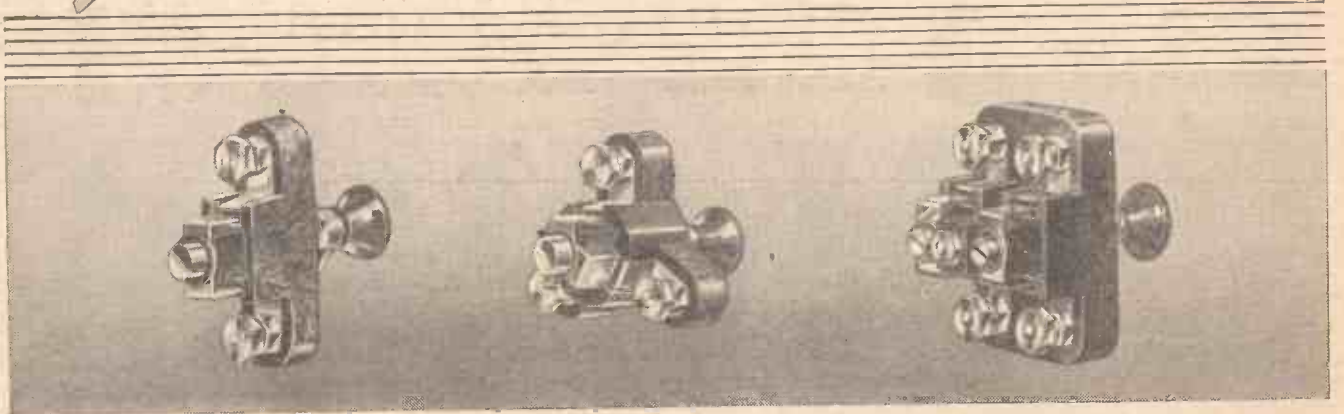

To Ensure Speedy Delivery, Mention "A.W." to Advertisers

“CHANGING over to Telsen is like taking the wool out of your ears”—that is the verdict of an enthusiastic Telsen constructor which inspired the illustration on the opposite page. Telsen Components in your set give you a realism which is astonishing—they enable you to sit back and hear, without straining forward to listen—they bring every item on the programme “nearer, clearer, more lively than before.”

- TELSEN DUAL-RANGE AERIAL COIL 7/6
- H.F. TRANSFORMER AND AERIAL COIL 5/6
- LOGARITHMIC VARIABLE CONDENSER
In capacities .0005, .00035, .00025 .. 4/6
- BAKELITE DIELECTRIC DIFFERENTIAL
REACTION AND TUNING CONDENSERS
in all capacities from 2/-
- PRE-SET CONDENSERS 1/6
- MANSBRIDGE TYPE CONDENSERS From 1/6
- FIXED CONDENSERS (Prov. Pat. No. 20287/30) 6d.
- PUSH-PULL SWITCHES (Prov. Pat. No. 14125/31)
- Two-point 1/-
- Three-point 1/3
- Four-point (2 pole) 1/6

TELSEN

100% BRITISH
RADIO COMPONENTS

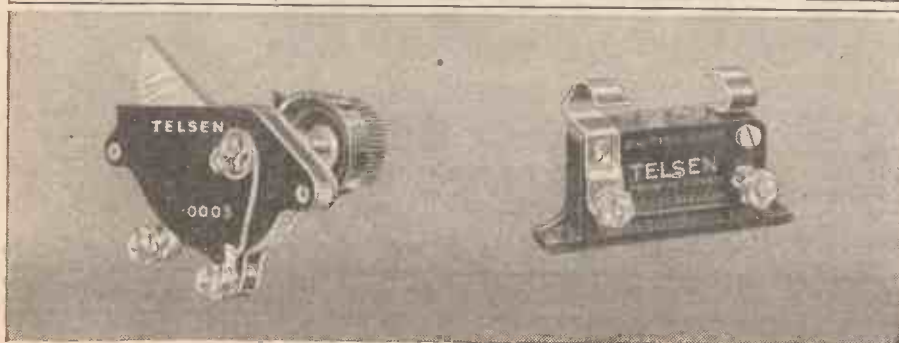
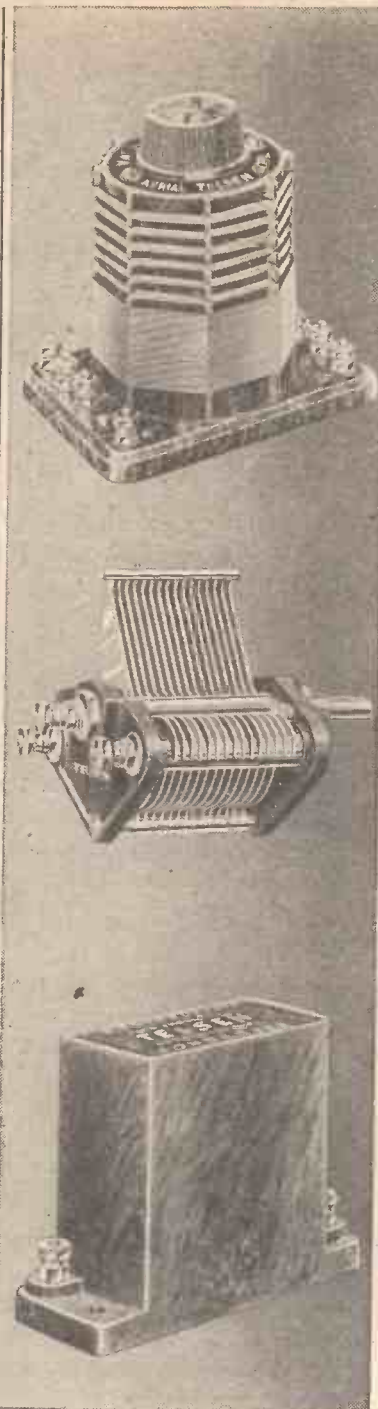

Advt. of The Telsen Electric Co., Ltd., Aston, Birmingham.

CVS-125

You will Help Yourself and Help Us by Mentioning "A.W." to Advertisers

SELECTIVITY—

to-day's great Radio problem

Station Overlap is often due to the use of inefficient and out-of-date Screened Grid Valves

THE separation of programmes is growing more difficult. Stations are daily increasing their power — Prague now radiates 200 kw., Warsaw 158 kw., Muhlacker 75 k.w.—all adding to the problem of preventing "station overlap."

Your Receiver cannot bring you crisp, clear cut programmes unless it is really selective. And its selectivity will be poor if its Screened Grid Valve (or Valves) is inefficient or out-of-date. The S.G. Valve has a big influence on selectivity.

Because of their special design, their record low inter-electrode capacity (of the order of .001 m.m.f.) and unique Mica Bridge Construction Cossor S.G. Valves are exceptionally efficient. Their use ensures a marked improvement in the performance and selectivity of any Screened Grid Receiver.



NATIONAL

REGIONAL

COSSOR

ALL-BRITISH
SCREENED GRID
VALVES



A copy of the 72-page Cossor Wireless Book B11 will be sent you free on application to A. C. Cossor Ltd., Melody Dept., Highbury Grove, London, N.5.

A new edition of the Cossor Station Chart is now available, price 2d. Ask your Dealer for a copy of this useful novelty, or write us enclosing 2d. stamp.

THE VALVES WITH THE MICA BRIDGE CONSTRUCTION

A.C. Cossor, Ltd., Highbury Grove, London, N.5.

9030

Please Mention "A.W." When Corresponding with Advertisers

On Low Wavelength!

MUCH ADO ABOUT NOTHING

THERE was quite a flutter in wireless dovecotes the other day when one of the lay dailies came out with the statement (complete with scare headlines) that the Post Office was about to take over all of the wireless relay concerns operating in this country. The facts appeared, on the face of it, to be well authenticated, for it was stated in black and white that the relay companies had received notice that their systems would be taken over by the Post Office at the end of this year. The whole thing turned out to be absolute nonsense. The Post Office always reserves the right to take over any business in any way connected with telephone or telegraph transmissions, but there is not the slightest likelihood of its swallowing the wireless relay services in the immediate future.

AN IMPRACTICABLE SCHEME

THE idea sketched by the lay paper was that any householder on the telephone who liked to subscribe would be provided with a wall plug into which he could fit a loud-speaker. If he wanted to hear wireless he would ring up exchange, ask what programmes were going, make his choice, and request to be put through. He would then plug in his loud-speaker and receive the required broadcast. One obvious flaw suggests itself at once to anybody who knows anything about the telephone system. The telephone is designed simply for reproducing intelligible speech. This can be done by the use of a remarkably small range of frequencies. Hence both the instruments and the lines which serve them will deal with only a narrow band of frequencies in the middle register. A tremendous amount of work and a great deal of money would be involved in rendering telephone lines fit to reproduce music without distortion.

BADLY NEEDED

WHAT do makers of valves always give us the mutual conductance figures of valves based on zero grid volts? As I shall show you in a moment, there is very little to be said for this system and a great deal to be said against it. The mutual conductance is what we may call the efficiency factor of a valve. Actually, it is the change in plate current brought by a given change in grid volts, and clearly the more efficient a valve is, the bigger will be the alteration in its plate current produced by a given variation of the grid voltage. But hardly any valve nowadays is used with its grid at zero. On the H.F. side suitable negative grid bias improves selectivity besides making for economy and increased service life of valves and batteries. On the L.F. side, we must use grid bias if we are to avoid distortion. What I suggest is that mutual conductance

should continue to be taken with 100 volts on the plate, but that the grid bias should be the amount recommended by the makers for use with this plate current.

AN ABSURD POSITION

YOU will see how ridiculous it is to give the mutual conductance figures with the grid at zero if you look at the curves of super-power valves. If their grids are made zero the plate current often exceeds the maximum amount permissible, and the makers issue a special warning that alterations in the grid bias should never be made unless the H.T. is switched off. This, in other words, amounts to telling you that you must never set the grid at zero volts, or you will probably ruin the valve. Comparatively few people, again, have milliammeters capable of dealing with the enormous plate current passed by some super-power valves with their grids at zero and 100 volts on the plate. Some time ago I battled for the publication by makers of plate volts, plate current curves, and many of them are now giving us these. Will they please hearken also to this plea for mutual conductance figures taken under something like normal operating voltages?

A DISAPPOINTMENT

MOST listeners were bitterly disappointed that the programme of Christmas greetings from all parts of the Empire had to be declared off at the last moment. The B.B.C. announces that it is not cancelled, but merely postponed—not till next Christmas, I hope! The idea was to take us, by means of the beam telephone service, to various parts of the Empire for chats between an announcer sitting in London and dwellers in far corners of the world to be relayed. It was a jolly good scheme, and I do hope that we shall have it later on.

GOOD HOLIDAY CONDITIONS

ONE great thing about the Christmas and New Year holiday period was the extraordinarily good conditions for foreign reception which prevailed the whole time. There have been good winter seasons in the past, but I am quite sure that we have never had better reception than during the present one. If you cast your mind back a little you will realise what an enormous improvement has been made in the reception of foreign stations. Nowadays there are many which, with a good high-frequency amplifying stage, are so powerful that it is a case of using the volume control rather than the reaction knob. The quality with which they come through is absolutely first-rate; in fact, it is not the least exaggeration to say that with a decent set you can receive many foreigners nowadays every bit as well as your local station.

In the old days, when low power was the general rule, we had to make a great deal of use of reaction; we worked, in fact, much too close to the point of oscillation, and the quality was therefore bound to suffer. The great thing in long-distance work, if you want to obtain genuine entertainment from abroad, is to find out the limitations of your set and to confine yourself mainly to those stations which it will bring in without any pressing. Matters are, of course, quite different when you are taking an occasional run round Europe to see how many stations you can bag. Quality then is a secondary consideration, quantity being the first.

ALL GOOD BOYS

IN past years I have always rather dreaded the approach of the Christmas season in one way. New sets were everywhere; crystallisers had become valve-ites; single-valve-ites had become multis. Everybody was trying out his new set, and from morning to midnight the ether was filled with howls and screams and whistles and catcalls. On several occasions in past years I have had to give up reception of even the local station as a bad job owing to this kind of thing. But now all wireless folk seem to be good boys—or good girls. I won't say that I didn't hear occasional squeaks from Ham-Handed Harry (or Harriet), Oscillating Oswald (or Olive), but they were very few and far between.

THE TROUBLES OF THE DESIGNER

THE way of the designer of wireless sets is a hard one nowadays. I want to tell you something about our adventures and then I am sure that you will extend us your deepest sympathy. You decide, let us say, to turn out the very last word in 'three-valvers'. After a great deal of work you arrive at a circuit which really is "the goods," and then you proceed to make your final model. This needs a great deal of planning, for the design must be such that it is neat, compact, and easy for the home-constructor to put together. You have received from the makers a simple three-gang condenser which strikes you as a beautiful component. It will just fit in, and you design your whole set round it. Several other attractive components also fit like the pieces of a jig-saw puzzle into the places that you provide for them. You admire your finished handiwork. You test it out and find that it is even better than you had hoped for.

A HARD PATH

AND then the fun (or, rather, just the opposite) begins. You find, on making inquiries, that there has been such a run on that particular three-gang variable condenser that deliveries cannot be guaranteed. Sighing, but

On Your Wavelength! (continued)

still undaunted, you alter the design to take in another type. This time deliveries are said to be certain. But no sooner have you finished the set than you hear that a huge demand for the second condenser has resulted in all stocks being sold out. And so it is with other components. Will you believe me when I say that recently I had to change the "potted" coils of one set twice over, the ganged tuning condenser as often, and various other components several times before the design could be published with anything like certainty that the components would be available. And that is not all. Sometimes, after all your trouble, the run on a particular component occurs between the finishing of a design and its publication. And then exasperated readers bombard you with polite curses because they cannot buy the recommended parts. Somehow, one thinks of the notice that used to appear in Wild Western saloons: "Don't shoot the pianist; he is doing his best."

THE MOST POPULAR SET

HERE is no doubt that the three-valver is the most popular set nowadays in one of its two possible forms. For loud-speaker work you can arrange your valves H.F., Det., L.F., or Det., L.F., L.F. The first arrangement is the more effective all round, for a high-frequency stage has big advantages. It automatically increases selectivity; it adds greatly to the range of the set; it enables numerous stations to be brought in with no more than a whiff of reaction. But, unfortunately, a high-frequency stage is a good deal more expensive to make than a low-frequency amplifier. It means, you see, an extra tuning condenser, an extra dual-range coil, and so on. The expense is further increased if you want to make your H.F. side a one-knob tuning affair, for then you have to provide a two- or three-ganged condenser. If, therefore, you want an economical set to build I would recommend you to go for the one containing a detector and two L.F. stages. This can be produced at a surprisingly low figure, for, owing to the huge advances made in L.F. transformer design, minute components are now made which cost but a few shillings, though responding perfectly to an enormous range of speech and musical frequencies. It is wonderful, too, what you can do in the way of foreign reception with a detector and two L.F. set.

ELECTROLYTIC CONDENSERS

WONDER whether we shall all be using electrolytic condensers in a short time. Many people put forward this suggestion very seriously. In the first place, one can obtain more microfarads in a given space, and even today the price is of the same order, and in some cases cheaper than the equivalent paper type. One of the most striking demonstrations of the compression of microfarads into a small space was shown to me the other day. I picked up a small

condenser which I thought was a .01 microfarad. Something about the marking seemed a little curious, so I looked at it again, and found that it was 10 microfarads! I could hardly believe my eyes: 10 microfarads in the same space as an ordinary .01 mica condenser!

NEW TYPES

THE condenser was designed for grid-bias purposes, and would not stand more than 40 volts, but this was quite adequate. The condenser, of course, was of the dry type, containing no liquid, and was, therefore, unspillable and could be handled with the same ease as an ordinary condenser. For mains work we have the somewhat larger type, giving us 8 or 10 microfarads in a can about 1½ in. diameter and 4 in. high. This is distinctly smaller than the equivalent paper condenser, for most of these electrolytic condensers intended for mains working are tested at 400 volts, and there is every indication that we shall get the size down still smaller before long. The one snag with an electrolytic condenser is that it must not be connected the wrong way round, and, of course, cannot be used on A.C. Their use is therefore limited, but within these limits they may quite easily come into very general favour.

ON 7 METRES

IT is rather too early to think of sets for 7-metre reception, but I expect many amateurs are looking forward with keen interest to a participation in the B.B.C.'s test transmissions to be radiated from the top of Broadcasting House. I see that the Chief Engineer hopes to be able to make a start on this 7-metre stunt by April or May of this year. For some months, I expect, there will be absolutely nothing doing for the amateur, for the B.B.C. will no doubt pursue a "hush-hush" policy until definite data of field strengths in and around London has been accumulated and sifted.

When you come to think of it, this 7-metre business is the most experimental undertaking yet associated with the B.B.C. The regional stations were not experimental,

although listeners were asked to consider them as such during the initial try-out period. But the B.B.C. really is in the dark about the possibilities of its 7-metre transmitter, so I do not expect the engineers will say much for quite a while.

All the same, when it is known that signals are being sent out from the aerial on top of Broadcasting House there is nothing to prevent the enthusiast from attempting to pick them up. Only those in the immediate vicinity of Portland Place have much hope of hearing anything, since the maximum range of 7-metre signals is said to be ten miles.

LAND-LINE RELAYS

IF you tune in your set to Continental stations on Sundays you must be impressed with the number of programmes sponsored by English firms, and announced in English for the benefit of listeners in this country. From Radio Paris last Sunday I heard two personalities well known at Savoy Hill, both connected with programmes specially prepared for our reception. I must admit I was greatly entertained with the programmes so gratuitously offered, but I understand the B.B.C. is not a little perturbed by the growing number of these foreign Sunday attractions, which make its own fare seem even duller than it actually is.

Of course, it is not the concern of the B.B.C. that listeners with powerful sets tune in stations on the Continent in preference to the home stations; but there is another type of listener, not blessed with the means of getting into direct touch with the Continent, who is rapidly becoming accustomed to Sunday programmes from abroad, namely the subscriber to one or other of the numerous land-line relay systems.

These systems work under a permit from the Post Office, and although it is expressly forbidden to originate matter at the central receiving station, there is no stipulation regarding the relaying of foreign stations. It appears that many of these systems, which are run by keen men with eyes on public demand, are ignoring the B.B.C.'s Sunday programmes entirely, and relaying Radio Paris and other stations of real entertainment value.

The B.B.C. has only itself to blame for this state of affairs. It has resolutely refused to what it calls "secularise" the Sunday programmes, with the result that the "high-spot" of an average B.B.C. programme on Sunday is a military-band concert or a seaside orchestra. I know many listeners with simple sets, incapable of getting on to the foreigners, who count Sunday as entirely lost so far as broadcast reception is concerned. Which is a very sad state of affairs, is it not?

THERMION.

Breslau, Heilsberg, and Langenberg, according to a rota, regularly relay U.S.A. programmes three times weekly between 8 and 9 p.m. G.M.T.

CHOOSING A DETECTOR

Always be sure of figures when buying a new valve. Average values for a good

DETECTOR	
A	15,000-20,000Ω
B	1.4
C	20-25



detector are shown here. A is the impedance, B the mutual conductance, and C the amplification factor.

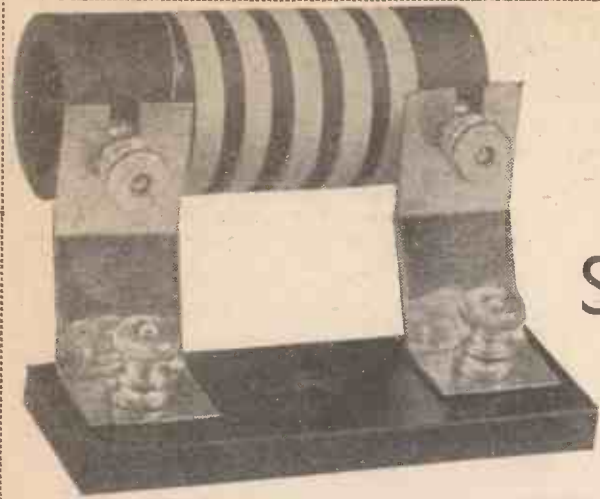

HOW TO MAKE YOUR OWN SHORT-WAVE CHOKES

Practical details of an easy method of construction

HIGH-FREQUENCY chokes for short-wave receivers are among the easiest of all radio components to make at home. The winding is a quick, straightforward job, as the number of turns of wire required in a choke for short-wave work is comparatively small, and they are put on in a single layer.

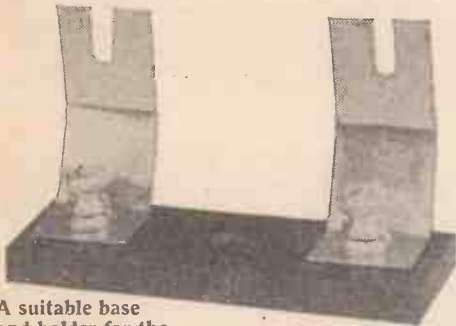

A suitable base and holder for the short-wave chokes

The necessary materials can be purchased very cheaply, and in many cases the cost can be reduced still further by making use of odds and ends that are already at hand.

As these chokes can be made so quickly, cheaply, and easily, it is worth while constructing several, with different types of windings, and arranging them so as to be readily interchangeable. Some interesting experiments can then be made to ascertain the best type of choke for different wavebands with any particular circuit. The illustrations to this article show some interchangeable short-wave chokes of simple design that will give very good results. Each choke is made by winding a number of turns of fine-gauge insulated wire on to a small-diameter ebonite tube, and connecting the ends of the windings to a pair of terminals mounted on the tube. These terminals engage with slotted metal clips mounted on a small ebonite base or holder which is screwed to the baseboard of the set.

The necessary materials are as follows:—

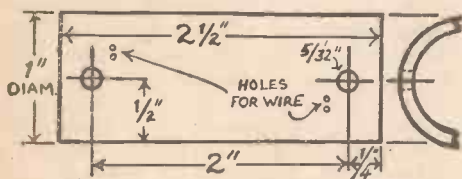

Fig. 1. Details of ebonite former

For each choke, an ebonite tube 2 1/2 in. long, having an external diameter of not more than 1 in., and an inside diameter of, say, 3/4-in.; 2 4B.A. terminals; a small quantity of 32-40 S.W.G. enamelled or silk-covered wire. For the holder, an ebonite slip 3 in. by 1 in. by 1/4-in.; 2 4B.A. terminals; 2 strips of brass, say, 2 in. long by 1/2-in. wide.

Sufficient ebonite tubing to make six formers costs about 2s. If bought in a piece it can be cut up into the required lengths neatly and easily with a hack-saw. The total cost of the materials for each choke works out at about eightpence—while the holder costs about sixpence.

Simple Construction

The ebonite former for each choke is drilled as shown in Fig. 1. A number of turns of the insulated copper wire are then wound on in a single layer. The wire is best put on under moderate tension, as this helps to ensure that the turns lie neatly and evenly together.

The winding may comprise, say, from fifty to one hundred turns, and may be either plain or sectionalised. A typical arrangement might consist of a winding comprising five sections, each section containing 20 turns, thus making 100 turns in all.

On completion of the winding, the ends of the wire are bared and connected to the pair of 4B.A. terminals which are inserted in the holes drilled to receive them near the ends of the ebonite tube. As the wire used is rather fine, it is not advisable to scrape off the insulation with a pen-knife since this is almost certain to result in

damage or breakage. A much better way of baring the ends of the wire is to rub off the silk or enamel covering very gently with a slip of sandpaper.

The connections can be either soldered or clamped between washers under the heads of the terminal-screws. The choke is then complete and ready for use.

Making a Holder

A base or holder for the chokes is made by drilling the ebonite slip as shown in Fig. 2, and mounting on it two slotted clips or brackets. The latter are formed by cutting, drilling, and bending the small brass strips as shown in Fig. 3. These clips are secured to the ebonite base by clamping them under



One of the complete chokes with terminal connections

the collars of two 4B.A. terminals. The heads of the terminal-screws should be recessed a little on the underside of the ebonite so that they clear the surface of the baseboard when the holder is screwed into position in the set.

A single fixing screw passed through the central hole in the ebonite base serves to secure it to the baseboard of the set. This screw should be driven well home to prevent the holder moving when the chokes are inserted or withdrawn.

Fig. 4 shows a side view of the holder with a choke in position. The heads of the terminal-screws are recessed into the ebonite tube. (Continued at foot of next page)

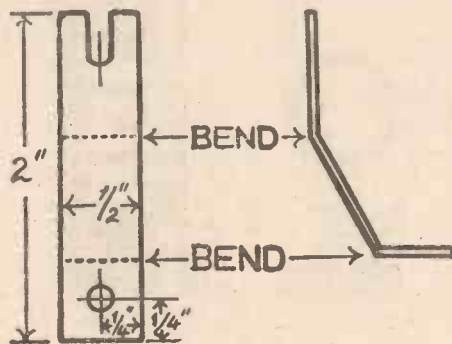

Fig. 3. Brass supports for mounting

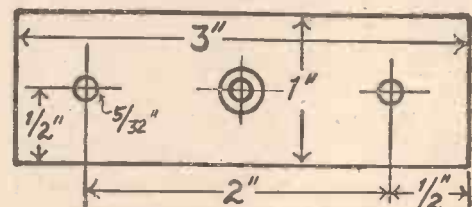

Fig. 2. Details of base

1931—THE YEAR'S BROADCASTING

A record of B.B.C. progress and of the outstanding broadcasts of the year.

ALTHOUGH programmes have reached a consistently high level during the past year, the most notable fact about British broadcasting has undoubtedly been constructional development. This has culminated in the completion of Broadcasting House, London.

The work on the new headquarters at Broadcasting House has proceeded throughout the year and a large part of the office accommodation was taken over on September 28, 1931. The control room equipment has also been installed and the acoustical treatment for the studios has been specified. The decoration is at present in hand.

Constructional work at the North Regional station was completed during the early part of last year. Following public reception tests, the Regional transmitter took over the service on May 17 and the full service of alternative programmes was introduced from this station on July 12, 1931. Constructional work on the Scottish Regional station has continued. The building is now completed, the installation of plant is in hand, and it is expected that tests will begin in the early summer. After lengthy tests, a suitable site for the West Regional station has been purchased at Washford Cross, near Watchet, Somersetshire. Constructional work will begin immediately.

On November 6 the B.B.C. announced its intention of proceeding immediately with the erection of an Empire broadcasting station at Daventry. This station will comprise two transmitters, each capable of working on a number of wavelengths. It is expected that the station will be available for service in about a year's time.

During the year, work has proceeded at Regional centres for the modernising of studios and control-room arrangements. At the Scottish Regional headquarters in Edinburgh new control-room equipment is being supplied, while in the West Region a Talks Studio and offices were opened in Bristol. Negotiations are at present proceeding for an extension of the Midland Regional headquarters at Birmingham. In the North Region new premises have been obtained in Leeds.

PROGRAMMES

The Outside Broadcast department carried through a large number of important events. Running commentaries were broadcast on leading sporting events, including the Flyweight Championship of Great Britain, the Boat Race, the Grand National, the Derby, Tourist Trophy Races on the Isle of Man, and the Ards Circuit near Belfast, the principal tennis matches during the Wimbledon fortnight, the King's Cup Air Race, the St. Leger

and the Schneider Trophy. Commentaries on international Rugby football matches and on Association matches were broadcast.

MUSIC

The two-weekly Chamber Concerts have covered the classical and romantic schools and many interesting new works have been given. The regular engagements which it has been possible to offer the leading British Quartets have been instrumental in raising the general standard of performance of chamber music. These Quartets have included the Brosa, Virtuoso, Stratton, International, Griller, Kutcher, Catterall, Spencer Dyke and, on their return from America, the London String Quartet.

The intention of the Contemporary Concerts series, which has been an established programme feature since 1925, is to give authentic performances of outstanding works by the

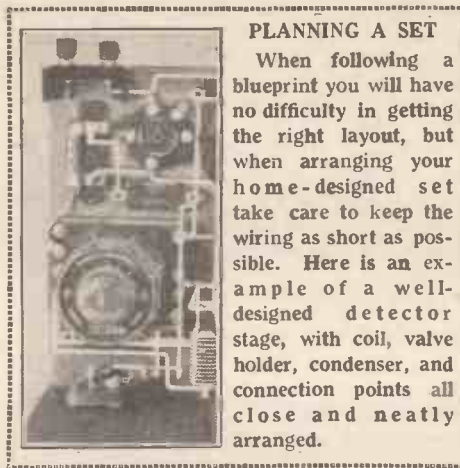

PLANNING A SET

When following a blueprint you will have no difficulty in getting the right layout, but when arranging your home-designed set take care to keep the wiring as short as possible. Here is an example of a well-designed detector stage, with coil, valve holder, condenser, and connection points all close and neatly arranged.

greatest masters of the representative British and European schools of orchestral and chamber music. Eight concerts were given during the early part of last year, in addition to which the B.B.C. Orchestra, National Chorus and Wireless Singers played an important part in the concerts of the annual Festival of the International Society of Contemporary Music which took place in July at Oxford and London. The 1931-1932 Contemporary Concerts, which have already begun, have included a Schonberg Concert, conducted by Dr. Boulton, and an English programme, conducted by Constant Lambert.

VAUDEVILLE

Vaudeville has continued to appear in the programmes three times a week, and has been distinguished this year by some very successful series; for example, the "Mrs. Feather" series presented by Jeanne de Casalis, the weekly Theatrical Cartoon, Gillie Potter's "Hogsnorton" series, Tom Clare's "Impersonations at the Piano," "Famous Faux Pas," by Isobel Elsom and Harold French, and so on.

Several new artistes have been brought to the microphone, including Haver and Lee and Max Miller. Old favourites and distinguished artistes have been José Collins, Cicely Courtneidge, Jeanette Macdonald, the film star; Stanley Holloway, Tommy Handley, Bransby Williams, Stainless Stephen, Harry Tate, Those Four Chaps, Wee Georgie Wood, Nellie Wallace, Ann Penn, Ronald Frankau, Bert Coote, Clarice Mayne, Horace Kenney, and many others.

RECORDING

A remarkable feature of the year's work in connection with the presentation of the broadcasts to the schools has been the extensive use of the Blattnerphone. A special technique is required for broadcast lessons to schools and by means of the Blattnerphone speakers are able to hear and correct their own defects. Furthermore, a speaker is able to visit a school while his talk is actually being broadcast and watch the listening class.

According to a French report, the 200-kilowatt Luxemburg (Grand Duchy) broadcast transmitter will begin its tests towards the middle of April next as its constructors have bound themselves to hand over the station ready for operation on July 20. Although the plant is of French origin the buildings in which it will be housed are to be erected by a German firm. These will be ready by January 15.

There are now some 470 wireless licences held in the lonely Shetland Islands. This new development has done much to link up the natives with the outside world.

A new radio typewriter known as a Watsongraph by which an operator can transcribe a message sent through the ether to another typewriter at a distance was recently tested out at Detroit (Mich). The receiving typewriter reproduces the message exactly as transmitted.

"HOW TO MAKE YOUR OWN SHORT-WAVE CHOKES"

(Continued from preceding page)

terminals on the ebonite tube should be tightened up well, after slipping the choke into position, so that they make good contact with the brass clips. The choke can be removed instantly, when it is desired to substitute another, by just unscrewing the terminal heads a turn or so and lifting the choke out of the clips.

If it is not desired to make the chokes interchangeable at all, exactly the same arrangement is used for the chokes themselves, but the holder is dispensed with altogether. The leads from other components in the set, instead of being connect-

ed to the terminals on the holder, are

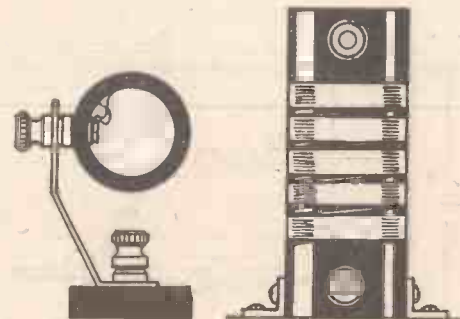

Figs. 4 and 5. Alternative methods of mounting the chokes

connected direct to the terminals on the

ebonite tube. The tube may be mounted directly on the baseboard of the set, as shown in Fig. 5, by means of two small right-angled metal brackets serving as fixing-lugs.

Short-wave chokes made on the lines described above are suitable not only for use in the anode circuit of the detector valve, but also between the anode of the output valve and one of the output terminals of the set, to prevent H.F. currents finding their way into the headphone or loud-speaker leads. When used in the latter position, it is advisable to connect a fixed condenser (of fairly small capacity) between the anode end of the choke and L.T. negative or earth, to by-pass the H.F. currents that are blocked by the choke.

W. OLIVER.

WE INTRODUCE ANOTHER REMARKABLE SET

THE
"1932
ETHER-
SEARCHER"

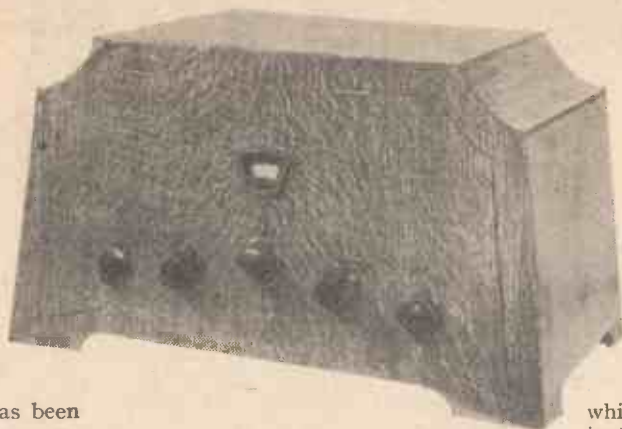

THE
VERY LATEST
IN
"THREE'S"

DURING the past year there has been a striking general increase in the power of European stations, and a rapid growth in the number of stations themselves. In many cases reception technique has not proceeded at the same pace, and sets which were efficient in 1930 and still useful in 1931 are now rapidly getting out of date. To cope with 1932 conditions, new-style receivers will be needed to give good tone and no heterodyning. The "A.W." Technical Staff has tackled this problem with the economy aspect always in view, and their latest production, an amazing new set, the "1932 Ether Searcher," is proof of what can be done to give quality, selectivity and simplicity at low cost.

The new "Searcher" embodies a straight circuit. It is not a super-het. It needs an aerial—not a frame—and its sensitivity is so great that quite a short length of indoor wire is ample for general reception. There are many cogent reasons why the Technical Staff has embodied a "straight" circuit in the new product.

BAND-PASS OR SUPER-HET

It is admitted by the leading technical experts that the two practical ways of achieving satisfactory selectivity with simple sets for amateur use are super-hetting and band-passing.

Ordinary filters and wave-trap circuits, helpful in improving old receivers, do not produce a sufficiently sharp tuning point, without distortion, to merit their inclusion in an ultra-modern layout. All band-pass arrangements are not, of necessity, efficient. Some give rise to annoying double-humping; others produce side-band cut-off, which spoils quality; and very many of both varieties are difficult to gang, where the three circuits of the band-pass aerial filter and the H.F. coupler are concerned. The method of band-passing embodied in the new set overcomes all these snags. The screening of the H.F. components is extremely effective, and when you see the photographs of the arrangement and start to mount the parts up for yourself, you will be surprised at the ingenuity displayed in the layout.

It is not intended to make wild claims for the new product of the Technical Staff. Nor is there need for exaggeration. Carefully made, the new set will satisfy the needs of the most discriminating listener, and the technical features of the layout,

THE EDITOR TALKS TO HIS READERS

THIS is my five hundredth number of "Amateur Wireless." Five hundred numbers! "Amateur Wireless" has become a "household word" throughout the country. We have helped to make wireless history. We made history last year with more than one set. Our

FIRST WINNER OF THE YEAR

was the "Ether Searcher," a set on new lines, clean in appearance, simple to build, remarkably successful in operation. It held the field entirely and even when we produced the "Super 60" in "Wireless Magazine" and the "Century Super" in "Amateur Wireless," there were still many thousands of readers who preferred the "Ether Searcher," with its remarkable simplicity and fine quality.

THE "1932 ETHER SEARCHER"

is a new version of last year's set, which retains all the advantages and adds a few of its own.

To the reader who might reasonably ask why we are not producing a set of different design and name, we will just say this: our readers have obliged us to give them another "Ether Searcher." It was undoubtedly the most popular band-pass set of last year.

We shall devote much space in our next issue to the new "Ether Searcher." We shall embody in the issue itself

FULL-SIZE WORKING DRAWINGS AND WIRING DIAGRAMS

of the set, which in every sense, except that they are printed with black lines on white paper, are exactly the same as a blueprint.

We are "telling the world" next week that "Amateur Wireless" will contain description and illustrations of the "1932 Ether Searcher," and I want your individual help in making our special issue known to all your interested friends. I guarantee that this new set will please both you and them. Our print order for next week will be considerably increased, but that will not ensure a copy for you unless you take time by the forelock and place your order Now.

BERNARD E. JONES.

Next Week's "A.W." ENLARGED, but SAME PRICE, 3d.

which will be described in detail, fully justify the slogan of "The Set of the Moment." The new "Searcher" is, without a doubt, the most up-to-date amateur-built receiver. It is yet one more proof that home-constructors are not lagging behind commercial-set manufacturers.

1932 practice in concentrated form is the essence of this new receiver.

CONSTRUCTION IS STRIKINGLY SIMPLE

The set is metal-shielded and completely stable. Of course it has one-knob tuning. It incorporates a link band-pass circuit of the most up-to-date type, capacity coupled, and the over-all selectivity is ample to cope with other conditions for a long time ahead. Stations are brought in at the turn of only the main tuning knob.

Operation is further simplified by a combined on-off-radio-gramophone switch at the front. This switches the whole set on and off, and also brings a gramophone pick-up into circuit so that electrical reproduction of records can be obtained. A 1932 set would not be complete without gramophone reproduction. In this new set there is no complicated plug-and-jack switching. You have only to turn the knob.

Great power output is ensured by a pentode in the last stage, and a very valuable feature is the provision of a tone control. Rotation of a knob enables the user to change the natural tone of reproduction to suit any particular item—a valuable feature for music lovers.

This new set is not the product of a moment. The Technical Staff has been hard at work on the design for several months and the "Searcher" has been given a rigorous testing in London and in the North of England. It is suitable for all British reception, and its amazing selectivity and reaching-out properties will ensure that listeners in certain centres, at present very difficult for radio reception, will get good results. In many districts possession of the new "Searcher" will mean good, interference-free reception for the first time.

The set is a three-valver, so that not only is the cost of construction within the pocket of every reader, but the running costs are abnormally low.

Both on technical and practical grounds our new set will be a winner

THE HOW AND WHY OF TUNING—XVII

BAND-PASS COILS IN PRACTICE

Another of a comprehensive series of articles on tuning, specially written for newcomers to wireless

BETWEEN the simple coupled circuit shown by Fig. 1 and the modern band-pass tuning circuit there may not, to the average beginner, seem much similarity. As I propose, in this article, to confine myself to the simplest mixed band-pass coils on the market, it will be a good plan to work up to their circuits from Fig. 1.

You may take Fig. 1 as the simplest

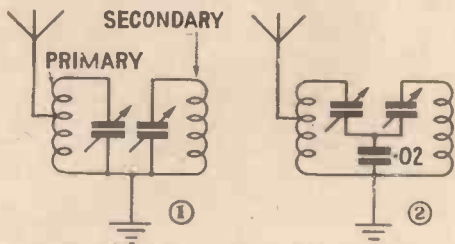

Fig. 1. Simple coupled circuit.

Fig. 2. How the Fig. 1 circuit is modified for band-pass tuning

possible band-pass tuning circuit, although properly it should be called a loose-coupled circuit. It consists of two separate tuning coils and condensers. There is no need for the common earth connection shown, since the coupling between the two coils is by the mutual inductance. But as one side of the secondary coil will be connected to the low-potential side of the following valve circuit it is desirable to anchor it to earth.

As mentioned last week, the simplest way of achieving band-pass tuning with constant peak separation over the whole of the tuning range is by means of mixed coupling. And the simplest mixed coupling consists of the mutual inductance of the two coils and a common capacity.

Fig. 2 shows how this common capacity is introduced. It consists of a non-inductive fixed condenser forming part of the tuning circuits. Comparing Fig. 1 and Fig. 2, the reader will readily see how this condenser is inserted. The two earth return leads of the two variable condensers are broken and joined together and to one side of the fixed coupling condenser. The other side of the coupling condenser then goes to earth, thus giving the Fig. 2 circuit.

Careful examination of the Fig. 2 circuit will show that the coupling condenser is virtually in series with each of the two tuning condensers. The value of the coupling condenser varies with different makes of coil. With the Lewcos coil it is .02 microfarad, and this is an average value. It is essential that the condenser be of the non-inductive type, as we do not want inductive coupling at this point. Any good make of paper dielectric condenser will do.

From Fig. 2 it is an easy step to Fig. 3, which shows the circuit of an actual band-pass coil, the Lewcos. The only compli-

cation, if we may call it such, is the provision of dual-range windings, so that band-passing may be obtained on medium and long waves. As usual, the long-wave windings are in series with the short-wave windings, and are short-circuited when receiving medium wavelengths.

The small condenser shown in series between the aerial lead and the tap on the medium-wave winding serves a very useful purpose in equalising the aerial tuning condenser for different aeriels. Being virtually in series with the aerial capacity this small condenser reduces the aerial capacity to a negligible amount.

Although the use of this condenser is recommended, it is also advisable to provide a trimming device on the tuning condenser, so that any discrepancy between the capacity of the aerial and grid tuning circuits can be made good.

Here I ought to mention that the most satisfactory method of tuning the Fig. 3 band-pass coil is by means of a two-gang condenser. This type of condenser has not, so far, been mentioned. It consists of two

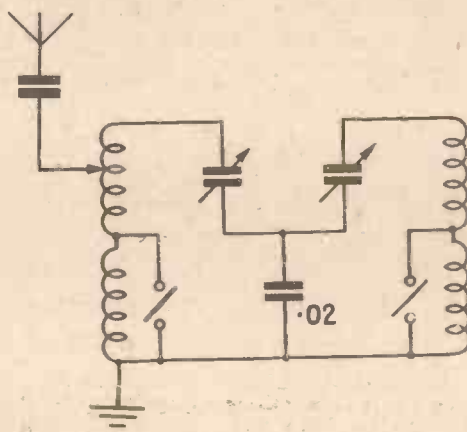

Fig. 3. Circuit of a simple commercial band-pass tuner with dual-range windings

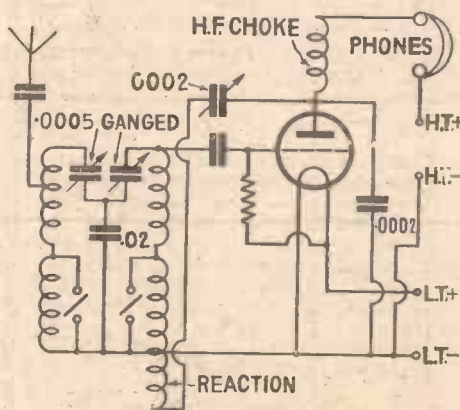

Fig. 4. Suggested one-valver using a Lewcos band-pass coil with reaction on the grid winding

exactly similar condenser sections, of .0005-microfarad capacity each.

Although the moving plates of each section are joined on a common spindle, the individual sections of the fixed plates are insulated from one another. A glance at the Fig. 3 circuit will show that this is essential, for the high potential sides of the two band-pass coils are entirely separate.

In most of the modern gang condensers

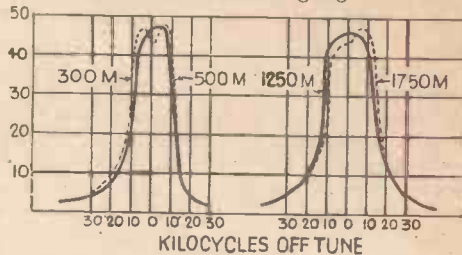

Fig. 5. These curves show how the Lewcos band-pass coil maintains a constant peak separation over all the available wavelengths

the end plates are slotted so that, before the condenser leaves the factory, the makers can adjust each section to give exactly the same capacity. The trimmers consist of small additional moving plates, usually mounted on the side of the fixed plates, so that the auxiliary capacity is in parallel with the main capacity.

There is no technical objection to the use of separate .0005-microfarad tuning condensers, but from an operating point of view there is everything to be said in favour of the gang condenser, which tunes the two band-pass circuits with the simplicity of operation associated with the most elementary single-circuit tuner.

To show how the band-pass tuning coil is used in a practical circuit, I have included the Lewcos in the Fig. 4 one-valver. Here we have a very selective headphone set, capable of getting the two local regional programmes quite clear of each other and, what is perhaps equally important, clear of interference from adjacent foreign stations.

The aerial is connected to the input coil through the small fixed condenser contained in the coil itself and two-gang variable tuning condenser is connected up with a .02-microfarad fixed condenser as shown. Note that on this coil there is a reaction winding, being a continuation of the grid section of the band-pass coil.

To link up with the curves given in previous articles, I am reproducing the resonance curve of the Lewcos band-pass coil, showing how the peak separation remains constant on both long and medium wavelengths. These curves show that all frequencies up to about 4,500 cycles on each side of the carrier frequency are tuned in, with a sharp cut-off on each side of this frequency limit.

HOTSPOT.



OUR BROADCAST CRITIC

TALKS ABOUT— VAUDEVILLE

ON the whole, the Christmas programmes were very much better than last year; on the other hand, there were weaknesses which should not have occurred in a holiday period.

Surely listeners never use their wireless more than at Christmas time? If that is so—and I am perfectly certain it is—no expense should have been spared on the programmes. What actually happened was that there were bright spots—simply because bright people were asked to broadcast; there were also dull spots because bright people were *not* asked to broadcast. At least, that is how it appealed to me.

One of the thrills of the holiday season was, in my judgment, the magnificent reciting of Henry Ainley in the National programme on Christmas eve. His English and his fine voice gave me, personally, a great aesthetic pleasure.

In the second group I thought the orchestral accompaniment not too effective. I was disappointed in the Hassan serenade on that account; I have always admired the music of Delius.

That by Norman O'Neill for *The Farmer and the Fairies* did not seem to me to matter either way; I think I should have preferred it to have been omitted.

I studied the programme of *Aladdin*, which was, apparently, "written, produced, conducted, orchestrated, and with the exception of certain interpolated numbers, composed by Ernest Longstaffe."

For some minutes I confess I could make nothing of it at all; everybody seemed to me to be shouting everybody else down. The lines were so poor (when, at last, I did hear a few) that I felt the whole production was not worth listening to.

Seeing Leonard Henry's name down, I thought there would be *one* bright spot in it; instead I found him very wishy-washy as Wishee Washee, but not through his own fault. He was obviously tied down. Had he been left to his own devices he would, of course, have been funny.

The Christmas songs, as sung by John Coates, were a pleasant contrast; he chose charming songs and rendered them with his customary personal charm. To my way of thinking, his was easily the best broadcast on Christmas evening.

Of course, I had read in the papers all about the people who hurriedly wrote something to take the place of *Half the*

World Away, which was not to be given.

I was quite disposed to be lenient towards it, but I found myself getting very bored until Stanley Holloway livened up things a little; his imitation of Ainley was exceedingly clever.

Nothing else of interest happened until Alexander and Mose came on and saved the situation. All of which proves that it is unfortunately a fact that the only entertainments worth while on the wireless are those by the established few.

A vaudeville on Boxing night was presented in which only favourites appeared and very good they were, too.

Ernest Butcher sang good songs and sang them well; Cicely Courtneidge was extremely funny, especially in the French restaurant scene. I never heard Flotsam and Jetsam to better advantage, Jetsam being in excellent voice; Elsie and Doris Waters gave one of their best broadcasts, the reminiscent chat being as amusing as ever; Clapham and Dwyer improved upon their own excellence; Tommy Handley was both seasonable and laughable; finally, Mabel Constanduros and Michael Hogan, as the various members of the now notable

Buggins family, added greatly to the general enjoyment, "Grannie" being in thoroughly good form.

I think the vaudeville producer is to be congratulated upon playing for safety first and engaging so many good artistes. Naturally, such a programme would not be cheap to produce; I can only trust we shall not have to suffer for it by being given poor quality for a week or two to make up.

Gillie Potter, in a solitary broadcast on Boxing morning, was as funny as ever in his vivid description of how he spent Christmas at Hogs Norton. I hope he will go down there next Christmas.

Earlier in the week I listened to Alexander and Mose with pleasure. I should like to say a word to Alexander, if I can do so without causing offence. Your voice, sir, is a little heavy for Mose's—or, perhaps it would sound better if I said *for that of Mose*. I toned up my speaker for him and found that you "blasted" a little; then I toned you down and *lost him*. I am sure you will like to know of this; if you yourself will speak a little softer it will be easier for listeners to get both of you perfectly.

PREPARING VAUDEVILLE IN THE STUDIO



Those two popular broadcasters, Jack and Claude Hulbert, rehearsing a new act before the microphone in one of the Savoy Hill studios

Bransby Williams, as "Scrooge," was better than ever, I thought. May I suggest that we have more of him during the year, and *always* on Christmas Eve in that part.

Jeanne de Casalis, in her various Mrs. Feather episodes, must now be very popular indeed. I thought her entertaining on the Monday evening.

Isolde Menges still have delighted many listeners on the Sunday; her recital contained violin works that ought to have been easily understood by the most casual and indifferent listener. I thought her tone very beautiful, especially in the charming Lullaby, by Verne.

WHITAKER-WILSON

"WHY must wireless sets be cumbersome?" ask potential listeners who have not space for console radio-gramophones or large cabinet sets. Wireless parts are not large. Why must sets generally be bulky?

Here is a novel three-valver designed to prove that, still keeping a high standard of efficiency, dimensions can be cut down to a striking limit.

The overall dimensions of this little set are 6 in. by 4½ in. by 4½ in.!

It is probably the smallest complete valve set ever produced for amateur home construction, and it is certainly one of the most efficient. Although a midget in size, it is not a midget in performance. The third valve of the three-valve combination is a power valve, and if a suitable type is chosen from the table which will be given next week, sufficient power output can be obtained to fill a large room.

An Efficient Circuit

The circuit is of the type popularly known as "detector, R.C., trans." and although the tuning of the set is efficient, making it quite easy to get at least half a dozen foreign stations at full speaker strength, the chief purpose of the little set is good tone and ample power on the local broadcasters.

Technical wisecracs may wonder how it has been possible to squeeze a quart into a pint pot and still keep good performance. The photographs clearly show how a neat layout has been arrived at and how both above and below the baseboard the wiring is commendably neat. The baseboard is actually in box form and is made of 5- or 7-ply wood. The dimensions are clearly given on the wiring plan. This carries on top the three valve holders and the low-frequency transformer.



The little plywood panel, 4½ in. by 6 in., at right angles to the box baseboard, supports the tuning and reaction condenser, the on-off switch and the pre-set aerial condenser.

Few Components

The home-made tuning coil is supported partly by the panel (where it is clamped by the one-hole fixing nut of the wave-change switch) and at the back by a small L bracket.

As there are so few parts above the baseboard, there is very little wiring to be seen. The smaller parts and the detailed wiring are carried underneath in the inside of the box.

Connections

Most of the wires are very short, and in many cases it has been possible to dispense with wires because the connecting points of various parts have been connected directly together. The three valve holders are of the under-baseboard mounting type, so that this cuts down still fur-

ther the amount of wiring above the baseboard.

The flex leads twisted in three groups, for high-tension, low-tension, and grid-bias, pass out through a hole at the back of the baseboard box. On this same strip are carried four midget type terminals. Those on the right, looking at the set from the back, are for aerial and earth; those on the left are for connection to the speaker.

What could be simpler?

Simple Controls

The controls on the front of the panel are simple, too. The tuning condenser on the left (this is virtually the only tuning control) and the reaction condenser, which on local stations can be used for volume control, is on the right.

Between these knobs is the wave-change switch, pushed in for long waves and pulled out for medium waves, and below, in the centre, is the on-off switch.

Just how these take effect in the actual circuit can be seen on reference to the

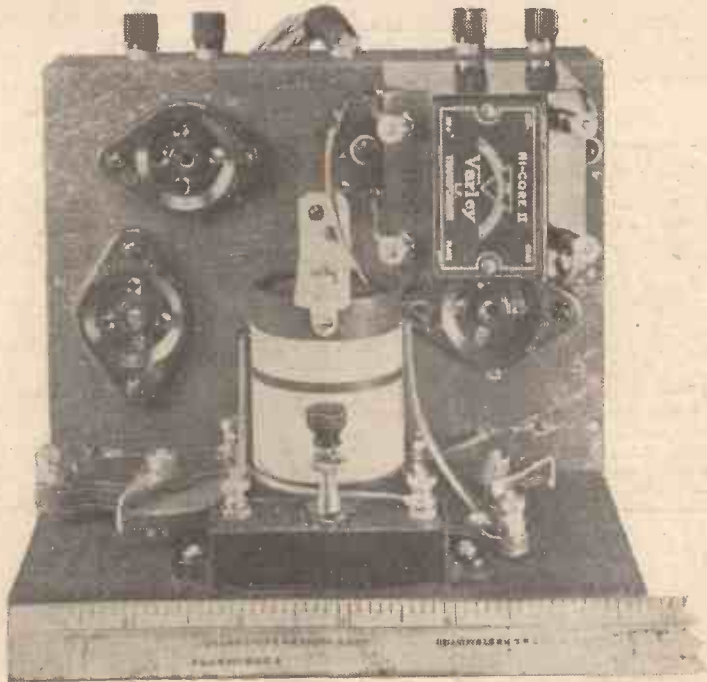

The diminutive size of the "Baby '3'" is apparent from his photograph

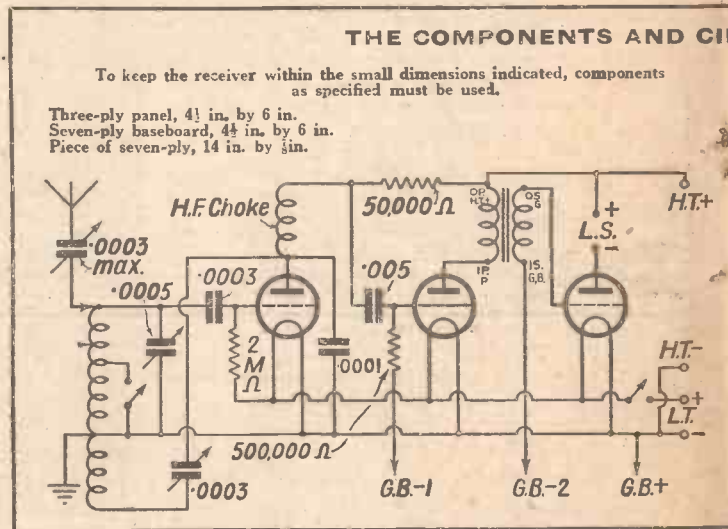

BABY 3

The constructional details of a strikingly novel "midget" three-valve set designed by JOHN B. CROFTS

theoretical circuit diagram. The coil, the construction of which will be described later, is tuned by a .0005-variable condenser in parallel and the aerial is placed in series with a pre-set condenser having a maximum of .0003 microfarad.

Leaky-grid Detector

The detector, operating on the leaky-grid principle and with the normal values of .0003-microfarad and 2-megohms for the condenser and leak respectively is resistance coupled to the first L.F. valve. The use of a spaghetti resistance for this coupling ensures that very little space is taken up under the baseboard. The middle valve is transformer coupled to the power valve, a Ni-core II transformer being used.

There are no output arrangements from the power valve to the speaker, but, of course, an output choke or transformer can be used outside the set in cases where the mains are being used for H.T. and one must keep the high-tension current out of the speaker windings.

Home-made Coil

The home-made coil cuts down the cost of the set by a noticeable amount, and it is very easily made. It consists of a short length of former inside which is a piece of ribbed ebonite former, carrying the long-wave winding. The medium-wave turns

and the reaction winding are on the outer former. The general construction is made clear by an accompanying diagram which shows the coil in section. For the outer former you will need a 2½-in. length of 1½-in. outside diameter ebonite or paxolin tube. On this wind ninety turns of 36 d.s.c. and then, leaving a ¼-in. gap, wind on in the same direction a further separate winding of forty turns of the same wire. This is for the reaction coil.

The long-wave winding is on a 7/8-in. length of 1-in. diameter ebonite former. Ribbed former such as the Becol No. 5 choke type should be used. Two sections are cut to carry the wire, each section having two hundred turns wound in the same direction. The

long-wave former is bolted to the bracket which supports one end of the outer former and it should be mounted so that the turns are in the same direction. The leads are brought out from the coil to the single-contact type of wave-change switch which short-circuits the long-wave winding when the set is working on the medium waveband.

When winding the coil leave the ends long enough conveniently to reach the switch. Otherwise it will not be easy to wire up the wave-change switch. It will be seen that the aerial lead can be taken to a tapping 60 turns down the coil.

The total cost of the components for the "Baby 3," using the parts specified in the accompanying components list is approximately £1 18s.

In a set of this kind a full-size blueprint is invaluable. Copies of this can be

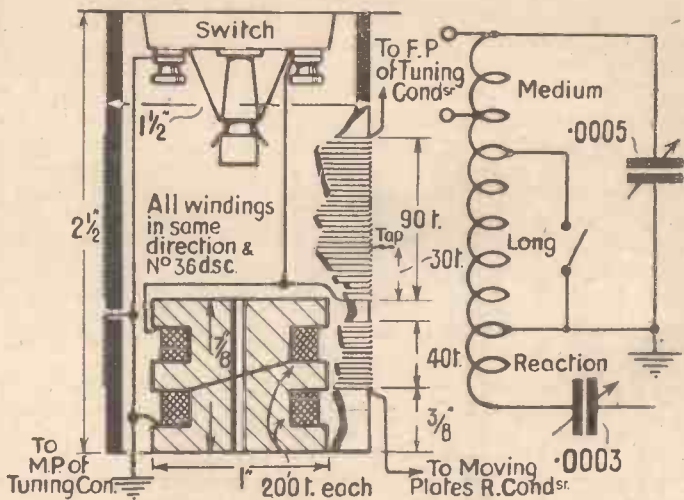

The coil is home-made and the constructional details are given by this diagram



Although the set is so small, the performance equals that of the average three-valver

COMPONENTS LIST OF THE "BABY 3"

- .0005-mfd. variable condenser (Polar "Compax.")
- .0003-mfd. variable condenser (Polar "Compax.")
- Three sub-baseboard valve holders (W.B., "skeleton" type).
- Two push-pull on-off switches (Bulgin "Junior").
- One .005-mfd. and one .0003-mfd. fixed condensers (Dubilier, type 670, Formo, T.C.C.).
- .0001-mfd. fixed condenser (Dubilier, type 655, Formo, T.C.C.).
- 2-megohm grid leak, with terminal ends (Lissen).
- High-frequency choke (Lewcos).
- 500,000-ohm resistance, with wire ends (Dubilier "Miniwatt").
- 50,000-ohm spaghetti resistance (Lewcos, Telsen, Sovereign, Read-Rad, Varley).
- Low-frequency transformer (Varley "Nicore II").
- Pre-set series aerial condenser, .0003-mfd. maximum (Sovereign, type J, Formo, Telsen).
- Four miniature terminals (Belling-Lee).
- Two spade terminals, marked L.T.+, L.T.- (Belling-Lee).
- Five wander plugs, marked G.B.+, G.B.-1, G.B.-2, H.T.-, H.T.+ (Belling-Lee).
- Three yards of thin flex (Lewcoflex).
- Connecting wire and sleeving (Lewcos).
- Piece of ebonite tube, 2½ in. long and 1½ in. diameter (Becol).
- Piece of ribbed former, 1 in. diameter, with 4BA hole down centre (Becol, type No. 5 Choke).
- 1 oz. 36 d.s.c. wire (Lewcos).

ACCESSORIES

- 120-volt H.T. battery (Ever Ready, Drydex, Lissen, Pertrix, Fuller).
- 9-volt G.B. battery (Ever Ready, Drydex, Lissen, Pertrix, Fuller).
- 2-volt accumulator (C.A.V., Exide, Pertrix).

“THE ‘BABY’ 3” (Continued from preceding page)

Obtained, price 1s., post free, from the Blueprint Department, AMATEUR WIRELESS, 58-61 Fetter Lane, London, E.C.4. A small reproduction of this is given herewith.

It is helpful because it shows exactly where the various parts are mounted and gives details of the point-to-point connections. Also, in this instance, the print is handy because it gives the dimensions for the woodwork. The top of the baseboard must first be cut to size and the three holes cut out for the valve holders. Then the three sides of the box may be cut, the 6-in. long side having the five holes drilled in it for the battery leads and for the four terminals. Now cut and drill the thin plywood panel.

Wiring

Tinned copper wire should be used for wiring and should be covered with insulated sleeving. Alternatively, wire of the Glazite variety may be used.

The battery flexes, of course, make

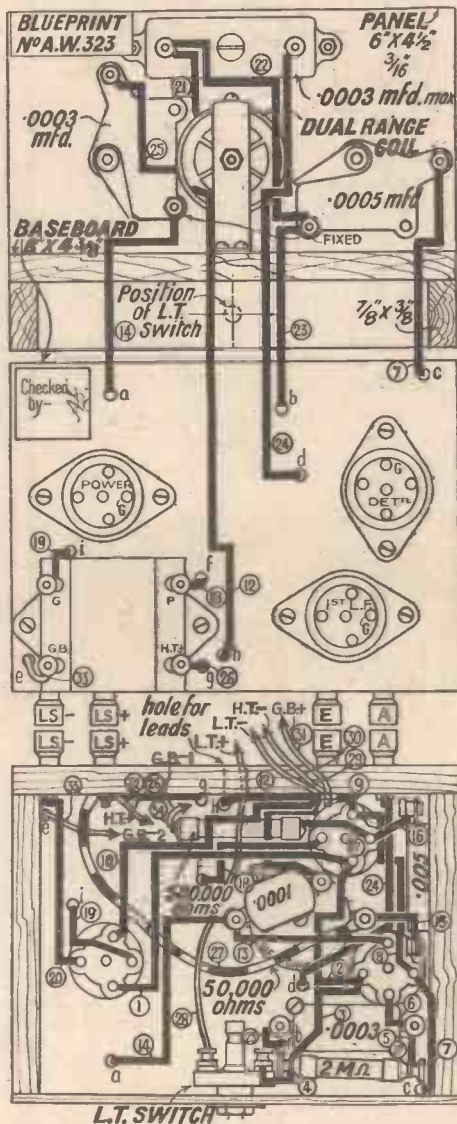

The layout and wiring diagram. A full-size blueprint is available, price 1/-

connection direct with the various points. One or two leads are so short that it is neither possible nor necessary to put on any insulated sleeving.

Follow the blueprint carefully and, having mounted the two condensers on the panel and the coil, put on as many wires as possible. Small coupling condensers and the two grid-leads may be wired up beneath the baseboard as one comes to them. One terminal of the H.F. choke (this component is screwed to the baseboard) acts as the anchorage point for a coupling condenser and spaghetti resistance. Details such as this make for compactness in the complete receiver.

One battery lead, for grid-bias negative, comes up through a little hole in the baseboard to the G.B. negative terminal on the transformer. Another wire comes up through the baseboard to the pre-set condenser.

Checking

If you follow the blueprint carefully, especially where it shows the under-baseboard details, you cannot go wrong.

The leads are numbered on the print and if you wire up in the order indicated there will be no possibility of leaving out a lead.

In next week's issue, final details and operating instructions will be given for the "Baby 3." In the meantime, London readers who would like to see the actual set should see the special display in the Radio Department of Messrs. Selfridge & Co., Ltd., of Oxford Street, London, W.

THE NEW TRIESTE

TRIESTE, the new Italian high-power station, has been started at Monte Radio, in the suburbs of Trieste. The new station was officially opened in the presence of the Crown Prince and Crown Princess of Italy. The completion of Trieste is a further step in the reorganisation of the Italian broadcasting system undertaken by the E.I.A.R.—the Italian Broadcasting Company—which aims at covering Italy with an adequate broadcasting service.

The Trieste transmitter was manufactured at the Marconi works at Chelmsford. Powerful water-cooled valves are used in the main amplifying stages. The unmodulated power is 10 kilowatts; modulation up to 100 per cent. can take place so that the C.C.I.R. rating amounts to 15 kilowatts. The transmitter covers the waveband of

200 to 545 metres, but the working wave of the Trieste station is 247.7 metres.

A special crystal drive, fitted in a heat-insulated box with thermostatic control, prevents any variation in the wavelength.

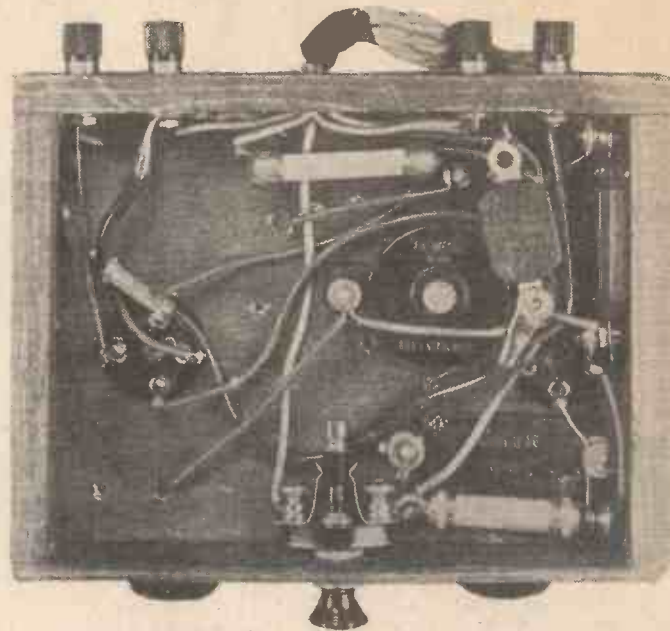

This plan view of the "Baby 3" shows how the under-baseboard parts are wired

Two masts, each 250 ft. high, carry the aerial. The down lead descends vertically to a feeder house below the aerial, half way between the masts. Feeder lines on poles convey the aerial power from the transmitter output stage to the feeder house.

All programmes come from Trieste's own studio. M.

ON THE SMALL SIDE

ONE hundred million atoms placed side by side measure approximately one inch from end to end. Having set the scale, so to speak, one can begin to get some idea of the relative size of an electron knowing that 60,000 of them will fit along the diameter of a single atom. In spite of this, the atom has less than two thousand times the mass of the electron, so that its density is comparatively high. M. A. L.

THE FIRST ELECTROMAGNET

ALTHOUGH Faraday was undoubtedly the first to explore systematically the relation between magnetism and electricity and to lay down the laws of electromagnetic induction, the first practical electromagnet was constructed a few years previously by a poor shoemaker named William Sturgeon. It consisted of a bar of iron, bent into the shape of a horseshoe and wound with iron wire carrying current from a voltaic cell. It could support a weight of nine pounds. Sturgeon presented his electromagnet to the Royal Society of Arts in 1825, and was awarded a silver medal and a special prize of thirty guineas. B. A. R.

IF YOU ARE CONTEMPLATING BUILDING A SET—STUDY THE BLUEPRINT LIST ON PAGE iii OF THE COVER. THERE IS A SET FOR EVERY NEED

Full size 1/- plan... Free

Go to your radio dealer. Ask him for your free copy of the Meteor Folder which describes fully the most interesting receiver ever designed and includes full-size plan and wiring diagram with complete building instructions. The easiest set to build. No drilling or cutting, no soldering—a screwdriver and pliers are the only tools you need. Quality components throughout.

If any difficulty in obtaining your Free Meteor Folder, post coupon now to Ready Radio, Ltd., Eastnor House, Blackheath, S.E.3.

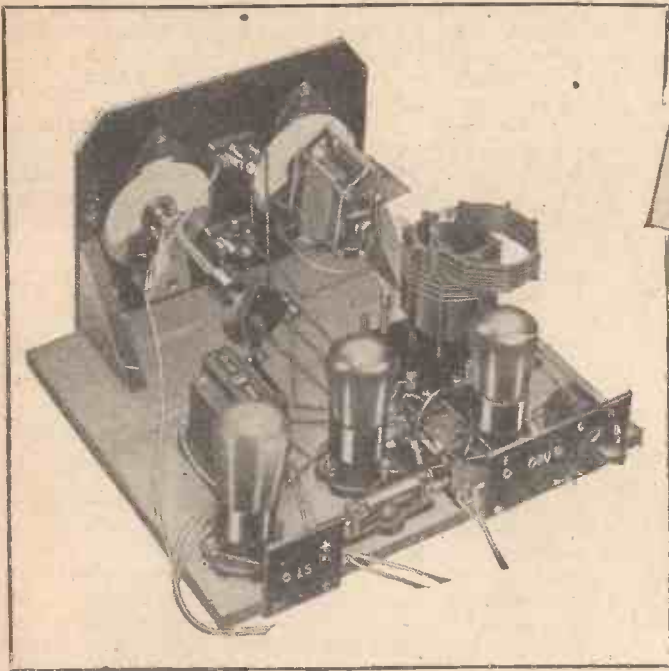

70 Extra Stations

Do you realise that there are over 70 Short-wave Stations in all parts of the world transmitting programmes which cannot be heard on the ordinary type of receiver? Think what you are missing by not hearing them. Imagine the thrill of tuning in America, Africa, Australia, and other far-distant countries on your own set. The Meteor combines all the attractions of quality performance, simplicity of operation, sensitivity, selectivity, and handsome appearance with the fascination of world-wide reception on ALL WAVELENGTHS. With a pick-up connected to the sockets provided, your Meteor becomes an electrical reproducer of gramophone records at a flick of the Radio-gram switch.

METEOR III KIT

Complete set of quality components, including panel (cut and drilled), baseboard, Jiffilix, flex, screws, plugs, etc. 75/- or 9/- down and 7 monthly payments of 10/6

STANDARD CABINET KIT
(Complete Kit with Standard Cabinet to house set only) **89/6**
or 11/- down and 8 monthly payments of 11/-

CONSOLETTA CABINET KIT (Complete Kit with Consolette Cabinet to house set, speaker and batteries) **£5.0.0**
or 11/- down and 9 monthly payments of 11/-

Choice of Recommended Accessories

Mullard Valves			
1—P.M.2 DX	8	6	
1—P.M.1 L.F.	8	6	
1—P.M.2	10	6	
Batteries			
Pertrix 120-v. super capacity	1	5	6
or			
Pertrix 120-v. Standard	15	6	
or			
Ever Ready 120-v. Popular Power	1	4	0
Pertrix 9-v. G.B.	1	6	
or			
Ever Ready 9-v. G.B. Accumulators	1	0	
Fuller 2-v. 20-amp. type S.W.X.H.5.	8	3	
or			
Pertrix 2-v. 20-amp. type P.X.C.2	9	0	
Loudspeaker Chassis			
R. & A. type 40 re-producer	16	6	
or			
Celestion chassis type M.12	1	15	0
or			
Blue Spot Special chassis and 60 P. unit	1	15	0
Gramophone Pick-up			
B.T.H. Minor	1	7	6
or			
B.T.H. Senior	2	5	0
Volume Control			
Readi Rad 5-meg.	5	9	
Gramophone Motor			
Collaro Type B.30 with unit plate and automatic stop	1	13	0

READY RADIO METEOR III

G. P. Kendall, B.Sc., the designer of the METEOR III, has written a book entitled: "Ten Hows for Modern Radio Constructors." It settles every radio problem for you. Send four 1d. stamps for your copy now.

ALL BRITISH

Name.....
Address.....
A.W. 9/1/32 BLOCK LETTERS—IN INK—PLEASE

Special features of the Meteor: 18 to 1 slow-motion drive on both tuning and reaction; extended anti-capacity reaction control; adjustable selectivity; Kendall loose-coupled air-spaced coils; radio-gram switching, etc., etc. Designed by G. P. Kendall, B.Sc.

Daily demonstrations of this wonder receiver at the Ready Radio Showrooms: 159 Borough High Street, London Bridge, S.E.1. (2 minutes from London Bridge Station.)

Mention of "Amateur Wireless" to Advertisers will Ensure Prompt Attention



Constructional details of this remarkable Super-het, designed by W. JAMES, were given in the two preceding issues

THE amount of the amplification provided by this set is controlled by adjusting the grid bias of the two valves used in the intermediate amplifying stages.

Valves

Variable-mu valves are used, as the amount of distortion introduced as the grid bias is altered over a wide range is usually negligible. Ordinary screen-grid valves cannot be used in the two intermediate frequency stages. The amount of the amplification obtained from them may certainly be varied by adjusting the bias, but rectification and distortion is almost bound to occur.

Do not try ordinary screen-grid valves, therefore, as the results will be poor. There would be ample magnification, but very poor control of the strength, with the result that the stronger signals would be badly received. It is always necessary to ensure the clear reception of the local stations and of others that are picked up at good strength. For this reason the volume control must be capable of varying the magnification over a wide range. The grid-bias control of the multi-mu valves is satisfactory in this respect.

The valves used in testing the set and found quite suitable were:—

- 1 Cosmor 41 M D.G.
 - 2 Mullard MM₄V
 - 1 Mullard 354V
 - 1 Mullard PM₂₄A
- Rectifier: Mullard DW₂

Although the aerial circuit includes a band-pass tuner, the actual tuning of the oscillator will be found more sharp. Owing to the band-pass characteristics of the amplifier, the tuning of the oscillator is not critical, but a station is held over a part of a degree. This is a convenience in tuning. The sharpness of the tuning of the aerial circuit two-gang condenser will depend to an extent upon the accuracy of the ganging of the two circuits.

If the two coils of the band filter are of equal inductances and the two parts of the tuning condenser have been adjusted to provide equal capacities in the two circuits, then they will tune accurately. If there is any doubt about the matter, a rough test is to take the aerial through a pre-set condenser or one of small capacity, such as .0005 microfarad, to the G terminal of the band-pass coil. This connects the aerial to

the grid circuit of the valve and only one coil and tuning condenser is included in the circuit.

The signals will normally be only a little stronger than when the band-pass unit is used and the selectivity will not be nearly as good. But if the band-pass circuit is badly out of tune, the volume and selectivity obtained when it is connected, will be poor and better results will be obtained with the aerial joined as explained.

If the fault in the band-pass circuit cannot be found, the coils and condenser should be returned for examination. It is not fair to the set to use only one coil of the input filter, and the connection should be tried only if in doubt as to the correctness of the filter circuit.

Using a Pick-up

A pick-up could be connected to the grid of the detector valve, for playing gramophone records. If the leads from the pick-up are taken to the grid and cathode of the detector, the results will not be very good.

In the first place, the valve will not be biased for amplifying and, secondly, the signals from the pick-up will cause grid current to flow. A separate volume control

must, therefore, be used and the output from it taken to the circuit. If a simple switch is inserted in the grid lead for the purpose of breaking the radio circuit and connecting the pick-up, the results will be better. But for really good results bias must be used.

A 600-ohm resistance, shunted by a 1-microfarad condenser, might be joined to the cathode lead for bias, but it is easiest to use a single dry cell. The positive side of the dry cell is joined to the cathode and the negative is taken to the volume control of the pick-up. This leaves a wire from the volume control, which must be taken to the grid, either direct or through a switch.

Excellent Quality

The quality of the reproduction to be obtained from the set is such that a good moving-coil loud-speaker is recommended. Some makes are lower toned than others, but this is easily corrected because the pentode used in the last stage normally tends to emphasise the treble. A filter, consisting of a resistance with or without a condenser, may be joined across the output from the set to reduce the strength of the higher frequencies. The amount of the reduction may be adjusted in order to make the quality just right. Usual values, as given before, are 20,000 ohms and .005 microfarad joined in series across the output.

It is necessary to fit the loud-speaker rather carefully if the set is to be finished as a self-contained type. Vibrations from the loud-speaker may reach the valves and cause howling, but this is to be avoided by fitting the loud-speaker upon a mounting of soft material. If necessary a piece of wood should be fitted between the sides of the cabinet in order to avoid vibration and the set may be fitted upon rubber or screwed in position according to the results obtained.

MAINS UNIT CONNECTIONS

Commercial eliminators are generally provided with safety plugs and sockets for connection with the mains, but in home-built units constructors are apt to take too little precaution. The mains lead should be con-

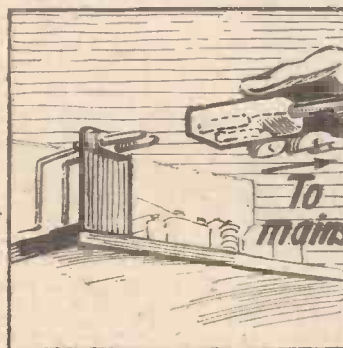

nected to a socket with sunken contacts and the pin end of the connector should be connected to the unit. In this way there will be no exposed metal parts having the full mains potential across them.

NEW LANDLINE FOR B.B.C.

AS readers may already know, the B.B.C. is making use of the new high-quality land lines between London and Leeds and Manchester, and between London and Daventry to Birmingham; the new cable linking Leeds with Newcastle and Edinburgh will shortly be handed over to the B.B.C., so when Falkirk opens it will have the advantage of first-class line connection with London.

AMATEUR WIRELESS
says:—
 "Modern band-pass coupling gives excellent selectivity without loss of quality."

For circuit diagrams showing how to build a "Square Peak" Set, write for colour leaflet and for circuit folder Z.

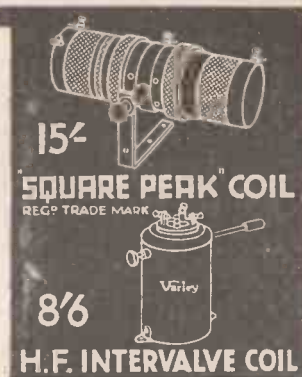

"SQUARE PEAK" COILS

[REGD TRADE MARK]

Recommended by "Amateur Wireless," "Modern Wireless," "Popular Wireless," "Wireless Constructor," "Wireless Magazine" and "Wireless World" and used in their Star Circuits and Exhibition Sets.
 "Gives amazing selectivity . . . is fine for distance-getting . . . no interference from local stations."—*Amateur Wireless.*

"The best commercial wave-change coil unit yet produced."—*Popular Wireless.*
 "With the Varley Coil there is substantially a square-peak resonant curve nine kilocycles in width."—*Wireless Constructor.*
 "Cuts off interfering stations in a surprising manner."—*Wireless Magazine.*

Why not give your receiver the wonderful improvements of "Square Peak" band-pass tuning?



Advertisement of Oliver Pell Control Ltd., Kingsway House, 103 Kingsway, London, W.C.2
 Telephone: Holborn 5303
 I.F. S. Representative: L. R. WOOD, 116b St. Stephen's Green, Dublin

To Ensure Speedy Delivery, Mention "A.W." to Advertisers

SETS OF DISTINCTION

EDDYSTONE SUPER-HET CONVERTER

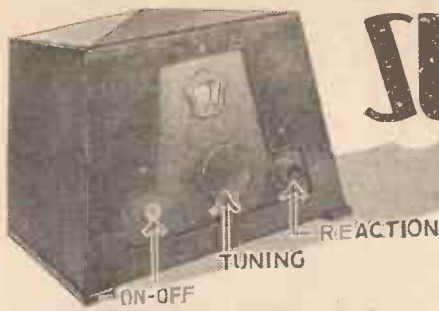

Makers: Stratton & Co., Ltd.

Price: £4 17s. 6d.

SUPER-HET converters are all the rage just now. This is quite understandable, for by the aid of a one-valve you can convert a normal three-valve set into a wonderfully sensitive four-valve short-wave super-het set. The marvel to me is that this type of unit, the circuit of which has been known to amateurs for several years, has not caught on before now.

Good Short-wave Practice

In the Eddystone short-wave converter we have an excellent example of an oscillator detector arranged for "super-hetting" a broadcast set. As might be expected from the firm of Stratton & Company, the design of the Eddystone converter follows the best short-wave practice.

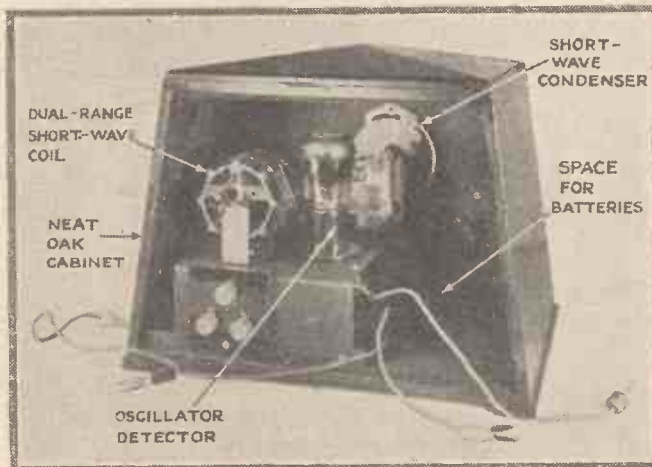

This picture shows the internal arrangements of the Eddystone super-het converter

It will be of interest to explain briefly how such a unit works. Firstly, we have the valve of the unit arranged with a grid leak and condenser to oscillate easily on the short-wave band. The grid circuit of the oscillator valve comprises a short-wave tuning coil and variable condenser, and in the anode circuit is the usual reaction system, with the amount of reaction controlled by a variable condenser in series with the reaction coil, which is closely coupled to the grid-tuning coil.

Slight Mistuning

Now suppose we allow the valve to oscillate, and set the tuning to some short wavelength. If there is a signal coming in on a slightly different wavelength it will beat with the locally-generated oscillation and the result will be a signal of a wave-

length corresponding to the difference in frequency between the incoming signal and the frequency of the local oscillation.

In other words, if we slightly mistune any short-wave signal with the valve in an oscillating condition we shall produce a supersonic frequency in the anode circuit of the valve. And if we arrange two chokes in series in the anode circuit, one a short-wave choke and the other a long-wave choke, placing the short-wave choke nearer the anode, we shall, at the junction of the two chokes, have a new modulated frequency which can be handed on to the first high-frequency amplifier of the broadcast set.

The new frequency, created by the beat effect between the incoming signal and the local oscillation, will correspond to a long wavelength. On an average short-wave signal not greatly mistuned by the oscillating detector the new frequency would correspond to about 2,000 metres.

Thus it is that we can convert all incoming short-wave signals to a long wavelength, and the new frequency signal can then be amplified by the broadcast set without any alteration to it.

All you have to do is to disconnect the aerial lead from the existing set, connect it to the aerial terminal of the adaptor, and join the anode of the adaptor valve through a fixed coupling condenser to the aerial terminal of the set.

Naturally, much of the success of this system depends upon the efficiency of the oscillating detector, and it is in this connection that the makers of the Stratton converter have done well. As the illustrations show, the unit is compact, even though it contains the high- and low-tension batteries for running the valve. By the way, for those with battery-operated sets there is no need to duplicate the power supply—the unit without batteries costs only £4 5s.

A neat little metal chassis fits into the oak cabinet, and upon it are assembled the short-wave coil and tuning condenser, with the reaction condenser and battery switch to the right and left of the large tuning knob. This knob works the tuning con-

denser on a remote control spindle to avoid hand-capacity troubles. It also actuates a clearly-engraved tuning scale, marked in degrees from 0 to 180.

Stout battery leads come from the chassis to make connection with the self-contained Pertrix 60-volt high-tension battery and the Exide 2-volt accumulator. The valve is a Mullard PM₂DX detector, very suitable indeed for this particular job.

Dual-range Coil

A novel point about the short-wave tuning coil is that it is dual range. When the knob at the back of the coil is pulled out the range of the unit is from 15 to 32 metres. When this knob is pushed in the range is from 30 to 65 metres. The coil windings comprise stout-gauged enamelled copper wire, wound on a low-loss ribbed former.

At the back of the chassis are three terminals, one each for the aerial and earth leads and the remaining one for the connection of the unit to the broadcast set.

I have been using the unit with a four-valve A.C.-mains set, and although I am well acquainted with the circuit principle of the adaptor I must confess to some surprise at the extraordinary results I have been getting on the "ultra shorts." The first station I tuned in was 2YAF, the 31-metre relay of WGY, of Schenectady, New York. The strength of this American's signals was sufficient to overload a super-power valve.

No less remarkable than the volume was the consistency of the signal. And there was absolutely no fading to inaudibility. At times the signal strength varied, but with so much power in hand there was never any question of losing the gist of the nasal announcements. By the way, this reception was effected between 6 and 7 p.m. G.M.T., corresponding to 1 and 2 p.m. Eastern Standard Time. I have not heard this station in the late evening, but he is very strong at the times mentioned.

For the best results I found it was necessary to tune the broadcast set to about 1,850 metres, but the actual wavelength of the set was not critical, and good results were obtained between the limits of 1,600 and 1,800 metres. Once this setting had been found there was nothing else to control on the set, tuning and reaction being done entirely on the Stratton unit.

While praising the unit very highly, I should perhaps make it clear to readers that only sets with at least one stage of high-frequency amplification can be converted.

SET TESTER.

YOU CAN'T BE DISAPPOINTED IF YOU BUILD IT WITH

Components are built to a purpose—not to a price, although they cost less than others, efficiency considered. To buy R.I. components is not experimental, it is the sensible choice of set builders who utilise the best that Radio Service can give to determine absolutely certain results.



G.P. CHOKE

Quite essential for efficient H.T. smoothing and for choke filter output coupling. The high permeability core gives the inductance which is necessary for choke components in modern receivers. The inductance is 25 henries. Encased in green bakelite.

12/6

QUAD ASTATIC Choke

A thoroughly good dependable choke for all suitable circuits. Absolutely the best for parallel feed amplification. Maintains high impedance without loss of H.F. voltage. Gives entire freedom from blind spots and acts efficiently over the whole of the broadcasting wavelengths. Its astatic winding prevents H.F. interference with adjacent components.

3/6

"DUX"

The Dux is the foremost British Transformer, built to give highest efficiency at lowest cost and to prevent the imposition of inferior foreign and other dubious transformers upon the British radio public.

6/9

30 HENRIES

is its inductance—a truly remarkable qualification giving a performance described in the test reports of reputable Wireless Journals as equal to transformers at many times the price. The published technical data is your guarantee of performance.

Ratio 1 : 3½ (standard) or 1 : 4½ (auto-connection).

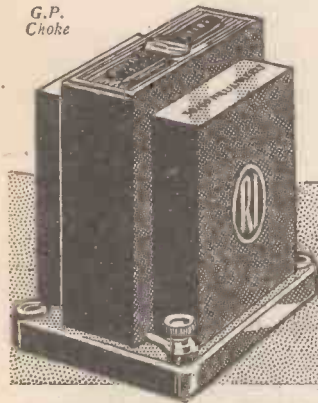

G.P. Choke

QUAD ASTATIC Choke

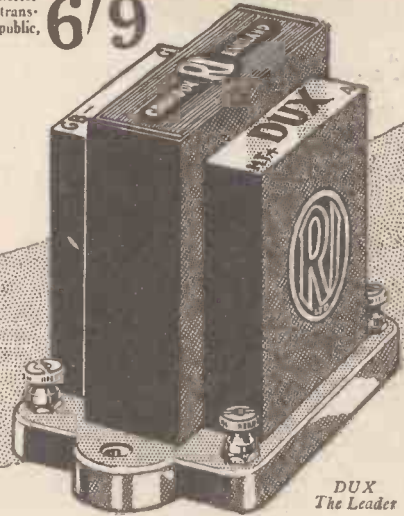
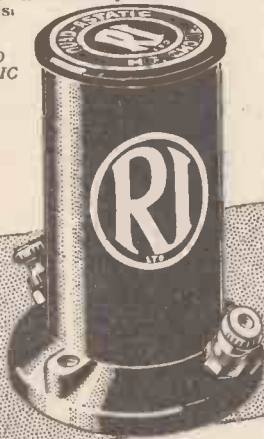

DUX The Leader

COMPLETE THE CIRCUIT OF SATISFACTION WITH



The Advertisement of Radio Instruments Ltd., Croydon, England. Phone: Thornton Heath 3211 (5 lines).

SOLID DI-ELECTRIC



RIGID CONSTRUCTION

BONDED ROTOR VANES

SILENT AND SMOOTH ACTION

POLAR

"COMPAX"

"STARRED"

for the

"BABY THREE"

THE "POLAR COMPAX" condenser, specified for this receiver was specially designed for use as either a TUNING or REACTION condenser. Built of highest quality materials, it is marvellous British value.

·0005

2/9

·0003

2/6

From all Dealers.

24-PAGE CATALOGUE FREE



WINGROVE & ROGERS, LTD., 188-9 STRAND, W.C.2. ♦ OLD SWAN, LIVERPOOL

Please mention "Amateur Wireless" when Corresponding with Advertisers



A weekly review of new components and tests of apparatus conducted by J. H. Reyner, B.Sc., A.M.I.E.E.

Blue Spot 100U Speaker

THE name of Blue Spot has come to be associated with all that is best in moving-iron type speakers. It was thus with considerable interest that we received for test one of their new British-made 100U inductor-type speaker chassis. This type of speaker has recently come very much to the fore, and it is safe to say that the results obtained with these speakers are comparable and, in some cases better, than can be obtained with some of the moving-coil instruments at present on the market.

As readers will know, this type of speaker is, to some extent, similar to a moving coil, one essential difference being, of course, that in the case of the inductor-type speaker a small, lightly damped iron armature is caused to move the diaphragm, instead of the coil in the case of the other

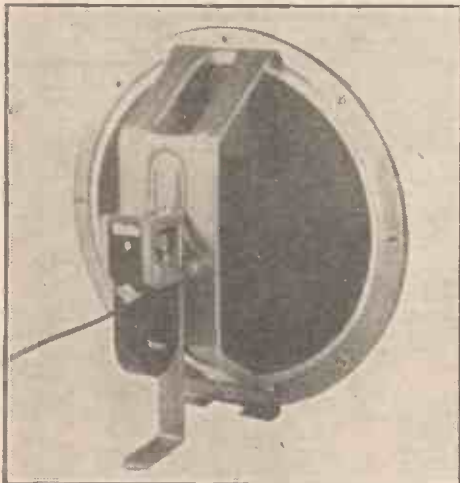

Popular inductor speaker—Blue Spot type 100U

type of speaker. This speaker employs a large U-shaped permanent magnet, on to the ends of which the pole pieces, which are solid and specially shaped, are screwed. The armature, which is riveted on a thin strip of some non-magnetic material, is normally positioned just below the centre of the pole pieces. The energising winding is wound on a bobbin through the centre of which the armature passes. With this type of construction it is impossible to make the loud-speaker rattle, whatever the input.

The unit is screwed to a very rigid metal frame, which carries lugs to enable the speaker to be screwed down to the cabinet or behind the baffle board with which it is to be used. The paper diaphragm is suspended from a metal ring, this being spot welded to the frame of the speaker. The

diaphragm is suspended from the ring by means of some type of fabric. The cone has an overall diameter of 9 in. and a depth of about 3 in.

On test the speaker gave very pleasant results, the response being good up to about 3,500 cycles and down to 100 cycles, while reasonable output was obtained as low as 50 cycles. The sensitivity was also good, making the speaker quite suitable for the most modest of receivers. However, to use the speaker to its full advantage it is advisable to supply it with at least half a watt from the output stage. The speaker can be recommended.

Good L.T. Switch

AN interesting switch which we have recently received for review is that manufactured by Messrs. The Jewel Pen Co., and known as type RD35. The special feature of this switch is that it is of the dead spindle type, having two separate make and break combinations, the contact springs being so arranged that one set breaks slightly in advance of the other. The contact pressure is good, which is an important point, and no trouble from dirt should arise.

The fairly heavy pressure of the contacts ensures a definite on-and-off position, but at the same time the action of the switch is quite smooth.

The body and knob of the switch are of ebonite, as is the insulation between the moving contacts. The terminals, which are mounted on the body of the switch, are of a good size and thus allow easy wiring. The switch is arranged for one-hole mounting, a drilling $\frac{1}{8}$ in. in diameter being required. The construction is good and at a price of 2s. the switch is good value for money.

Bryce AB66 Transformer

WE are reporting this week on the Bryce mains transformer, type AB66, which has been designed specially for use with the "A.C. Britain's Super." This transformer is one of a comprehensive range manufactured by this firm and, in common with all, the finish and the construction are excellent.

THE "1932 ETHER SEARCHER"
NEXT WEEK
FULL DETAILS AND FULL-SIZE
LAYOUT

Read the announcement on page 49

A massive laminated iron core is used, being clamped by strong aluminium end plates, which are provided with lugs to enable the transformer to be mounted vertically or horizontally. The red fibre terminal board, which is mounted on top of the transformer, is screwed to lugs on the end plates. Good size terminals are used and, as these are clearly designated, there should be no danger of wrong connection.

The transformer has been designed for use on different voltages at 200 to 240-volts at 40 to 60 cycles. Three output windings are provided, having the following values: 250-0-250 at 80 milliamperes, 4 volts, 1 ampere centre-tapped intended for feeding the filament of the rectifying valve, and 4 volts 6 amperes also centre-tapped for the filaments of the valves of the receiver.

A full-load test was run on the transformer, this consisting of measuring the voltage



One of the extensive range of Bryce mains transformers. The type AB66 is described in the accompanying report

across each output at various load currents; in all three cases this was done with a full load on the remaining windings of the transformer. The following results were obtained. The rectifier L.T. winding gave 1 ampere at 3.7 volts, while the main L.T. winding gave 6 amperes at 4 volts. The high-tension winding gave its rate voltage with a load of 16 milliamperes, whilst with its rated load of 80 milliamperes, the voltage was 248.0-248.

The no-load power loss was measured to be only 2 watts, which is a good figure for this type of transformer. The input throughout the test was 240 volts at 50 cycles.

It will be seen from the above results that the transformer is sensibly up to its rating and it should give good service.

LARGER AND BETTER THAN EVER!

THE NEW
"LANGMORE"
RADIO-GRAMOPHONE
CABINETS
(No. G1)

These cabinets are very strongly constructed of selected Oak. Size overall, 3 ft. 6 in. high by 21 in. wide by 15 in. deep.

THE TOP SECTION. Size, 4½ in. high by 18 in. wide by 14 in. deep, gives ample accommodation for gramophone or pick-up.

THE CENTRE SECTION. Size, 10 in. high by 18 in. wide by 14 in. deep, is for the Wireless Set, to take a panel either 18 in. by 7 in. or 18 in. by 8 in.

THE BOTTOM SECTION. Size, 16 in. high by 18 in. wide by 13½ in. deep, gives accommodation for Loud-speaker and Batteries.

Wooden Panels to fit, with oval aperture, 12 in. by 5½ in. 2/- extra.

The whole of the back is enclosed by double doors, so that all parts are easily accessible. ALL are fitted with hinged top, heavy platform to take a 12-in. turntable for the Gramophone, and a substantial baseboard for the Wireless Set.



Price 49/6 each

Packed FREE and sent Carriage Paid to any address in Gt. Britain.

Trade Inquiries Invited.

BEAUTIFULLY FINISHED
:: JACOBAN OAK ::

THE MISCELLANEOUS TRADING Co. Ltd.
13 & 17, NEW OXFORD STREET, LONDON, W.C.1
Phone: Holborn 4894.

ALL YOUR RADIO RESISTANCE REQUIREMENTS COVERED BY....

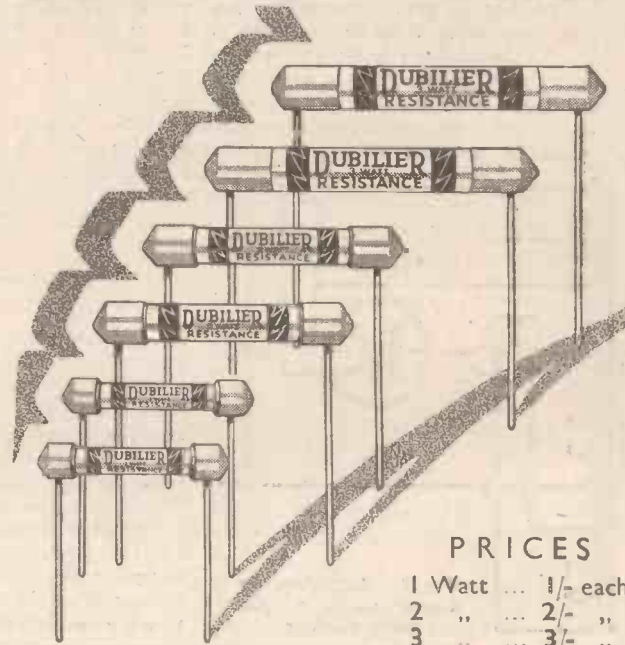

PRICES

1 Watt ...	1/- each
2 " ...	2/- "
3 " ...	3/- "

DUBILIER METALLIZED RESISTANCES

These Dubilier resistances are made under a patented process in One, Two and Three watt types and are available in values to suit every requirement.

They are suitable for voltage dropping, decoupling and providing automatic grid bias voltages, and wherever a reliable resistance is required.

They can be mounted in clips; but connecting leads are fitted in addition.

DUBILIER CONDENSER CO. (1925) LTD.

Ducon Works,
Victoria Rd., N. Acton, London, W.3

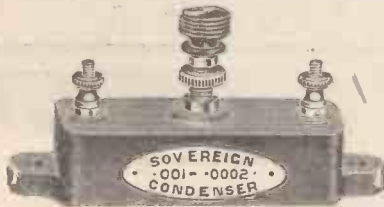

IN THE BABY THREE

Kit season has started and once more Sovereign are prominent amongst the designer's lists of chosen parts. The unit chosen for this is one essentially for selectivity, and like all Sovereign Components, can be relied upon for utmost efficiency and consistent service. Make Sovereign your choice for the coming season. If your dealer cannot supply, send direct.

Sovereign J. Type Compression Condenser, as specified in the Baby Three, in bakelite case with nickelled fittings, .0003 mfd. max. Complete 1/3

Send for the Sovereign Catalogue, of Radio Components (2nd Edition) and see how much you can save by using Sovereign.

USE SOVEREIGN WHEREVER YOU CAN

SOVEREIGN PRODUCTS, LTD.
52/54 ROSEBERY AVENUE,
LONDON, E.C.1.
Clerkenwell 2788, 9



THE GAS-FILLED RECTIFIER

Some Practical Information on the Working of a Novel Type of Rectifier
By J. H. REYNER, B.Sc., A.M.I.E.E.

THE limit of current obtainable with the ordinary small-power rectifier valve of to-day is about 120 milliamperes. If one desires to obtain a current greater than this, it is necessary to employ some form of gas discharge tube. The Marconi and Osram GU1 valve is a typical example, this valve being able to stand up to 1,000 volts on the anode and deliver a current up to 250 milliamperes. The fact that the valve will stand 1,000 volts applied potential is apt to create the impression that it should not be used for smaller voltages. This,

however, is not the case and it may be used on voltages of the order of two to three hundred, such as are customarily employed for small power work.

The gas-filled rectifier is not a novelty. It has been used for some time for the production of relatively large currents at low voltages. Some of the early accumulator-charging stations made use of these valves, although the more convenient metal rectifier has largely ousted them. These valves contain a hot cathode or filament and an anode usually in the form of a simple plate. These two elements are enclosed in a bulb which is exhausted and filled with mercury vapour at a low pressure.

Recent research has extended the use of this type of valve to high voltages. The fundamental principles remain the same. There is the hot cathode which, however, is made somewhat larger, being in the form of a spiral of wire about 1/4 in. in diameter. This is heated with current from a 4-volt supply until it glows at a red heat. The anode is a flat plate placed half an inch or so away from the cathode, and the whole is

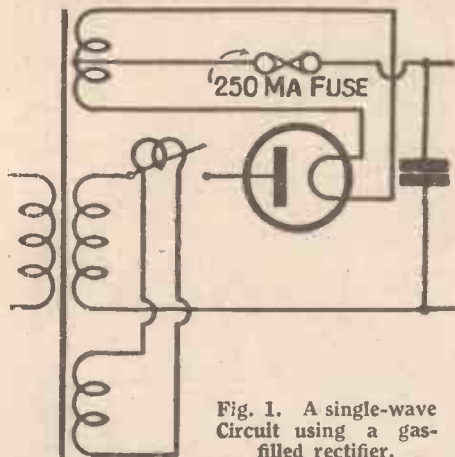

Fig. 1. A single-wave circuit using a gas-filled rectifier.

The Arc Characteristic

Such an arrangement has the characteristics of an electric arc. Approximately 15 volts potential difference must be applied across the rectifier before any current will flow, but once the discharge has started it can be maintained on quite a small voltage and, in fact, if there is not some limiting arrangement in series with the circuit the current which flows is so heavy as to damage the valve and perhaps spoil it altogether. It is thus a fundamental necessity when using this class of rectifier to incorporate some form of limiting device to keep the current within safe bounds.

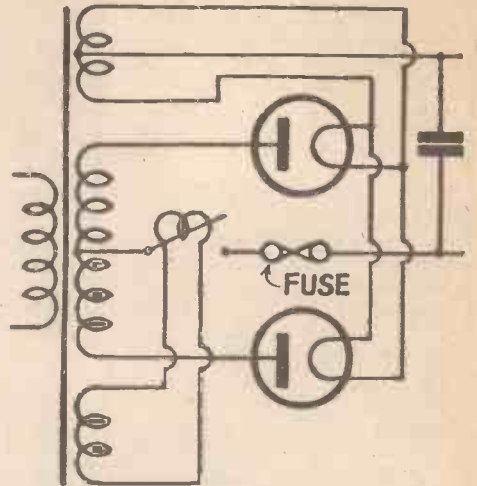

Fig. 2. Here is a double-wave rectifier circuit

WEARITE COMPONENTS

for A.C. BRITAIN'S SUPER

A.C. TRANSFORMER
H.T. 250-0-250v
L.T. 2-0-2v. 6 amps.
L.T. 2-0-2v. 1 amp. Price **32/6**
(please state mains voltage and frequency when ordering).

VOLUME CONTROL
Q35. 50,000 ohms wire wound. Price 4/-

SMOOTHING CHOKE
HT2. 20 henries carrying 75 m/a. Price 21/-

VALVE HOLDERS
4 or 5 pin type. Price 1/3

GRIDLEAK HOLDER. Price 6d.

EARTH TUBE - Price 3/6



SUPER-HET COILS
(Patent No. 349403) as illustrated
New O1 Unit, two range
2 O.T.2 Bandfilters
1 O.T.1 Bandfilter. Price **50/-**

Write for Free Illustrated Lists and Special Leaflets
WRIGHT & WEAIRE LTD.,
740 HIGH ROAD, TOTTENHAM, N.17. 'Phone: Tott. 3847/8/9

enclosed in mercury vapour inside the glass bulb. When the discharge is taking place a characteristic mauve glow is obtained, as is usual with any discharge in mercury vapour.

Current Consumption

The cathode takes 3 amperes at 4 volts. This is necessary because the wire of the cathode has to be much stouter than the ordinary filament in a rectifying valve. The action of this type of discharge tube is quite different from that of the ordinary thermionic valve. The latter works by virtue of the emission of very light particles of electricity or electrons from the hot filament, these electrons boiling out of the filament just as particles of water vapour will come off the surface of boiling water. In the present instance, however, the gas inside the valve is split up into relatively large particles of electricity known as ions. The gas is said to be ionised, and these electrical charges move across from the anode to the cathode under the influence of the applied voltage, the total current being built up of the accumulated effects of these various ions.

The ion, however, is a much more bulky particle of electricity than the electron, and by the time it reaches the cathode it is travelling fairly fast, particularly if there is a high voltage on the valve. The result is a very definite mechanical shock to the atoms constituting the cathode, and unless the wire is really heavy it will break in quite a short time, due to the heavy bombardment of the ions.

SCREEN-GRID VALUES

There are many types of screen-grid valve available with widely differing characteristics, but average values are given

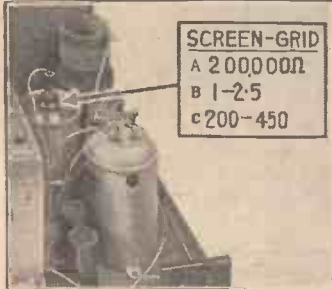

here for a set in which there is only one screen-grid stage. A is the impedance, B the mutual conductance and C the amplification factor.

The second feature of these high-voltage discharge tubes is that the discharge must not be started until the filament has really warmed up. A period of forty seconds at least should be allowed after the filament has been switched on before the H.T. is applied to the anode. Where possible, a somewhat longer time should be allowed to be on the safe side.

There are on the market several devices specially designed for this type of valve, and so arranged that the application of the high tension is automatically delayed for a period of forty-five seconds or so after the circuit is switched on in order to give the valve filament time to warm up. Such a

device is the Varley delay switch, which operates on the thermostatic principle and was reviewed in these columns recently.

How the Valves are Used

The valves are used in exactly the same way as the ordinary single-wave rectifier. Fig. 1 shows a single-wave circuit and Fig. 2 a double-wave circuit. These circuits will give a quarter and half an ampere respectively, which is a fairly healthy amount of D.C. to obtain from a simple inexpensive rectifier. The delay switch is shown in both instances, as also is a fuse to prevent the valve from being damaged. The load to which the rectifier is to be connected should, of course, be so arranged that the current cannot be seriously in excess of the rated maximum output current, even under faulty conditions. If there is any smoothing or decoupling apparatus, this in itself tends to limit the current in the event of an inadvertent short circuit in the later stages of the receiver, but it is best to insert a small fuse rated to blow at about twice the normal current in order to protect the valve from any damage.

Smoothing circuits must, of course, be used with these valves just as with the ordinary rectifier valve. It will be found, however, that the smoothing required is somewhat more extensive than usual owing to the peaky character of the discharge current through the valve. Where a 2-microfarad condenser would do with an ordinary thermionic rectifier, probably a 4-microfarad would be required for the same degree of smoothing with a gas-discharge tube, but this is very largely a matter for individual experiment. The ratio of A.C. current supplied by the transformer to the D.C. output is about 2 to 1 for a double-wave arrangement and between 2.5 and 3 to 1 with a single-wave circuit.

Using the Fig. 2 circuit recently some trouble was experienced with a most unpleasant interference of the "tearing calico" types, which was evident towards the bottom of the wave range and became very pronounced when any carrier wave was tuned in. This, however, was ultimately found to be due to high-frequency currents, which were either generated by the valve or were being passed on from the transformer. The insertion of two high-frequency chokes in the output leads, as shown dotted in Fig. 2, overcame the difficulty completely. The chokes used, of course, were special mains H.F. chokes designed to carry the abnormally large current, such as are made by Messrs. A. F. Bulgin, Wright & Weaire, and others.

Although work on the new 15-kilowatt station to serve the Lille district had been started, it is now stated that it has been stopped by order of the French State authorities. The new station was to be built at the expense of the local municipalities, but, in view of the probable adoption of the General Ferrié plan for the re-organisation of the broadcasting system in France, the Ministry of Posts and Telegraphs has agreed to undertake the construction of a 60-kilowatt transmitter on the same site.

IMMEDIATE DELIVERY OF EVERYTHING RADIO C.O.D.—CASH—H.P.

MANUFACTURERS' KITS

TELSEN THREE Kit "A" less valves and cabinet. Cash or C.O.D., £1/19/6 or 8 monthly payments of 5/6.

V.3 RADIO FOR THE MILLION with valves less cabinet. Cash or C.O.D., £5/17/6 or 10/- deposit and 11 monthly payments of 10/10.

COSSOR EMPIRE MELODY MAKER Model 234. Complete with valves and cabinet. Cash or C.O.D., £6/15 or 10/- deposit and 11 monthly payments of 12/6.

OSRAM NEW MUSIC MAGNET FOUR Complete with valves and cabinet. Cash or C.O.D., £10, 15, 0 or 12 monthly payments of 19/8.

FORMO TRIPLE-WAVE THREE Complete with triple-wave switch-operated coils and valves. Cash or C.O.D., £3/5, or 12 monthly payments of 5/11.

READIRAD METEOR III Less valves and cabinet. Cash or C.O.D., £3/15, or 12 monthly payments of 6/11.

BABY THREE
As described this week.
KIT "A" Author's Kit less Valves and Cabinet
CASH or £1 : 18 : 2
C.O.D. only
Set of Valves as specified - £1/7/6
Any parts for this set can be had separately. If value over 10/- carriage paid. C.O.D. we pay post charges.

W.B. PERMANENT MAGNET MOVING-COIL SPEAKER P.M.3. 4/10 Send
Complete with 3-ratio input Transformer. Cash only
Price, £2/12/6. Balance in 11 monthly payments of 4/10.

AMPLION M.C.6 MOVING-COIL SPEAKER, Send
permanent magnet, with output transformer. 6/2
Complete. Cash Price, £3/7/6. Only
Balance in 11 monthly payments of 6/2.

BLUE SPOT SPEAKER UNIT AND CHASSIS, Send
TYPE 100U. 5/5
Cash or C.O.D. £1/19/6. Only
Balance in 7 monthly payments of 5/5.

REGENTONE H.T. ELIMINATOR for D.C. Mains, Send
Type D.C.1. Adjustable S.G. Tapping; Detector 4/9
and Power. 25 m/A. Cash Price, £1/15/-. Only
Balance in 7 monthly payments of 4/9.

ORMOND PERMANENT MAGNET MOVING-COIL CHASSIS (No. 464). Send
With input transformer. Cash Price, £3/5/-. 5/11
Balance in 11 monthly payments of 5/11. Only

ATLAS A.C. ELIMINATOR, TYPE A.C.244. Send
Three tappings, S.G., detector and power. Output, 5/6
120 volts at 20 m/A. Cash price, £2/19/6. Only
Balance in 11 monthly payments of 5/6.

CELESTION P.P.M. PERMANENT MAGNET MOVING-COIL SPEAKER with impregnated diaphragm and dual-impedance input transformer, cash or C.O.D. £2/7/6. Send
Balance in 7 monthly payments of 6/6. 6/6 only

Send 3d. postage for 116-p. Catalogue.

PETO-SCOTT
77 CITY RD., LONDON, E.C.1. CO. LTD.
Phone: Clerkenwell 9406-7-8.
62 High Holborn, London, W.C.1. Phone: Chancery 8266.



IN MY WIRELESS DEN

Weekly Hints — THEORETICAL
CONSTRUCTIONAL & BY
W. JAMES

Charging at Home

IT is easy enough to charge an accumulator from direct-current mains, but care must be taken in order to avoid shocks.

The battery can be connected in series with a lamp of sufficient wattage to pass enough current or, in the case of a battery which has a fair capacity, it may be joined in circuit with an electric fire.

On a 200-volt circuit a 100-watt lamp will pass practically half an ampere through a 2-volt cell.

If the cell is connected in the negative side and the positive side of the supply is the one most nearly at earth, a smart shock may be obtained if the battery is touched. It should be insulated from earth and be placed in the main nearest earth potential.

The main can be found by testing with a lamp, joining one side to earth and the other first to one main and then to the

other main. Join the accumulator to the side which, when it had the lamp joined to



SERIES



PARALLEL

Flexible resistances may be used in series (above) or parallel (below) to fit various circuit occasions. The accompanying paragraph describes the arrangements

it, gave the smallest light, or perhaps no light at all. Always disconnect the accumu-

lator from the receiver before connecting it for charging.

Using Spaghettis

The amount of the current that can safely be carried by a resistance, such as one of the flexible type now so widely used, depends upon the size of the wire and the cooling.

It is usual to rate a resistance at such a value of current that it does not become warm when carrying the full load current. If too much current is passed through the resistance it will become hot and may burn out. It is, therefore, necessary to use a resistance that will carry the current with safety.

Sometimes a resistance of the right value and current capacity is not available, but two or more resistances can be used. If
(Continued on next page)

REDUCED PRICES for BELLING-LEE FUSES



BELLING-LEE WANDER-FUSE—fuse and wander plug combined. Lies flat

on battery top. Takes no extra space. Complete with 150 m/a fuse. REDUCED from 1/6 to 1/-

BELLING-LEE SINGLE BASEBOARD FUSE-HOLDER. The best method of mounting fuses inside any set. Complete with 1/2-amp. fuse. REDUCED from 1/6 to 1/-

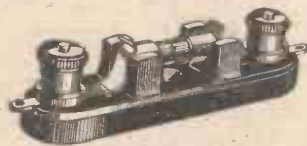

FLEXIBLE LEAD FUSE-HOLDER, short type, with 1/2-amp. fuse, 1/- (Longer type with mains fuse, 1/-).

TWIN BASEBOARD FUSE-HOLDER, with two 1-amp. fuses for mains leads 3/6

SPARE FUSES, in two lengths, H.T. ratings (60 m/a., 150 m/a. and 1/2 amp.), 1/2 in. long; mains ratings (1, 2, and 3 amp.), 1 1/2 in. long.

All ratings are sold at 6d. each.

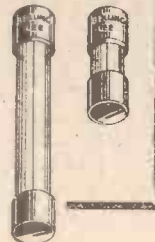

BELLING-LEE
FOR EVERY RADIO CONNECTION

Advt. of Belling & Lee, Ltd., Queensway, Ponders End, Mdx.

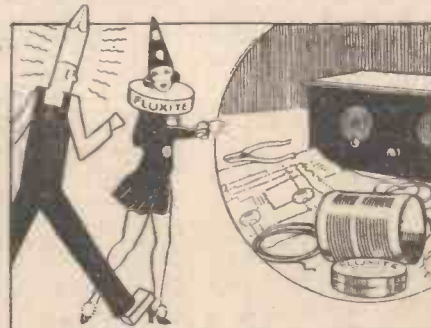

"We're Fluxite and Solder, The reliable pair, Famous for Soldering—Known everywhere! We SOLDER all 'connections' Without any fuss, So, wherever there's WIRELESS, You're bound to find US!"

See that Fluxite and Solder are always by you—in the house, garage, workshop—anywhere where simple, speedy, soldering is needed. They cost so little, but will make scores of everyday articles last years longer! For Pots, Pans, Silver, and Brassware; RADIO: odd jobs in the garage—there's always something useful for Fluxite and Solder to do.

All Hardware and Ironmongery Stores sell Fluxite in tins, 6d., 1/4 and 2/8.

ANOTHER USE FOR FLUXITE
Hardening Tools and Case Hardening. Ask for Leaflet on improved method.

NEW "JUNIOR" SIZE, 4d. per tin FLUXITE SOLDERING SET

Simple to use and lasts for years in constant use. Contains special "small-space" soldering iron with non-heating metal handle; pocket blow-lamp. Fluxite, Solder, etc.; and full instructions.

COMPLETE, 7/6, or LAMP only, 2/6.

FLUXITE, LTD.
(Dept. 326)

ROTHERHITHE, S.E.16

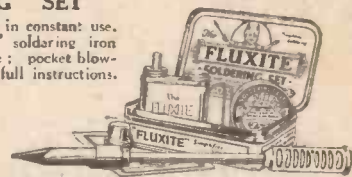

ALL MECHANICS WILL HAVE

FLUXITE

IT SIMPLIFIES ALL SOLDERING

"IN MY WIRELESS DEN"

(Continued from page 64)

two resistances are joined in series, as in the accompanying diagram, the total resistance is equal to the sum of the separate values.

With a 20,000 and a 30,000-ohm in series, the total resistance is 50,000 ohms. The current capacity is that of the one having the lowest rating.

When resistances are placed in parallel, the total value of the current passed is the sum of the separate currents passed by the resistances. With two 30,000-ohm resistances having a current carrying capacity of 10 milliamperes, connected in parallel, the effective resistance is 15,000 ohms and the total current that may be carried amounts to 20 milliamperes.

Are Your Values Correct?

In quite a number of old sets a grid condenser of .0003 microfarad and a leak of 2 megohms are fitted.

These values were widely used at one time, but it is now generally agreed that better results may be obtained when the condenser is of less capacity and the grid leak of a little lower resistance.

In many instances the results will be improved by taking out the .0003 microfarad and fitting a .0001 microfarad. The 2-megohm grid leak may remain if the condenser is of .0001 microfarad, but the higher notes will be strengthened if the leak is reduced to .5 megohm.

When a pentode is used the results may be satisfactory with the 2-megohm leak, and this value might also be the best when reaction is used in the detector circuit. If the set is used chiefly for receiving the local stations the lower value of leak will probably be worth using.

High-tension Matters

Dry batteries last a very long time when the current taken from them is small. Many amateurs have found this and take steps to reduce the value of the high tension to as little as possible.

They increase the grid bias of the power stage, for example. This reduces the current taken by the power valve. It is surprising, as a matter of fact, how greatly the power valve can be over-biased without the reproduction being affected.

I am, of course, referring to sets made from inexpensive parts and having a small loud-speaker. The quality is never very good and when the set is adjusted for minimum high-tension current, is very little worse. A test that all users of batteries may well make is to start with the value of grid bias suggested by the makers of the power valve and to increase the bias until the quality or volume suffers.

Critics of the critical! The agitation about the Glasgow broadcast programmes waxes as hot as ever. It has recalled to mind that only a year ago, when the Scottish headquarters of the B.B.C. were transferred from Glasgow to Edinburgh, there was a great outcry that this was taking away Scottish broadcasting from Glasgow. To-day the complaints are chiefly in a reverse direction—that all the Scottish broadcasting goes to Glasgow.

SPRINGS POSITIVELY SECURED

NICKEL SILVER SPRING CONTACTS

POSITIVE SNAP ACTION

POLISHED CONTACTS

TAPERED SLEEVE

THICK SPINDLE WITH LONG BUSH

OPTIONAL CONNECTIONS

INDICATING FRAME

BUSH ADJUSTABLE TO PANEL

BLACK OR MAHOGANY FINISH KNOB

SCREWHEADS COUNTERSUNK

BAKELITE BASE

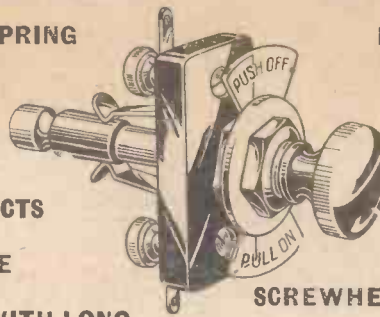

Bulgin originated the Push-Pull Radio Switch in 1924, and every year has seen improvements incorporated, both in design and operation. No other push-pull switch incorporates all the good points enumerated above. Numerous imitations only serve to emphasise the superiority of Bulgin Switches, which are increasingly popular.

Push-Pull Switch (above)	S.22	1/6
Three Spring Wave-change (bottom right)	S.36	1/9
Quick Make and Break "On-Off" (bottom left)	S.15	1/9

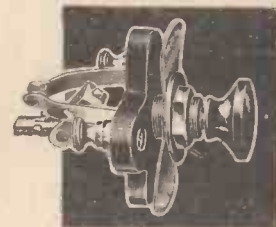
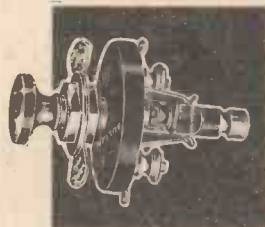

A. F. BULGIN & Co., Ltd.,
Abbey Road, Barking, Essex.
Telephones: Grangewood 3266 and 3267

London Showrooms: 9, 10, 11 Cursitor Street, Chancery Lane, E.C.4.

Telephone: Holborn 2072

BATTERY SETS

MADE

ALL-ELECTRIC

FOR

9/2

and 11 payments of 8/8 or

CASH PRICE £4:15:0



TYPE G.B.1

H.T. 150 v. at 15m/a. or 120 v. at 20 m/a. Also S.G. and Det. Tappings.

G.B. 3 Tappings up to 12 v. Independent of H.T.

L.T. 2, 4 or 6 v. Trickle Charger.

Similar to above but larger output.

—TYPE G.B.3

TANNOY mains units incorporate independent G.B. Pat. No. 353375.

Write for particulars

TANNOY

PRODUCTS

Dalton St. :: West Norwood

TEL.: STREATHAM 6731/2

IF YOU ARE CONTEMPLATING BUILDING A SET—STUDY THE BLUEPRINT LIST ON PAGE III OF THE COVER. THERE IS A SET FOR EVERY NEED

To ANNOUNCER
CONTROL ROOM
TELEPHONE SWITCHBOARD

S.O.S.

To be Broadcast.

Time... 2 P.M.

Date... 31st September, 1931.

Will GEORGE PERCIVAL COX, a leather
worker, last heard of in Warwickshire about five
years ago, go at once to the Hospital,
where his mother Mrs. Elizabeth Cox, is dangerously
ill.

Sent in by... Edwin James Cox, Waterside Terrace, Mundesley.

Confirmed by... Dr. John Smith, Mundesley 59516.

TO BE RETURNED TO TALKS.—News Dept.

B.B.C./170

S
O
S!

Night after night with unflinching regularity the familiar SOS appeal is made before the news bulletin is issued. In the January issue of WIRELESS MAGAZINE, now on sale, an authoritative article deals with the methods of handling SOS appeals at B.B.C. stations, together with full particulars of the methods of collecting world news for the bulletins. Get your copy to-day; don't miss this really exclusive feature.

WIRELESS MAGAZINE

OTHER SPLENDID ARTICLES IN THE JANUARY ISSUE

16-page "World Wide" Reception Supplement

Three More Sets for You to Build—
The New Economy Two (Costs only 65/-); The Ether Rover and the 1932 Super 60

The B.B.C. in 1931

This "Featherweight" Question—Light Weighting for Pick-ups Discussed

British Television—

What is Being Done, by H. J. Barton Chapple

Future Possibilities, Alan Hunter

New Ideas in Tuning, by P. K. Turner, M.I.E.E.

Is Valve Progress on the Wrong Lines?

**ON SALE TO-DAY OF ALL BOOKSTALLS
PRICE 1/-**



EVERLASTING POWER
1/4d. PER HOUR!

A Mains Unit specially designed for any type of receiver—The Heayberd Model C.250—gives hum-free results. Assembled in neat metal case—Westinghouse Rectification. Requires wiring-up only—giving you the opportunity to thoroughly know your unit.

Alternative outputs—60 ma. at 200 or 250 volts. Tappings: 60/80v., Var. S.G. 0-150v. Var. 100-200v. Var. and 250v. fixed. **150%**

Send 3d. stamps for illustrated list of the full range of Heayberd Mains Units & Transformers.
10, FINSBURY STREET, LONDON, E.C. 2.

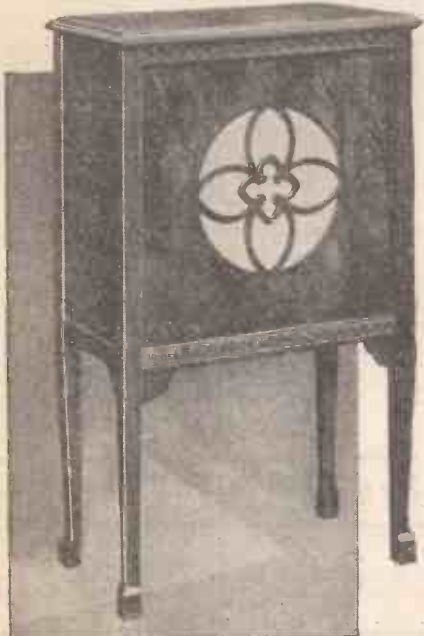
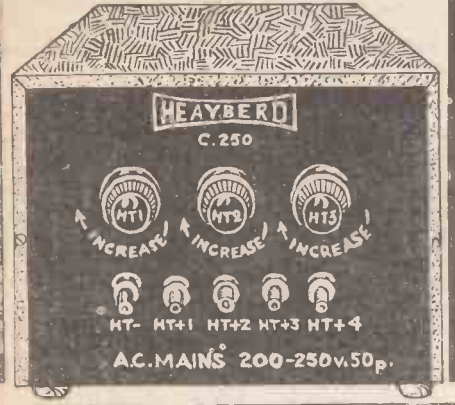

A CABINET OF PRACTICAL DESIGN

The Camco "Regent" Speaker and Battery Cabinet is a remarkably neat and attractive piece of furniture. It will accommodate your batteries and eliminators as well as the loud-speaker and is built to avoid resonance. In Oak £3. Inside dimensions 21 x 20 x 11 ins. deep. Height 38 ins. You cannot do better than house your Speaker and Batteries, etc., in a "Regent" Cabinet. Write for FREE copy of the new 24-page Camco Catalogue



CARRINGTON MFG. CO. LTD., Showrooms: 24, Hatton Garden, London, E.C.1. Phone: Holborn 9202. Works: South Croydon.

NAME _____
ADDRESS _____

A.W.28

WHAT'S WRONG WITH TELEVISION?

My Reply to Mr. Robinson

By H. J. Barton Chapple, Wh. Sch., B.Sc.

I READ Mr. Robinson's article, which appeared in AMATEUR WIRELESS dated November 14 with rather mixed feelings. Quite frankly he seems to have confused the issue. In its strictest sense I maintain there is nothing wrong with television.

It is unfortunate that Mr. Robinson attempts to question the number of people who are conducting television experiments in this country. He will appreciate that there are hundreds of amateurs who have turned to television as an outlet for their constructive capabilities.

We all appreciate that the limited programme time is definitely a big drawback, but why should there be limited programmes? In America television is on the air for several hours a week and it ought to be possible in this country to fit the transmissions into more convenient hours. With the high-powered alternative programmes now offered to the man who listens-in, surely he would not mind the allocation of one of these stations to the transmission of vision in the evening.

Short-wave Possibilities

The short and ultra-short waves do offer one solution, but why should the science of television, with its almost incalculable future prospects, be "sent down" amongst the amateur bands? Leaders of industry in America have given it as their considered opinion that television will soon be within the reach of thousands of people (millions is the term used).

The term "frequency compression" is somewhat of a misnomer, something like trying to get a quart into a pint bottle. The real trouble is a failure on the part of individual writers and technicians to understand thoroughly the basic principles involved.

Upkeep Costs

We now come to the question of cost as detailed by Mr. Robinson. The complete Baird "Televisor" is retailed at 18 guineas, but there is a Senior Kit at 12 guineas and a Junior Kit at £7 12s. 6d. In the case of the last two, it is quite a simple matter for anyone to assemble these himself. Apart from this, however, I can quote hundreds of instances where the enthusiast has made up his own disc, sometimes from sheet metal, but often from cardboard or strong cartridge paper. To drive this disc motors have been acquired that normally did service for the sewing machine, vacuum cleaner, Meccano outfit, and so on. This, together with an ordinary type neon lamp, has enabled the enthusiast to see what is

happening in the studio from afar. He has been thrilled, and immediately set to work to improve his apparatus.

It is incorrect to state that the radio receiver to be used in conjunction with the vision apparatus must be built to a scale of perfection which is considerably in advance of that required for the best sound reproduction as we now know it. This is a complete mis-statement of fact and is liable to do much harm if left unchallenged. I have on many occasions used everyday commercial wireless receivers made by manufacturers of repute and obtained images which were quite satisfactory. Surely this in no way suggests a power supply of 400 volts and 120 milliamperes. If the output valve of the wireless receiver used is incapable of giving sufficient voltage to strike the neon and provide its normal running current of 25 milliamperes, then an external source is required to couple on to the set employed. This additional piece of apparatus means a voltage of 200 and an output of 25 milliamperes. If this figure is added to the requirements of the wireless receiver itself, the total output is considerably less than that quoted by Mr. Robinson.

Admittedly the images from the present type Televisor are not large, but the shape of the image area is excellent for head and shoulder transmissions and also good for full-length images in which one or two people are shown at the same time.

Programmes

We now come to Mr. Robinson's final criticism, namely, the programmes. One would imagine from Mr. Robinson's remarks that comedians, soubrettes, and people of that kind have constituted the bulk of the programme material for Baird television transmissions. To prove that this is not so let me mention just a few of the other items taken at random which have been included within the last few months. There have been health exercises and physical development, competitions, sketches, paper magic, phrenology, shadowgraphy, illustrated talks on all forms of sport, the care of dogs, marionettes, contortionists, novelty musicians, cartoon features, folk songs with appropriate dress, and so on. This list could be extended considerably, but I think those mentioned will suffice to show that the programmes are not quite so one-sided as one might be led to believe.

It is now stated that the power of the new Milan station under construction at Siziano will be 75 kilowatts and will therefore equal that of the Rome transmitter.

READERS IDEAS

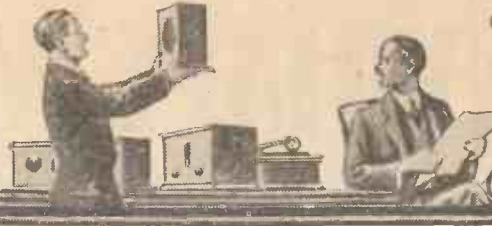

AND QUESTIONS

"Britain's Super" Band-pass

SIR,—I have constructed "Britain's Super" and am experiencing rather weak reception. I have adjusted the anode voltages to the various values to give the best results and still volume is very poor. Can you assist in any way so that I may get more volume. The band-pass coil has an extra terminal in the centre marked R. There is no such terminal shown for the coil in your wiring plan.

R. T. (Putney).

It seems you have either not ganged up your band-pass circuits correctly or that your band-pass coil is faulty. A reaction winding has been added to the coil, by the makers, since the coil was first used by us. This reaction winding is not detrimental to the working, and the terminal marked R should be disregarded. To test your receiver without the band-pass coil in use, we suggest you disconnect the aerial from its present terminal and connect it via a .0002-microfarad capacity fixed-condenser to the operating grid of the bi-grid valve. You may now tune the receiver as for a simple tuned aerial set. If you get satisfactory results in this way, try adding the band-pass arrangement by connecting the aerial to its proper terminal. By re-trimming the tuning condensers, you should have no difficulty in getting satisfactory results. Should signals still be poor, suspect your band-pass coil. You might try connecting terminal R to terminal E on the coil before finally suspecting the coil of being faulty.—ED.

"A.C. Century Super"

SIR,—I have been experimenting with the "A.C. Century Super" for some time and have so far failed to obtain the results you claim. Frame aerial tuning is very flat and I am unable to get more than about eight stations on the speaker. The receiver is built with the components mentioned first in the list of parts and, so far as can be seen, all components are of the correct value. Can you suggest what may be wrong? All valves have been specially tested by the makers.

S. K. (Croydon).

Flat tuning in the frame aerial circuit points to your first detector valve not "detecting." This is probably due to the fact that the valve is getting too much voltage on its anode. We suggest you try replacing the 20,000 ohms spaghetti resistance in the plate circuit of the detector with another resistance of 50,000 or 60,000 ohms. This resistance should reduce the voltage and the current to the correct value and correct the poor working of your set. If you have a milliammeter available, we suggest you test the current consumption of both the first detector and the oscillator valves. The reading for the first detector valve should be .2 or .3 of a milliampere, with the oscillator valve withdrawn from its holder. The oscillator valve itself should read 3 milliamperes.—ED.

"Ploppy" Reaction

SIR,—I have a three-valver which, until recently, worked extremely well. About a week ago volume of signals on the distant stations dropped and I now have to force reaction to get reception of any of the foreigners. Reaction now seems to be ploppy and the set has to be on the verge of oscillation before signals are received. The accumulator has been re-charged and the H.T. battery gives a reading of 90 volts, originally 120 volts. As the receiver was originally worked from a single 60-volt battery, I cannot see that the H.T. battery can account for the trouble. All wiring connections have been checked and seem sound. Can you assist me?

C. P. (Kent).

The trouble you are experiencing certainly points to your H.T. battery having become exhausted. Although your receiver worked satisfactorily with a 60-volt battery when first built, it must be realised that a new 60-volt battery can give plenty of current and when only 60 volts are applied to the anode of a valve, it will only demand a very small amount of current. If you apply 90 or 120 volts to the anode it will consume double the amount of current as when only 60 volts are applied. When the H.T. battery begins to run down, not only does the voltage drop, but the ability to supply a constant flow of current fails and the battery itself develops a high-internal

resistance. All of these failings tend to prevent the valves from working properly and if you endeavour to get results by forcing reaction, you will surely experience ploppy reaction. If you have two 60-volt H.T. battery units, you could connect them in parallel, thus applying only 60 volts to the anodes of the valves. This would enable you to work your receiver as originally, but you would not get satisfactory reception for very long. It will be better for you to get a new H.T. battery of 120 volts, preferably of the triple-capacity type, and so overcome your troubles in the proper manner. To economise in H.T. battery current, you should apply as much bias to your L.F. amplifying valves as is possible, consistent with good quality and good volume reception.—ED.

Dual-range Coils

SIR,—I am moved by a recent article in AMATEUR WIRELESS by "Hotspot" on dual-range coils to bring to your notice the fact that two out of every three constructors who use dual-range coils fail to obtain satisfactory results with these on the long waves. "Hotspot" in his article tells us that a continuous winding of 198 turns is sufficient to cover these, but I do not agree, as I firmly believe that if this is the case with commercial coils, this is the reason for the poor results I experience on the long waves. Personally I think 250 would be more satisfactory for, I think you will agree that with plug-in coils you generally recommend a 250-coil and from my experience with my "Bantam Three" receiver, described by AMATEUR WIRELESS some years ago, I seriously feel that despite the fact that your Query Dept. advised me to use a larger reaction condenser, the real trouble must be that a larger number of turns would be more satisfactory. Finally, I believe if you could possibly publish this letter or part of it, you would receive a large amount of correspondence from readers who, like myself, fail to obtain satisfactory results with these coils on the long waves.

W. C. A. (Birmingham).

Constructors! SEND FOR FREE LIST OF
GODWIN'S MAINS TRANSFORMERS

When you make mains units or mains-driven sets use Godwin's Mains Transformers. There is no more certain way of guaranteeing immediate and lasting satisfaction. Engineer built to highest standards from finest British materials. All types for Valve or Westinghouse Metal Rectifiers. AV5 is for 2-cw with Manoni U.10, Philips 866 K or other equivalent rectifiers. 2-cw. Secondary voltages: 250-0-250 at 70 m/a. Centre-tapped A.C. L.T. winding giving 4 volts at 5 amps. Send today for full list of Mains Transformers and Chokes.

AV5 - £1-6-0

J. DYSON & CO. LTD.,
 5 & 7 GODWIN ST., BRADFORD,
 2 COLEMAN ST., LONDON E.C.2

Amateur Wireless HANDBOOKS

each 2/6 net.

Wireless-Controlled
Mechanism for
Amateurs

The Practical Wire-
less Data Book

THE BOOK OF THE NEUTRODYNE

by J. H. Reyner, B.Sc. (Hons.), A.M.I.E.E.

Price 1/6 net, or post free for 1/9



Of all Newsagents and Booksellers, or by post 3d.
extra, from Cassell & Co., La Belle Sauvage, E.C.4.



Rectified A.C. Mains

SIR,—I have constructed several receivers and in no case have I obtained satisfactory results. I have become so disheartened that I ordered a commercially manufactured all-mains radio gramophone, hoping that this would at least give me a number of alternative stations at good loud-speaker volume. After a week of testing, the engineers of the firm manufacturing the receiver decided that the locality was bad and took the set away again. They have promised to install for me another receiver costing round about £50. I have no objection to paying any price, within reason, for a receiver to give me the results I require, but I am afraid that the new set will not do more than the one did that was tested at my house for a week. In the circumstances, would you recommend my building a receiver at home and, if so, what receiver design would you advise me to follow? I would mention the set is required for use on D.C. mains and must be suitable for gramophone and radio and should be able to receive a fair number of foreign programmes for alternative entertainment.

K. R. (Finchley).

The mains supply in your locality is nominally D.C., but it is actually alternating current rectified by the mercury-arc system of rectification. This being so, we can only inform you that it is an extremely difficult task to get the supply sufficiently smoothed for working wireless receivers. Your close proximity to the London transmitting aeriels demands that you should have a sensitive receiver and such a receiver would naturally tend to emphasise any mains hum due to a poorly smoothed mains supply. In the circumstances we could only suggest you use a battery type of receiver in conjunction with either accumulators or dry batteries, for H.T. supply. Should you agree to do this, we would suggest you construct a receiver on the lines of the "Century Super" and adapt it for use with a gramophone, as described in AMATEUR WIRELESS, No. 475, page 93.—ED.

Is This a Record?

SIR,—I have had my "Century Super" since May and I thought it might interest you to know that my log consists of 227 stations, composed of 103 European medium waves, 21 European long waves, 48 American medium waves, 55 short-wave stations, and numerous amateurs on short waves. The only difference from standard is a pentode output valve.

C. C. (Worcester).

ADJUSTING SELECTIVITY

THE H.F. stages of a long-range set are not really required when receiving the local station. Also the sharp tuning of the H.F. circuits tends to cut the side bands and so reduce quality. An ingenious method has recently been proposed of converting one or more H.F. stages into a band-pass filter when picking up the local programme. This is effected by cutting-out the H.T. voltage on the screen grids, so as to increase the inter-electrode capacity inside the valve. The valve then serves simply as a capacity coupling between the tuned grid and plate circuits, converting these circuits into a band-pass coupling which feeds the aerial voltage directly to the detector valve.

B. A. R.

**Postcard
Radio
Literature**

GET THESE CATALOGUES FREE

Here "Observer" reviews the latest booklets and folders issued by well-known manufacturers. If you want copies of any or all of them FREE OF CHARGE, just send a postcard giving the index numbers of the catalogues required (shown at the end of each paragraph) to "Postcard Radio Literature," "AMATEUR WIRELESS," 58-61, Fetter Lane, E.C.4. "Observer" will see that you get all the literature you desire.

Speakers and Switches

MOVING-COIL speakers take up the major part of the new W.B. book, the PM1, PM2, and PM3 moving-coils and the new four-pole balanced armature job. Valve holders and push-pull switches are also described. **669**

"Square Peaks"

The Square Peak principle is applied to the new Varley sets and radio-grams, and in a catalogue just issued you can see for yourself how this makes for selectivity and easy tuning. **670**

Colvern Coils

From Colvern, Ltd., I have just received the new Radio List No. 6, which, in its forty pages, contains a wealth of hints, tips, circuits and pictorial diagrams of interest to every set builder. **671**

Gramophone Drive

The model 32 electric gramophone motor is among the parts described in the new Harlie book. Scratch filters, pick-ups, and tone controls are among the other interesting parts for radio-gram enthusiasts. **672**

Eta Valves

Here is a little folder giving details of Eta valves. Technical friends tell me that these have a fine performance and I see that now they are recommended for use with AMATEUR WIRELESS receivers in many cases. Take my tip and get through my free Catalogue Service this folder which describes the whole range. **673**

A New McMichael Portable

The "McMichael Super-range Portable Four" is now fitted with a novel tone selector control by which the natural tone can be changed merely by altering the position of the wander plug. A moving-coil mains set for D.C. mains is now produced. **674**

Battery Chargers

Fel-Ectric Radio have produced a range of low-tension chargers and trickle chargers. A folder is available giving the outputs of the six models in this range. **675**

Truvox Pick-ups

A leaflet giving details of the three models of the Truvox super pick-up has just come to hand. Gramo-radio users will be well advised to write for a free copy. **676**

OBSERVER.

DON'T WAIT

SECURE YOUR RADIO NOW ON EASIEST OF EASY TERMS

**THIS WEEK'S "A.W." SET
BABY THREE**

KIT 'A' 3 Less Valves and Cabinet, Cash only **£1:18:2**
3 valves as specified £1-7-6

MANUFACTURERS' KITS

TELSEN THREE 5/6
Less valves and cabinet. Balance in 7 monthly payments of 5/6. **WITH ORDER CASH PRICE £1 19 6**

V.3 RADIO FOR THE MILLION 10/-
With valves, less cabinet. Balance in 11 monthly payments of 10/10. **WITH ORDER CASH PRICE £5 17 6**

COSSOR EMPIRE MELODY MAKER, TYPE 234 10/-
Complete with valves and cabinet. Balance in 11 monthly payments of 12/6. **WITH ORDER CASH PRICE £6 15 0**

FORMO TRIPLE WAVE 3 5/11
With triple-wave switch operated coil, and valves. Balance in 11 monthly payments of 5/11. **WITH ORDER CASH PRICE £3 5 0**

READYRAD METEOR 3 6/11
Less valves and cabinet. Balance in 11 monthly payments of 6/11. **WITH ORDER CASH PRICE £3 15 0**

W.B. PERMANENT MAGNET MOVING-COIL SPEAKER, P.M.3. Complete with 3-ratio input transformer. Cash Price £2 12 6. Balance in 11 monthly payments of 4/10. **With order 4/10**

AMPLION M.G.6 MOVING-COIL SPEAKER, With permanent magnet, with output transformer. Complete. Cash Price £3 7 6. Balance in 11 monthly payments of 6/2. **With order 6/2**
BLUE SPOT SPEAKER UNIT AND CHASSIS, Type 100U. Cash or C.O.D. £1 19 6. Balance in 7 monthly payments of 5/5. **With order 5/5**

CELESTION P.P.M. PERMANENT MAGNET MOVING-COIL SPEAKER, with impregnated diaphragm and dual impedance input transformer. Cash or C.O.D. £2 7 6. Balance in 7 monthly payments of 6/6. **With order 6/6**

MAGNAVOX PERMANENT MAGNET MOVING-COIL SPEAKER, with 3-ratio input transformer. Cash Price £2 17 6. Balance in 11 monthly payments of 5/4. **With order 5/4**

ORMOND PERMANENT MAGNET MOVING-COIL CHASSIS (No. 464). With input transformer. Cash Price £3 5 0. Balance in 11 monthly payments of 5/11. **With order 5/11**

ATLAS A.C. ELIMINATOR, Type A.C.244. Three tappings, S.G., detector, and power. Output, 120 volts at 20 m/A. Cash Price £2 19 6. Balance in 11 monthly payments of 5/6. **With order 5/6**

REGENTONE H.T. ELIMINATOR, for D.C. mains. Type D.C.1. Adjustable S.G. tapping; detector and power. 25 m/A. Cash Price £1 15 0. Balance in 7 monthly payments of 4/9. **With order 4/9**

Send 3d. postage for 116-pp. Catalogue.

New Times Sales Co

56, LUDGATE HILL, LONDON, E.C.4
(Established 1924) Telephone: CENTRAL 2716



THE vaudeville programme on January 10 contains the names of José Collins, Haver and Lee, and Marceline D'Alroy. In a sketch by Philip Wade, entitled *The Duster*, Ian Harding, Barbara Couper, Stanley Groome, John Callis, Laura Smithson and Caleb Porter will take part.

On January 16 (the day of the Wales versus England Rugby Match at Swansea, on which Captain Wakelam is giving a running commentary), Cynan, the Crowned Poet of the Bangor National Eisteddfod, is reading his own poem "The Crowd," which was directly inspired by the England versus Wales Match at Twickenham last year.

On January 14, excerpts from the pantomime *Goody Two Shoes* at the Prince's Theatre, Manchester, will be relayed in the North Regional programme.

Baroness Luli Hohenberg, who will play the leading part in *Good-Night, Vienna*, the operetta by Holt Marvell and George Posford, which is to be broadcast on January 7 (Regional) and 9 (National), has

been offered a contract for a forthcoming London production.

Speeches on the occasion of the Annual Banquet of the Birmingham Insurance Institute, will be relayed from the Grand Hotel, Birmingham, on January 22.

A Roman Catholic service will be relayed throughout the North from St. Mary's, Lowe House, St. Helens, on January 10.

Lionel Tertis will be the solo artiste at a symphony concert by the City of Birmingham Orchestra on January 21.

A programme of music by Lionel Monckton to be heard by Midland Regional listeners on January 18 includes selections from some of his famous musical comedies.

Mr. G. D. Cunningham is to broadcast in the National programme an organ recital from the Town Hall, Birmingham, on January 27.

A new series of talks for North Regional listeners will begin on January 11. Under the title "We Northerners" a number of representatives of different trades and occupations will come to the microphone

and describe their lives. Mr. Tom Yarwood will give the first talk on "The Northwich Saltworker."

Dr. Adrian Boult is to conduct the Belfast Wireless Symphony Orchestra in a concert to be relayed from the Ulster Hall on January 30.

Dorothea Helmrich, the Scottish-Australian soprano, is to broadcast in a chamber music concert on the National programme on January 15.

On January 16, Northern listeners will be taken to the Belle Vue Circus, Manchester. Last year's relay was very successful and with Mr. George Lockhart again in charge it is certain that a very good show will be provided.

On January 21 the West Regional station is broadcasting a concert arranged by the Cinderford Miners' Welfare Association.

Russian music by the Midland Studio Orchestra is to precede a performance of a one-act play, *The Artist*, on January 19. The play is based on a story by Anton Tchekov.

A recital of pianoforte music by Josef Holbrooke, is a novel feature of Midland Regional programmes on January 19.

One of the explanations of the reason for so much Scottish broadcasting fare being given to Glasgow listeners, as compared with other centres in Scotland, bids fair to initiate a new controversy. The point put forward was that "in many respects, Glasgow is a much more Scottish city than Edinburgh."

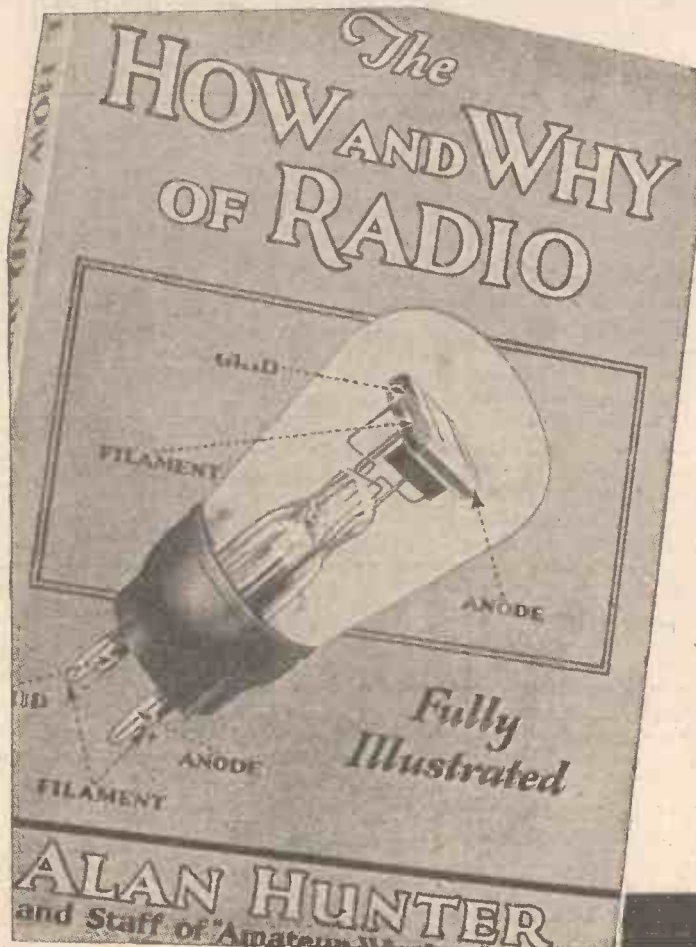

EXPRESSLY WRITTEN FOR THE BEGINNER

"The How and Why of Radio," by Alan Hunter, has been expressly written for beginners.

It provides a clear conception of the general theory and practices of wireless reception in simple, non-technical terms, and contains over ninety clearly defined illustrations. It has been mainly compiled from the series of articles in AMATEUR WIRELESS:—"The How and Why of Radio"—which proved so popular during the past twelve months.

Get this indispensable book NOW. Of all Newsagents and Booksellers, or 2/9 post free

from

"AMATEUR WIRELESS,"
58/61 Fetter Lane, London, E.C. 4



BROADCAST TELEPHONY

Broadcasting Stations classified by country and in order of wavelengths. For the purpose of better comparison, the power indicated is aerial energy.

Kilo-Metres	Station and Call Sign	Power (Kw.)	Kilo-Metres	Station and Call Sign	Power (Kw.)	Kilo-Metres	Station and Call Sign	Power (Kw.)									
GREAT BRITAIN																	
35.53	11,751 Chelmsford (G5SW)	10.0	317.3	945.4 Marseilles	0.3	LITHUANIA											
242.3	1,238 Belfast	1.2	327.5	970 Grenoble (PTT)	3.0	1,935	155 Kaunas	7.0									
261.5	1,147 London Nat.	08.0	328.9	972 Poste Parisien	1.2	NORTH AFRICA											
288.5	1,040 Newcastle	1.2	345.2	869 Strasburg (PTT)	15.0	303.4	825.3 Algiers (PTT)	13.0									
288.5	1,040 Swansea	0.10	384.4	779 Radio Toulouse	8.0	416	721 Radio Maroc (Rabat)	10.0									
288.5	1,040 Plymouth	0.16	447.1	671 Paris (PTT)	5.0	NORWAY											
288.5	1,040 Edinburgh	0.4	468	644 Lyons (PTT)	2.3	235.5	1,274 Kristiansand	0.6									
288.5	1,040 Dundee	0.16	1,445.7	207.5 Eiffel Tower	15.0	240.2	1,249.3 Stavanger	0.6									
288.5	1,040 Bourne-mouth	1.2	1,724.1	174 Radio Paris	85.0	364	824 Bergen	1.35									
288.5	1,040 Aberdeen	1.2	GERMANY						367.6	816 Frederiksstad	0.8						
301.5	995 North National	70.0	19.73	15,226 Zeesen	15.0	453.2	662 Porsgrund	0.8	493.4	608 Trondheim	1.8						
309.9	968 Cardiff	1.2	31.38	9,560 Zeesen	15.0	580	517.6 Hamar	0.8	1,091.7	274.8 Oslo	75.0						
355.8	843 London Regional	70.0	217	1,382 Königsberg	0.7	POLAND											
376.4	797 Glasgow	1.2	215.9	1,370.9 Flensburg	1.6	214.2	1,400 Warsaw (2)	1.9	234	1,283 Lodz	2.2						
398.9	752 Midland Regional	38.0	227.4	1,319 Cologne	1.7	312.8	959 Cracow	1.5	334.4	867 Poznan	1.9						
480	625 North Regional	70.0	227.4	1,319 Münster	0.6	380.7	788 Lvov	21.0	409.8	732 Katowice	16.0						
1,554.4	193 Daventry (Nat.)	35.0	227.4	1,319 Aachen	0.8	495.9	605 Wilno	21.0	1,411.8	212.5 Warsaw	158.0						
AUSTRIA									PORTUGAL								
218.7	1,375 Salzburg	0.6	232.2	1,292 Kiel	0.94	290.5	1,933 Lisbon (CTIAA)	2.0	also on 42.9 m.								
245.9	1,220 Linz	0.6	239.4	1,253 Nürnberg	2.3	ROMANIA											
285.2	1,052 Innsbruck	0.6	245.9	1,220 Cassel	0.3	394	761 Bucharest	16.0	RUSSIA								
352.1	832 Graz	9.5	253	1,184 Gleiwitz	5.6	424.3	707 Moscow-Stalin	100.0	720	410.6 Moscow (PTT)	20.0						
453.2	666 Klagenfurt	0.6	259.3	1,157 Leipzig	2.3	937.5	320 Karkov (Rv20)	25.0	907.7	310 Alma-Ata	10.0						
517	581 Vienna	20.0	269.8	1,112 Bremen	0.2	1,000	300 Leningrad	100.0	1,034.5	290 Tiflis	10.0						
also testing on 1,237 m. from 7.0 p.m. (Mon., Wed., Sat.)									1,116	268.5 Moscow Popoff	75.0	1,170	256.4 Tascherit	25.0			
BELGIUM									1,304	230 Moscow (Trades Unions)	105.0	1,481	202.5 Moscow	100.0			
206	1,456 Antwerp	0.4	283	1,060 Magdeburg	0.6	1,600	787.5 Irkutsk	15.0	1,910.8	157 Sverdlovsk	20.0						
208.3	1,440 Liège	0.15	283	1,060 Berlin (E)	0.0	SPAIN											
215.3	1,393 Chatelaineau	0.2	283	1,060 Stettin	0.0	253.3	1185 Barcelona (EAJ15)	1.0	268.9	1,115.5 Valencia	5.0						
216	1,389 Liège	0.1	318.8	941 Dresden	0.3	348.8	860 Barcelona (EAJ1)	8.0	368.1	815 Seville (EAJ5)	1.5						
216	1,389 Bruxelles	0.1	325	923 Breslau	1.7	409.8	732 Madrid España	2.0	424	707 Madrid (EAJ7)	2.0						
Conference									454.6	660 San Sebastian (EAJ8)	0.6	SWEDEN					
219.7	1,365.6 Binche	0.2	360.6	832 Mühlacker	75.0	424.3	707 Moscow-Stalin	100.0	230.6	1,301 Malmö	0.75						
210.8	1,245.8 Liège	0.1	372	806 Hamburg	1.7	720	410.6 Moscow (PTT)	20.0	257	1,167 Hörby	15.0						
244.9	1,225 Schaerbeek	0.2	389.6	770 Frankfurt	1.7	937.5	320 Karkov (Rv20)	25.0	306.8	977 Falun	0.05						
273	1,095 Radio Cointe	0.4	419	716 Berlin	1.7	1,000	300 Leningrad	100.0	321.0	932 Goteborg	15.0						
280.2	1,071 Brussels (SBR)	0.5	453.2	662 Danzig	0.6	1,034.5	290 Tiflis	10.0	435.4	689 Stockholm	75.0						
338.2	837 Brussels (No. 2)	20.0	472.4	635 Langenberg	75.0	1,116	268.5 Moscow Popoff	75.0	541.5	554 Sundsvall	15.0						
509	590 Brussels (No. 1)	20.0	532.9	563 Munich	1.7	1,170	256.4 Tascherit	25.0	770	389 Ostersond	0.7						
BULGARIA									1,239.5	242 Boden	0.75	1,348.3	222.5 Motala	40.0			
318.8	941 Sofia (Rodno Radio)	1.0	559.7	536 Kaiserslautern	1.7	SWITZERLAND											
CZECHO-SLOVAKIA									1,481	202.5 Moscow	100.0	244.1	1,229 Basle	0.65			
249.6	1,207.8 Prague (2)	5.0	559.7	536 Augsburg	0.3	246	1,220 Berne	0.5	246	1,220 Berne	0.5						
263.8	1,137 Moravska-Ostrava	11.0	569.3	530 Hanover	0.3	403	743 Sötens	25.0	459	653 Betsunwenster	75.0						
279	1,076 Bratislava	14.0	569.3	527 Freiburg	0.3	TURKEY											
293	1,022 Kosice	2.5	1,034.9	183.5 Norddeich	10.0	1,204.8	249 Istanbul	5.0	YUGOSLAVIA								
341.7	878 Brunn (Brno)	34.0	1,034.9	183.5 Zeesen	75.0	1,538	195 Ankara	7.0	307	977 Zagreb (Agram)	0.7						
488.6	614 Prague	120.0	2,525	119.3 Königswuster	1.0	430.4	697 Belgrade	3.0	574.7	523 Ljubljana	2.8						
DENMARK									2,900	103.5 hausen (press)	15.0	HUNGARY					
281.2	1,067 Copenhagen	1.0	4,000	75	HOLLAND						550	545 Budapest	23.0				
1,153	260 Kalundborg	7.5	ICELAND									1,175	255.4 Reykjavik	16.0			
ESTONIA									IRISH FREE STATE						224.4	1,337 Cork (6CK)	1.5
296.1	1,013 Tallinn	10.0	ITALY									413	725 Dublin (2RN)	1.5			
468.8	1,640 Tartu	0.5	80	3,750 Rome (SRO)	14.0	JAPAN						247.7	1,211 Trieste	15.0			
FINLAND									247.7	1,211 Trieste	15.0	273.6	1,096 Turin (Torino)	10.5			
201	1,031 Viipuri	13.2	273.6	1,096 Turin (Torino)	10.5	312.2	561 Genoa (Genova)	15.0	318.8	941 Naples	1.7						
308.1	815 Helsinki	13.2	312.2	561 Genoa (Genova)	15.0	331.5	905 Milan	8.5	368.1	815 Bolzano	1.5						
559.7	536 Tampere	1.0	318.8	941 Naples	1.7	441	680 Rome (Roma)	75.0	501.7	598 Florence (Firenze)	30.0						
1,790	167 Lahti	54.0	331.5	905 Milan	8.5	542.5	553 Palermo	3.7	LATVIA								
FRANCE									80	3,750 Rome (SRO)	14.0	525	572 Riga	13.0			
220.3	1,361 Béziers	0.5	247.7	1,211 Trieste	15.0	NETHERLANDS											
222	1,351 Fécamp	5.0	273.6	1,096 Turin (Torino)	10.5	273.6	1,096 Turin (Torino)	10.5	NEW ZEALAND								
245.9	1,220 Sunday after 11.0 p.m.	5.0	312.2	561 Genoa (Genova)	15.0	318.8	941 Naples	1.7	249.6	1,207.8 Prague (2)	5.0						
237.6	1,361.2 Bordeaux-Sud-Ouest	2.0	368.1	815 Bolzano	1.5	331.5	905 Milan	8.5	263.8	1,137 Moravska-Ostrava	11.0						
249.6	1,202 Juan-les-Pins	0.5	441	680 Rome (Roma)	75.0	441	680 Rome (Roma)	75.0	341.7	878 Brunn (Brno)	34.0						
255.1	1,176 Toulouse (PTT)	1.0	501.7	598 Florence (Firenze)	30.0	501.7	598 Florence (Firenze)	30.0	488.6	614 Prague	120.0						
265.4	1,130 Lille (PTT)	2.0	542.5	553 Palermo	3.7	542.5	553 Palermo	3.7	281.2	1,067 Copenhagen	1.0						
271.5	1,105 Rennes	1.2	PORTUGAL						290.5	1,933 Lisbon (CTIAA)	2.0						
286	1,049 Montpellier	2.0	ROMANIA						394	761 Bucharest	16.0						
287.3	1,044 Radio Lyons	30.0	RUSSIA						424.3	707 Moscow-Stalin	100.0						
294.0	1,018 Limoges (PTT)	1.0	SPAIN						720	410.6 Moscow (PTT)	20.0						
304.9	984 Bordeaux (PTT)	15.0	SWEDEN						937.5	320 Karkov (Rv20)	25.0						
312.6	960 Natan-Vitius (Paris)	0.5	SWITZERLAND						1,000	300 Leningrad	100.0						

WHEN SUBMITTING QUERIES

Please write concisely, giving essential particulars. A Fee of One Shilling (postal order), a stamped addressed envelope, and the coupon on the last page must accompany all letters. The following points should be noted.
Not more than two questions should be sent with any one letter.
The designing of apparatus or receivers cannot be undertaken.
Modifications of a straightforward nature can be made to blueprints, but we reserve to ourselves the right to determine the extent of an alteration to come within the scope of a query. Modifications

to proprietary receivers and designs published by contemporary journals cannot be undertaken.
Readers' sets and components cannot be tested at this office. Readers desiring specific information upon any problem should not ask for it to be published in a forthcoming issue, as only queries of general interest are published and these only at our discretion. Queries cannot be answered by telephone or personally.
Readers ordering blueprints and requiring technical information in addition, should address a separate letter to the Query Department and conform with the rules.

Tests with the PHOHI transmitter acquired by the A.V.R.O. broadcasting association for the transmission of their programmes through Hilversum have proved disappointing. Although the power used was in the region of 20 kilowatts, experiments demonstrated that the 208.8-

metre channel was an unsatisfactory one and that the broadcasts were subject to long periods of fading. The experience gained by the A.V.R.O. in these recent tests has intensified their decision to push forward with their scheme to erect a 60-kilowatt station as quickly as possible.

"RED DIAMOND" SWITCHES
TRADE MARK
Robust Construction. Definite "on" and "off" positions. No shaking. Perfect contacts. Large terminals for easy fitting.

RECP
RD39 2 point .. 1/3 1/6
RD49 .. dead spindle .. 1/3 1/6
RD37 3 point .. 1/6 1/9
RD47 .. dead spindle .. 1/6 1/9
RD35 4 point .. 2/- 2/3
By post

"RED DIAMOND" DETECTOR
As specified for Crystal Set for 1937

RD1 2/-
By insured Post 2/3 or 2/9 with shield.

Can be mounted on brackets or through panel. Once set always ready. Not affected by vibration. Each one is tested on broadcast before dispatch.

Of all high-class Radio Dealers or Sole Makers:
JEWEL PEN CO., LTD.
(Radio Dept. 45), 21-22, Great Sutton Street, LONDON, E.C.1

OWNERS OF BATTERY SETS CAN NOW CONVERT
NO ACCUMULATOR NO H.T. BATTERY
The new M.P.R. all mains equipment will run your present set, without any alteration, straight from your electric light supply.



Price: £6 19s. 6d.
EXTENDED PAYMENT (H.P.)
1st PAYMENT 33/6 and 8 monthly payments of 15/-
Space Occupation:—11 in. x 5 1/2 in. x 5 1/2 in. high
Full details from
MAINS POWER RADIO CO.
BROADWAY WORKS, ROMFORD

YOU CAN BUILD A £40 GRAMOPHONE WITH OUR SCALE DRAWINGS FOR 40/-

Book of instructions 3d. Catalogue of Motors, Tonearms, Soundboxes, latest internal amplifiers, Gramophones and Cabinets Free. Cash or Terms.
W. BURT, 185 High St., Deptford

GRIPSO
"SUPER PUSH-PULL" INDICATING SWITCH WITH FOOLPROOF CONTACTS
NICKEL PLATED OR BRONZE FINISHINGS
2PT. 19 3PT. 2/- G.M.B. 2/-
THE GRIPSO COY.
MAKERS' 32, VICTORIA STREET LONDON, S.W.1

TAYLEX WET H.T. BATTERIES
New Prices: Jars 1/3, Sacs 1/2, Zincs 10d; Sample doz. 18 Volts complete with bands and electrolyte 4 1 post 9d. Sample unit 6d. Illus. booklet free. Bargain list free.
AMPLIFIERS 30/- 3 VALVE ALL-STATION SET 85.
A. TAYLOR, 57, Studley Road, Stockwell, LONDON.

PREPAID ADVERTISEMENTS

Advertisements under this head are charged **THREEPENCE PER WORD**, minimum charge **THREE SHILLINGS. DEPOSIT SYSTEM**
As the Publishers cannot accept responsibility for the bona fides of advertisers in this publication, they have introduced a system of deposit which it is recommended should be adopted by readers when dealing with persons with whom they are unacquainted. It is here explained.
Intending purchasers should forward to the Publishers the amount of the purchase, less money of the article advertised. This will be acknowledged to both the Depositor and the Vendor, whose names and addresses must necessarily be given. The deposit is retained until advice is received of the completion of the purchase, or of the article having been returned to and accepted by the Vendor. In addition to the amount of the Deposit, a Fee of 6d. for sums of £1 and under, and 1s. for amounts in excess of £1, to cover postage, etc., must be remitted at the same time. In cases of persons not resident within the United Kingdom, double fees are charged.

The amount of the Deposit and Fee must be remitted by Postal Order or Registered Letter (Cheques cannot be accepted), addressed to
"AMATEUR WIRELESS" ADVERTISEMENT DEPARTMENT,
58/61 FETTER LANE, LONDON, E.C.4

BRYCE'S Renowned Mains Transformers and Chokes, from 15/- . Approved by "Amateur Wireless" and "Wireless World."—Bryce's, 54 Dawson Street, Bury, Lancs.

ELIMINATOR COMPONENTS for home constructors. Stamped addressed envelope brings Eliminator Diagrams, with prices of complete range of mains components.—Mains Power Radio, Broadway Works, Eastern Road, Romford, Essex.

OAK CABINETS. Pedestal. Send for list.—R. W. Nurse, Union Street, King's Lynn.

TRANSFORMER STAMPINGS, Instrument Wire, etc. Cheap. Lists free.—Lumen Electric Company, 9 Scarisbrick Avenue, Litherland, Seaforth, Lancs.

ELECTRICAL ENGINEERS.—Start the New Year with a T.E.C. home course in Electrical Engineering, Wiring, or Battery Charging! We guarantee satisfaction or return your fees. Can anything be fairer than this? Write for "Prospectus and Guide to Success" from W. S. Ibbotson, B.Sc., A.M.I.E.E., Technical Engineering College, 16 Speenham Road, Stockwell, London, S.W.9.

CHARGE YOUR H.T. FROM YOUR L.T. AT HOME.—Combination trickle. Charges efficiently 1 to 12 H.T. 10-volt accumulators, 10/6. Postage 6d. Diagram only, 1/6.—R. Fox, 188 Camberwell Gate, S.E.5.

INVENTOR'S POCKET-BOOK. How to patent. Invaluable aid to selling your ideas. Expert advice. Copies free.—Edwin G. Axe, A.I.M.E., 27 Chancery Lane, London.

OAK CABINETS, for Telsen V3, well made and hand polished, 7/-, C.P.; 12 by 7 in., 14 by 7 by 10 in., 7/6; 16 by 7 or 8 in., 18 by 7 by 10 in., 8/-; 21 by 7 by 10 in., 9/6, C.P. Baseboards, 6d. Rubber, feet 9d. C.W.O. Refunded unsatisfied. State nearest station. Panels supplied.—F. S. Gibson, Cabinet Maker, 99 Burnley Road, Ainsdale, Lancs. Tel. 7557.

MOVING-COIL LOUD-SPEAKERS.—New surplus Kolster-Brandes' 4 v., 22/6. Marconiphone 6v. Units, 20/—Hillier, 22 Cork Street, W.1.

FAMOUS FOR MAIL ORDERS.—Components, Valves, Moving-coil Speakers. Wholesale. Complete Receivers, 35/-. Stamp Lists.—Simmons Radio Supplies, 9 Ilfracombe Avenue, Southend-on-Sea.

ENGINEERS, are you earning less than £10 per week? If so, you cannot afford to carry on without reading "Engineering Opportunities." This 200-page book is filled with matters of vital importance to you. Among other things, it explains the methods of our unique Appointments Department, gives details of all leading Eng. Exams. (A.M.I.Mech.E., I.E.E., B.Sc., G.P.O., etc.) and outlines modern Home Study Courses in Civil, Mech., Elec., Motor, Aero, Radio, Talkie, and all other branches of Engineering. This book will alter your entire outlook and earning power during 1932. It is quite free. Write for your copy now.—British Institute of Engineering Technology, 109 Shakespeare House, 29-31 Oxford Street, London.

EBONITE PANELS, finest quality, double sided, jet black and beautifully grained both sides, mirror polished; sizes 18 x 7 and 16 x 8 3/9, 14 x 7 3/4, post paid.—Kenneth B. Caplin, 22 Station Road, Totton, Hants.

KIT OF PARTS for Britain's Super, including set of Mullard valves, £10. C.O.D.—Hodgson Radio, Marchamle-Fen, Boston, Lincs.

FRETS. Cut any size and pattern. Cabinet makers supplied at reasonable prices. Quotations Free.—W. Russell, 180 Heath End Road, Nuneaton.

BUY BRITISH.—The "Tonic" Self-generating Trickle-charger Kit enables everybody to keep their 2-volt L.T. accumulators fully charged at home. Ideal for remote places. Obtainable only from maker, 7/- each; postage 9d.—Williams, Netherend, Cradley, Birmingham.

MOVING-COIL SPEAKERS.—Various makes, from 10/- to 30/-, with input transformer. Brand new. 6 to 240 volts. A.O. or D.C., and P.M. Write Plater, 92 Umfreville Road, Harringay, N.4.

BANKRUPT BARGAINS.—List with 3-valve diagram free. Kits: 3-valve, with cabinet, 32/6; 2-valve, 24/-; Century Super, 76/-; Britain's Super, 45/5/-; Three-guinea Four, 47/6. Any kit supplied. Modern second-hand parts taken in part exchange. Speaker kits from 10/6. Telsen kits, get my prices. Transformers from 2/9. Wavemaster 0005, 2/6. Differentials, 2/-. Telsen, 1/9. Dials from 1/2. Panels, 14 by 7 in., 2/6, 18 by 7 in., 3/-. All smaller parts very keen prices. Triotron speaker units, 9/6. Zelco, 4/- . Daptacon pick-ups, with arm, 14/6. Dual coils, 4/- . Volume controls, 2/- . Eliminators A.C., 40/-; D.C., from 15/- . Three-valve sets with Tungrams, 50/- . Get my price for anything.—Butlin, 143b Preston Road Brighton.

"CHOOSING AN ELECTRIC MOTOR FOR YOUR RADIO-GRAM"

(Continued from page 40)

for some time, great care must be exercised in choosing the very best that can be afforded.

Induction motors will only run on alternating current. They are the most popular for radio-gramophone work at the present time.

They are simple in construction, robust, and cheap to buy. They cause no interference when properly designed and have no brushes to give trouble. Their speeds can be varied over a good range if required, and they are very powerful. There are two main types on the market.

The former class is the more silent. Slow-running motors are invariably large and, therefore, more expensive.

Synchronous motors are the latest type of electric gramophone drive.

They are the simplest and cheapest class. They are only suitable for alternating current, and as their speed is fixed by the frequency of supply, they have no governor and their speed is rigidly fixed at 78 r.p.m. They are not normally self starting. The turntable has to be given a spin by hand to start it.

Synchronous motors are a little more liable to pick-up interference than the induction type of motor, but if care is taken in wiring, this is not serious. The synchronous motor is much more shallow in construction than the other types and for this reason is very suitable where cabinet space is limited.

S. SHREWSBURY LANE.

AN AMATEUR SHOW

THERE are some keen amateurs in the Gillingham district! The local Medway Experimental Transmitting Society, of which Sir Robert Gower, O.B.E., is president, is holding an amateur show of radio gear on January 13, at the Gillingham Technical Institute. Listeners who can conveniently do so are advised to see the display, for many leading concerns are providing apparatus for show and demonstration.

"Amateur Wireless and Radiovision." Price Threepence. Published on Thursdays and bearing the date of Saturday immediately following. Post free to any part of the world: 3 months, 4s. 6d.; 6 months, 8s. 9d.; 12 months, 17s. 6d. Postal Orders, Post Office Orders, or Cheques should be made payable to "Bernard Jones Publications, Ltd."

General Correspondence is to be brief and written on one side of the paper only. All sketches and drawings to be on separate sheets. Contributions are always welcome, will be promptly considered, and if used will be paid for. Communications should be addressed, according to their nature, to The Editor, The Advertisement Manager, or The Publisher, "Amateur Wireless," 58-61 Fetter Lane, London, E.C.4.

BANKRUPT STOCK.—Few Amplion M.C.4 Units to be cleared at 50/-, carriage C.O.D. Guaranteed new and unopened.—123 Choumert Road, S.E.15.

KITS.—"Britain's Super," £6; "Century Super," £3/15/-; "Comet Three," £2/2/-; G.E.C. "Victor Three," £1/13/6. "Britain's Super Two" Valve Set, complete with valves, batteries, speaker, £3/12/- . Anything wireless supplied at keener prices. Send your lists of requirements for quotation.—Servwell Wireless Supplies, 74 Gough Street London, E.14.

Guaranteed!

Less than 1/2 per square inch
A 7"x18" panel costs only 4/6

Purest Ebonite.
NEVER DISCOLOURS
Magnificent mirror polish.
Black, Mahogany or Walnut finishes.
Easy to cut and Drill.
Highest insulation.
Specified continuously by leading journals.
Ask your dealer or write for list. Any panel size cut. Cash or C.O.D. by return.
British Hard Rubber Co. Ltd.
Ponders End, Middlesex.

PERMCOIL

FIX A 'PIX' IN YOUR AERIAL—

to give your set knife-edge selectivity and get those elusive foreign stations. The 'PIX' is also a volume control— from a whisper to full strength, super-hot selectivity on 3 valves. From your radio shop or send direct to:



Amateur Research Co., 14 Newgate Street, London, E.C.1

REPAIRS to Loud-speakers, Transformers, and Headphones, 4/- each; Blue Spots, 6/- . Prompt Service; twelve months' guarantee. Discount to trade.
Loud-Speaker Repair Co., 2 Shiroka Road, Batham, London.

ELECTRADIX BARGAINS

of everything
RADIO and ELECTRICAL

Send 4d. Stamp NOW for Illustrated Catalogue and Jan.-Feb. Sale List.

ELECTRADIX RADIOS,
21B, Upper Thames Street, E.C.4.
City 0191

SITUATION WANTED

Advertiser, age twenty-two, requires situation in **PUBLICITY** or **TECHNICAL** department of radio apparatus manufacturers. Four years experience gained in publicity department of leading British valve manufacturers. Knowledge of printing of technical catalogues and dealers' aids, including handling of blocks, advertisement schedules, etc. Sound technical knowledge of all radio apparatus. Experience in the operation of large power amplifiers for public address work. Excellent references obtainable. Write J. H. Watts, 7, Osborne Road, Palmers Green, London, N.13.

Wireless Sets Modernised!

Estimates Free

You will be surprised at our low charges for the repairing, rewiring and modernising of sets. Let us have your instrument and we will send an estimate without obligation. Fully qualified technical staff.

The Radio Repairs & Service Co.
56 Vicarage Lane, Ilford

FULL-SIZE BLUEPRINTS

EACH BLUEPRINT SHOWS THE POSITION OF EVERY COMPONENT AND EVERY WIRE, AND MAKES CONSTRUCTION A SIMPLE MATTER.

WHEN ORDERING, PLEASE SEND A POSTAL ORDER, NOT STAMPS, TO BLUEPRINT DEPT., "AMATEUR WIRELESS," 58/61 FETTER LANE, LONDON, E.C.4 GIVING NAME OF SET AND NUMBER OF BLUEPRINT REQUIRED.

CRYSTAL SET

6d., post free.

1931 Crystal Set AW308

ONE-VALVE SET

1s. post free.

Easy-to-build One AW304

TWO-VALVE SETS

All these 1s. each, post free.

- Hyper-selective Two (D, Pentode) AW198
- British Broadcast Two (D, Trans) AW215
- Wavelets Two (D, Trans) AW229
- No-battery A.C. Mains Two (D, Trans) AW230
- No-battery Gramo-radio 2 (D, Trans) AW238
- Arrow Two (D, Trans) AW249
- Forty-five-Shilling Two (D, Trans) AW250
- Challenge Two (D, Trans) AW261
- Twenty-Shilling Two (D, Trans) AW274
- Room-to-Room Two (D, Trans) AW298
- Big Volume 2 (D, Pen) AW309
- Two Star 2 (D, Pen) AW315
- A.B.C. 2 (D, Trans) with copy "W.M." 1s. 3d. WM160
- Brookman's Two (D, Trans) WM168
- Programme Two (D, Trans) WM201
- Cleaver Two (D, Trans) WM213
- Merlin Two (A.C. set) WM220
- Five-point Two (D, Trans) WM241
- Ever Tuned Regional Two (D, Trans) WM253
- Station Finder Two (D, Trans) WM254
- Music Lover's Two (D, Trans) WM260
- New Economy Two (D, Trans) WM265

THREE-VALVE SETS

All these 1s. each, post free.

- Brookman's By-pass Three (D, 2 Trans) AW220
- 1930 Clatton Three (SG, D, Trans) AW223
- Auro Coupler Three (D, 2LF) AW225
- Car Three (D, RC, Trans) AW244
- The "A.W." Exhibition 3 AW247
- "A.W." Challenge Kit Three (SG, D, Trans) AW256
- Push-pull D.C. Mains "Two" (D, Push-pull) AW270
- 1931 Ether Searcher (SG, D, Trans) AW271
- 1931 Ether Searcher (A.C. Model) AW276
- 1931 Ether Searcher (D.C. Model) AW284
- Mains Unit AW285
- B.B.C. Selective Three (D, RC, Trans) AW289
- Square Peak Three (SG, D, Trans) AW293
- Universal Short-wave Three (SG, D, Trans) AW301
- Olympian Three (SG, D, Trans) AW306
- 1931 Britain's Favourite Three (D, RC, Trans) AW299
- Universal Short-wave 3 (SG, D, Trans) AW301
- Olympian Three (SG, D, Trans) AW306
- Three Star 3 (SG, D, Pen) AW313
- Trinity Three (D, RC, RC.) AW321
- The Baby Three (D, RC, Trans) AW277
- Short Wave Link (D, RC, Trans) WM142

- Fanfare (D, 2 Trans) WM157
- Brookmans Three (SG, D, Trans) WM161
- Brookmans Push-pull Three (SG, D, Trans) 1/6 WM170
- Celerity Three (SG, D, Trans) WM173
- All-nations Three (D, 2 Trans) WM178
- Inceptordyne (SG, D, Pentode) WM179
- Music Marshall (D, 2 Trans) WM190
- Gramo-Radio D.C. Three (SG, D, Trans) WM196
- Five-point Three (SG, D, Trans) WM209
- Falcon Three (A.C. Set) WM217
- New Brookman's Three (SG, D, Trans) WM218
- Five-point Short-waver (D, RC, Trans) WM223
- Plug-in-coil Three (D, 2 Trans) WM232
- Regional Three (SG, D, Trans) WM236
- Gramo Radio A.C. Three (SG, D, Trans) WM237
- Band-pass Inceptordyne (SG, D, Trans) WM244
- Ether Marshal (SG, D, Trans) WM247
- Meridin Short-waver (D, RC, Trans) WM255
- Five-advantage Three (D, RC, Trans) WM257
- Everybody's Radio-gram (SG, D, Trans) WM258
- Double Band-pass Three (SG, D, Trans) WM259
- Everybody's Radiogram (with Automatic Grid Bias) WM262
- New Economy Three (SG, D, Trans) WM263

FOUR-VALVE SETS

All these 1s. 6d. each, post free.

- Horizon-Four (SG, D, 2 Trans) AW237
- The £3 3s. Four (SG, D, RC, Trans) AW303
- The £3 3s. Four (Improved Model) AW303A
- Everybody's Radio-gramophone (SG, D, RC, Trans) AW310
- Four Star 4 (SG, D, RC, Trans) AW318
- Drum Major (HF, D, RC, Trans) WM137
- Searcher's Four (SG, D, RC, Trans) WM194
- Regional Band-pass Four (SG, D, RC, Trans) WM211
- Five-point Four (SG, D, RC, Trans) WM216
- Regional A.C. Four (SG, D, RC, Trans) WM222
- Supertone Four (SG, D, Push-pull) WM227
- Ether Rover (SG, D, RC, Trans) WM266

FIVE-VALVE SETS

1s. 6d. post free.

- Britain's Super (Super-het) AW311
- A.C. Britain's Super (A.C. Super Het) AW322
- Mains Section (1 1/2) AW322A

SIX-VALVE SETS

All these 1s. 6d. each, post free.

- Century Super (Super-het) AW287
- A.C. Century Super (Super-het) AW295
- Mains Unit AW295A
- A.C. Super 60 Radio Gramophone (Super-het) WM239
- The Super 60 (Super-het) WM229
- A.C. Super 60, Table Model WM245
- Super 60 (with Wearite base) WM249
- Super 60 (with Lewcos base) WM251
- 1932 Super 60 (Super-het) WM269

SEVEN-VALVE SETS (1s. 6d. each)

- Super Senior (Super-het) WM256
- Super Senior (with Lewcos Base and Wearite Coils) WM261

PORTABLE SETS

- Merry-maker Portable (D, 2 Trans) AW228 1/-
- Portable Century Super (Super-het) AW297 1/6
- Picnic Portable (D, RC, Trans) WM148 1/-
- Pedlar Portable Two (D, Trans) WM195 1/-
- Home and Garden Three (D, RC, Trans) WM246 1/-

AMPLIFIERS

All these 1s. each, post free.

- Beginner's Amplifier (1-v.) 91 AW210
- Brookmans Separator (HF Unit) AW212
- Two-valve Amplifier AW216
- High Quality Amplifier for A.C. Mains AW275
- Add-on HF Screened-grid Unit AW296
- Universal Push-pull Amplifier AW309
- A.W. Record Player (L.F. Push-pull) AW319
- Concentrator (HF Unit) WM169
- Selecto Amplifier (HF Unit) WM210
- D.C. Fader WM242
- Quality Amplifier (DC) WM264

MISCELLANEOUS

- "Twin" Brookmans By-pass AW222 -/6
- Simplest H.T. Eliminator for D.C. Mains AW234 1/-
- Choke Output Unit AW240 1/-
- Simple Tester Unit AW246 -/6
- "A.W." Improved Linen-diaphragm Speaker AW248 1/-
- Handy L.T. and G.B. Unit for A.C. Mains AW254 1/-
- Ohmic Coupled DX Unit AW255 1/-
- Our H.T. Unit for A.C. Mains AW262 1/-
- Gramophone Tone Control AW264 1/-
- H.T. Unit and Trickle Charger for D.C. Mains AW272 1/-
- Booster Speaker AW286 -/6
- "A.W." Tone Changer AW288 -/6
- "A.W." Selectivity Unit AW290 -/6
- B.B.C. Official Selectivity Unit AW294 -/6
- A.C. Trickle Charger AW305 1/-
- Amateur's Linen Speaker AW307 1/-
- D.C. High-tension Unit AW312 1/-
- Output Unit for Pentode Sets AW316 1/-
- "A.W." Short-wave Adaptor AW317 1/-
- Converting a D.C. Unit to A.C. AW314 1/-
- James H.T. Unit for D.C. Mains WM133 1/-
- Two-ampere Low-tension Unit WM147 1/-
- A.C. Mains Amplifier WM149 1/-
- A.C. Mains Unit for All-wave Lodestone Five WM151 1/-
- H.T. Unit for A.C. Mains WM159 1/-
- Short-wave adaptor for Overseas Five WM192 1/-
- Staminator Unit for A.C. Mains WM202 1/-
- "W.M." Standard A.C. Unit WM214 1/-
- "W.M." Standard D.C. Unit WM215 1/-
- Falcon A.C. Unit WM219 1/-
- Loud-speaker Tone Control WM234 -/6
- New Linen Diaphragm Loud-speaker WM235 1/-
- Super 60 A.C. Unit WM248 1/-
- Simple Neon Oscillator WM250 1/-
- Plug-in S.W. Adaptor WM267 1/-
- Super-het S.W. Adaptor WM268 1/-

Copies of "Amateur Wireless" and of "Wireless Magazine" containing descriptions of most of these sets can be obtained at 4d. and 1s. 3d. respectively, post free. Index letters "A.W." refer to "Amateur Wireless" sets and "W.M." to "Wireless Magazine" sets.

THE KIT ACHIEVEMENT OF THE SEASON



Triple Wave THREE



FULLY PROTECTED
INCORPORATING
THE WONDERFUL
NEW TRIPLE WAVE,
SWITCH OPERATED,
COIL

PRICE
COIL ONLY 17/6

BUILT AROUND THE FAMOUS
Tall in one

MAZDA

THE
BRITISH
VALVES



This easily constructed Kit provides you with the opportunity, never offered before, of tuning in to the world's ultra-short wave stations in addition to the host of medium and long-wave broadcasts—by the simple turn of a neat panel switch.

NO COIL CHANGING

Another feature of this wonderfully efficient three-valver is that when the wave switch connects the ultra-short coils in circuit with the detector valve, it simultaneously reduces the capacity of the .0005 tuning condenser to .00015 through a small mica condenser and thereby enormously improves reception.

The efficiency of the Kit is assured by the use of the famous MAZDA VALVES, numbers P220A, L2, and HL2, which are obtainable from all Radio Dealers.

**KIT
COMPLETE
£3.5.0**

AN
AMAZINGLY SIMPLE
SET TO BUILD AND HANDLE
WONDERFUL RANGE & SELECTIVITY

Get this
FREE BOOKLET

Components are supplied as ready mounted in position and the simple wiring instructions are described and illustrated in this booklet, obtainable FREE from your dealer or address below



ARTHUR PREEN & CO., LTD.



**GOLDEN SQ.,
PICCADILLY CIRCUS
LONDON W.1.**