

**"BROOKMAN'S BY-PASS"—OUR NEW SELECTOR**

# Amateur Wireless

and  
Radiovision

Every  
Thursday **3<sup>d</sup>**

Vol. XVI. No. 399

Saturday, February 1, 1930

**FREE BLUEPRINT**

## BROOKMAN'S BY-PASS

**BLOTS OUT BROOKMANS AT WILL  
GIVES ANY NEAR-BY WAVELENGTH**



# An Entirely *NEW* Valve!

## OSRAM PX.4



A 4-volt valve giving **ENORMOUS POWER** both to A.C. Mains Sets using indirectly heated valves and for use with 4-volt accumulators.

**SUPER POWER**

# Osram Valves

**MADE IN ENGLAND**

*Sold by all Wireless Dealers*

This valve is the greatest advance yet in power amplification, possessing all the inherent qualities of the famous range of Osram Power Valves. It is the only valve in its class for loud speaker work, operating from 4 volts. Study the characteristics given here.

The Osram PX.4 will give greater undistorted power output on only 200 volts H.T. It has been specially designed for radio gramophones.

Filament Volts	...	...	...	4.0
Filament Current	...	0.6 amp.	approx.	
Amplification Factor	...	...	3.8	
Impedance	...	...	1,450 ohms.	
Anode volts	...	...	200 max.	
Anode dissipation	...	...	10 watts max.	

**PRICE 25/-**

*Advt. of The General Electric Co., Ltd., Magnet House, Kingsway, London, W.C.2.*

*Advertisers Appreciate Mention of "A.W." with Your Order*

**TUNE IN WITH THIS**



THE Watmel Double Range Tuner, which does away once and for all with coil changing, is the ideal tuner for the modern Radio Set. Shunted with two .0005 variables (one for reaction) it controls accurately and smoothly all waves on the bands between 250 and 600

metres and 1,000 and 2,000 metres. Change over is effected by a push-pull switch supplied with each tuner, and the price complete with switch and diagram of connection is

**12/6**

**AND TUNE OUT WITH THIS**



CONNECT this neat and attractive Watmel Wave Trap in series with your aerial lead, and you will be able to cut out those troublesome unwanted stations with ease and certainty. There are

six possible positions for the two plugs in the four sockets, so that you can suit your own aerial conditions precisely, simply by turning the small micro condenser knob.

A combination of the Watmel Tuner and the Watmel Wave Trap assures you of the finest, most selective tuning possible to the Modern Radio Receiver.

The Wave Trap costs only **8/6**

Specially wound coils for THE BROOKMAN'S BY-PASS **3/6**

□ We shall be glad to send you on request our Folder No. 102, showing you how to make up a very fine Loud-speaker from a Kit of parts, also Folder and Blueprint for building up a modern 3-valve Set.

**Watmel**

**Wireless Co., Ltd.**

Imperial Works, High St., Edware, Middlesex  
Telephone: Edware 0323 P. & T.

**A Vote of Confidence in the T.C.C.**

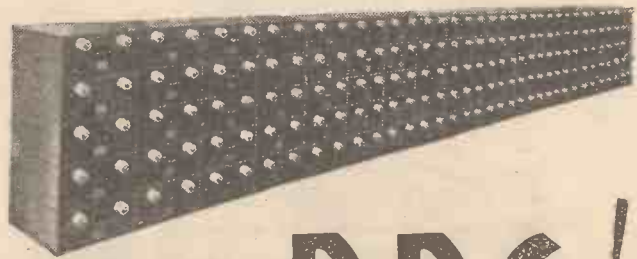

by the **B.B.C.!**

HERE is a testimony of the confidence placed, by those who know, in T.C.C. The British Broadcasting Corporation specified T.C.C. Condensers for use in their high power Brookmans Park transmitter. For such a job, only condensers having an extremely high standard of efficiency, of accuracy, of dependability could be considered and T.C.C. condensers were installed. Whether it's a bank of condensers illustrated above or just a small 2 mfd. condenser for eliminator smoothing T.C.C. are to-day the recognised standard. Consider this when you need a condenser.

The illustration above shows the bank of smoothing condensers tested to 24,000 V.D.C., for working at 12,000 V.D.C., installed at Brookman's Park.



A. Int. Telegraph Condenser Co. Ltd., Wales Farm Road, N. Acton, London, W.3.

3376

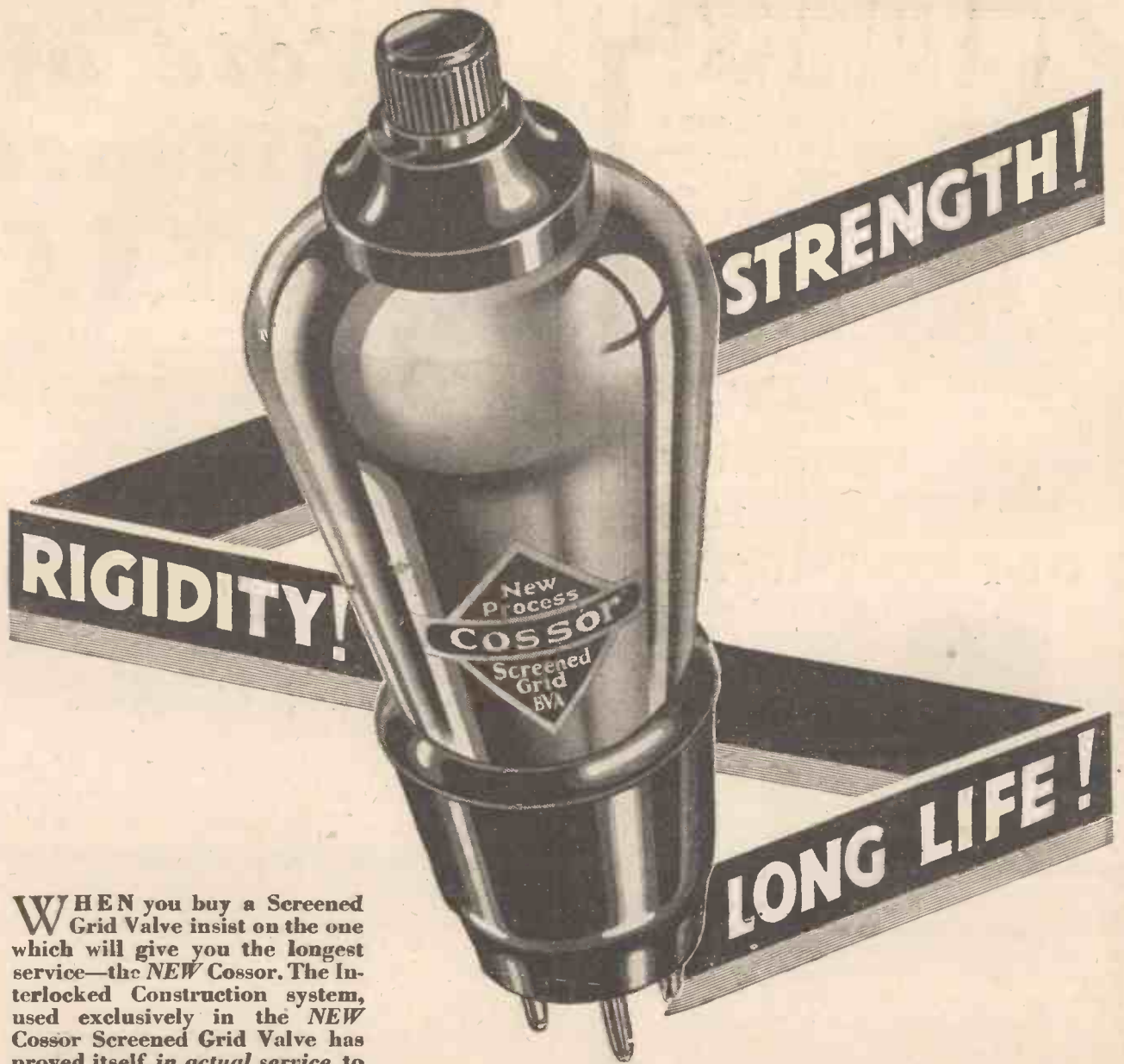

WHEN you buy a Screened Grid Valve insist on the one which will give you the longest service—the *NEW* Cossor. The Interlocked Construction system, used exclusively in the *NEW* Cossor Screened Grid Valve has proved itself, in actual service, to be the most reliable, the most robust and the most dependable method of valve construction yet devised. For power, for reliability and for long life, use the *NEW* Cossor Screened Grid Valve in your Receiver. Every Dealer sells it.

The *NEW* Cossor 220 S.G.  
(2 volts -2 amp.) Impedance  
200,000. Amplification  
Factor 200.  
Anode Volts 22/6  
120-150. Price

Cossor 4 and 6 volt  
Screened Grid Valves are  
also obtainable from all  
Wireless Dealers.

The NEW  
**COSSOR**  
Screened Grid  
Valve

A. C. Cossor Ltd., Highbury Grove, London. N5

 3343

Don't Forget to Say That You Saw it in "A.W."

# Amateur Wireless and Radiovision

The Leading Radio Weekly for the Constructor, Listener and Experimenter

— Editor: BERNARD E. JONES —

Technical Editor: J. H. REYNER, B.Sc., A.M.I.E.E. :: Research Consultant: W. JAMES :: Assistant Editor: H. CORBISHLEY

## A New SOS!—Talks, and Talks—The King's Microphone— "Incorporated" Selectivity—In a New Set—Hard on Announcers!

**A New SOS!**—A South of England store recently installed a public address equipment for the relaying of music and announcements throughout the building. The management, however, have discovered that the installation has an hitherto unsuspected use! One day a lost child was temporarily "parked" in the manager's office pending a "claim" by a harassed mother. It happened that the microphone which was installed in this office for announcing, had been left open for another announcement. The child was crying and calling for its parent. The cry was picked up by the microphone and transmitted before the switch could be closed. In another part of the store a surprised mother recognised her infant's cries coming over the loud-speaker, and after she had recovered her composure, took hasty steps to claim her offspring. This is a story told us by a Philips official who was present. Let's hope the B.B.C. doesn't start this sort of thing.

**Talks, and Talks**—There are talks, and talks. Or, to be more polite, we should say that there certainly are some talks which deserve to be given because they are records of world-famous events. For instance, one of the survivors of the Scott Polar Expeditions, Mr. William Lashly, gives a talk from Cardiff on February 14 on "The Last Journey of Captain Scott." Mr. Lashly was awarded the Albert Medal for his deeds of heroism. He is a Hampshire man, but settled in Cardiff after he returned in the *Terra Nova* from the last Scott Expedition. Talks by men who have achieved real greatness deserve the attention of listeners. They stand out from the wad of high-brow educational dissertations and dry-as-dust cookery-hint effusions.

**The King's Microphone**—On the next page we give reception reports from the many countries

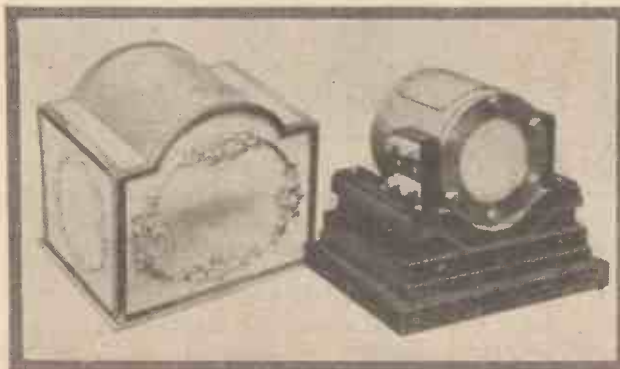

This is the "mike" reserved for the especial use of H.M. the King. He used it in the recent world-wide broadcast. It has gold-plated pole-pieces, a solid silver cover—but see the accompanying paragraph, in which it is described

which listened-in to the King's speech at the Five-Powers' Conference. An interesting feature of this broadcast was the fact that His Majesty used the special microphone reserved for his use by the Marconiphone Co. We have referred to this "mike" on several occasions when His Majesty has spoken on the wireless, or via a loud-speaker public-address system, and its description is interesting.

**Gold-plated Poles!**—The microphone is of the normal magnetic type as favoured by the Marconiphone Co., and as used on occasion by the B.B.C. It consists of a

steel pot encased in a silver sheath, the pole pieces being gold-plated. The microphone bears a silver plate on which are engraved the dates on which it has been used. The occasions are the opening of Liverpool Cathedral, opening of Wembley Exhibition, opening of the Great West Road, R.A.F. Pageant, Hendon, opening of the British Medical Association Building, opening of Kelvin Hall, Glasgow, St. George's Hall, Liverpool, and the opening of the Tyne Bridge, Newcastle-on-Tyne. The microphone is provided with a solid silver cage on which appear the Royal Arms in gold.

**"Incorporated" Selectivity**—If you are troubled with flat tuning, and find that one station interferes with another, then, of course, you will have read the article last week on the "Brookman's By-pass"—a novel gadget which will make even the worst receiver sharply tuned. This gadget forms the subject of a free gift this week of a full-size blueprint so that you can go ahead and make it up without difficulty. You can depend on it being a solution to your troubles.

**In a New Set**—But here is a suggestion. If your case is really bad, then it is reasonable to suppose that your present set is not of the most modern type. And, if this is so, then now is the time to scrap it and to incorporate in the new one a useful selectivity device. This is just what the AMATEUR WIRELESS Technical Staff has been engaged on, and next week we are publishing full constructional particulars of the "Brookman's By-pass Three"—a useful three-valve receiver incorporating the By-pass described this week. Worth while waiting? Certainly! Make up the unit this week and try it out.

**Hard on Announcers!**—The call of the new 16-k.w. Reykjavik (Iceland) transmitter on 1,200 metres, which is to be officially opened in June next, will be "Utvar-sstoed Islands."

### PRINCIPAL CONTENTS

	PAGE
Current Topics .. .. .	163
The King's Broadcast .. .. .	164
The "Best-by-Ballot 3" Proves its Worth .. .. .	165
What's Wrong with the Short Waves? .. .. .	167
For the Newcomer .. .. .	168
On Your Wavelength .. .. .	173
The Ediswan Battery-operated Receiver .. .. .	175
Transformer Building at Home .. .. .	176
Wireless to Locate Valuable Minerals .. .. .	177
"A.W." Tests of Apparatus .. .. .	178
Without Fear or Favour .. .. .	179
The "Brookman's By-pass" .. .. .	180
My Wireless Den .. .. .	184
Radiograms .. .. .	186
Our Information Bureau .. .. .	188

**M**ILLIONS of listeners in this country alone, who were able to tune in on Tuesday morning of last week to the Naval Conference were able to hear the voice of H.M. the King. It was an historic occasion, for relays and rebroadcasts over the whole world resulted in His Majesty having the largest audience in the whole history of the world!

It was a triumph for radio. Microphones and loudspeakers adorned the Royal Gallery of the House of Lords, so that all present, including four hundred journalists, could hear without difficulty. Special lighting, as used in cinema studios, blazed in the time-honoured chamber, and a London pea-soup fog formed a typical background for the world-wide broadcast! A gramophone record was made by H.M.V. of the King's speech and this was broadcast in the evening for the benefit of those who could not listen-in at 11 a.m.

In last week's *AMATEUR WIRELESS* we gave details of the way in which the

# The KING'S BROADCAST



speeches of the King and of the leading delegates were sent by radio and land-line to each country and then rebroadcast.

The two chief means of communication were the Post Office station Rugby and the Marconi short-wave station 5SW at Chelmsford. 5SW works on 25.53 metres and has a power of 15 kilowatts in the aerial. Rugby, of course, is on the "super" long waves. The reception of each makes interesting comparison.

The N.B.C. chain of broadcasting stations in the United States rebroadcast 5SW, as also did Australia, New Zealand, Japan, and Finland. The Columbia chain rebroadcast Rugby, while Canada chiefly used her own beam system.

## Relay Successes

France, Germany, Norway, Denmark, Sweden, Hungary, Austria, and Czecho-Slovakia were connected by land-line with Savoy Hill, and the ordinary B.B.C. transmissions were picked up and rebroadcast again by stations in Holland and Belgium.

*AMATEUR WIRELESS* has received authentic reports of reception, which are here given in detail. The land-line relays were entirely successful, for, of course, no fading was experienced, and there was no breakdown. France, Germany, Switzerland, and Italy were all able to hear the speeches nearly as clearly as listeners in the British Isles.

The Canadian relay was probably the most successful radio link. All the C.N.R. stations linked up, and the whole relay

from the House of Lords was heard without any severe fading. Some of the stations at the Pacific Coast end of the gigantic Canadian National Railway's chain had to start at three o'clock in the morning!

In New York it was between 5 a.m. and 6 a.m. when the King spoke, and, except for the beginning of the relay, the reception was quite good. A seven-valve set was installed in Washington for President Hoover.

Atmospherics were rather bad in some quarters, and spoiled the first part of the relay for Australia and South Africa. Reception was very poor in Tokyo. New Zealand heard the whole of the speeches clearly, and the rebroadcasts were good.

In India it was about 5 p.m., and with



An impression of the 5SW aerial. Chelmsford was picked up by five countries



Fixing the microphones in the Royal Gallery. The whole room was fitted with separate microphones for broadcasting, public-address, and gramophone recording of the King's speech

the setting sun the atmospherics were severe. As darkness came on, however, the speeches of some of the delegates were heard well.

At the *AMATEUR WIRELESS* Laboratory in Fetter Lane, London, an interesting comparison was made between the reception from 5SW (which is heard only faintly in the heart of London) and some of the American stations. With a new three-valve short-waver, having a detector valve with two low-frequency transformer-coupled stages it was possible to receive three Americans in the daytime on a short aerial, sometimes at loud-speaker strength.

KENNETH ULLYETT.

# The BEST-by-BALLOT 3<sup>rd</sup>

## Proves Its Worth

*This Set, was based upon readers' votes and was the subject of a Free Blueprint given with last week's issue. Here are some practical hints on its operation*

READERS who went ahead with the constructional operations of the "Best-by-BalLOT 3" described in last week's issue will be anxious to make certain of the operating instructions before attempting to get results with the receiver. Full operating details are here given.

There may be some readers, however, who have not yet been able to complete the construction, and there are one or two points which must be explained. In addition, there may be a few readers who did not manage to get their copy of last week's issue (with which was given a free full-size blueprint of the set—there was a record demand), and they will perhaps welcome a little explanation as to why this little three-valver is termed the "Best-by-BalLOT 3."

### The Twelve Best Features

Present constructors must therefore pardon the repetition when we explain that this set is made up according to the specification which was judged to be the best in a simple prize competition held in AMATEUR WIRELESS some weeks ago. The result of this ballot gave in tabular form the twelve essential features of a good set, and the specification is therefore in reality just what readers themselves think a receiver should be like for 1930. The title "Best-by-BalLOT" is therefore justified.

Preliminary details were given in "A.W." No. 397. In last week's issue, that is No. 398, we gave constructional features and a

bumper free gift—a full-size blueprint of the set just like those which are obtainable for every AMATEUR WIRELESS receiver through the "A.W." blueprint department, and the normal price of which would be 1s.

The constructional particulars given last week are sufficient to enable any handy man who can read a blueprint to make up this set in professional style. Emphasis must be made, however, on the necessity for wiring up neatly and correctly. Although some readers have their own pet theories as to whether or not the rigid wire system of connections is good, our advice in a receiver of this description is to wire up exactly according to the blueprint, using rigid insulated wire. Make all the corners neat and see that the spacing between each lead and the next is ample and is as nearly as possible in conformity with the photographs, which give a very good idea of the whole layout.

For the benefit of those who did not wish to start constructional operations until they had before them all the articles relating to this receiver, we publish again the list of components required.

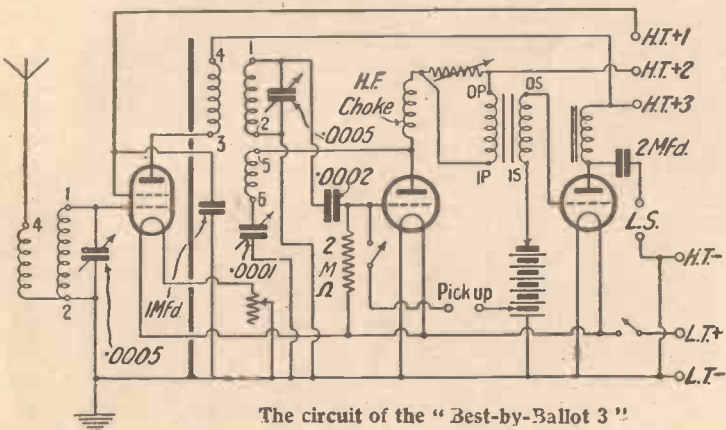

The circuit of the "Best-by-BalLOT 3"

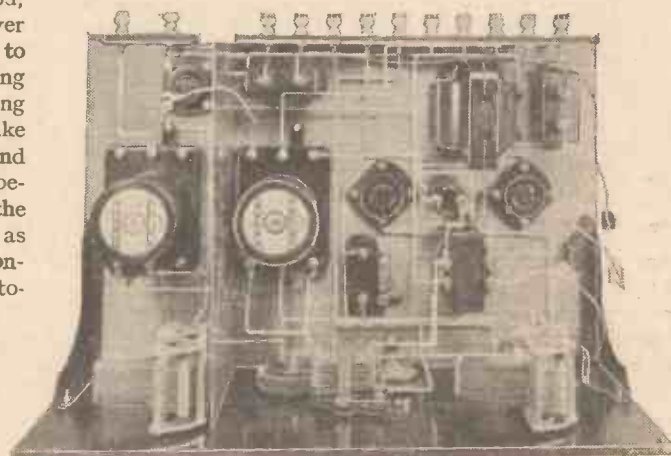

Here is a plan view of the "Best-by-BalLOT 3"

using the blueprint as a guide. If you check each wire in turn starting at wire No. 1 (that is the lead from the aerial terminal to terminal 4 of the QAT coil) you will ensure that no wire is left out. Then examine the receiver in order to make sure that the controls work properly, that the condensers have not been put out of adjustment so that the vanes touch, that the coil switches work properly, that the two push-pull switches on the panel make good contact, that all the terminals are tight, that there is no loose flex or wire ends, and so on.

The next step is to plug in the valves, and connect up the H.T., L.T., and G.B. The grid-bias battery is supported on the left-hand side of the set looking from the back. The high-tension battery and the accumulator are, of course, external to the set.

### Suitable Valves

Three valves will, of course, be required, and these can be of the 2-, 4-, or 6-volt type. If you are buying new valves then probably you will be wise to choose two-volters, for under normal conditions there is no great advantage to be gained in using a two- or three-cell accumulator (that is 4 or 6 volts), in place of a one-cell ob. Local charging facilities and the possibility of the present ownership of one or two valves likely to be suitable, or an

When you have made your choice, from the first mentioned components, or from the alternatives, you will find that our claim of low initial cost for the "Best-by-BalLOT 3" is completely justified. Let us now assume that all the wiring is done and that you have checked it over carefully

accumulator, will largely determine your choice from the 2-, 4-, or 6-volt series.

So far as types are concerned, and actual characteristics, you must adhere rigidly to valves of the following recommended types. In each case is given a selection of valves of

#### COMPONENTS REQUIRED

Ebonite panel, 16 in. by 8 in. (Lissen, Becol, Trollitax, Trelborg).  
 One ebonite strip, 3 in. by 2 in.  
 One terminal strip (Junit).  
 Baseboard, 16 in. by 10 in. (Camco, Pickett, Raymond).  
 Panel brackets (Ready-Radio, Bulgin, Lissen, Keystone).  
 Two .0005-mfd. variable condensers (Lotus, Lissen, J.B., Dubilier, Ormond, Igranic, Burton, Polar, Formo).  
 .0001-mfd. reaction condenser (Lissen, Dubilier, Ormond, Igranic).  
 15-ohm rheostat (Lissen, Varley, Sovereign, Ormond).  
 Volume control (Clarostat, Volustat, Regenstat).  
 Two push-pull on-off switches (Lissen, Junit, Bulgin, Keystone).  
 Two slow-motion dials (Brownie, Lissen, Igranic, Formo, Lotus).  
 Two dual-range coils, types Q.A.T. and Q.S.G. (Lewcos, Ready-Radio, Wearite).  
 Three valve holders (Benjamin, W.B., Lissen, Lotus, Formo).  
 .0002-mfd. fixed condenser with series clip (Dubilier, T.C.C., Lissen, Graham-Farish, Ormond).  
 1-mfd. and 2-mfd. fixed condensers (T.C.C., Dubilier, Lissen).  
 2-megohm grid-leak (Dubilier, Ediswan, Lissen, Graham-Farish).  
 H.F. choke (Peto-Scott, Lissen, Ready-Radio, Bulgin, Lewcos, Tunewell, Sovereign, Watmel).  
 J-type L.F. transformer, ratio 6 to 1 (Igranic, Lissen, Lewcos, Varley, Lotus, Burton).  
 Output choke (Lissen, Varley, Bulgin, Formo, Wearite).  
 Three wander-plugs, marked G.B.+1, G.B.—1, G.B.—2 (Belling-Lee, Eellex, Clix).  
 Twelve terminals, marked: Aerial, Earth, H.T.+1, Pick-up (2), L.T.—, L.T.+1, H.T.—, H.T.+2, H.T.+3, L.S.+1, L.S.— (Belling-Lee, Eellex, Clix, Burton, Raymond).  
 Partition screen, 10 in. by 6 in. (Ready-Radio, Parax).  
 Connecting wire and thin flex (Lewcos).

prominent manufacturers. If you do not obtain a valve of the mentioned makes, however, or you already have a valve which does not appear in the lists, then make sure before you use it that its characteristics conform to those here given. The first valve is a screen-grid valve and the following are recommended makes and types:

(Two-volters): Cossor 220SG, Dario SG, Marconi S215, Osram S215, Six-Sixty 215SG, Mullard PM12, Mazda 215SG, Lissen SG215. (Four-volters): Dario SG, Mullard PM14, Six-Sixty 4075SG, Cossor 410SG, Marconi S410, Osram S410. (Six-volters): Six-Sixty SS6075SG, Cossor 610 SG, Mullard PM16, Marconi S610, Osram S610.

#### Detector Valves

The detector valve should be selected from the following makes and types: (Two-volters): Cossor 210HF, Dario Univ., Marconi HL210, Osram HL210, Six-Sixty 210HF, Mullard PM1HF, Mazda HL210, Lissen HL210. (Four-volters): Mullard PM3, Six-Sixty 4075HF, Osram L410, Marconi L410, Dario Univ., Cossor 410HF. (Six-volters): Cossor 610HF, Marconi HL610, Osram HL610, Six-Sixty D610, Mullard PM5X, Mazda HL607.

The following valves are suitable in the power stage: (Two-volters): Cossor 220P, Dario SP, Marconi P215, Osram P215, Six-Sixty 220P, Mullard PM252, Mazda P220, Lissen P220; (Four-volters): Cossor 410P, Dario SP, Marconi P410, Osram P410, Six-Sixty 410P, Mullard PM4. (Six-volters): Cossor 610P, Marconi P610, Osram P610, Six-Sixty 610P, Mullard PM6.

#### The H.T. Supply

The following high-tension dry batteries (double-capacity type) are recommended: Selfridge "Key," Lissen, Ever-Ready, Siemens, G.E.C. Magnet, Dubilier, Hellesen, Nesper, Pertrix, Carlton Pifco, Columbia, Ecco, Ripaults, etc.

The H.T. consumption of the set is modest, but when choosing a high-tension battery you should use a medium-capacity type, if not a super-capacity type. A small-cell popular type battery definitely will not do. It is cheaper in the long run to have as large a capacity battery as the pocket will permit. The maximum voltage should be 120.

The same remarks apply to a high-tension eliminator, if one is to be used, and an eliminator giving a small current output will not be suitable; the set may howl continually.

The circuit diagram of the receiver is reproduced herewith and this will show you how the high-tension connections should be made. The terminal H.T.+3 should have the maximum voltage applied to it—120 volts or more. The terminal H.T.+2 should be connected to about the 80-100 volt tapping on the high-tension battery or eliminator. The H.T.1 terminal on the set should have a fairly critical voltage applied to it, usually between 75 and 90 volts.

#### First Tests

For a preliminary test use the set in the "radio" position—that is with the L.T. switch pulled out (switching the set on) and with the grammo-radio switch pushed in. The coil switches should be both pushed either in or out. Adjust the battery values until the set goes nicely in and out of oscillation and turn the tuning condensers approximately in step and tune in some of the main stations such as 5GB, 5XX and the local station. A little experimenting

will soon enable one to become accustomed to the controls. Use the H.F. valve filament rheostat as the volume control when working on radio.

#### Gramo-Radio

For gramophone reproduction connect the pick-up to the pick-up terminals at the back of the set, and pull out the "gramophone" switch on the panel. The H.F. valve should be switched off, of course, by means of the rheostat, and the grid bias should be adjusted until the reproduction is pure. Usually only 1½ volts will be needed

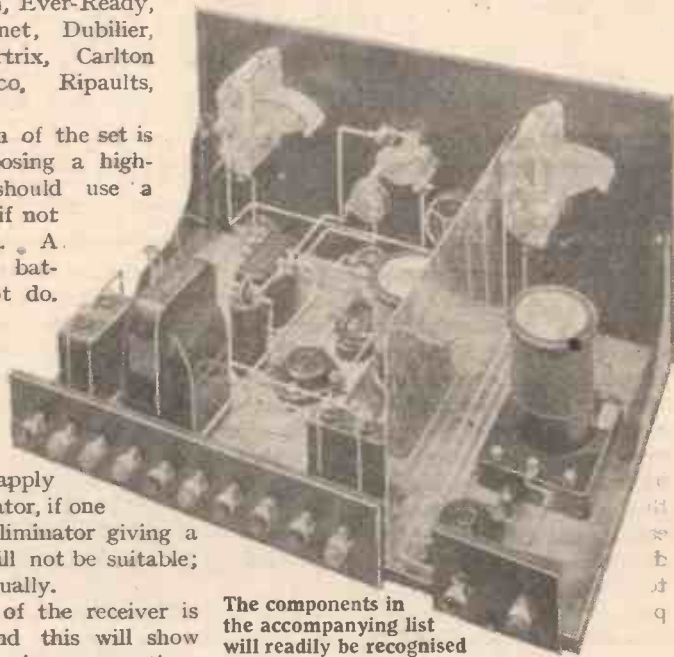

The components in the accompanying list will readily be recognised in this picture

on the flex lead attached to one pick-up terminal.

It should be noted that the "Best-by-Ballot 3" is being shown in the Somerset Street windows of Messrs. Selfridge & Co., Ltd, wherein each week a current AMATEUR WIRELESS receiver is displayed. All London readers should take advantage of the opportunity to see the receiver which is the result of their own votes.

#### ARTIFICIAL PIEZO CRYSTALS

ONE of the difficulties of using a piezo crystal to control the frequency of an oscillation generator is that of cutting a crystal of the correct dimensions for the required wavelength. A method has now been discovered of preparing artificial crystals of any required size.

Quartz, rochelle salt, or other suitable "active" crystals are first crushed or ground into small particles, which are thoroughly mixed with shellac, resin, or similar fluid insulating material. The prepared mixture is then slowly dried between the poles of a powerful electromagnet, the field of which gradually "sets" or swings each crystalline particle into the correct orientation. Corresponding to that found in the native piezo-electric substance.

B. M.

A SET THAT WILL END YOUR  
 "SWAMPING" TROUBLES AND  
 GIVE YOU REAL SELECTIVITY  
 "THE BROOKMAN'S BY-PASS 3"  
 FULL DETAILS NEXT WEEK  
 ORDER YOUR COPY NOW



# What's Wrong With the Short Waves?



Poor reception on the short waves has been very prevalent of late and in this article R. W. Hallows replies to a question that is puzzling all short-wave enthusiasts

“WHAT’S wrong with the short waves? is a question that ether-searchers all over the country have been asking themselves and one another for some little time now. I know of not a few cases where people have found their short-wave sets so completely dead that they have come to the conclusion that something must be wrong with them. The valves, batteries, condensers, and coils have all been tested out in turn and found far from wanting.

Baffled short-wavers have gone carefully over every inch of the wiring, have remade every soldered joint, have tightened down every nut to the stripping point. They have pulled down their aerials and washed the insulators. They have cleaned up earthing switches until they shone with dazzling brilliance. They have delved down towards the Antipodes to give their earth plates a better grip of the ground.

Many have torn to pieces perfectly good sets and remade them. Others have made their living rooms into temporary wire entanglements what time they unmade and remade coils and chokes. Perfectly good fixed condensers have been cast into the

dustbin, that new ones might take their place. Valve holders have fallen under suspicion. Rheostats and potentiometers have been replaced.

### Impossible to Get

And the result of all this frenzied labour is that there are still no short-wave stations. I am writing this article to save any who have not yet embarked upon the work of destruction and reconstruction from shedding their components like leaves in autumn.

I want to set their doubts at rest by assuring them that there is nothing wrong with their sets or with their aerials, or with their earths or with their batteries, or with their valves or with their ears.

The plain and simple, but painful fact is that the short waves have gone temporarily on strike.

### Now and Then

A couple of years ago short-wave reception was almost too easy. With the simplest of sets, consisting of nothing more than a detector valve plus a good note-magnifying stage, one could be sure of hearing on almost any night of the week Java and America and Canada and Australia. And these far countries were heard not as mere small voices and not through a welter of atmospherics, but as loud signals with every word as plain as plain.

I remember one evening sitting down to pick up 2XAF in order to hear his news bulletin, which is sent out at eleven o'clock by our time. It was there, right enough, though by no means so strong as usual. However, with two note-magnifying stages and the use of rather more reaction than is customary (though the set was still some distance from oscillation), I managed to get him on to the loud-speaker in such a way that he was quite comfortably audible in any part of the room. This was not too bad, but I could not understand how it was that he was not showing his customary signal strength. A little later the mystery was solved; happening to glance at the back of the set, I found that I had forgotten to connect up the aerial and earth leads!

running commentaries upon American football matches could be received with absolute certainty at fine loud-speaker volume. Australia was always there on Sunday evenings, and when Kenya started a broadcasting station we had never any doubts about being able to pick up its transmissions.

The two Radio Malabar stations in the Dutch colony of Java were to be found on any afternoon when they were working. Their strength was astonishing and fading was the exception rather than the rule. Other stations heard with perfect regularity were the various relays of KDKA, as well as WLW and quite a host of others.

This pleasant state of affairs continued for some while, but then a slow decline in all-round signal strength began to make itself felt. There were good evenings when stations had all their punch, but these became rarer and rarer as time went on. One noticed, too, that there was a good deal more fading of a rather curious type than there had been.

(Continued at foot of next page)



Capacity



Fixed Resistance

2XAD's Saturday evening relays of

## For the Newcomer to Wireless: CONDENSERS

I DON'T quite understand how a fixed condenser, such as is used in the wireless set, blocks direct current, but allows alternating to pass through it.

Well, the reason why it blocks direct current is not difficult to see, since the circuit is actually broken by the dielectric of insulating material between the plates.

Yes, I follow that but. I can't see how alternating current gets through the dielectric.

Actually it doesn't, but since the net result is much the same as if it did it is convenient to regard it as doing so.

Do please explain.

Let's take the grid condenser as an example. One set of its plates is connected to the "top" of the tuning coil and the other to the grid of the following valve. Now let us suppose that a positive half-cycle comes along. What is the result?

Well, I suppose that the first set of plates becomes positively charged?

Exactly, and, as you know, this means that there is upon them an excess of positive ions.

These attract electrons, don't they?

Yes, and repel other positive ions.

Therefore on the other set of plates we now obtain a crowd of electrons—detachable electrons from atoms in the connecting lead and the grid itself—so that these plates are negatively charged.

Let's see if I have got it clear. We now have on the plates connected to the top of the coil an army of positive ions and on those connected to the grid an army of electrons, isn't that so?

Exactly. The next instant a negative half-cycle arrives with the result that the position is exactly reversed. There is a rush of electrons to the first set of plates, and owing to their repulsion this produces a rush of electrons away from the second set. Now imagine what takes place when positive and negative half-cycles succeed one another on the first set of plates.

I suppose that there are corresponding electron streams from the grid and its lead to and from the second lot of plates?

In other words, though current does not actually pass through the dielectric in the condenser, the arrival of positive and negative half-cycles on the first set of plates produces exactly corresponding pulses of current in the con-

ductors connected to the second set. Therefore the net result in the grid circuit is just the same as if oscillating current passed through the condenser.

Can you give me a water analogy to fix it in my head?

Yes, I think so. Supposing that we had a length of tubing with a well-fitting rubber diaphragm in the middle of it, no water could pass right through the tube—could it?—for the membrane would prevent it.

I follow that.

We fill one end of the pipe with water and then insert a piston, just like that of a syringe. Then we treat the other half of the pipe in the same way. Now what happens supposing that we push in the first piston?

Why, the second will be driven outwards, because the water will be forced up, and the first against the rubber diaphragm, which will become strained and will displace water in the second part of the pipe.

Just so, and if we pull out the first piston the second will be drawn in. Thus, any movement of the first is reproduced by the second, though no water actually passes through the diaphragm.

### "WHAT'S WRONG WITH THE SHORT WAVES?"

(Continued from preceding page)

#### Two Kinds of Fading

On the short waves you get two kinds of fading. There is, first of all, the slow periodic type, such as you can notice on the ordinary broadcast band. A station seems to work up to its best strength gradually until it becomes terrific, then it gradually falls away until it is almost inaudible. In a minute or two it returns to huge strength.

The other type of fading, which is peculiar to the short waves, occurs with very great rapidity. In tests made some time ago it was found that a 20-metre station might fade many times in a single second. This kind of fading, as we most commonly notice it, occurs about once a second and gives a tremolo effect to speech and music. Often, too, it is accompanied by a sound which rather resembles that made by waves washing upon a shingle beach. At the present time quick fading is terribly bad, and nearly every short-wave transmission is affected.

And just what is causing this trouble on the belt below about 60 metres? There is, I think, only one explanation that can be given. Sun spots have been particularly active of late, and though the connection between their appearance and the occurrence of poor conditions upon the short waves is not yet properly understood,

there seems to be no doubt that they do have a very big effect.

#### Have We Reached the Limit?

The worst short-wave conditions ever known, began to be felt about a month before the end of the old year. They are still with us, though there are signs of an improvement. This period coincided with tremendous sun-spot activity. During

December and January, in fact, some of the spots were so big that they were plainly visible with the naked eye through a piece of smoked glass.

When sun spots are about, electro-magnetic disturbances occur in our atmosphere and the Heaviside layer does not seem to be able to behave as it should. Short waves are able to cover the immense distances that they do only if the atmosphere is in such a condition that they lose comparatively little of their energy as they are reflected back to earth.

If sun spots are affecting us, there are also "bright spots" to console us. On one or two recent nights, short-wave transmissions have shown something like a return to their wonted strength, and I am quite sure that it will not be long before we are once again able to hear the distant places of the world just when we want to do so. Another consolation is that sun-spots go in regular cycles of rather more than eleven years. We should notice, therefore, a very big improvement during the next few months, and it should be at least eleven years before we come back to anything like poor conditions. By that time such big advances will have been made in both reception and transmission that we shall not need to worry about sun spots.

Don't lose faith in your short-wave set. It will not be long before it is providing you with splendid entertainment, just as it used to do.



ROBERTS

An impression of Miss Olive Groves

# 3 HOURS — 300 MILES!

10,000 FEET UP! Giant Air Liner roars through clouds. Airport wirelesses warning—"Fog over French Coast." 'Plane in constant touch — receiving orders, reporting weather conditions—*through Marconi Valves*. All Imperial Airways machines are fitted with Marconi Valves. So is Croydon Control Tower. All British Broadcasting Stations . . . all Trinity House lightships . . . all Trinity House beacon stations . . . most British passenger ships . . . use Marconi Valves. For their reliability. For their long life. For their wide range.

● *In cases like these, when unfailing efficiency is essential, men insist on Marconi Valves*



## FIT

# MARCONI VALVES

## TO YOUR RADIO SET



Give you clearer tone, greater volume, longer range. Cost not a penny more. Fit any set.

*The first and greatest name in wireless*

MARCONIPHONE COMPANY LIMITED, 210-212 Tottenham Court Road, London, W.1

*Please Mention "A.W." When Corresponding with Advertisers*

## FIFTEEN OUTSTANDING FEATURES

\* \* \*

**A NEW ERA IN BROADCASTING.** By Capt. H. J. Round, M.I.E.E.

**WHAT IS HAPPENING IN TELEVISION?** We investigate the position for the Amateur.

**THE TRANSPORTABLE FOUR.** A New and Unconventional Design. By J. H. Reyner, B.Sc., A.M.I.E.E.

**WHAT BROADCAST STARS ARE REALLY LIKE.** By An Ex-announcer.

**LEAKY - GRID OR ANODE-BEND DETECTOR?** By W. James.

**THE INCEPTORDYNE.** An Outstanding Three-Valver: Full-size Lay-out and Wiring Diagrams in the Issue.

**WE HELP YOU TO CHOOSE THAT NEW SET!** Special Reports on Commercial Receivers.

**THE TRIMMER.** Simple Selectivity Unit for Any Set.

**WHY NOT BROADCAST TALKIES?** Asks Kenneth Ullyett.

**THE PROGRAMME TWO.** A Selective Loud-speaker Set: Easy to Operate.

**THE BROOKMAN'S FOUR BEATS THE BAND!** By W. James.

**USING CONSTANT-FREQUENCY RECORDS.** By J. H. Reyner, B.Sc., A.M.I.E.E.

**NEW RECORDS CRITICISED AND LISTED.** Over 250 Records Arranged in Classified Groups.

**THE ALL-NATIONS THREE.** Special Short-Wave Design for Loud-speaker Reception.

**REFERENCE SHEETS.** Compiled by J. H. Reyner, B.Sc., A.M.I.E.E.

# Before you buy

## that new set . . .

read the unbiased and authoritative reports that appear every month in "Wireless Magazine" and take advantage of the free advice Service!



The "W.M." gives quite unbiased and disinterested opinions on all types of commercial receiver.

Every prospective buyer of a radio set is invited to ask the "Wireless Magazine" for impartial advice. See the February issue for details of this valuable offer.

### FOUR SPECIAL "WIRELESS MAGAZINE" SERVICES

- 1.—Full-size blue prints of all sets constructionally described are available for half price.
- 2.—Advice on the choice of a commercial set is given free of charge.
- 3.—Representative literature issued by the trade generally is available with a minimum of trouble by using the "In Tune with the Trade" feature.
- 4.—Questions on any radio problem are answered by post.

## Wireless Magazine

The Best Shillingsworth in Radio

Is Now On Sale at All Bookstalls and Newsagents.

Get Your Copy To-Day!

Editor:

BERNARD E. JONES

Technical Editor:

J. H. REYNFR,  
B.Sc. (Hons), A.M.I.E.E.

Research Consultant:

W. JAMES

Assistant Editor:

D. SISSON RELPH



## FOR ELIMINATOR CIRCUITS

You cannot afford to use any but the best Condenser in an eliminator circuit.

### HELSEBY CONDENSERS

are made and guaranteed by a firm with 30 years' experience in condenser making, from small telephone and radio condensers to Power Condensers weighing upwards of 2 tons.

Guaranteed working voltages :-

Type M	-	-	150 volts D.C.
Type 2A	-	-	350 volts D.C.
Type 3A	-	-	450 volts D.C.
Type 4A	-	-	600 volts D.C.

All Helsby Condensers are vacuum dried and impregnated with a special non-hygroscopic material which renders them moisture proof.

*If unobtainable from your dealer write to us giving his name and address.*



**BRITISH INSULATED CABLES LTD**

PRESCOT - LANCs.

Makers of PRESCOT and HELSEBY cables

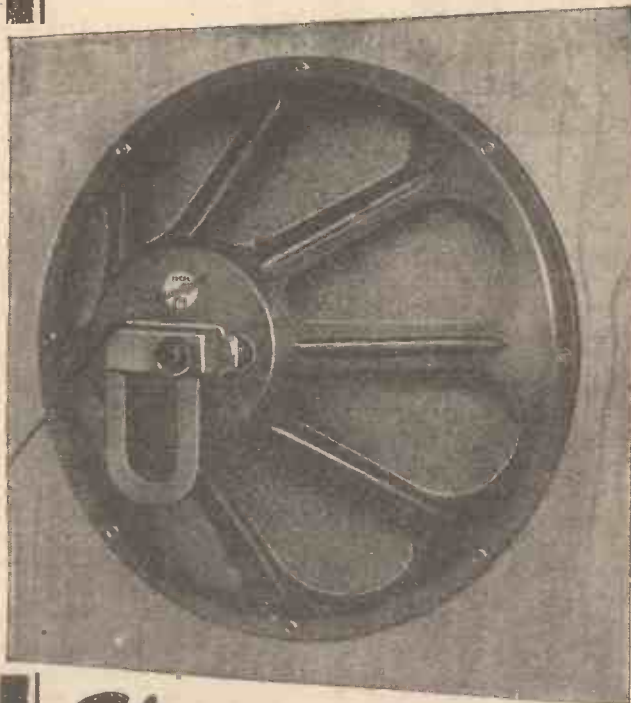

## The Summing up!



*Blue Spot Chassis are sold in two sizes, the "Major" with 13" cone, as illustrated, at 15/- and the "Minor" with 9 1/2" cone at 12/6.*

"After all is said and done, it is the Blue Spot 66K you want to buy, because really it is the best unit on the market.

And you'll get better results than ever with the Blue Spot Chassis because it has been designed to fit the 66K Unit so that it can work under the best conditions possible.

The Major or the Minor, whichever you choose, can be bolted to the unit in a few moments and it is hard to tell that it is not a moving-coil speaker playing to you. . . ."

(So says the constructor who has experimented.)

# BLUE SPOT CHASSIS

**F. A. HUGHES & CO., LIMITED**

204-6 Great Portland Street, London, W.1

Phone: Museum 8630 (4 lines)

Distributors for Northern England, Scotland and North Wales: H. C. RAWSON (SHEFFIELD & LONDON) LTD., 100 London Road, Sheffield (Phone: Sheffield 26006); 22 St. Mary's Parsonage, Manchester (Phone: Manchester City 3329).

Don't Forget to Say That You Saw it in "A.W."

# P.R. VALVES

# ABSOLUTELY ASTOUNDING

The new Golden Series of P.R. Valves give the most astounding results. The amplification is simply enormous and the selectivity abnormal. This is due entirely to the new filament coating, which is applied with scientific exactitude. It does not matter how much you pay for a valve, you will not get better than a P.R. Golden Series at 4/6. Send for one NOW. You are protected by a "straight" Guarantee that fully covers any possible failure.

**BRITISH MADE**

LIST OF P.R. SUPER GOLDEN SERIES.						
Type	Fil. volts.	Amp.	Imp. ohms.	Amp. fac.		
<b>4/6</b> EACH Post 4d.	GPR 2	2	.095	24,000	13.5	H.F. Det.
	GPR 3	2	.095	12,000	8	L.F.
	GPR 4	2	.095	40,000	32	R.C.
	GPR 9	3.5-4	.09	22,000	14.5	H.F. Det.
<b>POWER 7/6</b> EACH Post 4d.	GPR 10	3.5-4	.09	10,000	9	L.F.
	GPR 11	3.5-4	.09	44,000	41	R.C.
	GPR 17	5-6	.14	20,000	17.5	H.F. Det.
	GPR 18	5-6	.14	11,000	9.5	L.F.
<b>SUPER POWER 12/6</b> EACH Post 4d.	GPR 20	2	.15	6,000	7	Power
	GPR 40	4	.15	6,000	7	"
	GPR 60	6	.15	6,000	7	"
<b>SCREENED GRID 15/-</b> EACH Post 4d.	GPR 120	2	.2	3,500	4.5	Super Power
	GPR 140	4	.2	3,500	4.5	"
SG 25	2	.2	220,000	150	S.G.	

## PERFECT RESULTS OR MONEY BACK

All postal breakages replaced free. Each valve has attached to it a written guarantee covering 7 months. In the event of the valve losing emission or becoming inefficient in any way during this term, a new valve will be supplied under the terms of the guarantee. If not fully satisfied that the valves received are equal to any they should be returned within a week, full refund will be made by return of post.

2 Valves or more sent POST FREE. Matched Valves 1/- extra per set. Sent C.O.D. if desired. Ask your dealer for them. Accept no other.

# P.R. PRODUCTS,

33, P.R. HOUSE, NEWGATE STREET, LONDON, E.C.4

(Opposite G.P.O. Tube Station)

Telephone: CITY 3788

**£4 4 0 For 35/-**

**REAL £4 4 0 VALUE**  
The P.R. Speaker at 35/- Cash is marvellous value. No need to talk, try it in your home at your leisure against the best. Clear as a bell—faithful—with a sensitive P.R. Unit. 13 in. by 13 in. by 6 in. real polished Oak Cabinet and Cone. A real bargain. Or if preferred, 5/- down and remit the balance 30/-, or if you prefer it, 2/6 a week for fourteen weeks, 40/- in all. C.O.D. 5/6.



Fit the **DUBILIER** long life **BATTERY**



Other Voltages Available.

Dubilier Condenser Co. (1925), Ltd., Ducon Works, Victoria Road, North Acton, London, W.3

66 Volts

**7/9**

BRITISH MADE

and improve the quality of your reception

Ask your dealer for a copy of the Dubilier Booklet—"A Bit about a Battery."

Cleaver B21

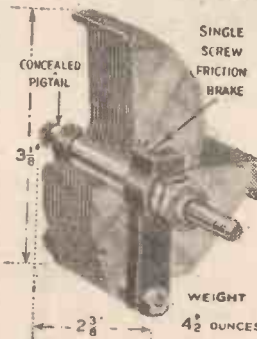

## "1930" LOG CONDENSER

(MID-LINE) As specified for the MUSIC LEADER described in No. 384.

In four Capacities

**4/6** Each

\*Double spacing of vanes for Ultra Short-wave work. As used for the "World-Wide Short-Wave Set" described in No. 387.

## The Finest VERNIER DIAL

obtainable. MECHANICALLY PERFECT. POSITIVE BRASS CONTACT drive on SOLID BRASS SCALE ensuring smooth movement, with absolutely NO BACK-LASH. ROBUST in Construction and Trouble Free. SMALL. EXTREMELY ELEGANT. EFFICIENT.

TUNING WITHOUT IRRITATING UNCOMFORTABLE CROUCH or STOOP **3/-**



Full Catalogue sent post free on receipt of postcard

THE FORMO CO., CROWN WORKS, CRICKLEWOOD LANE, LONDON, N.W.2

# On Your Wavelength!

## How Does it Work?

I SUPPOSE that the question most often asked of wireless amateurs by their non-technical friends is: "How does radio really work?" And, really, it is quite a difficult question to answer, coming in the same category as that other devastating query: "What is electricity?" When I am asked "leading" questions of this type I generally resort to the use of practical analogies. The propagation of sound waves, for instance, is a subject which is parallel in many instances to that of the propagation of Hertzian waves. This analogy is especially useful in the explanation of "tuning" in wireless sets. If two pianos are in a room, for instance, and middle C (or any other note) is struck on one instrument, the like note on the other piano will vibrate in sympathy with the note that has been struck. All the other notes of the second piano are "out of tune" with the actual one played on the first piano, and the equivalent note responds to the vibrations of air pressure coming from a similarly tuned note.

## Fundamentals

In radio, when a receiving circuit is tuned to a distant station its aerial and other tuned circuits offer no impedance to incoming signals, the circuits behaving as though they contain resistance only, the actual D.C. resistance of the wire, etc., used. The generation of electrical oscillations in a valve transmitter (or receiver) may be demonstrated by putting the receiver of a telephone to the transmitter and producing an audible howl. When one gets to rock-bottom facts, this is the principle used by Meissner when he first discovered that "back coupling" grid-to-plate circuits produced radio-frequency oscillations.

## Early Radio Inventions

Most of the inventions which resulted in the first wireless telegraphy transmissions were carried out for entirely different purposes. The work of Clerk Maxwell, Hertz, and Michael Faraday, now recognised as the discoverers of the fundamental principles of wireless telegraphy, was actually scientific research in connection with the speed of light waves. The original coherer type "receivers" were devised for purposes other than radio, such as the detection and measurement of lightning phenomena. Edison first discovered that the filament of his glow-lamp gave off a radiation of "something" in addition to heat and light. Fleming utilised this "Edison" effect for rectifying alternating currents and measuring them with a D.C. galvanometer. De

Forest put the third electrode in the valve without realising that he had evolved an amplifying device. Of all the earlier wireless inventors, Marconi was the only one who really set out to use certain known effects for the purpose of wireless communication, and for this reason he is the true "inventor" of wireless.

## Valve Life

The life of a valve filament is largely governed by the temperature to which it is heated when in use. With the perfection of the dull-emitter filament the life of the average receiving valve has been extended almost to an infinite degree. In the old days bright-filament valves rarely out-lived five or six hundred hours. The heavy-current bright-filament transmitting valves had a longer life than the receiving valves of five or six years ago; a thousand hours was the normal span of most big transmitting valves. Some of the very early valves had robust platinum filaments, which gave poor emission of electrons even when burned almost at melting point. It was found that the emission was very considerably increased by coating the filament with "rare earths" such as were used on gas mantles and limelight pastilles.

## Lamps and Valves

The first three-electrode valves were being developed at the same time as metal-filament incandescent electric lamps, and the progress of the valve was dependent on the improvement of the lamp filament. It was found that tungsten could be heated up to a much higher temperature than platinum in a vacuum without fusing, and, moreover, the inclusion of a certain percentage of thorium in filaments made of tungsten considerably improved their mechanical strength. This type of filament, when used in a three-electrode valve, gave good emission with a comparatively low filament current. The fact that a receiving valve could be made to function on less than 1 amp. of current at five or six volts was considered to be an achievement. This stage was reached just after the beginning of the war. For a long, long time this type of filament, now known as "bright," reigned supreme.

## First Dull-emitters

During the war it was discovered that

certain batches of valves with "faulty" thorium treatment could be used with filaments burning at lower than normal temperatures. Feverish research by the Marconi and Western Electric engineers resulted in the production of valve filaments specially coated with thorium, examples of which were the DEV and DEQ low-capacity valves. The earliest dull-emitter valves were not very reliable, and it was found that if the temperature of the filaments exceeded a certain critical point the thorium evaporated and the emission dropped. This characteristic is, of course, still present in the modern valve, but not to such a marked degree.

## Low-capacity Valves

I can't help feeling a little sad when I think of the passing of the low-capacity type of valve, represented by DEV and DEQ valves, which had filament connections at the top and bottom of a vacuum tube, and grid and plate studs at each side. Meanwhile, the low-capacity valve has been replaced with the standard four-pin type. The first screen-grid valves were a partial return to the DEV method of construction; but, alas, the four-pin holder had secured too tight a hold on the market for any departure from standard practice to become successful!

## Television in New York

I gather from the columns of some American newspapers which have just come into my hands that the people in New York have been very favourably impressed with the television demonstrations which have been recently staged there by some of the engineering staff from Baird's London laboratories. The first demonstration was formally opened by Mayor Walker, who was himself televised, and many notable people were present to see well-known stage and screen stars performing before the transmitter. The artistes included Miss June Colyer, Miss Betty Compson, Miss Irene Delroy, etc. Apparently a wonderful transmitted image was obtained of the violinist, Mayer Gordon, well known as a B.B.C. soloist, but who plays under the name of Manuel Compinsky in America. Every action during his performance was faithfully reproduced.

## A Periscopic Scanner

For the first time in commercial television practice, a device called the periscopic scanner was used which had been invented by the Baird Television Corporation of America. By its use it is possible instantaneously to accommodate the scan

## Next Week:

"Brookman's By-Pass 3"

A Set incorporating its own Wave-trap

::                      ::                      **On Your Wavelength! (continued)**                      ::                      ::

to any type of subject, whether seated, standing, or moving about. In addition, the operating engineer can select and transmit at will the more interesting portions of any studio scene.

It is rather curious that I should have predicted the use of such an arrangement in conjunction with the "spotlight" mike that I mentioned in these columns only a week or two ago. Full details of the scanner are not yet available, but I understand it works on a special mirror principle, whereby the normal scanning light strip beams are moved horizontally or vertically by an ingenious mirror arrangement. Undoubtedly the perfection of such a device will remove one of the objections often levelled at television, namely, restriction of subject and scene. I hope to be in a position to give details of the invention at an early date.

#### **An Historic Event**

A good many years ago now, when broadcasting was quite in its infancy, I wrote an article whose theme was that not many years would pass until one man could speak to the whole world. A few minutes before I began to write this note I was listening to one man, in the person of His Majesty King George V, speaking to almost the whole world. When the King opened the Five-Power Naval Conference in the Royal Gallery of the House of Lords on January 21, 1930, he made history in more ways than one. Not only did he inaugurate a conference which may have far-reaching effects upon the progress of civilisation, but he also addressed the largest audience that has ever been able to listen to the words of one man.

#### **In Days to Come**

Now that we have found it possible for the Empire and the world to hear the spoken words of the head of the British Commonwealth of nations, let us hope that more and more use will be made of the wonderful possibilities of the wireless link between ruler and peoples. Nothing can bind the Empire more closely together than words addressed to every one of its members and heard by British subjects in their own homes the world over. Wireless has shown already what it can do in this way. In time to come we must see that full use is made of the link that it has forged.

#### **New DX-ers**

It has surprised me to find lately what an increase there is in the amount of listening done to Continental stations. People who used to be content with the local or 5XX have now awakened to the fact that if they have a good stage of high-frequency amplification there are quite a number of Continental stations from which first-rate

programmes are obtainable. This is all to the good, for there is no question but that long-distance reception is one of the most interesting parts of wireless. Most people rely upon one or other of the home stations as their staple provider of entertainment, but very great pleasure is to be obtained from hearing something of the foreigners.

The kind of searching that I don't recommend consists in seeing how many stations can be logged in half an hour or something of that kind. Vienna is tuned in and three bars of "The Blue Danube" are heard. A tick goes against Vienna in the log, and the dials are twiddled until Brussels turns up. One sentence of the news bulletin, another tick, and off goes the express searcher to Milan. That sort of thing may be amusing, just once in a way, but it is not real wireless.

#### **The Wise Way**

The best of all ways of using the set for foreign listening is this. Make a list first of all of the stations that are most likely to be heard with good volume. Working up from the bottom of the medium-wave band, I would suggest Cologne, Münster, Nürnberg, Königsberg, Turin, Göteborg, Hamburg, Toulouse, Frankfurt, Kattowitz, Rome, Oslo, Brussels, Vienna, and Budapest. These stations are generally amongst the best, though in different localities some of them will probably go out, whilst others will come in in their places. For the long waves the list might include Hilversum, Kalundborg, Motala, Königswusterhausen (Zeesen), Radio-Paris and Huizen. Experience will show which of these stations are the most reliable, and any that do not, as a rule, come up to the scratch can be weeded out. Remember that in listening to foreign stations the two most important points about a transmission are signal strength and freedom from interference. A small heterodyne will undoubtedly spoil the pleasure of listening to an item, and reception of good quality is impossible if a transmission is so weak that the set must be kept almost on the verge of oscillation. The number of first-rate stations will probably be whittled down eventually to three or four on the long waves and, say, half a dozen on the medium band. When you want to take a trip abroad, choose one of these that is giving a good programme, tune it in, and listen to it for a reasonable time. Don't flit like a butterfly from flower to flower.

#### **The Modern Aerial**

Though recruits to the wireless army are joining up at the rate of about forty thousand a month, one does not see many new outdoor aerials erected. People nowadays much prefer the frame, whether used as a separate component or built into the

receiving set. And if they don't use a frame, they rig up, as often as not, some kind of indoor aerial. With the efficient receiving set of to-day, containing one or two good H.F. stages, the outdoor aerial is completely unnecessary and very often it is a positive drawback. A long, high wire suspended over the garden certainly does bring in stations at great strength, but it also brings in mush, atmospherics, spark signals, and so on. In fact, the better the aerial from an efficiency point of view, the bigger nuisance does it become from the way in which it collects atmospherics and sparks. If you must have an outdoor wire I would strongly recommend you to keep its roof quite short and it should certainly not contain more than one wire. The only case in which a long roof is required, with perhaps two or more parallel wires, is when a crystal set is used or a valve set without H.F. amplification by one who lives just on the verge of a service area. In such cases the local station only is used, and it is obviously advantageous to obtain the greatest possible strength from it. An aerial from 25 ft. to 30 ft. in height with a very short roof is good all round.

#### **Inside Out**

I couldn't think what had happened to my receiving set the other day, for, though everything appeared to be in good order, all it would bring in on the medium band was 2LO, and that at very poor strength. When the wave-change switch was flicked over it would bring in 5XX, but it wanted to howl, which it never does in the ordinary way. I was distinctly puzzled, for measurement showed that the proper amounts of filament and plate current were passing, and further tests proved that every circuit in the set was in thorough working order. The loud-speaker was all that it should be, and the valves had only recently been tested and found to be in excellent condition.

#### **Simple!**

I wonder if, without reading any further, you can guess what had happened? I will put you on the scent by telling you right away that it was something remarkably silly. Made your guess? Well, here's the answer. On looking behind the cabinet, I found that one of my young hopefuls in connecting up had attached the aerial lead to the earth terminal and the earth lead to the aerial terminal. That was all; but I can assure you that it was quite enough. The wonder is that anything at all came through with the set in this inside-out condition. Of course, in a crystal set—at any rate, with a single-circuit tuner—it doesn't make any difference which way you connect up the aerial and earth. In a valve set it does. THERMION.



A PAGE FOR THE SET-BUYER

# THE EDISWAN

## STANDARD BATTERY-OPERATED RECEIVER

*In this, the first of a new series of weekly articles of special interest to the set buyer, our contributor, "The Set Tester," draws attention to the low first cost, economical working, and general all-round efficiency of the Ediswan battery-operated set*



The fabric-covered metal case of the Ediswan receiver is an innovation

**I**N spite of the increasing use of electricity, or because of its present limited distribution, most listeners still have to use battery-operated sets. Apart from portable sets, the manufacturers seem to have devoted most of their energies to the development of all-electric sets. This is a pity, when so few listeners can take advantage of mains-operated sets. I am all in favour of sets worked from the electric-light mains, but until electricity reaches the stage of distribution promised by the Central Electricity Board, I think more attention ought to be devoted to battery-operated sets.

At present, the range of really good battery-operated sets is surprisingly limited. I hear from one or two well-known firms specialising in such sets that

*Every set referred to in this regular feature by "The Set Tester" has reached a certain standard of efficiency in the "Amateur Wireless" Laboratory. Reports are not given on sets that fail to reach this standard. This will explain why reports that do appear always express general satisfaction with the set's performance.*

set must be what advertisers call a strong selling point. Complete with the three valves, the set retails at £9 12s. 6d.

Clean-cut "lines" in wireless sets are beginning to be appreciated; the Ediswan set is good to look upon. The fabric-covered metal case is an innovation. I suppose this was done to keep down the cost of production. The result is extremely pleasing. The set looks very much more distinguished than most cheap sets having orthodox wooden cabinets.

The controls are mounted on a large escutcheon plate. Probably because I have a strong aversion to small fiddling controls, I was especially pleased with the robust knobs and switches of the Ediswan set. Two thumb-control discs have to be operated to tune the aerial and screen-grid valve circuits. The dials are easy to read and smooth in action. There is not much discrepancy between the readings. The reaction knob and wave-change switch are equally robust and positive in action.

In a battery-operated set the total H.T. consumption is a matter of great importance. Standard-capacity high-tension batteries (which most dealers seem to stock for every conceivable type of set!) soon run down if the anode-current consumption exceeds 7 or 8 milliamperes. This will not happen with the Ediswan set, because I find that the total anode-current consumption is only 7 milliamperes, using the three Ediswan valves supplied with the set. The Ever Ready Winner type 120-volt battery, costing 14s., was used for the test. Such a battery would give reasonable service with the Ediswan set.

I made a special point of determining the degree of selectivity of this set. There is no doubt that the two tuned circuits in this set are well designed. They impart a degree of selectivity well up to the standard likely to be required within "regional" areas. I was able to tune out the Brookmans Park transmission at Fetter Lane within 5 or 6 degrees on either side of the maximum tuning point. On the long waves Eiffel Tower was received quite clear of 5XX. This is a good indication of the selective properties of the set.

### Good Quality

Quality of reproduction is up to standard; of course, a lot depends on the loud-speaker. I used the new Brown Vio Duplex, which gave very pleasant reproduction.

Ease of operation, thanks to the robust controls, is a feature of the Ediswan set that I would specially commend to the set buyer. An hour or two at the dials should enable the veriest novice to master the set and to get excellent results from it.

Acting upon the suggestion of a Scotsman living in Hawaii, a San Francisco newspaper broadcasts every week the results of the leading football matches in Scotland. The news bulletins of this journal reach a very wide public, extending to Canada, Alaska, Hawaii, Mexico, and even New York and Florida.

Miss Esme Moonie, who comes of a family of musicians and educationists well known in her native city of Edinburgh, has just been appointed to the advisory staff of the Canadian National Railways Radio Department in Montreal. Miss Moonie is a graduate of London and Edinburgh Universities.

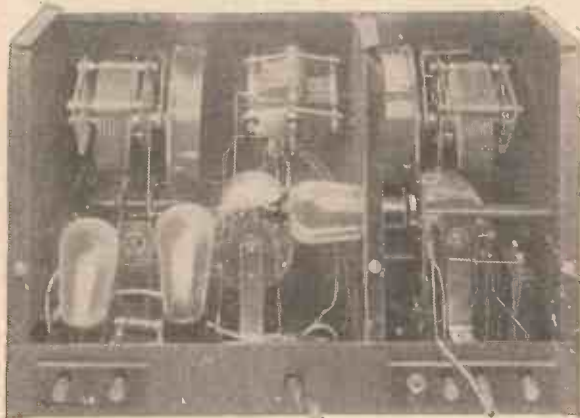

This rear view shows the neat internal arrangement of the components

a combination of screen-grid high-frequency amplifier, detector, and power valve is a strong favourite.

### A New Three

The Ediswan people launched out this season with a complete new range of sets. Among them I found the "Ediswan Standard Battery-operated Three-valver," which interested me sufficiently to make me want to test it. This I have now done; my experiences are passed on to set-buying readers of AMATEUR WIRELESS.

The exceptionally low cost of the Ediswan

# TRANSFORMER BUILDING AT HOME

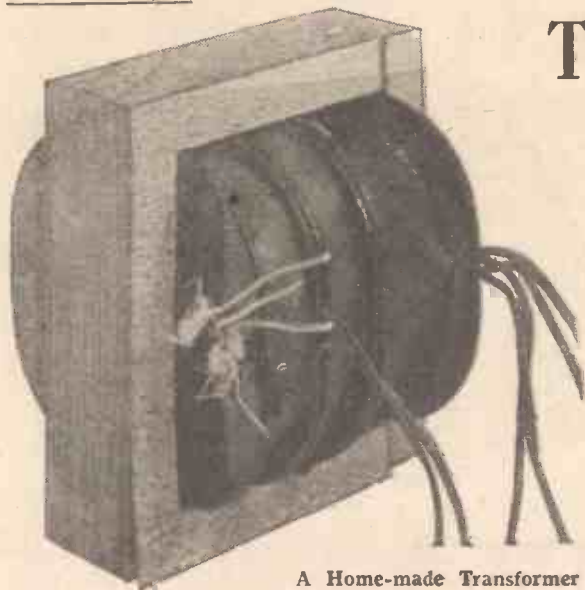

A Home-made Transformer

With the increasing use of lighting mains for wireless purposes many listeners require information on the construction of accessory apparatus. In this article W. JAMES explains the building of mains transformers, work within the ability of any amateur

THE question generally asked by those considering the construction of a mains transformer is, "How many turns of wire shall I have to put on this core?"—the core referred to being perhaps from an old intervalve transformer or choking coil, or from some other damaged component bought somewhere for a few pence.

This is a really practical question to ask and shows a certain amount of knowledge. But, unfortunately, the question cannot be answered directly. The number of turns is only one of several vital factors.

First, we must know the voltage of the supply and its frequency. Further, what is the transformer for? We cannot decide on the size of the wire until the current which will flow is settled. This in turn depends upon the efficiency of the transformer, as well as upon the voltage of the secondary and its current.

We had better, therefore, start at the beginning and learn how the various factors are taken care of. The first is the voltage of the supply. If this happens to be 110, then the number of turns in the primary winding, which is the one connected to the mains, may be exactly half the number for a 220-volt supply. In other words, the number of turns of wire included in the primary depends upon the voltage of the supply.

If too few turns are used an excessive current will flow and the transformer may "burn out." The higher the voltage, the greater the number of turns that must be used. This is the first point to be remembered.

The second point concerns the frequency of the supply, and the rule here is that fewer turns are needed for a higher frequency. Thus a transformer made for a 25-cycle supply must have twice as many turns of wire in its primary as another

are of 50 cycles. The next point has to do with the size of the core and particularly of the cross-sectional area of that part upon which we wind (see Fig. 1). What is its area? Is it one square inch or only half a square inch? For, if it is the latter amount, exactly twice as many turns of wire will be needed in the primary.

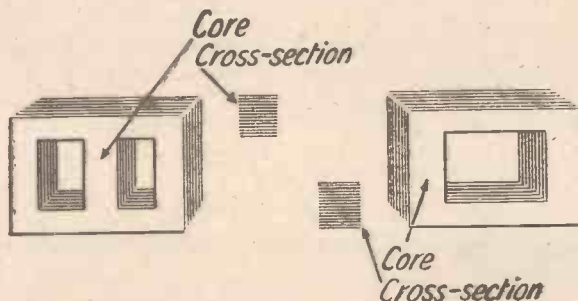

Fig. 1. Two core types, showing cross-sectional areas

Fewer turns are needed for a larger core, and in this connection what matters is the section of actual iron, and not its apparent area. Thus, if the laminations are not packed very tightly together the actual area may be only 70 per cent. of the space occupied. Moreover, even when the laminations are tightly packed, possibly 10 per cent. or more of the space is not iron, but

partly air and partly the insulating material on the surface of each lamination.

These facts ought to be remembered, or one may make the mistake of not allowing adequate core area.

We have now discussed three factors—supply voltage, frequency, and size of core—and before passing on we ought really to discuss the effect of different core materials. It is not necessary to enter into details of core materials, however, as we will assume stallo to be the material. This is widely used, but it will perhaps be as well to say that the number of turns or the cross-section to be employed is dependent to an extent upon the characteristics of the core material.

### Winding Data

Now, given a stallo core, how many turns should be used for a 50-cycle supply? My experience teaches me that 7 turns per volt on a core having a cross-section of 1 square inch is suitable. For safety, one could reckon 8 turns per volt, in case the core is a little under 1 square inch and is not properly assembled. Air gaps in the core are dangerous, as they tend to reduce its effectiveness, and if the core were poorly put together an excessive current might flow and damage the windings. It is;

therefore, essential that the laminations be properly fitted as illustrated; but, for safety, let us allow 8 turns per volt.

The turns per volt for other cross sections may be obtained by proportion. Thus, for a core of 2 square inches 4 turns per volt would be satisfactory, and for a small core of half a square inch 16 turns per volt are necessary. From these figures it follows

that for a core of 1 square inch the numbers of turns for various voltages at 50 cycles would be:—

Supply voltage	Number of turns in primary
100	800
200	1,600
210	1,680
220	1,760
230	1,840
240	1,920
250	2,000

As regards frequency, either turns or cross-sectional area should be doubled for 25 cycles or halved for a 100-cycle supply.

(Continued on page 198)



This photograph shows the essential parts of a mains transformer before assembly. In this case two secondaries are used to provide two different outputs

# WIRELESS TO LOCATE VALUABLE MINERALS

*A Simple Explanation of the Methods used.*  
By Cedric W. Marshall

SINCE the year 1915, some twenty British patents have been secured, largely by foreigners, for electrical underground survey methods in which wireless practice plays an interesting part.

The methods are divisible into two classes, ground circuits used for local subterranean exploration and radio circuits for extensive survey, deposits of a conductive nature as coal, water, and metallic ore being detectable. In this article a résumé of the representative methods with a general scheme of operation will be given.

For small area survey a portable generator supplying a circuit with potential divi-

minium rectifier cell, then to a neon lamp finally to a metal probe with insulated handle.

Wireless methods for surveying large tracts of land are necessarily more elaborate. The emitted waves must be long, for penetration, but whole continents may be explored with fair rapidity.

Waves from an aerial some 650 feet long are sent through the earth, reaching, on account of its curvature, a very good depth.

### Semi-static Methods

Semi-static exploration is shown at A, in Fig. 2, the transmitter being placed

utilising aerial inclination to ascertain depth as shown in Fig. 3, according to the received signal strength.

The nature of the deposit is ascertained by the geological formation, as far as possible, coal, water and metal being thus fairly distinguishable, iron again being differentiated by the use of magnetic detecting devices such as the fluxmeter or compass apparatus.

No information is to hand regarding chemical or oil detection, but again, the nature of the land is a fair indication, though in the latter case, an opposite reaction to conductors, using electrical apparatus, should be obtainable.

During the war methods of submarine detection, applicable to sunken bullion were prominent and regarding such underwater exploration two methods are shown by Fig. 4.

At A, a ship is fitted with an electro-magnet in the bows, the waves from which pass underneath and are received by a coil in the stern.

B shows an iron-hulled ship wound with insulated wire cable connected to a source of power, thus forming a large cored coil, whose magnetic flux would be easily affected by adjacent metallic masses.

A systematic survey by electrical means can now be described. A base line of operation is found by the method of Fig. 2, which

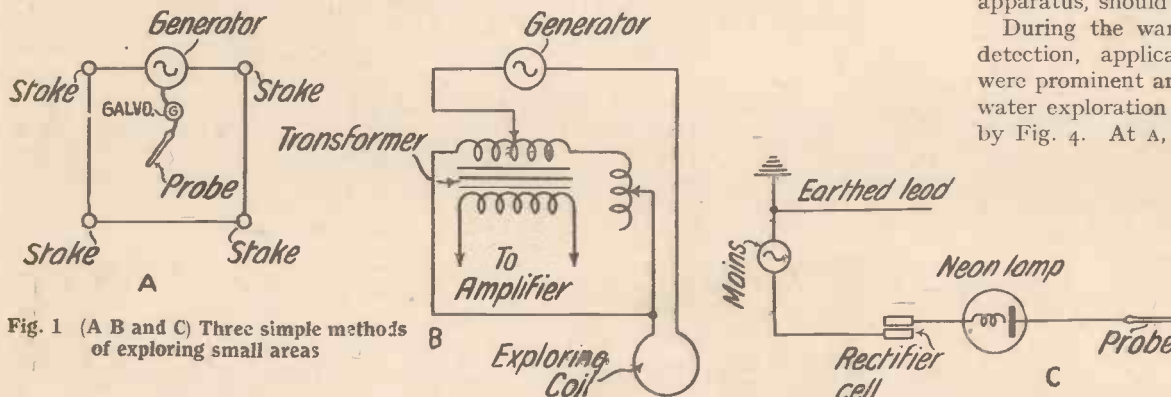

Fig. 1 (A B and C) Three simple methods of exploring small areas

sion is used, two modifications being applicable.

### Methods for the Amateur

Fig. 1 shows, at A, a circuit having four earthing stakes which are placed at the corners of the ground for exploration, and a central lead connected to a galvanometer and a fifth earth stake or probe. Current being on, the ground surface is covered by the probe, the galvo reading indicating the presence and either depth or amount of any conductive deposit, while the area of such is mapped, in addition, by probe movement. B shows a more convenient use of the potential circuit in which a large coil, without earthing and with amplified telephone detection takes the place of the probe and galvo. The circuit is first balanced by means of a rheostat so that no telephone hum is audible, then on passing the coil over the ground surface, a phone note is perceived when over a conductive mass, the depth or amount being registered in terms of rheostat adjustment necessary to cancel out the note.

Amateur experimenters will realise that the foregoing methods are easily applicable to their gardens (!) as is the method shown at C, in which the unearthed lead of the supply mains is connected to a lead-alu-

minium rectifier cell, then to a neon lamp vertically in a bore hole while the mobile receiving apparatus is moved round the zone of reception in diminishing circles, as at C. At B the aeri-als are carried between uniformly moving pairs of ships which travel parallel to each other along opposite coast lines, or, if convenient, along rivers. Dot signals are used and when reception is interrupted the presence of intervening

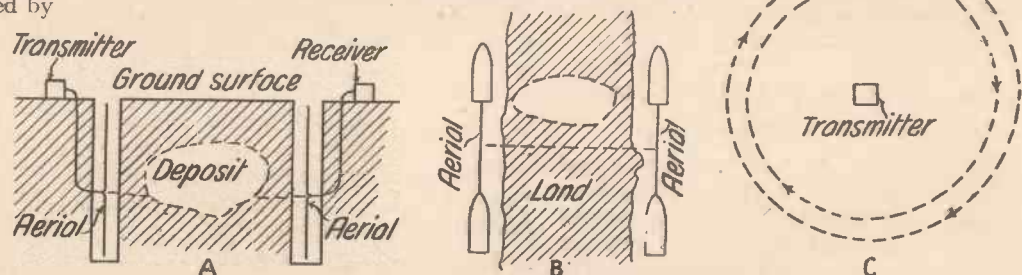

Fig. 2. (A B and C) Semi-static methods of exploration

conductive deposits is suspected, the radio waves acting upon large conductive masses analogously to a light beam which strikes a mirror. The receiver signals back the interruption and parties may then set out along the communicating line with local detectors.

### Ascertaining Depth

The property of reflection is taken advantage of in a triangulation method

gives a belt of exploration some 200 metres wide.

This is then explored by two vehicles towing insulated trailers which carry the coil exploring apparatus of Fig. 1 and also the triangulation installation of Fig. 3, the latter for the intervening, the former for the ground directly underneath; the vehicles move uniformly and parallel along the belt borders. The vertical line

(Continued at foot of next page)

# "A.W." TESTS OF APPARATUS

Conducted by our Technical Editor, J. H. REYNER, B.Sc.(Hons.), A.M.I.E.E.

## Neat Igranic Switch

**I**GRANIC push-pull switches are well known to readers on account of their special action, which ensures a rapid make and break. A quick break is a great advantage for electrical work, for it prevents arcing and its attendant evils, such as burnt contacts.

We have recently received for test and report a special pattern of the Igranic



A neat Igranic switch

Q.M.B. push-pull switch adapted for mains work and capable of carrying currents up to 2 amps. continuously. The switch can be mounted on the panel by drilling a single hole, or, if preferred, screwed down to the baseboard. A substantial insulated knob is supplied in place of the usual metal knob, and connections are taken to metal legs, with soldering tags attached.

In its most essential form the operation of the switch consists of a double-action spring-loaded plunger, ensuring a clean make of negligible resistance and a rapid break. The switch is pleasant to operate and goes into position with a reassuring "click." All the working parts are completely enclosed in an insulated container and are, therefore, not liable to damage.

## Cifel Junior H.T. Eliminator

**W**E have received for test a neat and compact A.C. mains unit known as the Cifel Junior. This is of the double-wave valve-rectifier type and is intended for delivering 10 to 12 milliamps at 120 volts. The whole unit measures 7½ in. by 4½ in. by 6½ in. high. The connec-

tions and variable controls are brought out to an insulated panel on the front of the instrument, the eliminator being housed in a metal case having a hole in the top through which the valve is inserted.

The sample we received was provided with two input tappings either for 210 or 230 volts and two output tappings, one of which is fixed and rated at 120 volts, while the other is variable around 60 volts and is intended to be used for providing the voltage on the screen of an H.F. valve or for the detector tap. This latter voltage is obtained by a series-feed resistance from the 120-volt tapping, a portion of this resistance being variable and controlled from the panel.

In operation we found the eliminator quite silent when tested on a two-valve set. The voltage on the maximum tapping was 142 at 10 milliamps, at 120 volts the output being 10 milliamps, rising somewhat



Cifel Junior H.T. eliminator

rapidly as the load was removed, the no-load voltage being 300. Care should be taken, therefore, never to leave the eliminator on unless the set is switched on in order to avoid a high voltage, but with this precaution the eliminator is suitable for use on the ordinary two- or three-valve set.

This eliminator is marketed by Messrs. Fonteyn & Co., Ltd., of 2-4-5-6, Blandford Mews, Baker Street, W 1.

## A Useful Portable Accessory

**T**URNTABLES for portable sets form an added convenience that few who

have tried them would care to relinquish. The chief reason for their utility may be attributed to the ease with which they allow a set to be rotated into the optimum plane of reception without any necessity for lifting.

One of the most useful and adaptable types of turntable is that made by Messrs. The Benjamin Electric Co., Ltd., a sample of which has been sent in for test. The

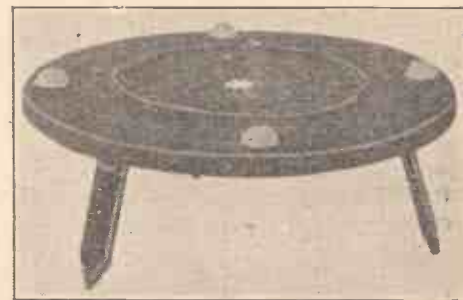

Benjamin portable set turntable

turntable itself is made of metal and has an attractive brown crystalline finish. Four rubber buffers are mounted on the top table in square formation, 5 in. apart; they prevent damage to the woodwork of the portable set and also grip the instrument securely.

A particularly novel and useful feature of the turntable is the provision of collapsible legs, which, when in use, will hold the set 3 in. off the ground. As the makers point out, this is a valuable feature for outdoor work where it is desirable to reduce the capacity between the aerial and the earth; also, due to the pointed ends of the legs, a good grip is obtained on grass or soil. When these legs are folded for indoor use, the turntable rests on substantial rubber buffers, thus preventing damage to furniture on which it is placed. These legs and buffers are mounted on a subsidiary turntable capable of rotation on the main axis. The movement is sufficiently damped to prevent swinging.

This is a most useful article and those readers who possess portables can be recommended to purchase a Benjamin turntable.

## "WIRELESS TO LOCATE VALUABLE MINERALS" (Continued from preceding page)

having been found, drilling is commenced with a special tool having its point connected in circuit with a supply and earthing so that actual contact with conductive material may be perceived.

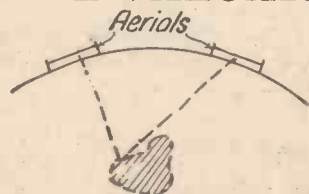

Fig. 3. Triangulation method of location

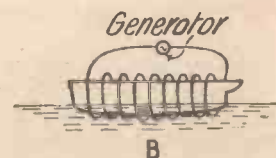
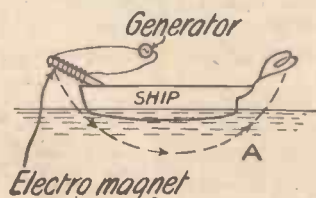

Fig. 4. (A and B) Method of submarine location

# WITHOUT FEAR OR FAVOUR



## A Weekly Programme Criticism by Sydney A. Moseley

WHAT is behind the idea of these revised Sunday programmes? I imagined, on reading the announcement, "Special programme at 2 o'clock," that my recent protest had been of some avail. But this "special programme" turned out to be the Brookmans Park relay, and although thousands must have been listening, all we were given were readings (plural, Mr. Printer!) from "Silas Marner" and some "thin" pianoforte solos.

Really, sometimes there is a lack of perspective in the LOLy of 'olies.

Give us back our old orchestral concerts at 3 o'clock, or even 2.30!

When debates are formal they are decidedly formal. When, on t'other hand, an effort is made to be informal—it becomes chaos.

The motoring speed debate offered obvious meat for either protagonist. It was dignified and serious, but spoilt

1. By being too long;
2. By childish interruptions;
3. By an inability to recognise when it was over.

In most debates there is always one who is aggressive and over-powering and who would like to do *all* the talking. Those who heard the debate will appreciate this point. Also, one of them said, in the manner of the debating society, that he had a good deal more to say, although he had actually repeated himself *ad nauseum*.

I fear these debates must be shortened and formally (and firmly) closed by the announcer.

Mabel C. and Michael H. once more gave us good, clean fun. *The Whale* is not their best; however, it certainly is a good deal better than other sketches we could name.

Good idea to give us the Edward German programme. *Mervie England, A Princess of Kensington, Tom Jones, Henry VIII,* and *The Emerald Isle* afford bright and sparkling music.

Bransby Williams is delightfully intimate with the "mike." With a few words he banishes the formality of the studio and creates that fireside atmosphere which eludes so many artistes. His impersonations are always good, but he hit the high spots with his George Graves. That was "George" all right.

Female duettists, as my regular readers will know, do not gain many plaudits from me. They invariably make my speaker rattle. But I must award a bouquet to Oonah Mairs and Yvette Darnac for some prettily rendered songs. The old Italian love song, a song in Gaelic, and a dainty French melody were all good.

There is never much new about Will Hay's sketches, and yet they always raise plenty of laughs. It struck me, while listening to his latest—the one about a new pupil named Ewers—that it must be clever to get so much fun out of a slight play on words. Personally, I think Will Hay must be seen as well as heard.

If Flotsam and Jetsam will give us a change from their now well-known repertoire, by including such a gem as "On the Road to Mandalay," they will deserve well of us.

The usual fight between the dance orchestra and the announcer continues—the orchestra still winning. I notice that constructive hints in these columns are acted upon after they have been repeated for some months. So, here's hoping!

The orchestral concert by the Wireless Symphony Orchestra, conducted by Percy Pitt (with one hand to his ear), was, as usual, first-rate. And there were Norman Allin, incomparable of basses, and Albert Sammons, master of violinists.

Note to new recruits of symphony concerts: *Don't clap between movements.* It is not done.

Herewith a note from a dance-band expert:—

"Jack Padbury's Cosmos Club Six is a perfect example of a good small band. I have just heard them backing a vaudeville show, and I imagine that they filled the bill every bit as well as Jack Payne's big band. I only wish that some of the people who say nasty things about a saxophone would listen to Jack Padbury."

How realistic are the words of Kipling's song, "Boots"! Every ex-army man, and everybody who has seen soldiers on the march, must have thrilled to the sound of Ernest Butcher singing that realistic song.

I must pay tribute to Angela Maude for her clever turn. Here is a young lady with talent, and I hope she gets a good many more opportunities to appear before the "mike."

The French liner *Paris*, for a brief period after leaving port on her voyage to New York, recently steered her course without other aid than that of wireless signals.



Eric Cowley as our cartoonist sees him

FREE SUPPLEMENT—Presented with  
No. 399 of "AMATEUR WIRELESS," February 1, 1930

# The BROOKMANS' BY-PASS

FOR DETAILS OF BUILDING & USING  
SEE "AMATEUR WIRELESS" FEB. 1<sup>ST</sup>. 1930

**BLUEPRINT N° A.W. 218**

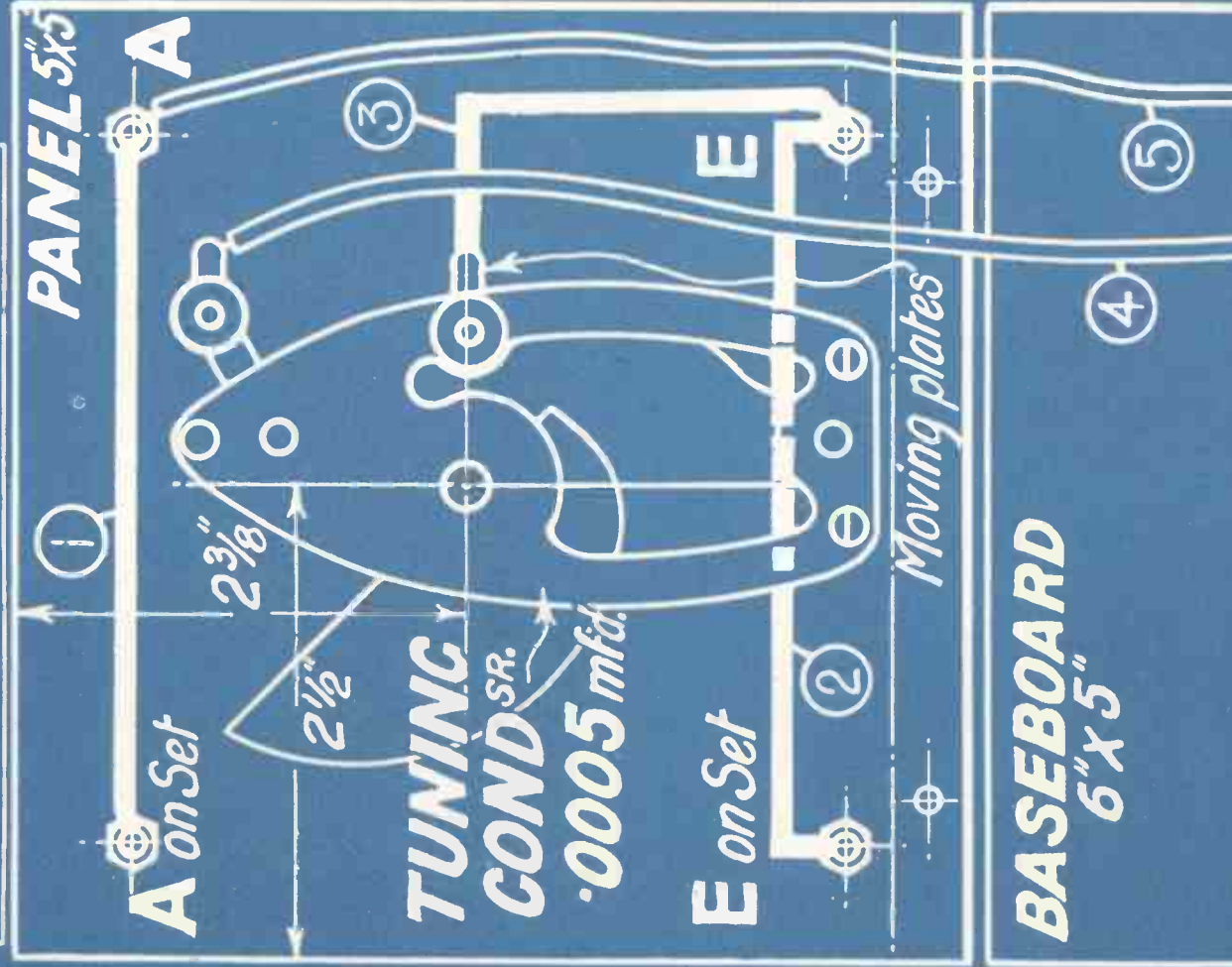

# TAPPED COIL

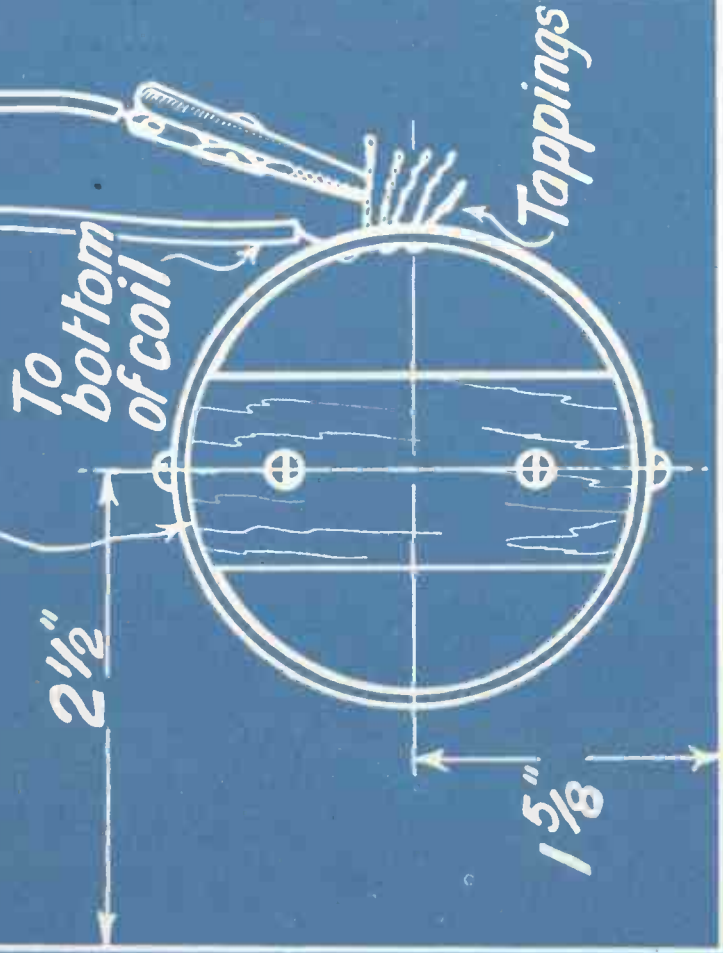

Checked by - *J.H.*

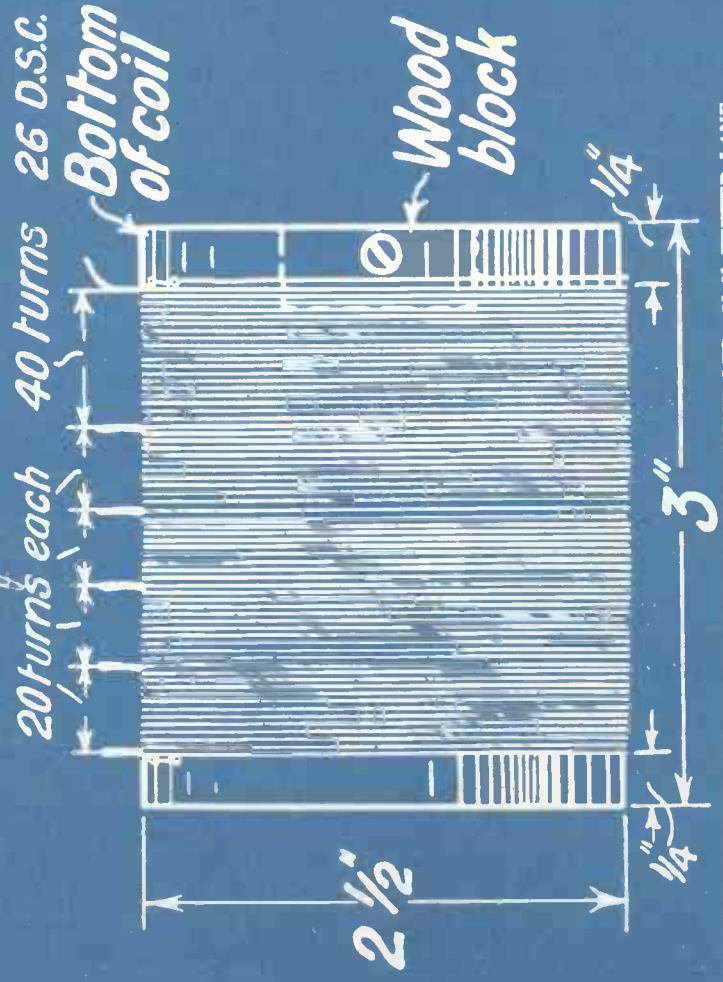

THE possibility of using a by-pass circuit to cut out the interference from a powerful local station was discussed in last week's article, which dealt with some of the preliminary experiments leading up to the production of the "Brookman's By-pass." As was stated in that article, the ordinary methods of obtaining the desired results were tried and were discarded as being inadequate, and attention was turned to the by-pass or acceptor type of trap.

**Wave-trap Disadvantages**

This consists of a tuned circuit connected across the aerial and earth terminals of the set in accordance with the circuit shown by Fig. 1. Let us now consider what happens to a signal picked up on the aerial. When it reaches the set it has two alternative paths. One of these is through the set itself and the other is through the tuned circuit. Now, the tuned circuit has a high-impedance at high frequencies except those in the neighbourhood of the resonant point. Therefore, normally this shunt has little effect on the signal strength, since most of the energy passes through the receiver in the ordinary manner.

At the resonant point, however, the inductance and capacity tune to the particular frequency being received, and the



The unit is easily attached to any receiver

impedance of the shunt circuit is simply the resistance of the coil. The effect of the inductance is completely cancelled by the effect of the condenser, and we are left simply with a small resistance of a few ohms only. This obviously acts as a heavy short-circuit across the receiver and the majority of energy is by-passed straight to earth.

**A Wonderful Improvement**

Now, this simple type of trap gave extraordinarily effective results when tried at the laboratories, which are only about

# BROOKMAN



five miles from Brookmans Park. No ordinary trap was of real use when employed with a full-sized outdoor aerial, but this arrangement was effective in cutting out the transmission from Brookmans Park completely. Considering that the voltage actually induced in a full-sized aerial system at Elstree is in the neighbourhood of one-tenth to one-fifth of a volt, this is a really astonishing performance. It was clear,

Experimental traps have been made up and

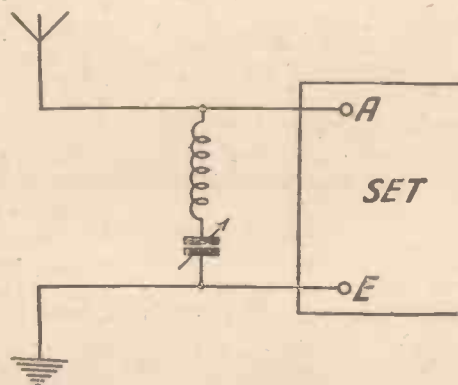

Fig. 1. Simple acceptor circuit

found partially successful, but altogether too severe, and in the absence of any satisfactory method of controlling the action, they were discarded.

We examined the theoretical action of the trap, however very carefully in order to find whether some solution of the difficulty could not be found, and the answer proved so simple that we almost hesitated to put it to the test. I hope to discuss the real action of this by-pass in future articles, but it will

however, that the by-passing action, while excellent for those living close to Brookmans Park, would be too drastic for readers living farther afield. It was necessary to devise something whereby the severity of the action could be modified to suit various requirements.

This is a problem requiring a certain amount of ingenuity, for the action is essentially different from that of the usual rejector type of arrangement. In fact, this type of trap has never come into popular favour because of this very factor.



By J. H. B.Sc., A



This plan view shows construction

be sufficient to point out the necessity of the trapping entirely by the relative



# Brookman's BY-PASS

**SOLVES YOUR  
SELECTIVITY  
PROBLEMS**

inductance and con-  
denser used.

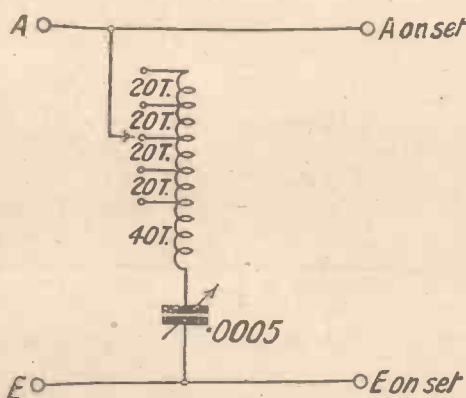

Fig. 2. Circuit of the "Brookman's By-pass"

If we have a small inductance and a large condenser, then the trapping is very effective, because the high-frequency resistance of the circuit is small; on the other hand, the spreading effect is somewhat marked and stations a considerable distance on either side of the trapping point will be reduced in strength.

If, on the other hand, we make the inductance very large and the capacity correspondingly small, the width of the band of frequencies which is by-passed

becomes very small, so that the action is extremely sharp. On the other hand, due to the large inductance, the high-frequency resistance has increased. The by-passing at the actual tuning point is therefore not quite so severe and the

reduction in strength of the station actually being by-passed is not so marked.

This is exactly what we require. A reader living close to Brookmans Park or a similar powerful station desires a particularly effective by-passing action and he is prepared to put up with a fairly broad tuning, provided the band width is not too great. A reader living farther away does not want such a severe action, but does require a narrower band width, and both of these effects are obtained by the simple expedient of using a larger inductance.

### The Practical Trap

The form of trap as finally made up, therefore, simply consisted of the circuit shown by Fig. 2, wherein we have an inductance having a number of tapings so that

the best tapping for the particular requirements can easily be found by trial. Experiments were first made with plug-in coils of the standard two-pin type, but it was found necessary to discard these, owing to the fact that the self-capacity was too large. Where one requires a large inductance, only a very small capacity is necessary to tune it, and this may be quite comparable with the self-capacity of the coil. If this is the case the circuit will not tune properly. A simple solenoid coil, therefore, was made up consisting of a single-layer winding on a 2½-inch former and tapings were taken every few turns in order to give a wide range of selection. Thus, the best operating condition can be found with ease and rapidity, while the coil itself, even if purchased ready made, is no more expensive than a plug-in coil.

### Construction

For the same reason it has not been found possible to use one of the compression types of condenser, such as the Igranic pre-set or the Formo-densor. The minimum of

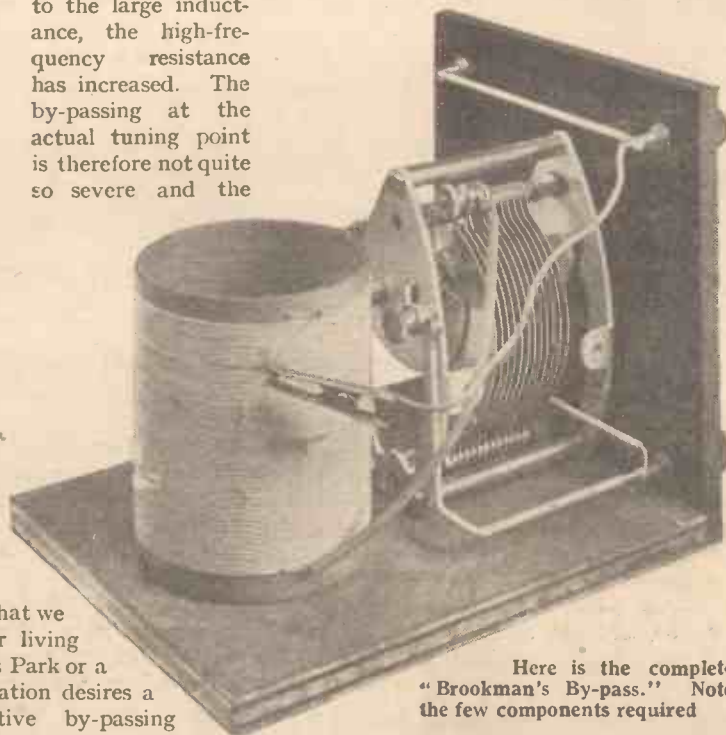

Here is the complete "Brookman's By-pass." Note the few components required

these condensers is too high to permit of satisfactory tuning when a large inductance is employed, and therefore a condenser of the normal type has been used. While this is slightly more expensive, its advantages more than outweigh the small extra cost.

Referring now to the construction, this is of the simplest possible character. The coil is the first portion to be made, and this is done by taking a 2½ in. diameter former 3 in. long, which should be of Paxolin, Pirtoid, or some similar material. First of all, drill four holes, two at each end.

REYNER  
M.I.E.E.

how simple is the  
action

out that the sharp-  
action is determined  
tive values of the

**"THE BROOKMAN'S BY-PASS"** (Continued from the preceding page)

These should be small holes, just to push the wire through, and in the absence of a suitable drill they may easily be made with a sharp nail or a stout pin. Next, you will require 1 1/2 ounces of No. 26 s.w.g. double-silk-covered wire. Wind this on the former leaving a length of about 6 in. at the end for connection to the variable condenser. Wind on 40 turns first of all, and then take the first tapping.

This may be done in the following manner. Place the finger on the winding to prevent it from unravelling again. Make a



Another picture which shows clearly the construction of the "By-pass"

small loop of wire about 1/2 in. long and twist this loop round two or three times. Then, on continuing the winding, the loop will stand clear of the winding.

Continue in this manner, taking tappings every 20 turns, until a total of 120 turns has been wound on. We shall thus have a winding of 120 turns in all, with tappings at 40, 60, 80, and 100 turns. When the

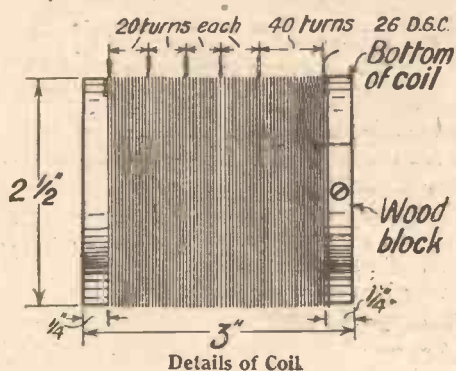

winding has been completed the insulation may be removed from the twisted portions, thereby enabling tappings to be taken with the crocodile clip, as shown in the diagram.

If desired, the coil may be obtained ready-made from such firms as Harlie Bros., Wright and Weaire, etc.,

This coil is then wired up in series with the condenser. The condenser is mounted on the panel, together with four terminals for convenience. The top two terminals are connected together, and so are the bottom two. A flex lead is taken from the left-hand top terminal, this being terminated in a crocodile clip to enable it to be attached readily to the tappings on the coil. The bottom end of the coil is connected to the fixed plates of the condenser and the moving plates of the condenser are connected to the bottom left-hand terminal. In mounting the coil on the baseboard, care should be taken to see that the 40-turn portion is at the bottom of the coil, so that all the tappings are at the top.

The "Brookman's By-pass" should be connected as shown by Fig. 3. The aerial itself is taken to the left-hand top terminal, while the right-hand top terminal is connected to the aerial terminal on the set. Similarly, the earth lead is taken to the left-hand bottom terminal, the right-hand bottom terminal being taken to the earth terminal on the set. Now tune in the receiver to Brookmans Park (or whatever station is to be eliminated) and gradually rotate the dial on the by-pass. At one particular point, the strength will be found to be considerably reduced, and this is the actual by-passing point.

It is best to start on a fairly low tapping. That is to say, the crocodile clip should first be connected to the 40-turn tap. The tuning point will then be found fairly well up the condenser. It will probably be found, unless one is quite near to Brookmans Park, that the effect is too broad altogether on this tap. Try the next higher tap and carefully re-tune again. The tuning position will be at quite a different point farther down the dial, owing to the fact that we have used more inductance. The tuning, however, will be found to be distinctly sharper.

Continue in this way, working up the tappings, until the required amount of by-passing is obtained. The actual cutting-out will be found to get less as more inductance is included, but the tuning will be very much sharper, and on the top tapping the greatest care has to be exercised, for the tuning point will easily be passed.

I propose to discuss the operation of this by-pass further next week, and also to give details of an important additional feature. It is possible to use several of these by-

passes, all working together without any interference one between the other. This is of the greatest importance, for it is possible

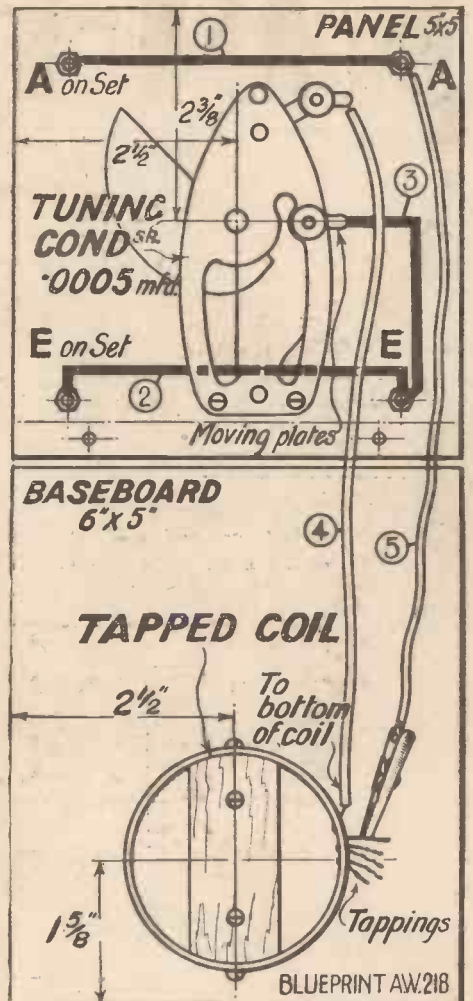

The wiring diagram. A full-size Blueprint is presented free with every copy of this issue

to arrange two units, one tuned to each of the Brookmans Park transmissions.

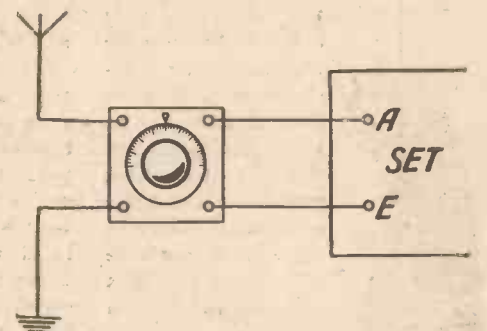

Fig. 3. Connections for the "By-pass"

Approximate tuning points for 356 metres (using Lissen .0005 condenser) are :

Tap No.	Dial Reading
1	125
2	85
3	60
4	45
5	25

# PURE LISSEN POWER

There is preserved power put into the big cells of the Lissen battery by the Lissen Secret Process—power which lasts for months and months and months, flowing always steadily, noiselessly, sustainedly. There is never a trace of ripple in it, never a sign of hum.

This Lissen Battery yields the purest form of current known for radio. It keeps speech clear, gives definition to musical notes and by the very purity of its current individual instruments seem "spot lighted" in the way they are made to stand out.

Next time ask firmly for a Lissen New Process Battery and take no other. Obtainable at 10,000 radio dealers.



**PRICES.**

60 volt (reads 66)	7/11
100 volt (reads 108)	12/11
120 volt .. ..	15/10
36 volt .. ..	4/3
60 volt (Super power)	13/6
100 volt (Super power)	22/-
9 volt Grid Bias	1/3
4 1/2 volt Pocket Battery	5d. each (4/6 a doz.)
Single Cell Torch Battery	4d.

**LISSEN LTD.,**  
WORPLE ROAD, ISLEWORTH, MIDDLESEX.  
Factories also at Richmond (Surrey) and Edmonton.  
(Managing Director: T. N. COLE.)

Don't Forget to Say That You Saw it in "A.W."

# My Wireless Den



Weekly Tips—Constructional and Theoretical—by W. JAMES

## Cutting Out Hum

**H**UM may be introduced into a set working off an alternating-current supply in such a variety of ways that it would be impossible to mention them all here.

An instance of bad hum that I came across only a few days ago, for example, was traced to the voltage of the filament supply not being correct. The valves were of the indirectly-heated type and should have been supplied with exactly 4 volts. Actually, the voltage was considerably less, and when this matter was rectified the set worked quietly.

This type of valve appears to need careful use. The manufacturers seem to emphasise the point that the filament voltage must be exactly 4, because, no doubt, if it is greater or smaller the results or working life are not up to standard.

There is one point I should like readers' views on, and that is how these valves behave when the supply is 25 or 33 cycles instead of the more usual 50. Do they work without hum?

## Wanted—Gang Condensers

I must confess to some surprise that British manufacturers seem not to tackle the problem of the production of good gang condensers suitable for amateur use. Some of those that I have examined are evidently simply two ordinary condensers, fitted together as an after-thought.

What I want is a really good two-gang condenser having a sturdy frame and plates that do not bend when accidentally touched.

Too many of our condensers are flimsy products, and, quite frankly, I cannot go ahead with designs until reliable products are available. The danger of short-circuits damaging valves can be guarded against, but the throwing out of the tuning cannot.

Some of the American condensers that I have seen are excellent products, and I know of no British ganged types to approach them.

## On or Off?

In looking over a number of commercial mains-driven sets lately I was struck by the absence of a visual indication that the current was on.

My own set has a flash-lamp bulb wired in parallel with the heaters of the A.C.

valves and is fixed behind a small coloured window. This seems to me quite a necessary fitment. Users having battery valves generally think of the accumulator and high-tension batteries and always remember to switch off. Those using the mains are quite liable to overlook the fact that the set is on, however, unless an indicator is fitted.

## "Overworked" Chokes

The choke condenser output filter circuit is largely used in modern receivers,

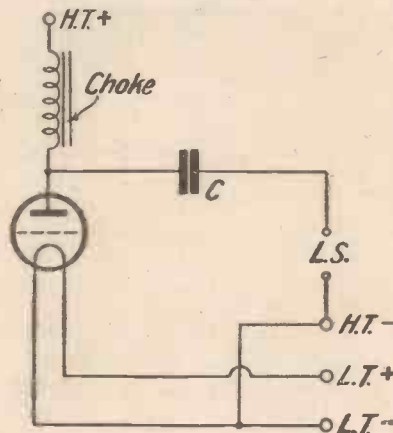

A normal output arrangement. Some interesting points about the possible saturation of the choke are raised by Mr. W. James

but I wonder how many amateurs could explain the advantages which are obtained from its use.

There is, of course, the obvious one that the high-tension current is prevented from passing through the windings of the loud-speaker by the condenser marked *c* in the accompanying diagram. This is a real advantage, for not only do a number of reproducers function better when no high-tension current passes through them, but the instrument is earthed on one side by its connection with L.T.—.

Perhaps the chief advantage, however, is that the varying currents representing the signal being received flow through the

condenser and loud-speaker. At least, they do when the inductance of the choke is high enough. Therefore, the tendency for low-frequency reaction troubles to produce distortion and motor-boating is minimised. Many a receiving outfit would distort very badly were it not for the output filter.

The choke must have adequate inductance under working conditions, or low notes will be lost. By this I mean that a proportion of the currents of lower frequency will pass through the choke. For the same reason, the capacity of the condenser should not be too small. Also, it should be of a type designed to withstand at least twice the normal working voltage.

## What About Your Former?

What sort of coil former do you use? Has it good electrical properties? Many a coil is less effective than it should be according to its size and the wire used, simply because the former upon which the wire is wound is defective.

There may actually be a leakage between the terminals of the coil fitted to the former, or perhaps the material is such that the high-frequency losses are heavy. Personally, I use paxolin. This, I know, expensive, but in my experience is very reliable. Ebonite is good, and so are some of the moulded formers, but not all. This point should receive attention, therefore, if you are interested in coils.

## Gramo-radio and A.C.

Curious results are sometimes experienced when a pick-up is connected to an alternating-current mains set, as a hum may be introduced, or noises made when the pick-up is touched.

I have in mind a set which was quite hum-free on wireless, but which produced hum and noise when a pick-up was connected in the usual way. The long leads to the pick-up seemed to be responsible for part of the trouble and also the relatively high impedance of the instrument.

Anyway, a grid leak of 100,000 ohms joined with short leads to the input to the valve cured the trouble so far as hum was concerned, and earthing the metal part of the pick-up stopped noises. Little points, such as these are apt to be overlooked, but I would suggest to anyone who is troubled that the grid leak and earthing tip be tried.

NEXT WEEK :  
THE  
HOME-CONSTRUCTOR'S  
LOUD-SPEAKER

# READY RADIO



# BEST-BY-BALLOT

AVAILABLE IN COMPLETE KITS OF PARTS

READY FOR IMMEDIATE DESPATCH

**PRICE LIST**  
of all the Correct Parts.

	£	s.	d.
1 Polished oak cabinet, 16 in. by 8 in. by 10 in., with baseboard	1	5	0
1 Resiston panel, ebonite, 16 in. by 8 in.	8	0	
2 Ebonite strips, 3 in. by 2 in. and 11 in. by 2 in.	1	9	
2 Ready Radio panel brackets	2	6	
2 Lotus variable condensers, .0005 microfarad.	11	6	
1 Lissen reaction condenser, .0001	4	6	
1 Ormond 15-ohm rheostat	2	0	
1 Clarostat volume control	7	6	
2 Push-pull on-off switches	2	6	
2 Brownie slow-motion dials	5	0	
2 Ready Radio dual-range coils—Q.A.T. and Q.S.G.	1	10	0
3 Spring valve holders	3	9	
1 Dubilier fixed condenser, .0002 (with series clip)	2	6	
1 T.C.C. fixed condenser, 1 microfarad	2	10	
1 T.C.C. fixed condenser, 2 microfarad	3	10	
1 Dubilier 2-megohm grid leak	2	6	
1 Ready Radio H.F. choke	6	6	
1 Igranite, type J, L.F. transformer, 6-1	17	6	
1 Lissen output choke	12	6	
3 Belling-Lee wander plugs, G.B.+ G.B.—1 and 2	1	0	
12 Belling-Lee terminals, type M	4	6	
1 Ready Radio partition screen	2	0	
1 Set valves (S.G., Det., Power)	2	5	6
20 ft. Glazite, screws and flex	1	7	
<b>INCLUSIVE TOTAL</b>	<b>£10</b>	<b>6</b>	<b>9</b>

Any of the above parts can be supplied separately if desired.

- KIT A** less valves and cabinet £6 16 3
- KIT B** with valves less cabinet £9 1 9
- KIT C** with valves and cabinet £10 6 9

**READY RADIO COIL**  
for the  
**BROOKMAN'S BY-PASS**  
Price 5/6 Complete

**READY RADIO IMMEDIATE DESPATCH SERVICE**

When you buy radio parts you naturally want them quickly. You also would be happier with the knowledge that in the event of subsequent difficulties you can obtain technical advice without trouble.

**TO HOME CUSTOMERS**

Your goods are despatched post free in sealed cartons or carriage paid by rail.

Note.—You can if you desire avail yourself of the C.O.D. system.

**TO OVERSEAS CUSTOMERS**

All your goods are very carefully packed for export and insured, all charges forward.

**EASY TERMS**

All Ready Radio Kits for the "Best-by-Ballot" can be obtained on our "No Deposit" terms if required.

- KIT A** 12 equal monthly payments of 12/6
- KIT B** 12 equal monthly payments of 16/9
- KIT C** 12 equal monthly payments of 19/-

**USE THE  
READY RADIO  
Q COIL**



**QAT 15/- QSG 15/-**

Telephone No.:  
Hop 5555  
Private Exchange.

# Ready Radio

Telegrams:  
Ready Hop 5555  
London.

159, BOROUGH HIGH STREET, LONDON BRIDGE, S.E.1

Mention of "Amateur Wireles" to Advertisers will Ensure Prompt Attention



**POMPEY the Great**, a play by John Masfield, will be broadcast from 5GB on February 6, and from 2LO and 5XX on the following evening.

The first of the 1930 national programmes to be transmitted by European stations on February 6 will be dedicated to France, Belgium, Czecho-Slovakia, Holland, Italy, and Poland will receive their tributes at regular intervals in the same series.

By special request, 5GB on February 12, and 2LO on the following day, will revive a broadcast of *Love in Greenwich Village*, the Gordon McConnel modernised version of Arne's *Love in a Village*.

It is expected that the first tests of the new Strasbourg P.T.T. high-power station will be carried out in March next on a wavelength of 345 metres. The actual transmitter is at Brumath, but the studio will be installed in the police headquarters at Strasbourg.

The new Rome high-power station was formally brought into operation on January 17 last. The transmitter is situated at Santa Palomba, at some fourteen miles from the Italian capital, and is eighteen times more powerful than the original plant it has replaced. The broadcasts are made on a wavelength of 441.8 metres, the transmitter being connected to the studio at Rome by pupinised cables.

On January 1 Germany exceeded the 3,000,000 mark in the number of licensed listeners; on that date her figure attained 3,066,682, an increase over the previous quarter of 223,113, or 7.8 per cent.

## SIGNALLING TO MARS

FROM considerations based upon the difference in gravity and of the ionisation of such gas as may be present on the surface of Mars, an American investigator has calculated that wireless waves of less than 100 metres cannot be used for signalling on the surface of Mars. Even for this wavelength the "skip" distance works out at some thousands of miles, whilst for shorter waves it is still greater.

On the other hand, waves of over 100 metres will not penetrate through the Heaviside layer surrounding the earth. Thus from both points of view there seems to be no hope of ever effecting wireless communication between the two planets, even assuming there are intelligent beings on our nearest neighbour in space. M. B.

Although the new Lemberg (Lwow, Poland) broadcasting station was to be brought into operation this month, difficulties which arose with the civic authorities have caused a postponement of the official opening. In the meantime, a provisional 1.5-kilowatt transmitter has been installed and will shortly work on 385 metres. The final plant destined to this city will be capable of radiating 10 kilowatts in the aerial, and will mainly relay the Warsaw programmes.

Through the Ste. Assise transmitter, the French Post Office authorities are carrying out a series of tests in short-wave telephony with a view to the establishment of a direct service between France, the United States,

## IN SEARCH OF SHARP TUNING ?

If you experience difficulty in separating one station from another, then you should fit a modern-type wavetrapp such as the "Brookman's By-pass" described this week, and of which we give a free blueprint. And next week will be described a three-valve incorporating the "Brookman's By-pass" unit. Make sure of your copy of this issue. Remember, the set is called the—

**"Brookman's By-pass 3"**

South America, and the Far East. A new system is being employed, and if successful will enable messages to be transmitted at a very reduced cost.

In July, 1929, a Royal Decree stipulated that the monopoly for establishing a broadcasting system in Spain was to be granted to the highest bidder. Tenders were put forward by various private associations, but the terms offered were so unsatisfactory that another auction is to take place next month. In the meantime the power of the existing station has been limited by law and, moreover, transmitting periods of the individual stations have been curtailed.

Paris listeners have decided that early morning "physical jerks" are uninteresting.

When the new Flemish broadcasting station, now operating on 339 metres, is definitely transferred to Velthem-Louvain (Belgium), Radio Belgique will install in the same building a new high-power transmitter for the French broadcasts. Both stations will increase their power to 15 kilowatts.

The French Ministry of Posts and Telegraphs proposes, at the cost of one-half million francs, to establish a special police radio service in France. The plan calls for over fifty separate short-wave receiving stations to be installed throughout the country, of which sixteen would be mobile, seventeen at frontier stations, and an equal number at the principal seaports. The key station of the system is installed in the Eiffel Tower, which by special cable is connected to the central police headquarters. By this means, communications may be immediately established with all districts in the country, as well as with flying squads of police attached to the French metropolis or other important provincial cities.

The B.B.C. announces that any member of the public who would like free tickets (admitting two) for the remaining B.B.C. concerts of contemporary music in the Central Hall, Westminster, should make immediate application to the Music Department, B.B.C., Savoy Hill, enclosing a stamped addressed envelope. The programme on March 3 includes music by John Ireland, Lambert and Walton; "Pierrot Lunaire," by Arnold Schonberg, is the chief attraction on April 7; and on May 5, Hermann Scherchen will conduct an orchestral concert.

Further details regarding the proposed high-power transmitter for Lille (France) are now available. The site of the station has been fixed at Camphin-en-Carembault, a village some eleven miles distant from the city, on the main road to Lens. Nothing less than the possession of a transmitter capable of radiating 12 to 15 kilowatts in the aerial will satisfy the Lille listeners.

The Soviet broadcasting system now disposes of sixty-three transmitters, and all stations, with the exception of Moscow Komintern, are operated by the Ministry of Posts and Telegraphs. With the exception of the latter there are no regular studio orchestras, the musical programmes being supplied by voluntary organisations.

## RADIO-FREQUENCY CURRENTS

ALTHOUGH we are taught that ohm's law holds as good at twenty-million cycles frequency as it does at 20 cycles, it is very difficult to give a practical demonstration of the truth of this statement. For one thing, the ordinary "thermo-couple" ammeter cannot be depended upon to give accurate readings at such high frequencies. For another the insertion of any type of measuring instrument in circuit is bound to introduce parallel capacity paths, which give rise, in turn, to an unknown amount of leakage.

In short-wave beam working, a small monitoring rectifier, in the shape of a five-watt tube with 100,000-ohms resistance in the plate circuit, is used to measure the radio frequency output. M. A. L.



*No other reproducer*  
 can give you such magnificent  
 fidelity, reality and purity of tone.  
 Listen to the fascinating rhythm of  
 dance music—the stentorious roar  
 of the crowd, the bewitching note  
 of the 'cello, or the human voice—  
 nothing is missed, nothing is exag-  
 gerated, you hear only the truth!  
 Hear it at your dealer's. Fully  
 descriptive literature sent free on  
 request.

Complete Speaker in  
 Cabinet

OAK - - - £4 : 0 : 0  
 MAHOGANY - £4 : 6 : 0

WATES STAR UNIT  
 12 poles. Double Magnets.  
 4 coils. Upper adjustment  
 for magnets, lower  
 for armature. ... 36/-

WATES STAR  
 Double Cone Chassis  
 (Patent No. 309214)  
 with brackets, specially  
 designed for use with  
 the Wates Star ... 12/-  
 Unit ... ..

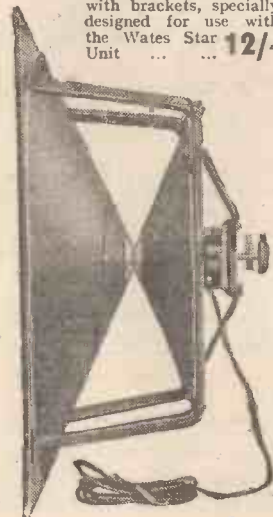
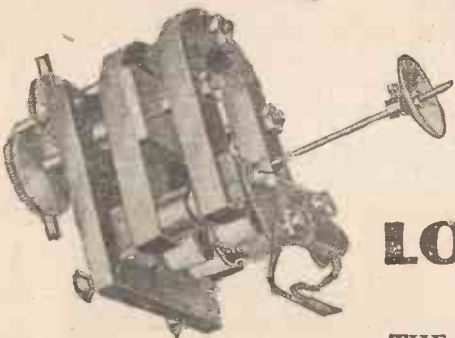

**WATES  
 STAR  
 LOUD SPEAKERS**

THE SHAFTESBURY RADIO CO. (Dept. A.W.)  
 184/188, Shaftesbury Avenue, LONDON, W.C.2

# OUR INFORMATION BUREAU



**RULES.**—Please write distinctly and keep to the point. We reply promptly by post. Please give all necessary details. Ask one question at a time to ensure a prompt reply, and please put sketches, layouts, diagrams, etc., on separate sheets containing your name and address: See announcement below. Address Queries—AMATEUR WIRELESS Information Bureau, 58/61 Fetter Lane, London, E.C.4.

## Using Different Speakers

**Q.**—I have been in the habit of using rather an old-type Amplion loud-speaker, but recently I have constructed a linen-diaphragm speaker using a Blue Spot unit. I find that when using the Amplion speaker my H.T. current consumption on the last valve was 10 milliamps. With the new speaker, the current consumption of the last valve increases to 16 milliamps. By using a Ferranti output transformer for either speaker individually the current consumption reads 14 milliamps. As this extra drain on the battery is rather disturbing, I should welcome any suggestions you may have to make on the subject.—F. D. (Bournemouth).

**A.**—When using a low-resistance speaker or one having a resistance of something less than 2,000 ohms, it follows that the voltage drop across the speaker windings is less than would be the case were a 2,000 ohms resistance speaker to be used. This means that actually there is more anode voltage applied to the actual anode of the last valve. If the grid bias voltage remains the same as before and the anode voltage is increased, then the anode current consumption of the last valve increases. The remedy is to increase the grid bias voltage applied to the last valve, or failing this, use a

choke-filter output circuit between the last valve and the loud-speaker. This latter suggestion is the one we suggest.—C. A.

## When Asking Technical Queries

**PLEASE write briefly**

A Fee of One Shilling (postal order or postage stamps) must accompany each question and also a stamped addressed envelope and the coupon which will be found on the last page. Rough sketches and circuit diagrams can be provided for the usual query fee. Any drawings submitted should be sent on a separate sheet of paper. Wiring plans and layouts cannot be supplied. Queries cannot be answered personally or by telephone.

## Separating the Regionals

**Q.**—I am having difficulty in separating the two transmissions of the new Brookmans Parks,

and in conference with a few radio friends, I find that my aerial being directional for the London station is causing some of the trouble. As I am unable to alter the direction of my aerial, and the use of a wavetrap does not materially assist in the elimination of interference, I wondered whether you could suggest a means of overcoming the trouble.—S. A. (Catford).

**A.**—There is really no need to have a directional aerial at all. If you will erect a vertical single wire aerial consisting of 7/22 copper wire and arrange the highest point to be as high as possible above surrounding house-tops and other screening objects you will not only improve the selectivity of your set, but you will cut out the objectional directional reception effect of your aerial system. At the same time we would suggest you attend to your earth. Use 7/22 copper wire also for the earth lead and solder this to a sheet of copper about 2 ft. square buried in an upright position, at least 3 ft. below the surface of the ground. This will make for a low-resistance earth connection. You will probably find now that you will eliminate interference between the two transmissions without the use of a wavetrap.—L. A.

# ALL ELECTRIC - 2

A SET WORTH LISTENING TO

£13



£13

The Igranic All Mains 2 operates entirely from A.C. Mains. Compact design. One knob control. Dual wave switch to eliminate coil changing. Perfect reproduction.



Supplied in attractively designed oak or mahogany table cabinet. Price £13.0.0 complete with valves and royalties.

Please state exact mains voltage when ordering.

Write to Dept. J.996 for details.



The

# Dix-onemeter

indicates the pinnacle of utility for electrical measurements.



50 ranges on one meter.

The Rolls-Royce of Radio Testers. Highest Grade at a low price. METER ONLY, 50/- RADIO SET, £4 10s.

Half the price of old-fashioned designs. Order one for 1930.

SAVES RADIO USERS POUNDS.

## ELECTRADIX RADIOS,

218, Upper Thames Street, London, E.C.4.

Blackfriars Station, Underground Railway.

Phone: City 0191.

## CURRENT

FOR YOUR

## MOVING-COIL SPEAKER

The comparatively heavy supply demanded by the pot magnets can be very easily obtained from your A.C. house mains with the aid of

A



## METAL RECTIFIER.

Full particulars, and circuits, showing how to use all types of Westinghouse Metal Rectifiers, are given in our 32-page book "The All-Metal Way, 1930." It includes a chapter of useful information on the running of moving-coil speakers from the mains.

Send 2d. stamp for a copy.

The Westinghouse Brake & Saxby Signal Co., Ltd., 82, York Road, King's Cross, London, N.1

# FERRANTI CONDENSERS



Type C1.



Type C2.

THE British workman is second to none in the world: British knowledge is second to none in the world: and British Condensers made by the British workman backed by British knowledge are second to none in the world. When the best that can be made are British made—at Hollinwood—it's just as well to stipulate

## Ferranti Condensers

and let your dealer understand that you know what's what!

### PRICES:

Type C1.....5/6      Type C2.....3/6  
Type C1T.....5/-      Type C2T.....3/-

\*Terminals for soldering only.

FERRANTI LTD.      HOLLINWOOD      LANCASHIRE

# THOSE MIDNIGHT JAUNTS

*Jottings from my Log—by Jay Coote*

**B**ECAUSE the home stations go off the air at midnight, one is not necessarily compelled to close down the wireless den, for after that hour, even on the broadcast band, on many nights there are interesting transmissions to be picked up. For instance, on Sundays, Tuesdays, and Thursdays, Madrid (EAJ7) may be relied upon for from thirty to forty-five minutes of dance music from one or other of the best hotels in the Spanish capital. On occasion, too, from that city you may hear an operatic or dramatic performance of which the transmission may be carried on until 1 a.m. or later. Copenhagen also, from time to time, relays a midnight cabaret from the New Theatre, a show which includes, as a rule, a large proportion of syncopated melodies.

## Late Germans

Then again, the German stations, according to a fixed rota, of which advance details are regularly given in these pages, broadcast a night entertainment, beginning at 11.30 p.m. G.M.T. When it is Hamburg's turn to entertain its local listeners in this manner, the Norag studio bridges the gap at the end of the usual evening programme by taking dips in the European ether.

Sometimes on Saturday nights Stuttgart at midnight starts a late transmission with a batch of the latest gramophone records, and with a view to pleasing the high-brows finishes up with short lectures in English, French, and Spanish, on such ponderous subjects as the German Chemical Industries, or an equally elevating talk!

Posen, too, must not be forgotten, as regularly on Saturdays it extends its broadcasts until 1 a.m. G.M.T. with a light popular orchestral programme.

## American Relays

For those who are not capable of reaching out to the United States, but desire to hear some of the American transmissions, Turin and Milan offer excellent opportunities if conditions are at all favourable. Regularly every Saturday evening at 11 p.m. G.M.T. *Radio Torino* makes an attempt to bridge the Herring Pond, and all catches are passed along for rebroadcast by Milan. On recent occasions, these experiments were prolonged until 1 a.m. and an excellent assortment of typical American programmes was offered to near and distant listeners.

At present, however, broadcasts from both American seaboard are being well

received, and a search on the lower broadcasting band after midnight will frequently bring its reward.

It will be worth your while to try for WPG (Atlantic City, N.J.) on 273 metres, and WIOD (Miami Beach, Fla.) on 242 metres. With the former you should find no difficulty, as no doubt you have already logged Kaiserslautern (a relay of Munich) and a slight twirl of the condenser should bring in the carrier wave of the world's playground (Atlantic City), if the Fates are at all kind. In the same way for Miami Beach (Wonderful Isle of Dreams) take the settings of Belfast or a trifle higher than those of Nürnberg which you must have heard at some time or other.

## Some Others

If in your log you possess the condenser readings of Hamburg or Bucharest, a short search around 395 metres may bring in WJZ (Bound Brook, N.J.), a high-power station of which the transmissions can be heard on this side under favourable conditions.

And lastly, do not forget our old friend WGY (Schenectady), whose position in the waveband is immediately under that of Radio Toulouse.



for the

## DUAL GANG CONDENSERS "1930 Ether Searcher"

J.B. Precision Condensers make all the difference to the selectivity of a Receiver.

The Dual Gang Condensers illustrated here have been specially designed for the "1930 Ether Searcher," and have the approval of the designers.

They are supplied assembled complete with J.B. Drum Dial, which makes accurate tuning a very simple matter.

No awkward assembly work is entailed—only two screws are necessary to fix the complete instrument firmly to the panel.

*Colvern panel and screen are made to suit this instrument.*

J.B. DRUM DIAL  
DUAL GANG CON-  
DENSER .0005  
TYPE E.S.

PRICE  
**29/6**  
COMPLETE



**PRECISION  
INSTRUMENTS**

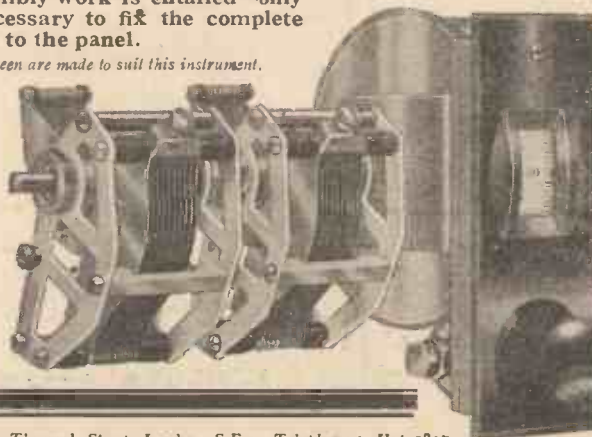

Advertisement of Jackson Bros., 72, St. Thomas' Street, London, S.E.1. Telephone: Hop 1837.

## "SILENT" TUNING

**S**ILENT tuning is a recent American innovation which has certain features of interest. A small milliammeter, located above the main tuning dial, indicates the point of maximum reception by means of a moving needle. Before changing-over from one station to another, a switch is depressed to disconnect the loud-speaker, so that the retuning operation is carried out in silence.

This prevents "blasting" by signals from intermediate stations between the one just left and the new programme desired. The approximate position of the new station is, of course, known on the main tuning dial, and the final adjustment is made with an eye on the indicator needle. Not until the needle swings to the correct position, is the loud-speaker again switched on.

B. A. R.

A dispatch from Capetown states that the Prince of Wales did not listen to the King's speech at the Naval Conference. At Wynberg, Capetown, the broadcast proved a failure. At Johannesburg the reception was very indistinct; Ramsay MacDonald's Scotch accent was recognised, but the King was not heard at all.

**AIRWAY WIRELESS**

By Thorne Baker, F.Inst.P.

WIRELESS is one of the most important means whereby aerial transport has become developed in recent years. Wireless telephones and wireless direction finders have solved innumerable difficulties in flight, and have, indeed, insured the remarkable freedom from accident which marks present-day aerial navigation.

It is less than twenty years ago since the writer sent the first wireless signals from an aeroplane in this country. A small, 2-in. induction coil spark set was used with a trailing aerial, on a bi-plane piloted by Mr. Robert Lorraine. Mr. Lorraine, the popular actor-airman, had just crossed by air from Ireland towards the English coast, when his machine dropped into the sea and he had to swim ashore. A day or two later he appeared at a London theatre in a play called *The Man From the Sea*. The trials were carried out during the Army manoeuvres on Salisbury Plain, and signals were received over a distance of about a mile and a half.

**A 250-mile Range**

To-day, as Mr. E. H. Furnival states in the Proceedings of the Institute of Radio Engineers, reliable working is required from ground to air and from air to ground up to distances of 100 to 150 miles, with the possibility of longer ranges being attainable up to a maximum of 250 miles when working with a main airport station.

While telephony is required for the European airways, continuous-wave telegraphy is used on Empire air routes. A telegraphic broadcasting service on another wavelength is provided for meteorological information.

Ground station receiving apparatus must be capable of directive reception, so that bearings can be taken, and by the co-ordination of a group of stations the position of an aeroplane or airship can be worked out and sent to it for its own information.

The civil airways of the United States use equipment the transmitter of which is rated at 2 kilowatts output, and is of the master-oscillator controlled type. A direct transmitting system, using crossed coil antennae, is used to guide aircraft over established airways. The pilot receives one signal while within a narrow zone just on the course, and other signals when he strays from the course. This has been found to facilitate flying very greatly when poor visibility conditions obtain.

Audiometer investigations at the Naval research laboratory at Anacostia have shown that the normal wireless operator is at least one-third deaf during flight, due to the effect of the noise on his hearing, which means that to obtain normal power of incoming speech the general aerial transmission must be increased correspondingly.



**KITS AND SETS**

**Our Test Room is Yours**

Every Pilot Kit contains a leaflet describing our special free Test Room Service available to all Pilot customers. Buy from the pioneer firm who guarantee good results.

**WE GUARANTEE YOU GOOD RESULTS**

**PILOT KITS INCLUDE:** All components approved by "Amateur Wireless," necessary coils, drilled panels and requisite connecting wire, screws, etc., and free Blueprint. "A" Kits also include the specified valves and the cabinet, whilst "B" Kits exclude these items.

**BEST-BY-BALLOT THREE**

A KIT. CASH PRICE £9 16 6 or 12 monthly instalments of 18/-.  
 B KIT. CASH PRICE £7 11 0 or 12 monthly instalments of 13/10.

**1930 ETHER SEARCHER**

A KIT. CASH PRICE £9 3 1 or 12 monthly instalments of 16/9.  
 B KIT. CASH PRICE £5 16 7 or 12 monthly instalments of 10/8.

Any parts supplied separately. Detailed lists on application.

Other "Amateur Wireless" sets available under the famous "PILOT" service include:

BRITISH BROADCAST TWO; NEW ALL-BRITAIN THREE; WORLD-WIDE SHORT-WAVE. Write for detailed lists.

**IMMEDIATE DELIVERY TO ALL APPROVED ORDERS**

**FINISHED INSTRUMENTS.** All the leading "A.W." sets including the above, are available as finished receivers, built in our own factory and aerial tested and guaranteed. Full details on application.

Qualified engineers are in attendance at all our Branches.



77 CITY ROAD, LONDON, E.C.1. Telephone: Clerkenwell 9406-7-8  
 62 HIGH HOLBORN, LONDON, W.C. Telephone: Chancery 8266  
 4 Manchester Street, Liverpool. Telephone: Central 2134  
 33 Whitelaw Road, Chorlton-Cum-Hardy, Manchester. Telephone: Chorlton-Cum-Hardy 2028

Mail coupon in unscaled envelope under 1d. stamp.

**THIS WEEK'S SPECIAL  
 BROOKMAN'S  
 BY-PASS**

Complete Kit, including ready-made coil as specified (4/6) ..... 12/6  
 with de luxe type coil, using plug and sockets for tappings, instead of twisted wire (5/6)..... 13/6  
 FINISHED UNIT with de luxe type coil..... 15/6



**COUPON.**

Please send me your 48-page Illustrated Catalogue, describing the 1929-30 products of all the leading makers.

NAME.....  
 ADDRESS.....

A.W. 1/2



**A FINE TUNING DEVICE**  
for your  
**EXISTING CONDENSER**

Fit a Lissen Slow Motion Dial to your existing condenser and get a new smoothness and ease of control in tuning. This Lissen Slow Motion Dial gives a handsome finish to any panel. In dustproof black moulded case; ratio 8 to 1; control knob rotates in same direction as dial; scale seen through window, with hair-line for accurate reading. Fits  $\frac{1}{4}$ " spindles, but can be adjusted for use, with spindles of any diameter up to  $\frac{1}{2}$ ". One extra hole only for fixing.

PRICE **3/6**

**LISSEN**

**VERNIER DIAL**

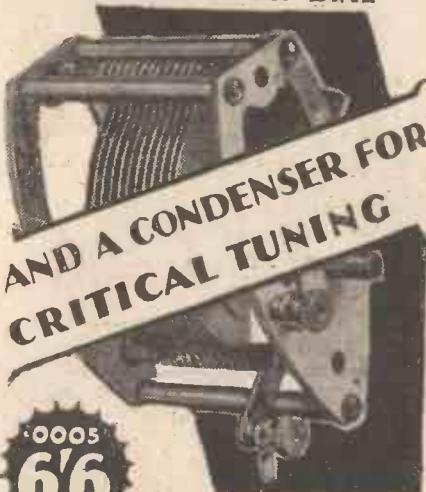

**AND A CONDENSER FOR CRITICAL TUNING**

**0005**  
**6/6**

- .0001 mfd. cap. 5/3
- .0002 mfd. cap. 6/-
- .0003 mfd. cap. 6/-
- .00035 mfd. cap. 6/3
- .0005 mfd. cap. 6/6

The new Lissen Variable Condenser enables you to enjoy a new standard of tuning—a new sense of smooth control—a new ease in separating stations close together—*simply because there is no condenser loss, and incoming signals are retained at full strength*

See the unmistakable rigidity of its construction; see the long bearing and the extended spindle for ganging purposes. Notice that there is no end pressure, no tendency to distortion of the vanes. The fixed vane terminal is in a new and convenient position well away from the end plates. There are feet for baseboard mounting, or standard one-hole-fixing for panel mounting

**LISSEN**  
**LOW LOSS**

**VARIABLE CONDENSER**

LISSEN LIMITED, Worples Road, Isleworth, Middlesex.

## Some Notes Regarding "Q" Coils

By J. H. REYNER, B.Sc., A.M.I.E.E.

THE new "Q" coils which were introduced at the beginning of this season have already proved a considerable advance on the earlier models. In particular, the switching difficulties seem to have been entirely overcome, for the only switch on the new model is of the simple push-pull variety in place of the rather more complicated series-parallel arrangement used in the earlier models. Added to which the coil is more efficient both on the long- and short-wave bands, and has at the same time, been made somewhat more compact in that it takes up less space on the baseboard, although its height is rather greater than before.

### The QAT

A certain amount of difficulty has been experienced with the new QAT (aerial) coil. The design of any dual-range aerial coil is a matter of great difficulty. If the coil is to have a coupled aerial winding, as is desirable for many reasons, certain limiting factors come into play. In the first place, the most important factor is that the selectivity must be good. This is all the more important in view of the regional transmissions of to-day, but it must be clearly understood that selectivity cannot be obtained on an aerial coil except at the expense of signal strength. There is nothing in the aerial circuit to compensate for the loss of energy occasioned by utilising a weaker coupling, and in arranging a reasonable measure of selectivity some sacrifice in signal strength has to be made.

A second important point is that care must be taken to prevent the short-wave local station from breaking through over the greater part of the long-wave scale. This is only too commonly found to be the case, and the aerial winding on the new QAT coil was very carefully arranged to avoid this as far as possible. Even comparatively close to a local station it will be found that the long waves are free from interference, except at the very bottom of the scale.

### Lack of Signal Strength

Those readers who live farther away from powerful transmitting stations may find that the signal strength is not adequate. In this case they should revert to the method adopted with the older type of "Q" aerial coil, namely, the connection of the aerial directly to the No. 1 terminal of the coil through a small pre-set condenser having a value of from .0005 to .0001.

As regards the H.F. transformers, both of the screen-grid and split-primary (neutralised) variety, the performance of these will be found to be comparable with a standard 6-pin coil. In fact, when these

(Continued on next page)



**DELIVERS ALL ITS STORED-UP ENERGY!**

**LISSEN**  
**GRID LEAKS**

These are resistances that never vary; they are absolutely silent in use, and their values remain unchanged. All values, each

**1/-**

With Terminals, 1/3 each.



When you buy a Lissen Fixed Condenser you can be sure that it will never leak, never vary in capacity, never break down in use, and will deliver all its stored up energy all the time.

For whatever purpose you require a fixed condenser—whatever circuit you are building, and no matter what is specified—use Lissen with absolute confidence. They are accurate to within 5% of stated capacity, and will remain constant throughout the life of the receiver. .0001 to .001, 1/-; .002 to .006, 1/6; .01, 2/-.

**LISSEN**

**FIXED CONDENSER**



**HOW TO BUILD UP FOR PURITY**

Lissen Resistance Capacity Coupling Unit embodies a .01 Lissen Fixed Condenser, which is leak proof and unvarying in capacity and which delivers all its stored-up energy. There is therefore no loss of volume, no loss of purity. The Lissen Fixed Resistances are silent; they never vary, no matter what the current load. Values incorporated have been selected as the most suitable for general use, but the resistances are easily interchangeable. May be mounted upright or flat.

PRICE **4/-**

**LISSEN**

**R.C.C. UNIT**

**LISSEN LIMITED**  
Worples Road, Isleworth, Middlesex



NOW YOU CAN USE AN ELIMINATOR JUST LIKE A BATTERY

27/6

D.C. MODEL "A" 100-110 or 230-250 v. Cash price 27/6, or 5/- down and 5 monthly payments of 5/6.  
 D.C. MODEL "B" 100-110 or 230-250 v. Cash price 39/8, or 5/- down and 8 monthly payments of 5/-.  
 A.C. MODEL "A" 100-110, 230-210, 220-230, 240-250 v. Cash price 60/-, or 5/- down and 10 monthly payments of 6/6.  
 A.C. MODEL "B" 100-110, 230-210, 220-230, 240-250 v. Cash price 75/-, or 5/- down and 10 monthly payments of 8/-.

Lissen H.T. Eliminators deliver smooth steady current from your house electric supply, and cheaply. The Lissen Eliminators can be put into your set as easily as any battery. From the four types made there will be one to suit you. Send a deposit of 5/- and we will arrange for delivery of the Eliminator to suit you and for it to be properly installed. Send 5/- only. Leave the rest to us. You pay the balance in one sum after installation or by extended instalments.

**LISSEN**  
ELIMINATORS

LISSEN'S NEW 5-PIN VALVE-HOLDER suits all valves!

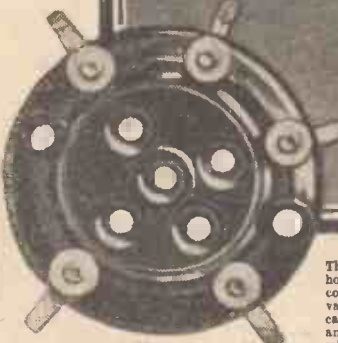

The latest in valve-holder design and construction. Recent valve developments call for 5-pin valves, and this tendency will without doubt be extended. Save expense by fitting 5-pin holders NOW. Exceptionally strong, with springs entirely independent and cannot short-circuit. A glove-like fit to any standard valve, with positive terminal connection to valve pins. IN BROWN MOULDED CASE

**LISSEN**  
FIVE-PIN  
VALVE-HOLDER

LISSEN LIMITED, Worples Road, Isleworth, Middlesex

**"SOME NOTES REGARDING 'Q' COILS"** (Continued from preceding page)

coils were designed comparative measurements were taken and a good deal of experimental work was done to ensure that the high-frequency amplification of a valve followed by a "Q" coil should be within a few per cent. of that obtained with a standard 6-pin coil designed to operate on only one wave band.

It was not found practicable to equal the performance on both wave bands, but it was ultimately possible to get within a very small amount, the difference being indistinguishable by ear and only shown upon actual measurements. This in itself is a considerable achievement and indicates that the use of the dual-tuning properties does not seriously detract from the efficiency of the "Q" coil.

**THREE-METRE WAVES**

AS the result of recent experiments, Alexanderson has succeeded in signalling over a distance of 3,000 miles, using a wavelength of only 3 metres. It is a curious fact that he could only cover this distance in a North-South direction, the corresponding range in an East-West direction being comparatively short. It is thought that the difference in working range is due to the prevailing direction of the earth's magnetic field.

The real difficulty in the use of such short waves in practice is their persistent tendency to "fade." There is a fortune waiting for the first inventor who finds the remedy.

M. A. L.

**RADIO ACROSS A CONTINENT**

THERE has been carried on in Canada an enormous expansion of simultaneous broadcasting. The Canadian National Railways, which "runs" radio in Canada, began with a pioneer link between Montreal and Ottawa, a distance of 116 miles, later adding Toronto, which required 334 miles of wire along the base of the triangle. In turn were added Quebec, then Winnipeg, Moncton, and London, with posts even in the prairie provinces!

Now it is announced that Vancouver has been included as the western terminus of the radio chain. As a result, sixteen stations are now available for simultaneous broadcasting from Atlantic to Pacific.

What this means will be realised when it is understood that the physical wires of the Canadian National Telegraphs follow the line of railway 653 miles from Moncton, N.B., to Montreal, Que., then 2,944 miles from Montreal to Vancouver, B.C., a total wire mileage of 3,597 being thus necessary.

It must also be understood that the instantaneous impulse of the current traverses five time zones, each an hour apart, a matter requiring serious study when planning a programme. In this, Canada has the distinction of possessing the only complete wireless broadcast "hook-up" in the world to serve so many differing clocks.

**HAVE YOU HEARD**

The **LISSEN** ADJUSTABLE

**BALANCED ARMATURE SPEAKER**

WITH MOVING COIL TONE!



COMPLETE ASSEMBLY 22/6

The Lissen 4-Pole Balanced Armature Unit brings something approaching loud-speaker perfection within the reach of everybody who owns a radio set. You can build any type of cone loudspeaker with it; you can use it with a big baffle board, or put it in a cabinet. You can build a linen diaphragm loud-speaker with it, or you can buy it completely assembled and ready to connect up to your set. It has a fine adjustment, and you therefore get the utmost volume from it without chatter.

In brown moulded case with attachment for fitting to any type of cone. PRICE 12/6

Cast aluminium Chassis, specially designed to give the best results from the Unit. PRICE 7/6

13 in. Cone for use with the above, 2/6.

**LISSEN** ADJUSTABLE  
**BALANCED ARMATURE UNIT**

**SWITCHES** for EVERY PURPOSE!



- PRICES :**  
 Filament Switch, 1/-  
 3 Point Wave Change Switch, 1/6  
 2 way Switch, 1/6  
 5 Point Switch, 2/6  
 D.P.D.T. Switch, 2/6

There is a Lissen Switch for every radio switching purpose. All Lissen Switches are fitted with terminals for convenience in wiring, and all contacts are positive and self-cleaning. Whatever purpose you want a switch for, consider value for money and you will decide upon these low-loss Lissen Switches.

**LISSEN**  
**SWITCHES**

LISSEN LTD., Worples Road, Isleworth, Mid. I. sex.

H & B IT'S GREAT! "The Best-by-Ballot 3"

Success assured with H. & B. Kit

Table listing components of the H. & B. kit such as Ebonite panel, variable condensers, reaction condenser, rheostat, volume control, push-pull switches, slow-motion dials, dual-range coils, valve holders, etc., with their respective prices.

Baseboard, wire, screws supplied with all kits. Panel and Strips ready drilled. Mullard or Cossor valves, 45/- extra. Hand-polished cabinet, 17/6 extra.

We are demonstrating this set in our showrooms for one week only, 10-30 a.m. to 6-30 p.m.

BEST-BY-BALLOT 3. Supplied on the H. & B. Gradual Payments System 18/- down and 10 monthly payments of 12/6. Kit, with Valves, 38/6 down, and 10 monthly payments of 15/6.

BROOKMAN'S BY-PASS Complete kit of components to construct this By-Pass can be supplied at a low cost of 12/-, post free. Supplied ready constructed, 15/-.

BUY THE H. & B. WAY. NO REFERENCES. IT'S EASIER. IT'S BETTER STRICTLY CONFIDENTIAL.

Harlie Gramophone Pick-up, complete with tone-arm and volume control. Cash price £1 17 0, or 8/- down and 4 monthly payments of 8/-.

Harlie Moving-coil Speaker. Perfect tone; amazing volume. Write for details and leaflet. 6-volt accumulator model £3 10 0, or 10/- down and 7 monthly payments of 10/-.

Celestion Model C Oak Cabinet Speaker, 10-in. reinforced diaphragm. Cash price £3 15 0, or 10/6 down and 7 monthly payments of 10/-.

Regentone Eliminator. A.C. model WIB S/G. 1 variable 0-120 S.G., 1 variable 0-120, 1 fixed 130/150 tappings. Cash price £4 19 6, or 10/- down and 11 monthly payments of 9/-.

Wates Star Speaker Unit and Double Cone, with Chassis. Cash price 48/-, or 10/- down and 4 monthly payments of 10/-.

Ormond 1930 Cone Speaker, in Oak Cabinet. Cash price 29/6, or 8/- down and 4 monthly payments of 6/-.

B.T.H. Pick-up and Tone Arm. Cash price 45/-, or 6/- down and 7 monthly payments of 6/-.

Osram 1930 Music Magnet. Complete kit, with 3 Valves and Oak Cabinet. Full instructions included. Cash price £9, or £1 down and 10 monthly payments of 17/6.

Cossor 1930 Battery Kit, complete with Cabinet, Valves and full instructions. Cash price, £8 15 0, or 16/- down and 11 monthly payments of 15 10.

Ekco A.C. Eliminator. 3.F20, S.G., 60-120, 120/150. 10/- down and 8 monthly payments of 9/8.

Philips 1930 Cone Speaker. Cash price 50/-, or 10/- down and 8 monthly payments of 7/6.

Brown's Vee Unit and Chassis. 8/7 down and 4 monthly payments of 8/7.

Carriage paid on all orders. We can supply anything Radio. H. & B. RADIO Co. 34, 36, 38 Beak Street, Regent Street, London. W.1 Phone: Gerrard 2834

BROADCAST TELEPHONY

Broadcasting stations classified by country and in order of wavelengths: For the purpose of better comparison, the power indicated is aerial energy.

Main table of broadcast stations with columns for Metres, Kilo-cycles, Station and Call Sign, Power (Kw.), and Country. Countries listed include GREAT BRITAIN, AUSTRIA, BELGIUM, CZECHOSLOVAKIA, DENMARK, ESTHONIA, FINLAND, FRANCE, ICELAND, HUNGARY, IRELAND, ITALY, GERMANY, POLAND, ROUMANIA, RUSSIA, SPAIN, SWITZERLAND, and TURKEY.

CHIEF EVENTS OF THE WEEK

- LONDON AND DAVENTRY (5XX) Feb. 3 Concert relayed from Frankfurt. Feb. 4 Vaudeville programme. Feb. 5 Symphony concert relayed from Queen's Hall. Feb. 6 French national programme. Feb. 7 Warren Hastings, a play by Feuchtwanger. Feb. 8 Running commentary on Arsenal v. Everton football match, relayed from Highbury. DAVENTRY EXPERIMENTAL (5GB) Feb. 5 Vaudeville programme. Feb. 6 Warren Hastings, a play by Feuchtwanger. Feb. 7 "Sax-Appeal," a Saga of Syncoption. Feb. 8 Witch Wife, a drama by Michael Hogan and Mabel Constanduros; and The Crossing, a play by Holt Marvell and Cyril Lister. GLASGOW Feb. 2 Reid orchestral concert, relayed from Edinburgh.

- BELFAST Feb. 4 You're Through, a radiophonic revue, by Charlie Brewer. Feb. 8 Running commentary on Rugby International football match, Ireland v. England, relayed from Dublin.

A new development in connection with broadcast plays is now on foot. The B.B.C. has in mind plans for forming a dramatic repertory company of its own. This will be made up of well-known artistes, and will specialise in radio plays and gramophone recording.

The Latvian Government has decided to erect a high-power station in the neighbourhood of Riga and to leave the present transmitter as a relay for that city only.

All wavelengths marked with an asterisk have been allotted according to the Plan de Prague.

**MORE RADIOGRAMS**

CANADA now has 81 broadcasting stations, of which 13 belong to the Canadian National Railways, 15 to radio dealers, 13 to newspapers, and the rest are divided in smaller numbers among other industries. The average power per station is 500 watts.

According to reports received from Russia, the new 100-kilowatt Moscow transmitter which was recently installed at Schtschelkov, some twenty-four miles distant from the capital, is to see its power increased threefold in the near future. At present it may be heard working nightly on 938 metres with relays of outside broadcasts or musical programmes from Leningrad. In the later hours, it transmits a news bulletin, as did Moscow Komintern. It is now proposed to extend its activities in propaganda to other neighbouring countries, and already talks in the German language are being given every Saturday evening from 7.30 p.m. onwards. Both from Moscow and Leningrad broadcasts are now made in English, French, German and Italian.

All applications for broadcast receiving licences lodged by Danish listeners must be accompanied by an expression of opinion on the transmissions made by the official stations and by suggestions of programmes likely to be of general interest.

An interesting departure by the B.B.C. in the series of broadcasts for Scottish schools will be entitled, "The Men of Old: Figures from Scotland's Past." The series will deal with Scottish history from the War of Independence to the Reformation.

**NEXT WEEK:**

**TWO VERY SPECIAL FEATURES:  
"THE BROOKMAN'S BY-PASS 3"  
AND THE HOME-CONSTRUCTOR'S  
LOUD-SPEAKER**

A hundred per cent. Scottish radio revue is promised for January 28. It is entitled, "What's Right With Scotland?" and is said to be based on the recent talks on "What's Wrong With Scotland."

The B.B.C. testing vans have now reached the Falkirk-Larbert area in connection with the search for a central broadcasting site for all Scotland. The experiments are expected to last several weeks, but it is fully anticipated that the station will ultimately be erected in the locality now being tested. The site selected will probably cover about thirty acres, with three or four masts of a height of about 500 ft., and a year is spoken of as the time required for construction of the station. It is understood that the executive offices of the B.B.C. in Scottish centres will remain as at present, and that the existing city studios will continue to be used, being linked in the usual way with the regional transmitter at Falkirk.

**GET PENTODE VOLUME FROM BATTERY POWER**

**AMPLIFICATION FACTOR 90**

**AMPLIFICATION FACTOR 90**

**AMPLIFICATION FACTOR 90**

**USE THE NEW LISSEN POWER PENTODE VALVE FOR L.F. AMPLIFICATION**

**LISSENS NEW POWER PENTODE BATTERY DRIVEN 176**

PT 225

The new conception in valve design. The big volume valve yet working off dry batteries. Giving tremendous volume from small incoming signals—with purity. Any set with one stage of L.F. amplification is vastly improved by the new Lissen Power Pentode. No alteration of wiring necessary. Put it in the L.F. stage (its amplification is so great that it is not recommended when there are two L.F. stages in any set). It takes only 7 milliamps of current, therefore imposes no heavier drain on your batteries than any ordinary L.F. valve, yet gives tremendous volume.

Instead of buying a Power Valve, next time buy one of the new Lissen Power Pentode Valves—it will improve your set out of all recognition. It goes straight into your set without alteration.

**Other Types and Prices**

H.210 R.C. and H.F., 10/6  
H.L.210 General Purpose, 10/6.  
L.210 L.F. Amplifier first stage, 10/6. P.220 Power Valve, 12/6.

**LISSEN LTD.** WORPLE ROAD, ISLEWORTH, MIDDLESEX. Factories also at Richmond (Surrey) and Edmonton.  
(Managing Director: T. N. COLE).

**BUILD YOUR KIT INTO**



Takes any set having panel up to 18 in. x 8 in.

**This Magnificent VOXKIT CONSOLE**

Hold both Speaker and Set!

Combines this advantage with unusually attractive appearance. Handsome overlays are supplied to suit almost any receiver. With or without speaker. Attractive art brown silk is fitted in either case. When ordering, specify type of set you propose fitting into cabinet. The speaker is the famous ULTRA Double Lined Diaphragm Air Chrome type K. Chassis, giving superb results at all frequencies.

PRICES:

WITH SPEAKER, Oak	£6 17 6
Mahogany	£7 7 0
WITHOUT SPEAKER, Oak	£4 4 0
Mahogany	£4 13 6

Stockists all over England. Write for full details and name of nearest stockist to:

**THE BRITISH RADIO GRAMOPHONE CO., LTD.**  
77 CITY ROAD, LONDON, E.C.1.

# LETTERS TO THE EDITOR



The Editor does not necessarily agree with the views expressed by correspondents.

Correspondence should be brief and to the point and written on one side of the paper.

## The "James Special Three"

SIR,—I built my set, the "James Special Three," as soon as it came out. Reading every week the praises of your other readers for your various sets, I felt I had to put a word in for this set.

With regard to range and power, I get fifty-five stations at good loud-speaker strength.

The set is exactly as described, except for two wavetraps (I live so close to Brookmans Park), a semi-variable condenser in the aerial lead instead of a fixed, and a .0002 condenser across the transformer primary. The quality is excellent, and I must congratulate Mr. James on such a set.

D. (Hampstead).

## Licence Costs

SIR,—Your correspondent P.D. (Towcester) says he "would not mind the job of issuing licences at even a farthing each," and exclaims: "Just work this out." I have, and apparently P.D. would issue one licence every minute of a twelve-hour day, every day (including Sundays) for over eleven years, without cessation for meals, etc.; and his princely remuneration would be, taking his figure of £3,000, under £273 per annum, with which he would show a fair profit after allowing for reasonable cost of printing and clerical work.

Has he not overlooked the many consequential expenses incurred beyond the mere writing out of the licence form? How would he cover the cost of rent, lighting, heating, cost of conveyance of, and checking and accounting of counterparts, dispatch and accounting of cash, compiling statistics to enable the P.M.G. to reply to questions in the House, which are often built on as chimerical a basis as P.D.'s "farthingsworth" of labour?

Does he realise that the work is done at many hundreds of offices in Great Britain, and that the correspondence involved can be no small item, even ignoring the three million postcard reminders sent out during the year?

W. B. (Hockley).

## Why?

SIR,—Some time ago I was desirous of building a certain set, but previous experience having taught me to delay the other parts until I had obtained the key component, I requested my dealer to obtain this. At the end of the third week the same old tale, "Sorry, sir, but it hasn't come through yet," caused me to cancel

the order. In another case I required a British-made cone chassis. This order was given to another dealer, who at the time had a choice of foreign products, and at the end of four weeks' time this British chassis had not arrived. In both these cases the retail dealer was entirely blameless.

A friend of mine, whom one could term "a constructive radio fan," having had several similar rebuffs, eventually fell to the lure of an intensive trade campaign, which is at present being pushed by an enterprising foreign firm, and has had one of their sets installed which is giving him every satisfaction.

This means no more experimenting, and no more disappointments over radio components, with the consequent loss of trade to British manufacturers whose dilatory marketing methods are resulting in our home goods being pushed to the wall to make way for reliable foreign radio products.

Unlike the B.B.C., radio manufacturers cannot force upon the public that which is not required, and they should clearly understand that the purchaser, who wants value for money, must be catered for with push and go and prompt attention to orders.

W. T. (Coventry).

## Gramo-radio and Record Wear

SIR,—With reference to the final paragraph of your recent article entitled "Hints for the Gramo-radio Enthusiast," we would like to bring before your notice the fact that one of the claims made for the Burndept needle armature pick-up is that of absolute minimum wear upon the record.

This is brought about by the extremely small dimensions of the moving parts, which consist only of the needle holder and the needle screw, the needle itself forming an integral part of the pick-up, namely, the armature. Damping, as such, does not exist, for the pick-up is built on an entirely new principle, and we have made tests of prolonged playing on single records to determine the amount of wear which takes place, and we can state quite definitely that the amount of record wear visible after these prolonged tests is almost negligible.

Furthermore, we notice that in the same article certain needles are specified for our pick-up, but you do not state which type of pick-up this is. We market

(Continued on next page)

# PERFECTION!

## The "GRAWOR"

4-POLE BALANCED ARMATURE UNIT

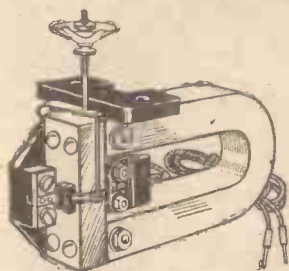

Every atom of energy fed to this Grawor Unit is handled in a masterly manner.

**21/-**  
From all Dealers.

# GRAWOR

Sound - in Every Sense

## HENRY JOSEPH



11 REDLIONS SQ.  
HOLBORN  
LONDON, W.C.1

Telephone:  
CHANCERY 8770

SEND POSTCARD  
FOR THE GRAWOR  
ILLUSTRATED  
PRICE LIST.

GRAWOR





**2/6**  
**THE DOMINION**  
**VERNIER**  
**DIAL**

Only Brownie's huge production enables them to offer this really splendid dial for 2/6. The special non-backlash design makes hair-breadth tuning a matter of delightful ease, while its handsome appearance (black or beautifully grained mahogany bakelite) will add to the good looks of that new set you are building.

BROWNIE WIRELESS COMPANY (G.B.) LIMITED,  
NELSON STREET WORKS, LONDON, N.W.1.

**BROWNIE**  
**WIRELESS**

**Follow the lead**  
**of the Experts**



ANODE

**Use**  
**TUNEWELL COILS**

Tunewell Coils have been specified for many sets famous for their reception. For selectivity and stability over the whole range, Tunewell Dual Range Coils cannot be beaten.

Coil illustrated, for Reinartz, Hartley, S.G. or Mains Circuits

**10/6 each**

For Mullard S.G.P.3, Clarion S.G.3, Cossor S.G.3, Dominion 4, etc.  
**10/6 each (Aerial or Anode)**

2-pin Coils, all types .. from 1/6  
6-pin Coils, most types .. from 3/11

**TURNER & CO.**

**54 Station Road, London, N.11**

**LETTERS TO THE EDITOR**

(Continued from preceding page)

two distinct types, namely, that which was first placed on the market and known as the Burndept Electric Soundbox, in which almost any needle may be used, but for preference the H.M.V. half-tone needle is recommended, and the new type needle armature pick-up in which the following needles only can be used: Columbia De Luxe, Ideal, or Spearpoint. It is possible to make use of any of the H.M.V. Tungstyle needles, provided that these are not pushed right home.

BURNDIPT WIRELESS (1928), LTD.

**Appreciation**

**S**IR,—Just a line to you and your paper thanking you for the topping "20 Sets and Speakers." Your paper is the goods and then some (as the Yanks say).

I'm also thanking you for that top-hole short-wave adaptor (AMATEUR WIRELESS, 183). I've been working it for weeks now, and I think it's the best I've had yet, being simple and easy to control. With this adaptor I can get amateur stations all over Great Britain and sometimes Europe. The French amateur stations come in very strong at times. This is January 19, Sunday, so you can guess I've had a real good scout round for short wavelets.

H. (Bradford).

**FOR THE "1930 ETHER SEARCHER"**

**C**ONSTRUCTORS of the "1930 Ether Searcher" will be interested to know that Jackson Bros. are now marketing their standard drum-dial-operated dual condenser to fit this receiver. Colvern Radio have arranged for the immediate supply of

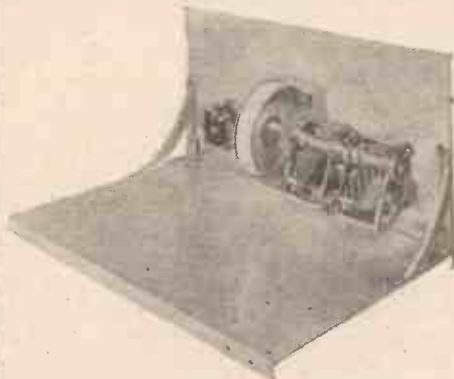

J.B. condensers in the "1930 Ether Searcher"

a special metal panel suitably drilled to take the Jackson condenser.

The joint designers of the "1930 Ether Searcher" are impressed with the simplicity of the mounting of the Jackson condenser. Only two bolts are needed to mount the complete condenser and drum-dial assembly. The photograph shows the Jackson condenser fitted to a Colvern panel.

**The Easy Way**  
**TO PERFECT RADIO**

In addition to their own extensive range, PETO SCOTT offer YOU Every Known Radio Receiver or Component on

**EASY TERMS**  
with  
**SERVICE AFTER SALES**

The following list is merely representative, and we ask you to fill in the coupon below or send us a list of your requirements.

OSRAM MUSIC MAGNET. Cash £9, or 12 monthly payments of 16/6 Valves included.

COSSOR 1930 THREE-VALVE KIT. Cash £8 15s., or 12 monthly payments of 16/6.

EXIDE 120-VOLT H.T. ACCUMULATOR, Type W.J., 2,500 m/a. In Crates. Cash £3 15s., or 12 monthly payments of 6/11. Type W.H., 120 volts, 5,000 m/a. In Crates. Cash, £4 13s., or 12 monthly payments of 8/6.

REGENTONE W.L.B. S.G. (A.C. Mains). For S.G. and Pentode Sets. Cash £4 19s. 6d., or 12 monthly payments of 9/2.

CELESTION C.12 LOUD-SPEAKER, in oak. Cash £5 12s. 6d., or send only 10/4, balance in 11 monthly payments of 10/4; in Mahogany, Cash £5 17s. 6d., or 12 monthly payments of 10/9.

**SPECIAL OFFER**

Double-linen diaphragm Air Chrome speakers in oak or mahogany table model cabinets of handsome appearance. These speakers have been specially made for us and the cabinets are so designed that they ensure the utmost purity and depth of tone from the ULTRA type K chassis which is incorporated.

**SPECIAL PRICE £4 : 4 : 0**

or send only 7/6 and balance by 11 monthly instalments of 7/6.

STANDARD WET H.T. 144-volt battery 10,000 m/a absolutely complete. Cash £4, or 12 monthly payments of 7/4. All parts for these batteries available.

**PETO SCOTT CO., LTD.**

Free Demonstrations and advice by Qualified Engineers at our Shops:—

77 CITY ROAD, LONDON, E.C.1

Telephone: Clerkenwell 9406-7-8.

62 HIGH HOLBORN, LONDON, W.C.1

Telephone: Chancery 3236

4 Manchester Street, Liverpool.

Telephone: Central 2134.

33 Whitelaw Road, Chorlton-cum-Hardy, Manchester.

Telephone: Chorlton-cum-Hardy 2028.

Mail coupon in unsealed envelope under 1d. stamp.

**COUPON**

Please send me your 48-page Illustrated Catalogue, describing the 1929-30 products of all the leading makers.

NAME .....

ADDRESS .....

A.W.1/2

**EVERYMAN'S**  
**WIRELESS**

By Ernest H. Robinson (5 Y.M.)

A handy book telling in plain, non-technical language all that the average man needs to know about Wireless.

**CASELL'S**

**3/6 net**

**THE LETTS' 1930 AMATEUR WIRELESS NOTEBOOK DIARY**

**1/6**

88-page Reference Section Full of Useful Data

**2/6**

**SATISFIED?**

Are you satisfied with the results of your Set? If not, why not reconstruct or build a new set?

**EVERYTHING WIRELESS**  
on  
**EASY TERMS**

Brookman's By-Pass, Mullard Orgols, Cossor Melody Maker, Climax H.T. Units, and all components.

Cut out interference with the **WATMEL WAVE TRAP**. Price 8/6 post free by return.

Call or send list of requirements.

QUOTATIONS OF OUR best monthly terms by return of post. Catalogue on request.

**The P.D.P. Co., Ltd. (Dept. A.W.)**  
121, CHEAPSIDE, LONDON, E.C.2.  
Telephone: National 9846.

**INSIST UPON SOVEREIGN ALWAYS BETTER**

THE Sovereign Compression-Type Condenser maintains the Sovereign standard—always better. Suitable for use in The Brookman's Rejector, The Wavechange Rejector, The Kendall Rejector, etc. etc. In standard size Bakelite moulding. Best Ruby Mica, Nickel-silver plates. From all d.dealers. If any difficulty send to us direct. Requirements by return. 2/-

Tube F1 .0001 mfd.  
Type G2 .001 mfd.  
Type J3 .0003 mfd.



Produced by J.R. WIRELESS CO.  
6-8, Rosebery Avenue, London, E.C.1

Baldry Ad. J.R.11.

**SUPER-MICROPHONES**

New, highly sensitive, made on the latest principle, a vast improvement over all other types: will pick up whispered words from a distance of several yards, also strongly amplify and transmit speech and music over a distance, through Loud-speaker or Headphones. Splendid instruments for making Detectaphone, DEAF-AID, LOUD-SPEAKING TELEPHONE, Announcements through Loud-speaker, Amplifier for Crystal or Valve Sets, Electric Sound Detector, BABY ALARM or INVALID

CALL from bedroom through distant Loud-speaker, Experiments, etc.

NO OTHER MICROPHONE OF EQUAL SENSITIVENESS KNOWN: each instrument finely black enamelled and fitted with a 3 ft. silk connecting cord. Despatched by return post. 8/6

**SPECIAL MICROPHONE TRANSFORMER** for connecting Super-Microphone to Radio Headphones, Loud-speaker, Valve Set, or Valve Amplifier 6/-

**SMALL 10 OHMS EARPIECE** for use with Super-microphone as a HIGHLY EFFICIENT DEAF AID, or Detectaphone, etc.: thin 3-ft. silk connecting cord fitted. Earpiece finely black enamelled. 6/-

Full Directions for use of Super-Microphone for many purposes and Diagrams of connections free.

FREDK. ADOLPH, Actual Maker, Phone: 27, Fitzroy Street, London, W.1. MUSEUM 8329

**THE WANDER PLUG WITH THE POWERFUL GRIP**

Look at its prongs of special spring-metal that grip the sockets—its insulated holder—the neat engravings on the head—its finish. Replace your old wander plugs with Belling-Lee to-day, and put an end to bad contacts and loose plugs.

Ask your dealer, or send to us for Belling-Lee Handbook, "Radio Connections."



4d.

P. Pat.

**BELLING-LEE**  
FOR EVERY RADIO CONNECTION

Advertisement of Belling and Lee, Ltd., Queensway Works, Ponders End, Middlesex.

**"TRANSFORMER BUILDING AT HOME"**

(Continued from page 176)

We have now considered how the correct number of turns for the primary coil is arrived at to suit any supply voltage, frequency, and size of core. The next point to receive attention should be the voltage and current required in the secondary circuit. Let us suppose we want to heat four valves of the indirectly-heated cathode type, taking one ampere each at 4 volts. Then the total current is 4 amperes.

We must, of course, allow a little for the resistance of the wire in the transformer, and to be on the safe side it would be as well to provide a tap. Suppose, then, that we reckon on 4.5 volts as the no-load voltage and make a tap at 4.25 volts, so that, according to the actual voltage of the supply and the current taken by the valves, there is a little margin for adjustment.

The number of turns is found by multiplying the voltage by 8, from which we obtain 36 turns with a tap at the 34th turn. As this winding has to carry 4 amperes, No. 16 wire should be used, and the covering may be enamel or cotton.

This wire is rather heavy, but, as there are few turns, winding is not difficult. Having decided on the secondary coil, we may estimate the current which will flow in the primary quite easily. If the supply voltage is 200, for instance, the ratio of the transformer is 200:4.5—say, 45 to 1. Thus the current taken from the mains will be one forty-fifth of 4 amperes, plus that due to the losses and the magnetising current—or, say, .15 ampere.

**The Primary Winding**

For the primary coil, therefore, No. 28 wire will be suitable. The next question is whether the correct number of turns may be put in the space available after allowing room for insulation and bobbins. This can be found by estimating the amount of space taken by the wire itself, using the wire tables and allowing further space for the bobbins.

If there is room, the work of construction may be commenced, but should there be too little room, the design will have to be altered. A larger core can be used, for example, as this will proportionately reduce the number of turns required in both primary and secondary.

Alternatively, a larger size of stamping may be needed. Stalloy stampings, size No. 4, are suitable for small transformers, such as the one described. Enough should

be bought to make a core 1 inch thick or a little greater if necessary.

The procedure in estimating the details of a transformer is, therefore: (1) Find the size of the core, (2) work out the number of turns per volt to suit core and also fre-

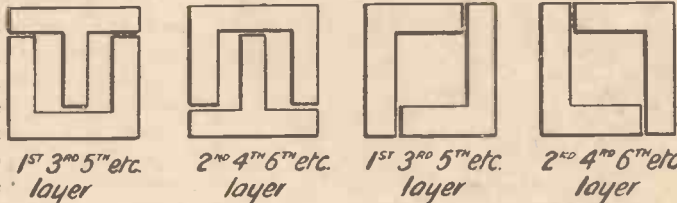

Fig. 2

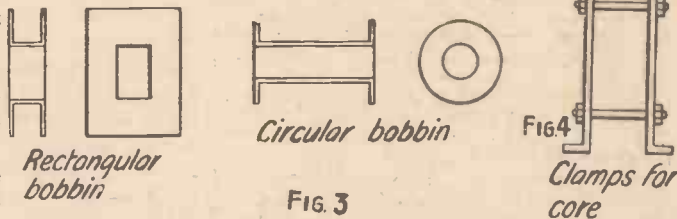

Fig. 3

Fig. 2. Details of cores. Fig. 3. Rectangular and circular bobbins. Fig. 4. Clamps for core

quency of supply, (3) find total turns for primary winding by multiplying the turns per volt of the voltage of the supply, (4) work out turns needed in secondary coil, (5) find size of wire for secondary coil to carry the full load current, (6) estimate the current flowing in the primary, and then decide size of wire.

**Insulation**

Finally, settle the insulation to be used and see whether there is room for the wire on the core.

Having settled on a design which seems satisfactory, build a bobbin for the primary coil from paxolin or even cardboard. The

**TANNOY**

**WORK YOUR SET FROM THE MAINS**

ARE YOU GOING TO MAKE A SET? If so incorporate a Tannoy mains unit which will give perfect H.T. and L.T. for ever. If you have already got a good set buy a Tannoy combined unit which only takes a minute to connect and then you "switch on." No batteries to run down but more volume with constant supply.

H.T. .... from £2 : 7 : 6  
L.T. .... " £1 : 18 : 0

Combined H.T. and L.T.  
£5 : 12 : 6 (complete).

The TULSEMER MFG. CO.,  
1-7, Dalton Street, West Norwood,  
S.E. 27. Phone: Streatham 6731.

**Mains Units**

FULL-SIZE BLUEPRINTS

When ordering, please send Postal Order, NOT STAMPS

CRYSTAL SETS (6d. each)

Table listing Crystal Sets with items like B.B.C. Brookmans Park Set and Regional Crystal Set.

ONE-VALVE SETS (1s. each)

Table listing One-Valve Sets with items like B.B.C. Official One and Reinartz One.

TWO-VALVE SETS (1s. each)

Table listing Two-Valve Sets with items like Loud-speaker America Two and Talisman Two.

THREE-VALVE SETS (1s. each)

Table listing Three-Valve Sets with items like The Binowave Three and Broadcast Three.

FOUR-VALVE SETS (1s. 6d. each)

Table listing Four-Valve Sets with items like Overseas Short-waver and Clarion All-electric Three.

FIVE-VALVE SETS (1s. 6d. each)

Table listing Five-Valve Sets with items like Fidelity Five and All-wave Lodestone Five.

AMPLIFIERS (1s. each)

Table listing Amplifiers with items like A.W. Gramophone Amplifier and Beginner's Amplifier.

MISCELLANEOUS (1s. each)

Table listing Miscellaneous items with items like Short-wave Adaptor and High-tension Battery Charger.

PORTABLE SETS

Table listing Portable Sets with items like Arcadian Portable and Holiday Portable.

Three prints are obtainable for 2s. 6d. post free... Copies of the "Wireless Magazine" and of "Amateur Wireless" containing descriptions of any of these sets can be obtained at 1s. 3d. and 4d. respectively, post free.

AMATEUR WIRELESS 55-61 FETTER LANE LONDON, E.C.4

illustrations show suitable bobbins, but the central part may be circular if the construction is made more easy. Then put on the wire, winding tightly.

If enamelled wire is used, a layer of paper should be put on every few layers of wire. Wind carefully, layer by layer. The end of the wire should, of course, be brought out through a hole, and not up the side of the bobbin, and the coil ought to have a wrapping of tape to hold the outer layer firmly.

With the winding finished, the core should be assembled. Fit the core pieces as shown in the sketches, and be sure they are laid properly. Do not damage the coils when filling them with stampings.

Clamps must now be prepared and fitted. They must be bolted tightly and the core firmly secured. Suitable clamps are sketched; they have feet for fixing. The laminations will buzz if they are not made tight and, incidentally, the windings themselves may buzz if of enamel wire loosely wound.

MESSRS. SELFRIDGE AND THE "BEST-BY-BALLOT 3"

THE Selfridge advertisement on page 151 of last week's issue had rather the appearance of a missing-word competition. The price at which the set of components for the "Best-by-BalLOT 3" is supplied by Messrs. Selfridge was represented by a blank. Messrs. Selfridge want us to make it perfectly clear to AMATEUR WIRELESS readers that they are supplying, carriage paid in England and Wales, all components for this already famous set, exactly as specified by AMATEUR WIRELESS, for twelve monthly payments of 12s. 1d., or at the cash price of £6 18s. 6d. With this information the Selfridge announcement in last week's issue becomes immediately intelligible.

It should be noted that the special free valve offer made in the Fotos advertisement on page 151 of AMATEUR WIRELESS No. 398 applies for a period of 14 days only.

SELECTIVITY GUARANTEED!

"THE BROOKMAN'S BY-PASS 3," A UNIQUE RECEIVER SPECIALLY DESIGNED FOR THE NEW CONDITIONS.

Full Details Next Week.

The German coastal station of Kiel (D.B.K.) since December 15 has opened a wireless telephony service of meteorological reports and weather forecasts on 680 metres (441.2 kilocycles). Broadcasts are made at 7.00, 10.10, 13.00, 16.10, and 18.00 G.M.T.

RAYMOND'S

27 & 28a, LISLE ST., LONDON, W.C.2. Come to LEICESTER SQUARE TUBE.

This address is at the back of DALY'S THEATRE. Phones: Gerrard 4637 & 2821

WE ARE OPEN TUNEWELL ALL DAY SATURDAY ALL DAY THURSDAY ALL DAY EVERY DAY. Hours 9 a.m. to 8 p.m. Sat. 9 a.m. to 9 p.m. Sunday morning 11-1

BEST-BY-BALLOT 3 A.W., JANUARY 30th Screened Grid, D. & P.

Table listing parts for Best-by-BalLOT 3 with prices and descriptions like 2.0005 Lotus, Reaction .0001, 15 ohm Rheo, etc.

TOTAL Parts £5 11 9 12 MONTHLY PAYMENTS OF 12/-

MARVELLOUS CASH BARGAIN! AMAZING OFFER IN LOUD-SPEAKER RECEIVERS

DE LUXE MODEL READY TO USE



For Local, Brookmans Park, 5GB, and new alternative programmes. Many Continental Stations. NO COILS TO CHANGE

WONDERFUL ★ UNSOLICITED TESTIMONIAL Hatfield, Jan. 20th, 1930 Purchased your complete Receiver Friday night. TUNED IN 5GB and CUT OUT 21.0. I consider this a very fine achievement as I am only 2 1/2 miles from Brookmans Park. Best of luck. (Signed) G. PRICE.

Complete Receiver READY TO USE as shown above. Assembled in AMERICAN CABINET (hinged lid) all parts enclosed: DUAL WAVE COIL is incorporated (200/2000); GRID BIAS BATTERY; 4 WAY LEADS; 3 DULL EMITTER VALVES; 2 SLOW MOTION DIALS. TRANSFORMER COUPLED. Packing & Carr. 5s. U.K. NOT C.O.D.

BATTERIES AND SPEAKER EXTRA. EASY TERMS 12 MONTHLY PAYMENTS OF 7/9 OR

COMPLETE RECEIVER THE LOT (AS ABOVE) WITH 100-volt H.T., 2 v. 40 L.T., Amplion Cone Speaker Aerial Equipment. Carr. 7/6

EASY TERMS (the lot) 12 MONTHLY PAYMENTS OF 7/11 Easy Payment Forms Free if Plat. or Householder.

KITS OF PARTS of your own selection. Quoted for at a special cash price where possible OVER 25/- on receipt of detailed list. In value

BRITAIN'S FAV. 2 BROADCAST 2 TALISMAN 2 Batteries and Speaker extra. SPECIAL OFFER Assembled to a nice cabinet with Power and D Valves. Best components and specified Coll. Tested Ready to use. EITHER OF ABOVE 70/- CASH Carr. 2/6

CLARION S.G. 3 Approved SET OF PARTS See previous issue or LIST FREE. CASH 70/- Carr. paid EASY TERMS KITS OF PARTS, with 2 Tunewell Clarion Coils, panel, strip, all screws, wire and sundries, 14 by 7 Cabinet (hinged lid), baseboard, S.G. Mullard Valve, 2 D.E. Valves, Blueprint.

12 MONTHLY PAYMENTS OF 7/11 12 monthly payments of 12/9 BATTERIES, VALVES, COMPONENTS, COILS. All makes stocked. SPECIAL BARGAINS THURSDAYS

**GET THE BEST OUT OF YOUR SET**



**WHAT STATION WAS THAT?**

**1/9 POST FREE**

WITH this simple RADIO STATION FINDER no technical knowledge is necessary for you to identify immediately, and with certainty, any station calling, or for you to tune in to any station you like. Can be used with any valve set and eliminates oscillation. Calibrates your set in a few minutes. Enjoy right away the full value of your set by finding more and more stations every night. The B.G.L. Radio Station Finder makes it simple for you to pick up any station you choose. Handsomely finished, complete with full instructions, 1/9 post free. Cash with order.

Fill in this coupon and post to-day.

To BRITISH GAMES LTD. (Dept. A.W.),  
19 Clerkenwell Close, London, E.C.1.

Please send me your Radio Station Finder, post free, for which I enclose you postal order for 1/9.

Name \_\_\_\_\_

Address \_\_\_\_\_

**B.G.L. RADIO STATION FINDER.**

**750 WATT "Q.M.B." SWITCH 2/6**



LYONS' NEW "B.A.T." (Best-After-Test) QMB Switch breaks 3 amps. at 250 volts! For H.F., L.F., H.T., L.T., circuits. For A.C. Sets, Mains Units, Gramo-Motors, and as Moving Coil Speaker Field Switch, etc. Send for FREE 4-pp. circular; request at the same time our famous 36-pp. "CLAROSTAT" Book (all about D.C. and A.C. Mains Units, with scale drawings).

**CLAUDE LYONS, LTD.,**  
76 OLDHALL STREET,  
LIVERPOOL : ENGLAND

**BEAUTIFY YOUR SET!** Radio Furniture De Luxe from £3 15s. to £11 11s. Sent ON APPROVAL—you may return at our expense if you wish to part with it. Used by Radio Press—over 3,000 clients.

**PHOTOGRAPHS & LIST FREE**  
Pickett's Radio Furniture Workshop (A.M.) Bexley Heath

**TAYLEX WET H.T. BATTERIES**

New Prices: Jars 1/3. Sacs 1/2. Zincs 10d. Sample doz. 18 Volts complete with bands and electrolyte 4/1 post 9d. Sample unit 6d. Illus. booklet free. Bargain list free. AMPLIFIERS, 30/- 3 VALVE ALL-STATION SET £5

A. TAYLOR, 57, Studley Road, Stockwell LONDON.

**GRAMOPHONES LATEST HORNS AND PARTS**

CATALOGUE FREE. CASH OR TERMS.  
BUILD #12 MODEL FOR £3. INSTRUCTIONS 3L

W. BURT 185 High St., Dentford, London. S.E.8

**NEXT WEEK:**

**"Brookman's By-pass 3"**

A Set incorporating its own Wavetrap

**GRAMO-RADIO NOTES**

*Surface Lubricants*

FREQUENTLY inquiries reach me as to whether or not the use of a surface lubricant for records is to be recommended. The advocates of such greases and patent compositions point out that when the lubricant has been evenly spread over the surface of the record the needle glides smoothly along the sound grooves and, since friction must be materially lessened, wear must also be proportionately decreased. Also the use of such compositions, which vary from thin special oils to waxes having the consistency of candle grease, tends to lessen needle scratch. These advantages are true to a certain extent, but really they can only be said to apply when the lubricant has been freshly put on the record.

*Effect of Dust*

Most oils, fats, greases, etc., harden in time due to oxidation, and if you only play your records at intervals the use of these lubricants and patent compounds is not advised. Further, there is one other great disadvantage: all the atmospheric dust and gritty particles which settle on a record stick because of the greasy surface and with subsequent playing become ground into the sound track. Under these circumstances wear and scratch may be appreciably increased. Surface lubricants are sometimes used to help the points of fibre needles from breaking down. Since a fibre needle operates on the principle that if two surfaces are in frictional contact wear will take place at the softer surface, quite a fair amount of fibrous material worn from the point in playing collects in the groove. If a sticky or gummy grease is spread over the surface of the track, the groove very quickly fills up.

A. McDONALD.

**"Amateur Wireless and Radiovision." Price Threepence.** Published on Thursdays and bearing the date of Saturday immediately following. Post free to any part of the world: 3 months, 4s. 6d.; 6 months, 8s. 9d.; 12 months, 17s. 6d. Postal Orders, Post Office Orders, or Cheques should be made payable to "Bernard Jones Publications, Ltd."

**General Correspondence** is to be brief and written on one side of the paper only. All sketches and drawings to be on separate sheets. Contributions are always welcome, will be promptly considered, and if used will be paid for. Queries should be addressed to the Editor, and the conditions printed at the head of "Our Information Bureau" should be closely observed. Communications should be addressed, according to their nature, to The Editor, The Advertisement Manager, or The Publisher, "Amateur Wireless," 58-61 Fetter Lane, London, E.C.4.

**OUR BLUEPRINT SERVICE**

Constructors of receivers described in this Journal should make full use of our Blueprint Service and avoid all risk of failure.

**REPAID ADVERTISEMENTS**

Advertisements under this head are charged **THREEPENCE PER WORD**, minimum charge **THREE SHILLINGS.**

**DEPOSIT SYSTEM**

As the Publishers cannot accept responsibility for the bona fides of advertisers in this publication, they have introduced a system of deposit which it is recommended should be adopted by readers when dealing with persons with whom they are unacquainted. It is here explained.

Intending purchasers should forward to the Publishers the amount of the purchase money of the article advertised. This will be acknowledged to both the Depositor and the Vendor, whose names and addresses must necessarily be given. The deposit is retained until advice is received of the completion of the purchase, or of the article having been returned to and accepted by the Vendor. In addition to the amount of the Deposit, a Fee of 6d. for sums of £1 and under, and 1s. for amounts in excess of £1, to cover postage, etc., must be remitted at the same time. In case of persons not resident within the United Kingdom, double fees are charged.

The amount of the Deposit and Fee must be remitted by Postal Order or Registered Letter (Cheques cannot be accepted), addressed to "AMATEUR WIRELESS," ADVERTISEMENT DEPARTMENT, 58/61 FETTER LANE, LONDON, E.C.4.

**PATENTS.**—Trade Marks, Advice Handbook free.—D. T. King, Regd. Patent Agent, 146a Queen Victoria Street, London.

**MAINS TRANSFORMERS 21/-; L.F. CHOKES, 15/-** Makers of all types, all ratios. REPAIRS any make Transformer, Loud-speaker or Headphones, 4/- post free. Twelve months guarantee. COUNTY SERVICE, MICKLEOVER, DERBY.

**MAGIC PLUG-IN COILS.**—Low loss, efficient, tested, guaranteed. 2s. 10d.; 3s. 4d.; 5s. 1/1; 6s. 7s. 1/4; 10s. 15s. 1/8; 20s. 2/2; 25s. 2/8. CT 6d extra. X1-extra. Wave trap coil 1/6. Postage 3d. any quantity. Johnson, 31 Rosemead Avenue, Wembley.

**BANKRUPT BARGAINS.**—Sutra or Falco L.F. transformers 2/9; Telsen ACE 5/6. Cone units 4/-; Bullphone 6/- Adjustable 'phones 3/6 pair. .0005 SLF Condensers 1/6. Wavemaster .0005 2/9. Fellowes AC Rectifiers 20/- Raderox Power Transformers 8/6. Dario Valves 3/6. Ecco and other D.C. units. Formodensers 1/6, Fixed 6d. Coil Mounts 3d. Quantity various Coils cheap. List free. J. Butlin, 143b Preston Road, Brighton.

**ELEX**

**MOISTURE RETAINING EARTH BOWL**



Collects and retains all available moisture—improves with age—immune to atmospheric conditions—that is the Elex "earth"! Supplied with 9ft. rubber-covered lead and connector, price 5/6 each. Write for list 1/8.

**J. J. EASTICK & Sons,**  
Elex House, 118, Bunhill Row, London, E.C.1

**REPAIRS**

Any make of L.F. Transformer, Loud-speaker or headphones repaired and dispatched within **48 HOURS—TWELVE MONTHS' GUARANTEE** with each repair. 4/- Post Free.

Terms to Trade

**TRANSFORMER REPAIR CO.**  
"Service" Dept.  
214 High Street, Colliers Wood, London, S.W.19

**EASY TERMS**

We SPECIALISE in the supply of all Good Quality Radio Sets, Components and accessories on Easy Terms. We will give you efficient service. Send us your list of requirements and a quotation will be sent by return.

**LONDON RADIO SUPPLY COMPANY**  
11, Oat Lane, Noble St., London, E.C.2  
NATIONAL 1977

**EUREKA**

The L.F. Transformer that gives Really First Class Reproduction at a low cost.

Baby Grand 1st or 2nd stage	8s. 6d.
Concert Grand 1st stage	10s. 6d.
Concert Grand 2nd stage	9s. 6d.
Smoothing Chokes 20h. 40m/a.	10s. 6d.

All Post Paid by return. Money refunded if not satisfied in 7 days.

**L. PERSON & SON**  
(Dept. 6), 63, Shaftesbury Street, London, N.1.

**Amateur Wireless** **COUPON**  
Available until Saturday  
**FEBRUARY 8, 1930**

# Build the "BROOKMAN'S BY-PASS"

*in this issue*

We can supply  
from stock IMMEDIATELY

## THE *Harlie* COIL As Described

**PRICE**  
**3/3**  
*Post Free.*

Accurately wound to Mr. Reyner's detailed instructions and passed by "Amateur Wireless." Use this coil and ensure success. Have you particulars of the other Harlie Components for Radiant Radio Reception? Send p.c. for full list to:—

**HARLIE BROS.**  
Dept. H.2, Balham Road, Edmonton, London, N.9  
Phone: Tottenham, 3446

# 3 REASONS

Wireless constructors prefer a Trolitax panel because

1. Trolitax gives perfect insulation.
2. Trolitax can be relied upon in all circumstances.
3. Trolitax offers a choice of handsome designs including some new wood finishes.

Ask to see the new screened panel. Trolitax with a metal back *sprayed on*—something entirely new!

# TROLITAX

**F. A. HUGHES & CO., LIMITED**  
204-6 Great Portland Street, London, W.1  
Phone: Museum 8630 (4 lines)

*Distributors for Northern England, Scotland and North Wales:*  
**H. C. RAWSON (SHEFFIELD & LONDON) LTD.**, 100 London Road, Sheffield (Phone: Sheffield 26006); 22 St. Mary's Parsonage, Manchester (Phone: Manchester City 3329.)



## DUBILIER FOR STAUNCH RESISTANCES

### DUMETOHMS



.25, .5, 1, 1.5, 2, 3, 4, 5 and 10 Megohms. Other Higher Values specially to order.  
Each

2/6

### RESISTORS



Any standard value Each // - Holder (Horizontal or Vertical) Each // -



### DUMETOHM HOLDERS

Vertical or Horizontal  
Each 1/-

### DUWIROHM



(Horizontal Type)

10,000 to 100,000 ohms 5/-  
150,000 and 200,000 ohms 8/-  
250,000 ohms 9/9  
300,000 ohms 11/6  
Holder for horizontal type 1/6

**FREE**  
for the asking—  
the Dubilier Book—  
let entitled "A Bit  
about a Battery."  
Get a copy from  
your dealer.

# DUBILIER RESISTANCES

If you have any difficulty in obtaining Dubilier Products, please write direct, giving your Dealer's name and address, to

**DUBILIER CONDENSER CO. (1925) LTD.,**  
Ducon Works, Victoria Rd., N. Acton, London, W.3

Cleaver

BC 278. R

To Ensure Speedy Delivery, Mention "A.W." to Advertisers

# PREDOMINANT IN ITS OWN SPHERE

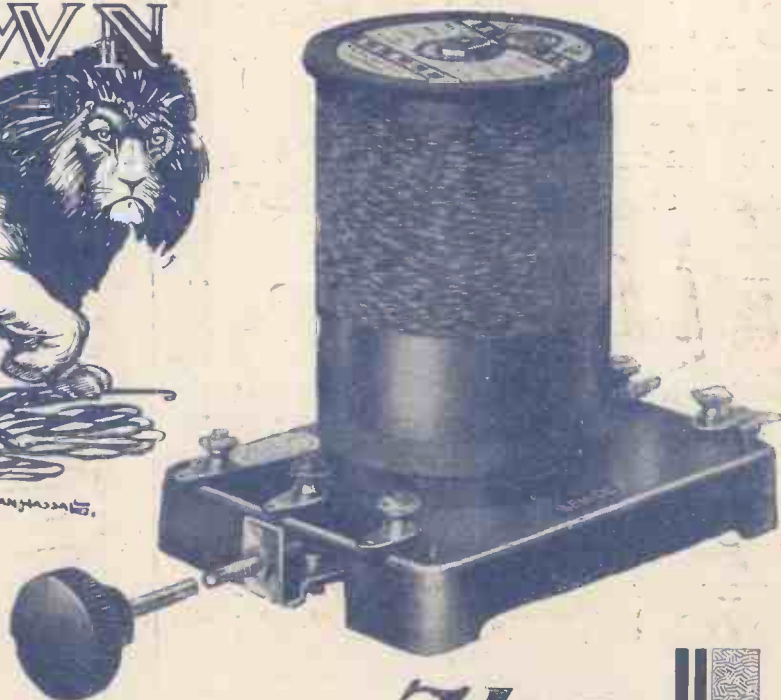

## The LEWCOS Q COIL

Just as the Lion is Lord of the Jungle, so is the Lewcos "Q" Coil master in its own field. The work of the Lewcos "Q" Coil is to clarify reception and, like all other Lewcos Coils, it acquires itself magnificently.

A fully descriptive leaflet (Ref. R35) of the "Q" Coil will be sent on request. **WRITE FOR IT TO-DAY.**

Lewcos "Q" Coils (Ref. Q.A.T., Q.S.G.) are specified for the "Best-by-Ballot 3," described in this issue.

**PRICES:**

- Aerial Coil, Ref. SP/QAT, QAT
- Split Primary Transformer, Ref. SP/QSP, QSP
- Screened Grid Transformer, Ref. SP/QSG, QSG

**15/-**  
EACH



THE LONDON ELECTRIC  
WIRE COMPANY AND  
SMITHS LIMITED  
Church Rd., Leyton, London, E.10

Trade Counter:  
7, PLAYHOUSE YARD  
GOLDEN LANE  
E.C.1

**LEWCOS RADIO PRODUCTS FOR BETTER RECEPTION**