

Practical
TELEVISION SERVICING
and
TROUBLE SHOOTING
MANUAL



A *Coyne* PUBLICATION

**APPLIED
PRACTICAL
RADIO-
TELEVISION**

ACKNOWLEDGMENT

We wish to acknowledge and express our appreciation for the assistance and co-operation given to us by the following companies in supplying data and illustrations for the preparation of this book.

DUMONT COMPANY

WESTINGHOUSE ELECTRIC & MFG. Co.

GENERAL ELECTRIC Co.

CROSLY RADIO & TELEVISION CORP.

SYLVANIA ELECTRIC PRODUCTS Co.

R. C. A. MANUFACTURING Co.

PHILCO RADIO & TELEVISION Co.

ADMIRAL RADIO & TELEVISION CORP.

MOTOROLA RADIO & TELEVISION CORP.

STEWART-WARNER CORP.

COLUMBIA BROADCASTING SYSTEM

APPLIED PRACTICAL RADIO-TELEVISION

*A Practical Book
on FM Radio and Television
Covering*

**TELEVISION SERVICE METHODS
TUNERS OR FRONT ENDS
TELEVISION SOUND AND ALIGNMENT
METHODS
VIDEO I-F AMPLIFIERS
TRAPS FOR INTERFERENCE
VIDEO DETECTOR AND AMPLIFIER
PICTURE TUBES
SYNC SECTIONS
SWEEP OSCILLATORS OR GENERATORS
HIGH VOLTAGE AND LOW VOLTAGE
POWER SUPPLIES
SWEEP FREQUENCY AUTOMATIC CONTROLS
AND OUTPUTS
TROUBLE LOCATION WITH TEST PATTERNS
ANTENNAS
COLOR TELEVISION AND UHF
TV BOOSTERS — LONG DISTANCE
RECEPTION**

by
THE TECHNICAL STAFF
of the
COYNE ELECTRICAL SCHOOL
CHICAGO 7, ILLINOIS

Copyright, 1955 by
COYNE ELECTRICAL SCHOOL, INC.
1501 W. Congress Pkway.
Chicago, Illinois

All rights reserved. This book or any parts thereof may not be reproduced in any form without written permission of the publishers.

1961 EDITION

Printed in the United States of America

FOREWORD

"The Federal Communications Commission under the new allocation plan proposes to assign 499 Television stations in the VHF band to serve 205 cities, also 1682 stations in the UHF band to serve 1330 cities." This quotation taken from the new U. S. Dept. of Commerce bulletin TELEVISION AS AN ADVERTISING MEDIUM provides some idea of the future opportunities for the television serviceman.

This same booklet mentions the fact that consumer demand for television sets HAS FAR EXCEEDED EVEN THE MOST OPTIMISTIC PREDICTIONS OF THE INDUSTRY. With a potential market of over 37,620,000 homes now having radio and the promise of the FCC "to provide each community with at least one television broadcast station" it is easy to see why the future for the radioman in television is tremendous.

With the record of progress already made and the unlimited future in Television it was obvious that a manual was needed for the radioman who wished to get into Television. Coyne proceeded to use every means at its disposal to prepare such a book. The result after several months of preparation, research and editing is the book you now hold in your hands.

COYNE PRACTICAL TELEVISION SERVICING AND TROUBLE SHOOTING MANUAL is no theoretical treatise of television—it is a book of fast, time saving methods for servicing television receivers. It includes dozens of new testing ideas all of which have been proven on the job.

Most of the leading television manufacturing companies have "had a hand" in the preparation of this book. They have furnished service manuals, photos and thousands of pages of service data. This data was then analyzed and CONDENSED to retain all the important material without too much theory. The result, we feel, brings the radioman a valuable book for study and particularly for field reference—a book that shows how radio knowledge can be applied to help solve television problems. You will see in this book that while television is NEW it nevertheless combines many technical phases of the early days of radio.

This constant effort throughout the book to show a radioman how he can use his radio knowledge together with this book to service television receivers makes the book interesting and enables a man to easily acquire a knowledge of television servicing.

FOREWORD

The book is well illustrated with over 200 crystal clear photos and diagrams. While these add a great deal to the cost of a book they are essential for easy understanding. Every possible effort has been made to make this book **THE PRACTICAL BOOK THE RADIOMAN IS LOOKING FOR TO HELP HIM TO GET INTO TELEVISION.**

The final chapter of the book is devoted to **COLOR TELEVISION** and the UHF channels. For the greatest possible clarity we have printed this section in color. The latest technical data on these subjects has been furnished by the leading Television companies. This material, which includes many photos, diagrams, circuits, etc., of actual Color Television equipment should give the reader a good idea of the equipment and problems he can expect in the future. The special instructions on essential changes required to accommodate the UHF channels should be of great interest and value to the practicing serviceman.

Today, Television finds itself on the threshold of one of the greatest futures every offered to any industry. Radio has prepared the way and everyone of the millions of homes with radio will be a potential customer for television. **AND THE SERVICE FIELD SHOULD BE ONE OF THE MOST ACTIVE OF THE INDUSTRY BECAUSE IN TELEVISION TROUBLE CAN DEVELOP IN TWO WAYS—SOUND OR PICTURE. THIS MEANS DOUBLE THE OPPORTUNITY THAT THE RADIOMAN HAS ENJOYED IN THE PAST WHEN THERE WERE ONLY PROBLEMS IN SOUND TO CONTEND WITH.**

We confidently feel you will find constant use for the **PRACTICAL TELEVISION SERVICING AND TROUBLE SHOOTING MANUAL** and that it will become increasingly valuable the further you go into the great field of **TELEVISION.**

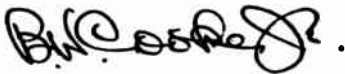

B. W. COOKE, JR., *President*
Educational Book Publishing Division
COYNE ELECTRICAL SCHOOL

TABLE OF CONTENTS

	Page
TELEVISION SERVICING METHODS	1-18
Rasters (how they indicate sources of trouble), Localizing faults, Patterns, Systematic trouble shooting, Waveform analysis and circuit tests, Complete tracing of television signal from antenna to picture tube, Modulation, Frequencies, Channels.	
TELEVISION SERVICE INSTRUMENTS	19-50
What they are—how to use them, Sweep generators, Oscilloscopes, Tracing, Detector probes, Synchronizing sweep, Phasing, Marker generator, Electronic voltmeters, etc.	
TELEVISION TUNERS (The Front End)	51-70
Parts, Continuous tuning, Rf Oscillator, Oscillator frequency, Drift, Tuner designs, Channel switching, Individual alignment, Adjustments, Turret tuners, 2-band continuous tuners, etc.	
TELEVISION SOUND	71-82
Sound takeoffs, Sound I-f amplifiers, Discriminators, Ratio Detectors, Inter-carrier sound systems, etc.	
VIDEO I-f AMPLIFIERS	83-106
Receiver attenuation, Intermediate frequencies, Automatic gain control, Interference traps, Traps for intercarrier beat, Stagger tuned and overcoupled stages, Effects on test patterns.	
ALIGNMENT OF VIDEO I-f AMPLIFIERS	107-141
Alignment practices, Alignment of traps, Video I-f alignment, Interstage coupling, Aligning single peak impedance couplers, Double peak couplers, Alignment of individual stages, Intercarrier sound, Regeneration, etc.	
ALIGNMENT OF THE SOUND SECTION	142-160
Preparing for alignment, Interstage coupler, Alignment with Voltmeter, Demodulator, Alignment with electronic voltmeter, Alignment with oscilloscope, Demodulator alignment.	
ALIGNMENT OF TUNERS	161-192
Rotary switch tuner, Overall alignment, Adjustments affecting all channels, 2-Band continuous tuner, Adjustable inductors, Tuning wand, Matching of generator impedance, R-f and antenna alignment, Aligning with oscilloscopes, Trap alignment, Effects of oscillator frequency, Oscillator alignment for sound intermediate frequency, Oscillator alignment with intercarrier sound.	
VIDEO DETECTOR and AMPLIFIER	193-204
Signal polarity, Detector circuits, Crystal detectors, Waveforms, Connections for observing the signal waveform, Video amplifier, Alignment of trap for intercarrier beat.	

TABLE OF CONTENTS Continued

	Page
PICTURE TUBE INPUT CIRCUITS	205-216
Composite signals, DC component of signal, DC restoration at video amplifier, Restoration at picture tube cathode, Restoration with a diode, Weak signals and what to do about them, Service procedure.	
THE SYNC SECTION	217-226
Waveforms in the Sync section, Trouble shooting, Tubes in the Sync section, Separation of horizontal and vertical pulses, Filters, Capacitances, Diagrams.	
SWEEP OSCILLATORS	227-243
Connections for a blocking oscillator, Traces, Multivibrator sweep oscillator, Polarity of oscillator Sync pulses, Sawtooth and square pulse voltage, Hold and size controls, Patterns, Adjustment procedures.	
AUTOMATIC CONTROL of SWEEP FREQUENCY	243-263
Reactance tube, Afc discriminator, Phase detector, Hold control action, Phase detector to multivibrator, Oscillator bias for Afc, Oscilloscope traces, Afc diode for oscillator bias, Sweep timing.	
SWEEP AMPLIFIER and DEFLECTION CIRCUIT	263-298
Electrostatic deflection amplifiers, Magnetic deflection amplifiers, Horizontal amplifiers for magnetic deflection, Resistance control for peaking or drive, Capacitor drive control, Oscilloscope traces, Width control on transformer, Patterns, Damper action, Methods of linearity control and adjustment, Triode damper tube.	
PICTURE TUBE SERVICE and ADJUSTMENTS	289-306
Effects of Anode voltage, Picture tube masks, Handling of picture tube, Deflection coils, Circuits, Centering controls, Ion trap, Patterns, Focusing, etc.	
TELEVISION POWER SUPPLIES	307-326
Flyback high voltage systems, Voltage doublers, Oscillator high voltage system, High voltage rectifier, Corona discharge and flashover, Low voltage B supplies, Series-parallel plate cathode circuits.	
TELEVISION ANTENNAS	327-346
Dipole antennas, Antenna length and wave length, Directional effects, Reflectors and directors, 2-band antennas, Stacked dipoles, Impedance matching, Where to place antennas, Special hints for best performance of antennas, Test sets for antenna installation, How to erect antennas, etc.	
COLOR TELEVISION and ULTRA HIGH FREQUENCIES	347-396
Scanning or color switching, Color cameras, Reception with dichoric mirrors, The CBS, RCA and other types of systems. Photos of actual color television sets and studio broadcasting equipment, Service problems in color television, Ultra high frequencies. Changes necessary in present sets to accommodate new UHF channels, The future of television.	
TV BOOSTERS — LONG DISTANCE RECEPTION	400-406

Chapter 1

TELEVISION SERVICE METHODS

It is not especially difficult to locate the cause for faulty performance in a radio receiver having only six or eight tubes. Tests for voltage, resistance, and continuity may be made at all tubes and circuits in a reasonably short time. But television receivers of common types have twenty to forty tubes, and many unusual circuits. Furthermore, the composite signal for television carries not merely a limited range of audio frequencies, but includes many different kinds of signals which must find their respective ways into certain sections of the receiver.

Of course, it would be possible to commence at one end of a television set and make the ordinary tests of voltage, resistance, and continuity until reaching the circuit or part in trouble, but this would take a great deal of time. To save time we must reduce

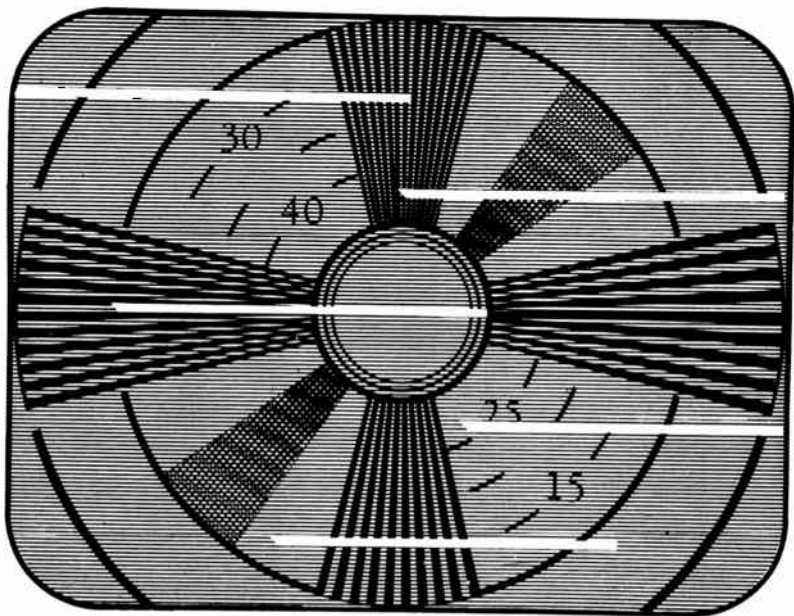

Fig. 1-1.—Test patterns are designed to help make service adjustments and locate troubles.

2 APPLIED PRACTICAL RADIO-TELEVISION

television servicing to a system which quickly identifies the parts or sections at fault, and which wastes no effort on those which cannot be causing trouble.

Fast service of high quality requires the use of instruments such as sweep generators, marker generators, oscilloscopes, and electronic voltmeters, whose applications we shall consider. But before resorting to such specialized equipment we should employ two test instruments which are built right into every television receiver—the picture tube and the loud speaker.

To enable you to make the best possible use of the picture tube for trouble shooting, television stations transmit before their entertainment programs a “test pattern” of the general style pictured by Fig. 1-1. In addition to being the station identifica-

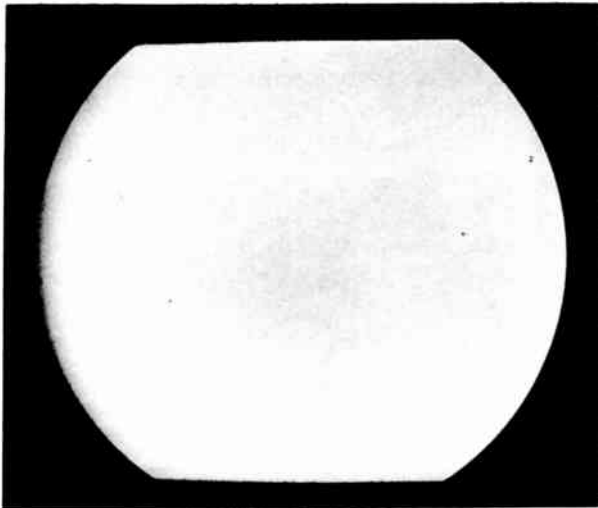

Fig. 1-2.—The appearance of the raster helps locate certain troubles.

tion, this pattern provides, lines, wedges, and circles of many kinds which are designed to help make correct adjustments of all operating and service controls, and to determine the kinds of faults which may be present.

In using the picture tube and loud speaker for trouble location there are three things to be observed. First is the test pattern, if it is being transmitted. If no test pattern is available you will have to watch any regular program picture. although pictures

are not so helpful. Second is the sound from the loud speaker. Third is the raster, without pattern or picture. A raster, shown by Fig. 1-2, is the illumination of the picture tube screen produced by sweeping of the electron beam from left to right and downward. To observe the raster, set the tuner control or channel selector to any channel in which there is no signal at the time of testing and turn up the brightness control until the screen is lighted.

Each of these three things, picture or pattern, raster, and sound, may be either good, poor, or absent. Various combinations of these conditions indicate which sections of the receiver probably are causing trouble, and, of equal help, show which sections need not be considered in looking for the fault. To illustrate this method in a general way we shall consider a television receiver as consisting of the major sections shown by the block diagram of Fig. 1-3, as follows:

A. The tuner or front-end. The antenna coupling, r-f amplifier, mixer or converter, r-f oscillator, and whatever tuning and switching arrangements are used for channel and station selection.

B. I-f amplifier for sound and video. This is any portion of the

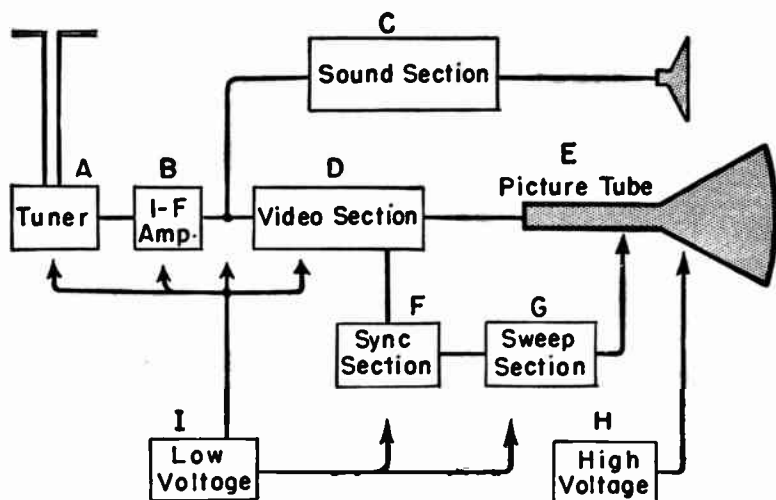

Fig 1-3.—As a first step in trouble shooting we try to localize the fault one of these major sections.

4 APPLIED PRACTICAL RADIO-TELEVISION

i-f amplifier which is ahead of the takeoff for sound or ahead of sound-video separation.

C. Entire sound section, from takeoff through the loud speaker.

D. Entire video section. The remainder of the video i-f amplifier, the video detector, video amplifier, d-c restoration, and all else leading into the grid-cathode input circuit of the picture tube.

E. The picture tube itself.

F. The sync section, from the point of sync-video separation through the filters for vertical-horizontal separation which feed the sweep generators or oscillators.

G. The sweep section. The sweep generators or oscillators, output amplifiers, and all else up to and including the deflection coils or plates of the picture tube.

H. The high-voltage power supply which feeds the high-voltage anodes of the picture tube.

I. The low-voltage power supply which feeds all other circuits

PATTERN OR PICTURE	RASTER	SOUND	Tuner	IF (video-sound)	Sound section	Video section	Picture tube	Sync section	Sweep section	Power, high-v	Power, low-v
Good	Good	Bad	2		1						3
Poor	Good	Bad	1	1	2	3					
Poor	Poor	Good	3	3		2	3	2	1	3	3
Poor or None	Good	Good				1	3	2			
Poor or None	Poor or None	Bad	1	1	3	3	3	3	1	3	2
None	Good	Bad	1	1	3	2	3	3			2
None	Poor	Good				2	2	2	1	2	3
None	None	Good				3	3	3	1	2	3

Fig. 1-4.—Probable locations of faults as indicated by the picture tube and loud speaker of the receiver.

for plates, screens, grids, remaining picture tube anodes, and heaters or filaments.

Probable locations of faults, as indicated by picture tube and loud speaker, are shown by Fig. 1-4, or by some similar table suited to a particular make and model of receiver. At the left are columns listing the combinations of observed conditions. Across the top are listed the major parts of the receiver. At the intersections are numbers corresponding to the order in which the major parts should be examined.

As an example, the first combination of conditions includes a good pattern or picture, good raster, and bad sound. The numbers 1, 2 and 3 show that we should examine first the sound section, second the tuner, and third the low-voltage power supply, this

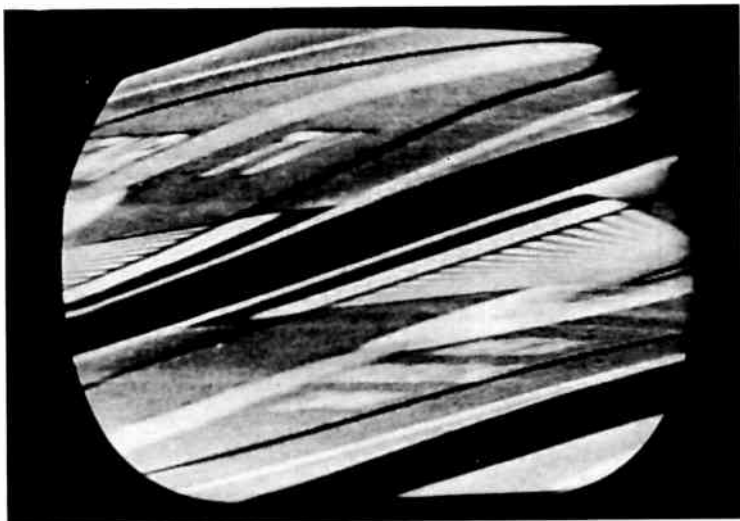

Fig. 1-5.—This pattern indicates that the horizontal sweep oscillator is slightly out of synchronization.

latter only in case there is a separate supply for the sound section. In remaining sections, for which there are no numbers, it is highly improbable that any fault exists.

The next combination, poor pattern or picture, good raster, and bad sound, gives the number 1 for both the tuner and the i-f amplifier which carries video and sound. This means that both these sections are equally likely to be at fault. If both tuner and

6 APPLIED PRACTICAL RADIO-TELEVISION

video-sound i-f amplifier are found in good order, we go next to the sound section, numbered 2, and finally to the video section, numbered 3.

The third combination, poor pattern or picture, poor raster, and good sound, lists the most likely seat of trouble, number 1, as the sweep section. After that we should look at both video and sync sections, since both have the number 2. If the trouble has not been located we should examine all sections having the number 3. Only the sound section has no number, and may be passed over without checking.

So far we have classed patterns or pictures as either good, poor, or absent. But a pattern may be poor in a great many different ways. As examples of how test patterns may indicate particular troubles, the one of Fig. 1-5 shows misadjustment or other trouble in the horizontal hold control, while the one of Fig. 1-6 means that

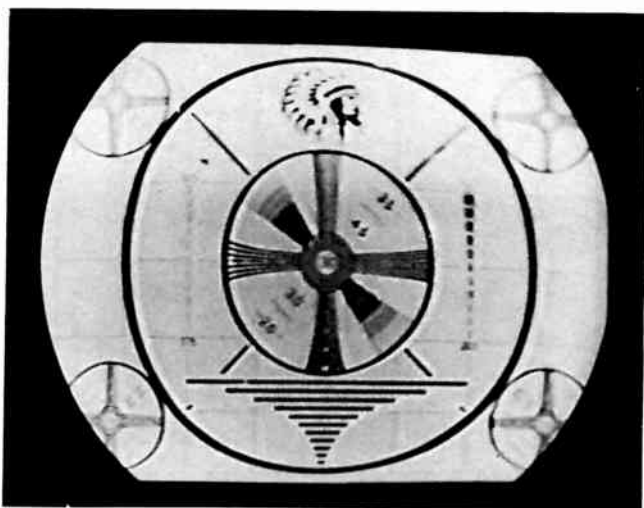

Fig. 1-6.—This pattern shows poor response at both low and high frequencies.

neither the low frequencies nor the high video frequencies are correctly amplified. The particular way in which a test pattern differs from normal indicates either some certain trouble or else any of a relatively small group of possible troubles. All such variations will be considered in due time.

A good raster is of uniform appearance, and fills the mask open-

ing, as in Fig. 1-2. A poor raster is unevenly illuminated, ragged, or has irregular outlines. The raster is absent when the screen cannot be illuminated by adjustment of brightness and contrast controls. Sound which is good, poor, or absent needs no explanation.

Now let's assume that our preliminary observations have indicated trouble in some one section or in any one of two or three sections. We might proceed at once with voltage measurements and various circuit checks in all suspected parts, but usually it saves time to use the oscilloscope for observation of frequency responses and waveforms in whatever stages are most likely to be in trouble.

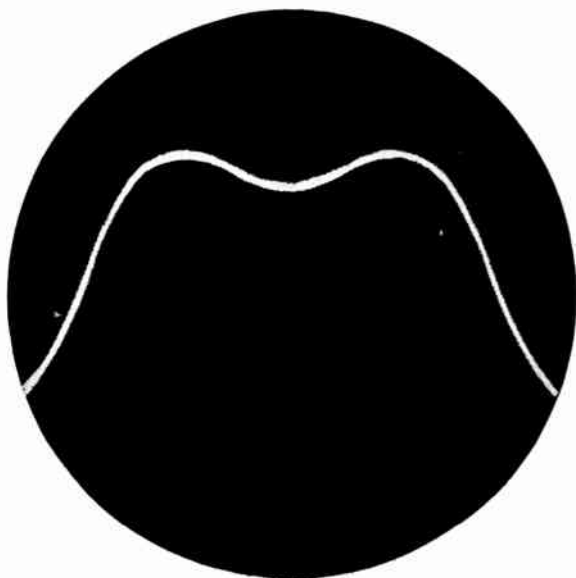

Fig. 1-7.—Typical normal response of circuits between antenna and output of the mixer.

In the tuner section we are dealing with modulated carrier frequencies of fifty to several hundred megacycles. Between the output of the mixer or converter and the input to the video detector we are dealing with modulated intermediate frequencies usually ranging from twenty to thirty odd megacycles. In these sections we are interested in frequency responses which show gain

8 APPLIED PRACTICAL RADIO-TELEVISION

or signal strength at all or nearly all the frequencies in a channel, or at the corresponding intermediate frequencies.

Fig. 1-7 shows a typical normal response for a tuner section or front end. Fig. 1-8 shows a normal response curve for a video i-f amplifier. Departures from curves which are normal for a receiver can give direct indications of the kind of trouble and of the stage in which it exists.

These curves of frequency response are used for locating troubles and making alignment adjustments in the tuner, the video i-f amplifier, and as far as the output of the video detector. For circuits between antenna input and sound takeoff these curves



Fig. 1-8.—This response would be normal for a certain type of video i-f amplifier, from mixer to video detector.

will cover the entire 6 megacycles of a channel, for in these sections we have both video signals and sound signals. Beyond the sound takeoff the response need cover only the video band, which varies from 3 to more than 4 megacycles with various receivers.

Input signals for producing curves of frequency response on the oscilloscope must be provided by signal generators, sometimes

by a single-frequency generator but more often by a sweep generator and marker generator used together.

Beyond the video detector we no longer have the carrier or intermediate frequencies, but only their modulation—which is the television signal itself. This signal includes the variations which produce lights and shadows of the picture, also the

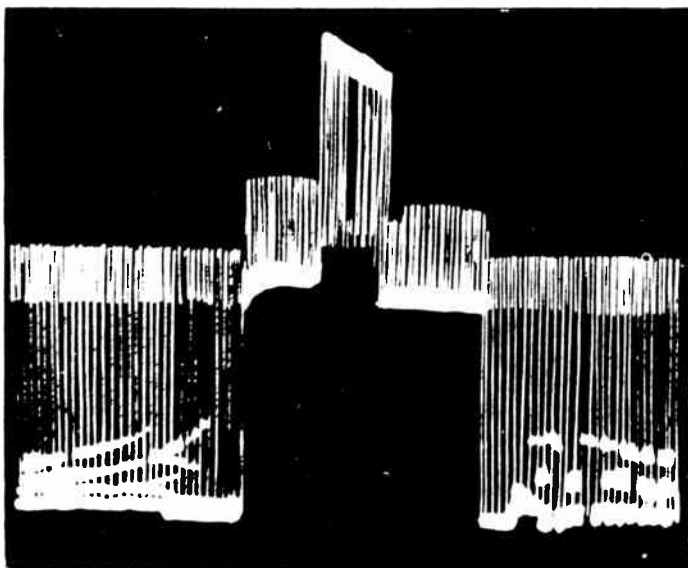

Fig. 1-9.—A trace of this type shows picture and sync signals in the video amplifier. (Courtesy of Admiral Corp.)

highly important pulses for synchronization and blanking. To observe the sync pulses on the oscilloscope we need no signal generator, but only a regular television signal as ordinarily received from any station.

Waveforms of sync signals, before and after modification, are observed along two paths. One path extends from the output of the video detector to the input for the grid-cathode circuit of the picture tube. Fig. 1-9 shows a normal waveform taken in a video amplifier. The other path extends from the sync takeoff all the way through the sync and sweep sections to the picture tube deflection circuits. Fig. 1-8 shows a normal waveform observed in the circuit of a sweep oscillator. Variations from normal wave-

10 APPLIED PRACTICAL RADIO-TELEVISION

forms indicate trouble, usually give definite clues as to its kind, and locate the fault in a particular stage or circuit by suitable connection of the oscilloscope leads.

By the time we have watched the picture tube, listened to the loud speaker, and made frequency response and waveform checks with the oscilloscope, the trouble will have been traced down to some small portion of the receiver—assuming that only one trouble is present. Then, in this one portion, it is in order to measure voltages and resistances, and to make tube substitutions, to definitely locate the troublesome part and determine what is wrong with it.

The experienced technician usually makes also the series of checks which would be applied to any radio apparatus in trouble. Here they are:

1. Examine the power outlet or wall receptacle, the plug, and the service cord from plug to receiver.
2. Examine connections of the transmission line at receiver terminals, and at the antenna if it is accessible.
3. Operate tuning controls on several channels to see that they act smoothly and uniformly. Try adjustments of any other front-panel controls, those which are accessible to the user.

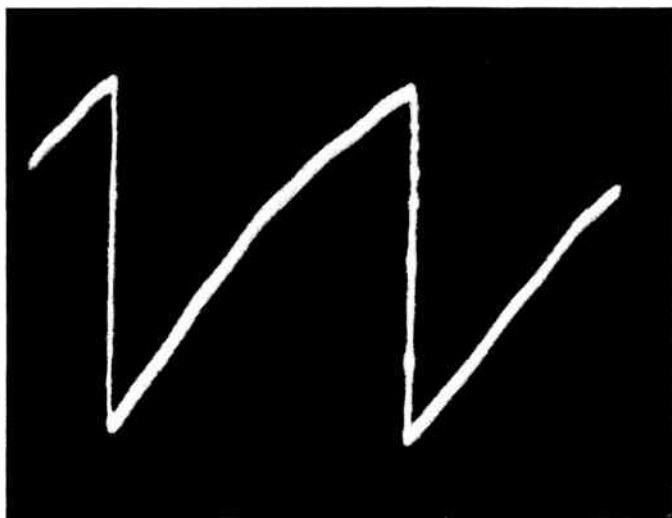

Fig. 1-10.—This trace shows the output of a vertical sweep oscillator.
(Courtesy of Motorola Inc.)

4. See that all tubes are lighted, that metal tubes are hot.
5. Lightly tap the tubes to determine whether any of them are microphonic and cause decided changes in the picture or pattern.
6. Examine chassis wiring for evidences of overheating due to shorts or grounds. Look for charring, burnt odors, melted joints, and so on.
7. With an insulated rod, lightly tap and press on terminal and wiring connections to determine whether any are loose and making poor contact. Wires or leads must not be moved out of their original positions during these checks.

With the general method of trouble shooting which has been outlined we may avoid spending time on sections which are not at fault, concentrate first on those sections most likely to be causing trouble, and later work on the less likely points in order. Keep in mind that no system of this kind can be infallible. It is based on probabilities. On any one job the systematic checking might prove slower than making a lucky guess as to the seat of trouble, or slower than some method based on experience with a particular receiver. They all have their own special troubles. But the time per job, averaged over a great many cases of trouble shooting, will be less than needed for any "hit or miss" plan.

The Television Signal.—To understand what happens to the television signal as it progresses through the receiver it is necessary to keep in mind the characteristics of this signal, which usually are represented as in Fig. 1-11. The time covered by this graph begins at the upper left with four of the picture signals and the intervening horizontal sync pulses occurring just as one field ends at the bottom of the raster or the bottom of the picture. After the last picture signal there begins the vertical blanking period, during which is the vertical retrace. In this period we have, first, six equalizing pulses occurring at half-line intervals. Their purpose is to permit correct interlacing, with alternate fields starting at the upper left-hand corner of the raster and at the top center.

Then come six vertical sync pulses whose purpose is to keep the vertical sweep oscillator in time with the received signal by starting the vertical retrace at the correct instant in relation to the picture fields. Following the vertical sync pulses are six more equalizing pulses. Between the last equalizing pulse and the fol-

lowing horizontal sync pulse the interval is only that for a half-line, as required for interlacing. In the remainder of the vertical blanking period there are regular horizontal sync pulses which keep the horizontal sweep oscillator synchronized with the signal. At the right-hand end of the upper graph are four of the picture signals and horizontal sync pulses which start the next field as the beam moves downward from the top of the raster.

The completion of this second field, at the bottom of the raster,

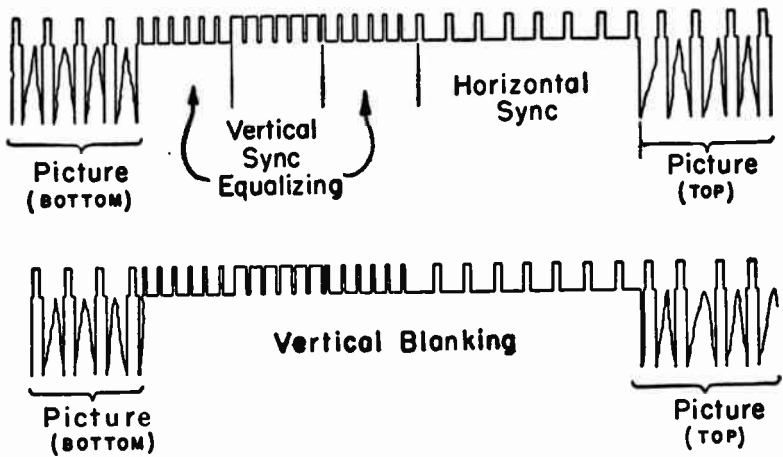

Fig. 1-11.—Here are represented the several kinds of modulation which form the composite television signal.

is represented by the three and one-half picture signals and four horizontal sync pulses at the left-hand end of the lower graph. Ending on a half-line is necessary for interlacing. Then comes another vertical blanking period with the same kinds and numbers of sync pulses as before, but with a full line rather than a half-line interval following the last equalizing pulse. At the right-hand side of the lower graph is the start of the following field, with a half-line at the top of the raster. This field ends at the left-hand side of the upper graph, and so the action continues.

This composite signal is the modulation of the television carrier. The modulation is transferred to the intermediate frequency in the mixer or converter, and separated from the intermediate frequency by the video detector. Maximum signal voltage is at the top of the graphs, zero voltage at the bottom.

Signal voltages are applied to the grid-cathode circuit of the picture tube in such a way that the higher the signal voltage the less becomes the intensity of the electron beam and the darker is the picture. Bias in the grid-cathode circuit causes complete cutoff of the beam when signal voltage rises to the value called *black level*. Then there is no illumination of the screen, it is black. This black level voltage is called also the *blanking level* or blanking voltage, since it makes the picture blank. All voltages higher



Fig. 1-12.—This is the portion of the television signal which produces pictures.

than the black level keep the beam cut off or blanked, and keep the screen dark. These higher voltages are used for synchronizing, not for picture production.

White areas or lightest tones in the picture are produced when the signal voltage drops to the value called *white level*. Any voltage between this value and zero will leave the picture white. Signal voltages having values between the black and white levels produce intermediate shades of gray in the picture.

The tops of the sync pulses have maximum signal voltage or 100 per cent voltage. The black level is at approximately 75 per cent of maximum. The white level is at approximately 15 per cent of maximum. All intermediate tones are produced by voltages between 15 per cent and 75 per cent of maximum.

The entire composite signal goes all the way through the tuner, the video i-f amplifier, video detector, and video amplifier to the input circuit of the picture tube. Here the grid-cathode bias causes cutoff at the black level. Intensity of the beam then is affected

by only the portion of the signal in which voltages are below the black level. This portion is shown by itself in Fig. 1-12. Cutoff or separation of the signal is at the black level.

We have been examining a signal with which relatively high voltages at the black level must reduce the intensity of the electron beam in the picture tube, while low voltages at the white level must increase the beam intensity. This is done, as at the left in Fig. 1-13, by applying the signal voltages to the cathode instead of to the control grid of the picture tube, and holding the grid at a fixed voltage.

The biasing voltage maintains the grid negative with reference to the cathode, or maintains the cathode positive with reference to the grid—whichever way we wish to consider it. With the signal applied to the cathode, as shown, the highly positive black-level voltages make the cathode much more positive. The result is an increase of voltage difference between cathode and grid,

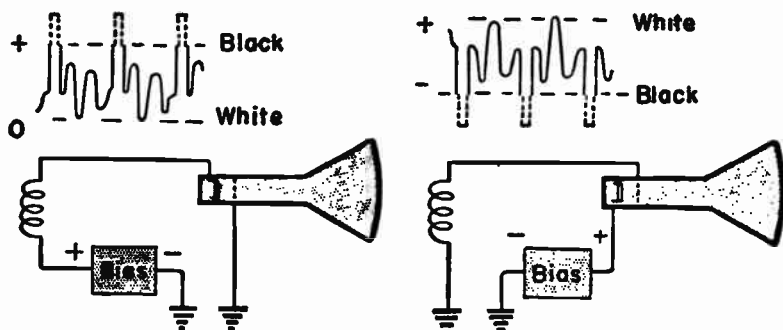

Fig. 1-13.—The television signal may be applied either to the cathode of the picture tube (left) or to the control grid (right).

with exactly the same effect as making the grid much more negative. This, of course, reduces the beam current and darkens the picture. On the other hand, the less positive voltages of the white level make the cathode only slightly more positive than the bias voltage, which is the same as making the grid only slightly more negative. This allows relatively large beam current and produces a bright area in the picture.

If the signal is to be applied to the picture tube grid rather than to the cathode, as in the right-hand diagram, the signal first must

be inverted in polarity. That is, the white level must be made the highly positive side and the black level the less positive side of the signal. The polarity of this or any other signal is easily inverted by passing it through a triode or pentode tube. In any tube having a control grid and a plate, the polarity of signal voltages in the plate circuit is opposite to their polarity as applied to the control grid circuit. We shall have more to say about all this when discussing video detectors and amplifiers.

Returning once more to our original signal, this entire signal goes not only to the picture tube but also to the input for the sync section. Tubes in the sync takeoff and other parts of the sync section are operated with such voltages and biases as to cut off the picture side of the signal and leave only the synchronizing portion shown separately in Fig. 1-14. Again the separation is made at the black level.

Signals such as shown by Figs. 11, 12, and 14 are those from which originate the waveforms observed on the oscilloscope when this instrument is used anywhere between the video detector and picture tube grid-cathode circuit. They originate also the wave-

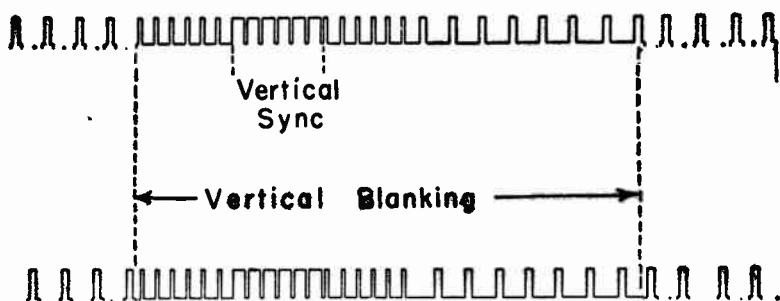

Fig. 1-14.—This is the portion of the television signal which synchronizes travel of the picture tube beam with the picture signals.

forms observed with the oscilloscope used anywhere in the sync section or in the sweep section of the receiver.

Television Frequencies.—The highest frequency in the demodulated television signal is the video frequency which corresponds to changes between lights and shadows along one of the active trace lines which form the picture. In the transmitted signal this

video frequency reaches a maximum of 4 mc (megacycles). If a receiver is capable of handling this maximum frequency there will be about 210 complete cycles during the 52.7 microseconds of a horizontal trace. Were this horizontal trace to consist of alternate uniform areas of black and white there would be about 210 of each shade. On a 12-inch picture tube with a raster $10\frac{1}{2}$ inches wide, each black or white area would be about $\frac{1}{40}$ inch long. No smaller detail should be reproduced or "resolved." On a 7-inch tube, with a raster only 6 inches wide, each alternate black or white area still could be $\frac{1}{40}$ inch long with a video frequency of only about $2\frac{1}{4}$ mc.

The lowest frequency in the television signal is the field frequency, the rate at which successive fields occur. There are 60 fields per second, two for each frame, so this lowest frequency is 60 cycles per second. Should we wish to observe on an oscilloscope the waveform produced during a single field, the sweep rate of the oscilloscope would be set for 60 cycles. To observe two fields or one complete frame on a single trace the sweep rate would be made 30 cycles.

Television Channels.—To accommodate the full 4-mc video frequency with double sideband transmission, as used in sound broadcasting, each channel would have to extend through 8 mc plus something extra for sound and for separation from adjacent channels. But television broadcasting, including sound, is carried out in channels only 6 mc wide by using *vestigial sideband transmission*, illustrated by Fig. 1-15. This graph shows relative strengths of radiated powers or voltages at various frequencies higher and lower than the carrier frequency.

With vestigial sideband transmission there is an upper sideband extending in full strength to 4 mc higher than the video carrier frequency, then falling to zero. There is a lower sideband extending to only $\frac{3}{4}$ mc below the video carrier frequency in full strength, and then falling to zero. At $\frac{1}{2}$ mc above the limit of full strength in the upper sideband, and $4\frac{1}{2}$ mc above the video carrier, is the sound carrier frequency. Sound is transmitted with frequency modulation in a band having a total width above and below the sound carrier of only two or three hundred kilocycles, or only 0.2 to 0.3 mc. To prevent interference with and from adjacent channels the sound carrier is placed $\frac{1}{4}$ mc below the

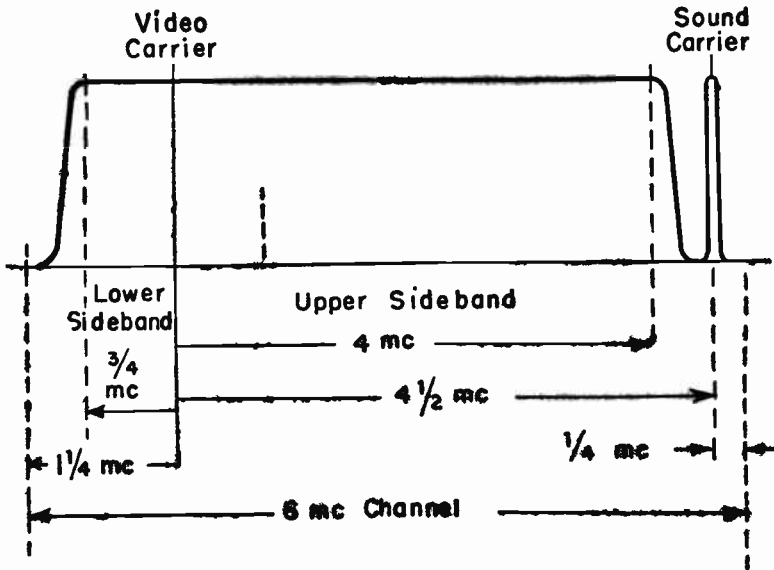

Fig. 1-15.—Distribution of frequencies in one channel with vestigial sideband transmission.

high-frequency limit of the channel, and there is an extra $\frac{1}{2}$ mc below the full-strength portion of the lower sideband.

Note that in the lower sideband are transmitted in full strength all modulation frequencies in the range between the video carrier and $\frac{3}{4}$ mc below it. These same modulation frequencies are transmitted also in full strength by the first $\frac{3}{4}$ mc of the upper sideband, the portion just above the video carrier frequency. Thus all modulation frequencies in this $\frac{3}{4}$ -mc range are transmitted with double strength. All the higher modulation frequencies are transmitted by only the upper sideband, consequently with only single strength. These different strengths which appear in the received signal are evened out in the video i-f amplifier, as will be shown when we come to the subject of receiver attenuation.

The graph representing vestigial sideband transmission is not a waveform, because it does not show changes of voltage with respect to time. Rather it shows only maximum permissible radiated powers or voltages with respect to the various frequencies included in a channel.

If a station were to transmit a range of carrier frequencies just as shown by Fig. 1-15, without modulation of any kind, this transmission could produce in a receiving antenna the same uniform voltage throughout the $4 \frac{3}{4}$ mc of the upper and lower sidebands. Such a signal would be excellent for service tests, for by observing the output of various stages between antenna and video detector we might tell whether or not there were uniform amplification or gain at all the frequencies.

The actual transmitted signal undergoes continual changes of voltage and frequency due to the modulation for pictures, blanking, and sync pulses. It is not constant enough nor uniform enough for testing. Consequently, for service work in stages carrying carrier and intermediate frequencies, we must use an instrument which will deliver an ideal input signal consisting of a voltage which remains constant while swinging back and forth through a range of frequencies 6 mc or more in width. This instrument is the sweep generator.

Chapter 2

TELEVISION SERVICE INSTRUMENTS

When the tuner of a television receiver is adjusted for some certain channel all the frequencies for both video and sound transmission in that channel should be amplified, while frequencies outside the channel should not be amplified. The amplification or gain for a certain tuner adjusted for channel 5, as an example, might be about as shown by the full-line curve of Fig. 2-1. The ranges of video and sound frequencies in the channel are shown by the broken-line curves. The gain curve, usually spoken of as the response, extends over all transmission frequencies in the channel, but not into adjacent channels.

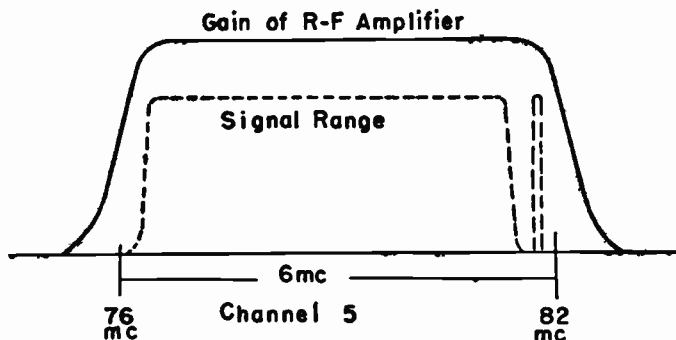

Fig. 2-1.—A gain curve or response curve for a tuner set for reception in channel 5.

It would be possible to check or measure the response of a tuner by coupling an ordinary signal generator to the antenna terminals and connecting an electronic voltmeter or other suitable indicator to the output of the mixer or converter circuit. Were the frequency from the signal generator slowly varied through the entire 6 mc of the channel, the output indicator would show the relative gain or response at every frequency in that channel. We could make notes of the relative gains at many frequencies and draw a response curve accordingly. This would be a time-consuming

process. Worse, it would be necessary to plot a new response to show the effects of every change in alignment adjustments or other service operations.

The practical method of observing a response is to have it appear continually on the screen of an oscilloscope, with every change of gain at any or all frequencies instantly indicated by a corresponding change in the trace. This is done by using a sweep generator instead of an ordinary signal generator for the input, and using an oscilloscope instead of a meter as output indicator.

A sweep generator is a signal generator whose frequency continually and automatically shifts back and forth through a range of several megacycles above and below some center frequency for which the generator is tuned. The width of sweep, which is the number of megacycles through which there is continual variation, is adjustable to whatever range is required to more than cover the channel on which you are working. For example, with a sweep generator adjusted for channel 5 its frequency might be made to sweep back and forth between 74 and 84 mc as shown by Fig. 2-2.

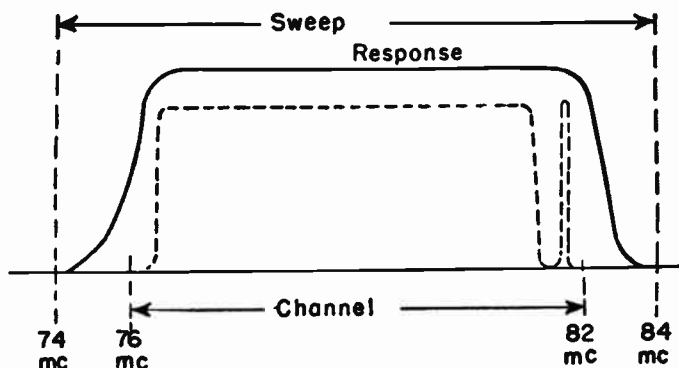

Fig. 2-2.—The frequency from the sweep generator shifts back and forth over a range somewhat greater than that of channel frequencies.

This sweep would extend from 2 mc below the lower limit of the channel all the way through to 2 mc above the upper limit.

In the next few pages we shall use frequencies in channel 5 to illustrate how some test instruments may be used. This will make it possible to talk about definite frequencies as specified in megacycles. It must be understood, however, that the same principles

would apply in all other channels with no changes other than in the particular frequencies mentioned.

The rate of sweep usually, but not always, is 60 times per second or 60 complete cycles of frequency change per second. Continuing with our example for channel 5, the frequency during $1/60$ second of time would change from 74 mc up to 84 mc and then go back to 74 mc. The change of frequency may be represented as in Fig. 2-3. This curve showing how frequency varies with respect to time looks like the familiar sine wave of alternating voltage. It actually is a sine wave because, nearly always, the rate of frequency sweep is controlled by an alternating voltage secured from the a-c power or heater circuits of the generator, wherein the frequency is 60 cycles or is the line frequency.

The output voltage of a sweep generator is adjustable by means of an attenuator control to any value between approximately

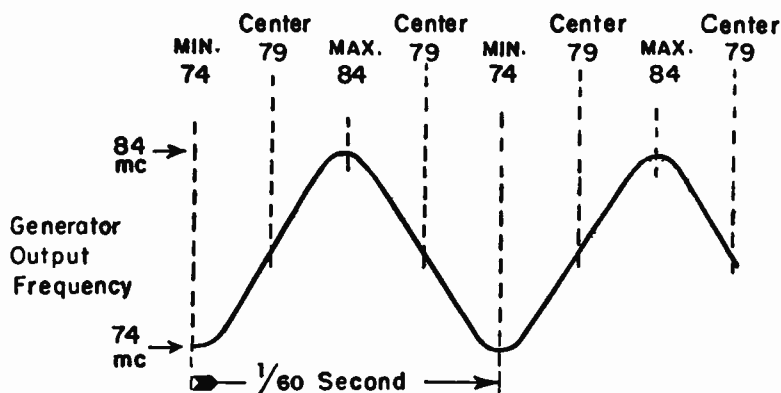

Fig. 2-3.—Variations of sweep generator frequency with respect to time.

zero and a considerable fraction of a volt. If this output is applied directly to the vertical input of an oscilloscope, with no amplifier in between, the vertical travel of the beam in the oscilloscope tube will be affected by the amplitude of the generator output voltage. The greater the output the greater will be the voltage tending to deflect the beam vertically. Horizontal deflection of the beam will be according to whatever voltage is used for horizontal sweep in the oscilloscope.

The name oscilloscope is such a long one that, hereafter, we

shall use the shorter word "scope" in referring to this instrument — as is general practice among service technicians. It may be mentioned also that the names oscilloscope and oscillograph are merely two different names for the same general kind of instrument.

An instructive experiment may be performed if the frequency from the sweep generator can be made low enough to come within the range amplified by the vertical amplifier in the scope. With service types of scopes the limit of vertical gain usually is no more than two or three megacycles, and may be much less. If the scope beam is being deflected vertically by the signal from the generator, adjustment of the internal sweep of the scope to 60

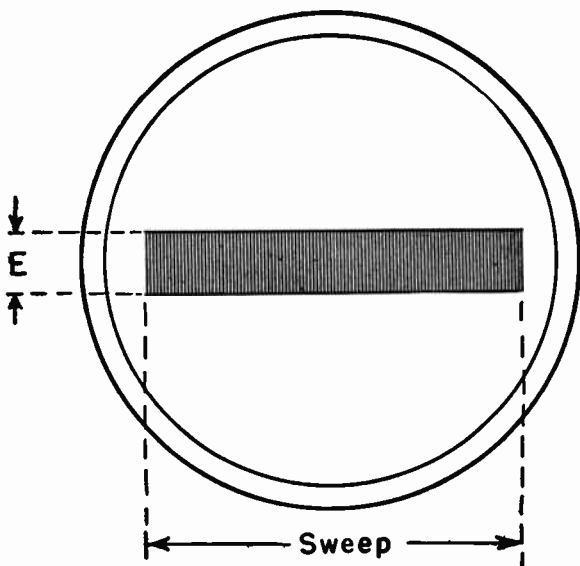

Fig. 2-4.—At very low frequencies the scope trace may show vertical deflection corresponding to sweep generator output voltage.

cycles will produce a trace somewhat as shown in Fig. 2-4. The height of the trace, dimension E , will vary with change of output from the sweep generator as the attenuator is adjusted.

At frequencies higher than those for which there is appreciable gain in the vertical amplifier of the scope, the trace will become

merely a horizontal line. This is because the beam no longer is moved up and down on the screen. Regardless of whether the trace has any height or is only a straight line, the frequencies are varying from one side to the other just as they vary during $1/60$ second in the output of the sweep generator. By adjusting the generator frequency to a small fraction of a megacycle you will plainly see how the vertical waves get closer together and farther apart as the frequency increases and decreases during the sweep.

Now we are ready to apply the output of the sweep generator to the input of a television tuner, as in Fig. 2-5, and connect the

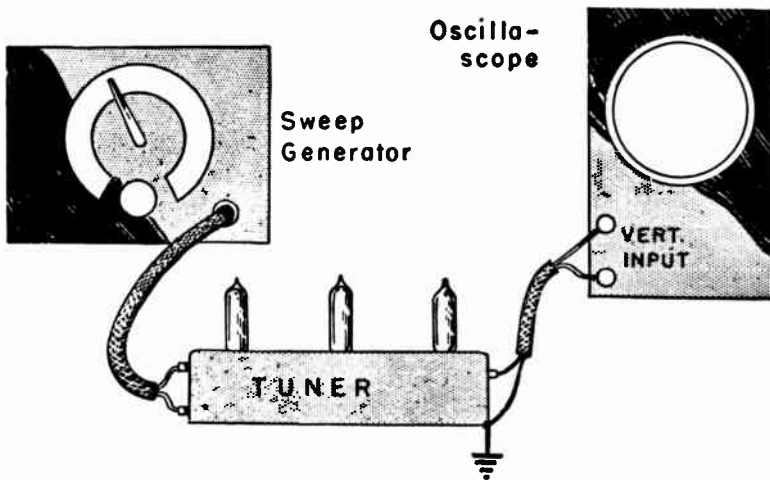

Fig. 2-5.—Voltage from the sweep generator is amplified in the tuner and applied to the oscilloscope.

output of the tuner to the vertical input of a scope. If the response or gain of the tuner is about as shown in Figs. 2-1 and 2-2, the trace will appear as in Fig. 2-6—provided the vertical amplifier in the scope has any gain at such high frequencies.

We are not particularly interested in the portion of this trace between the top and bottom outlines. It is only the upper outline and the lower outline which represent the response or gain of the tuner at the various frequencies in the swept range. The way to get rid of the high frequencies and leave only the response curve

on the scope screen is to demodulate the output of the tuner before it goes to the vertical input of the scope. This we may do by inserting between tuner and scope any detector which operates on amplitude modulation.

As you know, any a-m detector circuit does two things: First, it removes the high carrier frequency or the high intermediate frequency. Second, it delivers in its output only the average amplitude of the incoming frequency. As such detectors are ordinarily used in receivers, this average amplitude represents the signal modulation, but as we shall use the detector in our

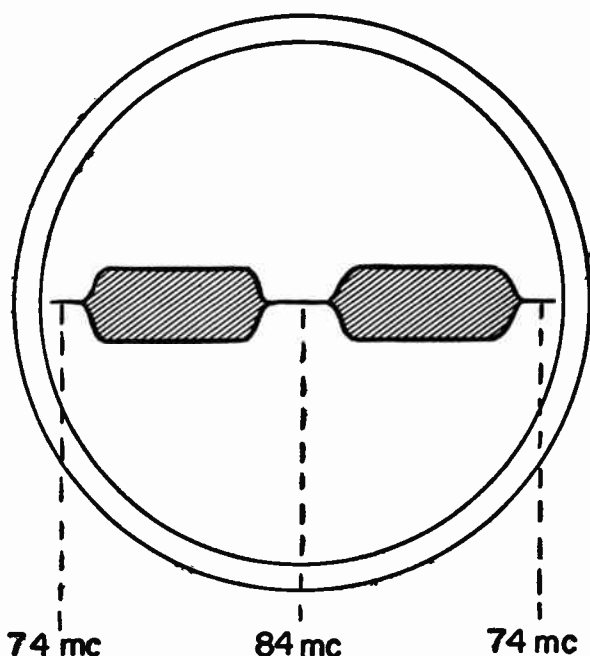

Fig. 2-6.—Amplification of generator output voltage occurs only at frequencies for which the amplifier has gain.

present work its output will represent the frequency response of whatever amplifier is connected between the signal generator and the scope.

Although we now are using a television tuner as the amplifier whose response is to be observed, exactly the same arrangement

of sweep generator, detector, and scope may be used for observations also on any one or more stages of the video or sound intermediate-frequency amplifiers. In fact, this combination of instruments may be used on any amplifying circuits which are between the antenna and either the video detector or the sound detector of a television receiver. In all these circuits there are carrier or intermediate frequencies.

When an oscilloscope is used on any circuits following the video or sound detectors of the receiver, those detectors will have removed the high intermediate frequencies and passed into their outputs only the signal modulations. Consequently, when working on circuits following either detector, we shall not need the extra detector about which we have been talking.

The modulation which passes into circuits following the video and sound detectors consists of audio variations, sync pulses, or both sync and picture signals—depending on where the signals appear. Most picture frequencies are beyond the gain limit of the vertical amplifier in ordinary scopes, but audio and sync frequencies are easily handled by this amplifier and will form signal traces on the screen of the scope.

Detector Probe.—Having talked so much about a detector for use with the scope it will be well to describe a typical unit such as may be purchased or assembled in the service shop. The circuit is shown by Fig. 2-7. The rectifier is a type 1N34 germanium crystal diode, which may be connected in either polarity. The only effect of reversing the positive and negative ends of the crystal will be to invert the response curve. With one connection

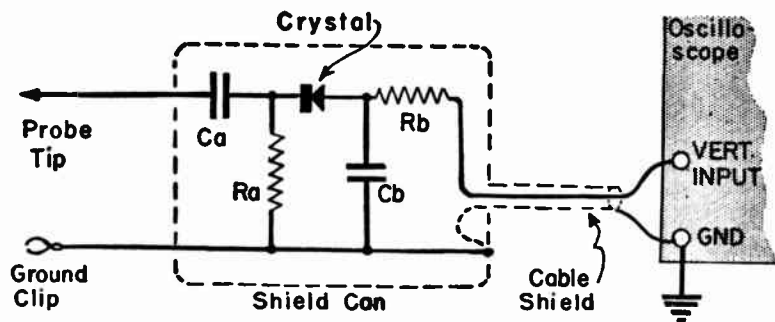

Fig. 2-7.—A detector probe using a crystal diode.

there will be produced the upper envelope of Fig. 2-8 and with the reversed connection there will appear the lower envelope. Capacitor C_a may have any value between 0.001 and 0.005 mfd. Capacitor C_b may be between 0.001 and 0.002 mfd. Both must be mica or non-inductive ceramic types. Resistor R_a may be of 10,000 to 20,000 ohms, and R_b of 5,000 to 20,000 ohms. Quarter-watt resistors are amply large in both places.

The entire unit must be enclosed in a non-magnetic metallic shield. Some shield cans made for small tubes may be adapted

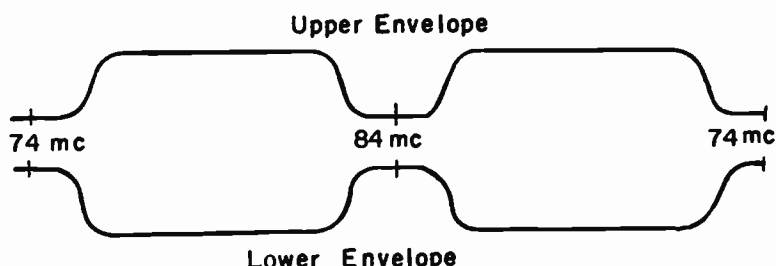

Fig. 2-8.—Either envelope may appear as the trace after demodulation.

to this purpose. The probe tip must be well insulated and mounted rigidly on or in the shield can. An insulated pin-jack tip is satisfactory, or a small insulated alligator clip may be used. Its outer end is protected with a rubber or plastic sleeve made for use with these clips.

Connection from probe to scope vertical input must be through a shielded cable. Small diameter single-conductor flexible microphone cable or any other flexible shielded conductor may be used. The shield of the cable is soldered to the shield can of the probe. Tip-jack plugs or other connections suited to the input terminals of the scope are attached to the opposite end of the cable. The ground clip should be a small alligator type on an insulated wire extending inside the shield can and soldered to this can. Since the high-frequency circuit is completed through the probe tip, capacitor C_a , resistor R_a , and the lead for the ground clip, this lead wire should be no longer than will allow its connection to chassis ground points near the place where the probe tip is being used.

Synchronized Sweep.—Now we may return to our observations of scope traces, where we had arrived at either of the two

response curves of Fig. 2-8. You will recall that these traces are secured with the internal sweep of the scope adjusted for 60 cycles.

Since the two curves are of like shape, and only one is needed during service operations, half the screen space is wasted by the second curve. By increasing the horizontal gain of the scope and at the same time shifting the horizontal centering control it may be possible to bring one enlarged curve onto the screen. There will be some distortion of the curve, because the variations of generator output frequency usually follow an approximate sine wave while the internal sweep of the scope should be nearly linear.

A method more generally used and one which, on the whole, is more satisfactory, makes use of a *synchronized sweep* voltage

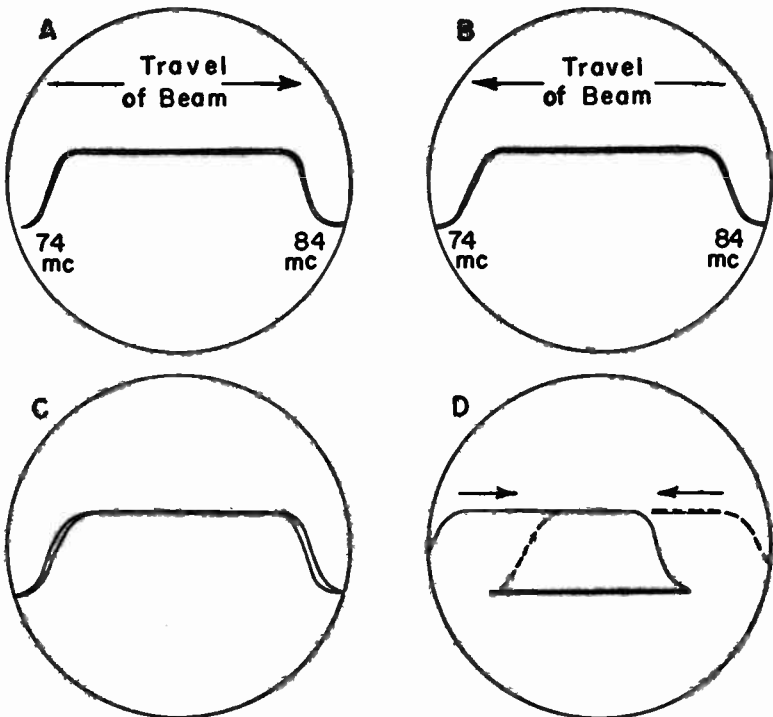

Fig. 2-9.—How forward and return traces are superimposed and synchronized.

instead of the internal sweep of the scope. Most sweep generators have provision for furnishing such a sweep voltage. It is an alternating voltage, ordinarily of the same frequency and always of the same waveform as the voltage which produces the frequency variation of Fig. 2-3. This sweep voltage is applied to the horizontal input of the scope to make the beam in the cathode-ray tube sweep horizontally in unison with variations of frequency.

With a 60-cycle synchronized sweep voltage used with a 60 cycle sweep rate, the electron beam moves from left to right and back to the left during each $1/60$ second. During the first half-cycle of sweep voltage the beam travels from left to right, as at *A* in Fig. 2-9, and the frequency changes from 74 to 84 mc with our apparatus set up for channel 5. During the second half-cycle, at *B*, the beam travels back from right to left, while frequency changes from 84 back to 74 mc.

Because of the rapidity with which they recur, both forward and return traces will be seen together as in diagram *C*. They may be exactly superimposed to look like a single curve or they may be displaced in greater or less degree with reference to each other. Slight displacement is illustrated in diagram *C*.

Phasing.—It is, of course, desirable that forward and return traces which actually are alike should appear as a single curve. They will appear so provided the synchronized sweep voltage actually is precisely in time with, or in phase with, the sweep of frequency. Otherwise the two traces may be greatly displaced, as in diagram *D*. Some sweep generators which provide a synchronized sweep voltage have this voltage truly synchronized or in phase with the variations of frequency. Other generators may have a phasing adjustment which will bring the traces together to appear as a single curve.

A sweep voltage which is adjustable as to phase may be secured from the 6.3 volt or 5.0 volt filament or heater circuit in the sweep generator. A circuit is shown by Fig. 2-10. One side of the circuit is grounded, as usually is the case with filament or heater circuits. Connections *H* and *G* may be made directly to the heater or filament winding of the power transformer, or *G* may be run to any ground point while *H* is run to the ungrounded heater or filament prong of any tube socket.

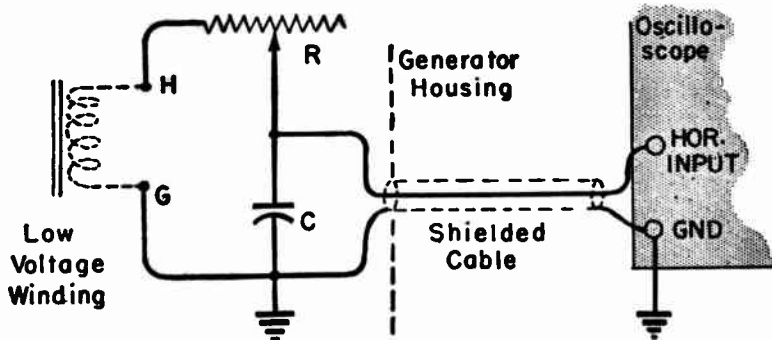

Fig. 2-19.—A circuit for phasing horizontal deflection in the oscilloscope with the sweep of frequency from the generator.

Resistor R is a potentiometer or rheostat of 50,000 ohms total resistance. Capacitor C may have a value of 0.02 mfd or more. A connection is made from between resistor slider and capacitor to the horizontal input of the scope through shielded cable. The end of the cable shield which extends into the generator housing is soldered to a chassis ground, while the other end of this cable shield is fitted with a tip for connection to the ground terminal of the scope.

As the slider of the resistor is shifted one way and the other, one trace or one curve on the scope screen will move to the right while the other one moves to the left. There will be one adjustment point with which the two traces or curves will come together. If they are alike, the two curves will appear as one.

Phasing circuits for the horizontal synchronized sweep may be built into the sweep generator or built into the oscilloscope. Both instruments are available with and without phasing controls. If neither is provided with such a control, a separate unit may be assembled by using any small transformer having a primary for connection to the power and lighting lines and a 5.0 volt or 6.3 volt secondary for use as the source of sweep voltage.

Requirements for Sweep Generators.—If a sweep generator is to be used for testing and alignment in all sections of the television receiver the generator tuning must be adjustable to any carrier frequency or any intermediate frequency which may be

encountered. Carrier frequencies in channels 1 to 6 extend from 44 to 88 mc, in channels 7 to 13 the carriers frequencies extend from 174 to 216 mc, and when higher channels are used, they too must be handled. Video and sound intermediate frequencies formerly lay in the range between 20 and 30 megacycles, but in some later receivers have extended upward toward 40 mc. In receivers using intercarrier sound systems the sound intermediate frequency is 4.5 mc. Some sweep generators care for these various ranges of frequency with separated bands, while others provide continuous coverage from less than 4 mc all the way through the high limit of the highest channel.

The frequencies just spoken of usually are called *center frequencies*. They are the frequencies above and below which there exists the sweep of several megacycles in extent. Most sweep generators have dials marked with graduations for all the center frequencies provided. The accuracy of frequency calibration need not be particularly good in a generator used only as a sweep. This is because the exact frequency at any or all points in the swept range is identified by means of a separate marker generator, which we shall discuss shortly.

The next consideration is the sweep width, which is the total number of megacycles through which the output frequency varies around the center frequency. When working on an entire channel it is necessary to have a sweep somewhat wider than the channel width of 6 mc. Intermediate amplifiers carrying both video and sound require the same width, and even when sound is not important or is not wanted in the response we still require ample sweep width to observe whether or not the sound is present. We may conclude that, for all work where video signals are present, the sweep width should be adjustable to a maximum of 8 to 10 mc. If the same sweep generator is to be used for visual alignment of sound it will be necessary to reduce the sweep width to around 2 mc at most.

The signal output of the sweep generator should be adjustable from a minimum of as near zero as possible through to a maximum of at least 0.1 or 0.2 volt, these strong signals often being needed when working with the amplification of only one stage. It is desirable, although not absolutely necessary, that the output be calibrated with a graduated scale marked in microvolts.

It is important that the output voltage remain practically constant as the frequency sweeps back and forth through any adjusted width and at any center frequency. If there are humps or dips in any swept range these irregularities will be amplified in the response curves and may completely obscure the true significance of such curves. If there is a slight rise or fall of output voltage through the swept range, and if the change is uniform from side to side of the trace, it may be allowed for and need not cause much difficulty.

If the sweep generator is to be connected to the antenna terminals of the receiver during any tests or adjustments it is highly desirable that the output impedance of the generator be reasonably well matched to the input impedance of the antenna terminals. Most receivers are designed for use with a 300-ohm balanced transmission line coming from antenna to two antenna terminals on the set. Neither of these is a ground terminal. Other receivers are designed for use with a 75-ohm unbalanced transmission line having a center conductor and an outer shield. Then there is one antenna terminal for the center conductor and a ground terminal for the shield of the line.

Sweep generators usually are designed with output impedances of either 50 or 75 ohms (unbalanced) or 300 ohms (balanced). Some have an output impedance which varies with attenuator adjustment from near zero to several hundred ohms. Generators often have arrangements for using either of two or more sets of terminals which allow different output impedances. In connection with the subject of tuner alignment will be shown some matching pads which may be used when there are no such provisions in the generator itself.

Marker Generator.—Although the sweep generator may be adjusted for any approximate center frequency and sweep width within the range of this instrument, it provides no means for identifying the exact frequencies at various points along the response curve. For such identification we need a second signal generator, called the marker generator. This is the type of signal generator in common use for all kinds of servicing, one which furnishes a single steady frequency determined by the generator tuning adjustment. A generator employed for a marker always is used without modulation, with a pure r-f output.

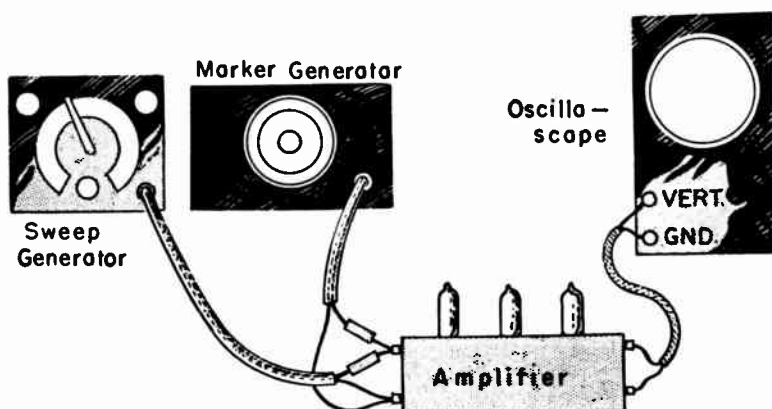

Fig. 2-11.—The sweep and marker generators are both connected to the amplifier input, with the oscilloscope on the output.

The chief requirement for the marker generator is precise calibration of its output frequency. The success or failure of many service operations depends on knowing, within a small fraction of one per cent, the frequencies at various points along the response curve. This accuracy depends on the marker generator.

As shown in principle by Fig. 2-11, the signal voltages from sweep generator and marker generator are fed together into any amplifier being tested. To illustrate what happens we shall assume a case in which the output of the sweep generator is varying between 74 and 84 mc, while the output of the marker generator is constant at 80 mc.

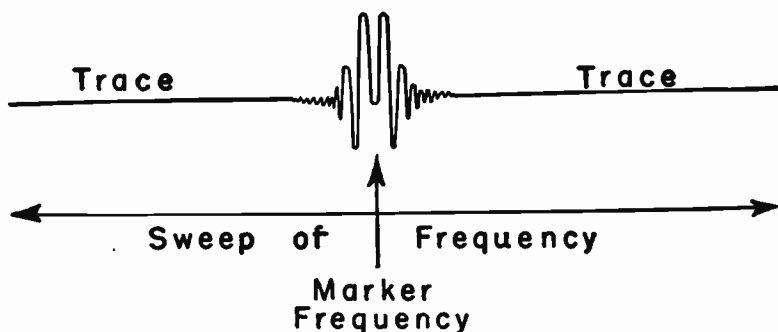

Fig. 2-12.—A marker produced by beating of frequencies from the two generators.

When any two frequencies are fed together into the same amplifier the frequencies beat with each other to produce sum and difference frequencies in the output. During each forward sweep and during each return sweep there will be some point on the response at which the frequency from the sweep generator passes through the same value as the frequency from the marker generator. In our assumed case this will be at 80 mc on the response curve.

At the instant of equal frequencies there is "zero beat." Just before and just after this instant of zero beat there are produced very low beat frequencies. These low-frequency beats will produce output amplitudes both greater and less than those existing at other instants. Fig. 2-12 shows, much enlarged, the result on the oscilloscope trace.

Such an irregularity on the trace is called a marker, a marker pip, or by some equivalent name. The center of the marker identifies the point on the response trace at which the frequency is that from the marker generator. Fig. 2-13 shows how markers appear at three different frequencies on the response curve of a video i-f amplifier. Each of these markers would exist when the

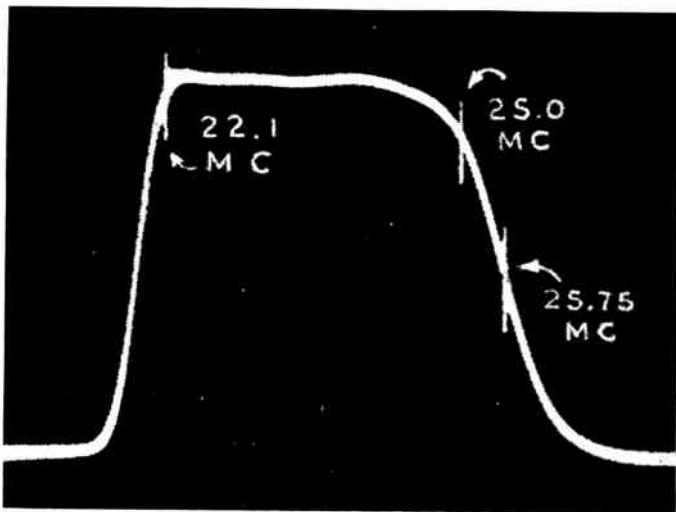

Fig. 2-13.—How markers may be made to appear on a response curve to identify various frequency points. (Courtesy of RCA)

marker generator is tuned to the frequency written on the figure.

In actual operation the center frequency and sweep width of the sweep generator are adjusted to bring the entire response curve, or as much of it as possible, onto the screen of the oscilloscope. Then, as the marker generator is tuned through the range of swept frequencies, the marker pip will move across the response curve. To determine the frequency at any point along the curve it is necessary only to bring the marker to the point in question and then read the frequency from the dial of the marker generator. To make the response satisfy certain requirements at some certain frequency, the marker generator is tuned to this frequency and left there while adjustments are made to shape the curve as may be required at the point identified by the marker pip.

Often the marker pip will be so wide as to make frequency identification rather difficult, or the trace may show many small vertical waves on both sides of the zero beat point. This is likely to happen when the vertical response of the oscilloscope extends to high frequencies, which appear in the beats either side of the zero beat point. The high frequencies may be bypassed and the marker pip made narrower by connecting a capacitor from the vertical input of the scope to ground. This capacitor may be located either at the scope input end of the cable or at the receiver or amplifier end. The required capacitance usually is something between 100 and 1000 mfd, with the correct value the least capacitance which gives a satisfactory pip. A carbon or composition resistor of 5,000 to 10,000 ohms in series with the vertical input lead may help to produce a narrower marker pip.

Requirements for Marker Generators.—As mentioned before, the first requirement for a marker generator is precision of frequency calibration. It is desirable that the frequency at or near important settings be compared with the output of some crystal controlled oscillator so that allowance may be made for any variation between actual frequency and dial indications of the marker generator. The range of frequencies should be the same as for the sweep generator. That is, the coverage should be of all the television carrier frequencies, of all the video and sound intermediate frequencies, and of the 4.5 mc intermediate for intercarrier sound.

Maximum output voltage should be at least 0.2 volt. There should be a good output attenuator, preferably calibrated in microvolts. It should be possible to use the output either unmodulated or else modulated. The percentage modulation should be known, or should be adjustable in known steps or with a calibrated dial. As with all test equipment, the output cable should be shielded, with the shield grounded. Usually, within the generator, there is a d-c blocking capacitor in series with the output lead. Otherwise it nearly always is necessary to use an external capacitor to prevent shorting of grid circuits to which the generator may be applied and to prevent getting direct current from receiver circuits into the attenuator system of the generator.

The Oscilloscope.—The diameter of the oscilloscope screen is of no particular importance other than for the fact that it may be easier to observe a response or a waveform on a large screen than on a small one.

When there is only moderate gain in whatever amplifier stages are between the signal generators and oscilloscope, the vertical amplifier stages are between the signal generators and oscilloscope, the vertical amplifier of the scope itself must have rather

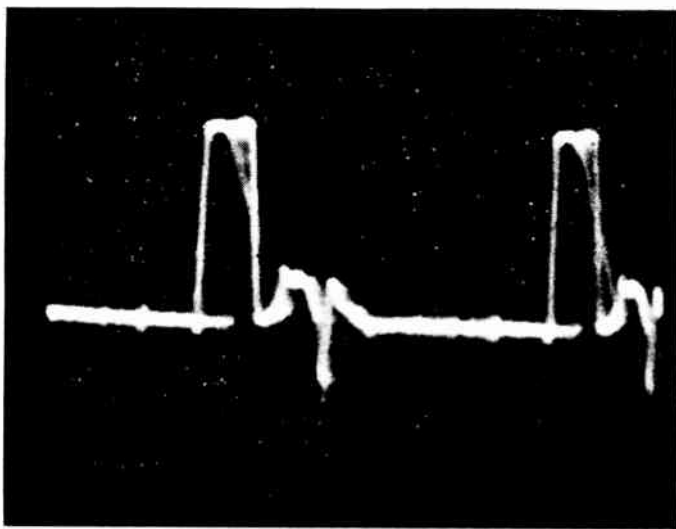

Fig. 2-14.—Sync pulses in the output of a clipper tube in the sync section.
(Courtesy of Motorola)

high sensitivity in order to produce a useful response curve. This will be the case when working through only the tuner or through only one or possibly two stages of the video i-f amplifier. The input from the sweep generator must be kept low in order that tubes in the amplifier won't be overloaded. For this class of work the vertical sensitivity of the scope usually has to be better than 0.1 volt per inch of deflection. If the generator signal passes through three or four stages of amplification before going to the oscilloscope, a vertical sensitivity of 0.5 volt per inch or even lower may be enough.

For measurements in parts of the receiver following the video detector a scope sensitivity of 0.5 volt per inch or even approaching 1.0 volt ordinarily will provide plenty of height on the traces. Here, however, we run into another requirement, that of frequency response in the vertical amplifier. Although the line frequency at 525 lines per frame is only 15,750 cycles per second, the square pulses of the sync signals consist electrically of combinations of many higher frequencies. To avoid extreme rounding of the corners or considerable tilting of the trace the vertical gain should be nearly flat up to at least 200 or 300 kilocycles, and preferably much higher. Fig. 2-14 shows a trace of horizontal sync pulses when using the internal sweep of the scope set for half the horizontal frequency in order to show two cycles or two picture line periods.

When the oscilloscope is being used on circuits following the video detector the purpose ordinarily is to observe sync pulses or to observe various waveforms in the sync section, the sweep oscillators, and the sweep output and deflection circuits. Often there are much higher frequencies which tend to make the traces appear fuzzy and to obscure the portions which are of

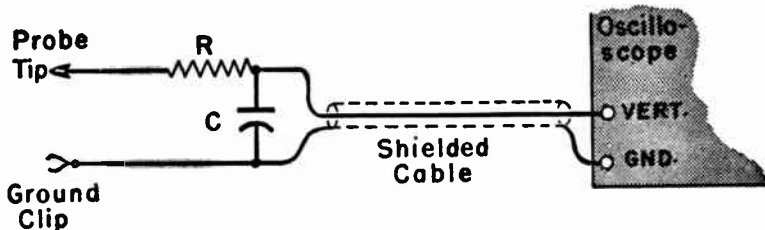

Fig. 2-15.—A low-pass filter probe for the vertical input of the oscilloscope.

real interest. To clear up the traces the vertical input cable should be fitted with a low-pass filter. A suitable filter circuit is shown by Fig. 2-15. Resistance at R may be anything between 8,000 and 15,000 ohms. Capacitance at C may be from 0.0005 to 0.002 mfd. The greater this capacitance the greater is the reduction or elimination of high frequencies, but too much capacitance will commence to cut out some of the lower frequencies which should be observed.

When using a sweep generator and a synchronized sweep for the oscilloscope a given trace or curve may appear on the screen in any one of the four positions shown in Fig. 2-16. Whether frequency increases from left to right or from right to left depends on the phase relation between the sweep voltage applied to the horizontal input of the scope and the voltage which causes shifting of frequency in the generator. Changing this phase relation by 180 degrees reverses the direction of frequency increase.

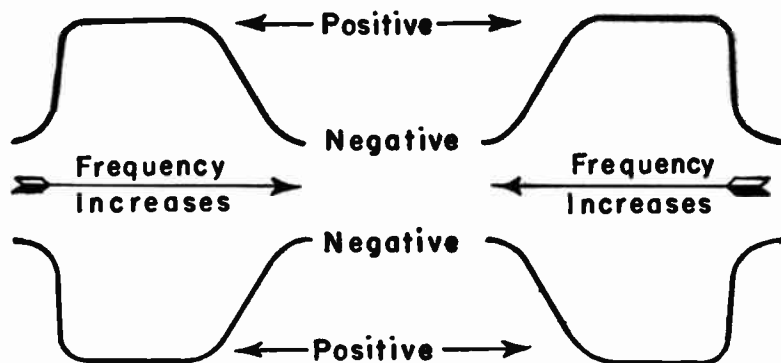

Fig. 2-16.—Responses and waveforms may be reversed and inverted in various ways as they appear on the oscilloscope trace.

If the source of synchronized sweep voltage is a unit separate from the sweep generator, reversing the position of the line plug in the power receptacle will reverse the direction of frequency increase.

Whether positive voltages are at the top or bottom of the trace depends, of course, on the polarity of the input signal and on the number of amplifying stages through which it passes be-

tween generator and scope. The signal in the plate load of every stage is inverted with reference to the signal applied to the control grid. This polarity depends also on the number of vertical amplifying stages in the oscilloscope and on the connection from the last stage to the deflection plates of the cathode-ray tube.

When observing sync pulses or other related waveforms the sweep generator and synchronized sweep voltage are not used. The beam of the cathode-ray tube is deflected horizontally by the internal sweep of the oscilloscope. The visible trace usually progresses from left to right with time, so that parts of a waveform occurring earlier are at the left, and those occurring later are at the right.

Whether sync pulses extend up or down from the black level depends on the polarity of these pulses at the vertical input of the scope. At various points throughout the sync and deflection circuits of the receiver the pulses are inverted as they pass through certain amplifiers, limiters and clippers. The polarity of the pulses depends also on the polarity of the vertical amplifying system in the scope, whether positive or negative input causes rise of the beam in the cathode-ray tube.

Often it is desirable to measure the voltage of a sync pulse or of the potential causing some other waveform trace with the oscilloscope used between the sync takeoff and the deflection circuits of the picture tube. Such measurements may be made with greater or less accuracy by applying to the vertical input of the scope another measured voltage which may be adjusted to give the same height of trace.

A method of making such voltage measurements is illustrated by Fig. 2-17. The power transformer is any small radio type from

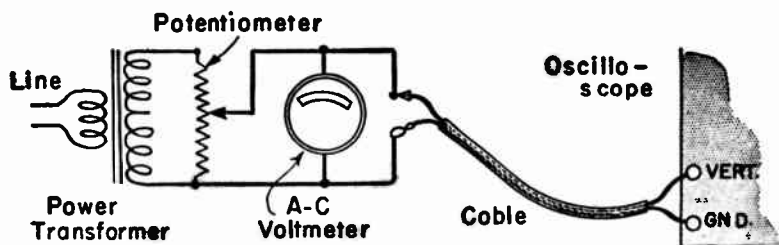

Fig. 2-17.—A unit for providing oscilloscope traces whose height may be translated into applied voltage.

whose secondary may be obtained 150 to 175 a-c volts. Across the transformer is a potentiometer whose resistance must be great enough that the current through it will not exceed the transformer rating, and whose own power rating will not be exceeded by the applied voltage and current. Between either end of the potentiometer and the slider is connected a high-resistance a-c voltmeter. A multi-range type of service meter is just right for this position. Across the voltmeter are connected any convenient terminals to which may be connected the ends of the cable being used for tests with the oscilloscope. It is necessary to use the cable between scope and meter because any filter resistors and capacitors will cause some change of voltage in the cable.

Waveform voltages ordinarily are specified in peak-to-peak values, from bottom to top of the trace. Because of capacitors which always are in series with the vertical input, the voltage causing deflection always is alternating. Peak-to-peak voltage then is twice the usual peak voltage value, which is measured from zero to either one peak. The ordinary zero-to-peak voltage in a sine wave is 1.4 times the effective value in the same wave. The meter used as in Fig. 2-17 indicates effective a-c voltages. As a consequence of all this, the voltage shown by the meter must be multiplied by 2 and then by 1.4, or multiplied by 2.8 to convert it into the equivalent peak-to-peak voltage of the scope trace. This explains why we need only 150 to 175 volts from the transformer secondary, for when multiplied by 2.8 this allows measuring peak-to-peak voltages of around 400 volts.

Voltages measured in the manner just described are being compared with those whose frequency is 60 cycles, the power line frequency. If the receiver frequencies are so high that the gain in the oscilloscope amplifier is lower than at line frequency the computed voltage values will be lower than the actual high-frequency voltages. It should go without saying that the vertical gain control of the scope must not be changed when transferring the input cable to the voltage measuring unit.

Electronic Voltmeter.—The overall response of the entire video i-f amplifier covers a range of from three to four or more megacycles. This broad range may be satisfactorily checked only with the sweep generator and oscilloscope. But the individual stages of many video i-f amplifiers have a relatively narrow response,

being peaked more or less sharply to a single frequency. By tuning several such peaked stages to different frequencies their combined or overall response covers the i-f range.

Peaked stages may be aligned one by one with the sweep generator and oscilloscope, but it's more common practice to employ a single constant frequency for the input. This steady frequency is furnished by an accurately tuned unmodulated signal generator, usually the same instrument used for a marker generator in other operations. The output is measured with an electronic voltmeter, whose reading becomes maximum when the stage is aligned to the input frequency, and falls off at either higher or lower frequencies.

Fig. 2-18 compares the response of a peaked stage as it would be shown by the oscilloscope and by the electronic voltmeter. As the signal generator is tuned through the frequencies for which

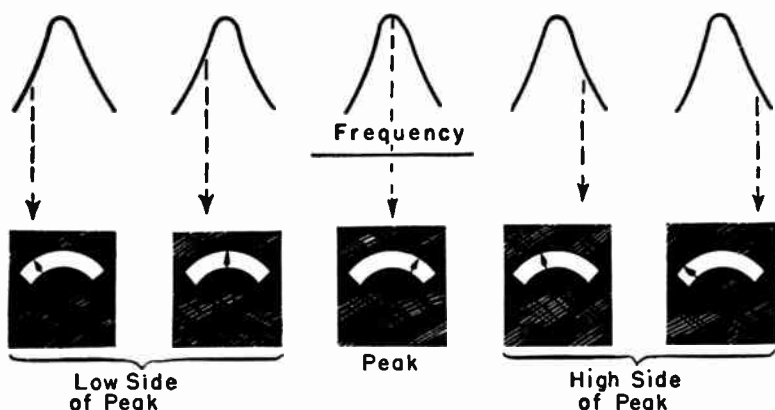

Fig. 2-18.—Indications of an electronic voltmeter follow the rise and fall of the oscilloscope trace.

there is gain in the amplifier the meter reading first will increase, will become maximum at the peaked frequency, then will decrease as the peak is passed. When the signal generator remains tuned to the frequency at which the stage should be peaked, the reading of the meter will become maximum when alignment is correct.

At the low output voltages which have to be measured it is necessary to use an electronic voltmeter rather than any other

type. This is because the input resistance or impedance of such a meter remains high even when used on the low voltage ranges. For measurements at radio frequencies the electronic voltmeter is used with a rectifier probe or detector probe quite similar to the one already described for use with the oscilloscope. The meter itself is primarily a d-c instrument, and must be fed through some kind of rectifier when alternating voltages are to be measured.

All probes have a certain amount of input capacitance which tends to detune the measured circuits. Then the voltage actually is being measured with the circuit tuned to the altered frequency. In well designed units this capacitance is made very small, and its effects are not serious when the meter is used according to instructions for the various tests.

Test Setups.—The television service instruments which have been described should be arranged on a shelf above and back of the work bench in some such manner as illustrated by Fig. 2-19. The most important feature here is the provision for grounding all the instruments and the receiver worked upon to the same body of metal. This grounding metal consists of a sheet of copper or aluminum covering the top of the shelf and another sheet covering the working surface of the bench. The two metallic

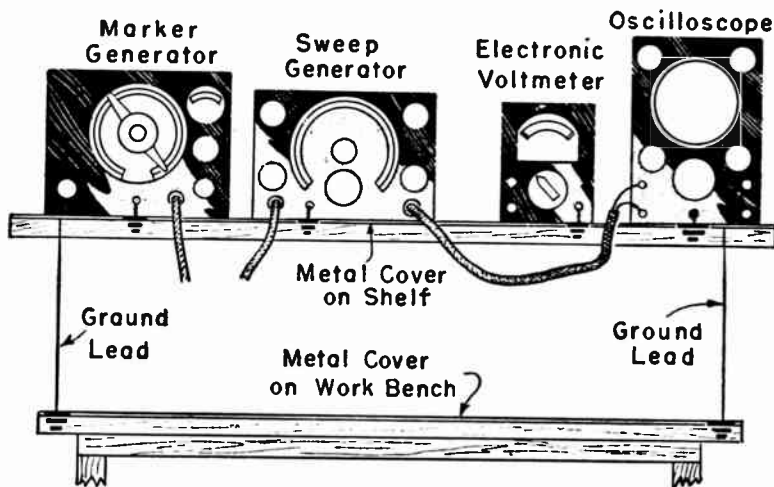

Fig. 2-19.—Service instruments on a shelf above the work bench.

sheets are joined together by heavy bonding leads at both ends.

Each of the instruments must have a connection from one of its ground terminals to the metal sheet. The receiver chassis will be grounded to the bench top by contact, but this is not enough. One or more ground connections should be made through flexible leads secured to the metal sheet by soldering or otherwise, and to the chassis with screwed connections or else good strong spring clips. When receivers having series heaters connected to line and chassis are worked on it is absolutely necessary that their power supply come through an isolating transformer. It is a safe plan to use such a transformer, with secondary insulated from primary, as the power source for all receivers which are serviced.

After everything is set up for making measurements and adjustments the reading on the electronic voltmeter or the trace on the scope should not be altered in the slightest degree as you handle various parts of the equipment. Any change in indications means that the grounding is not of low enough resistance or else is to the wrong places on the chassis.

The connection of the output of the sweep generator to the receiver usually is to the control grid of some tube. This connection should be made through a mica capacitor whose capacitance is no more than 20 mmfd and preferably less. Then the output lead of the marker generator is connected to the same point in the receiver circuits through a second equally small capacitor. This latter coupling sometimes is made by winding three or four turns of bare or insulated wire around the lead from the sweep generator, then connecting the marker generator output to one end of this wire. Sometimes merely laying the cable from the marker generator near the cable from the sweep will give enough input.

After the coupling from the marker generator has been arranged, and before the power switch of this generator is turned on, obtain a trace on the scope. Then disconnect the marker coupling. If there is any change in the trace it will be necessary to rearrange the ground connections to the chassis, or make more such connections.

Voltage Measurements.—In ordinary sound receivers of the home radio type the maximum potentials are on the order of a few hundred volts. If you accidentally touch a high-voltage point

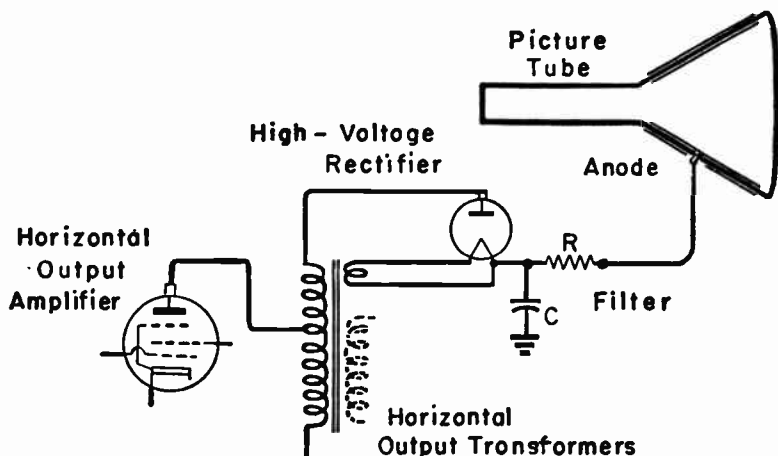

Fig. 2-20.—Circuits and parts which are at very high voltages with a "flyback" type of supply.

you get a rather severe jolt, but no great harm results. In television receivers some of the circuits associated with the picture tube carry thousands of volts. Accidental contact with a live circuit at such potentials may mean serious injury, and for those with heart ailments could be fatal. Consequently, we should become familiar with the safe handling of such circuits before proceeding to any actual service operations.

Fig. 2-20 shows in heavy lines the parts operating at high voltages in a typical system for a magnetic deflection type of picture tube. For a 10-inch picture tube the pulsating or steady voltages in these parts range from 4,000 to 9,000 volts, and with larger tubes the voltages go even higher. Note especially that even at the plate of the horizontal output amplifier the pulse potentials run between 4,000 and 6,000 volts.

With 7-inch electrostatic deflection tubes the maximum potentials usually are on the order of 5,000 volts, but these potentials reach more parts than do the high voltages in a magnetic deflection system. Fig. 2-21 shows the circuits for an electrostatic deflection tube in which potentials ordinarily range from about 1,500 volts at the focusing control and focusing anode of the picture tube, up to around 5,000 volts in the other parts. Note that

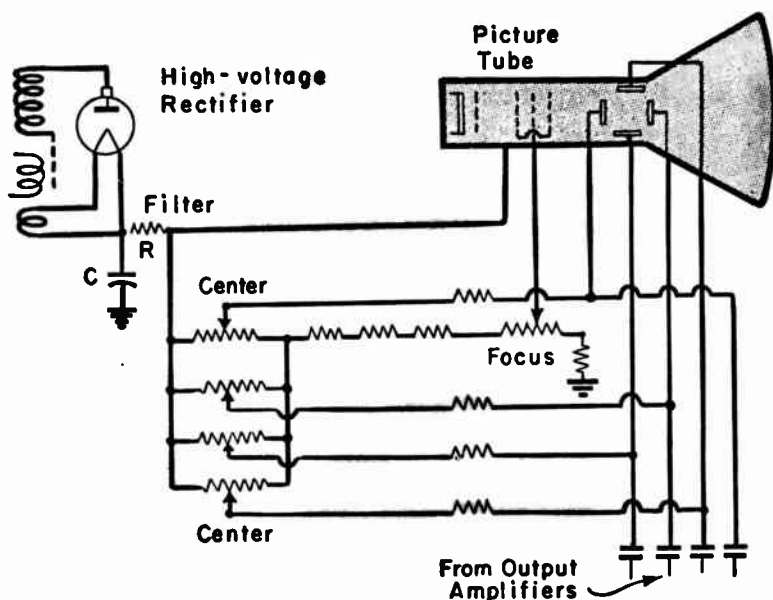

Fig. 2-21.—Circuits and parts at high voltage with an r-f voltage supply used with electrostatic deflection in the picture tube.

the horizontal and vertical centering controls are at the maximum voltage.

The first and most important rule is never to let any part of your body come dangerously close to any high-voltage parts while the circuits are operating, and never to make contact with any of these parts until after the cord plug has been withdrawn from the power line receptacle. Do not depend on merely turning off the receiver switch.

The charge of a filter capacitor C as in Fig. 2-21 quickly dissipates through the voltage divider resistances to ground. In the magnetic deflection system of Fig. 2-20 a high-voltage charge may be retained for a considerable time in the filter capacitor C and also in the capacitance formed by the inner and outer coatings of the picture tube with the glass between them as the dielectric. These capacitances may be discharged by attaching one end of an insulated wire to the chassis ground, then touching the other end of this wire to the high-voltage anode terminal on the picture tube. If this terminal cannot be reached without re-

moving the connecting lead, carefully take off the lead, then discharge the capacitor by touching the lead clip with the grounding wire, and discharge the tube capacitance by touching the anode terminal with the grounding wire.

Nearly all the recently designed receivers have high-voltage power supplies in which the rectified voltage is at either the horizontal scanning frequency of 15,750 cycles per second or else at some radio frequency greater than 100 kilocycles per second. These high frequencies require only small filter capacitances having small energy storage. In older receivers the rectified power supply voltage is at line frequency, just as in ordinary low-voltage B-supplies. Here the filter capacitances are relatively large, and can store enough energy to give dangerous shocks.

The high-voltage rectifier of Fig. 2-21, also its transformer and possibly other power-supply units usually are enclosed by a ventilated metallic shield. All the parts of Fig. 2-20, including the output amplifier, are enclosed within a similar grounded shield. Removal of the shield may open a safety interlock plug-jack arrangement or may open an auxiliary switch that cuts off the line power from the entire receiver. Otherwise an interlock may be opened by removal of the cabinet cover which gives access to the receiver.

The interlock must be jumpered or blocked closed in order to operate the receiver with the power supply shield removed or the cabinet opened, as the case may be. When working under such conditions make it an inviolable rule to pull the line cord plug before making any measurement connections, adjustments, or replacements in the high-voltage system. Then replace the cord plug in the receptacle to turn on line power while observing the results of any changes. But before making any further changes again pull the line power plug.

The safest way to connect voltmeters or other measuring instruments into the high-voltage supply is to tack solder the ground lead and use a spring clip for the other lead. Try not to use ordinary hand-held test prods. If prods must be employed use only those types which are insulated for ten or fifteen thousand volts, or whatever is needed, and which have finger guards. When using any hand-held test prod keep your other hand in a pocket or behind

your back and be sure you are standing on a well insulated floor, one which is not damp. Then a shock can force current through only the one hand, not through your body and vital organs.

Not many service type voltmeters are adapted for direct measurements of potentials in excess of 5,000 volts. For higher voltages it is necessary to use a special multiplying test prod such as may be furnished with the meter, or to fit an external multiplier to an ordinary moving coil type of high-resistance meter. To make such a multiplier it first is necessary to know the internal resistance of the meter for the voltage scale which will be used—ordinarily the highest available range of the instrument. Multiply the number of full scale volts by the number of ohms per volt of the meter. The result is the internal resistance in ohms.

To double the range of the meter connect in series a multiplier whose resistance is equal to the meter internal resistance. To triple the range, have twice the internal resistance as the multiplier resistance, for four times the range use three times the internal resistance, and so on. The full-scale current, in microamperes, taken by any moving coil voltmeter is found from dividing 1,000,000 by the sensitivity in ohms per volt. If the meter draws much more than 100 microamperes the added load on measured circuits will be enough to make readings quite inaccurate. This means that there is little use in working with a meter whose sensitivity is not at least 10,000 ohms per volt.

The multiplier should be assembled with eight to ten or more resistors soldered end to end as in Fig. 2-22. The resistors may be housed in an insulating cover and embedded in high grade insulating wax. Have the resistors strung out in order, or, at least,

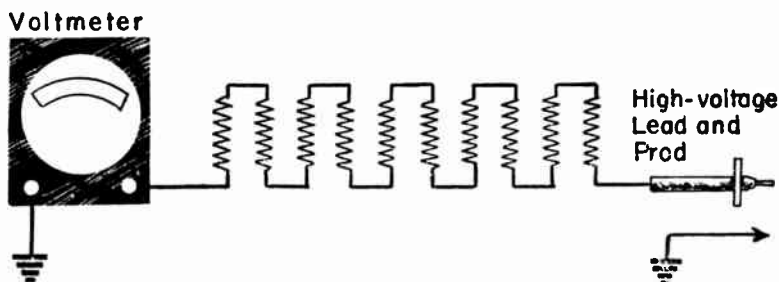

Fig. 2-22.—High-voltage multiplier assembled with resistors.

don't get the last ones right next to the first ones in the string. This avoids excessive voltage differences between adjacent resistors. Always connect the voltmeter into the grounded side of the measuring circuit.

Having computed the total resistance required in the multiplier, divide it by some number which allows using standard resistance values, then use this number of resistors of the indicated value. It may be necessary to use one resistor of smaller value to make up the total. To determine the required wattage rating of the resistors, square the highest voltage to be measured and divide the result by the total number of ohms in the multiplier string plus the meter resistance. Then divide the total watts thus found by the number of resistors, to be on the safe side, and this result is the actual wattage to be dissipated by each resistor. Use units whose rating is at least three or four times this actual dissipation, so they remain cool. All units, regardless of their resistance, should be of the same wattage rating.

If voltages are to be measured with an electronic voltmeter, make up a similar resistor string but use it as a voltage divider as shown by Fig. 2-23. The meter is connected across the last resistor at the grounded end of the string. Voltage computations

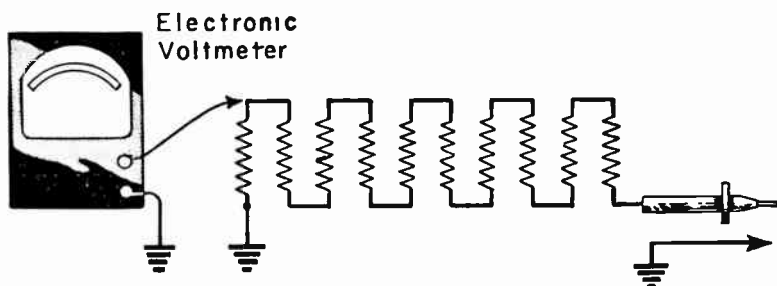

Fig. 2-23.—How a voltage divider is used with an electronic voltmeter.

will be more convenient if this last unit is of some even number of megohms, say 1 megohm or 2 megohms.

Here we are not directly concerned with the internal resistance of the meter, so must use other means for determining the resistance in the divider string. To determine the least resistance which may be used as a total proceed thus: Multiply the highest number

of volts to be measured by the number of ohms in the resistor across which the meter will be connected. Divide the result by the full scale of volts of the meter range to be used. Using more total divider resistance than given by this computation will reduce the current drain on the measured circuit, but will also reduce the portion of the meter scale which will be used when measuring the highest voltage. To use more of the meter scale and still reduce the current drain, use more resistance in the unit across which the meter is connected or else use a lower full-scale range of the meter.

To determine the value of voltage at the test prod or lead first divide the total resistance of the resistor string by the resistance of the unit across which the meter is connected. Neglect the internal resistance of the meter itself. Then multiply the result by the number of volts shown on the meter dial. This gives the measured voltage at the prod or clip.

Voltages are measured at plates, screens, control grids, and cathodes of tubes other than the picture tube in just the same way as such voltages are measured in any radio service work. This applies also to the control grid, the cathode, and other relatively low-voltage grids or anodes in picture tubes. As with all voltage measurements, the greater the internal resistance of a moving coil meter the more accurate will be the results. An electronic voltmeter gives more accurate results than any moving coil type. Service instructions of the manufacturer may state that voltages are measured with some certain type of meter, and to obtain equivalent readings the same type of meter must be used in servicing operations.

Unless specified otherwise, voltages are measured between socket terminals and ground on the chassis, or, with some series-heater receivers, between socket terminals and B-minus. It is assumed that the a-c line supply is at 117 volts. If the line voltage is higher or lower, or fluctuates, it is advisable to use a voltage regulating or adjusting transformer to obtain 117 volts. Service instructions may specify that controls for contrast, brightness, and other characteristics be in certain positions for voltage measurements. Otherwise all these controls may be in the positions ordinarily used for reception. The antenna or transmission line always should be disconnected from the receiver, and the

TELEVISION SERVICE INSTRUMENTS

channel selector set for some channel in which there is no transmission from stations within normal range of the locality.

Precautions During Servicing.—We all understand that there is inductance in even a short length of straight wire, and that there is capacitance between every two conductors separated by any kind of dielectric or insulation. These things are of minor importance at standard broadcast frequencies, other than that we may have unwanted coupling between long lengths if conductors run close together. But at the frequencies employed in television we have to develop great respect for short conductors, and try to keep away from long ones entirely, and we soon come to appreciate the effects of capacitance between parts which seem well spaced.

The position of every resistor, capacitor, and inductor in relation to all other parts may have and usually does have important effects on tuning when these units carry either carrier frequencies or intermediate frequencies. Since every conductor possesses inductance and at the same time has capacitance when considered in relation to all other conductors, it comes about that tuning may be upset by the least change even in the wires which complete various high-frequency circuits. You should not change the position of any wire in these circuits during service work.

When resistors, capacitors, or inductors have to be replaced, the safe method is to use only exact replacements. An exact replacement is the same not only in its electrical values, but must be of the same materials, of the same dimensions, and have the same kinds of connections as the original. When leads are replaced, the new ones must be of the same gauge of wire, with the same kind of insulation if any is used, and must be of the same lengths as the originals. Ground connections must be replaced at the original points, for the position of a ground usually determines the portion of the chassis metal through which circuits are completed. The center terminals of many miniature tube sockets are grounded and are used for ground connections from various circuits.

Don't remove any shields while making tuning or alignment adjustments; work through openings provided in the shields. If there are no openings, take off the shield and make an opening. Then replace the shield before proceeding. Some workers obtain

duplicate standard shields for receivers often serviced, make suitable openings in these duplicates, and use them while making adjustments.

Whatever the location of resistors, capacitors, and inductors leave them there unless the receiver has been incorrectly serviced by someone else. In general, all high-frequency parts are dressed away from chassis metal. This applies especially to coupling capacitors and peaking coils. Don't add new or extra parts anywhere near others already in the receiver high-frequency circuits. Don't switch tubes, even though they are of the same type and make, unless you are willing to realign the circuits.

Chapter 3

TELEVISION TUNERS

Before undertaking the actual work of alignment and other service adjustments in television receivers it is necessary that we understand principles of construction and operation which are in common use. We are especially interested in what might be called the mechanics of service rather than in radio theories, and it will be on this basis that we shall proceed. We may commence our examination where the television signals enter the receiver, at the tuner.

Television tuners make use of the same fundamental principles of the superheterodyne as employed in the r-f and oscillator sections of conventional sound receivers. That is, there is an r-f amplifier fed from the antenna through the transmission line, an r-f oscillator, and a mixer. Television receivers do not use the types of converter tubes which combine in a single electron stream and a single set of elements the functions of oscillator and mixer. Rather, these two functions are performed by separate tubes or else by two independent sets of elements in one envelope. In spite

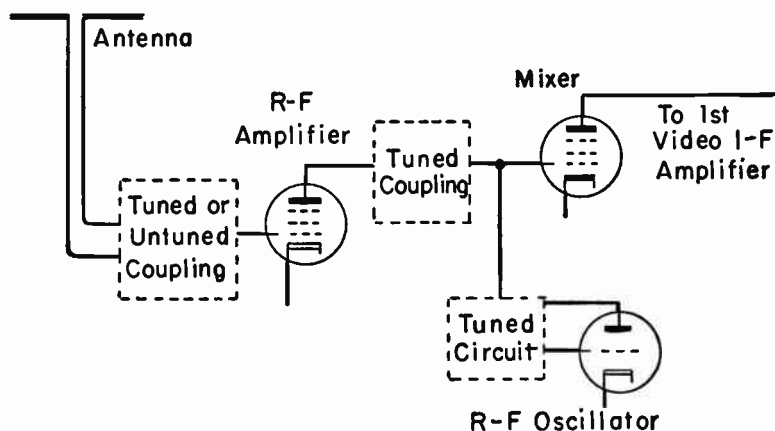

Fig. 3-1.—Where tuned circuits are found in a tuner section.

of this, the television mixer sometimes is called a **converter**, a **first detector**, a **modulator**, or some similar name.

There are various ways of making the tuner circuits resonant at the frequencies in any channel where reception is desired. Some general principles are illustrated by Fig. 3-1. The coupling between antenna and r-f amplifier sometimes is tuned and again may be untuned. The coupling between r-f amplifier and mixer always is tuned to the channel frequency. The oscillator "tank circuit" always is tuned to a frequency which differs from the r-f frequency by an amount equal to the intermediate frequency used in the receiver.

There are several different ways of changing the resonant frequency in whatever tuned circuits may be employed, so that they are responsive to any one channel. The method which probably is in most general use provides, for each channel, a separate

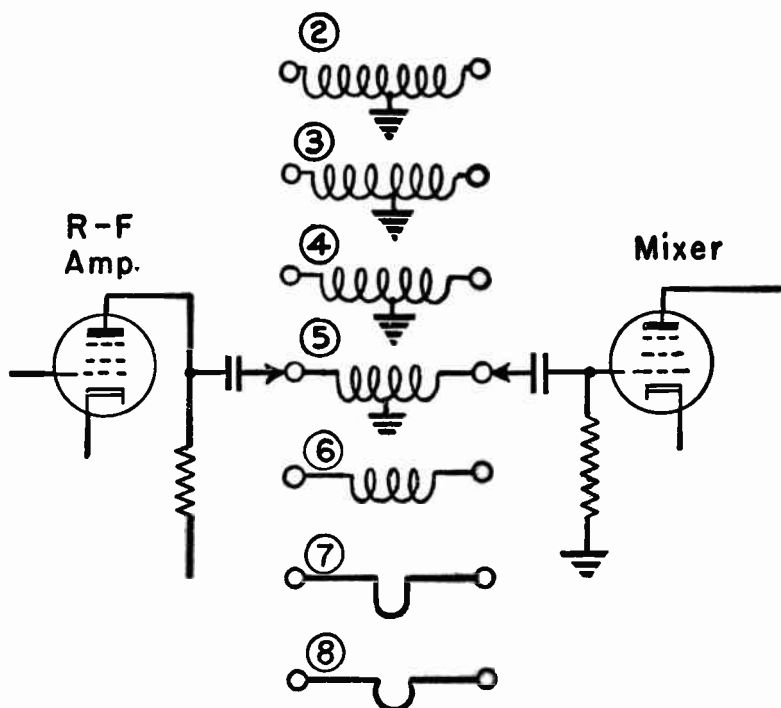

Fig. 3-2.—There may be separate tuned circuits for each channel.

set of tuned circuits or separate sections of a single tuned circuit. These separate circuits or sections are switched into the tube circuits according to the particular channel on which reception is desired.

Fig. 3-2 shows one method of providing separate tuned circuits for each channel. Only a few channels are represented, but the method may be extended for any number. This diagram shows the coupling between r-f amplifier and mixer, but the same switching method would be used also for tuned antenna couplings and for the oscillator circuit in any given receiver. Any of the tuned circuits may be connected between the two switch contacts indicated by arrowheads, one from the r-f amplifier plate and the other to the mixer grid.

You will note that in this and many similar diagrams there are

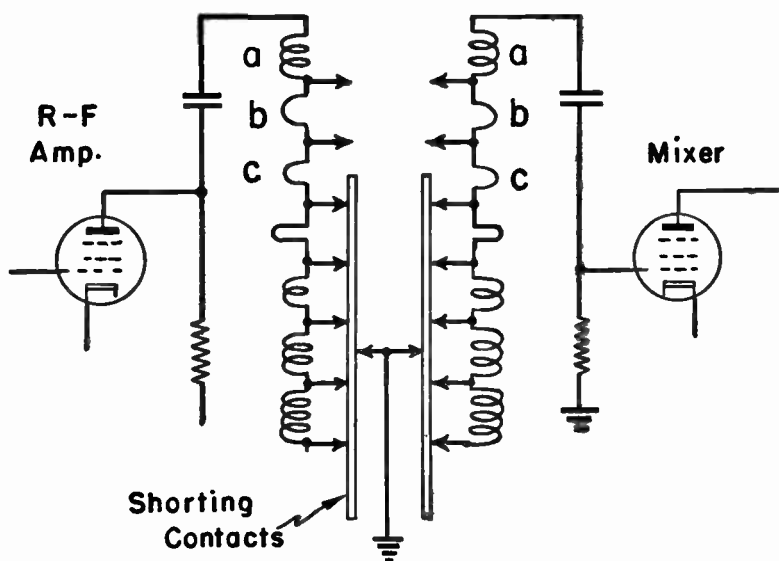

Fig. 3-3.—More or less of this tuned circuit is shorted to vary the resonant frequency.

shown tuning inductances but no tuning capacitors. Tuning capacitance is provided by the input and output capacitances of the tubes, by distributed capacitance in the inductor coils, and by stray capacitances in the wiring and other parts. All of these

capacitances together usually provide a total of 20 to 30 mmfd, which is ample for tuning at carrier and intermediate frequencies. The inductance of the coil is made of a value which, with the tube and circuit capacitances, is resonant at the frequency to be received or amplified. By using no additional tuning capacitance we may have maximum inductance for any given frequency, and this means a high-Q circuit.

Fig. 3-3 illustrates one method of employing more or less of the inductance and distributed capacitance in single tuned or tunable circuits. Operation of the channel selector moves the two shorting contacts along the arrowheads which represent contact points along the inductance elements. With the shorting contacts in the position shown, tuning inductance and distributed capacitance is provided by inductor sections *a*, *b*, and *c*. Moving the shorting contacts upward would short to ground more of the inductor sections, reduce the effective inductance, and raise the tuned frequency. Movement of the shorting contacts downward leaves more inductor sections ungrounded, and increases the inductance to lower the tuned frequency.

With construction such as shown by Fig. 3-3, the inductor elements usually are stationary and the shorting contacts are on a

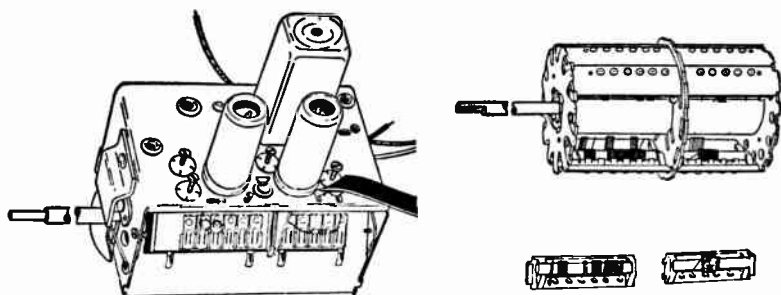

Fig. 3-4.—The parts of one style of turret tuner. (Stewart-Warner)

rotary switch turned to different positions by the channel selector control. The inductor elements are mounted very close to the switch wafers, or may be mounted directly on the wafers.

The same switching method may be used with circuits such as shown by Fig. 3-2. That is, the inductor or coil elements may be stationary, mounted on or close to a rotary switch, and the

contacts represented by the arrowheads may be on the switch rotor.

Separate tuned circuits of the general style shown by Fig. 3-2 may be switched also by means of a *turret tuner*. Then the inductor elements for the several channels are mounted on a turret or drum which is rotated by the channel selector control. The tube circuit contacts represented by arrowheads remain stationary while rotation of the turret or drum brings successive inductor terminals against the stationary contacts. Fig. 3-4 shows construction details of a typical turret tuner.

There are numerous mechanical and electrical variations of the channel switching methods so far described. The types illustrated are, however, sufficient to show the structural principles so far as they are important in service work.

Continuous Tuning.—An entirely different method of channel selection provides inductance-capacitance combinations which may be continuously tuned through either the entire range of television carrier frequencies or else tuned with one set of elements through the low band (channels 1 to 6) and with another set through the high band (channels 7 to 13).

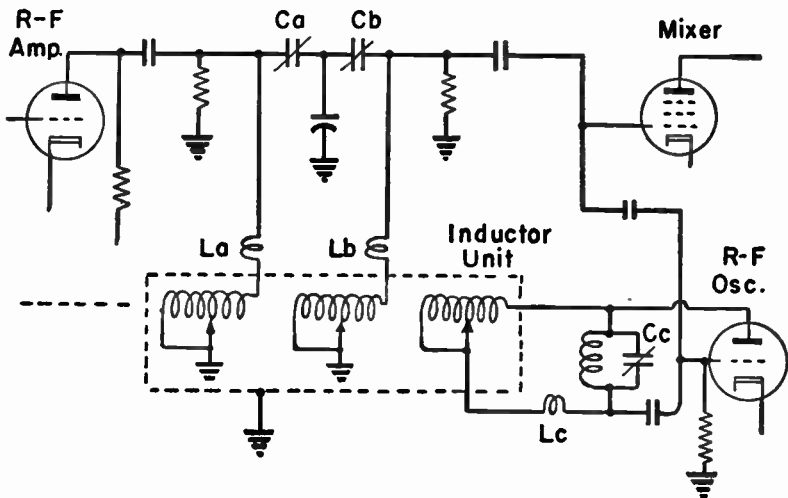

Fig. 3-5.—How a continuous tuner may be used between r-f amplifier and mixer tubes.

Fig. 3-5 shows elementary circuit connections for a tuner which allows uninterrupted coverage through the entire range of television carrier frequencies. Inside the inductor unit are three coils which are rotated by the tuner shaft and thereby caused to travel endwise. Resting against the turns of each coil is a stationary contact which shorts out whatever portion of the coil remains between one end and this contact point. Thus the effective inductance of each coil is varied. One of the tuned coils is in the plate circuit of the r-f amplifier, a second is in the control grid circuit of the mixer (or both may be considered as in the plate circuit) and the third is in the oscillator tank circuit.

The three adjustable capacitors, *Ca*, *Cb*, and *Cc*, and the three small coils, *La*, *Lb*, and *Lc*, are used for alignment adjustments. All the channel tuning is done by the rotating coils to vary their effective inductances. This unit tunes through the f-m broadcast band and all other radio bands lying between television channels 6 and 7.

There is another type of continuous tuner which does not cover the range of frequencies between television channels 6 and 7. Instead there is provided one set of tunable inductors covering channels 1 through 6, and a second set covering channels 7 through 13. Two-way switches automatically cut in whichever set of tunable inductors is suited to the desired channel, the switch-over being made by the tuning mechanism as the operator moves the channel selector between channels 6 and 7.

Most continuous tuners of the two-band type provide variation of tuning inductance by moving the core slugs one way and the other inside the coils as the channel selector control is rotated. Movement of the slugs may be brought about by cams on the tuner shaft or else by means of a screw with coarse threads. Fig. 3-6 shows the construction of one tuner of this general type. The screws at the right-hand end of the unit adjust the oscillator trimmer capacitor for each channel.

R-f Oscillator.—The oscillator which is in the tuner section of the receiver is spoken of as the r-f oscillator to distinguish it from the sweep oscillators. Another name is "local oscillator." The r-f oscillator in television receivers always tunes to frequency which is higher rather than lower than the carrier frequency. The difference between the carrier and oscillator frequencies is, of

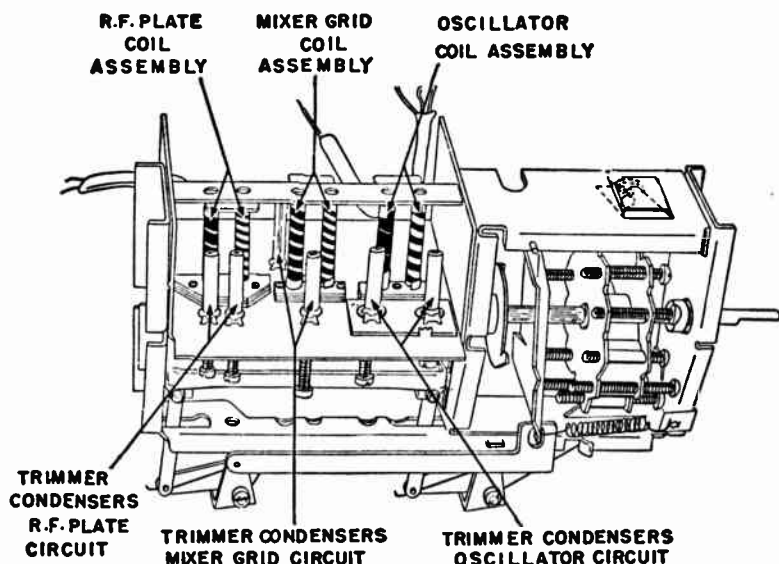

Fig. 3-6.—Construction of one style of two-band continuous tuner.
(Stewart-Worner)

course, whatever intermediate frequency is employed in the receiver.

Although antenna coupling circuits and the couplers between r-f amplifier and mixer must have a very wide frequency response, the r-f oscillator is sharply tuned to its frequency. Then the oscillator output frequency beats with the modulated carrier frequency to produce similarly modulated intermediate frequencies.

The single frequency produced by the r-f oscillator for any given channel beats with the amplitude-modulated video carrier to produce video intermediate frequencies fed to the video i-f amplifier. The same oscillator frequency beats with the frequency-modulated sound carrier to produce sound intermediate frequencies which pass through all or part of the video i-f amplifier to the sound amplifier, or, in some designs, directly from the mixer output to the sound i-f amplifier. The resulting video intermediate frequency is amplitude modulated, while the resulting sound intermediate frequency is frequency modulated.

Since we are not designing television tuners, but only servicing them, we are not particularly concerned with the theories and

characteristics of the types of oscillator circuits in particular receivers. Most of them are either modified Colpitts oscillators or modified Hartley oscillators. The "modification" consists principally in omitting most of the tuning capacitances used at lower frequencies, because tube and distributed capacitances are as effective for tuning in oscillator circuits as in the antenna and r-f amplifier circuits.

The great majority of oscillator tubes are triodes, either single or twin types. This is because the internal grid-plate capacitance in a triode is much greater than in a pentode, and helps provide feedback for maintaining energetic oscillation at high frequencies. In common with the r-f amplifiers and mixers, the oscillators in tuners of recent design are miniature tubes.

Oscillator frequency most often is fed to the control grid of the mixer through a small capacitor connected between the oscillator tank circuit and the mixer grid. The coupling capacitance seldom is more than 5 mmfd and may be even less than 1 mmfd. Another method is to mount the oscillator tuning coil and the coil in the mixer grid circuit on the same form so that there is inductive coupling between the circuits. This is fairly common with turret tuners, and may be found with other styles. There are several other methods of coupling the oscillator and mixer circuits, as through a link inductively coupled at one end to the oscillator and at the other end to the mixer, or by having a cathode-to-ground resistor which is common to both tubes. This latter method is found with some designs which use a twin tube with a single cathode for oscillator and mixer.

Oscillator Frequency Drift.—It is a well known fact that when any ordinary oscillator circuit has been tuned to a certain frequency there is likely to be some change or drift of frequency in one direction or the other, either steadily until reaching some new frequency or else intermittently one way and the other. If fluctuations of line voltage cause any decided changes in B+ voltage to the oscillator, the frequency may vary with the line voltage.

Even with a reasonably constant line voltage it is possible for changes of temperatures during the warmup period to so alter the dimensions or positions of circuit parts as to affect the oscillator frequency. Then the frequency will become steady only after the parts have reached normal working temperatures. Such

TELEVISION TUNERS

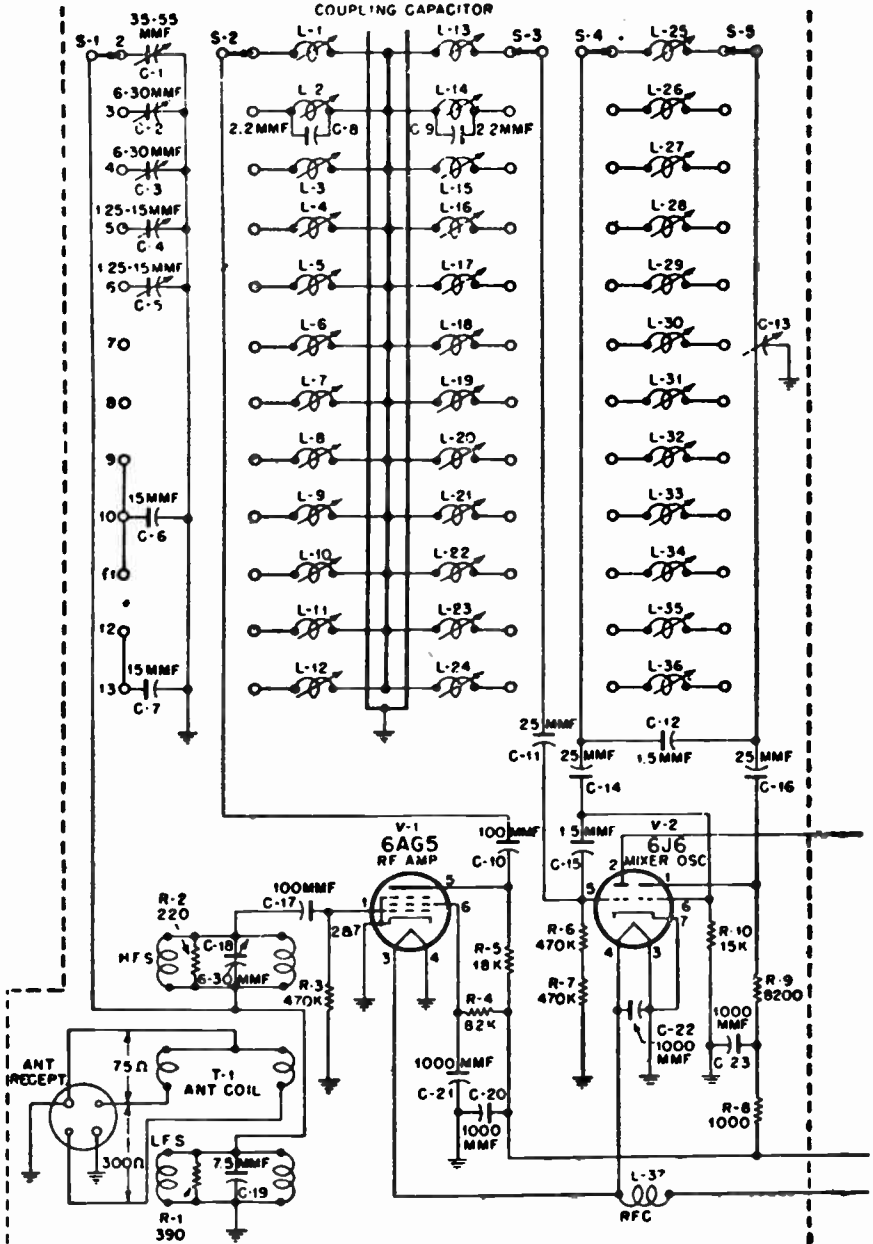

Fig. 3-7.—R-4 input with tuning in two bands and connections for either of two types of transmission line. (Motorola)

effects are counteracted to greater or less extent by using, in the tuned circuit of the oscillator, capacitors having a negative temperature coefficient.

In some types of receivers the adjustment of r-f oscillator frequency is quite critical. This is because the deviation in the frequency-modulated sound signal is plus or minus only 25 kilocycles and the response of the sound i-f amplifier is only 100 to 250 kilocycles at most. If oscillator frequency drifts very far the sound signal will be lost. In many receivers of this general type there is a small vernier capacitor connected across the oscillator tuned circuit. The adjustment of this capacitor, usually called the fine tuning control, is varied by the operator to obtain most satisfactory reception on whatever channel is tuned in.

When there is an operator's control for oscillator frequency, whether called a fine tuning control or by some other name, it requires adjustment only during and at the end of the warmup period, until frequency drift has ceased. As would be expected, these vernier controls are capable of varying the oscillator frequency through an increasing range as the set is tuned to higher and higher carrier frequencies.

Tuner Designs.—Certain features of tuners and antenna connections may best be explained by means of typical circuit diagrams. While the examples to be shown illustrate exact methods of connection and operation for particular makes and models of receivers, they illustrate also many general principles found in other types.

In the matter of antenna or transmission line connection there may be provision for only a 300-ohm balanced line, for only a 72-ohm unbalanced line, or for a choice of either type. In Fig. 3-7 the antenna receptacle is at the lower left. A 300-ohm balanced line would be connected to the two small pins, thus placing the line across both parts of winding *T-1* whose center tap is grounded at one of the receptacle terminals. A 72-ohm line would be connected to the two upper terminals of the receptacle, with the shield of the line cable to ground, and the central conductor of the cable to one half of winding *T-1*. Thus we have impedance matching for either type of line.

Winding *T-1* forms the primary of an antenna transformer. There are two secondaries, one above and the other below the

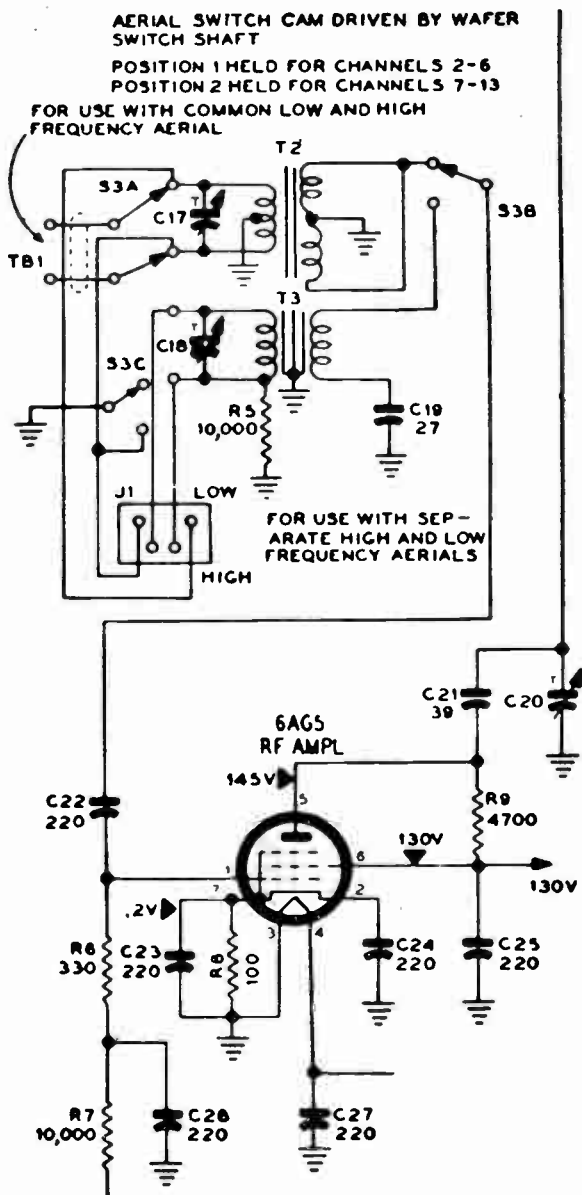

Fig. 3-8.—Connections allowing either one or two antennas for the low and high bands. (Philco)

primary. The upper secondary is tuned for acceptance of all frequencies in channels 7 to 13. The lower one is tuned to accept all frequencies in channels 1 to 6. Connected to a point between the two secondaries are additional alignment adjustments for some channels. These are the adjustable capacitors shown along the upper left-hand side of the diagram.

In some receivers there is no variable or adjustable tuning of any kind between the antenna terminals and the input to the r-f amplifier. In this case the two sides of a balanced 300-ohm line usually are connected to control grid and cathode of the r-f amplifier, with various arrangements of coils which are center tapped to ground, and of added pairs of capacitors and resistors with connections from between them to ground.

In Fig. 3-8 there is one complete antenna transformer for the high-band channels and a second complete transformer for the low-band channels. A switch operating with the channel selector cuts in either one or the other transformer. There is provision here for using a single antenna for both bands and also for using separate antennas and transmission lines for each of the two bands.

Channel Switching.—Fig. 3-9 shows details of tuning inductor connections to the wafers of a rotary switch used for channel selection. Input from the plate of the r-f amplifier is at the lower left. The rotor on the rear of the wafer at the extreme left makes connection from the plate circuit to the outer end of whichever of the coils $L1$ to $L11$ is to be active for the selected channel. At the same time the rotor on the front of this wafer shorts together the outer ends of the other coils.

Rotors on the front and rear of the wafer on the right make similar active and shorting connections for coupled coils $L12$ to $L22$, which are in the grid circuit of the mixer. There are no alignment adjustments of this coupling between r-f amplifier and mixer. Adjustable capacitor $C3$, from mixer grid to ground, is used during alignment of the high-band channels.

Oscillator tuning coils $TC1$ to $TC12$ are shown by Fig. 3-10, between the upper and lower switch wafers used for the oscillator circuit. The rear rotor of the top wafer shorts together the upper ends of all coils which are not to be active for the selected channel. At the same time the rear rotor of the bottom wafer shorts to-

gether the lower ends of all inactive coils. The front rotors of each wafer makes connections between plate and grid of the oscillator and the oscillator coil which is to be active for the selected channel. Note that coil *TC1* always remains active.

There are individual alignment adjustments for each of the twelve oscillator coils. It is rather common practice to provide separate alignment adjustments for the oscillator inductors in each channel, even though there are adjustments for only some

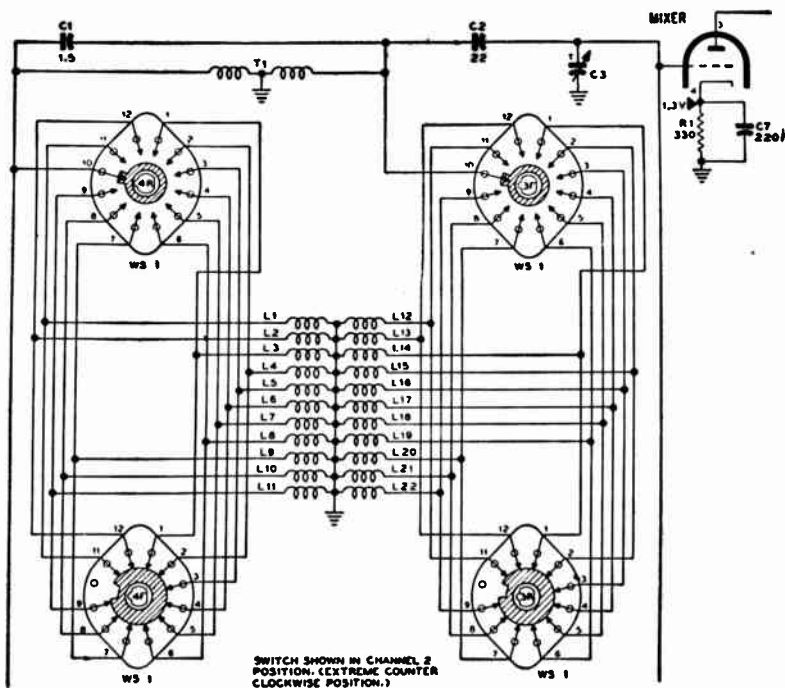

Fig. 3-9.—Channel tuning between the r-f amplifier and mixer. (Philco)

channels or for none at all in the couplings from antenna to r-f amplifier and from r-f amplifier to mixer.

In Fig. 3-11 we have the complete diagram for a tuner in which the coupling between r-f amplifier and mixer consists of inductors in which various portions are shorted together and to ground for varying the resonant frequency. The plate of the r-f amplifier is coupled to the mixer grid through capacitor *C130* for all channels,

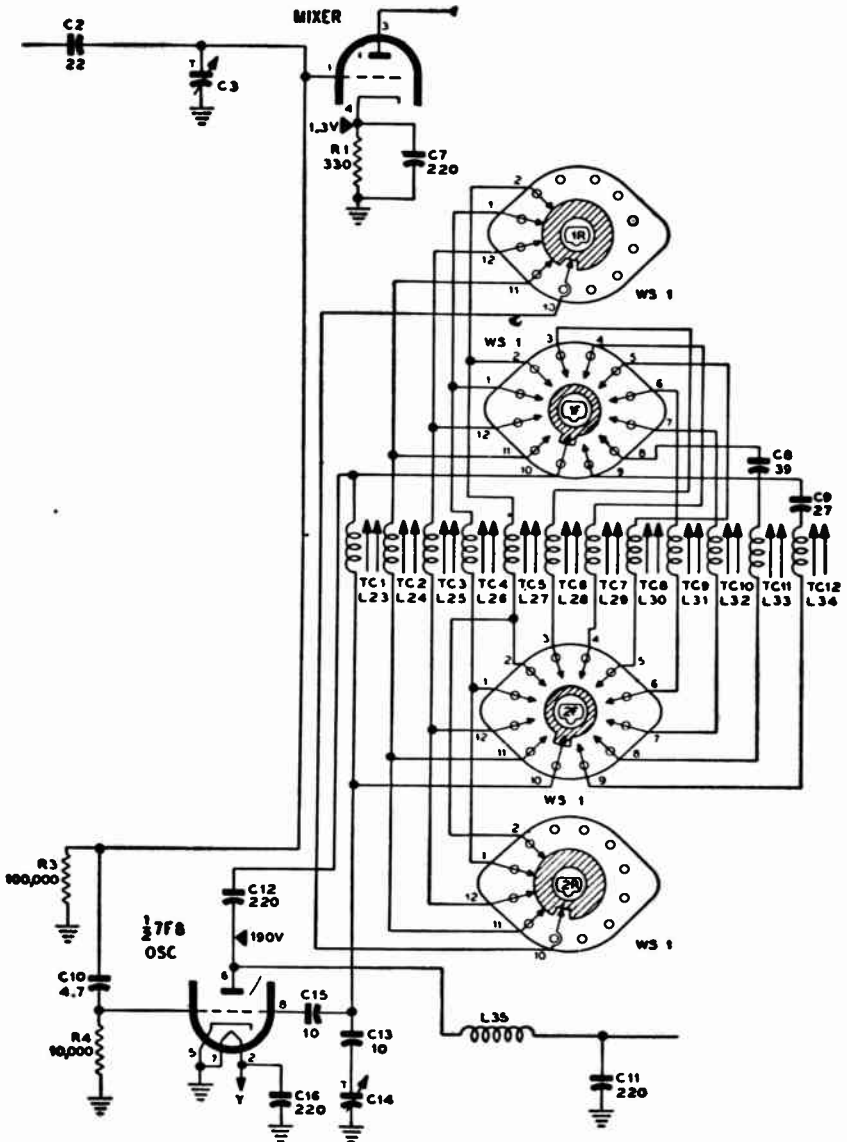

Fig. 3-10.—Individual alignment adjustments for twelve channels on the r-f oscillator. (Philco)

and additionally on the low-band channels through capacitors *C124* and *C125*. The amplifier plate inductors and mixer grid inductors are separated electrically by means of a metal shield plate.

The plate inductors, *L38* to *L49*, and the mixer grid inductors, *L51* to *L62*, are similar. Each consists of twelve small coils wired in series. As the channel selector switch is rotated toward the higher frequency channels, the inductance is progressively short circuited to leave only sufficient inductance to resonate the circuits at the frequency of the desired channel.

In the tuner circuit for the oscillator, shown at the bottom of the diagram, there is a separate coil for each channel. Individual

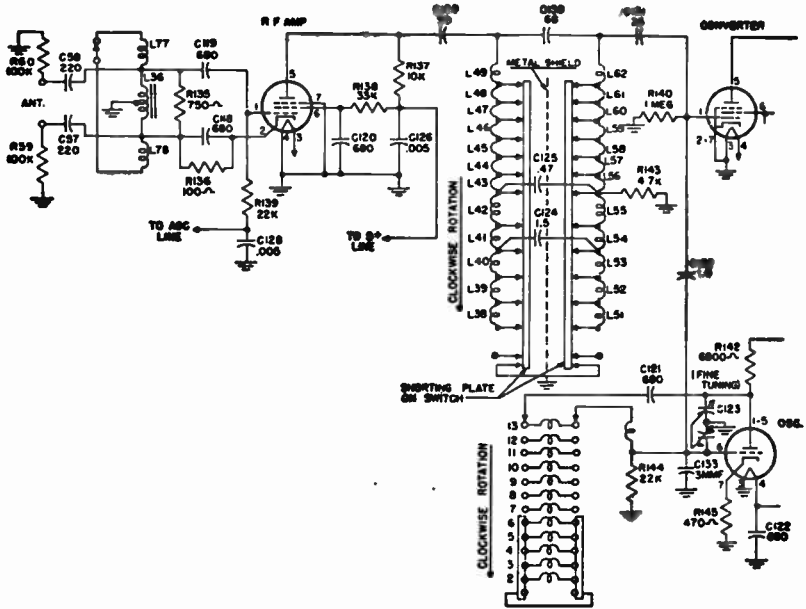

Fig. 3-11.—Tuner in which portions of the inductances are shorted out for successive channels. (Westinghouse)

coils are connected to the plate and grid of the oscillator by movement of switch rotors, which are indicated by arrowheads on the diagram.

Some receivers can be operated on eight channels, but not on all channels. The eight channels are selected to suit the locality

in which the receiver is to be used. This provides complete coverage because, in any one locality, transmitters do not operate on channels whose upper and lower frequency limits are immediately adjacent. For example, in Chicago and New York there may be transmissions on channels 2, 4, 5, 7, 9, 11 and 13, but not on other channels.

Selection of channels is made in some receivers by installing sets of tuning inductors suited to the available channels. In other receivers the selection is made by alignment of inductors permanently installed.

Selection by alignment adjustment is illustrated by Fig. 3-12. At the upper right are eight inductors for oscillator tuning. Inductors *L-17* and *L-18* always are aligned respectively for channels 1 and 2. But the range of adjustment for *L-19* is great enough

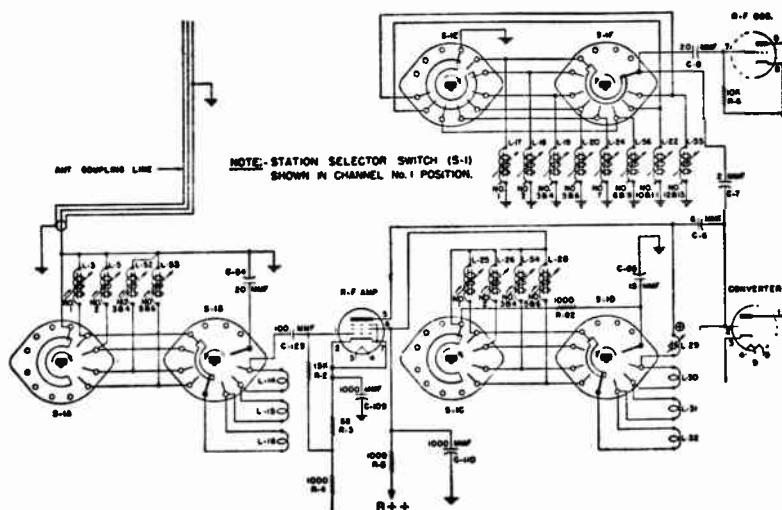

Fig. 3-12.—A tuner which may be aligned for reception in any eight channels. (Motorola)

so that it may be set either for channel 3 or else channel 4. Inductor *L-20* may be aligned either for channel 5 or channel 6. Inductor *L-24* always is aligned for channel 7, but each of the remaining inductors may be aligned for either of two channels.

Tuning coils for the antenna coupling are at the lower left, and those for coupling between r-f amplifier and mixer are at the lower

right. In each of these sets one coil is aligned for channel 1 and another for channel 2. The other two coils may be aligned either for channel 3 or 4, and for channel 5 or 6. For the high-band channels the response is sufficiently broad as to require no inductors which are adjustable in the field to one channel or another. Consequently, on channels 7 to 13, inductors *L-16*, *L-15*, and *L-14* are used and progressively shorted out. This same general method of switching and channel selection is used for the coupling between r-f amplifier and mixer.

Turret Tuners.—Fig. 3-13 shows connections for a typical turret tuner used for channel selection. On the turret which is rotated by the channel selector control are two groups of coils for each channel. The group shown within broken lines between antenna terminals and the grid-cathode circuit of the r-f amplifier forms the antenna coupling transformer. The primary and secondary windings shown by the diagram represent those for any one channel. Rotation of the turret brings other pairs of coils into this position.

The second set of windings on the turret is shown within broken lines between the r-f amplifier and the single-envelope oscillator

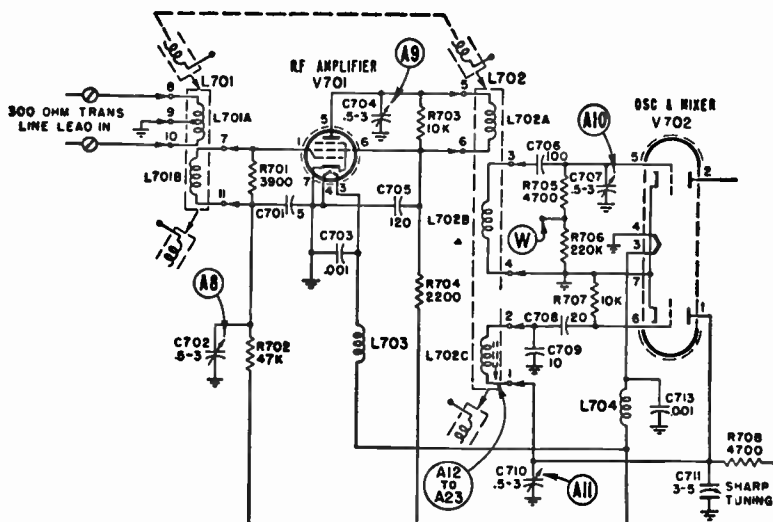

Fig. 3-13.—How separate sets of inductors are switched into the tube circuits for each channel. (Admiral)

and mixer. Here we have at the top a coil which is connected into the plate circuit of the r-f amplifier. Next below, and inductively coupled, is a coil in the grid circuit of the mixer. At the bottom is the oscillator coil inductively coupled to the mixer coil. Again the three coils in the diagram represent those for any one channel, with others of different frequency characteristics brought into this position by rotation of the turret.

There are no alignment adjustments for separate channels on the antenna couplings or on the couplings between r-f amplifier and mixer. There are, however, adjustable capacitors *A8*, *A9*, and *A10* which affect tuning in all channels. These three capacitors are adjusted to secure a tuner response curve covering the required band width while reasonably symmetrical on both sides with a suitable flat top, and, with other requirements satisfied, having maximum amplitude or gain. The oscillator coil for each channel is individually aligned by a tuning slug, as indicated at *A12* to *A23*. There is also an adjustable capacitor *A11* which affects the oscillator tuning on all channels. This is a service adjustment, and is in addition to the sharp tuning or fine tuning capacitor *C711* which is an adjustment used by the operator.

Two-band Continuous Tuners.—Circuit connections for a two-band continuous tuner are shown in Fig. 3-14. Input from the antenna is from a 300-ohm balanced transmission line connected across impedance matching coil *L1* to the control grid and cathode of the r-f amplifier, at the top of the diagram. Into the plate circuit of the r-f amplifier a two-way switch connects either one of the coils *T1* and *T2*, one for the low-band channels and the other for the high-band channels. Whichever of these coils is being used is coupled through capacitors *C117*, *C118*, and *C6* to coils *T3* or *T4*. The selection is made through a second two-way switch shown just above the coils. One coil is used on the low-band channels, the other on the high band. These coils are in the grid circuit of the mixer. The mixer is one half of a 6J6 twin triode.

The other half of the 6J6 is the r-f oscillator. Oscillator tuning coils for the low and high bands are marked *T5* and *T6*. These are selected by a third two-way switch. All the two-way switches are operated as the channel selector is moved between channels 6 and 7.

Inside each of the tuned coils are iron cores moved by the

TELEVISION TUNERS

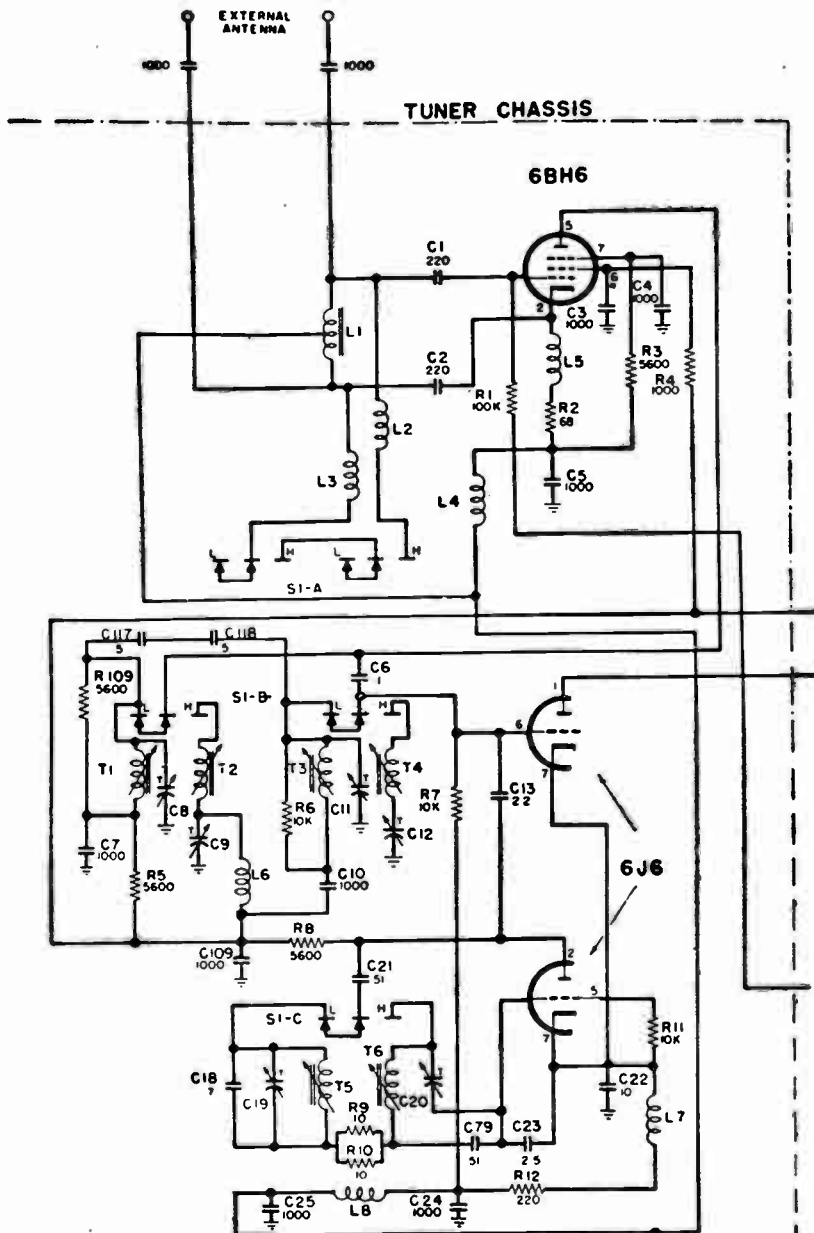

Fig. 3-14.—Continuous tuning in each of the two television frequency bands. (Belmont)

70 APPLIED PRACTICAL RADIO-TELEVISION

channel tuner control for resonance at the frequency of the desired channel. Connected across each tuning coil is a trimmer capacitor used during alignment. On the r-f amplifier plate coils are trimmer *C8* for the low band and *C9* for the high band. On the mixer grid coils are *C11* for the low band and *C12* for the high band. These four trimmers are used to obtain a tuner response curve of sufficient band pass, with symmetrical peaks, and maximum gain without upsetting other qualities. Trimmer capacitors for peaking the r-f oscillator are *C19* for the low band and *C20* for the high band.

Chapter 4

TELEVISION SOUND

It is necessary that we consider television sound systems before proceeding to video amplifiers and other sections. The reason is that the type of sound amplifier affects not alone the method of aligning the sound circuits, but also the design of the video i-f amplifier and following video amplifier, and determines the alignment procedures which may be employed in these sections of the receiver.

In order to have definite intermediate frequencies to illustrate the behavior of sound systems we shall consider what happens to certain carrier frequencies which come into the tuner. In channel 4, for example, the video carrier is at 67.25 mc and the sound carrier at 71.75 mc. We may assume that when our r-f oscillator is tuned for this channel its frequency is 93.35 mc. The difference between the oscillator and video carrier frequencies (93.35 minus 67.25) is 26.1 mc. This is our video intermediate frequency. The difference between the oscillator and sound carrier frequencies (93.35 minus 71.75) is 21.6 mc. This is our sound intermediate frequency.

Here, in passing, we may make note of the relations between carrier and intermediate frequencies. The sound carrier frequency in nearly all receivers is higher than the video carrier frequency in the same channel. But in the difference frequencies produced by the r-f oscillator the sound intermediate frequency is lower than the video intermediate frequency. This always is true on all channels and for any carrier and intermediate frequencies which might be considered.

The sound system which has been longest in use may be represented as in Fig. 4-1. Continuing with our assumed intermediate frequencies, both of them pass from the mixer to the video and sound intermediate amplifying stage of this diagram. Both are amplified and both appear in the output of this stage. Then the sound intermediate frequency of 21.6 mc is taken off and applied to the first stage of the sound intermediate amplifier.

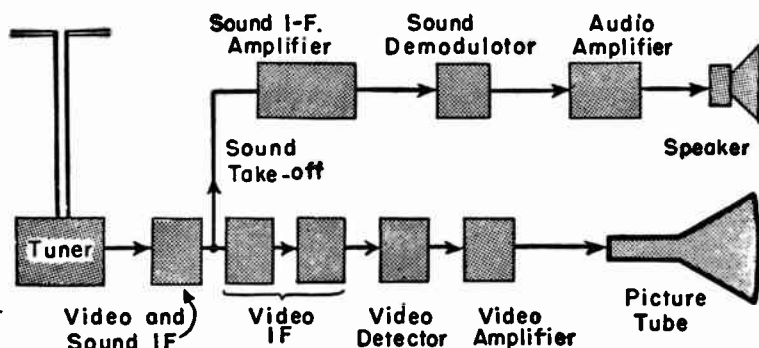

Fig. 4-1.—A sound system in which the *i-f* amplifier and demodulator operate at the sound intermediate frequency.

Without affecting the general principles of this system the sound intermediate frequency might be taken off immediately after the mixer. Then there would be no amplifying stages handling both sound and video. Or the sound might be taken off after two or even three intermediate amplifying stages. Then there would be more stages handling both sound and video. The really important fact, regardless of point of takeoff, is that the frequency fed to the sound intermediate amplifier is the sound intermediate frequency of 21.6 mc.

This sound intermediate frequency is frequency-modulated with the audio signals. All of the sound *i-f* stages operate at the sound intermediate frequency, and it passes through the demodulator where the high frequencies are discarded and the audio signal passed on to the audio amplifier and loud speaker. The demodulator may be a discriminator or else a ratio detector in its basic circuit.

A more recent development in the field of sound reproduction is called the *intercarrier sound* system. Signal travel in this system is shown by Fig. 4-2. The video and sound carriers beat together in the mixer to produce the same video and sound intermediate frequencies as with any other method. But instead of the sound intermediate being taken off at some point well ahead of the video detector, both the sound and the video intermediate frequencies continue together through all the *i-f* stages, and both are applied to the video detector.

The two intermediate frequencies beat together in the video detector. The detector acts as a mixer for these frequencies. In

its output is a new frequency at the difference between the incoming intermediates. The difference between any video intermediate frequency and the accompanying sound intermediate frequency is 4.5 mc. This is because the difference between the video carrier and sound carrier frequencies in any one channel always is 4.5 mc. Consequently, the new beat frequency from the detector always must be 4.5 mc.

Since the 4.5 mc frequency results primarily from the frequency difference between the two carriers it is called an inter-

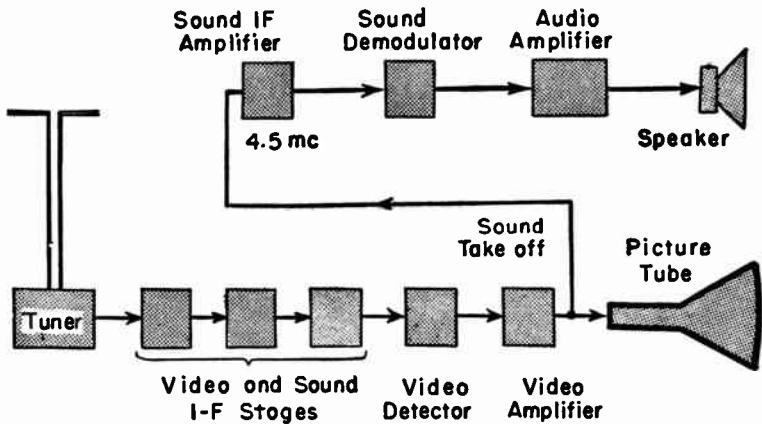

Fig. 4-2.—The takeoff point for an intercarrier sound system follows the video detector.

carrier beat frequency. The 4.5-mc intercarrier beat is frequency-modulated with the sound signals. That is, superimposed on the 4.5-mc frequency is the 25 kilocycles plus or minus deviation which is the f-m sound signal accompanying all television signals.

The 4.5-mc intercarrier beat or intercarrier sound goes through the video amplifier, where it is strengthened along with the video signal. The intercarrier sound frequency, with its modulation, is taken off at the output of the video amplifier and fed to the sound i-f amplifier. From the sound i-f amplifier the signal goes to the sound demodulator where the frequency deviations produce amplitude modulation which is the audio signal, just as in any other f-m sound system.

Now we may commence looking for reasons why the kind of sound system affects service operations. The frequency response of the tuner does not vary, it may be the same with either sound

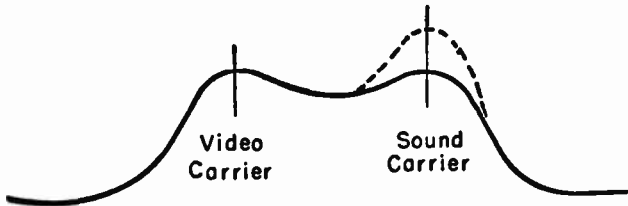

Fig. 4-3.—Frequency response of an r-f stage or a tuner.

system. A typical tuner response curve is shown by Fig. 4-3. Usually there are two peaks which are more or less pronounced. The video carrier frequency is at or near the peak of lower frequency, while the sound carrier frequency is at or near the peak of higher frequency. This latter peak sometimes is higher than the video-carrier peak, giving more amplitude on sound than on the video carrier. This higher sound peak may be found in receivers which do not use intercarrier sound.

When the sound system operates at the sound intermediate frequency, not at the intercarrier beat, response curves for the i-f amplifiers following the mixer are about as shown in Fig. 4-4. In stages before the sound takeoff, which carry both video intermediate and sound intermediate frequencies, the response of all such stages combined will be somewhat as shown at the left. There will be enough gain at the sound intermediate to carry the sound signals through these stages in fair strength.

The video intermediate frequency always is about half way down on the high-frequency side of the response. This provides a uniform output for all the frequencies which are transmitted in double strength with vestigial sideband transmission. We shall consider this feature at length in connection with video i-f amplifiers, but just now we are chiefly concerned with sound frequencies.

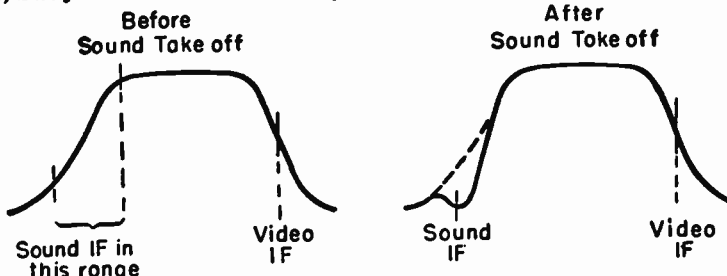

Fig. 4-4.—Video i-f responses where the sound system operates at the sound intermediate frequency.

In all video i-f stages following the point of sound takeoff the response at the sound intermediate frequency is made as low as possible, as shown at the right in Fig. 4-4. This is because it is highly undesirable to have sound signals reach the picture tube. The reduction of sound i-f response is accomplished by careful tuning of these video i-f stages and by the use of wave traps which attenuate or absorb the sound intermediate frequency.

When the receiver uses an intercarrier sound system the overall response of the entire video-sound i-f amplifier, from mixer to video detector, must be about as shown in Fig. 4-5. Now the position of the sound intermediate frequency on the response curve is critical. The gain at this point must be from 90% to 97½% "down" from the peak gain. In many receivers this gain must be down at least 95%. This is a voltage attenuation of between 26 and about 32 decibels.

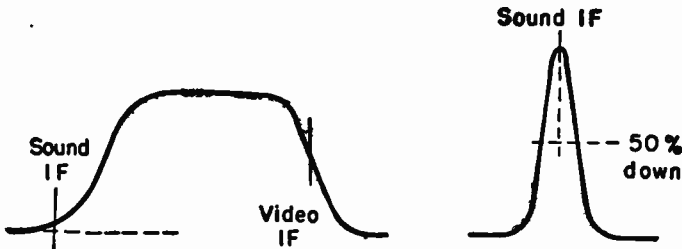

Fig. 4-5.—Video i-f response when intercarrier sound is used.

Fig. 4-6.—Response curve of a sound i-f amplifier.

If the sound intermediate frequency is brought too high on the response curve the gain will be so great that sound signals will be forced on through the video amplifier and into the picture tube grid-cathode circuit. If the sound intermediate is too low on the response curve the gain will be too small for good sound reproduction from the loud speaker.

Now look at Fig. 4-6. This is a fairly typical response curve for the i-f amplifier in a sound system, the amplifier which follows the sound takeoff and precedes the sound demodulator. This amplifier is peaked at the sound intermediate frequency. The response is about 50% or 6 db down at frequencies only 0.15 to 0.20 mc either side of the peak. We have a useful response over a range only about 0.30 mc wide.

In every receiver the actual intermediate frequencies are de-

terminated by the frequency of the r-f oscillator, since this frequency beats with the carrier frequencies to produce both intermediates. If the oscillator is tuned 1.0 mc too high it will raise both the video and the sound intermediate frequencies by 1.0 mc, and if the oscillator is 1.0 mc too low it will drop both intermediates by 1.0 mc. The amplifiers still will be tuned to the original intermediate frequencies, but the actual frequencies fed to the amplifiers will be too high or too low.

If the sound system is designed to operate at the normal sound intermediate frequency, and the oscillator frequency varies by as much as 1.0 mc, the actual frequency reaching the sound i-f amplifier will be completely outside the effective range of that amplifier, as is evident from Fig. 4-6. There will be no reproduction of sound, although there still will be a picture of some sort. Actually, the frequency of the r-f oscillator must be correct within less than 0.10 to 0.15 mc in order to have reproduction of sound signals.

Consider now what happens when there is an intercarrier sound system. No matter how far from correct the r-f oscillator frequency may be, it affects both the video and the sound intermediate frequencies equally. They always must remain separated by 4.5 mc, for that is the separation of the original carriers. Then there always will be a 4.5 mc beat frequency produced at the video detector, and this will be fed to the sound i-f amplifier.

Do not conclude that tuning or alignment of the r-f oscillator is not critical when we have intercarrier sound. Misalignment shifts the sound and video intermediate frequencies on the response curves of amplifiers between mixer and detector and causes much trouble. One of the really important conclusions is this: With a sound system operating at the regular sound intermediate frequency it is easy to align the r-f oscillator by connecting an electronic voltmeter or an oscilloscope to the output of the sound demodulator. The output will be as sharp as indicated in Fig. 4-6 when oscillator frequency is exactly correct, and will fall off rapidly with very slight misalignment of the oscillator. With intercarrier sound we cannot align the r-f oscillator by working through the sound system. No matter how far out of alignment the oscillator may be, we still have a 4.5 mc beat to which the sound i-f amplifier is tuned.

video amplifier plate to the picture tube grid-cathode circuit. The secondary is connected between control grid and cathode of the sound i-f amplifier. Ordinarily there is only one such amplifier in intercarrier sound systems.

A double tuned takeoff transformer of the kind shown in Fig. 4-8 may be in the screen circuit of the video amplifier. Then the transformer primary is between the screen grid of the tube and the B+ supply. The secondary winding is connected to the control grid-cathode circuit of the sound i-f amplifier.

With the arrangement of Fig. 4-9 the takeoff lead is connected to the plate of the mixer, any of the i-f amplifiers, or the video amplifier. At C_c is a coupling and blocking capacitor, which sometimes is adjustable. The impedance coupler L_g , on the control grid of the sound i-f amplifier, is slug tuned to the sound intermediate frequency or to the intercarrier beat frequency as required. There may or may not be a capacitor across L_g .

Still another takeoff coupling of the tuned type is shown by Fig. 4-10. Inductor L_g is slug tuned to whatever sound intermediate frequency may be used. Voltages at this frequency then are secured from untuned inductor L_t which is inductively coupled to the coupling transformer between the i-f amplifier which carries both sound and video, and the following video i-f amplifier.

Untuned sound takeoffs usually are connected to the plate of the mixer or any i-f amplifier through a small capacitor, as in

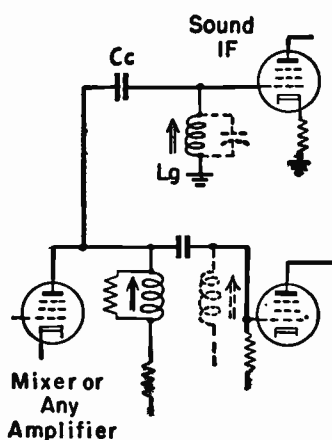

Fig. 4-9.—A capacitor-coupled sound takeoff.

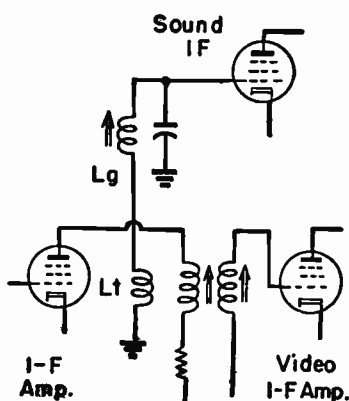

Fig. 4-10.—An inductively coupled sound takeoff.

Fig. 4-9, but there is no tuned impedance or other type of tuned coupling in the circuit. Then the sound intermediate frequency which affects the sound i-f amplifier is determined by tuning in the couplings which follow this amplifier, the couplings between it and the sound demodulator.

Sound Discriminator.—Except for its higher operating frequency, the sound discriminator used in a television sound system is no different from the discriminator used in an f-m sound re-

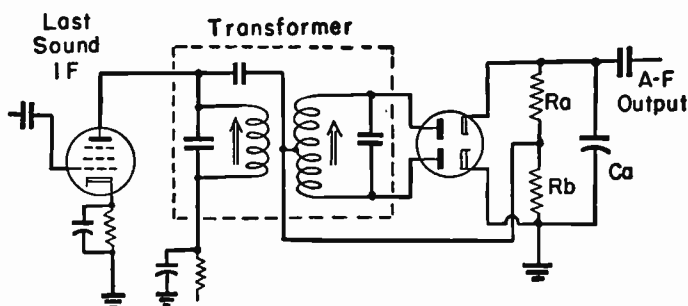

Fig. 4-11.—Typical circuit of Foster-Seeley discriminator for f-m sound.

ceiver, with which we are familiar. A typical discriminator circuit is shown by Fig. 4-11, where the transformer is within the broken lines. Alignment of television discriminators nearly always is by means of movable slugs rather than with trimmer capacitors. Audio output is taken from the ungrounded ends of load capacitor C_a and load resistors R_a and R_b . There are numerous modifications of the basic discriminator circuit, especially in couplings and points for grounding, but these modifications do not affect the operation nor the methods of alignment.

Ratio Detector.—A more recent development in the line of f-m or television sound demodulators is the ratio detector. A typical circuit for such a detector is shown by Fig. 4-12. Note that the transformer secondary is connected to one cathode (pin 5) and to one plate (pin 7) of the twin diode, whereas with the discriminator type of demodulator the secondary is connected to both plates of the twin diode.

The Admiral Corporation, who use ratio detectors in some models, gives the following explanation of the action, which is reproduced here by permission. The d-c blocking capacitor C_8 couples the audio output of the ratio detector to the volume con-

trol (not shown). This network serves as the output load for the ratio detector, and is connected between point *Z* and ground. Capacitor *C6* is the i-f bypass for this load.

The ratio detector transformer develops equal voltages at diode pins 5 and 7, with respect to point *Z*, when the sound i-f input signal is exactly 4.5 mc for intercarrier sound or exactly at the sound intermediate frequency for other sound systems. The conduction path for the lower diode, during one-half the sound i-f input cycle, is from cathode pin 5 to plate pin 2, through *R6* to ground, through the load circuit to point *Z*, through *R4*, through the transformer from terminal *a* to terminal *b* and back to the cathode. Since conduction is from ground to point *Z*, this conduction current will tend to cause point *Z* to become positive.

Tracing the conduction path for the upper diode, conduction is from cathode pin 1 to plate pin 7, through the transformer from terminal *c* to terminal *a*, through *R4*, through the load circuit from point *Z* to ground, through *R5* and back to the cathode. Since this conduction is from point *Z* to ground, the conduction current will tend to make point *Z* negative.

The voltages applied to the two diode sections are equal. Their conduction currents flow through the load, between point *Z* and ground, in opposite directions. Consequently, the conduction currents cancel and point *Z* will assume ground potential.

If the sound i-f signal swings to a higher frequency, above 4.5 mc or the sound intermediate, the sound i-f voltage at diode pin 5 will increase, while the voltage at pin 7 will decrease. This is due to change of voltage phase relations with change of frequency, just as in a discriminator transformer. Conduction current of the lower diode now will be greater than that of the upper section, and will cause point *Z* to swing positive. Conversely, if the sound i-f voltage swings lower in frequency, the sound i-f voltage at diode pin 7 will increase while the voltage at pin 5 will decrease. Point *Z* now will swing negative.

Successive increases and decreases in sound intermediate signal frequency cause point *Z* to swing alternately positive and negative. Frequency modulation of the sound i-f signal thus is converted into audio frequencies.

With the preceding description of f-m detection, our next concern is the method of obtaining limiter action, and a-m noise re-

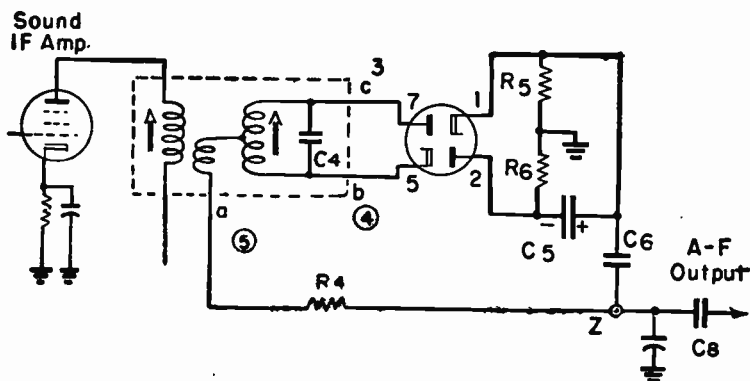

Fig. 4-12.—Typical circuit of a ratio detector for f-m sound.

jection, in a ratio detector. The sound i-f signal voltage appears across C_4 in the tuned secondary of the ratio detector transformer. A conduction current will flow during positive half-cycles from cathode pin 5 to plate pin 2 of the lower diode, thence through R_6 and R_5 , from cathode pin 1 to plate pin 7 of the upper diode, and back to the other side of capacitor C_4 . This conduction current represents the normal load on the transformer, and is determined by average sound i-f signal strength.

The voltage developed across R_5 and R_6 due to diode conduction current (as described in the preceding paragraph) is filtered by capacitor C_5 and maintained at a value proportional to average sound i-f signal strength. The voltage across C_5 , plus the voltages across the two diodes, is equal to the voltage across capacitor C_4 during the time that diode conduction is taking place.

If an amplitude noise pulse causes a momentary increase in the sound i-f signal voltage across C_4 , this added voltage must appear across the diodes. This is because the voltage across C_5 is unable to follow such rapid variations. The capacitance of C_5 here is 4 mfd. The time constant of R_5 , R_6 , and C_5 is 0.08 second. An increased conduction current flows and results in an increased load on the transformer. This increase in loading tends to reduce the sound i-f signal voltage to its average value.

Similarly, a momentary reduction in sound i-f signal voltage results in reduced voltages across the diodes, reduced conduction current, reduced loading, and tendency for the sound i-f signal voltage to come up to its average value. This amplitude limiting

action of a ratio detector may be summarized as follows: Variations of sound i-f signal amplitude are removed by connecting the large capacitance of $C5$ across the tuned secondary of the transformer through the diodes.

A change in average signal amplitude, such as might take place when switching from one station to another, will cause the charge on $C5$ to assume a value proportional to the new average signal amplitude. The signal across $C4$ now will be limited to a new average amplitude, and the audio output level from the ratio detector will change accordingly. The audio output of the ratio detector is greater for strong signal inputs than for weaker signal inputs. A-m noise rejection is, however, obtained at all levels because the ratio detector automatically adjusts itself to the average signal amplitude, and then rejects amplitude noise pulse variations. This concludes the extract from Admiral service literature.

There are a great many variations in circuit connections for ratio detectors, but all such detectors operate essentially as just described. The audio output always is connected more or less directly to the center tap on the transformer secondary. There always is a large capacitance connected between the two diodes on their output side. The primary and secondary windings of the transformer are tuned or aligned to the same frequency, which is the center frequency of the f-m input signal.

The ability of the ratio detector circuit to subdue amplitude-modulated noise pulses makes it unnecessary to use a limiter tube ahead of this detector. The discriminator does not in itself completely eliminate amplitude modulation, and the i-f amplifier ahead of it is operated as a limiter. Either type of demodulator might be used with intercarrier sound systems or with systems operating at the sound intermediate frequency. Actually, intercarrier sound systems nearly always are used with ratio detectors rather than discriminators. The ratio detector is found also with the other types of sound systems.

Chapter 5

VIDEO I-F AMPLIFIERS

Between the output of the mixer and the input to the video detector are a number of intermediate-frequency amplifying stages. All these stages carry and amplify the video intermediate frequency, hence all of them may be called video i-f amplifying stages. But, as we have noted before, any of these stages which precede the sound takeoff carry the sound intermediate frequency as well as the video intermediate frequency. Any stages between a sound takeoff and the video detector are designed to amplify only the video intermediate frequency.

To distinguish these two functions from each other, the stages and tubes carrying both intermediate frequencies may be called wide-band i-f amplifiers, input amplifiers, composite i-f amplifiers, or video-sound i-f amplifiers. We shall use the last of these names. Stages and tubes which carry only the video intermediate frequency are called video i-f amplifiers.

Considerable amplification must be applied to the video signal.

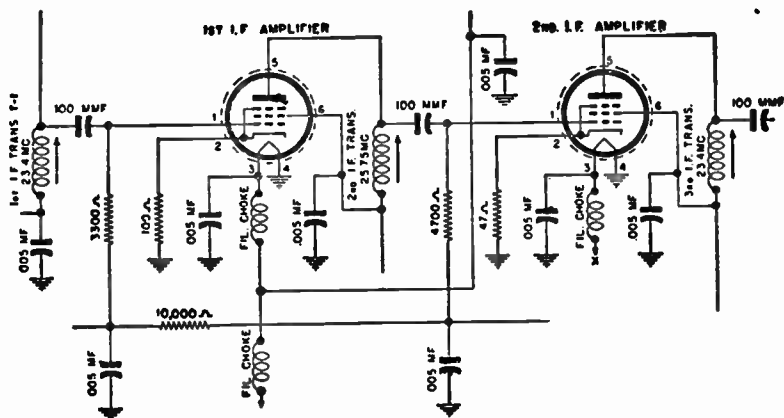

Fig. 5-1.—First and second video-sound i-f amplifiers using tuned impedance couplings. (Sentinel)

Because of the very broad frequency response in the tuner there can be but little gain in that section. Most of the gain is secured in the video and video-sound amplifying stages, of which there may be three or more in the television receiver.

Two video-sound i-f stages are shown in the diagram of Fig. 5-1. Interstage couplings are of the tuned impedance type, as in the majority of television receivers. The tuned coupling coils are in the plate circuits, with capacitor coupling to the control grids of following tubes. Tuning capacitances are provided by tube capacitances and distributed capacitances in the circuits. The first coupling coil, at the extreme left, is in the plate circuit of the mixer. The mixer tube is not included in this diagram. Similar coils are in the plate circuits of both tubes shown in the diagram.

Fig. 5-2 shows the third video-sound i-f amplifier and the video detector. Here the load in the amplifier plate circuit consists of

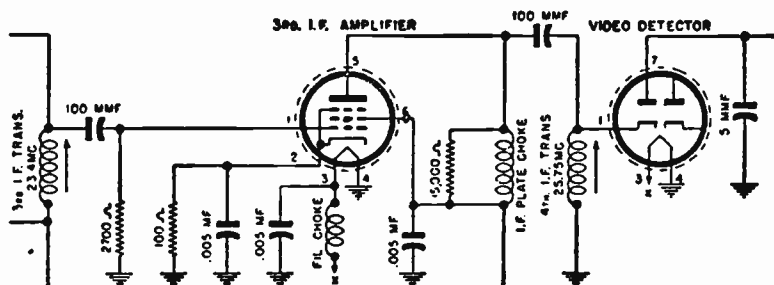

Fig. 5-2.—Third video-sound i-f amplifier and input to video detector. (Sentinel)

an untuned choke, with capacitor coupling to the cathode of the diode detector. Between detector cathode and ground is the tuned impedance coupling coil for this stage. In other receivers using tuned impedance couplings for the i-f stages the coupling coils may be in the grid circuits, capacitor coupled from the preceding plate circuit loads which consist of resistors or of resistors and untuned chokes.

Fig. 5-3 shows tuned transformer interstage couplings in a video i-f amplifier. These transformers are not overcoupled to provide a double peaked broad band response, as is general practice with i-f transformers for sound receivers. Rather the transformers are undercoupled so that they may be peaked quite sharply around a single frequency.

Connected across the primaries of the coupling transformers are fixed resistors. Such resistors are required wherever the construction and electrical proportions of the coils would, in themselves, produce a high-Q circuit with a resonance curve peaked too sharply for the needed band pass. Similar resistors sometimes are found in control grid circuits. These resistors broaden the frequency response and, of course, reduce the gain.

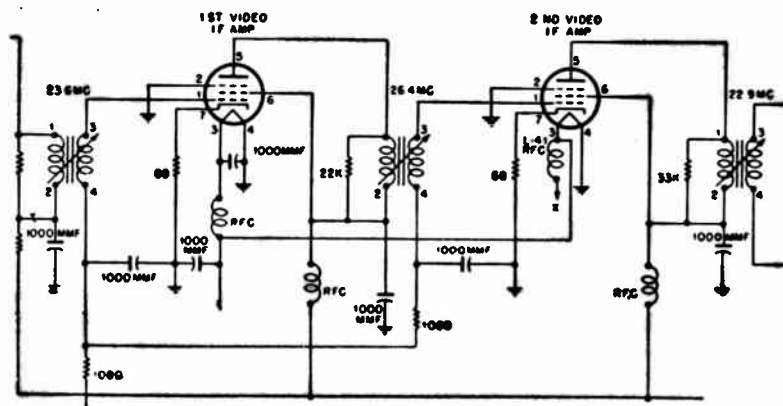

Fig. 5-3.—Tuned transformer couplings in a video i-f amplifier. (Motorola)

Still another band broadening method consists of using un-bypassed cathode-to-ground resistors. Omitting the bypass capacitor allows some degeneration, reduces gain at the tuned frequency, but also makes the response more uniform over a limited range of frequencies.

Receiver Attenuation.—You will recall that, during our examination of frequency distribution in a television channel, we found

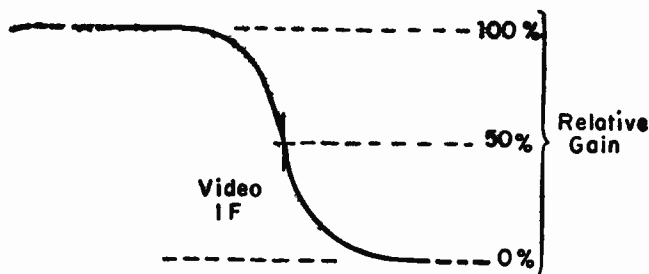

Fig. 5-4.—High-frequency end of a typical video i-f response curve.

the frequencies in the range from $\frac{3}{4}$ mc below to $\frac{3}{4}$ mc above the video carrier being transmitted in both the lower vestigial sideband and the complete upper sideband. That is, all frequencies within this range are transmitted in double strength. Correction is made by attenuation in the video i-f amplifier of the receiver by suitable shaping of the overall video i-f response.

You will find the normal overall frequency response of every video i-f amplifier is approximately as shown by Fig. 5-4, so far as the high-frequency end of the curve is concerned. The video intermediate frequency is, in theory, supposed to be half way down, 50% down, or 6 db down on the high-frequency slope of the curve. This curve is the combined response of all stages carrying video intermediate frequency, all the stages between mixer output and video detector input. It is not the response of any single stage.

The reason we require this kind of overall response is shown by Fig. 5-5. At the top is represented the strength of the transmitted signal with respect to frequencies at and near the video carrier frequency. Down below is represented an ideal overall response for the video i-f amplifier in the receiver. There is a

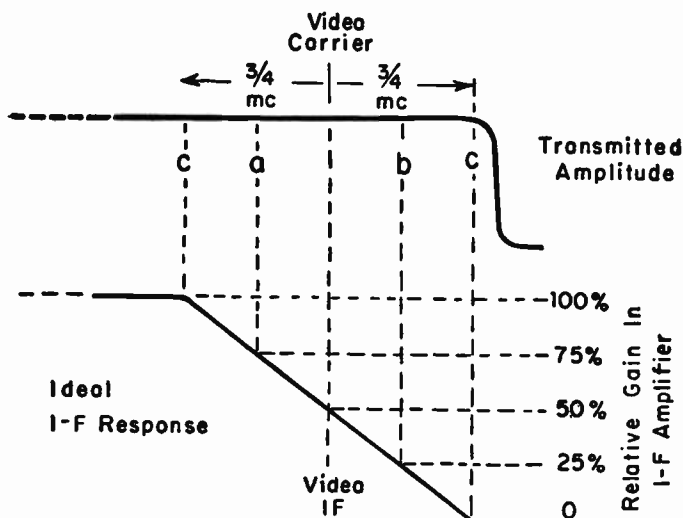

Fig. 5-5.—How double transmission of some frequencies is compensated for in the video i-f amplifier.

uniform downward slope from 100% gain or amplification at $3/4$ mc below the video intermediate frequency to zero at $3/4$ mc higher than this frequency. Such an ideal curve cannot be obtained in any ordinary receiver, but it can be approximated.

Consider what happens to a frequency at a in the upper sideband of transmission. This frequency receives 75% amplification in the video i-f amplifier. The frequency at b , in the vestigial sideband, is the same as the frequency at a in the upper sideband. The amplification for b is only 25%. Then the total amplification for a plus b (the same frequency) is 75% plus 25%, or is 100%.

Any other pair of like frequencies in the upper and lower sidebands receive such percentage amplifications as to add up to 100%, so all frequencies within the range of $3/4$ mc above and below the video carrier and video intermediate frequencies receive a total of 100% amplification. When we get to the left-hand frequency c there is 100% amplification. But the like frequency at c on the right gets zero amplification, so again the total is 100%. All frequencies to the left of c receive 100% amplification, but all these are singly transmitted.

Intermediate Frequencies in Use.—Video intermediate frequencies in the majority of television receivers are between 25.75 and 26.75 mc. Sound intermediate frequencies always must be 4.5 mc lower than video intermediates, so are in the range between 21.25 and 22.25 mc. There may be different intermediate frequencies in different models of receivers made by the same manufacturer. Some of the frequencies in more or less general use are listed in the accompanying table.

TELEVISION INTERMEDIATE FREQUENCIES, MC

Video	Sound	Video	Sound
25.75	21.25	26.4	21.9
25.8	21.3	26.5	22.0
26.1	21.6	26.6	22.1
26.2	21.7	26.75	22.25
26.25	21.75		

Tuning of I-f Stages.—When an interstage coupling consists of a single tuned coil in either the plate circuit of the first tube or the grid circuit of the second tube, the frequency response of this stage will show a single peak. When there are separate tuned

coils in the plate and grid circuits, with capacitor coupling from plate to grid, there may be a single-peaked frequency response or a double-peaked response. Two peaks may be secured by tuning the coils to different frequencies, or else by tuning to the same frequency and using tight coupling. With transformer coupling which is purely inductive the degree of coupling determines whether the response will show one or two peaks. All the i-f interstage couplings in one receiver may be single-peaked, all may be double-peaked, or there may be some of each kind.

To obtain an overall response shaped as required for the video i-f amplifier the successive stages are peaked at different frequencies. This is referred to as *stagger tuning*. For a simple

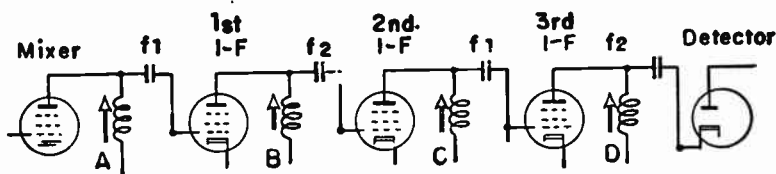

Fig. 5-6.—Four interstage couplings tuned alternately to two different frequencies.

illustration of the principle we may consider the i-f amplifier of Fig. 5-6. Here there are four single-peaked tuned couplings between the five tubes, from the mixer output to the video detector input. The four couplings always are tuned to frequencies in or close to the video i-f pass band of the receiver. Tuning often is to four different frequencies. Just as often there are only two frequencies, with two couplers tuned to one of these frequencies and the remaining two couplers tuned to the other frequency.

For our illustration we shall use only two frequencies, designated as f_1 and f_2 . Couplers A and C will be tuned to frequency f_1 , while couplers B and D are tuned to frequency f_2 . Adjacent couplers are not tuned to the same frequency, because with the same frequency on both plate and grid of the same tube there might be enough feedback to cause oscillation rather than amplification. We shall assume that the circuits are so designed that the shape of the response curve is the same for either frequency and in all stages.

At the top of Fig. 5-7 are shown the separate but similar responses or gains with coupling A tuned to frequency f_1 and

with coupling B tuned to frequency f_2 . When the output from A is put through the first i-f amplifier the amplitudes at the various side frequencies are subjected to the response or gain of coupler B and the second i-f amplifier. Then the combined response of the

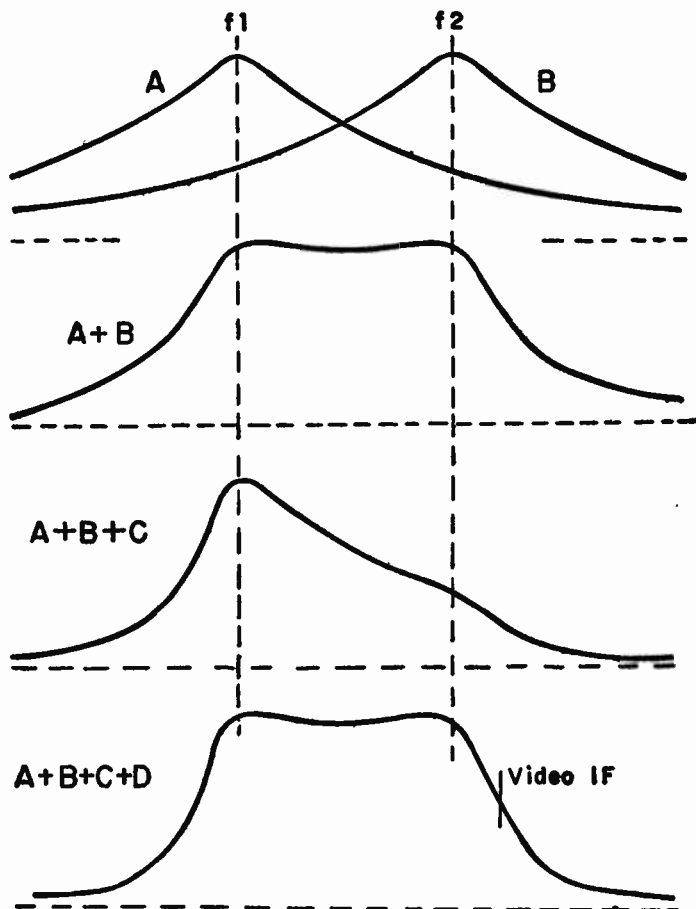

Fig. 5-7.—How two frequency responses combine in successive stages to produce an acceptable overall video i-f response.

two couplers, or the response from the mixer through to the plate of the second i-f amplifier, will be as shown by the curve marked $A + B$. Of course, the amplitude or voltage after two tubes in

cascade should be much greater than from either one alone, but all response curves are reduced to the same height for easy comparison.

Now the output from the first two couplers, as represented by the curve $A + B$, is acted upon by the frequency response of coupler C . This coupler is tuned to frequency f_1 and the shape of the response is the same as for coupler A shown up above. The result, and the frequency response as far as the grid or plate of the third i-f amplifier, is as shown by the curve marked $A + B + C$. So far we have done a fair job on the left-hand end of the response, the right-hand end is far down.

Final correction is made by subjecting the output of the third i-f amplifier, which follows curve $A + B + C$, to the frequency response of coupler D . This coupler is tuned to frequency f_2 and its gain is like that shown at the top of the graph. The peak at frequency f_2 brings up the right-hand end of the curve, while the small gain in this coupler at and near frequency f_1 has little effect on the left-hand end. The final result or the overall response is shown by the curve marked $A + B + C + D$ at the bottom of the graph.

By correct choice of tuned frequencies and of shapes of the original curves, the video intermediate frequency may be placed about half way down the right-hand slope of the overall response. Where the sound intermediate frequency should appear will depend on the type of sound system employed in the receiver or on the point at which there is sound takeoff. The individual response in any coupling may be altered as required by changing the loading and the Q -factor. Less loading, and high- Q construction in general, makes the response curve come to a sharper peak, increases the gain, and reduces the frequency pass band for the stage. More loading and a lower Q -factor have opposite effects.

When there are four i-f amplifier tubes and five tuned couplings, it is common practice to tune all five to different frequencies. Nearly always the five tuned frequencies lie somewhere within the limits of the sound and video intermediate frequencies. Fig. 5-8 shows three of the many frequency combinations in use, as they are related to the sound and intermediate frequencies of the particular receiver. The numbers refer to positions of the couplers having the various frequencies. Number 1 means the

coupler between mixer and first video i-f amplifier, number 2 means the coupler between first and second i-f amplifiers, and so on.

When there are five tuned couplings, the frequency for one of them usually is somewhere near the center of the range. This

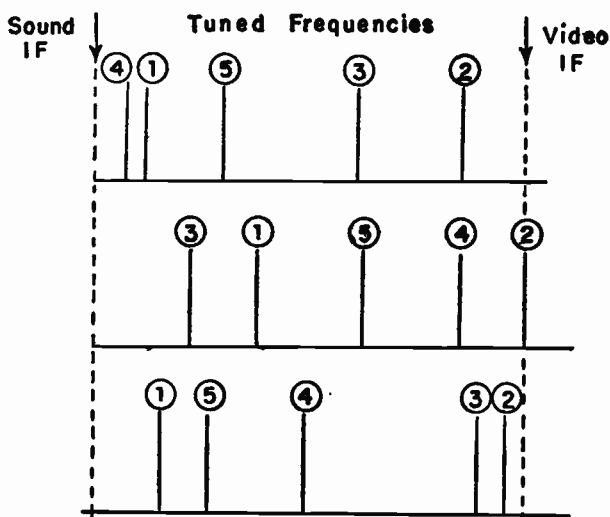

Fig. 5-8.—Some frequencies used with five tuned couplings, as related to the respective sound and video intermediate frequencies.

coupling, or its response, then eliminates most or all of the dip which often appears between two peaks in the overall response of other types.

Automatic Gain Control.—In television receivers the gain of one or more of the video i-f amplifiers, and often the gain of the r-f amplifier as well, are automatically controlled by strength of the received signal. Thus the input to the video detector is maintained at a nearly constant level during ordinary fluctuations of strength in the received signal. The purpose of this automatic gain control is to maintain correct brightness and contrast in the picture without need for continual readjustment of the controls during reception. This purpose is analogous to that of the automatic volume control in sound receivers, where the input to the detector is maintained nearly constant without continual resetting of the manual volume control.

88 APPLIED PRACTICAL RADIO-TELEVISION

Most of the television agc systems (automatic gain control systems) employ the same basic circuit principles found with automatic volume controls for sound. There is, however, a highly important difference between the source of the voltages which actuate automatic gain controls and those used for automatic volume controls.

The avc control in a sound receiver is actuated by the average amplitude of the rectified or demodulated audio signal. The amplitude of this rectified voltage tends to increase on strong incoming signals and to decrease on weak ones. The varying amplitude produces a correspondingly varying charge on a capacitor. The capacitor charge, and voltage, vary the control grid bias of i-f and r-f amplifiers, making the bias more negative for strong signals and less negative for weak ones.

In television we cannot utilize the average amplitude of the rectified video signal for control of gain. The reason is that this

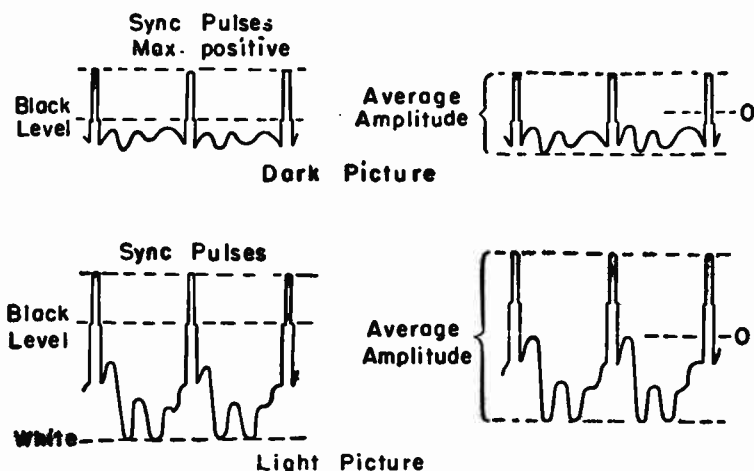

Fig. 5-9.—Average amplitudes of dark and light picture signals when restored to a-c form after detection.

average amplitude varies not only with strength of the received signal, but also with every variation of light and dark shading in the picture. A picture in which the objects or the background are largely dark in tone produces a signal as shown at the upper left in Fig. 5-9, with picture modulation remaining close to the

black level. When this signal passes through coupling capacitors it becomes an a-c voltage of rather small average amplitude, as shown at the upper right.

If objects or background in the televised picture are of such tones as to make the overall effect largely light, much of the picture modulation will remain near the white level, as in the diagram at the lower left. When this signal becomes an alternating voltage it has an average amplitude far greater than with the dark toned picture. This greater amplitude is shown at the right.

There is one characteristic of the signals which does not change with variations in light and shade. This is the voltage represented by the sync pulse peaks. These sync pulse peaks remain of constant strength unless there actually is fading or some other change in true strength of the received signal, as in the case of changing from one station to another. It is such variations of sync pulse voltage which are used for automatic gain control.

Fig. 5-10 represents a carrier signal or i-f signal before demodulation or rectification. Here it is plainly apparent that, so long as

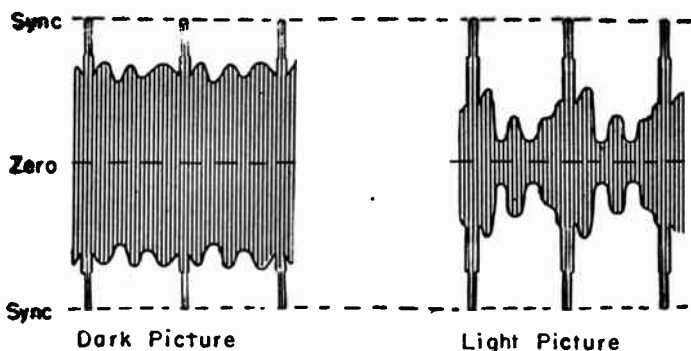

Fig. 5-10.—Voltages at the tips of the sync pulses are not altered by the tone or shading of the picture.

the strength or maximum amplitude of the received signal remains constant, the peak voltage at the tips of the sync pulses remains constant and with the same potential difference between it and the zero value of the a-c wave. If the entire received signal changes in strength the potential difference between zero and

sync peaks will change one way or the other, and the entire wave will shrink or expand proportionately. But variations in picture tone with signal strength unchanged have no effect on peak voltage of the sync pulses.

Fig. 11 shows a fairly common type of agc system employing peak voltage of the sync pulses. The agc tube is the left-hand section of a twin diode, whose other section is utilized as the video detector. This detector is included only because it is general practice to combine video detection and gain control elements within a single envelope.

The modulated output of the last i-f amplifier is connected to the plate of the agc diode through capacitor C_a . The signal envelope of one polarity passes freely through the diode and ground at

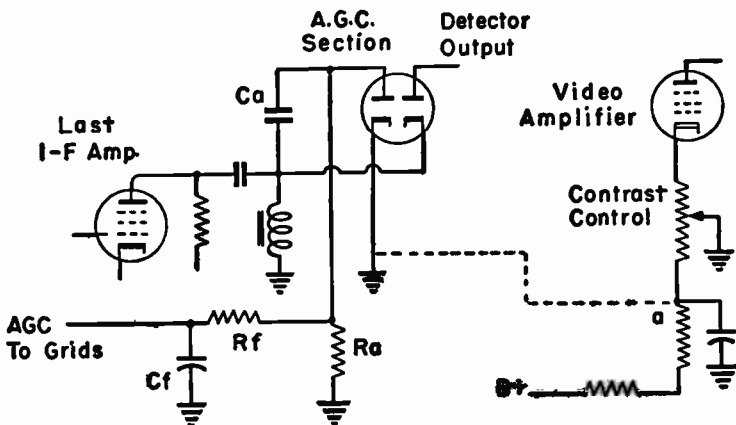

Fig. 5-11.—One type of automatic gain control employing the peak voltage of the sync pulses.

the cathode connection. The other side of the signal, or the opposite polarity, charges capacitor C_a . The charges of this polarity cannot escape through the diode, but can leak off the capacitor only through resistor R_a . The time constant of capacitor C_a and resistor R_a is so long that hardly any of the capacitor charge can leak off between recurring sync pulses. As a result, the voltage on capacitor C_a builds up to practically equal the peak voltage of the sync pulses. This peak voltage, which is also across

resistor R_a , is applied through the usual filter resistor and capacitor (R_f and C_f) to the agc bus leading to the control grids of whatever tubes are subject to automatic gain control.

Note that it is the long time constant of C_a and R_a that forces this system to operate on peak voltage of the sync pulse rather than on the average amplitude of the signal.

You are familiar with the fact that sound receivers often include delayed avc to prevent limiting action on weak signals. Delayed agc is used in television receivers for the same reason. To provide delayed agc with the circuit of Fig. 5-11 it is necessary only to apply a positive biasing potential to the cathode of the agc diode. This may be done by connecting the cathode as shown by the broken line rather than to ground.

The line coming from the B+ supply contains so much resistance that the remaining potential at point a , connected to the agc cathode, is only two or three volts positive with reference to ground. Whatever the potential at this point and the cathode, there will be no agc action until voltage built up from the sync pulses becomes greater than this delay potential. By connecting the B+ lead to ground through the contrast control on the video amplifier, adjustment of this control in the direction to provide greater gain in the amplifier tube also increases the delay voltage and permits full gain in the video i-f amplifier tubes and tuner r-f amplifier which are in the agc system.

There are other agc systems employing, in addition to the rectifier, an amplifier and sometimes additional diodes for strengthening and controlling the agc bias voltage. Adjustable sensitivity controls may permit regulation of the average agc voltage to best suit local reception conditions.

During alignment of video i-f stages it may be necessary to make the agc system inoperative and to apply in its place a fixed negative bias. This applies also to the alignment of the r-f amplifier when it is under automatic gain control. The only case in which this procedure is not called for is when the input from the signal generator and the amplification of stages following this input will surely not produce signal voltages causing the agc system to act. If the agc voltage does vary the bias of control grids, the response curves will be flattened so much as to make it difficult or impossible to align to the actual peak frequencies.

With most systems the agc action may be prevented by connecting a 3-volt dry battery between the agc bus and chassis ground, with the negative terminal to the chassis. If this fixed bias is to be adjustable a 5,000 ohm or 10,000 ohm potentiometer may be connected with its outer ends across a 4½-volt C-battery. Then the positive terminal of the battery is connected to chassis ground and the slider of the potentiometer to the agc bus. The bias voltage may be adjusted to a desired value with a high-resistance voltmeter connected between the agc bus and chassis ground.

Interference Traps.—When a receiver is tuned for a certain channel the limits of that channel are not far from carrier frequencies in adjacent channels. Fig. 5-12 shows the situation when

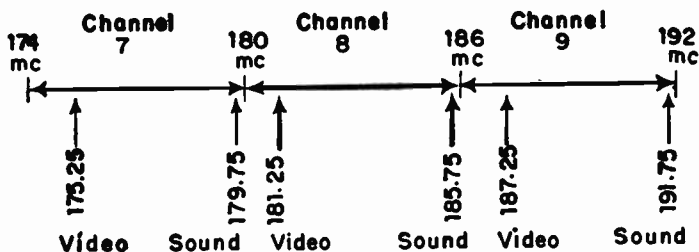

Fig. 5-12.—Sound and video carrier frequencies in a received channel and channels adjacent.

tuned for channel 8. The sound carrier of adjacent channel 7 is only 1½ mc below the video carrier in the tuned channel. The video carrier of adjacent channel 9 is only 1½ mc above the sound carrier in the tuned channel.

There are similar relations between tuned and adjacent carriers whenever the frequency limit of one channel is at the limit of an adjacent channel. Transmitters in the same locality do not operate in channels which are thus adjacent, but it is possible for a distant transmitter in an adjacent channel to cause more or less interference even though its signals are not received well enough to reproduce pictures and sound.

In Fig. 5-13 the full-line curve may represent the broad frequency response of a video i-f amplifier. This diagram shows also the relations of video and sound carriers in adjacent channels to video and sound carriers in the tuned channel. All these

frequencies now are intermediate frequencies, since they appear in the i-f amplifier. If the response is as broad as shown it may be necessary to greatly attenuate this response at the video and sound intermediate frequencies arising from carriers in adjacent channels. The response then must be shaped about as indicated by the broken line curves at opposite ends.

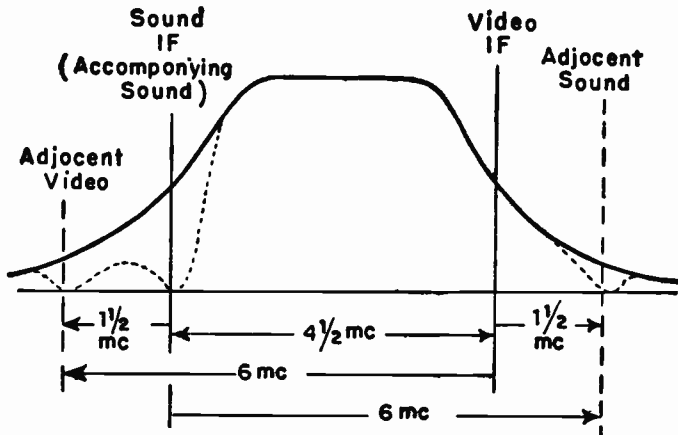

Fig. 5-13.—Adjacent sound and video frequencies as related to the video i-f response of a receiver.

The interfering frequency resulting from the video carrier in an adjacent channel is called the *adjacent video* frequency, and the one resulting from the sound carrier in an adjacent channel is called the *adjacent sound* frequency. Unless the receiver has an intercarrier sound system it is necessary also to attenuate in all stages following the sound takeoff the sound intermediate frequency of the tuned channel. This sound intermediate in the same channel with the received video signal is called the *accompanying sound* frequency or the *associated sound* frequency.

Looking back at Fig. 5-12, you will see that the adjacent sound frequency close to the received video frequency is in the lower channel, while the adjacent video frequency close to the tuned sound frequency is in the higher channel. Frequency relations are reversed by action of the r-f oscillator, as pointed out in earlier pages. Consequently, although the adjacent video in Fig. 5-13 is at a frequency lower than the accompanying sound, this adjacent

video frequency comes from a higher channel. Although the adjacent sound of Fig. 5-13 is higher in frequency than the received video, this adjacent sound comes from a lower channel.

Interfering frequencies are attenuated by wave traps of many types, all serving the same general purpose of removing the unwanted frequencies before they reach the video detector. A few of the trap circuits which are in general use are shown by Fig. 5-14. At A the coil of the trap circuit is inductively coupled to the stage tuning coil between the two video i-f amplifiers. The stage tuning coil is aligned for the peaked frequency used for coupling, while the trap is tuned to the interference frequency to be attenuated at this point. The trap is tuned quite sharply to the interference frequency. It absorbs energy at this frequency from the stage tuning coil, and the energy is dissipated in resistance of the trap circuit. Were the stage tuning coil in the control grid circuit the trap would be similarly coupled to that coil.

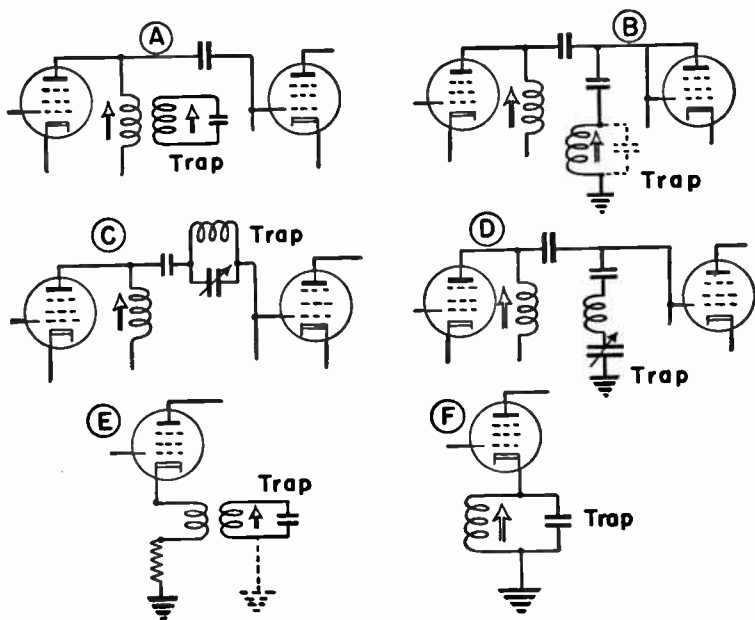

Fig. 5-14.—Wave trap circuits used for adjacent sound and video, and for accompanying sound frequencies.

At *B* the trap consists of a parallel resonant circuit coupled to the grid side of the interstage coupling through a small capacitor. At the interference frequency to which the trap is sharply tuned, strong circulating currents flow between trap inductance and capacitance. Energy is absorbed from the interstage coupling at this frequency and is dissipated in trap circuit resistance and to ground if there is a ground connection as shown.

Diagram *C* shows a parallel resonant trap circuit connected in series between the plate of the first tube and the control grid of the following tube in the amplifier. At the interference frequency to which the trap is sharply tuned it provides maximum impedance, but at frequencies both higher and lower the trap impedance is small. At *D* there is a series resonant trap connected to the same point in the interstage coupling as the parallel resonant trap of diagram *C*. The lower end of the series resonant trap is grounded. At its tuned interference frequency this latter trap has minimum impedance and bypasses the unwanted frequency to ground. At higher and lower frequencies the trap impedance is high to prevent draining off these frequencies.

In diagram *E* a parallel resonant trap is inductively coupled to a coil between cathode and ground from the amplifier tube. Because both the plate circuit and the control grid circuit of a tube pass through its cathode-to-ground path, this trap absorbs its tuned interference frequency from both the plate side and grid side of the tube. The trap circuit may or may not be grounded, and it may be tuned either with a slug in the coil or with an adjustable capacitor.

Diagram *F* shows a parallel resonant trap in series with the cathode-to-ground path of an amplifier tube. Any parallel resonant trap has maximum impedance at its tuned frequency. Consequently, tube currents at this trap frequency are strongly impeded, while currents at higher and lower frequencies have relatively free flow through the inductance or capacitance of the trap.

Trap circuits such as illustrated, and modifications of them, may be found anywhere between mixer and video detector, and sometimes in the cathode circuit of the detector. Ordinarily there will be no more than one trap on any one coupling circuit, but there may be traps on any or all the coupling circuits. Usually

there will be no more than one trap tuned for adjacent sound, and no more than one for adjacent video, or there may be no traps tuned to these frequencies. When any traps are used there will be at least one tuned to the accompanying sound frequency, and often there are two or more tuned to this frequency.

There will be no traps for accompanying or associated sound in a receiver employing the intercarrier sound system, because the sound signal must be carried through the video detector.

Traps of the types mentioned are not required or provided where the video i-f response may cover a rather narrow range of frequencies and may be made more highly selective in itself due to this narrower band. This is the case with receivers using direct view picture tubes in sizes smaller than 10-inch diameter. As explained earlier, the picture definition or detail in the smaller tubes is ample with a frequency range around 3 mc. In any case where the characteristics of the video i-f amplifier are such as to provide steeper sides on the overall response than shown by Fig. 5-13, traps may be unnecessary.

A sharply tuned sound takeoff coupled to any point along the i-f amplifier removes more or less energy at the accompanying sound frequency, and acts somewhat in the manner of a trap for this frequency. In no receiver will there be traps for the accompanying sound anywhere between the mixer and the sound takeoff, because the sound signal must reach the takeoff point. Any traps for accompanying sound must be between the sound takeoff and the video detector, or in the detector circuit.

Frequencies to which traps should be tuned for adjacent sound or adjacent video are easily determined when knowing the video intermediate, sound intermediate, or both these intermediate frequencies for the receiver. As may be seen in Fig. 5-13, the adjacent video frequency is $1\frac{1}{2}$ mc lower than the accompanying sound and 6 mc (one channel width) below the receiver video intermediate. The adjacent sound frequency is $1\frac{1}{2}$ mc higher than the receiver video intermediate and 6 mc higher than the receiver sound intermediate frequency.

When a receiver is tuned to certain channels there can be no adjacent sound interference, and when tuned to certain other channels there can be no adjacent video interference. This is due to the fact that there are no immediately adjacent television

transmission frequencies below and above some channels, as shown by the frequency diagram of Fig. 5-15.

Adjacent sound interference must come from a channel immediately below the one to which the receiver is tuned. There

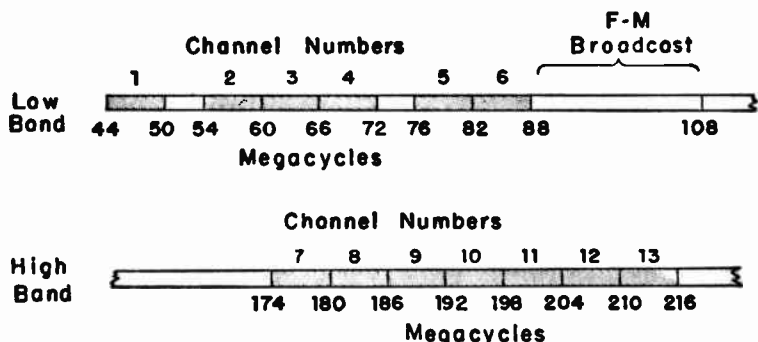

Fig. 5-15.—Frequency limits in the low band and high band television channels.

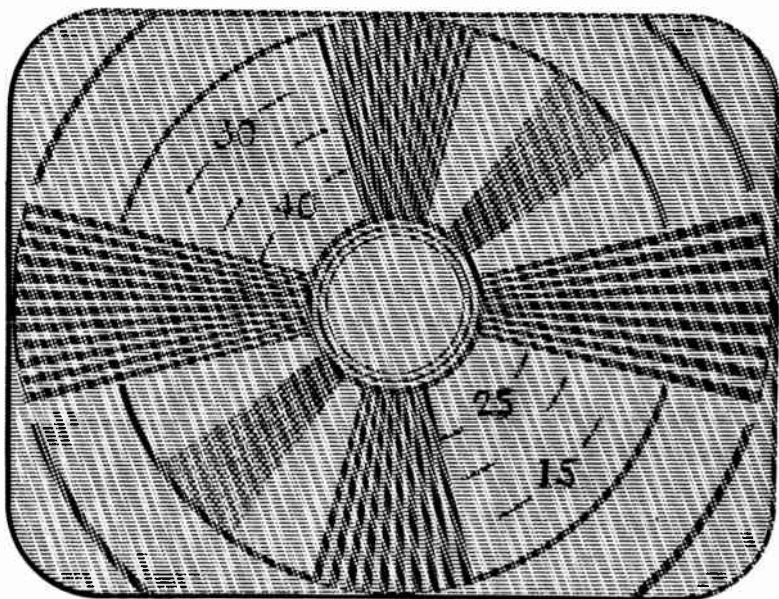

Fig. 5-16.—Effect of high-frequency interference experienced in some television channels.

are no television transmissions immediately below channels 2, 5 and 7. So when tuned to these channels there will be no adjacent sound interference. There is no television transmission immediately above channels 1, 4, 6 and 13, and on these there will be no adjacent video interference.

Immediately above channel 6 is the f-m sound broadcast band. There are various kinds of short-wave or high-frequency radio transmissions in between channels 1 and 2, between 4 and 5, below channel 6, and above channel 7. There may be, and often is, interference from these transmissions. The extent of interference depends on how close a transmitter may be, and on its operating frequency. The result in a pattern on the picture tube is much as shown by Fig. 5-16. Fine sloping or vertical lines weave back and forth across the pattern or picture, varying with modulation on the interfering signal.

If the interfering frequency can be determined, by measurement or cut and try methods, it may be reduced or eliminated by a trap at the antenna circuit of the receiver. Several such traps are shown by Fig. 5-17. At A the trap consists of a series resonant circuit connected between the antenna terminals of a receiver

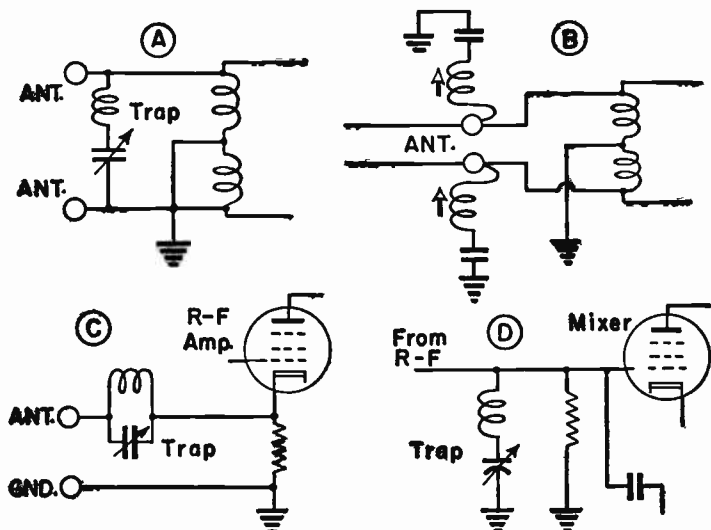

Fig. 5-17.—Interference traps used at antenna terminals and in the tuner.

fed from a balanced 300-ohm transmission line. The trap shorts out the interference frequency to which it is tuned. Another trap connected to the antenna terminals used for a 300-ohm balanced line is shown at *B*. From each terminal or each side of the line there is a series resonant trap circuit to ground. Both circuits are tuned to the interfering frequency, which they bypass to ground through their low impedance at this particular frequency.

With a 72-ohm unbalanced transmission line a trap may be connected as in diagram *C*. The trap is a parallel resonant circuit in series with the ungrounded side of the transmission line, which is the central conductor of the cable. At the interfering frequency, to which the trap is tuned, there is maximum impedance and reduction of signal strength. Sometimes, as at *D*, a series resonant trap circuit is connected from the mixer control grid to ground. The minimum impedance at the interference frequency, to which the trap is tuned, bypasses this frequency to ground.

All antenna traps must be of high-*Q* construction to have a resonance curve sharp enough to prevent cutting out too much of the desired signals. It is difficult to design an efficient trap which may be adjustably tuned anywhere within the overall range of television channel frequencies, although some traps will cover either the low band or else the high band. No antenna trap of any kind should be needed for a receiver having circuits tuned for each channel between the antenna input and the r-f amplifier grid-cathode circuit.

Because of the high frequencies used for intermediates in television there is no danger of image interference such as may occur in the f-m sound broadcast receivers. Any interfering image frequency would be equal to the sum of the r-f oscillator frequency plus the intermediate frequency. The sum of these two frequencies with the receiver tuned for any channel between 1 and 6 will be above the highest carrier frequency in this low band and below the lowest carrier frequency in the high band. Similarly, when tuned for channels 7 through 13, the sum of the oscillator and intermediate frequencies is higher than the highest carrier frequency in the band. Image frequencies for the low band will, however, fall within the f-m broadcast band. Image interference from this latter source is reduced or eliminated by

suitably tuned couplings between antenna and r-f amplifier, or may be handled by some of the antenna traps if it occurs from some one f-m channel.

Somewhat similar to image interference is a type of television interference which originates from transmission in channel 7 when the receiver is tuned to channel 5, or which originates from channel 10 when the receiver is tuned to channel 6. This *inter-carrier interference* does not occur in any other pair of channels.

The explanation is as follows: Assume a receiver having a video intermediate frequency of 26.10 mc, tuned to channel 5 wherein the video carrier is at 77.25 mc. Then the r-f oscillator frequency must be the sum of these two, which is 103.35 mc. The tuner of the receiver, when set for channel 5, must respond to all the frequencies in this channel, which extend from 76 to 82 mc. If there is any other received signal which can beat with the r-f oscillator frequency to produce a difference frequency between 76 and 82 mc, the r-f amplifier may amplify this difference frequency. The sound carrier in channel 7 is at 179.75 mc. Subtracting the r-f oscillator frequency (103.35 mc) from this sound carrier frequency gives a difference of 76.40 mc, which is just within the range of frequencies handled by the r-f amplifier of the receiver considered.

A similar example worked out for channels 6 and 10 will give similar results so far as interference is concerned. If the video intermediate frequency is higher than 26.5 mc the interference frequency will come outside the theoretical r-f response by a margin equal to the difference between the actual video intermediate frequency and 26.5 mc. This class of interference, when it does occur, may be reduced or eliminated by an antenna trap tuned to the interfering frequency.

Traps for Intercarrier Beat.—The intercarrier beat frequency of 4.5 mc used as the carrier in the sound section of intercarrier sound systems may be troublesome in receivers using other sound systems. If this 4.5 mc beat frequency reaches the picture tube it will act with the horizontal scanning frequency of 15,750 cycles per second to produce about 280 thin vertical lines on the picture or pattern.

Since the intercarrier beat frequency originates in the video detector, by combination of the video and sound intermediate fre-

quencies, it may be removed or prevented only in circuits between the detector and the picture tube. Traps tuned to 4.5 mc may be used anywhere in these circuits. As shown by Fig. 5-18, a 4.5 mc trap may be between the video detector and first video amplifier, or between the first and second video amplifiers when two are

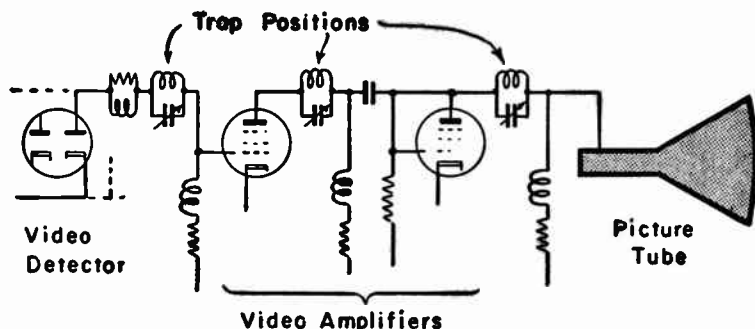

Fig. 5-18.—Traps used for the intercarrier beat frequency.

used, or between the video amplifier and the picture tube input. Usually a trap for intercarrier beat would be used at one or the other of these positions, not all of them. All the traps are parallel resonant types, sharply tuned to provide maximum impedance at the troublesome frequency and minimum impedance at all other frequencies.

The intercarrier beat frequency should not reach the picture tube in receivers having intercarrier sound systems any more than with other sound systems. Most of the takeoffs for intercarrier sound provide effective trap action against passage of the beat frequency beyond the takeoff point.

As mentioned several times before, receivers with picture tubes of moderate diameter do not require video frequency response extending much if any above 3 mc. If the response of the video amplifier section drops to a very low value at frequencies lower than 4.5 mc the intercarrier beat will not be amplified in this section and will not reach the picture tube. When such receivers use the sound intermediate frequency rather than intercarrier beat for their sound i-f amplifiers, the frequency response of the video i-f amplifier stages after the sound takeoff need not extend

much beyond 3 mc. Then the sound intermediate frequency does not reach the detector and cannot combine with the video intermediate to produce the 4.5 mc intercarrier beat.

Chapter 6

ALIGNMENT OF VIDEO I-F AMPLIFIER

Television service manuals usually give much attention to alignment of the video i-f amplifier, the sound section, and the tuner. This attention is warranted, because the difference between good and poor reception is the difference between correct and incorrect alignment—provided everything else is in good order. But you should not conclude that every case of trouble will be cleared up by realignment, for the chances are that the real fault is something easier to correct.

Alignment actually may be required when oscillator or amplifier tubes are replaced. It is required when parts of tuned circuits have been replaced, especially if replacement has been with other than exact duplicates. Alignment is needed also when parts or wiring in tuned circuits have been displaced or misplaced by poor servicing. Finally, it is quite possible that realignment may be needed after many months of operation, for there is gradual change in characteristics of tubes and in some resistors and other parts as they age.

Before undertaking realignment you should make every reasonable check to determine that the fault can be nowhere else. Test patterns or pictures should be observed. You should look at overall response curves and, if the kind of trouble points that way, you should look at some waveforms in the sync and sweep sections. Equipment needed for these observations will be called for anyway during alignment, if alignment really is required, and might as well be used first for preliminary tests.

The difficulty would not be removed by realignment if all signals are weak, so examine the antenna and transmission line. Tubes must be supplied with voltages at least fairly close to those normal for the circuit, so it is well to measure potentials at plates, screens, control grids, and cathodes. Only when no other fault or faults are discovered during all these checks should you consider alignment.

Alignment adjustments are made in any or all of the three

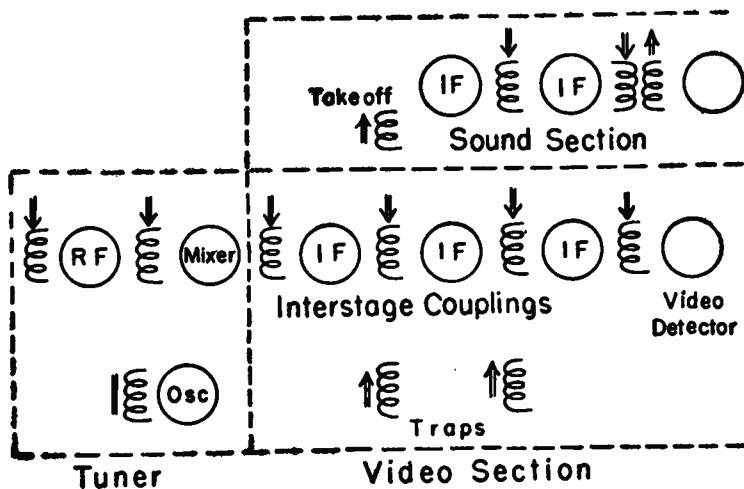

Fig. 6-1.—Points at which alignment may be required.

major sections of Fig. 6-1; the tuner, the video i-f amplifier, and the sound section. In the video i-f amplifier the two principal divisions of the work are adjustment of any traps which may be used, then of the tuned interstage couplings. In the tuner there always are adjustments for the r-f oscillator, also for the r-f to mixer coupling and sometimes for the antenna to r-f couplings on some or all channels. In the sound section there are adjustments in the demodulator or detector transformer, in the i-f amplifier, and maybe in the takeoff.

In our discussion of alignment methods we shall take up first the video i-f amplifier, then the sound section, and finally the tuner. This is not necessarily the order in which you would handle these sections should all of them need attention. If preliminary observations and tests lead to the conclusion that a particular section is in trouble, that is the section to work on first. If the picture is good and the sound poor you would commence with the sound section, although misalignment of the r-f oscillator might bring about this condition. With a poor picture and good sound it would be in order to begin with a check of the video i-f amplifier. With both picture and sound classed as poor, the tuner would be the first point of attack.

Alignment Practices.—There are a few things which apply in

a general way to all alignment jobs These we shall consider now. First is the matter of making connections between signal generators and tubes in the receiver. When working in the video i-f and sound sections it nearly always is necessary to couple the signal generator or generators to the control grid of a tube somewhere ahead of the parts to be adjusted. It is not always easy to reach the control grid pin on a socket without disturbing other connections or taking a chance of short circuits on other pins or connections. There are various ways of overcoming such difficulties.

Some technicians remove the tube from its socket, wind a couple of turns of fine wire around the grid pin and replace the tube with precautions that the added wire does not touch chassis metal. Insulated wire may be used, with the end bared, or small spaghetti may be slipped over a bare wire. The generator then is coupled to the exposed end of the wire. Often it is recommended that a small wire be soldered to the grid pin. With miniature tubes there is much danger that the soldering heat and expansion of the pin will crack the glass envelope, especially when the lead wire is placed high enough on the wire to allow replacement in the socket openings.

Often there will be some small opening in the chassis through which you can insert an insulated wire with its end bared and hooked to catch over a grid lead. Retaining in the shop a set of tubes of types commonly used, with permanent connections soldered to their grid leads, is not always satisfactory because the internal capacitances of these tubes may be enough different from capacitances of the receiver tubes to upset the tuning.

With still another method a close fitting tube shield is slipped part way down onto the tube to which a signal is to be applied, then the output lead of the generator is clipped to the shield. The shield must not touch chassis metal. There is a small capacitive coupling through the glass of the tube envelope. This coupling is sufficient where the signal will pass through several stages before going to the oscilloscope or electronic voltmeter, or where the generator has high output. Instead of a tube shield you can clip the generator output lead to a ring of brass or aluminum about a half inch wide, which is easily cut and rolled into shape from any thin metal. This ring should be pushed down over the

tube until it surrounds the internal elements. No capacitor or resistor is needed in series with the generator lead when coupling through a tube shield or a metal ring.

Between the attenuator in the signal generator and the control grid of the tube used for signal input must be a capacitor. Otherwise the grid bias will be shorted through the attenuator. Most generators have a capacitor in series with their output lead. It

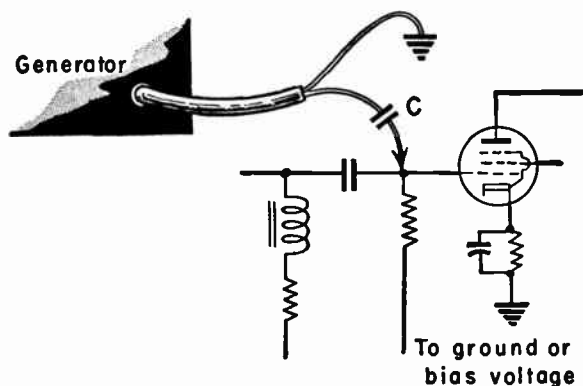

Fig. 6-2.—Use a small capacitor in series with the generator output lead and the connection to a control grid.

is safe practice to use an external capacitor, as shown at *C* in Fig. 6-2. A capacitance of 10 to 20 mmfd should be plenty if the generator provides a reasonably high output voltage.

In many receivers there are conveniently placed test jacks connected internally to points where signal generators should be coupled, also to points at which connection should be made to the oscilloscope or electronic voltmeter during alignment adjustments.

To avoid the risk of high-voltage shocks it is rather common practice to remove the high-voltage rectifier tube from its socket during alignment. This assumes that the rectifier furnishes voltage for only the picture tube anode or anodes. When the picture tube is removed from the chassis when taking the chassis out of its cabinet, alignment may be carried out without the picture tube. In some shops there are bench mounts in which the picture tube may be held while connected to the receiver, or picture tubes of common types may be permanently mounted on the test shelf and

connected to receivers being serviced. If the high-voltage rectifier is not removed while the picture tube is out of the chassis, the lead or leads for high-voltage anodes and deflection plates must be thoroughly insulated — usually with rubber caps held securely on the ends of these leads.

In our earlier discussion of automatic gain control it was mentioned that this control system either should be replaced with a fixed bias from a battery or else the signal input kept so low that bias voltage cannot be automatically increased. It is unsafe to simply ground the agc bus unless all tubes connected to it have fixed minimum biases provided by grid resistors or cathode resistors. Then the input signal must be kept weak enough that the control grid of no tube can be driven positive. A fixed bias of 2 to 3 volts, from a battery, usually will allow plenty of gain in the tubes while preventing any effect from the automatic gain control. These precautions in relation to automatic gain control apply when aligning the video i-f amplifier and also when aligning the tuner if the r-f amplifier or mixer is under automatic

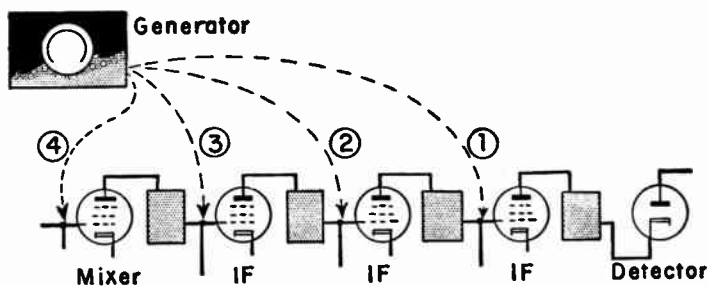

Fig. 6-3.—The generator coupling may be moved back toward the mixer, stage by stage, as alignment proceeds.

control. Sound avc, when used, is similarly disabled or overridden when aligning the sound section.

Make certain that ground connections are made at all points where required. Check for grounds from a ground terminal to the metal bench or shelf top at every instrument; signal generators, oscilloscope, and electronic voltmeter. Be sure that all shielded cables are grounded on the receiver chassis. Remember that any change in indications of the scope or the voltmeter when

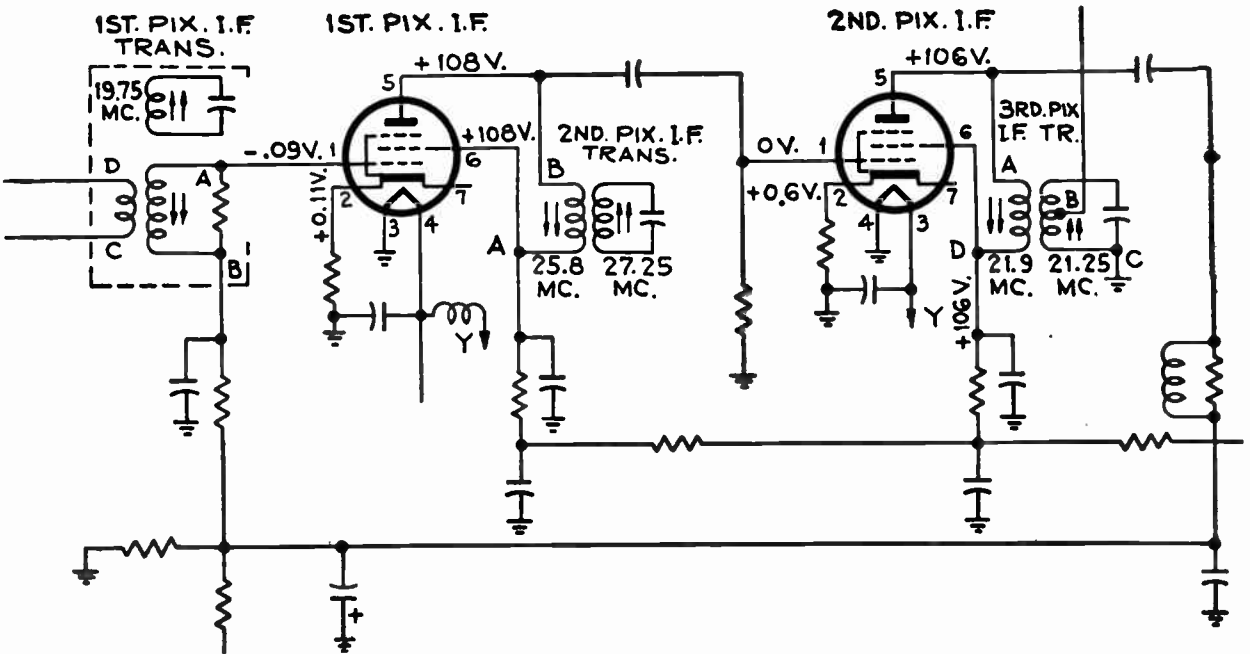

Fig. 6-4.—The first and second IF stages for video and sound in an RCA receiver.

touching any part of the receiver chassis indicates the need for additional grounding.

With everything connected and checked, turn on the power for the receiver and all the instruments to be used. Let all of them warm up for at least 10 minutes, preferably longer, before making any adjustments.

Alignment of Traps.—As a general rule any interference traps coupled to video i-f stages or video-sound i-f stages should be aligned before adjustment of the couplers in this amplifier. The reason is that any change in the tuning of a trap usually alters the frequency response of the interstage coupler associated with the trap, and when traps are tuned after completing alignment of the interstage couplers it will be necessary to realign the couplers.

This general rule should be followed when the generator used for alignment remains coupled to the control grid of the mixer tube during adjustment of traps in all following stages. There may, however, be an exception to the rule when the generator coupling is made first to the i-f tube preceding the detector, as in Fig. 6-3, and is moved back stage by stage as alignment proceeds. Then, in each stage which immediately follows the generator coupling, the trap and then the interstage coupling may be aligned before moving the generator back to the stage next ahead. With this method you would tune each trap as you come to it during alignment of the i-f couplers.

Fig. 6-4 shows the first and second i-f stages of a typical receiver employing traps for interference reduction. For this receiver the video intermediate frequency is 25.75 mc and the sound intermediate frequency is 21.25 mc. The interstage coupler at the left is between the mixer and the first i-f tube. To this coupler is inductively coupled a trap tuned to 19.75 mc. This frequency is just 6.0 mc lower than the video intermediate of the receiver, so this trap is for the adjacent video frequency.

On the coupler between first and second i-f tubes is a trap tuned to 27.25 mc. This is 6.0 mc higher than the sound intermediate of the receiver, so here we have a trap tuned for adjacent sound. On the coupler following the second i-f tube is the sound takeoff which is tuned to 21.25 mc, the sound intermediate frequency of the receiver. While removing the sound signal from

2ND. DET.

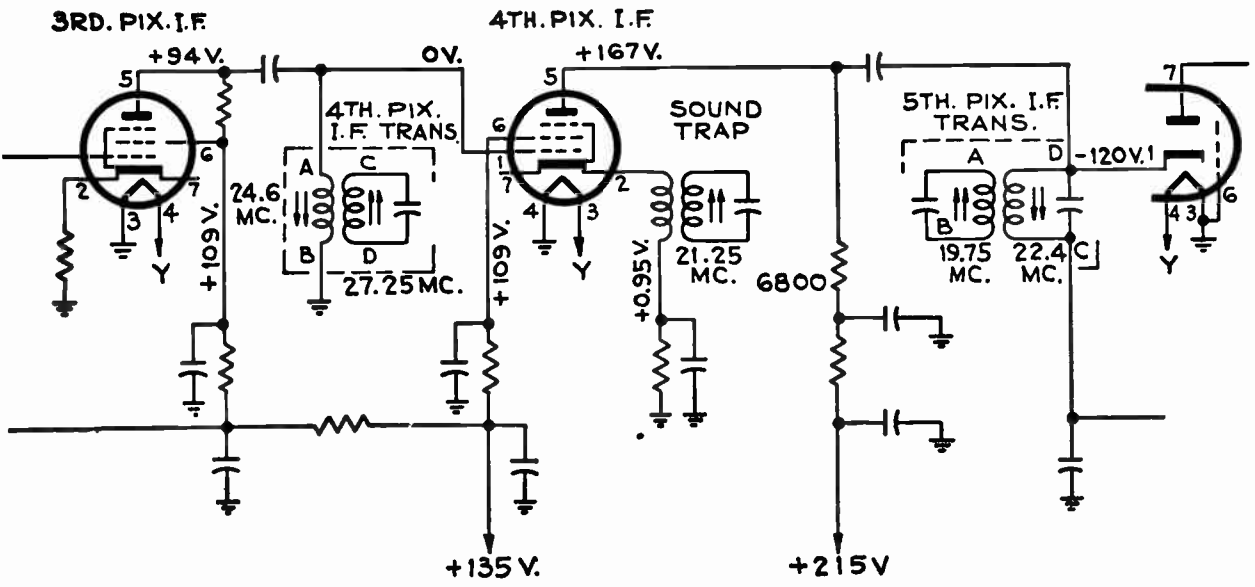

Fig. 6-8.—Third and fourth I.F. stages and second detector of the RCA receiver.

this coupler the takeoff circuit also reduces the strength of the accompanying sound which goes on to following stages. Note especially that there are no traps for accompanying sound ahead of the sound takeoff, although there are two traps for other frequencies ahead of this point.

Fig. 6-5 shows the third and fourth i-f amplifiers and the second detector or video detector of the same receiver. On the coupling between the third and fourth i-f tubes is a trap tuned to 27.25 mc, which is the same frequency as for the trap following the first i-f tube. Here, then, we have another trap for adjacent sound. Inductively coupled to the cathode-ground lead of the fourth i-f amplifier is a trap tuned to 21.25 mc. This is a trap for accompanying or associated sound signals which may have gotten past the sound takeoff, and which here are absorbed before going on to the second detector and picture tube.

The final trap in the i-f amplifier section is on the interstage coupler between the fourth i-f amplifier and the cathode of the second detector. This trap is tuned to 19.75 mc, which is the frequency of the adjacent video signal. If we count the sound takeoff as a trap, there are six in all. Two are tuned for accompanying or associated sound, one being the sound takeoff. Two

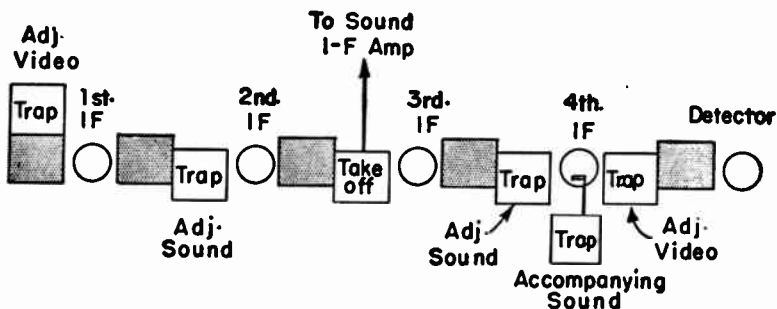

Fig. 6-6.—Locations of the six traps in the video-sound i-f amplifier.

more are tuned for adjacent sound (27.25 mc) and two are tuned for adjacent video (19.75 mc). All these traps are shown in the simplified block diagram of Fig. 6-6.

For alignment of traps in a video and video-sound i-f amplifier section the steps are as follows. Connections for instruments are shown by Fig. 6-7.

116 APPLIED PRACTICAL RADIO-TELEVISION

1. Use only a single-frequency signal generator, such as the marker generator, without any sweep generator. Couple the output of the generator through a small capacitor to the control grid of the mixer tube. The generator signal should be modulated with whatever audio frequency is provided, usually 400 or 1000 cycles.

2. Connect the electronic voltmeter between the output of the video detector and chassis ground or B—. The output of the video detector may be from either its plate or cathode, whichever is not connected to the preceding i-f coupler. In series with the out-

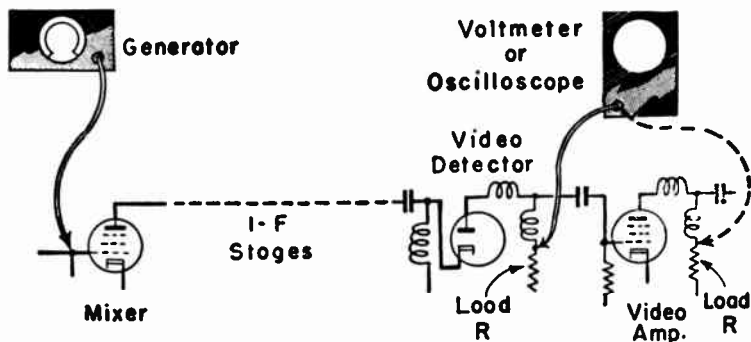

Fig. 6-7.—How the instruments are connected for alignment of traps.

put element of the detector will be an r-f choke, sometimes with a paralleled resistor, and somewhere following the choke will be a resistor going to ground or B—. This latter resistor is the detector load. Connect the high side of the voltmeter to the high side or detector end of this load resistor. Incidentally, the r-f choke really is a peaking coil, but it is built like r-f chokes with which we are familiar. Use the lowest scale or the most sensitive scale of the meter.

Instead of the electronic voltmeter you may use the oscilloscope as an output indicator. Use a filter probe on the vertical input of the scope, or connect a 10,000-ohm fixed resistor in series with the vertical input lead. If the scope is not highly sensitive, connect its vertical input lead to the high side of the video amplifier load resistor. This adds the gain of the video amplifier. Use the internal sweep of the scope, set for the modulation frequency provided from the signal generator.

3. Disconnect the antenna or transmission line from the receiver. Set the channel selector to some channel in which there is no local transmission, usually to one of the high-frequency channels.

4. Place the contrast and brightness controls in their usual operating positions. The contrast may be turned higher to give additional gain provided this does not cause oscillation in the i-f tubes during alignment.

5. Tune the signal generator to the exact frequency at which a trap is to be aligned. Increase the generator output to give a

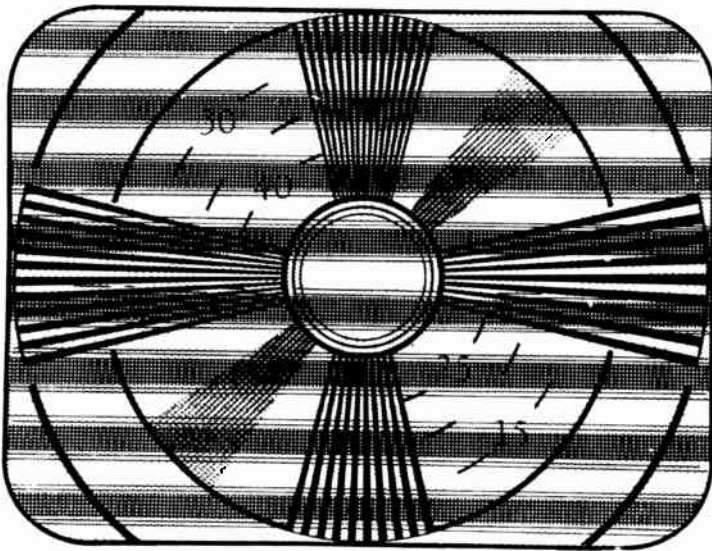

Fig. 6-8.—Sound bars on the screen of the picture tube.

good indication on the voltmeter or scope. Carefully adjust the trap to bring the indication as low as possible. As adjustment proceeds, increase the output from the generator. The object is to have maximum attenuation and minimum indication on the meter or scope with a high output from the generator tuned to the trap frequency. Change the generator tuning to the frequency of the next trap to be aligned, and adjust this trap for minimum reading on the indicator with high output from the generator. Align all remaining traps in the same manner.

If the modulation frequency of the signal generator goes

through the video detector and amplifier to the picture tube it will produce on the screen of this tube a series of horizontal "sound bars" about as shown in Fig. 6-8. These sound bars may be used as an indicator during trap alignment. The trap to whose interference frequency the signal generator is tuned should be aligned to get rid of the sound bars on the picture tube screen, or to reduce them to the greatest possible extent. As with other methods, the output from the modulated signal generator is increased as the alignment proceeds.

Traps are to be aligned for the sole purpose of reducing or eliminating troublesome frequencies. With traps correctly aligned, these frequencies on the response curve will be down at zero or nearly so. This effect varies the shape of the response curve by bringing it steeply downward near the trap frequencies. But trap alignment must not be used in an attempt to shape the response to bring the video intermediate frequency half way down its slope, or for any other shaping of the response other than is incidental to reduction of response at the trap frequencies.

Video I-f Alignment.—The object of aligning the couplers in the video i-f amplifier is to secure in the output of the video detector a response having some or all the features shown in Fig. 6-9. This curve applies particularly to a receiver not using intercarrier sound, and having a band width great enough to require traps for accompanying sound, adjacent sound, and adjacent video frequencies. The smaller receivers do not accept so wide a band and do not need the traps in most cases. When using intercarrier sound there are no traps which fully attenuate the accompanying sound, and usually no traps for either adjacent sound or adjacent video.

The most important feature is correct positioning of the video intermediate frequency on the response. Theoretically, this frequency should be 50 per cent down from peak response. Actually it may be anywhere between 30 per cent and 50 per cent down, which means at a point between 50 per cent and 70 per cent of peak response. The choice depends on make and model of receiver, and on the position with which there is best reception. If the video intermediate frequency is too far down, the response to low frequencies in the signal may be weak enough to make synchronization difficult and all pictures may appear dull and

lifeless. If this frequency is too high on the response there will be loss of detail or sharpness in the pictures.

When traps are used they must cause dips in the response at frequencies to which the traps should be tuned. Where the traps reduce the response nearly to zero the marker pips for identifying the trap frequencies will be almost or wholly invisible. A marker can be made to show up only on frequencies where there

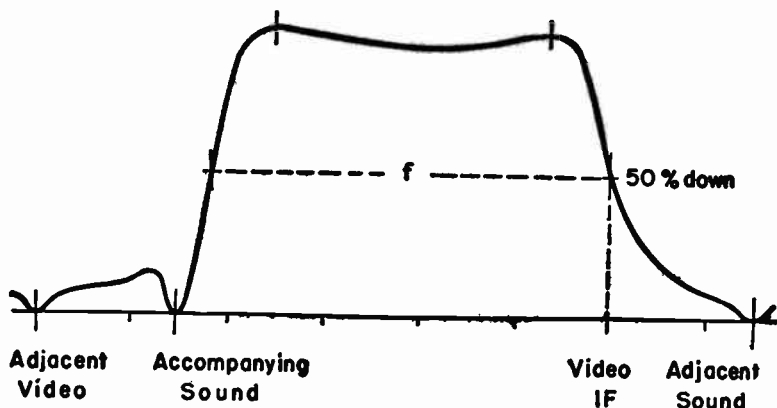

Fig. 6-9.—An overall response of a video I-f amplifier.

is at least some gain in the amplifier. The trap frequencies can be identified by tuning the marker generator to frequencies slightly above and below the trap frequency, where the pips can be seen, and estimating the frequency in the intervening dip.

The maximum high frequency which can produce good definition in the pictures is proportional to distance f on the curve of Fig. 6-9. This assumes that there is no effective reproduction of frequencies beyond the point where the curve is 50% down on the low-frequency side or the sound side.

There are several instrument combinations which may be used for video i-f alignment. For only the peaking of the responses from individual stages, where the response of each stage has but one peak, we may use a marker type (single-frequency) signal generator and an electronic voltmeter as at the upper left in Fig. 6-10. The same class of work may be done by using the marker generator with modulation for the input signal, and for the output indicator using an oscilloscope, as at the upper right.

When it comes to observing the overall response of the entire i-f amplifier it would be possible to check relative gains at various points along the response by making a number of measurements with either of the combinations just mentioned. This is a rather laborious method, and none too accurate. It is far better to check all overall responses with the instruments shown at the bottom of Fig. 6-10; the marker generator used to identify various frequency points, the sweep generator to cover the overall band width, and the oscilloscope to show the entire response at one time.

The marker type generator always is used without modulation when employed only to identify frequency points on the sweep range. Usually this generator is used unmodulated also when the

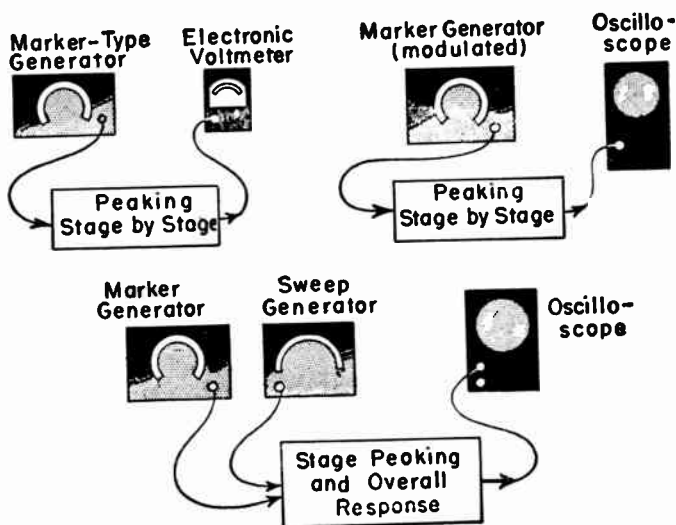

Fig. 6-10.—Instrument combinations used for alignment of video-sound i-f stages.

output indicator is an electronic voltmeter. When the output indicator is an oscilloscope the marker type generator is used with audio modulation and the internal sweep of the scope is synchronized to the modulation frequency.

When aligning the interstage couplers it is important to keep the output of the sweep generator or of the marker type generator used without a sweep at the lowest value which will give useful

readings on the output indicator. If a further increase of output changes the *shape* of the response curve or the waveform of the curve (other than making it higher), one or more of the stages are being overloaded by excess generator output and the response is being distorted.

When the marker generator is used to supply marker pips on the response curve the output of this generator must be kept as low as allows positive identification of frequencies. Otherwise the curve will be thrown out of shape by the excessively strong marker signal. Marker pips naturally are clear and distinct along the upper parts of the response where there is high gain in the amplifier, but they become progressively weaker as they run down the slopes at either side.

Always use the lowest or most sensitive scale of the electronic voltmeter. If the reading tends to go off scale, reduce the output of the generator rather than changing to a higher scale. Always use maximum gain in the vertical amplifier of the oscilloscope. If the curve becomes too high, reduce the generator output rather than the gain or sensitivity of the scope.

When the electronic voltmeter is connected to the video detector load resistor, where the signal is a varying direct voltage, the meter may be used as a d-c instrument. When used ahead of the video detector or when used on the output of a video amplifier tube the electronic voltmeter should be used with a high-frequency probe. When the oscilloscope is connected to the video detector load it may be used with the filter probe described earlier. When the scope is used ahead of the video detector or on the output of

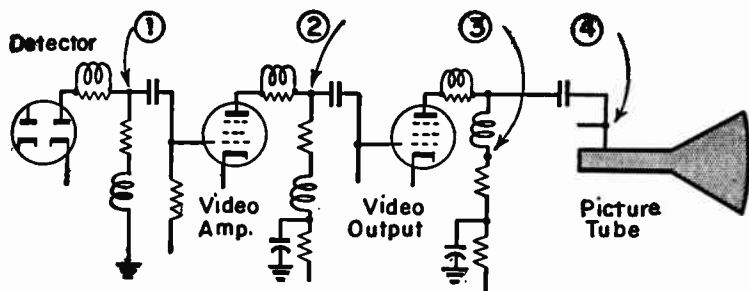

Fig. 6-11.—Points at which the electronic voltmeter or oscilloscope may be connected for output measurements.

a video amplifier it must be fitted with the detector probe to demodulate the signals which are at high frequencies.

Either the oscilloscope or the electronic voltmeter used as an output indicator may be connected to any of the points shown by Fig. 6-11. The same signal exists at all these places. The signal is weakest at the detector load resistor, point 1. It is stronger at the load resistor of the first video amplifier, point 2, and still stronger at the load resistor of the video output tube, point 3, and at the input to the picture tube, point 4. In the last part of its travel the signal may be delivered from either the plate or cathode of the video output amplifier and may go to either the grid or cathode of the picture tube, all depending on the circuit design.

When employing the lowest scale of an electronic voltmeter there usually is enough sensitivity to give clear readings with the meter at the detector load resistor. If the oscilloscope lacks sensitivity it may be connected to any of the points farther along toward the picture tube, or at the picture tube.

During alignment anywhere in the video i-f amplifier the input from the signal generator or generators often is fed into the control grid of the mixer tube. It is undesirable to have the high-frequency voltage from the r-f oscillator reach the mixer grid at the same time. The r-f oscillator may be put out of action by connecting a capacitor of about 0.001 mfd from the oscillator grid to chassis ground. If the r-f oscillator is not on a series heater string the tube may be removed from its socket during video i-f alignment.

If there is automatic gain control on any of the i-f tubes this control should be overridden with a battery bias as explained in earlier pages. The contrast control should be set in its usual operating position. This control may have to be set lower should oscillation occur in the amplifier tubes during adjustment. The channel selector should be set at a channel in which there is no local transmission, and the antenna or transmission line disconnected from the receiver.

Using a metal tipped screwdriver or wrench for adjustment of the coil slugs during alignment may cause no trouble in some cases. It is safer to employ an alignment tool made entirely of hard fibre or plastic.

There are three generally used methods of connecting the test

instruments during alignment of stages in the video i-f amplifier. The first general method is shown in principle by Fig. 6-12. The electronic voltmeter or oscilloscope used as the output indicator is connected to any signal point following the video detector tube, which means any point shown by Fig. 6-11, and is allowed to remain connected at the same chosen point throughout the process of alignment. The output of the marker type generator, or of the sweep and marker generators together, is coupled to the control grid of the i-f amplifier immediately ahead of the video detector as at *a*. Then the coupler *A*, between i-f tube and detector, is aligned for the desired response as affected by this one coupler.

The next step is to remove the generator coupling from point *a* and apply it to point *b*. Now coupler *B* is aligned to obtain the response desired from the two stages preceding the detector. In

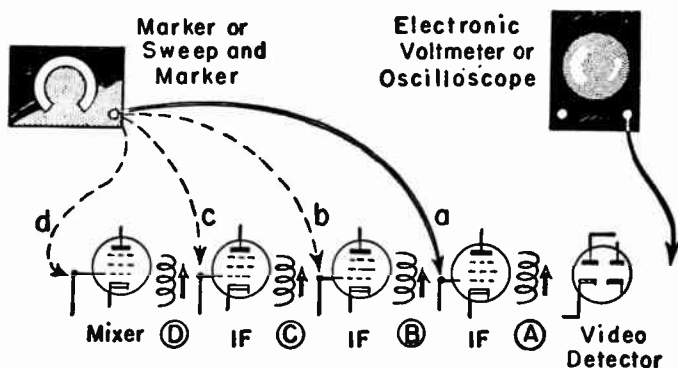

Fig. 6-12.—Connection from the generators may be moved back from grid to grid during alignment of successive stages.

following steps the generator input is coupled to point *c* and finally to point *d*, which is the mixer control grid, while couplers *C* and *D* are aligned with their respectively lettered generator couplings in place. With this method the first step gives the response of coupler *A* alone. The next step gives the combined response from couplers *A* and *B*, the third step shows the combined effect of couplers *A*, *B* and *C*, and finally we have the overall response of the entire video i-f amplifier when the generators are connected to the mixer control grid.

Fig. 6-12 illustrates also the second general method of align-

ment. The only difference between this and the first method is that now the generator or generators are coupled to the control grid of the mixer and left there during adjustments in all stages. The output indicator, voltmeter or scope, is connected as before and is not changed during the alignment process.

With either of the two methods mentioned, the signal strength or voltage at the output indicator will become greater and greater as successive stages are brought into correct alignment. The generator output must be continually reduced as the work proceeds. It is a good idea to drop the output to zero between stages, then bring the output up just enough to obtain a readable response on the meter or scope when ready to align a following stage.

The third general method of alignment is shown in principle by Fig. 6-13. Here we observe the response of each stage independently of all other stages. For a first step the output indicator may be connected to the video detector load resistor, as at *a*, and the output of the generator or generators coupled to the control grid of the last i-f amplifier, as with the lead marked *a*. Now we align coupler *A* for the desired stage response.

For the next step the connection of the output indicator is moved back to the plate of the last i-f amplifier, connection *b*, with a detector probe in series with the lead. At the same time

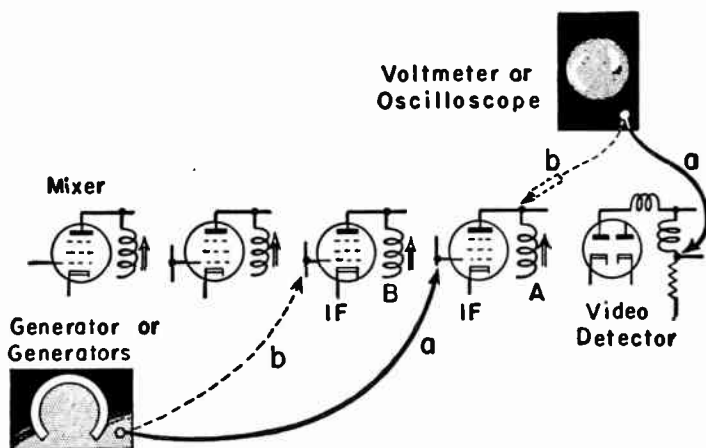

Fig. 6-13.—Instrument connections for observing the response and making alignment adjustments in individual stages.

the generator or generators are coupled to the control grid of the i-f amplifier next farther back toward the mixer. Now we align coupler *B* for the response desired from this coupler individually. In following steps the generator or generators and the output indicator are moved together to include between their connections each additional coupler. The final alignment will be with the generator or generators to the control grid of the mixer and with the output indicator to the plate of the i-f amplifier which follows the mixer.

When traps are associated with any of the interstage coupling coils or transformers, every adjustment of the trap will somewhat affect the response of the coupler to which the trap is inductively or capacitively coupled. Also, every adjustment of the coupling coil or transformer will affect the trap frequency to some extent. If all the traps have been adjusted before the couplers are aligned it will be necessary to go back over the traps and make any slight changes which are needed to bring them back to the correct frequency.

Regardless of whether there are traps in the i-f amplifier section, you should make it an invariable rule to make a recheck of all adjustments after going through them the first time. When

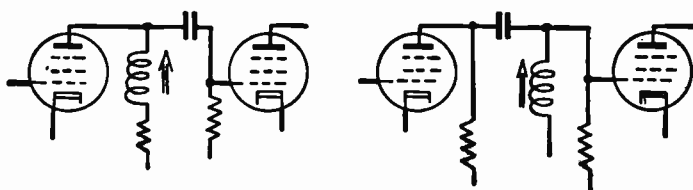

Fig. 6-14.—Couplings of this general type give a single-peaked response for each stage.

the alignment has been made for all stages, repeat the whole process and do whatever touching up is required.

Interstage Couplings.—The type of coupling used between mixer and i-f amplifier, between amplifiers, and between amplifier and video detector, determines the method of alignment which is most suitable. Impedance couplings with single tuned coils are shown by Fig. 6-14. The tuned coil may be in the plate circuit of the first tube, as at the left, or in the control grid circuit of the

second tube, as at the right. Both couplings provide a single-peaked response from their stage when considered by itself. The single-peaked responses combine to form the desired overall response. So far as alignment is concerned, the two couplings shown here are handled in the same way.

At the left in Fig. 6-15 is a transformer coupling with individually tuned primary and secondary windings. The transformer will provide a single-peaked response when there is loose inductive coupling between windings and when both windings are tuned to the same frequency. When the coupling between windings is made closer or tighter the response will have two peaks. With both windings tuned to the same frequency one of the peaks

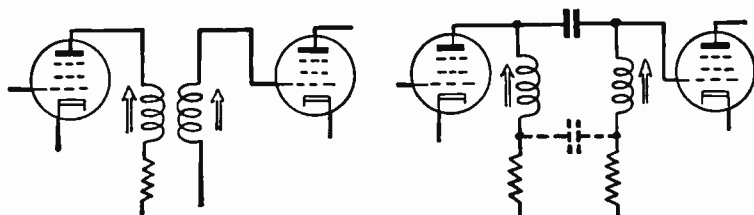

Fig. 6-15.—Couplings of these types usually give a double-peaked response, but may provide a single peak.

will be higher than this frequency and the other will be lower. The tighter the coupling the farther apart the peaks will be separated in their frequencies.

At the right in Fig. 6-15 is a double impedance coupling with one tuned coil in the plate circuit of the first tube and another tuned coil in the grid circuit of the second tube. There is no intentional inductive coupling between the two coils. There is either top coupling as shown by the capacitor and its connections in full lines or else bottom coupling as shown in broken lines. The two coils may be tuned to the same frequency for single-peaked response or to different frequencies for a double peak. Increase of capacitance in the coupling changes the resonant frequency of both coils.

The diagrams of Figs. 6-14 and 6-15 show four basic types of interstage couplers. Any of them may be modified in various details to secure certain operating characteristics desired by designers of receivers. Ordinarily these modifications do not affect the alignment methods to be explained.

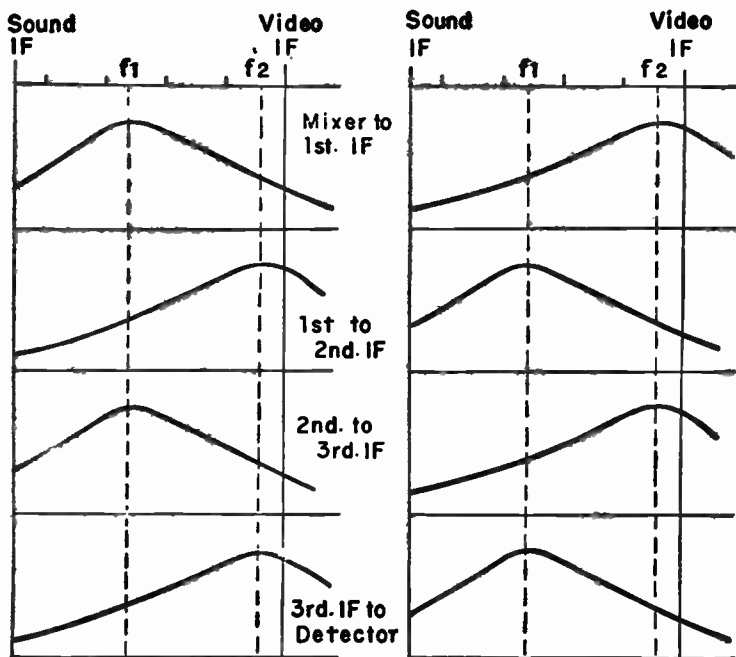

Fig. 6-16.—Typical peaking for each of four couplers tuned alternately to two frequencies.

Alignment of Single-peaked Impedance Couplers.—Most receivers have either three or four i-f amplifier tubes. With three such amplifiers there are four tuned couplers; one from mixer to first amplifier, two between the two i-f amplifiers, and one between the last amplifier and the video detector. With four i-f tubes there must be one additional coupling, making five in all.

The frequency to which each coupling should be tuned is specified in service literature or on circuit diagrams issued by the manufacturer. The frequencies for all the couplers nearly always are in between the sound intermediate and video intermediate frequencies of the particular receiver. But there is no such thing as a standard set of coupler frequencies in relation to the intermediates or in relation to anything else.

Receivers having four i-f couplings and using intercarrier sound systems usually peak all four couplers to only two frequencies as indicated in a general way by Fig. 6-16. Frequency

f_1 is somewhere around 2.6 mc below the video intermediate frequency used in the receiver. Frequency f_2 is somewhere near 0.4 mc below the video intermediate. Adjacent couplers never are tuned to the same frequency for this almost surely would cause regeneration and oscillation in the amplifier.

The left-hand set of curves show the first and third couplers tuned to the lower frequency f_1 , and the second and fourth couplers tuned to the higher frequency f_2 . The right-hand set of curves show the first and third couplers tuned to the higher frequency, with the second and fourth couplers tuned to the lower frequency. Both methods are used, it depends on the make and model of receiver. We aim for the same shape of overall frequency response no matter which order of tuning is employed.

With five interstage couplers the usual practice is to tune them to five different frequencies which lie somewhere between the video and sound intermediate frequencies of the receiver. Combinations of frequencies may be on the order of those shown by Fig. 6-17. Quite often there will be two frequencies up near the video intermediate, within less than one megacycle of this intermediate. Then there will be two more frequencies down near the sound intermediate, usually within one megacycle of this intermediate. Finally, there will be one frequency near the middle of the range between the two intermediates, but somewhat closer to the video than the sound intermediate.

The high and low coupling frequencies often alternate, as in the left-hand set of graphs, with the middle frequency used for the last coupler or for the coupler just ahead of the video detector. In other cases the successive frequencies may increase through two or more successive couplings, as in the right-hand set of graphs. Fig. 6-17 illustrates only some possible orders of tuned frequencies; there are many others in use. Two adjacent couplers never are tuned to the same frequency, the difference being anything from 0.5 to 1.0 mc.

Alignment of the several couplers in a stagger tuned single-peaked i-f amplifier is conveniently carried out with the use of a single-frequency marker type generator, without any sweep generator, to provide the input signal, and with an electronic voltmeter as an output indicator. The steps are as follows:

1. Couple the output of the signal generator very loosely to

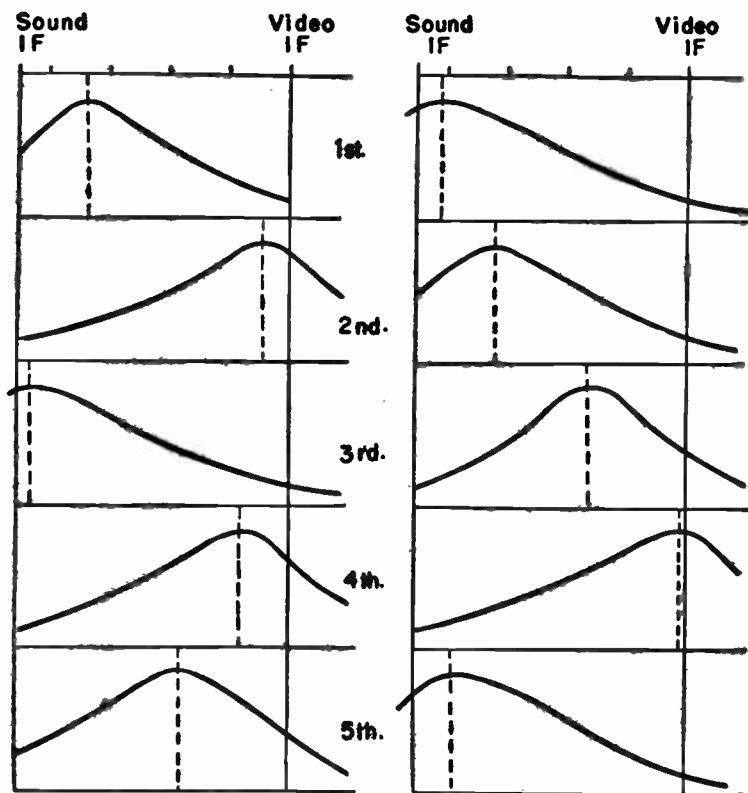

Fig. 6-17.—Peaking for each of five couplers tuned to five different frequencies.

the control grid of the mixer tube or to any point in the grid circuit which is not at ground potential. Use the generator unmodulated.

2. Connect the electronic voltmeter to the high side of the video detector load resistor or to the load resistor of a video amplifier tube as previously explained.

3. Turn on the power for the receiver and meter and let the two of them warm up. Make certain that all ground connections are in place and tight.

4. Tune the generator back and forth through the range of video intermediate frequencies to note rise and fall of the meter pointer. Adjust the generator output so that the highest reading

brings the meter pointer about half way up on the lowest voltage scale. Check the settings of the receiver contrast control, the channel selector, see that the antenna is disconnected, that the r-f oscillator is removed or shorted, and that everything is ready for testing.

5. Tune the generator to the precise frequency at which any one of the couplers is to be aligned. Then adjust that coupler for maximum reading on the meter. This may be higher or lower than the peak reading obtained during the preliminary checkup. If the meter pointer tends to go off scale, reduce the output of the signal generator. If there are two couplers which should resonate at the same frequency, align both of them with the one setting of the generator.

6. Retune the generator to the frequency for another coupler or couplers and align these others for maximum reading on the meter. Proceed thus until all couplers have been aligned at their particular frequencies for maximum meter readings.

This operation may be performed also with the oscilloscope instead of the electronic voltmeter as the output indicator. Use the single-frequency marker type generator, but have its output modulated at an audio frequency. Couple the generator to the mixer control grid and the oscilloscope to the load resistor of the video detector or a video amplifier. Adjust the internal sweep of the scope to the modulation frequency of the generator.

Remaining steps are similar to those when employing the electronic voltmeter. With the generator tuned accurately to the frequency at which each coupler should resonate, align that coupler for maximum height of trace on the scope. Do this for each coupler. When all couplers have been aligned in this manner the over-all response should be observed by using the sweep and marker generators with the oscilloscope.

Single-peaked impedance couplers sometimes are aligned by the method shown in Fig. 6-12 with the sweep and marker generators moved back stage by stage from *a* on the control grid of the last i-f amplifier to *d* on the control grid of the mixer.

When using this stage-by-stage method it is necessary to have a set of response curves applying to the particular receiver. Fig. 6-18 shows a set of curves such as might apply to one particular make and model of receiver. At the beginning of the alignment

process, with only one coupler between the generators and scope, the response will show a single peak. With two couplers included, as the generators are moved back, there will be two peaks. With three couplers included there still will be only two peaks, but they will be more nearly in balance. The over-all response, with all couplers between the generators and scope, should be that desired for the video i-f amplifier as a whole. The greater the number of couplers which contribute to the shaping of the response the steeper will be the sides or slopes of the curve.

Alignment of Double-peaked Couplers.—Although the transformer coupling and the double-impedance coupling of Fig. 6-15

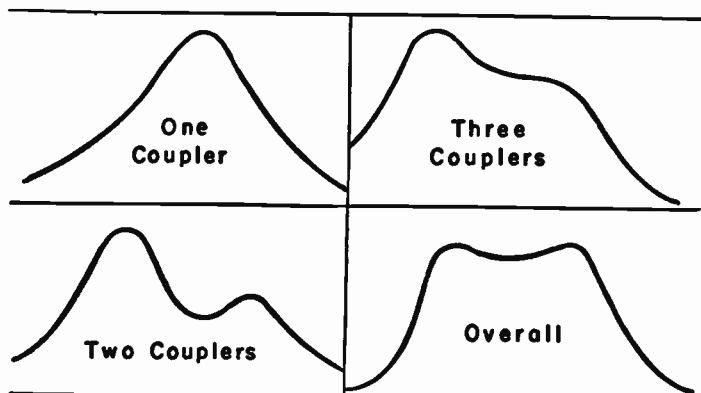

Fig. 6-16.—Typical responses when aligning to include one additional coupler at each successive step.

may be so loosely coupled as to have a single-peaked response there would be no particular object in using them thus, for such a response may be had from a single tuned coil. Consequently, nearly all these double-tuned couplers have a double-peaked response for each stage as well as for any number of successive stages working together.

The transformer with tuned primary and secondary, and the double-impedance coupling with two tuned coils capacitively coupled act similarly, produce responses of similar shape, and are aligned in the same manner. Therefore, for the sake of simplicity, we shall hereafter refer to both as transformer couplings and speak of the coil or winding in a plate circuit as the plate coil and of the one in a control grid circuit as a grid coil.

Sometimes the coupling is adjustable, either by means of a movable core inside both windings or else by means of a variable coupling capacitor between the coils. When both coils are separately tuned to the same frequency and the coupling is made very loose, there will be a rather sharp single-peaked response as shown at the left in Fig. 6-19. As the coupling is made closer the response will show two peaks, as in the center diagram, with the

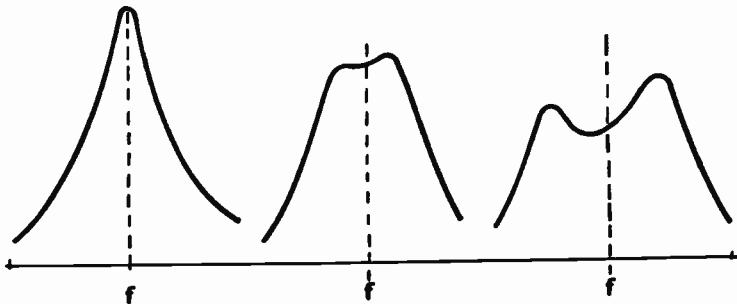

Fig. 6-19.—As the coupling is made closer, the response will change as shown from left to right.

frequency of one peak below the tuned frequency and that of the other peak above the tuned frequency. As the coupling is made still closer or tighter the two peaks will move farther apart, as at the right, and the dip or valley between the peaks will become deeper. All this shifting of the peaks is brought about by varying the coupling.

If the coupling is not adjustable it may be of any degree of looseness or tightness, depending on the construction of the transformer. With the two coils individually tuned to the same frequency, the transformer then may deliver any of the responses shown by Fig. 6-19, or any other response desired by the designer.

If the coupling is fixed and the two coils are tuned to different frequencies the tuning of each coil will affect or shift the peak whose frequency is nearest the frequency to which that coil is tuned. Although the peak corresponding to coil frequency will be the one chiefly affected, every adjustment of either coil will affect also the other peak to some extent.

When the two coils are to be tuned to the same frequency, and the coupling is fixed, put one of them out of action while the other

is tuned, then make the second one non-resonant while the first is tuned. One coil may be made inoperative by connecting across it a fixed resistor of about 500 ohms or else a fixed capacitor of about 0.001 mfd. Either coil might be individually tuned also by turning the slug of the other one all the way out during the process, but with the first coil correctly tuned it would affect the resonance curve of the second one when you attempt to tune the second coil to the same frequency.

If the coupling is adjustable to the extent that it may be made very loose, it then is possible to tune each coil to the same frequency with no appreciable effect from the other coil. Later the coupling may be tightened to separate the two peaks of the final response.

For correct alignment when the response of all stages, or even one of them, is double-peaked it is necessary to use the sweep and marker generators for the input, and the oscilloscope for output indicator. Adjust the center frequency of the sweep generator to approximately midway between the sound and video intermediate frequencies of the receiver. It will be necessary to have a sweep width of at least 6 mc, and 8 to 10 mc usually proves more satisfactory.

The marker generator is used without modulation. During the process of alignment this generator will be tuned to the video and sound intermediate frequencies, also to frequencies at which there should be peaks in the several responses, to frequencies at which the downward slopes should commence, and quite possibly to the interference frequencies for which traps are provided.

The oscilloscope is connected to the video detector load resistor, to the load of a video amplifier tube, or to the input (grid or cathode) of the picture tube. The choice between these connections depends on how sensitive is the vertical amplifier of the scope. The less its sensitivity, the farther toward the picture tube the connection must be made to secure traces of satisfactory height.

There is a decided possibility that the response will be distorted by resonance in the primary winding when the generators are coupled to the following control grid and the secondary. To avoid this possibility it is well to short the primary as shown by Fig. 6-20. A resistor of about 500 ohms or a capacitor of about 0.001 mfd capacitance should be clipped across the primary,

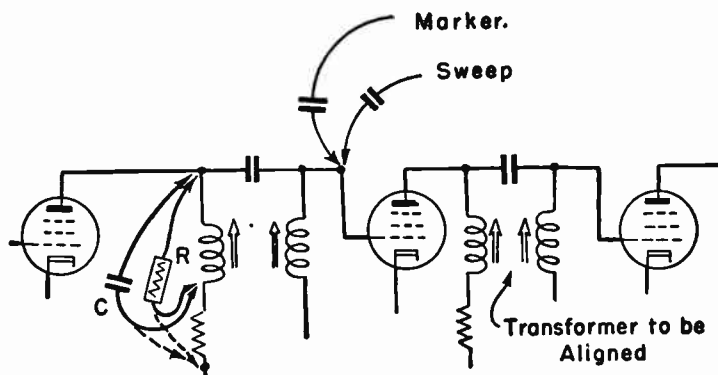

Fig. 6-20.—Shunting of transformer primaries to prevent their affecting the response.

whether this winding is a separate coil or is part of a transformer. This shorting or shunting unit should be kept on the plate coil which precedes the transformer being aligned. If the generator couplings are moved back toward the mixer during successive steps of alignment, the shorting connection should be moved back with the generators at each step.

Alignment may be made by successively including more and more stages, as shown in steps *a*, *b*, *c* and *d* of Fig. 6-12. Then the last step will give the overall response. Another way is to align each stage by itself, as shown in principle by Fig. 6-13. When all stages have been thus aligned it is necessary to observe the overall response with the generator inputs at the mixer grid and the scope at the video detector load or beyond.

When using the first method, of successively including more and more stages, it is practically imperative that you have available a set of response curves applying to all the steps as they should be carried out with the particular receiver being handled. With the stage by stage method the receiver curves are almost as necessary, but there is some chance of making a satisfactory alignment without them.

A set of alignment responses for the first method might appear like those of Fig. 6-21. For curve *A* you have only one transformer affecting the response, with the generators at the grid of the third (or last) i-f tube, and the scope at the detector or beyond. The primary and secondary slugs or trimmers are adjusted to

obtain this desired response. Then the generators are moved back one stage. Adjustment now is made of the primary and secondary of the additional coupler thus included until obtaining the response shown at *B*. Adjustments of the transformer first aligned should not be altered to obtain this second response.

The next step is to move the generators back one more stage and to adjust the primary and secondary slugs or trimmers of the added coupler in obtaining the response shown at *C*. This should be done without disturbing the adjustments of either transformer previously aligned. Any additional stages are treated

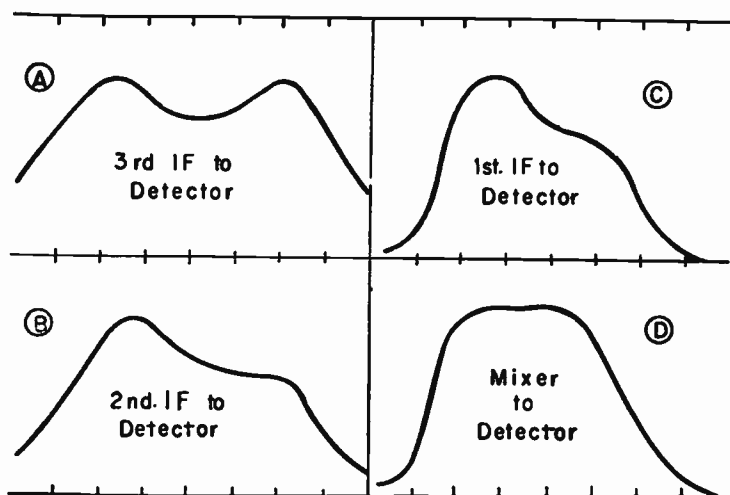

Fig. 6-21.—Successive responses when commencing with one coupler and including one more in each following step.

in the same way. The final step places the generators at the mixer grid. Then the last transformer which has been included is adjusted to obtain the overall response shown at *D*.

Alignment of Individual Stages.—When we wish to observe the response of a single stage and carry out the alignment process on each stage all by itself, the generator and oscilloscope connections usually are made as shown by Fig. 6-13. The sweep and marker generators are coupled to the control grid of the tube preceding the transformer to be aligned. If the aligned transformer immediately precedes the video detector, the oscilloscope

is connected to the detector load resistor. The scope vertical input should be fitted with a filter probe to remove high video frequencies, but need not be fitted with a detector probe. The detector probe may be used if desired; the only effect being to lessen the height of the trace.

If the aligned transformer is farther ahead or farther toward the mixer, the vertical input lead of the scope must be fitted with a detector probe. The probe then is connected to the plate of the tube following the aligned transformer. It is not necessary to disconnect the B+ lead from the plate circuit.

Note that neither the generators nor the oscilloscope are directly coupled or connected to the plate or grid circuits of the transformer being aligned. All instruments are separated from these circuits by a tube. Were connection made to the plate circuit or the grid circuit of the transformer being aligned, the capacitances of the leads and the instruments would completely upset the tuning and the response. As a precautionary measure it usually is advisable to employ the resistor or capacitor shunt in the manner shown by Fig. 6-20.

When the test instruments have been correctly coupled and connected, and all other preliminary settings have been made in the usual manner for alignment work, the primary and secondary of the transformer are adjusted to give the response which is correct for the stage being worked on. Quite often all the transformers are of similar design and have the same degree of coupling. Then the responses of all stages may have the general form shown at *A* in Fig. 6-22. If there is a trap directly associated with the aligned transformer the response will show the effect of that one trap. At *B* is shown how the first curve might be altered by a trap for accompanying sound. Traps for other interference frequencies would place dips in the response at those frequencies.

The response of a single double-peaked transformer is not always symmetrical with respect to frequency, as it is at *A*. Quite often the degree of coupling designed into a certain stage will produce a response such as shown at *C*. Again the coupling in a particular transformer may be loose enough to cause only a single broad peak, as at *D*. The combined effect of all stages, both symmetrical and non-symmetrical, is intended to be the typical overall response with which we have become familiar.

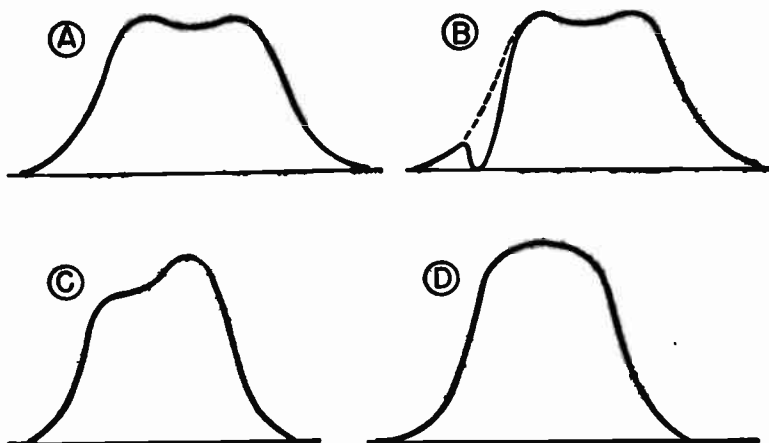

Fig. 6-22.—Typical responses of individual couplers of the transformer or double impedance types.

On the overall response the video intermediate frequency will be about half way down the high-frequency slope, and the sound intermediate frequency will be far down on the low-frequency slope. But on the response for any single stage these two frequencies usually will be well up on the slopes, or may be on the peaks. The reason is that when a signal goes through a number of stages in cascade the response becomes narrower and narrower, the slopes are drawn in toward the center. Consequently, the video and sound intermediate frequencies which may be at or near the peaks of individual stage responses will be well down on the slopes of the overall response. If you push these frequencies down the slopes of each stage, they probably will disappear in the overall curve.

Overall Response.—Regardless of the kind of couplings in the video i-f amplifier and of the methods used for adjustment of each coupling, the alignment must conclude with a check on the overall response with the generators at the mixer control grid and the oscilloscope at the video detector load or beyond. With the sweep covering the entire frequency range of the amplifier, use the marker generator to determine that the video intermediate frequency is 30 to 50 per cent down with reference to the peak response. Set the marker also to the frequencies of all traps used

in the amplifier to make sure these frequencies are well attenuated.

If the overall response is not of the desired shape it will be necessary to slightly readjust the various stages. Before altering the settings of any slugs or trimmers make a sketch showing the original positions of the nuts or screw slots. Then make note of whether you are going to turn an adjustment clockwise or counter-clockwise. Change only one adjustment at a time, and give it no more than one-tenth turn before examining the result. It is very easy to get everything so far out of line that the whole alignment job has to be repeated.

Adjustment of each coupler will have maximum effect at the frequency to which that coupler was tuned, but every adjustment

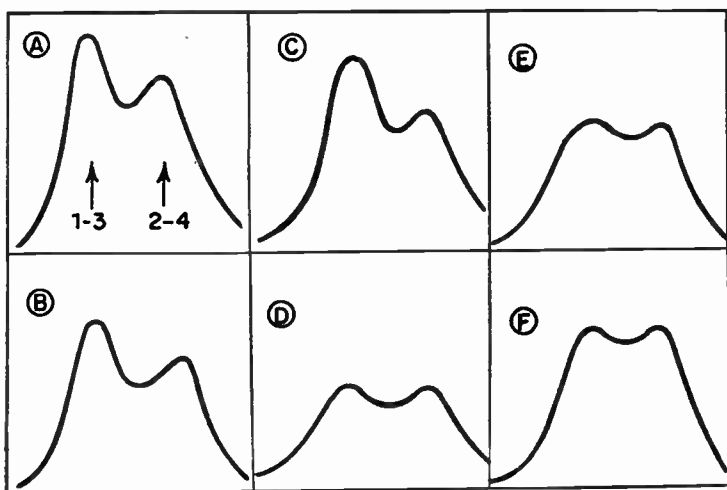

Fig. 6-23.—How the overall response may change during slight readjustment of couplers in different stages.

will affect the entire response curve—sometimes to an astonishing extent.

Fig. 6-23 shows what may happen during adjustment on an i-f amplifier having four tuned couplers, with numbers 1 and 3 originally tuned to the frequency indicated by one of the arrows in diagram A, with numbers 2 and 4 tuned to the frequency indicated by the other arrow.

For the first adjustment, coil 2 was tuned to a higher frequency. The result on the overall response is shown at *B*. For the second adjustment, coil 1 was tuned to a higher frequency, with the overall result shown at *C*. Then coil 3 was tuned to a lower frequency, with the result shown at *D*. So far, the total result had been to get rid of the extreme inequality between the peaks and to lessen the percentage by which the response drops between peaks.

For the next adjustment, coil 2 was tuned to a lower frequency. This brought number 2 back to the frequency from which it started in response *A*. The result is shown at *E*; the response is moved slightly lower in frequency and there is a considerable improvement in overall gain. For a final adjustment, coils 1 and 3 were both changed to a slightly higher frequency. This moved both peaks a very little to the right, but brought up the overall gain and left an entirely acceptable dip between the two peaks of the response. It is changes such as these which you may expect to see during any final touchup of the overall response curve.

Alignment for Intercarrier Sound.—In the overall responses for all video i-f amplifiers the video intermediate frequency must be brought to a point which is no less than 50 per cent and no more than 65 to 70 per cent up on the high-frequency slope. When the sound system operates at the sound intermediate frequency this sound intermediate frequency should be well down on the low-frequency slope, but its position is not too critical. Usually this accompanying sound frequency is attenuated by one or more traps tuned for the purpose.

But when the receiver uses intercarrier sound the position of the sound intermediate frequency on the overall response is as critical or even more so than the position of the video intermediate. In a few receivers this sound intermediate may be allowed as high as 8 to 10 per cent of the peak response, but nearly always it may be no higher than 5 per cent and may give best results when down around 3 per cent of the peak.

Fig. 6-24 shows overall responses for video i-f amplifiers where there is intercarrier sound. In the upper response the sound intermediate is kept down on the relatively flat extension at the low-frequency end of the curve. This is accomplished by correct design and careful alignment of the interstage couplers.

In the lower response the sound intermediate frequency is on a

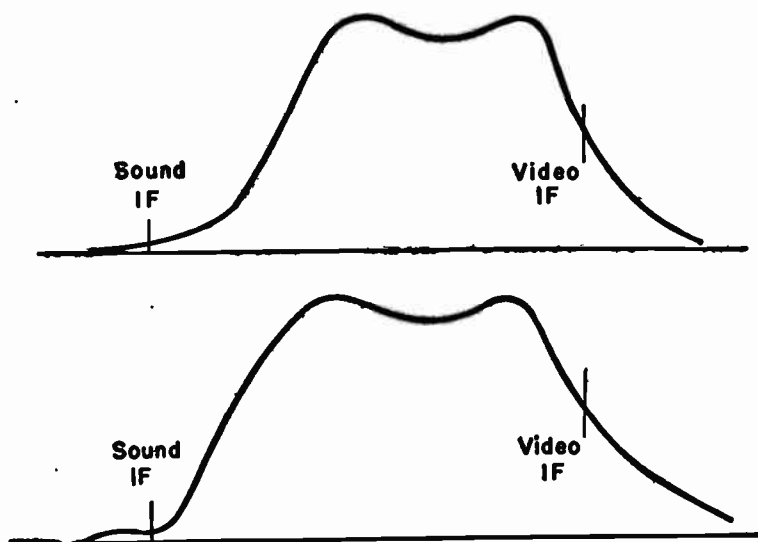

Fig. 6-24.—Overall responses of video-sound i-f amplifiers used with intercarrier sound systems.

shelf or a “plateau” formed on the low-frequency end of the response. This shelf is formed by a rather broadly tuned trap placed somewhere in the video i-f amplifier. This intermediate sound trap is tuned to leave a response of a few per cent, with the sound intermediate frequency just far enough down to come on the nearly flat part of the response. The particular response shown here is redrawn from Stewart-Warner service literature, they being one of the manufacturers using this method of shaping the response.

If the sound intermediate frequency gets up onto the more steeply sloped part of the response the sound signal will acquire so much amplitude modulation, in addition to its frequency modulation, that the effect cannot be overcome by the sound demodulator. The result is a disagreeable buzz, not a hum, which cannot be entirely removed by any adjustment in the sound system. Amplitude modulation results because frequency deviations toward higher frequency run the sound signal up on the response curve, which really is a curve of gain, and deviations toward lower frequency carry the signal down, where there is less gain. Thus

the amplitude is increased during upward deviations and is decreased during downward deviations. The stronger the sound signal the worse the effect, because with f-m sound the extent of deviation corresponds to sound volume.

Regeneration.—In any overall response it is desirable to have maximum gain with a curve of correct shape. In making touchup adjustments to increase the gain or to lessen the amount of dip between peaks it is possible to make the frequencies of adjacent coils too near alike. Then there may be feedback from plate to grid of the tube between these coils, and regeneration will occur. An increase of signal input, an increase of contrast control, or almost any other change may allow uncontrollable oscillation. The response will go off the screen of the oscilloscope. If the picture tube is connected, its screen will become very bright.

Oscillation will continue with the generator output reduced to zero, or disconnected, and with the contrast control turned back to zero. It can be stopped only by turning off the power to the receiver or amplifier. If a receiver comes to you so far out of adjustment as to oscillate, the regeneration must be stopped in order to carry out realignment. It may be possible to commence the work with the contrast control turned well down and with very small output from the sweep generator. You may detune any or all the coils, except the first one to be aligned, by giving their slugs or trimmers a turn or two. Another method consists of connecting capacitors of about 0.001 mfd from control grids to ground in all stages except the one to be aligned first. This first stage should be the one nearest the video detector. Then take off the capacitors, one by one, as you work back toward the mixer.

Regeneration which does not break over into oscillation will cause irregular peaks in the response. Such trouble will result from using generator or scope leads which are not shielded or with which the shields are not well grounded, and sometimes from using a scope lead without a filter to remove high frequencies. Even with leads shielded, grounded, and correctly filtered, regeneration may be caused by excessive output from the sweep generator. If reducing this output changes the shape of the response, other than its height, the output must be kept down during alignment.

Feedback and regeneration may result from incorrect place-

142 APPLIED PRACTICAL RADIO-TELEVISION

ment of parts or wiring connections in the amplifier. Leads for plates, control grids, and screens which originally were well spaced may have been moved together or moved too close to chassis metal. Another possible cause is a defective bypass capacitor on the voltage dropping resistor in a plate or screen circuit.

Chapter 7

ALIGNMENT OF SOUND SECTION

So far as alignment is concerned we must consider two general types of sound sections. The first type is shown in simplified form by Fig. 7-1. Here the sound takeoff is either at the output from the mixer tube, which is in the tuner section, or is at the output of some following sound-video i-f stage. The modulated intermediate frequency delivered to the sound section is the sound intermediate frequency secured from the mixer and passed

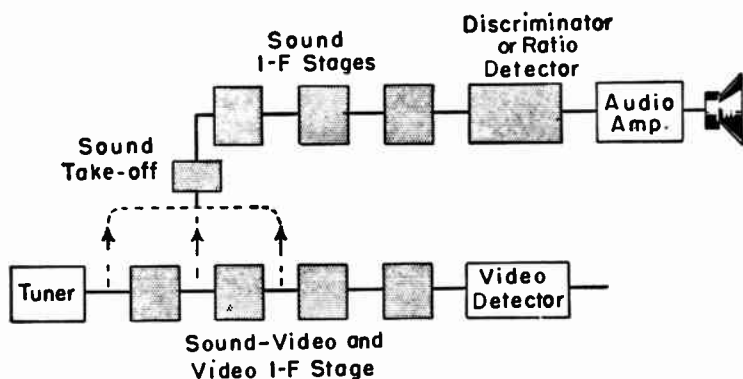

Fig. 7-1.—A sound section operating at the sound intermediate frequency, with takeoff ahead of the video detector.

through the sound-video i-f stages, it is a frequency which usually is somewhere between twenty and thirty-odd megacycles.

In the sound section itself are two or more sound i-f stages operating at the sound intermediate frequency. The demodulator may be either a discriminator or else a ratio detector. With a discriminator in this position the preceding i-f stage usually is operated as a limiter stage to reduce or remove amplitude modulation.

The second general type of sound section is shown by Fig. 7-2. Here we have an intercarrier sound system. The takeoff usually is from the output of a first or second video amplifier, although in

a few cases it is from the output of the video detector. The modulated intermediate frequency delivered to the sound section always is exactly 4.5 mc, regardless of sound intermediate frequency. There is a single sound i-f stage operating at 4.5 mc. In nearly all receivers the sound demodulator is a ratio detector, although a discriminator might be used if the preceding i-f stage limited any amplitude modulation.

The discriminator and the ratio detector deliver outputs of similar kind and form. Both operate with transformers having a tunable primary winding and a tunable center-tapped secondary winding. Alignment of the transformer for either kind of de-

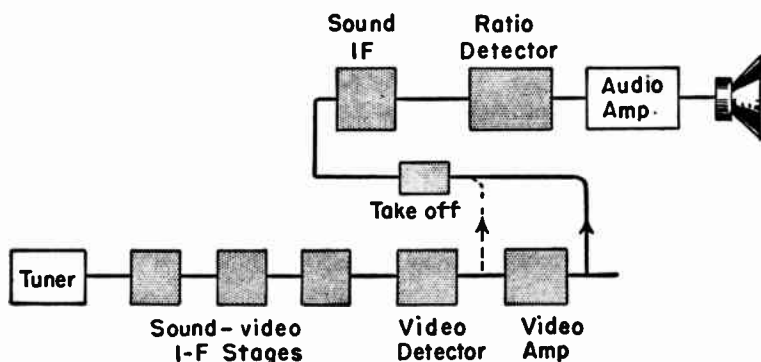

Fig. 7-2.—A sound section of the intercarrier frequency type, with takeoff following the video detector.

modulator is carried out in the same general way so far as output indications are concerned, the chief difference being in the points at which an electronic voltmeter or an oscilloscope is connected to obtain output readings or traces.

The principal parts of a discriminator circuit are shown by Fig. 7-3. Details may vary, but the principles remain unchanged. When the input to this circuit is at constant frequency, with no deviation, the currents in the two diodes are equal. Currents and voltages of resistors R_a and R_b are equal. If we connect a voltmeter from point X to ground the meter will indicate the voltage across R_b , and a connection from X to the top of R_a will allow measuring the voltage across R_a . If the amplitude or strength of the input signal increases, and still there is no change or deviation

If the input signal is at constant frequency, as from the marker generator, and this frequency is the one at which the sound system is supposed to operate, and if there now appears a positive or negative voltage between *Y* and ground, the secondary of the discriminator transformer is out of alignment. Misalignment of the secondary upsets the phase relations in the diode circuits and unbalances the diode currents even when a constant frequency is applied to the system. From all this it follows that we may connect the voltmeter or the scope between point *Y* and ground while aligning the transformer secondary on a signal whose frequency remains constant at the value for which the sound system is designed.

Now we may go to the ratio detector, the principal parts of whose circuit are shown in Fig. 7-4. Again assume that the signal coming through from preceding stages is of constant frequency. Diode currents will be equal, and there will be equal

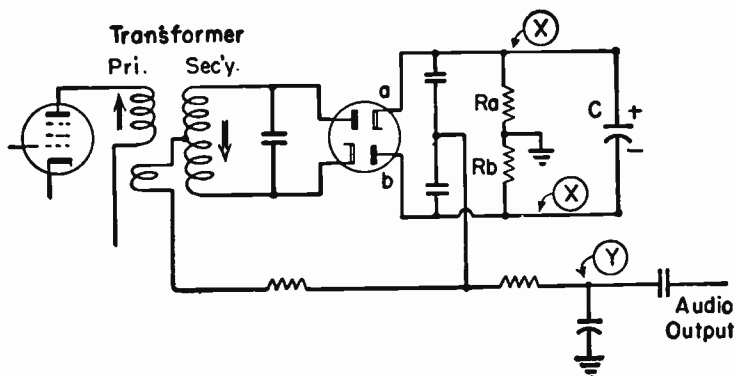

Fig. 7-4.—Ratio detector circuit showing points at which the output is measured.

voltages from any point along the upper line marked *X* to ground and from any point along the lower *X* line to ground. A voltage might be measured between ground and cathode *a*, the top of resistor *R_a*, or the positive side of the large capacitor *C*. A voltage of the same value would be measured between ground and plate *b*, the bottom of resistor *R_b*, or the negative side of capacitor *C*. The two voltages would be equal.

If the strength or amplitude of the incoming signal were to

increase, with the frequency remaining constant, the measured voltages would increase. Were signal amplitude to decrease there would be a corresponding decrease in both the measured voltages. Then we may conclude that a meter or scope may be connected between ground and any point along either line marked *X* to indicate changes of gain during alignment of couplers in preceding stages, and during alignment of the primary of the ratio detector transformer.

Voltage measurements between point *Y* and ground, or across the audio output of the ratio detector, will vary just as do voltages measured across the audio output of the discriminator. The voltage from *Y* to ground will be zero when the incoming signal is of constant frequency, and of the frequency for which the ratio detector is aligned. Frequency modulation at an audio rate will produce between *Y* and ground the regular audio signal which should appear in the output of a ratio detector. But if there is a voltage with a constant-frequency input, of the frequency on which the detector should operate, it means that the transformer secondary is out of alignment. So we shall connect a meter or scope from *Y* to ground while aligning the transformer secondary by means of a signal from the marker type generator. Alignment must produce zero voltage.

Preparing for Alignment.—There are a few preliminary steps to be taken before carrying out the actual adjustments for alignment in sound systems, just as similar steps must be taken before working on the video i-f amplifier.

Connections from the signal generators are made through small capacitors to control grids or other points to be specified. Generator outputs must be kept low enough not to distort the outputs from amplifiers and demodulators. The frequency for intercarrier sound systems always must be precisely 4.5 mc, within 0.0025 mc or within one-quarter of one per cent of absolute accuracy. For other systems the generator is tuned to the sound intermediate frequency, with equal accuracy on a percentage basis.

The electronic voltmeter and oscilloscope are used as d-c instruments when connected to the output of the demodulator. If connected ahead of this point these instruments must be fitted with detector probes. A filter probe or equivalent resistor and

capacitor connections should be in the vertical input lead of the scope even when it is used on the detector output.

Disable or override any automatic gain control which operates on video-sound stages through which the generator signal will pass. Do the same for automatic volume control in the sound section.

The r-f oscillator is not needed except when making a final checkup on actual transmission from stations, so this oscillator may be disabled by grounding its grid through a capacitor or by removing the tube from its socket.

Disconnect the antenna or transmission line. It is a good idea to short the terminals to which the transmission line connects at the receiver. Set the channel selector to a channel in which there is no local transmission, preferably to one of the higher-frequency channels.

Keep in mind that, for television sound, there is frequency deviation of only 25 kilocycles plus and minus for 100 per cent modulation. In f-m sound broadcasting the deviation is 75 kilocycles for 100 per cent modulation.

Interstage Coupler Alignment with Voltmeter.—The following method may be used for alignment of the sound takeoff, if it is

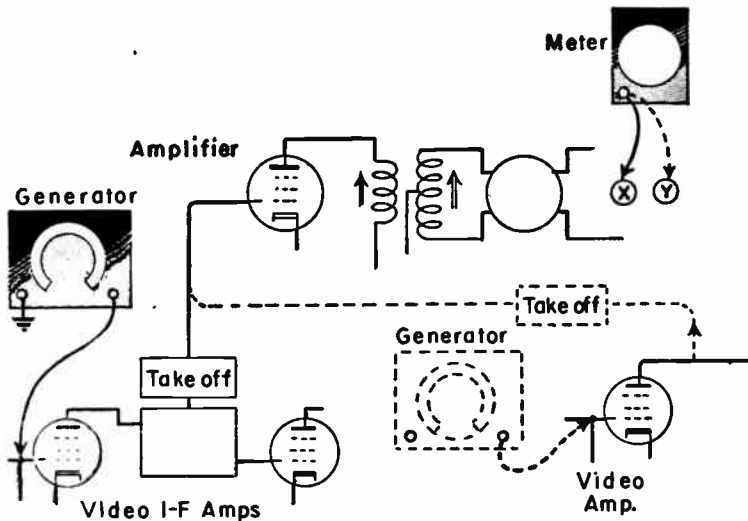

Fig. 7-5.—Generator connections for alignment in sound section.

a tuned type, and for any sound i-f couplers or intercarrier sound couplers which precede the demodulator transformer. Alignment of the demodulator transformer will be taken up a little later. The voltmeter used for the present method may be an electronic type employed as a d-c instrument or it may be a moving coil type whose sensitivity is not less than 20,000 ohms per volt.

1. Use the marker type (constant-frequency) generator without modulation, tuned precisely to the center frequency for the sound system. This is either the sound intermediate frequency of the receiver or else the 4.5 mc intercarrier beat frequency. The generator output may be coupled to the control grid of the amplifier which precedes the sound takeoff, as in Fig. 7-5, or, if the generator already is coupled to the mixer grid for other adjustments it may be left there for alignment of sound stages. If there are several sound i-f stages, and if they are badly out of alignment, the generator coupling may be moved back one stage at a time from demodulator to sound takeoff as the couplers are adjusted one by one.

2. The electronic voltmeter or a high-resistance moving coil meter may be connected to point X as shown in Figs. 7-3 and 7-4 when there is a ground in the demodulator output circuit. With no ground, or with this circuit at high voltage in a ratio detector, connect the meter across the large capacitor marked C in Fig. 7-4. If the tube preceding the demodulator is operated as a limiter the voltmeter may be connected from the limiter control grid to ground, which is a connection across the grid resistor of the limiter tube.

3. Adjust all remaining couplings in the sound system for maximum reading of the meter. This will include everything back to and including the sound takeoff. If there are several sound i-f stages there will be several double-tuned transformers and sometimes single-tuned impedance couplers. With most intercarrier sound systems the only remaining coupling will be the takeoff. Reduce the generator output as alignment proceeds. This is especially important when there is a limiter tube in the sound system, for with a strong signal the limiter flattens the response and makes it impossible to identify a definite peak of voltage.

Demodulator Alignment with Electronic Voltmeter.—For alignment of primary and secondary windings of the discrimina-

tor transformer or ratio detector transformer the connections usually may be arranged as in Fig. 7-6. The steps are as follows:

1. Couple the output of a marker type (constant-frequency) generator to the control grid of the amplifier tube preceding the transformer and demodulator. Use this generator without modulation. Tune it precisely to the frequency used in the sound system, either the sound intermediate frequency or else, for intercarrier sound systems, to a frequency of 4.5 mc.

Instead of coupling the generator to the amplifier just ahead of the demodulator it may be coupled to the control grid of the

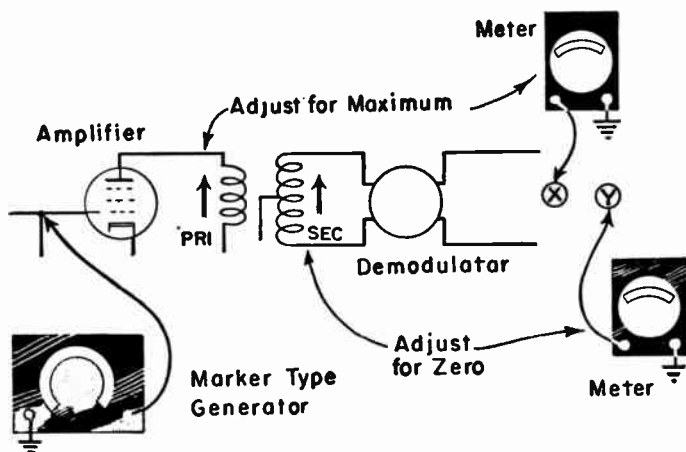

Fig. 7-6.—Connections for generator and output indicator for alignment of demodulator.

tube which precedes the sound takeoff, as shown by Fig. 7-5. For systems employing the sound intermediate frequency this tube will be the mixer or one of the sound-video i-f amplifiers. For intercarrier sound systems this tube will be the first or second video amplifier, whichever precedes the sound takeoff. For the generator connections of Fig. 7-5 to be satisfactory, all the couplers ahead of the demodulator transformer, including any tuned sound takeoff, must be in reasonably good alignment. They must be capable of passing the generator signal.

2. The electronic voltmeter will be connected first to point X and later to point Y in the diagrams. These are the two points similarly lettered in Figs. 7-3 and 7-4 for the discriminator and

the ratio detector. The meter is used as a d-c instrument. Make the first trial with a high-voltage scale, then drop to the lowest or most sensitive scale that will accommodate the measured voltage.

Instead of using the electronic voltmeter, tests may be made with a moving coil type having sensitivity of no less than 20,000 ohms per volt. This meter is connected in the same way as the electronic type.

The voltmeter may be connected between points *X* or *Y* and ground only when there is a ground connection somewhere in the output circuit of the demodulator, substantially as shown in Figs. 7-3 and 7-4. A different connection of the meter is required for some receivers with a ratio detector which operate their entire sound section at potentials 100 or more volts above chassis ground potential. The audio output tube is used as a voltage dropping unit, with a high *B+* voltage on its plate and a lower *B+* voltage at the cathode. Other plates and screens in the sound section then are supplied with their *B+* voltage from the cathode of the output tube. In this case there ordinarily is no ground on the output side of the demodulator. The voltmeter is connected across the large capacitor *C* of Fig. 7-4. For final alignment of the transformer it then is advisable to use the oscilloscope and sweep generator.

3. With the voltmeter between point *X* and ground, or across the capacitor in the special case mentioned in the preceding paragraph, adjust the primary of the demodulator transformer for maximum indication on the meter. Keep the generator output as low as gives a satisfactory meter reading.

4. Set the voltmeter on a high-voltage scale and shift its input connection to point *Y* in the diagrams. If the measured potential is much more than 10 volts no satisfactory test or adjustment can be made with the voltmeter in this position. If the voltage is low set the meter on a lower scale and proceed to adjust the secondary of the demodulator transformer for a zero reading. Now tune the generator back and forth through its correct frequency. You will note that there is a zero reading of the meter at a frequency in between two other frequencies at which the reading is above and below zero. This zero reading, which is between two other readings which are positive and negative,

must be obtained with the generator precisely at the sound intermediate frequency or at the intercarrier beat frequency of 4.5 mc, according to the kind of sound system.

5. Having obtained a zero reading at the correct frequency by adjustment of the transformer secondary it is in order to measure the voltages at frequencies equally above and below the first one. This is most conveniently done if the meter has a zero-center scale or a polarity reversing switch, since the voltage will be negative with the frequency changed in one direction, and positive with the frequency changed in the other direction. Positive and negative voltages should be very nearly equal for equal variations of generator frequency, at least as far as 75 kilocycles below and above the center frequency, and preferably even further. If the voltages are not nearly equal try making a slight readjustment of the demodulator transformer primary to obtain equality. Then check for zero reading at the center frequency for sound, and, if necessary, slightly readjust the transformer secondary.

Alignment with Oscilloscope.—Accurate alignment in the sound system may be made with the oscilloscope as an output indicator, a sweep generator to cover the range of frequency deviation, and a marker generator to identify frequencies on the trace. This combination of instruments is especially useful when aligning the demodulator transformer, but when used for that purpose it might as well be used also for aligning the takeoff coupling and any other sound couplers which precede the demodulator transformer. Because it is necessary that these pre-

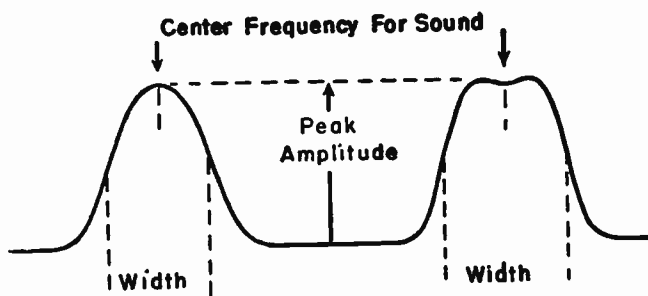

Fig. 7-7.—Overall responses from sound stages preceding the demodulator.

ceding couplers be in alignment before working on the demodulator, we shall consider them first.

The object in aligning the couplers which are ahead of the demodulator is to obtain a single-peaked response which is rather broad, as at the left in Fig. 7-7, or a slightly double-peaked response as at the right. The exact form depends on the design of the couplers; anything between the two responses illustrated will be satisfactory. The center of the response must be at the center frequency for sound, which will be the sound intermediate frequency or the intercarrier beat frequency of 4.5 mc. The band width, measured between points half way down the slopes, should be at least 300 kilocycles or 0.3 megacycle, and may well be more. The peak amplitude should be the greatest possible in combination with correct centering and satisfactory band width. If the response has two peaks, they should be of equal height or amplitude.

The steps in obtaining the overall amplifier response are as follows:

1. Couple the sweep generator to the control grid of the tube which is just ahead of the sound takeoff, as in Fig. 7-5, or to the control grid of the mixer. Set the sweep width to about 1 mc; it

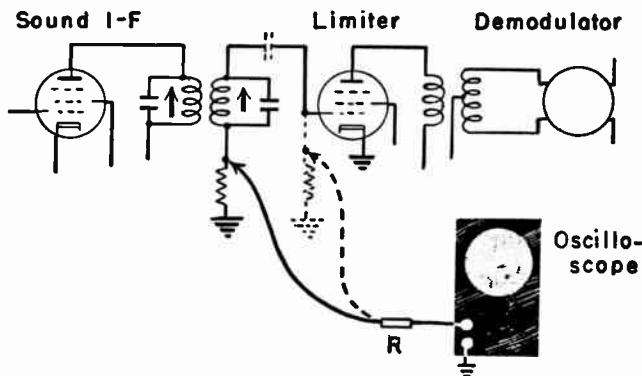

Fig. 7-8.—Oscilloscope connections to limiter grid circuits.

may be adjusted later to suit the width of response obtained. Center the sweep at the center frequency for sound.

2. Couple the marker generator to the same point as the sweep, through a separate small capacitor. The marker will be used to

identify the center frequency and the band width on the response trace.

3. If the tube immediately preceding the demodulator is operated as a limiter, connect the vertical input of the oscilloscope to the high side of the limiter grid resistor as shown by Fig. 7-8. Leave the scope connection here while aligning all the couplers and the sound takeoff if the takeoff is tuned. To avoid distortion of the response with the scope connected to the limiter grid it is necessary to use in series with the vertical input a resistor R of 50,000 ohms or more.

If there is no limiter tube, the response must be measured at the output of the demodulator. Connect the vertical input to point X of Fig. 7-3 or Fig. 7-4, or across the large capacitor C used with a ratio detector. Here it is not necessary to use the high resistance in series with the scope lead.

If there is no point corresponding to X of the diagrams, and a readable response cannot be obtained across the large capacitor, connect the vertical input of the scope to the balanced output point marked Y in Fig. 7-3 or Fig. 7-4. With this latter connection it is necessary that the secondary of the demodulator transformer be detuned, otherwise the output will be zero at the center frequency for sound. The detuning may be done by turning the alignment slug a turn or two in either direction, or by connecting a resistor of about 500 ohms across the secondary, or by connecting across this winding a capacitor of 2 or 3 mmfd or greater capacitance.

4. Adjust all the interstage couplings in the sound system, also the sound takeoff, to obtain the overall response features mentioned in connection with Fig. 7-7.

Demodulator Alignment with Oscilloscope.—Alignment of the demodulator transformer is a more intricate operation than alignment of preceding couplers in the sound system. It might be considered also a more important alignment for the reason that misadjustment may cause troubles other than a mere reduction of audio output. The trace showing demodulator output is not a single- or double-peaked curve but is of a form called an S-curve which indicates the manner in which frequency modulation is changed into amplitude modulation suitable for the audio amplifier and loud speaker. We shall commence this work by

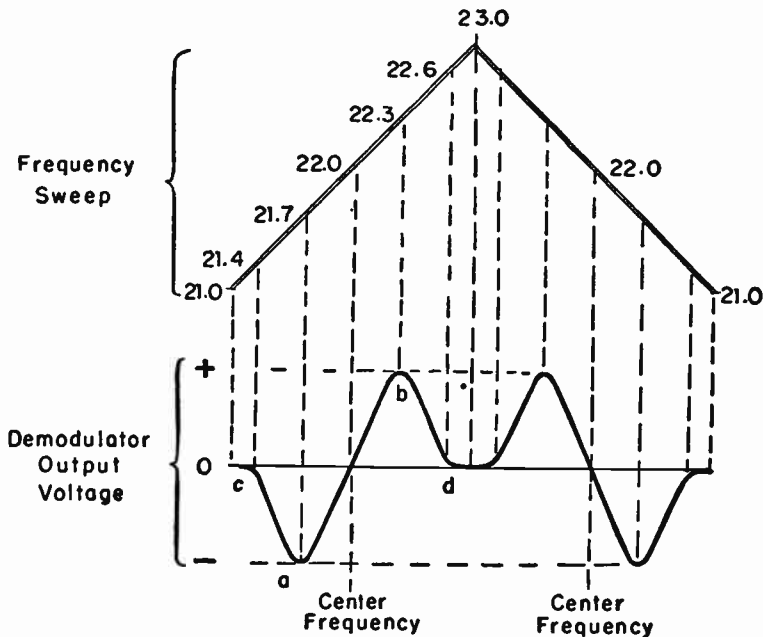

Fig. 7-9.—Relations between frequency sweep during 1/60 second and a voltage trace appearing on the oscilloscope.

examining a few of the response traces which may be obtained, and how they are obtained.

To begin with, assume that a sweep generator is coupled to the control grid of any tube ahead of the demodulator, as in Figs. 7-5 and 7-6. Assume also that the center frequency for sound is 22.0 mc, which might be a sound intermediate frequency. If the sweep generator is adjusted for 2 mc sweep width, going 1 mc below and 1 mc above the center frequency, the frequency swing during 1/60 second may be represented as at the top of Fig. 7-9. The frequency will change from 21.0 mc to 23.0 mc and then back to 21.0 mc.

Now we shall connect the vertical input lead of the oscilloscope to the balanced output point of the demodulator, which would be to point Y in Figs. 7-3 or 7-4. Using the internal sweep of the scope, synchronized for 60 cycles per second, we will have a trace of the general form shown at the bottom of Fig. 7-9.

The rather peculiar form of this trace results from two facts. First, the voltage output of the demodulator is zero at the center frequency for sound when the demodulator transformer is correctly aligned, then the voltage becomes negative with frequency deviation in one direction from the center frequency, and becomes positive with deviation in the opposite direction. This accounts for zero voltage each time the sweep goes through the center frequency, and for the voltage slopes on both sides of this frequency.

The second important fact is this: The demodulator transformer and all other interstage and sound takeoff couplings ahead of it have a limited range of frequency response. This is true of any tuned coupling, it has peak response or gain at some one frequency or over a narrow range, and the gain falls off at frequencies lower and higher. The peak response of all these couplings is at the center frequency for sound; 22.0 mc in our example. The turning of the response curve back toward zero at *a* and *b* of Fig. 7-9 results from the falling off of gain in the couplers at frequencies well removed from the center frequency. At *c* and *d* the response of all the couplers has dropped to zero, and we have zero voltage in the demodulator output.

The second half of the voltage curve in Fig. 7-9 repeats the first half with the peaks inverted. This inversion occurs because sweep frequency increases during the first half of the sweep time, and decreases during the second half.

The trace at the left in Fig. 7-10 is simply the first half of the complete trace of Fig. 7-9. This half trace is secured by increasing the horizontal gain of the scope and by using the horizontal

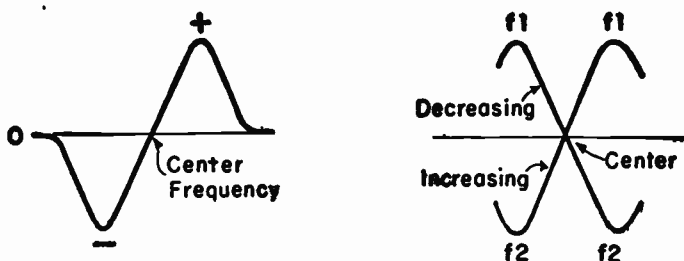

Fig. 7-10.—Single and double S-curves obtained by using the internal sweep of the oscilloscope.

centering control to move the second half of the trace off the screen. This allows a much larger response curve on a screen of any given diameter.

So far, the internal sweep of the oscilloscope has been synchronized at 60 cycles. If the internal sweep is synchronized for 120 cycles per second it is possible to obtain the double trace shown at the right in Fig. 7-10. This trace is made up of the two relatively straight parts in which there is an increasing frequency during the first $1/120$ second, and a decreasing frequency during the following $1/120$ second. The frequencies are alike at the two points marked f_1 and again are alike at the two points marked f_2 . The crossover point of the two curves is at the center frequency for sound. This complete trace is the double S-curve with center crossover which is quite familiar to those who have made visual alignment of f-m sound receivers.

Fig. 7-11 illustrates what may be done when using synchronized horizontal sweep voltage from the sweep generator or any other source, instead of the internal sweep of the oscilloscope. The horizontal sweep frequency rate applied to the horizontal input of the scope is the same as the rate at which frequency varies up and down in the generator output. Usually both these rates are 60 cycles per second.

At A the forward and return traces are not quite synchronized. Adjustment of a phasing control will superimpose the two traces

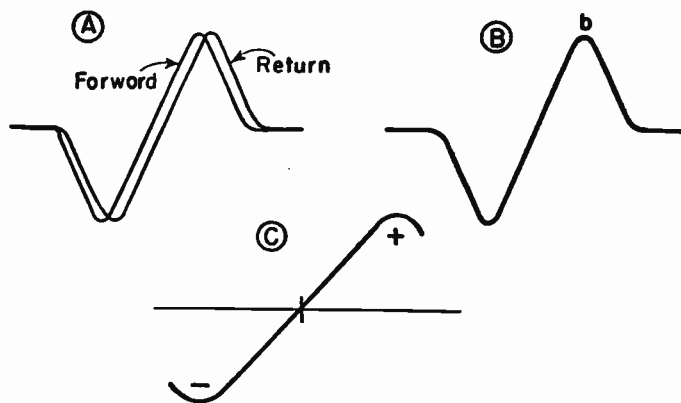

Fig. 7-11.—S-curves obtained when using a synchronized sweep voltage for the horizontal input of the oscilloscope.

so they appear as at *B*. There will be a single curve if the forward trace is exactly like the return trace. The forward trace is the first half of the voltage curve shown in Fig. 7-9. The return trace is the second half of that curve, reversed in its relations between frequency and time. This reversal occurs whenever we use a synchronized sweep frequency at the horizontal input of the oscilloscope.

At *C* in Fig 7-11 is shown the effect of reducing the extent of frequency sweep in the generator. As an example, were the original sweep to be something like 2 mc from lowest to highest frequency for producing the trace at *B*, reducing the sweep to about 0.5 or 0.6 mc would produce the trace at *C*. This latter trace shows enough of the S-curve to allow making all adjustments needed during alignment. It is easier to work with than the more extended curve at *B*, chiefly because distinct marker pips can be formed with less output from the marker generator, and because these pips are easier to follow as they are shifted up and down the curve.

Fig. 7-12 illustrates some features which are desirable in the S-curve of a demodulator. The center frequency for sound, to which all the couplers are aligned, should be midway between the lower and upper peaks. The parts of the curve which are below and above the center frequency should be of nearly the same shape or form, they should be symmetrical. These two things are attained largely by correct adjustment of the secondary in the demodulator transformer. The amplitudes or distances of the two peaks above and below the center should be equal. This too depends to a great extent on adjustment of the secondary.

Usual recommendations are that the total separation between peaks be something between 400 and 600 kilocycles or between 0.4 and 0.6 megacycle. This separation requires correct adjustment of the primary. Equal spacings of the two peaks to the left and right of the center point depend on correct adjustment of both primary and secondary of the demodulator transformer. To have high quality of sound reproduction the curve should be nearly straight or linear for as far as possible above and below the center point. The straight part of the curve should extend at least 75 kilocycles each way from the center to have audio output

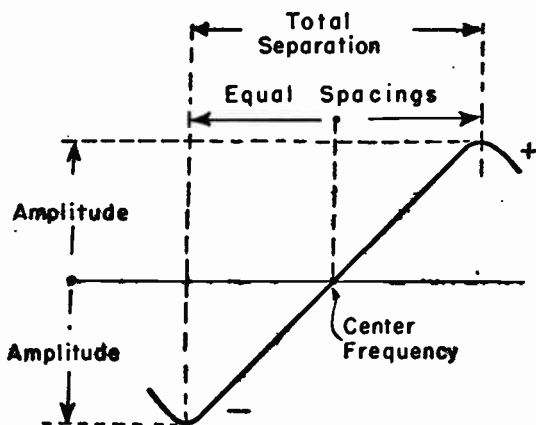

Fig. 7-12.—Features of a demodulator S-curve which are affected by alignment adjustments.

amplitudes which correspond closely to deviations of frequency in the f-m sound signal. A linear curve is obtained by careful adjustment or alignment of the primary. Finally, when all the other requirements are at least fairly well satisfied, it is desirable to have maximum amplitudes of the two peaks above and below the center. This is a matter of primary adjustment.

Everything which has been mentioned as dependent on correct adjustment of the primary in the demodulator transformer depends also on correct alignment of all preceding couplers. Unless the response of all these couplers is centered at the center frequency for sound, and unless the overall response from all of them has sufficient band width, it is impossible to obtain the desired response from the demodulator.

The steps in alignment of the demodulator transformer with the oscilloscope are as follows:

1. Couple the output of the sweep generator to any of the points specified for a marker type generator in Figs. 7-5 and 7-6. Set the center frequency of this generator at the center frequency for sound, which is either the sound intermediate frequency of the receiver or else, for intercarrier sound, is 4.5 mc. Commence with a sweep of 1 to 2 mc and later reduce it in obtaining an S-curve like that in Fig. 7-12.

2. Couple the output of a marker generator to the same point

as the sweep generator, but, as always, through a separate capacitor. The marker generator will be used to identify the center frequency point, the frequencies at the two peaks, and to what frequencies the straight central portion of the curve extends.

3. Connect the vertical input of the oscilloscope, through a filter probe, to the point of balanced output from the demodulator, which is point Y in Fig. 7-3 or Fig. 7-4. The internal sweep of the scope may be used to obtain any of the S-curves shown by Figs. 7-9 and 7-10. Synchronized sweep from the generator or a separate source may be used to obtain S-curves as shown by Fig. 7-11. With the marker generator tuned to identify the center frequency for sound, the center frequency and sweep width of the sweep generator may need slight readjustment for correct placing of the S-curve on the screen.

After aligning the secondary of the demodulator transformer in an intercarrier sound system always make a test with all instruments disconnected and while receiving a regular picture or pattern from a transmitting station. If there is a distinct buzzing sound which is not due to having the contrast control too high, it may be due to misalignment of the demodulator transformer secondary. A test is to shift the secondary adjustment slightly, first one direction and then the other. If there is a point of maximum sound signal volume and minimum or zero buzz in between points of relatively large buzz, this is the correct point of adjustment for the secondary.

Chapter 8

ALIGNMENT OF TUNERS

The tuner section contains the r-f amplifier, the mixer or converter, and the r-f oscillator. There may or may not be tuned coupling circuits between the antenna terminals and the input to the r-f amplifier. There always are tuned couplings between r-f amplifier and mixer, and the oscillator circuit always is tuned. Alignment of these circuits ordinarily is required less often than in the video i-f and sound amplifiers. Need for alignment is indicated when it is impossible to obtain satisfactory pictures and sound by manipulation of a fine tuning or sharp tuning control. Alignment is required when any parts have been replaced in tuned circuits, and may be required when there is replacement of any tubes in the tuner section.

Because the electrical and mechanical construction of a tuner determines the manner in which alignment must be carried out it will be well to examine a few tuners which illustrate the more common designs.

A great many tuners employ some or all of the features shown by Fig. 8-1. This is a rotary switch type with tuning inductors mounted on or close to the switch wafers. Connections suitable for each channel are completed by four contacts on four switch rotors. These contacts are indicated by arrowheads. The tuning inductances in the plate circuit of the r-f amplifier and in the control grid circuit of the mixer consist of a series of small wire loops and coils.

With the channel selector set for channel 13 the switch points are on contacts *a-a*. The adjustable inductance loops *b-b* are active, and all remaining loops and coils are shorted between the switch points and the bottom connections. As the channel selector is set for channels of lower and lower numbers the switch points move downward on the diagram, and leave additional inductance sections in the active circuit until, on channel 2, all the sections are active.

The only adjustable inductors are at *b-b* and *c-c*. Inductors

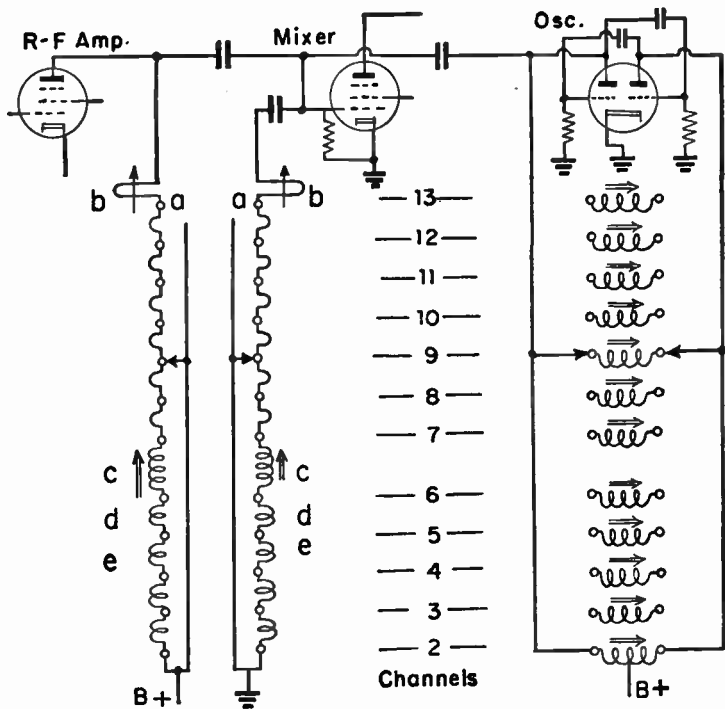

Fig. 8-1.—Rotary switch tuner with r-f adjustments for some channels and oscillator adjustments for all channels.

b-b are adjusted with the switch set for channel 13. Remaining inductance loops between this switch setting and the setting for channel 7 and not adjustable. Consequently, the adjustment or alignment of inductors *b-b* affects the tuning or response on all channels from 13 to 7, inclusive.

When the switch is moved from channel 7 to channel 6 the adjustable inductors *c-c* are brought into the active circuit. These two inductors are aligned with the switch set for channel 6. The inductances at *c-c* are so much greater than those at *b-b* that whatever alignment has been made with *b-b* has negligible effect when making adjustments at *c-c*. The inductors which are between the switch points on channels 6 and 2 are not adjustable. Consequently, the adjustment of inductors *c-c* affects the response on all channels from 6 to 2 inclusive.

In rf-mixer tuned couplings of the general type illustrated

there may be no field adjustments at all, with all channels factory aligned. There may be only the end adjustments at *b-b* or only the center adjustments *c-c*. In some tuners all the small inductor coils for channels between numbers 6 and 2 may be adjustable. Then the inductors at *d-d* would be adjusted with the switch set for channel 5, those at *e-e* with the switch set for channel 4, and so on.

When alignment of one inductor affects the tuning of several channels it is a general rule to align that inductor with the switch set to include that one inductor or the fewest possible additional ones in the active circuit. It may be found, however, that an adjustment made with this switch setting throws some of the other affected channels too far out of alignment. Then it is necessary to make a compromise adjustment which will give satisfactory tuning for all affected channels, although none of them may be precisely what you might desire.

In the oscillator circuit of Fig. 8-1 there are separate inductors for each of the channels. These inductors are brought into the oscillator plate-grid circuit, one at a time, by rotation of the channel selector switch. Every one of these inductors may be separately adjustable, as shown, or there may be adjustments only for the coils in the low-band channels. In any case, adjustment of the oscillator coil for any one channel is made independently, with the switch set for that one channel. When oscillator coils are mounted close together, the resonant frequency of one may be slightly affected by adjustment of nearby coils. Such slight changes of resonance are corrected during the recheck of performance which should follow every job of alignment.

Fig. 8-2 shows another tuner which cuts in successive sections of inductance as the channel selector switch is moved from channel 13 toward channels of lower numbers. This is accomplished by switch rotors which are shorting segments, represented in the diagram by the shaded vertical bars. The contacts for all inductor sections not in the active circuits for r-f plate and mixer grid are shorted together by the switch rotors. In this particular tuner there is an additional tuned circuit between the antenna coupling transformer and the control grid of the r-f amplifier.

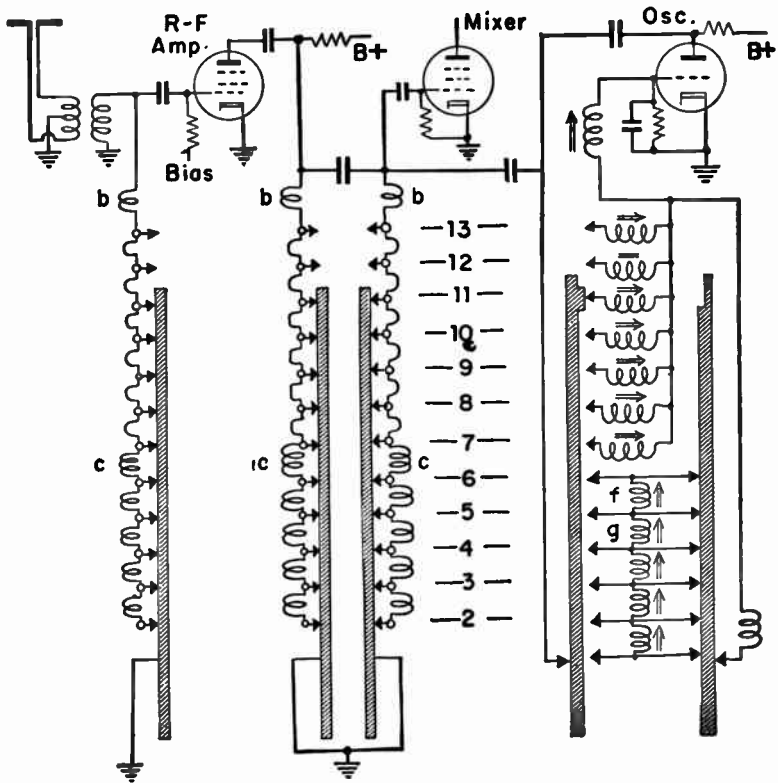

Fig. 8-2.—Tuner with shorting rotary switch and tuning in the antenna coupling.

Inductors *b-b-b* may or may not be adjustable. If adjustable, they are aligned with the channel selector set for channel 13. Inductors *c-c-c* may or may not be adjustable. If adjustable, they are aligned with the switch set for channel 6. If inductors shown below *c-c-c* in the diagram are adjustable, they are aligned with the switch set on the contacts just above each inductor as it is handled. Although the switches in Figs. 8-1 and 8-2 are of different type, the general method of adjustment and the order in which channels are aligned would be the same for both tuners.

For the oscillator in Fig. 8-2 we again have individual separately adjustable coils for each channel. As the switch rotors

are moved downward on the diagram, oscillator coils for channels 13 to 7 are successively brought into the active circuit by the extension on the switch rotor on the left of these coils. Only one coil is in circuit at a time.

When the switch is brought to the position for channel 6, the short-circuiting rotor on the right of the oscillator coils has opened its side of coil f and this coil now is connected to the oscillator plate through the rotor on the left. Remaining oscillator coils for channels of still lower numbers are similarly brought into the oscillator circuit by movement of the switch rotors.

Fig. 8-3 illustrates features of turret tuners such as found in many receivers. The stationary contacts which are in the tube circuits are represented by arrowheads. Within the broken line which is between the arrowheads are the coils for any one channel. These coils usually are mounted together on an insulating strip which clips into place on the rotating member of the turret. There is a similar strip, with its set of coils,

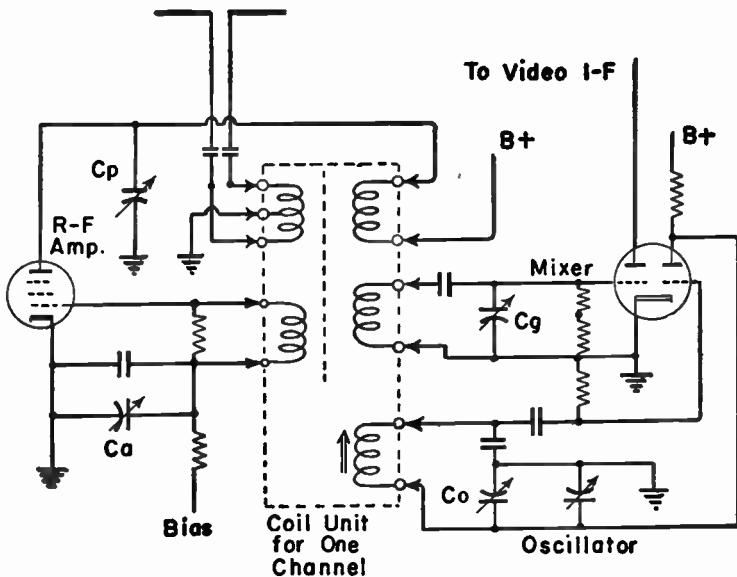

Fig. 8-3.—Overall alignment adjustments affecting all channels, as used in a turret tuner.

for each of the other channels. In the design shown here, only the oscillator coil has an adjustable core which may be used for alignment. In different designs there may be adjustable cores in one or more of the other coils, or there may be adjustable cores in the coils for some channels and not in those for other channels.

If there are no adjustments in the coils, and it is impossible to secure a satisfactory response on some channels by means of other adjustments, the coil strip must be replaced. Sometimes the strips for various channels become mixed as they are inserted on the turret, and must be straightened out.

To be especially noted in Fig. 8-3 are certain trimmer capacitors which form overall adjustments affecting all channels. Trimmer C_a is in the control grid circuit of the r-f amplifier. Capacitor C_p is in the plate circuit of this amplifier. Capacitor C_g is in the control grid circuit of the mixer tube. These three capacitors affect the response of the r-f stage, they affect the distribution of gain with frequency between the antenna and the mixer grid. Adjustment of C_a , C_p , and C_g should be made to give the best possible compromise in the r-f responses for all channels. The response on every channel must come within certain limits which will be specified later, but the responses need not be alike for all channels.

Adjustable capacitor C_o of Fig. 8-3 is an overall adjustment for the oscillator on all channels. Ordinarily it is the only adjustment which need be altered for oscillator alignment, although the coil slugs for some channels may need adjustment when those channels cannot be brought within correct limits by the overall trimmer adjustment. The adjustable capacitor at the right of C_o is a fine tuning or sharp tuning adjustment for the operator.

When a tuner such as shown by Fig. 8-3 has once been correctly aligned for all channels with certain settings of the trimmer capacitors, any realignment such as necessary upon replacement or aging of tubes should be made by readjustment of the trimmers alone, not by adjustment of coil slugs.

Adjustments which affect the overall response of all channels are not always so plainly apparent as with the trimmer capacitors just shown. Looking back at Fig. 8-1 it may be seen

that the oscillator coil for channel 2 remains connected between the oscillator plates for all other channels. For example, the switch rotor contacts are shown set for channel 9, but the bottommost oscillator coil still is in circuit. As a consequence, adjustment of this coil for channel 2 will affect the oscillator frequency on all channels. If all oscillator coils are to be re-aligned, the work should start on channel 2. Were any other channel aligned before number 2, adjustment for this channel might upset some or all the others.

Fig. 8-4 shows connections for a two-band continuous tuner, in which there is a continuous change of frequency response through the low-band channels 2 to 6, and another continuous change through the high-band channels 7 to 13. There are completely separate sets of tuning coils for each band, with the changeover made by the switches marked *Low-High*. Tuning through each band is accomplished by the movable cores of the coils. All these cores are moved together by the channel selector. There is a low-band coil 1 and a high-band coil 2 in the plate circuit of the r-f amplifier. There is another pair of

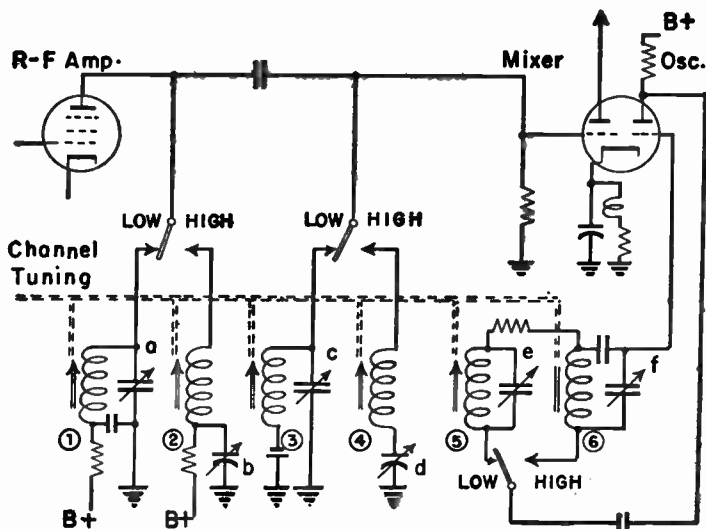

Fig. 8-4.—Two-band continuous tuner with overall adjustments on each tuned circuit

coils, 3 and 4 in the grid circuit of the mixer. There is a third pair of coils, 5 and 6, for the oscillator.

In this tuner there are trimmer capacitors which affect the response throughout an entire band of channels. Trimmer *a* tunes the r-f amplifier plate on channels 2 through 6, while trimmer *b* acts similarly on channels 7 through 13. Trimmers *c* and *d* act in the same manner for the low band and high band on the mixer grid circuit. Trimmers *e* and *f* vary the oscillator frequency for the low-band and high-band channels respectively.

In addition to the trimmer capacitors shown in Fig. 8-4, tuners of this general type usually have adjustments for the coil slugs which are moved by the channel selector. Positioning of the slugs with reference to the coil windings usually is a preliminary adjustment. It may be made by turning the slugs to bring them some certain distance outside the coil form or a support, or to bring them to some position with reference to other parts as measured in fractions of an inch. When the coil cores have been adjusted in this manner, they are thereafter moved together by the channel selector. This adjustment of coil cores with reference to the selector mechanism should be required only when there has been replacement of major parts of the tuner. It should be possible to compensate for tube replacements by adjusting the trimmer capacitors.

Fig. 8-5 shows connections for a continuous tuner covering without break the frequencies from 44 mc to 216 mc, which include the television channels and also f-m broadcast and other radio services in the range between channels 6 and 7. The diagram represents a Du Mont Inputuner which is developed around the three-gang variable inductor called the Mallory-Ware Inductuner. The inductor unit is shown within the broken line.

Capacitors *Ca*, *Cb* and *Cc* are adjusted to obtain the correct r-f response from antenna through the mixer. The correct response shows a slight double peak with the peaks about 4.5 mc apart, with the video carrier frequency at or near one peak and the sound carrier frequency at or near the other peak when tuned for channel 3. The band pass frequency width is adjusted by spreading or squeezing the exposed end

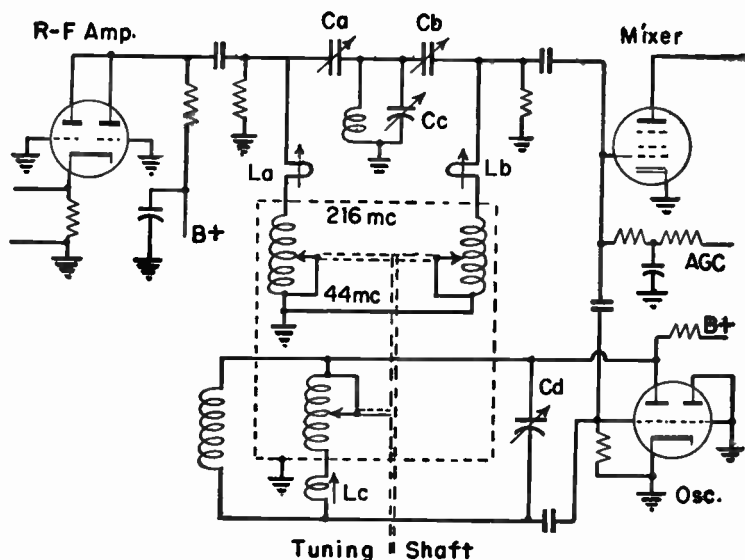

Fig. 8-5.—Circuits and adjustments in a Du Mont Inputuner.

turns *La* and *Lb* with the tuner set for channel 13. This band pass must be no less than 4.5 mc and no more than 6.0 mc.

The oscillator is tracked by adjustment of trimmer capacitor *Cd* and end turns *Lc*. Capacitor *Cd* is adjusted with the tuner set for one of the low-band channels, usually channel 4, while inductance turns *Lc* are adjusted with the tuner set for channel 13.

Types of Adjustable Inductors.—Tuning coils which are to have considerable inductance, as required on low-band channels, often are provided with screw type adjustable slugs of powdered iron such as generally used in standard broadcast circuits. For coils in high-band channels the screw slugs often are made of brass and sometimes of copper-iron mixtures. Turning an iron slug farther into the coil turns increases inductance and lowers the resonant frequency. Brass or other non-magnetic metal has the opposite effect, turning it farther into the coil turns lessens the apparent inductance and raises the frequency.

Where the inductors are single turns or small loops the adjustment may be with brass screws turned closer to or farther from

the inductors. A similar principle is employed by providing a shorted single turn of wire which may be moved toward or away from the high side of a coil to vary the effective inductance.

The inductance of space wound self-supporting coils may be altered by squeezing the turns to get them into less overall length or by spreading two or more turns to increase the length. Shortening a coil increases the inductance and lowers the frequency, while lengthening it lessens inductance and raises frequency. The squeezing or spreading should be done with a non-metallic tool if the response is being watched during adjustment.

An inductor often used where very small inductance is needed consists of a hairpin-shaped loop of wire. Spreading the sides of the loop farther apart increases the inductance, squeezing them closer together decreases the inductance. Inductance loops may be provided with a short-circuiting slider which can be moved toward or away from the closed end of the loop. Moving the slider toward the closed end of the loop increases the inductance and lowers the resonant frequency, while moving the slider toward the open end or toward the terminals of the loop has the opposite effect. The slider, once adjusted, may be held in place by solder or cement.

There is capacitance between any two wire leads which run to the terminals of an inductor or a capacitor. This lead capacitance always is part of the tuning capacitance for the circuit. Moving the leads farther apart lessens the capacitance and raises the resonant frequency, while moving them together increases capacitance and drops the frequency. If the leads are close together, say within one-eighth inch, a small change of spacing makes a considerable change in the resonance value at high frequencies.

Several different means for adjustment of inductance and capacitance may be found in a single tuner. One method may be used for low-band inductors and another for high-band inductors. or more than two methods may be employed in different circuits or for different channels.

Tuning Wand.—Sometimes there is a question as to whether inductance or capacitance in a tuned circuit should be increased or decreased to make the circuit resonant at a certain frequency or to change a response in some desired manner. The question often may be answered by using a tuning wand which consists

of an insulating rod with a powdered iron slug on one end and on the other end a slug of non-magnetic metal such as brass, copper, or aluminum.

Bringing the iron end of the wand close to or into the end of a tuning inductor increases the inductance, while the non-magnetic end decreases the inductance. The wand is used while feeding into the tuned circuit or amplifier a signal at the desired frequency, and observing the response on an oscilloscope or electronic voltmeter. If the iron end of the wand causes the response to increase, the tuned circuit needs more inductance or more capacitance. If the non-magnetic end causes an increase of response the circuit needs less inductance or capacitance. If neither end of the wand causes appreciable change when brought fairly close but not into the inductor, the circuit needs no change of inductance or capacitance and already is resonant at the applied frequency.

Tuning wands may be purchased at small cost. One may be assembled from the iron core of a discarded coil, any cylindrical piece of non-magnetic metal, a short length of insulating rod, and cellulose tape to hold the parts together and cover the metal ends. For use around television inductors the diameter should be between 1/8 and 3/16 inch.

Matching of Generator Impedance.—When aligning or testing the tuner section the input from the signal generator or generators is connected to the antenna terminals of the receiver, the terminals to which a transmission line connects for normal reception. When the receiver is one designed to operate from a 300-ohm balanced transmission line it is desirable that the output impedance of the generator be matched as closely as possible to this 300-ohm input impedance of the receiver. Otherwise there will be standing waves and reflection losses at certain frequencies. Some generators have output terminals between which

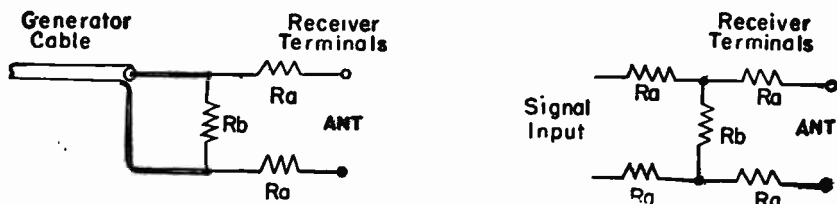

Fig. 2-6.—Impedance matching pad (left)

Attenuator pad (right).

there is an impedance of 300 ohms, or have a switch for providing this output impedance. Other generators should be used with an impedance matching pad or network between their output and the antenna terminals of the receiver.

An impedance matching pad may be made up from 1/4-watt carbon resistors as shown at the left in Fig. 8-6. The accompanying table lists resistance values suitable for use with generators having various output impedances.

Generator Output Impedance	Resistors R_a (each unit)	Resistor R_b
100 ohms	120 ohms	130 ohms
75 ohms	130 ohms	91 ohms
50 ohms	130 ohms	56 ohms
30 ohms	150 ohms	31 ohms

With these resistance values the impedance presented to the generator will be slightly greater than its own output impedance, and the impedance on the receiver end will be approximately 300 ohms. The resistances used are standard or preferred values which are readily available.

During some tests it is desirable to simulate a weak signal from the antenna or to have a weaker signal than available with the generator attenuator turned all the way down. The weak signal may be secured with one or more sections of attenuator pad as shown at the right in Fig. 8-6. Values of R_a and R_b are the same as in matching pads previously described. Instead of using the unbalanced H-pad as for matching, the attenuator sections consist of balanced pads with equal values of series resistors R_a on both sides of the shunt resistor R_b . For use between the transmission line and receiver terminals connect the line to the left-hand ends of resistors R_a . That is, terminate the net on its input side with resistors R_a . For use between a generator and the receiver, terminate the net on its left-hand input side with a shunt resistor R_b and connect the generator across this resistor.

R-f and Antenna Alignment.—Alignment of a tuner includes two major operations. One consists of adjusting the coupling which is between the r-f amplifier and mixer, also the coupling between antenna and r-f amplifier if this coupling is tuned. The second operation consists of aligning the circuit of the r-f oscil-

lator. If both operations are required they might be performed together, channel by channel, while using the generator frequencies for each channel. However, because of differences in methods for the two operations, we shall first consider the adjustment of r-f and antenna couplings, later taking up the matter of oscillator alignment.

With signal input to the antenna terminals and output measured at the mixer, the r-f response may be double-peaked as at the left in Fig. 8-7, or broadly single peaked as at the right, or it may be nearly flat topped. In any case there must be sufficient band width to accommodate both the video carrier and sound carrier at reasonable levels on the response. This means, in general, that both these carrier frequencies must come somewhere between the peak or 100% response and a point no lower than 70% of maximum. So long as this primary requirement is met, it is desirable to have maximum possible gain. If the response is double-peaked the dip or valley between peaks must not drop lower than 70% of maximum gain. For most receivers it is desirable that both the video and the sound carriers be at points of approximately equal gain. Sometimes the sound carrier has to be a little higher than the video carrier, but not more than 20% higher.

It is evident from Fig. 8-7 that, to accommodate both carriers as specified, the total width of the response from zero to zero will be much more than the width of a channel. Unless the fre-

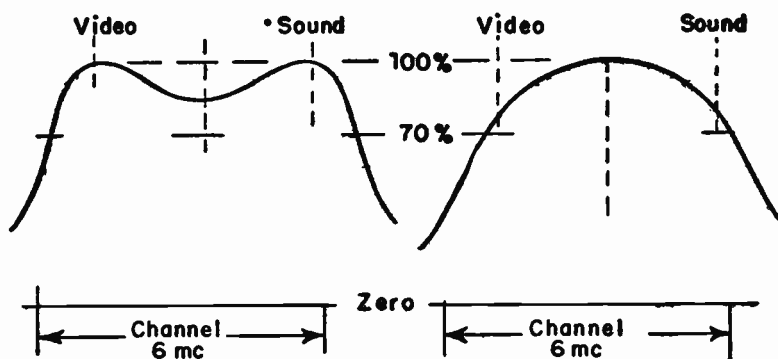

Fig. 8-7.—R-f responses may be double-peaked, broadly single-peaked, or may be flat-topped.

quency swing of the sweep generator can be made at least 10 mc it seldom will be possible to bring both sides of the response onto the oscilloscope screen. Most often, the center of the response curve is to be midway between the video and sound carriers, as shown in the diagrams, but sometimes it is at the center frequency of the channel. This will bring the sound carrier somewhat lower down than the video carrier. What has been said about r-f responses applies whether the receiver sound section operates on the sound intermediate frequency or on the inter-carrier beat frequency.

In many receivers the r-f band width is fixed by construction and initial factory adjustment of coupled circuits. In others it is possible to vary the band width by changing the degree of coupling. The closer the coupling, as between the r-f amplifier plate circuit and mixer grid circuit, the greater will be the band width but the less the gain at the peaks. If there is inductive coupling between coils in the two circuits, moving the coils closer together usually increases the coupling but may decrease it if the coils are wound opposing.

Windings in an overcoupled transformer most often are separately tuned to the same frequency, about midway between the video and sound carriers. This is done by detuning one winding or shunting it with about 300 ohms resistance while the other winding is adjusted for resonance. Then the first winding is detuned or shunted while the second is adjusted for resonance at the same frequency. If the coupling is adjustable it then is varied to bring the response peaks into the desired relation to the two carrier frequencies.

When there is capacitive coupling between two tuned circuits an increase of capacitance broadens the band and drops the gain. In some receivers the coupling capacitance is only that between two lengths of wire, one in each circuit. Changing the separation between these insulated wires varies the coupling.

R-f Alignment with Oscilloscope.—Following are the steps for observation of the response from the antenna input terminals through the mixer by using the oscilloscope as an output indicator.

1. If the automatic gain control operates on the r-f amplifier, override the control voltage by means of a battery adjusted for

a fixed bias of 2 to 4 volts, as described in connection with video i-f alignment.

2. Remove the r-f oscillator tube from its socket if this tube is not on a series heater string. If the heater is in series, cut out the oscillator by connecting a fixed capacitor of about 0.001 mfd from its grid to ground.

3. If there are traps on the antenna input or on the r-f amplifier circuits these traps should be detuned well beyond any television frequencies or else shunted with fixed resistors of about 1,000 ohms resistance.

4. It may or may not be necessary to detune the coupling between mixer plate and the first video or video-sound i-f amplifier. To avoid possible effect on the r-f response, it is well to connect between the first video i-f control grid and ground a fixed capacitor of between 0.0005 and 0.001 mfd capacitance.

5. Connect the sweep generator to the antenna terminals of the tuner. If there is a length of transmission line or cable between the tuner terminals and the receiver terminals to which the transmission line normally is connected, it is advisable to connect the generator directly at the tuner and to temporarily disconnect the short length of line from the tuner. If this length of line cannot be disconnected from the tuner, connect the generator to the external receiver terminals and work through the short connection to the tuner.

If the receiver is designed for a 72-ohm coaxial transmission line or cable, connect the high side of the generator output to the antenna terminal of the receiver and connect the shield of the output cable to the ground terminal. If the receiver is designed for a 300-ohm balanced line, and the generator does not have a 300-ohm balanced output, use an impedance matching pad as described earlier in this chapter.

Tune the sweep to a center frequency which is midway between the limiting frequencies for each channel aligned, or to a frequency about 0.5 mc higher. Set this generator for a wide sweep, 10 mc or more. The center frequency and sweep width may be readjusted later to best suit the response on each channel.

6. Couple the marker generator very loosely to the antenna terminal of a receiver designed for 72-ohm input or to either of the antenna terminals for a 300-ohm balanced input. Coupling

methods were described in connection with alignment of video i-f amplifiers. The signal which reaches receiver circuits from the marker generator must be the weakest which will produce pips barely visible on the trace. Use the marker generator unmodulated.

7. The vertical input of the oscilloscope may be connected to any one of several points. When the mixer tube is a triode the usual connection of the scope is to the grid circuit of the mixer. This connection should not be made directly to the grid pin or grid terminal of the socket, rather to some point removed from the grid by several thousand ohms but still well above the ground connection of the grid resistor. Suitable test jacks or clips are

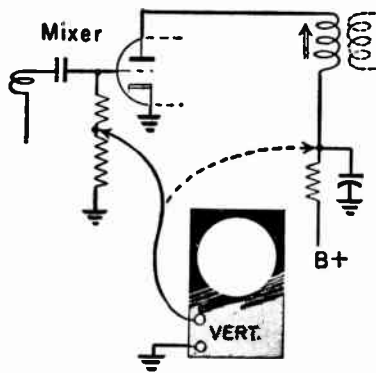

Fig. 8-8.—Oscilloscope connected to grid resistor of a triode mixer.

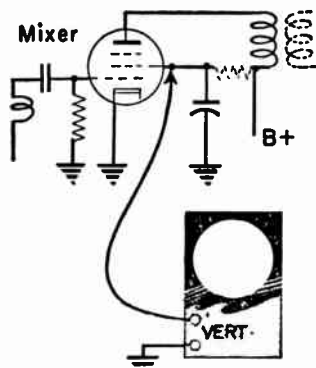

Fig. 8-9.—Oscilloscope connected to the screen grid of a pentode mixer.

provided on some receivers. In addition to the resistance in the grid circuit there should be at least 10,000 to 20,000 ohms in a resistor connected in series with the oscilloscope cable. Such resistance is provided when using the filter probe described earlier. The connection is shown by Fig. 8-8.

On some receivers using a triode mixer a satisfactory response is obtained by connecting the oscilloscope into the mixer plate circuit. This connection should be below the plate load, which may be a transformer primary or a coupling coil, but above the decoupling resistor and capacitor on the line going to B+.

When the mixer tube is a pentode the oscilloscope may be connected to the screen grid of this tube to give a satisfactory

oscilloscope trace with most tuners. With a pentode mixer it is possible also to use the same oscilloscope connections as mentioned for triode mixers. Connection to the screen grid is shown by Fig. 8-9. It should be directly to the screen terminal of the socket or to the screen pin of the tube, not to any point beyond a decoupling resistor or capacitor in the screen circuit.

8. When the generators and scope are connected for signal input and output, make sure that there are secure connections from all ground terminals on the instruments and from the receiver chassis to a common ground. Leave the contrast control in its usual operating position. Set the channel selector for the first channel to be aligned, this depending on construction of the tuner as described in earlier pages. Turn on the instruments and the receiver, then allow a warm up period of at least 15 minutes before commencing any adjustments.

9. Align trimmer capacitors, coil slugs, or other types of inductance and capacitance adjustments in antenna and rf-mixer couplings to obtain desirable response. If the marker generator provides only one frequency at a time, tune this generator alternately to the frequencies of video and sound carriers in the channel being aligned. The response must be shaped to bring both markers within the limits discussed in connection with Fig. 8-7. Keep in mind that adjustment of any one inductor affects chiefly the amplitude or gain at the frequency to which that inductor is tuned. One inductor may affect the peak for the video carrier and another inductor may affect the peak for the sound carrier. Unless you have detailed instructions relating to a specific receiver being handled, some trial and experiment will be necessary to determine the effect of various adjustments on the response. Adjustments which affect the degree of coupling between tuned circuits always affect the band width primarily, and also affect the gain to some extent.

10. With alignment completed for the first channel, set the channel selector for the next channel which should be aligned and proceed as before—being careful to use video and sound carrier frequencies for the channel being worked on. After aligning all channels for which there are adjustments, change the channel selector and marker frequencies through all the channels for a re-check and touch-up adjustments where needed.

The accompanying table lists video and sound carrier frequencies, also the channel limit frequencies, for all channels in the low and high bands. Although channel 1 is not in use, its frequencies are included because they may be needed for a preliminary setting on some tuners.

Notes: Should the response persist in showing dips at some frequencies, rather than being a relatively smooth curve, this may be due to the effects of traps on the antenna or r-f circuits. These traps should be detuned as explained earlier. Dips may result also from absorption and attenuation in the control grid circuit of the first video i-f amplifier. This trouble may be prevented by connecting a fixed capacitor of 0.0005 to 0.001 mfd from the control grid of the video i-f amplifier to chassis ground, or possibly by connecting a similar capacitor from the mixer plate to ground when the oscilloscope is not connected to the mixer plate circuit.

Channel No.	CHANNEL FREQUENCIES, MEGACYCLES		
	Frequency Limits	Video Carrier	Sound Carrier
1	44 - 50	45.25	49.75
2	54 - 60	55.25	59.75
3	60 - 66	61.25	65.75
4	66 - 72	67.25	71.75
5	76 - 82	77.25	81.75
6	82 - 88	83.25	87.75
7	174 - 180	175.25	179.75
8	180 - 186	181.25	185.75
9	186 - 192	187.25	191.75
10	192 - 198	193.25	197.75
11	198 - 204	199.25	203.75
12	204 - 210	205.25	209.75
13	210 - 216	211.25	215.75

Always align the tuner with all its shielding in place, if this is possible. A duplicate shield with cutouts for reaching adjustments may be used during alignment. If a shield cannot remain in place, always make a re-check of the response on all channels after the regular shield has been put back.

For making tuner adjustments use only screwdrivers or wrenches made entirely of hard fibre or plastic. Even a small metal tip may upset the tuning.

R-f Trap Alignment.—Traps on the antenna input or on the r-f amplifier grid circuit are used for reduction of interference. The interference may come from nearby amateur transmitters, from f-m broadcasters if evident on low-band channels, from a sound carrier on channel 7 if interference is only on channel 5, from a sound carrier on channel 10 if interference is on channel 6, from aircraft beacons and landing guides, and from any other signals whose fundamental frequency or a strong harmonic comes within the reception range of some channels.

If the interfering frequency is known, the trap or traps may be adjusted by using a signal generator and electronic voltmeter as described later. If the interfering frequency is not known the trap adjustment may be made with the receiver operating and connected to a regular antenna. To make such an adjustment proceed as follows:

1. Set the channel selector to the channel on which interference is most evident and bring in a picture or test pattern by usual adjustment of contrast, brightness, and fine tuning controls.

2. If there is only a single trap circuit, adjust it for minimum interference. If there are two trap circuits, as with one on each side of a 300-ohm balanced antenna input, both traps are adjusted together and in the same direction to leave minimum interference. Then turn either adjustment about a half turn clockwise or counter-clockwise, and readjust the other side for further reduction of interference if possible. If there is further reduction, turn the first trap adjustment farther in the original direction and again readjust the second one. If this alternate adjustment increases the interference, start over again by turning the first adjustment a half turn in the opposite direction and then try readjusting the second one. Continue thus until there is least possible interference.

For trap adjustment with instruments the method is as follows:

1. Set the channel selector to the channel where interference is expected or is most evident.

2. Connect an electronic voltmeter from the high side of the video detector load resistor to ground, using a low-voltage d-c scale.

3. Connect a marker type constant-frequency signal generator

to the antenna terminals of the tuner or receiver. Unless the generator output impedance matches the tuner impedance use a matching pad of the type shown in Fig. 8-6. Tune the generator to the interfering frequency.

4. Adjust the trap or traps for minimum reading on the voltmeter. With two trap circuits follow the method of alternate adjustment described for alignment on a station signal.

Effects of Oscillator Frequency.—Fig. 8-10 illustrates how intermediate frequencies actually applied to a video i-f amplifier will vary with changes of frequency in the r-f oscillator. To have definite frequency values for our examples we shall assume operation on channel 3 where the video carrier frequency is 61.25 mc and the sound carrier frequency is 65.75 mc. The video i-f amplifier is designed for and correctly aligned for a sound intermediate of 22.1 mc and a video intermediate of 26.6 mc. To provide these correct intermediate frequencies the r-f oscillator must be tuned to 87.85 mc for channel 3. Then the sound and video intermediate frequencies will be at the points shown on the response curve at the top.

Now we shall assume further that the sound section operates with the sound intermediate frequency as its center frequency, and has an effective band pass of about 200 kc or 0.2 mc. With conditions shown by the upper curve the sound intermediate fre-

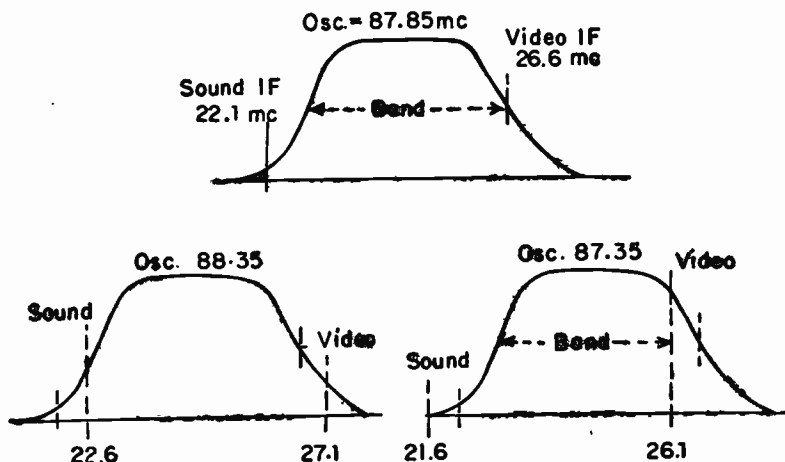

Fig. 8-10.—How r-f oscillator frequency affects actual video and sound intermediate frequencies produced by the tuner.

quency falls in the center of this sound i-f band pass, and the video intermediate frequency is half way down on the high-frequency slope.

In the curve at the lower left the oscillator frequency has been raised one-half megacycle, to 88.35 mc. Subtracting the carrier frequencies from this high oscillator frequency shows that the sound intermediate from the mixer now is 22.6 mc and the video intermediate is 27.1 mc. This sound intermediate is completely outside the band pass of the sound i-f amplifier, and there will be no reproduction of sound. The actual sound intermediate frequency is now too high on the gain curve, and resulting excessive amplification is likely to bring sound bars into the picture.

At the same time, the actual video intermediate frequency falls too low on the response. Low video frequencies will be poorly reproduced, making a dull and lifeless picture. The lack of low frequency gain is likely to cause loss of synchronization or difficulty in adjusting the hold controls.

If the center frequency for the sound section is the intercarrier beat of 4.5 mc the high oscillator frequency will cause the same troubles as mentioned on the video i-f side. There still will be a 4.5 mc intercarrier beat for sound, but the sound portion of this signal is so strong as to cause a strong buzzing sound from the loud speaker, and usually there will be sound bars in the picture.

The curve at the lower right in Fig. 8-10 shows what happens when the r-f oscillator frequency is lowered by a half megacycle, to 87.35 mc. If the center frequency for the sound section is the intermediate frequency from the mixer we again find this frequency completely outside the band pass of the sound i-f amplifier, and there will be no reproduction of sound. With an intercarrier sound system the sound may be weak and require high settings of the volume control, but sound reproduction may be acceptable unless the oscillator is very far off its frequency.

With the oscillator frequency too low, the video intermediate frequency falls too high on the response curve. There is excessive gain at low video frequencies. The effective band pass of the video i-f amplifier has been reduced, there is lack of gain at high video frequencies, and pictures lack definition.

If there is a fine tuning control it may be possible to adjust it to correct the faults of incorrect oscillator alignment on some

channels or possibly on all channels if oscillator alignment is not too far off on some of them. A fine tuning control shifts the actual intermediate frequencies on the video i-f response just as does oscillator tuning. If the incoming signal is weak it is quite probable that the fine tuning may be adjusted for either satisfactory sound or for satisfactory pictures, but not for both at once when the r-f oscillator is out of alignment.

The maximum shift of frequency produced by adjustment of the fine tuning control is least on the lowest-frequency channel and greatest on the highest-frequency channel, this because the capacitance range of the fine tuning control makes a greater percentage variation of frequency at high frequencies than at low ones. This control often will overcome oscillator misalignment on high channels, but not on low ones.

Oscillator Alignment for Sound Intermediate Frequency.—With receivers using the sound intermediate frequency as the center frequency in the sound section the r-f oscillator usually is aligned on a signal introduced at the antenna terminals and measured at the sound demodulator or at the loud speaker. This method is satisfactory because of the narrow band pass in the sound i-f amplifier. Unless the r-f oscillator is aligned almost exactly to its correct frequency, a signal introduced at the sound carrier frequency for a channel will not come through this narrow band pass, and when a maximum signal output is secured it may be assumed that the r-f oscillator is correctly aligned for the channel. When the oscillator is correctly aligned on a sound signal it must be correctly aligned for the video signal in the same channel, since the constant separation of 4.5 mc between sound and video is fixed by the carrier frequencies.

A fairly accurate oscillator adjustment often may be made as follows:

1. Carefully tune in any transmission which is carrying a test pattern and accompanying constant frequency audio tone.
2. Adjust the oscillator slug or other alignment device for the tuned channel to secure maximum sound from the loud speaker. During this adjustment the fine tuning control, if there is one, should be set near the center of its range and the contrast control should be in its usual operating position.
3. Instead of relying on audible sound, an ordinary a-c output

meter such as used in sound receiver alignment may be connected to the audio amplifier output. Then the r-f oscillator is aligned for maximum meter reading with a low setting of the sound volume control.

4. Repeat the process on all channels in which suitable transmissions are available.

R-f oscillator alignment by means of instruments usually is carried out as shown by Fig. 8-11, employing a constant-frequency marker type general to supply the input signal, and an electronic voltmeter as output indicator. The steps are as follows:

1. Use fixed biases from batteries to override the automatic gain control for the tuner and video i-f amplifier, and the automatic volume control if one is included in the sound system.

2. If there is a fine tuning control set it at the approximate center of its range and leave it there during all adjustments.

3. Place the contrast control in its usual operating position.

4. Connect the constant-frequency marker type generator across the two antenna terminals for a balanced line, or between either terminal and chassis ground, or, where the terminals are for an unbalanced line, connect the generator to the antenna terminal and to chassis ground. Use this generator unmodulated.

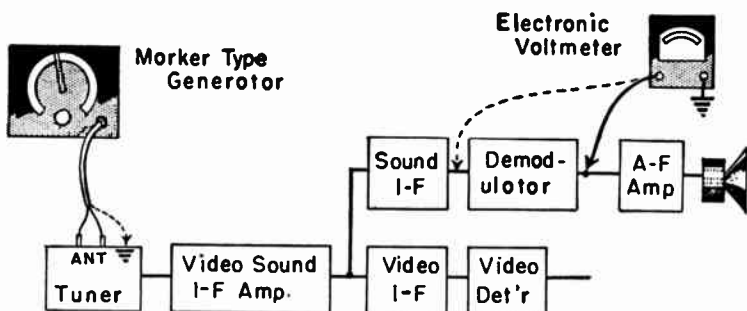

Fig. 8-11.—R-f oscillator alignment by means of a signal put through the sound section.

5. The electronic voltmeter may be connected in any of the ways which were described in connection with alignment instructions for sound systems. These ways include:

a. To the balanced output of the sound demodulator just ahead of the de-emphasis filter. This is in the line carrying demodulated

or a-m signals to the first audio amplifier. Oscillator alignment then will be for zero reading on the voltmeter.

b. To any point of unbalanced output of the sound demodulator, which would be to the center tap between discriminator load resistors, or on the lines connected to the output cathode or plate of a ratio detector. Oscillator alignment then will be for maximum reading on the voltmeter.

c. Across the limiter grid resistor in sound systems which include a limiter tube. Alignment then is for maximum meter reading.

6. Sound system couplers and demodulator transformer should be in reasonably good alignment. If there is any doubt of this, make a check according to methods described in the chapter on sound system alignment.

7. Set the channel selector for the first channel to be aligned. Which channel this is may depend on the electrical design and construction in the tuner, as previously explained. When there can be no effect on other channels of adjustment in any one channel, any convenient order may be followed.

8. Turn on the generator, the voltmeter, and the receiver. Let them warm up for at least 20 minutes before changing any adjustments.

9. Tune the generator precisely to the sound carrier frequency of the channel to be first aligned.

10. Adjust the oscillator inductance or capacitance for the tuned channel to produce either zero reading or maximum reading on the voltmeter, according to where the voltmeter is connected as explained in preceding step 5.

11. Retune the generator to the sound carrier frequency of each other channel for which there is an oscillator adjustment, set the channel selector for the same channel in each case, and adjust the oscillator tuning for that channel to produce the required zero or maximum reading on the meter.

12. After all channels have been aligned, re-check all of them by making necessary changes in channel selector setting and generator tuning.

Instead of using the constant-frequency generator and electronic voltmeter for r-f oscillator alignment it is possible, as in Fig. 8-12, to use the sweep and marker generators and the oscil-

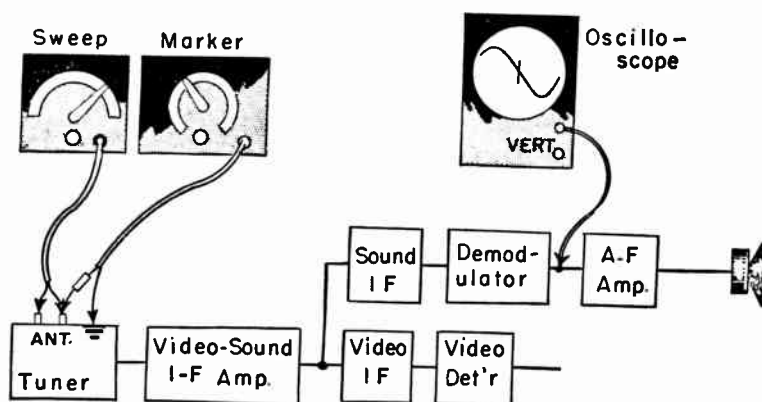

Fig. 8-12.—Oscillator alignment by means of an S-curve taken from the output of the sound demodulator.

loscope. Many of the steps are like those in the preceding method. For preliminaries, follow steps 1, 2 and 3 of that method. Continue as follows:

4. Connect the sweep generator to the antenna terminals or to the antenna and ground terminals of the tuner or receiver. Couple the high side of the marker generator to either antenna terminal, using very loose coupling. Connect the ground of the marker to chassis ground.

5. Connect the oscilloscope to the balanced output of the sound demodulator, which is just ahead of the de-emphasis filter carrying the a-m signal to the audio amplifier.

6 and 7. Same as similarly numbered steps in preceding method.

8. Turn on all the instruments and the receiver. Let them warm up for at least 20 minutes.

9. Set the sweep center frequency to approximately the center frequency of the channel to be first aligned. Use a wide sweep. Tune the marker generator precisely to the sound carrier frequency of this channel. The demodulator S-curve should appear on the scope. If necessary, readjust the sweep center frequency and width to produce a suitable curve.

10. Adjust the oscillator tuning for the channel being aligned to bring the sound marker to the exact center of the S-curve, or to the crossover point if you are using the oscilloscope to produce such a curve.

11. Proceed similarly to align the oscillator on all other channels for which there are adjustments, retuning the sweep and marker generators for each channel. After all channels are aligned, check through them once more.

Oscillator Alignment with Intercarrier Sound.—When the receiver employs intercarrier sound it is impossible to make accurate oscillator alignment through the sound system because there is no narrow band pass centered on the sound intermediate frequency. Fig. 8-13 shows the generally used method for oscillator alignment when there is an intercarrier sound system. Sweep and marker generators provide the input. An oscilloscope is used to produce a trace on which alignment will place in their correct positions either a sound marker, a video marker, or both.

Following are the steps in making this type of oscillator alignment:

1. As for other methods of oscillator alignment, override the automatic gain control with a fixed bias from a battery. If there

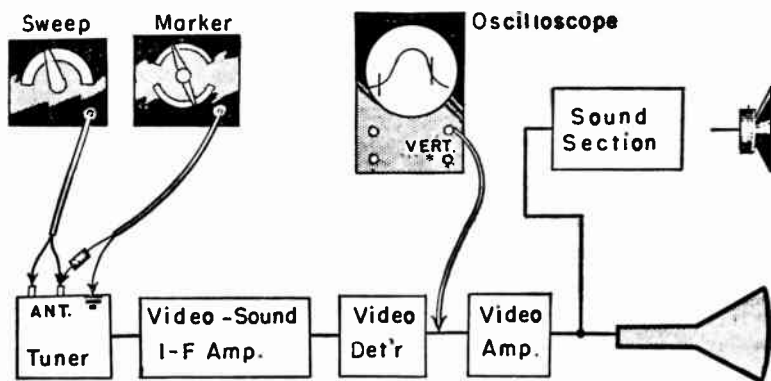

Fig. 8-13.—Oscillator alignment on receiver employing an intercarrier sound system.

is a fine tuning control, set it at the approximate center of its range and leave it there during the entire alignment process. Place the contrast control in its usual operating position.

2. Connect the sweep generator to the antenna terminals or the antenna and ground terminals of the receiver, using an impedance matching pad when the generator does not have suitable output impedance.

3. Loosely couple the marker generator to either antenna terminal of the tuner or receiver, or to the single antenna terminal, and connect the shield side of the generator cable to chassis ground. Use the marker unmodulated.

4. Connect the vertical input of the oscilloscope to the high side of the video detector load resistor, exactly as for observation of the response from a video i-f amplifier. The video i-f amplifier, also the r-f section of the tuner, should be in reasonably good alignment. They should be checked if there is any doubt on this score.

5. Set the channel selector for the first channel to be aligned, this depending on the electrical design and construction of the tuner. If there can be no interaction between oscillator inductors, any order may be followed.

6. Turn on all the instruments and the receiver. Let them warm up for at least 20 minutes before making any adjustments.

7. Set the sweep center frequency to approximately the center of the channel to be first aligned. Use a wide sweep. A typical video i-f response curve should appear on the screen of the oscilloscope. If necessary, readjust the sweep center frequency and width to obtain this trace.

8. Tune the marker generator precisely to the video carrier frequency of the channel being aligned. The video marker should appear in its correct position on the high-frequency side of the trace, this position having been discussed in connection with video i-f alignment. If the marker is not correctly placed, adjust the oscillator tuning to bring it there.

9. Retune the marker generator precisely to the sound carrier frequency of the same channel. The sound marker should appear in its correct position on the trace, according to the discussion of video i-f alignment with intercarrier sound systems. To make the sound marker more clearly visible, the trace may be enlarged by using the oscilloscope gain control, and shifted toward the sound side by using the horizontal centering control. The sound marker will become more apparent when using a very low output from the sweep generator and reducing the marker output until there is no distortion of the trace.

If desired, steps 8 and 9 may be reversed to first check the sound marker and then the video marker.

10. Retune the sweep and marker generators, and set the channel selector, for each other channel on which there are adjustments for the oscillator. Check the sound and video markers on each channel, and align the adjustments when required. When all adjustments have been completed, check the positions of the markers for all channels, whether or not adjustments have been made in all channels.

An approximate oscillator adjustment may be made for channels in which nearby stations are operating by using an electronic voltmeter as the only instrument. The method is as follows:

1. Connect the electronic voltmeter input terminal to the high side of the video detector load resistor.

2. Set the channel selector for the first channel to be aligned. This must be a channel on which a station is furnishing a test pattern, not a picture.

3. Place the contrast control in its usual operating position, or about three-fourths of the way up.

4. Adjust the brightness control to suit the contrast, so that there are no white diagonal streaks on the picture tube screen.

5. Set the fine tuning control to the approximate center of its range and do not alter this control during following steps.

6. Adjust the sound volume control for only moderate loudness.

7. Vary the oscillator tuning slug or other adjustment for this channel in three ways:

a. Until the sound commences to get louder and the picture less bright. Now the actual sound intermediate frequency is being moved up on the gain curve, as at the left in Fig. 8-14, and the actual video intermediate frequency is being moved down. The meter reading will drop.

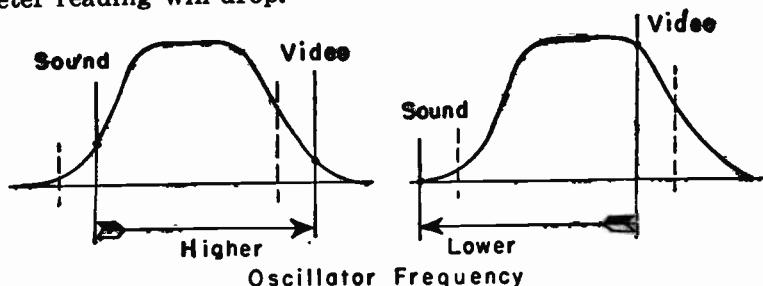

Fig. 8-14.—How sound and video intermediate frequencies are shifted on the gain curve during oscillator alignment.

b. Change the oscillator tuning in the opposite direction until the sound becomes fainter than its original volume and the picture becomes brighter. Now, as at the right in Fig. 8-14, the sound intermediate frequency is moving down and off the toe of the gain curve while the video intermediate frequency is moving up. The meter reading will increase. Beyond a certain point of adjustment the picture will become no brighter and the meter reading will cease rising. The video intermediate frequency then is on the top of the gain curve.

c. Adjust the oscillator tuning to bring the meter reading to about half or slightly more than half of its former maximum. The picture should be good, but not of maximum brightness. It should be possible to make the sound of any reasonable intensity by manipulation of the sound volume control.

8. Repeat these tests and adjustments on other channels in which stations are operating.

An oscilloscope may be connected to the video detector load resistor instead of using the electronic voltmeter. With the internal sweep of the scope set for 30 cycles per second the trace



Fig. 8-15.—Height of the picture and sync signal will vary during oscillator adjustment.

will show picture signals and vertical blanking as in Fig. 8-15. The height of the trace, dimension E , will increase as the video intermediate frequency is moved up on the gain curve by adjustment of oscillator tuning.

Overall Check.—After any alignment has been made in the r-f couplers, the oscillator, or the video i-f amplifier, there should be a final check with signal generator input to the antenna terminals of the tuner or receiver and with output observed at the video detector. As with other alignment procedures, the automatic gain control should be overridden with a fixed bias from a battery, a fine tuning control should be kept at the approximate center of its range, and the contrast control should be in its usual operating position.

The sweep generator should be connected to the antenna terminals, and used with a wide sweep to cover each channel as checked. The marker generator is very loosely coupled to one of the antenna terminals. The marker is used without modulation for checking the video and sound intermediate frequencies on the response curve, but may be temporarily modulated from time to time while checking relative sound volumes at the loud speaker. A-m sound will come through the f-m sound section when the

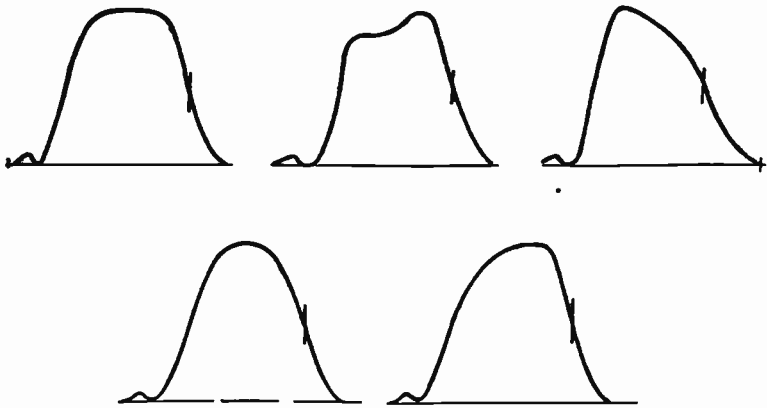

Fig. 8-16.—Overall responses for various channels in a single receiver.

signal is applied in this manner. The oscilloscope is connected to the high side of the video detector load resistor. The trace will be the video i-f response and will show dips which are due to any traps in the r-f and video i-f sections.

Every channel should be checked, even though there are no r-f or oscillator adjustments for some of them. With the marker tuned precisely to the video carrier frequency for the channel, the pip should show at a point 40 to 50 per cent down on the high frequency slope of the response. With the marker tuned to the sound carrier frequency for the channel, the pip should show on the low-frequency end of the response, or should be visible on either side of any dip caused by traps for accompanying sound.

The response traces will not be of exactly the same shape for all channels. The response of the video i-f amplifier remains unchanged, but when the signal applied to this amplifier comes through the tuner, all the variations of r-f responses on different

channels are magnified or subdued by gain in the video i-f amplifier. Overall responses of such shapes as shown in Fig. 8-16 may be expected on different channels with the same receiver. No matter what the shape of the overall response, the video i-f marker should be about half way between the peak and zero and the sound i-f marker should be on the opposite toe of the curve as required by the type of sound system used.

Oscillator alignment adjustments may have to be retouched on some channels to bring markers where they belong for those

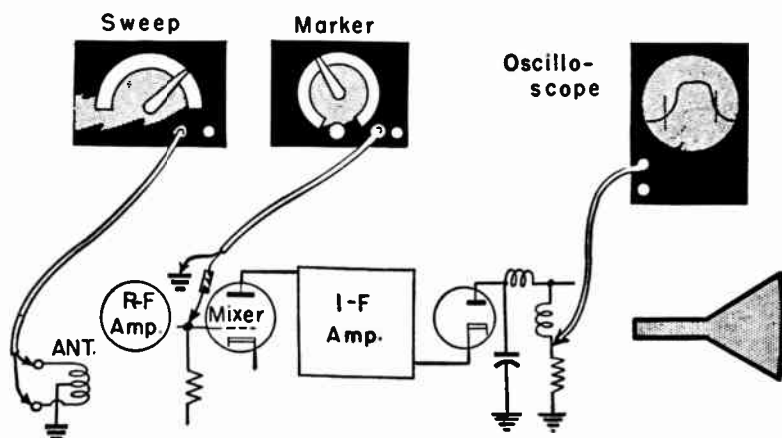

Fig. 8-17.—Introducing marker frequencies at the mixer tube and sweep frequencies at the antenna terminals.

channels or on other channels affected by a single adjustment. R-f adjustments for individual channels may need similar re-touching. If marker positions are incorrect on all channels, and always in the same direction, the indication is that one or more overall adjustments need attention or that the video i-f amplifier is aligned for the wrong video and sound frequencies.

If you have no marker generator which will furnish the high frequencies for video and sound carriers it is possible to carry out the overall check with a low-frequency marker generator coupled to the mixer control grid as in Fig. 8-17. This marker is tuned to the video intermediate frequency and then to the sound intermediate frequency as each channel is tested. The sweep generator must remain connected to the antenna terminals

in order that the r-f stages may have their effect on the overall response.

The final step in every overall checkup is observation on the picture tube of a regularly transmitted picture or, much to be preferred, a transmitted test pattern. If possible, observe test patterns on more than one station. Local conditions may prevent good reception in some channels and not in others. No matter how correct the adjustments may seem when checked with instruments, if a test pattern cannot be received with good definition and satisfactory shading the adjustments actually are incorrect and must be gone over again.

Chapter 9

VIDEO DETECTOR AND AMPLIFIER

The video detector most often consists of one section of a twin diode tube, although a number of receivers employ a crystal diode for this purpose. The diode detector, of either kind, acts on the amplitude-modulated video signal just as the diode detector in a standard broadcast sound receiver acts on the amplitude-modulated sound signal. The detector demodulates the video intermediate frequency coming from the last i-f coupler and delivers the envelope which consists of sync pulses and of video frequencies for the picture. This envelope is the composite television signal which, as explained earlier, is applied to the

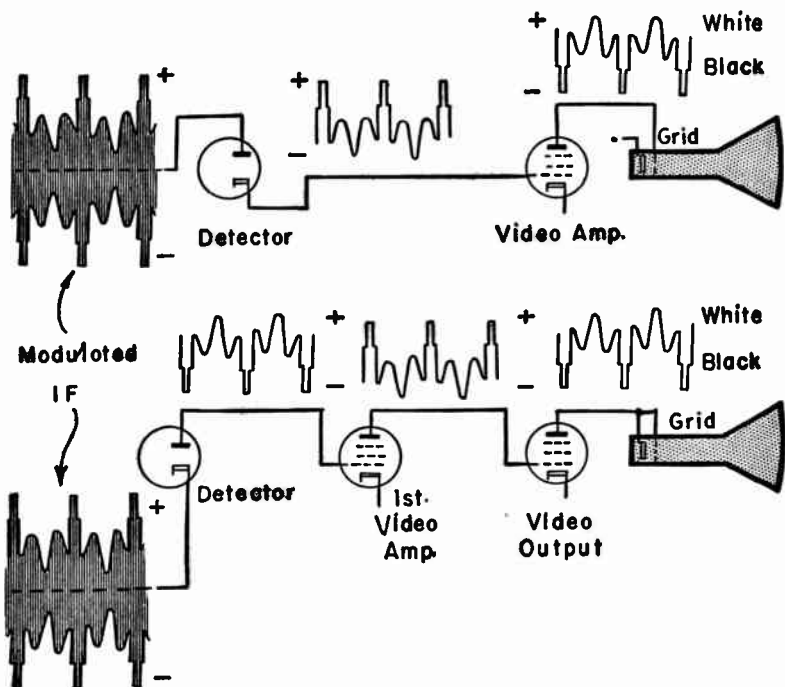

Fig. 9-1.—Signal polarities between detector and picture tube when input is to the grid of the picture tube.

picture tube grid-cathode circuit and also to the sync section. Suitable biasing of the picture tube cuts off the sync pulses and leaves only the picture elements of the signal. In the sync section the operating voltages and biases are such as to cut off the picture elements and leave only the sync pulses.

Signal Polarity.—Fig. 9-1 shows a composite signal applied to the control grid of the picture tube. For light tones in the picture the grid must become more positive or less negative. This increases beam current and brilliancy on the screen. Consequently, in the signal reaching the picture tube grid, the picture elements must be positive and the sync pulses negative. Between the picture tube and video detector must be at least one video amplifier. Signal polarities are inverted in passing through any amplifier. Then the signal at the control grid of the video amplifier must have the picture elements negative and the sync pulses positive in order that these two may be right side up at the picture tube. This inverted signal is shown on the line to the control grid of the video amplifier.

Now look at the left-hand side of the upper diagram in Fig. 9-1. There we have the modulated intermediate frequency with its upper and lower envelopes, one of which is to be recovered in the detector output. If this intermediate frequency is applied to the plate of the detector the upper envelope will make the plate positive with reference to the cathode. Then this envelope will cause conduction in the detector, and in the output will appear the upper or positive envelope. This is the envelope required when there is only one video amplifier and when the signal is applied to the picture tube grid.

The lower diagram of Fig. 9-1 shows what happens with two video amplifiers when the signal is applied to the control grid of the picture tube. There must be one extra inversion of signal polarity. To obtain this extra inversion we must recover the lower envelope of the i-f signal. This negative envelope is recovered by applying the i-f signal to the detector cathode. The negative side of the i-f signal makes the cathode negative with reference to the plate, and there is conduction on this side.

Fig. 9-2 shows the composite signal applied to the cathode of the picture tube. In order that white portions of the signal may increase beam current and brilliancy on the screen these white

portions must make the cathode more negative, for this has the same effect as making the grid more positive or less negative. Then the signal must reach the cathode with the white level negative and the black level and sync pulses positive.

If there is but one video amplifier the signal needs inversion only once, which means that in the detector output the picture elements must be positive and the sync pulses negative. We learned from the preceding diagram that such a detector output

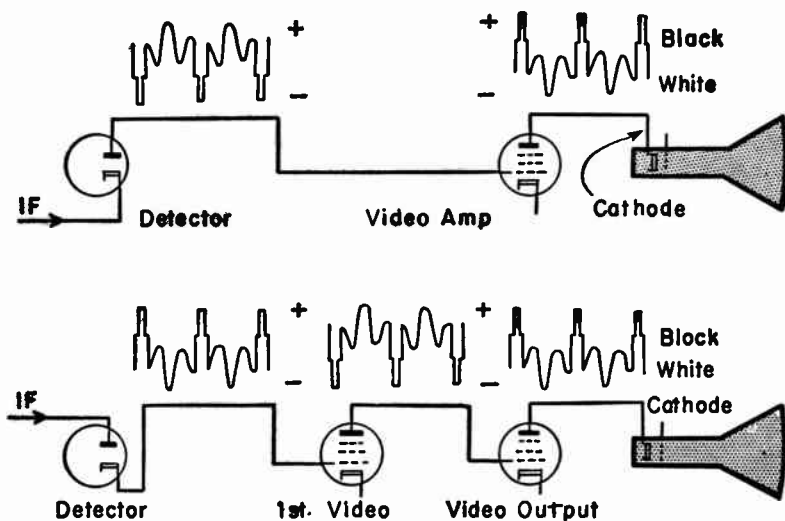

Fig. 9-2.—Signal polarities when input is to the cathode of the picture tube.

is secured by applying the i-f signal to the detector cathode, as in the upper diagram of Fig. 9-2.

With two video amplifiers, and signal input to the picture tube cathode, there is required one more inversion, which is secured by applying the i-f signal to the detector plate. This is shown by the lower diagram.

To determine signal polarities at various points between detector and picture tube consider first whether the input is to grid or cathode of the picture tube. This tells whether the white level must be negative or positive at this tube. Then go back through the video amplifiers, with each amplifier inverting the signal. When reaching the detector output the upper or positive side of

the envelope will be recovered if this signal is applied to the detector plate, which must be positive in order to have conduction. The lower or negative side of the envelope will be recovered if the i-f signal is applied to the detector cathode, which must be negative to have conduction.

Detector Circuits.—Fig. 9-3 shows detector circuits quite generally used where the i-f input is to the detector plate and output from the cathode. Inductors L_a and L_b are series and shunt peaking coils which help maintain good response at the higher video frequencies. Sometimes only one of these inductors is used. Resistor R_o is the detector load resistor, usually of some value between 3,000 and 8,000 ohms. This low resistance is necessary because of the shunting effects of tube capacitances whose low reactance at the high frequencies must be compensated for by the low load resistance.

In the left-hand diagram there is direct conductive connection from detector cathode to video amplifier control grid. Negative bias for the amplifier is applied at the bottom of the detector load resistor.

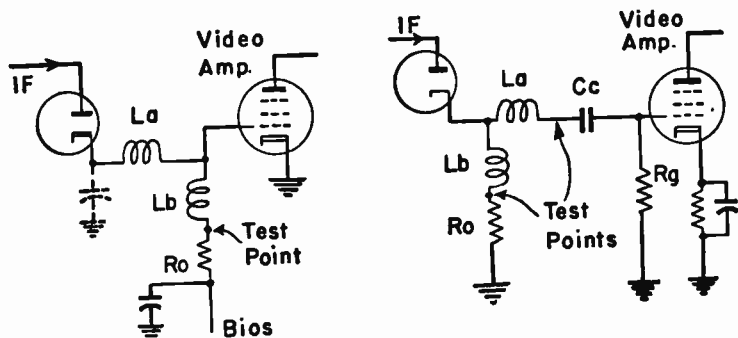

Fig. 9-3.—Video detector circuits in which i-f input is to the plate of the diode.

tive bias for the amplifier is applied at the bottom of the detector load resistor. In the right-hand diagram there is a coupling and d-c blocking capacitor C_c between detector and amplifier grid. The amplifier is biased by grid rectification in this capacitor and grid resistor R_g . Additional cathode biasing may or may not be used.

Test points indicated in these circuits are those to which may be connected either an oscilloscope vertical input or the high side of the input to an electronic voltmeter. Waveforms on an oscil-

oscope will be those of the demodulated composite signal. Voltage on a meter will show average strength of the demodulated signal, which here is a d-c potential varying at video frequencies.

Fig. 9-4 shows a typical detector circuit used where i-f input is to detector cathode and output from the plate. Inductors L_a and L_b are series and shunt peaking coils, R_o is the detector load resistor, C_c is a coupling and d-c blocking capacitor, and C_b is a bypass capacitor for intermediate frequency, which is higher than any video frequency. Since the detector plate now

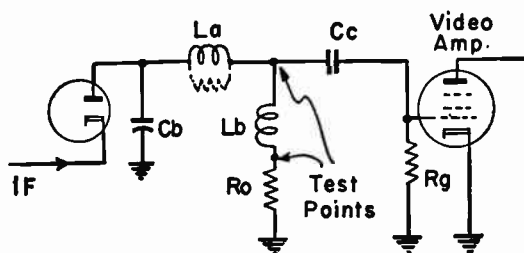

Fig. 9-4.—A detector circuit with i-f input to the cathode of the diode.

is positive it is not conductively connected to the video amplifier control grid. The amplifier is biased by grid rectification action of C_c and resistor R_g . Test points shown on the load connection are for the oscilloscope or electronic voltmeter.

Features illustrated in these detector circuits may be combined and modified in various ways without affecting general principles of operation and testing. For example, either or both peaking coils may have paralleled resistors, as shown on one of them in Fig. 9-4. The load connection may either precede or follow the series peaking coil. Resistor R_g may be a potentiometer used for contrast control much as a potentiometer is used on the first a-f grid for volume control in sound receivers.

Crystal Detectors.—The 1N34 crystal diode used as a video detector, and at some other places where rectification is needed, is $7/32$ inch in diameter, $3/4$ inch long, and has tinned copper pigtails $1\frac{1}{2}$ inches long on each end. One end is marked positive (+) to indicate the anode, which corresponds to the plate of the diode tube. The other end is marked negative (—) to indicate the cathode, which corresponds to the cathode of a tube so far as conduction is concerned.

The crystal diode is used in detector circuits similar to circuits for tube diodes. Polarities of the signal in the detector output, as shown by Fig. 9-5, correspond to outputs from tube diodes with respect to cathode and to anode or plate. With the i-f input to the

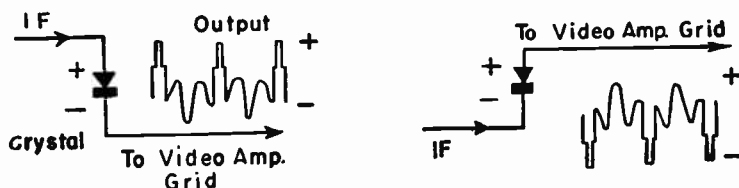

Fig. 9-5.—Signal polarities in the output of a crystal diode detector.

anode (plate) of the crystal, as in the left-hand diagram, picture elements are negative and sync pulses positive in the output. This output polarity is the same as in the upper diagram of Fig. 9-1 and the lower diagram of Fig. 9-2. When i-f input is to the crystal cathode, as at the right in Fig. 9-5, picture elements are positive and sync pulses negative in the output. This polarity is the same as in the lower diagram of Fig. 9-1 and the upper diagram of Fig. 9-2.

Crystal diodes usually are mounted by soldering their pigtailed to the supports in the circuit. Do not heat the pigtailed more than necessary for a good joint, and never solder closer than $\frac{1}{4}$ inch to the crystal enclosure. The condition of a crystal diode may be checked with an ohmmeter. With the negative of the ohmmeter to the negative end of the crystal, and positive to positive, the "forward resistance" should be a few hundred ohms. With the meter leads reversed on the crystal the "back resistance" will measure nearly to infinity on a low reading ohmmeter and on other types should be at least 125 times the forward resistance, and preferably more than this.

Waveforms.—At every point in the receiver beyond the video detector we may use the oscilloscope to observe signal waveforms instead of the frequency responses observed ahead of the detector. No signal generator is needed to produce these waveforms, nor could any commonly available generator be so used. The signals are those transmitted by television stations. Either a program picture or a test pattern may be used. When employing a picture in which there is motion, the portions of the traces

in between sync pulses weave and twist continually. These portions of the signal remain steady when there is a test pattern. Sync pulses and blanking intervals are the same for pictures and for test patterns.

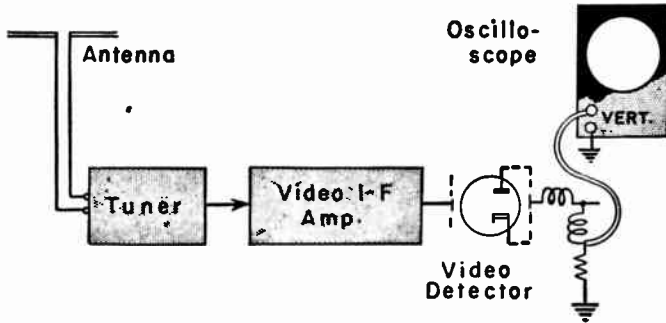

Fig. 9-6.—Connections for observing the signal waveform at the output of a video detector.

The first point of observation usually is at the output of the video detector, as shown by Fig. 9-6. Proceed in this manner:

1. Connect the vertical input of the oscilloscope to the video detector load at any of the points shown in Figs. 9-3 and 9-4.
2. Bring in a picture or test pattern on any channel. The picture or pattern may be watched on the picture tube screen while traces are watched on the oscilloscope screen. Keep the contrast control as for normal reception.

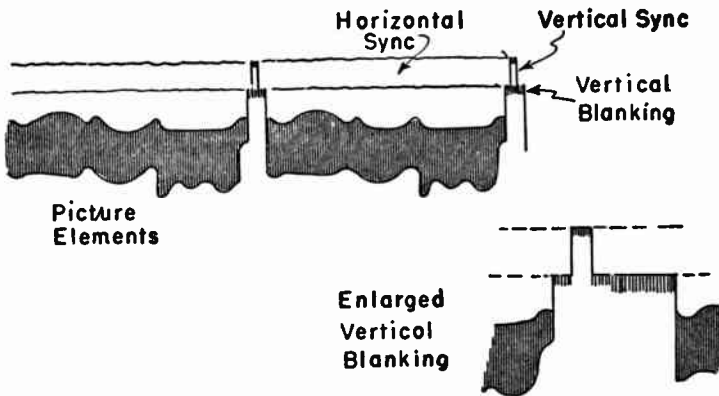

Fig. 9-7.—Signal observed between video detector output and picture tube input with oscilloscope synchronized for 30 cycles per second.

3. To observe the signal for two fields or one complete frame synchronize the internal sweep of the scope at 30 cycles per second. If sync pulses are positive in the detector output the trace will be of the general nature shown by Fig. 9-7. The vertical blanking intervals and vertical sync pulses should be plainly apparent, with picture elements indicated by an outlined glow whose form depends on the shadings or content of the picture or pattern. If the horizontal gain control of the scope is used to enlarge one of the blanking intervals, and the horizontal centering used to keep this interval on the screen, the trace will be of the general form shown at the lower right. Equalizing pulses will be apparent before and after the vertical sync pulse, with the remainder of the blanking interval filled with horizontal sync pulses. Since we are familiar with all these features of the composite signal it is easy to note whether they are being correctly reproduced by the video detector and circuits preceding it.

4. To observe the signal for two lines synchronize the internal sweep of the scope for 7,875 cycles per second, which is one-half the line frequency of 15,750 cycles per second. Of course, the way to synchronize for this exact frequency is to set the timing somewhere around 8,000 cycles, then adjust the synchronizing control to get a steady trace. This trace should be of the general nature illustrated by Fig. 9-8 if the sync pulses are positive in the detector output. How well defined are the corners of the pulses and how nearly vertical are the sides will depend largely on the ability of the oscilloscope amplifier to handle high frequencies. It should be possible to distinguish quite clearly the horizontal sync pulses, the pedestal at the black level, and the horizontal blanking intervals.

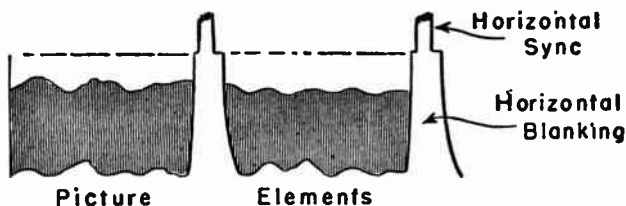

Fig. 9-8.—Signal between video detector output and picture tube input with oscilloscope synchronized for 7,875 cycles per second.

If sync pulses are negative in the detector output the traces of Figs. 9-7 and 9-8 will be inverted. They will be inverted also by an extra vertical amplifying stage in the scope. With the scope beam sweeping from left to right, as nearly always is the case, earlier times are at the left and later times at the right in all traces.

To observe the output of the video amplifier which follows the detector, remove the vertical input of the oscilloscope from the detector load resistor and connect it to the load resistor in the amplifier plate circuit. The signal will be inverted from its polarity at the detector output. If the amplifier output should be taken from its cathode rather than the plate, as where there are remotely located picture tubes, the polarity of the cathode output will be the same as at the detector output.

The output from an amplifier plate should be much stronger than from the preceding detector and much stronger than at the input to the control grid of the amplifier. To observe whether there really is gain in an amplifier, and to check its approximate value, first connect the scope to the amplifier input circuit and use the vertical gain of the scope to provide a trace of small but easily measured height. This will require using the cross ruled graph scale in front of the screen. Then transfer the scope lead to the amplifier output, or plate load, and note how many times higher is this trace than the trace at the input connection. This number of times is the approximate gain in the amplifier.

With reference to measurements of gain or increase of voltage, unless the signal is that for a test pattern in which there are no changing lights and shadows, there is no use of measuring the overall height of the trace. The overall height will become greater with a light toned picture, and less with one of dark tone. Measurement should be made of the height of sync pulses, from the black level to the tips of the pulses. This pulse height is proportional to signal strength, and is not affected by the tone of the picture. Gain measurements may be easier to make if the scope is connected first to the amplifier output and the trace adjusted for the greatest height which can be measured. Then the scope is transferred to the input and, without changing the vertical gain control of the scope, the height of the input trace is compared with that on the output.

Waveforms may be observed by connecting the vertical input of the oscilloscope to the cathode of an amplifier instead of into the grid circuit or plate circuit. The polarity of the waveform from the cathode will be the same as from the control grid circuit, since there is no inversion between grid and cathode. The cathode waveform will be inverted with reference to the waveform from the plate of the same tube. Signal amplitude or voltage measured at the cathode will be slightly less than when measured at the control grid.

The amplitude or voltage of waveforms from the video amplifier tubes, and at the grid-cathode input to the picture tube, will be affected by setting of the contrast control when measurement is made beyond the location of this control. For example, were a contrast control to act only on the first video amplifier tube, variation of this control would have no effect on the amplitude of a trace taken from the detector output or at the control grid of the amplifier. But this control would have very great effect on amplitude of a signal taken from the amplifier plate circuit or at any point from there on to the picture tube input. Were a contrast control to act on the video i-f amplifier stages, manipulation of the control would vary the amplitude of a waveform taken from the detector output or from any point in the video amplifier. The behavior and effects of contrast controls are easily observed by working in the manner just explained.

Video Amplifier.—The video amplifier consists of from one to three resistance-capacitance coupled stages with high-frequency compensation consisting of series and shunt peaking

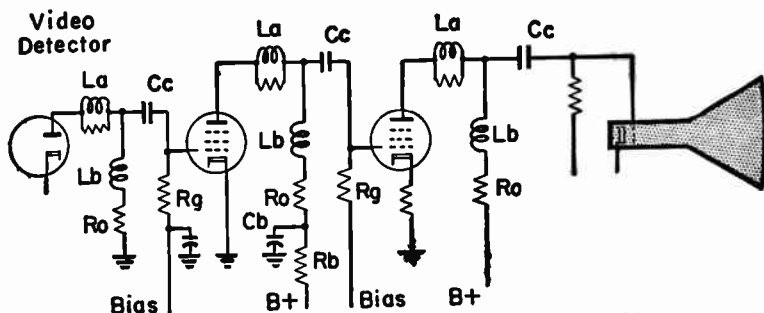

Fig. 9-9.—Connections in a typical two-stage video amplifier.

coils and suitable load resistances. A typical circuit diagram is shown by Fig. 9-9. In the interstage couplings are series peaking coils L_a , shunt peaking coils L_b , and load resistors R_o for maintaining good response through the higher video frequencies. Low-frequency compensation is provided by large capacitances in the coupling capacitors C_c , and sometimes by using values of decoupling capacitors and resistors, as at C_b and R_b , suited to the values of grid resistance at R_g .

Everything about the video amplifier is highly critical in problems of original design. The effective band pass must extend from around 60 cycles per second to a high limit of 4 mc or slightly higher for picture tubes of 10-inch and greater diameters. Smaller tubes allow using narrower band widths.

Alignment of Trap for Intercarrier Beat.—In receivers which do not employ the intercarrier sound system there may be, somewhere in the video amplifier, a trap for the intercarrier beat frequency of 4.5 mc. Fig. 9-10 shows such a trap in series with the plate lead of the first video amplifier, in the coupling between this amplifier and the video output tube. Alignment is carried out as follows:

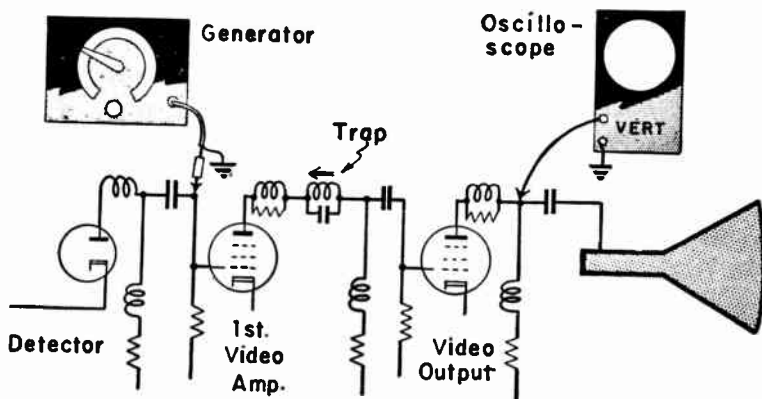

Fig. 9-10.—Alignment of trap for intercarrier beat frequency.

1. Loosely couple a constant-frequency, marker type, signal generator to the control grid of the tube preceding the trap. Tune the generator precisely to 4.5 mc. Use tone modulation.
2. Set the channel selector for a channel in which there is no

nearby transmission. Adjust the contrast control to the highest point which would ordinarily be used for reception.

3. Connect the vertical input of the oscilloscope, through the detector probe, to the plate of the tube which follows the trap, or anywhere between the plate of this tube and the input to the grid-cathode circuit of the picture tube. Synchronize the internal sweep of the scope to the modulation frequency of the generator, thus producing a trace whose height will vary with signal strength.

4. Adjust the trap for minimum height of trace on the scope. Increase the generator output as adjustment proceeds.

An electronic voltmeter with a high-frequency detector probe may be used instead of the oscilloscope. The trap then is adjusted for minimum reading on the meter with the generator output well up.

Chapter 10

PICTURE TUBE INPUT CIRCUITS

Fig. 10-1 shows one of the simplest control grid-cathode circuits for a picture tube. The plate of the last video amplifier is conductively connected, with no coupling and blocking capacitor, to the control grid of the picture tube. Consequently, these two elements in the two tubes must be at the same potential except for the slight drop in the peaking coil. To illustrate what happens we shall assume this potential to be 100 volts, also that the B+ supply potential for the circuit is 250 volts.

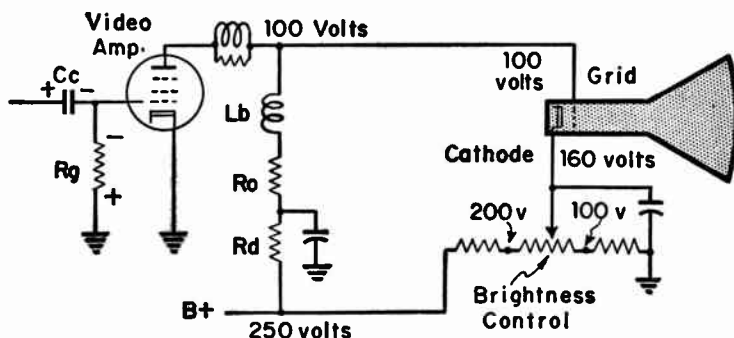

Fig. 10-1.—Signal applied to picture tube grid through a direct conductive connection.

The cathode of the picture tube is connected to the slider of a potentiometer which forms one of a series of resistors between B+ and ground. This potentiometer is the brightness control or the brilliance control used by the operator. By moving the slider, the cathode potential may be made anything between 200 volts and 100 volts. It is shown as being set for 160 volts, positive with reference to ground. Then the cathode is 60 volts more positive than the grid of the picture tube, which is equivalent to having the grid 60 volts more negative than the cathode, and we have a 60-volts negative grid bias. Movement of the brightness control slider will make this bias anything between zero and 100 volts

negative so far as the grid is concerned. This variation of grid bias regulates the average value of beam current and the average brightness of pictures on the screen.

The same general principle may be employed when the video signal is applied to the picture tube cathode, as shown by Fig. 10-2. Now we have 160 volts positive on the video amplifier plate and the picture tube cathode. Resistors in series with the brightness control potentiometer are of such values that movement of the slider will make the grid potential anything between 160

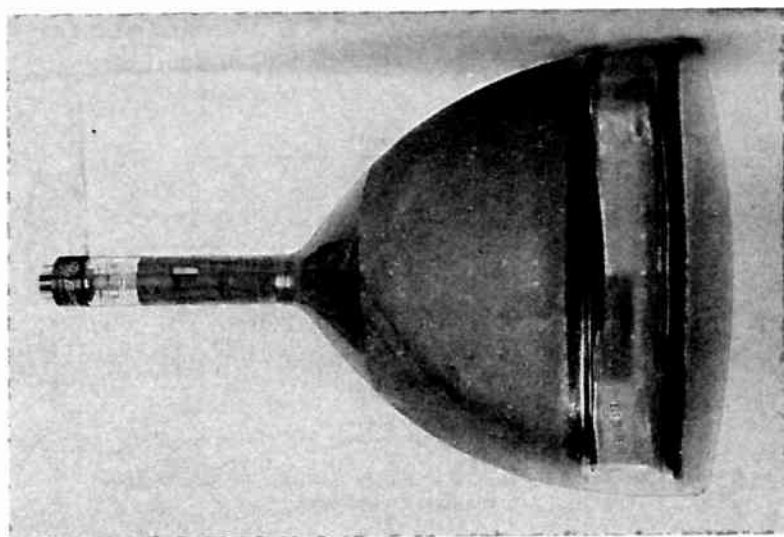

Fig. 10-1A.—An all-glass rectangular picture tube.

and 60 volts. The potential on the grid is shown as 100 volts in the diagram. Although both grid and cathode of the picture tube still are highly positive with reference to ground, the cathode is 60 volts more positive than the grid. This is equivalent to making the grid 60 volts negative with reference to the cathode, and again we have a 60-volt negative grid bias.

Note that moving the control slider of Fig. 10-1 to the right reduces the negative grid bias and makes a brighter picture. This movement brings the grid and cathode voltages more nearly together in value. To bring the two voltages more nearly together and thus increase brightness with the control of Fig. 10-2 the

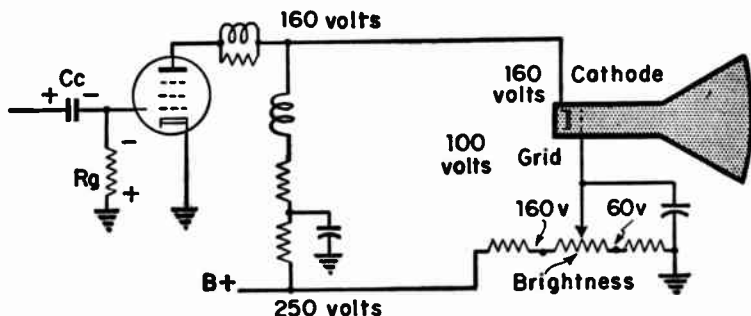

Fig. 10-2.—Signal applied to picture tube cathode through a conductive circuit.

slider must be moved toward the left. This general principle of varying the potential of either the grid or cathode in the picture tube is employed for brightness control in the majority of receivers. The brightness control is a means for making the grid bias of the picture tube more or less negative.

Some relations between grid bias and composite signal are shown by Fig. 10-3. The curve shows relations between picture

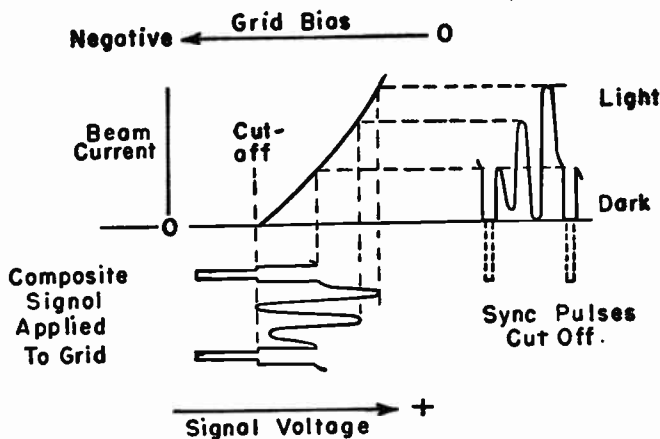

Fig. 10-3.—A composite signal applied to the beam-current grid-voltage characteristic of a picture tube.

tube beam current and grid voltage just as a similar curve might show relations between plate current and grid voltage in an amplifier tube. The composite signal applied to the picture tube

grid is shown below the curve, and at the right is shown resulting beam current whose variations cause lights and shadows on the screen.

The composite signal, as delivered in the circuits of Figs. 10-1 and 10-2, becomes more positive for light portions of the picture, and less positive for dark portions and for sync pulses. To have correct reproduction, the grid bias must be such as brings the black level of the signal down to the point of beam current cutoff, because cutoff means blackness on the screen. This is the bias which must be produced by correct adjustment of the brightness control.

Before considering what happens with misadjustment of the brightness control we shall look at the grid-cathode input circuit of the picture tube in Fig. 10-4. Here there is a coupling and blocking capacitor C_c between the plate of the last video amplifier and the cathode of the picture tube. Consequently, the com-

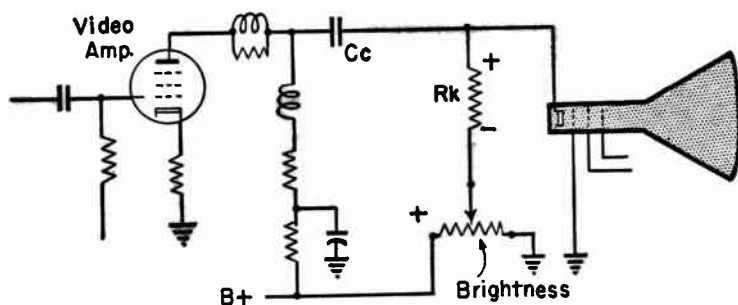

Fig. 10-4.—Signal applied to picture tube cathode through a coupling capacitor.

posite signal reaching the picture tube cathode is not a varying direct voltage but is an alternating voltage varying at video and sync frequencies above and below the a-c zero value of the signal. This is only one of the many kinds of circuits with which an a-c signal is applied to the picture tube.

When the signal applied to the picture tube is an a-c voltage we have the condition shown by Fig. 10-5. Whatever the grid bias voltage may be, the zero value of the a-c signal will lie on this bias voltage. Signal voltages on the positive side of zero make the picture tube grid less negative than the bias voltage, while signal voltages on the negative side make the grid more

negative. The same thing would happen with any a-c signal applied to an amplifier tube.

Now the grid bias must be made of a value which brings the black level of the signal at the grid voltage for beam current cutoff. This is the bias provided by correct adjustment of the brightness control. Then, on the screen of the picture tube, there will be reproduced all the lights and shadows of the picture, clear down to the black level, but the sync pulses will be

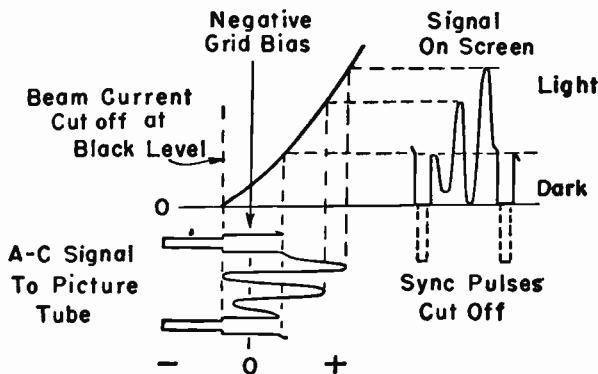

Fig. 10-5.—How the a-c composite signal is applied to the characteristic of the picture tube to cut off sync pulses.

cut off and will not affect the picture. We have the same result in Fig. 10-3, but there the grid is biased beyond beam cutoff to accommodate the d-c signal.

Supposing our signal becomes weaker, what will happen? The answer is shown at the left in Fig. 10-6. The signal is weaker because the sync pulses are shorter. Remember, the signal strength is proportional to the height or the sync pulses regardless of whether the picture tones are light or dark. The average or zero value of the signal still will ride at the grid bias voltage, which has not been changed from its value in Fig. 10-5. But now the lesser overall voltage swing of the weak signal brings the black level above the beam current cutoff voltage. As a result, only parts of the sync pulses are cut off and the remaining parts affect beam current and affect the picture reproduced on the screen.

There are two possible ways of making correction for the weaker signal. First, the brightness control may be adjusted to make the grid bias more negative. This will move the input signal to the left, since it always rides at the bias voltage, and will bring the black level over to the point of beam current cut-

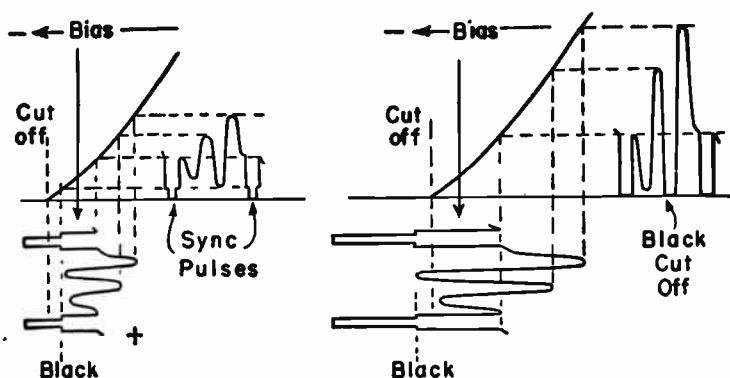

Fig. 10-6.—Effects of weaker and stronger signals when the picture tube grid bias is not altered.

off. Second, the contrast control might be adjusted to make the signal stronger. This would increase the signal amplitude. Bringing the amplitude up to the value shown by Fig. 10-5 would bring the black level over to the point of beam current cutoff, and the sync pulses would be removed from the picture. Unless the controls are readjusted to handle the weaker signal, the portions of the picture which should be black will be gray, the lighter portions will be too light, and the sync pulses will cause white diagonal lines across the picture. The lines due to vertical sync pulses will be clearly visible.

Should the signal become stronger the results will be as shown at the right in Fig. 10-6. The signal is stronger because the sync pulses are longer. The greater swing of the stronger signal brings the black level beyond the point of beam current cutoff with the bias unchanged from its original value in Fig. 10-5. Now we have cutoff not only of the complete sync pulses but also of the blackest portions of the video signal. Portions of the picture which should be dark gray become black, because they come closer to beam current cutoff. Portions which should be light become too dark.

There are two ways of making correction for the stronger signal. First, we may make the grid bias less negative by manipulation of the brightness control. This will move the signal to the right and bring the black level to the point of beam current cutoff. Second, we may reduce the contrast control to make the signal weaker at the picture tube input. This will bring the signal back to the value represented in Fig. 10-5 and restore the black level to the cutoff point.

To maintain correct relations of all picture tones from darkest to lightest, the black level of the applied signal must be held at the voltage for beam current cutoff. When there are changes of signal strength this will require simultaneous adjustment of brightness control and contrast control. These two controls must be advanced (more brightness or more contrast or both) for stronger signals. They must be retarded (less brightness or less contrast or both) for weaker signals. A satisfactory setting usually is made by turning the brightness control just below the point at which diagonal white lines disappear, this for any given setting of the contrast control. The contrast control must be set to best accommodate the strength of signal, high for weak signals, and relatively low for strong signals. Every readjustment of the contrast control calls for an accompanying readjustment of the brightness control (which is the bias control) in order to avoid conditions shown by Fig. 10-6.

D-c Component of Signal.—We have seen what happens with change of strength of the composite signal applied to the picture tube. Now let's see what happens when there is a change of average tone in the picture. At the left in Fig. 10-7 we have a signal whose strength is the same as in Fig. 10-5. We know the signal strength is unchanged because the sync pulses are of equal lengths in both diagrams. But now we have a picture which is of dark tone instead of the medium tone in earlier diagrams.

We shall assume that the grid bias (brightness control) is unchanged, it is of equal values in Figs. 10-5 and 10-7. With the dark picture there is less overall swing of signal voltage above and below zero. But, as always, the average or zero value of the signal rides on the bias voltage. The result is to bring portions of the sync pulses well above the voltage for beam current cutoff, also to bring the positive side of the signal higher than it

should be on the curve. The picture which should be of dark tone becomes of a tone which is too light on the picture tube screen. This is plainly evident from the fact that even the sync pulses, which should always be blacked out, have come up into the reproduced portion of the picture.

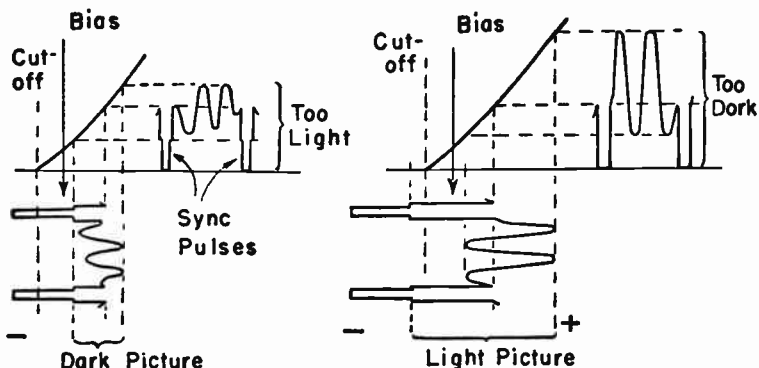

Fig. 10-7.—Effects of darker pictures (left) and of lighter pictures (right) when the picture tube grid bias is not altered.

The effect of a signal for a light toned picture is shown at the right in Fig. 10-7. The average or zero value of the a-c signal still rides on the bias voltage point. But the greater swing of the signal carries its black level beyond the cutoff voltage for beam current. At the same time the lightest portions of the signal are thrown farther to the left than as though the black level were at the cutoff point. This brings these lightest portions farther down than they should be on the beam current curve. The result is to make the supposedly light toned picture become too dark.

With dark pictures made too light and light ones made too dark the effect is to destroy correct contrast and to bring all pictures toward a rather lifeless gray. Correct contrast could be maintained by continual readjustment of the brightness control to keep the black level of the signal at the point of beam current cutoff. Obviously, no one could operate the brightness control to anticipate every change in picture tone. Correction would not be needed were it possible to apply the output of the video detector directly to the picture tube grid-cathode circuit. The reason is that, in the detector output we have a d-c signal wherein

the black level remains at a voltage determined by the strength of signal from the video i-f amplifier. That is, we would have in the detector output signal a steady "d-c component" maintaining a constant black level. The detector output is not strong enough for application to the picture tube, and one or more video amplifiers must be used.

Video amplifiers are resistance-capacitance coupled. When the composite signal goes through a coupling capacitor it becomes an a-c signal, and the d-c component is lost. Then we would have the effects shown by Fig. 10-7 unless some kind of correction were applied. This correction must be automatically applied by changes of picture tone in the signal, and it must act to change the grid bias of the picture tube as required by every change of picture tone. The correction is called *d-c restoration* or *d-c reinsertion*.

D-c Restoration at Video Amplifier.—Back in Figs. 10-1 and 10-2 there is direct conductive connection between amplifier plate and picture tube grid or cathode. If the black level voltage is constant in the amplifier plate circuit it will be constant at the picture tube grid or cathode, so there is no loss of d-c component in this part of the circuit. The d-c component is lost when the signal goes through coupling capacitor C_c in the amplifier grid circuit, and it must be restored in this grid circuit.

D-c restoration is effected by grid leak-resistor biasing of the amplifier. Signals coming to the grid circuit are rectified by the control grid and cathode, acting like a diode plate and cathode. The rectified signals charge capacitor C_c in the polarity shown in Figs. 10-1 and 10-2. Electrons of this charge leak away to ground through resistor R_g , making the upper or grid end of this resistor negative with reference to the lower or grounded end. Since the negative end of R_g is connected to the control grid, the grid is made negative with reference to the cathode, which is connected through ground to the lower or positive end of R_g .

The greater the amplitude of the applied composite signal the greater will be the charge held on the grid capacitor and the more negative will become the bias on the amplifier tube. A signal for light tones has greater amplitude than one for dark tones, so light toned signals make the amplifier grid more negative while dark toned signals allow it to become less negative.

Amplifier output is reduced on light signals and allowed to increase on dark signals. Thus the tone of the signal, so far as lights and darks are concerned, is not allowed to affect the signal in the plate circuit. The plate circuit signal is applied directly to the picture tube.

Restoration at Picture Tube Cathode.—In Fig. 10-4 there is a coupling capacitor C_c between the plate of the video amplifier and the cathode of the picture tube. The d-c component will be lost in this capacitor, and must be restored in circuits beyond the capacitor. Restoration is effected by action of resistor R_k which is connected between the picture tube cathode and ground by way of the brightness control. All direct electron flow to the cathode must pass through this resistor. The flow is in such direction as to make the cathode end of R_k positive with reference to the end which is connected through ground to the control grid.

The greater amplitude of a light toned signal increases the average beam current, increases electron flow in R_k , and increases the voltage across this resistor. Then the cathode becomes more positive, which is equivalent to making the grid more negative. A dark toned picture has the opposite effects on grid bias. Thus there is a self-biasing action tending to maintain an instantaneous average bias suited to the picture. This may be called automatic brightness control rather than d-c restoration.

Restoration with a Diode.—Fig. 10-8 shows one method of d-c restoration utilizing a diode tube and biasing resistor connected

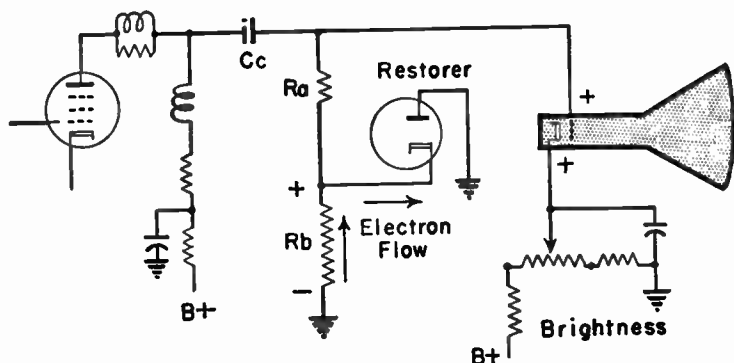

Fig. 10-8.—One method of using a diode for d-c restoration.

into the grid-cathode circuit of the picture tube. The restorer diode usually is one section of a twin diode whose other section is used as the video detector or for some other purpose. Electron flow through the restorer can be only in the direction indicated by arrows, with this flow passing upward through biasing resistor R_b . With this direction of flow the upper end of R_b is positive with reference to the lower grounded end. The upper end of R_b connects through another resistor, R_a to the picture tube control grid, while the lower end connects through ground and the brightness control to the picture tube cathode. Then the greater the electron flow in R_b the greater will be the voltage drop across it, and the greater the positive voltage applied to the picture tube grid.

Restorer diode R_b is connected across the signal input circuit. Consequently, the greater the signal amplitude the greater will be the potential difference across this diode and the greater will be the electron flow through the diode and resistor R_b . Thus a light toned signal increases the electron flow and causes application of more positive voltage to the picture tube grid. This voltage counteracts more of the negative bias from the brightness control and makes the net bias less negative. A dark toned signal decreases electron flow in the diode and in resistor R_b to make the bias more negative. As appeared in Fig. 10-7, these are the changes of grid bias required to compensate for pictures of lighter and darker tones.

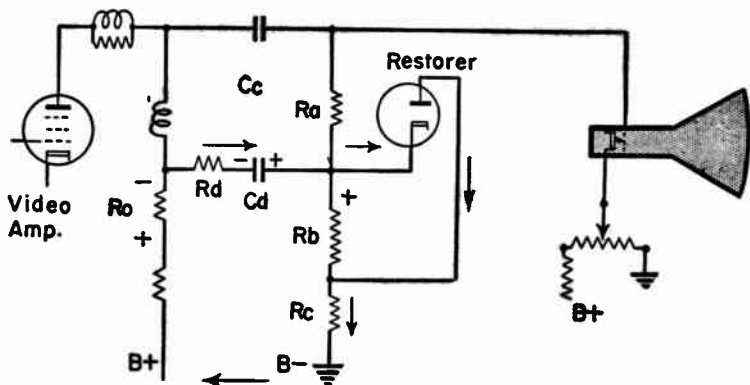

Fig. 10-9.—Another method of using a diode for d-c restoration.

If you connect a d-c electronic voltmeter from picture tube grid to ground, or from restorer cathode to ground across resistor R_b , the meter will show the changes of bias voltage. The meter will not interfere with observing a picture. As the picture tone becomes lighter the voltage will increase, and with darker pictures it will decrease, provided the restorer tube is acting correctly.

Fig. 10-9 shows another method of employing a diode for d-c restoration. Sync pulses in the plate circuit of the video amplifier act in load resistor R_o to produce the polarities shown. Electron flow then follows the path shown by arrows, through resistor R_d , capacitor C_d , from cathode to plate in the restorer diode, through R_c and the B-supply system back to the bottom of R_o . This electron flow charges capacitor C_d , positive toward the diode. The capacitor discharges between sync pulses. It cannot discharge through the diode, because the diode will not conduct in the reverse direction. Consequently, the capacitor has to discharge through the high resistance of resistor R_b which is connected across the diode. The result is positive polarity at the top of R_b and at the picture tube grid to which the top is connected. The voltage across R_b acts to vary the grid bias as required for pictures of various tones, just as does the voltage across R_b in Fig. 10-8. There are other types of d-c restoration circuits, but the general principles which have been discussed apply to all of them and explain the results to be expected.

Crystal diodes sometimes are used for d-c restoration. In still other cases the restorer is one section of a twin triode with grid and plate tied together to provide diode action. In a number of d-c restoration systems the cathode and grid of a triode are used like the cathode and plate of the diodes in preceding diagrams. From the plate of the triode then are secured sync pulses which are carried to the sync amplifiers, clippers or limiters which control the sweep oscillators.

Chapter 11

THE SYNC SECTION

The sweep oscillators which control voltages or currents for deflecting the electron beam in the picture tube must be kept in time with, or synchronized with, the incoming signal. Only thus may the beam be swept horizontally and vertically to keep pictures where they belong on the screen.

The vertical sweep oscillator is designed and adjusted to maintain a frequency very close to 60 cycles per second, which is the field frequency. The horizontal oscillator is designed and adjusted to operate at a frequency close to 15,750 cycles per second, the line frequency. But, even though an oscillator were precisely synchronized for pictures from one station, pictures from another station might be slightly earlier or later, even though of the same frequency. Furthermore, all oscillators of ordinary constructions suffer from slight drift of frequency.

The sweep oscillators are adjusted to go through their oscillation cycles just a little slower than required for picture timing. Then the vertical and horizontal sync pulses of the received composite signal are used to produce voltages which "trigger" the oscillators just before each oscillation cycle would naturally commence. Thus the actual periods of oscillation are forced to conform with the timing of whatever signal is received.

At the input to the sync section we always have the composite television signal. At the output we must have voltages suitable for triggering the oscillators. It is the function of the sync section to change the composite signal into triggering voltages which are applied to the vertical and horizontal sweep oscillators.

The change is brought about by passing the signal through a series of tubes which do four things. The sync pulses are separated from the composite signal and the video or picture elements of the signal are discarded. The sync pulses are amplified as may be required. The pulses may be trimmed down to a uniform height or amplitude when they tend to vary in different parts of the signal. The polarity of the pulses may be inverted

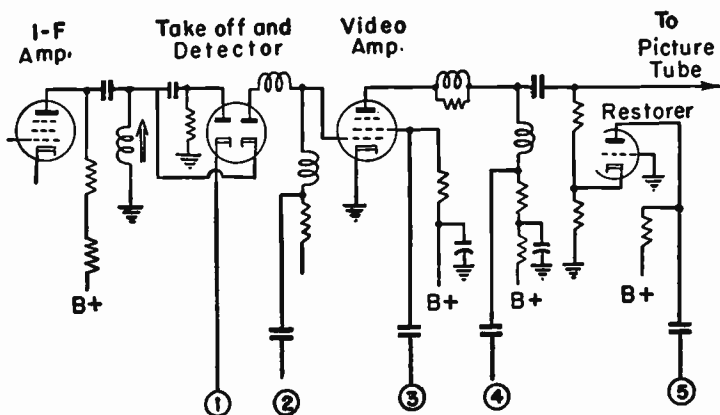

Fig. 11-1.—Points at which sync pulses may be taken from the video i-f and amplifying section of the receiver.

as required by the type of sweep oscillator. Some oscillators require negative voltages for triggering, while others require positive voltages.

The sync takeoff may be from almost any point where the signal contains the vertical and horizontal pulses. Some takeoff points are shown by Fig. 11-1. At 1 the takeoff is through a diode whose plate is coupled through a small capacitor to the output of the last i-f amplifier. The diode output will be the demodulated composite signal, with sync pulses positive when they are taken from the diode cathode, and negative when taken from the diode plate. With high resistance between the diode plate and ground, as shown, the time constant may be such that most of the picture signal is cut off at this point.

At 2 the sync takeoff is from the top of the load resistor in the video detector output. At 3 the takeoff is from the screen of a video amplifier. Note that this takeoff is directly from the screen, before any decoupling resistor and capacitor. At 4 the takeoff is from the high side of the plate load resistor of a video amplifier, again being ahead of all decoupling units. Takeoffs at the screen or plate load may be from any of the video amplifying tubes if the receiver has more than one.

At 5 the sync takeoff is from the plate of a triode restorer tube. In this particular type of restorer the grid is grounded to act

like the plate of a diode restorer tube, while the plate is connected to a low $B+$ voltage and to the sync circuits following. Sync takeoff may also be from the plate of a diode restorer tube, when the plate is not grounded. At the plate of any type of restorer tube there are strong negative sync pulses with only traces of the picture signal. It should be understood, of course, that in any one receiver there will be only one of these sync takeoffs used.

Waveforms in Sync Section.—Trouble shooting in the sync section usually is begun with observation of waveforms at various points between the takeoff and the final connection to the sweep oscillator in the vertical and horizontal systems. The method of observation is as follows:

1. Connect the vertical input of the oscilloscope to the point at which a waveform is to be observed. Do not use either the filter probe or the detector probe with the scope, for their capacitances will upset the action of the many filters in the sync section. Use a shielded cable with the shield grounded, or, at least, use a twisted pair lead to reduce unwanted pickup. In series with the vertical input connection, at the receiver end, have a fixed resistor or about one-half megohm resistance, or the greatest resistance which will allow traces of satisfactory height.

2. Tune in a picture or, preferably, a test pattern in the regular way. If it is impossible or very difficult to keep the picture stationary with the hold controls you have too little resistance in series with the vertical input for the oscilloscope.

3. To observe the vertical sync pulses use the internal sweep of the scope synchronized for 30 cycles. This will bring two fields

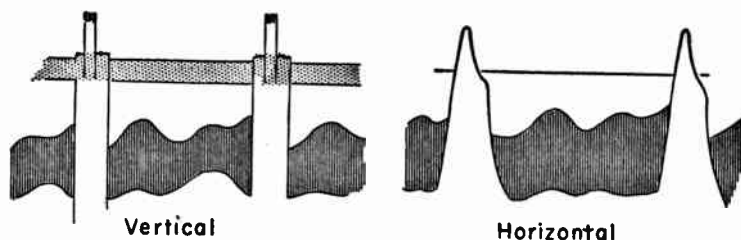

Fig. 11-2.—Oscilloscope traces observed at sync takeoffs.

and two vertical blanking intervals onto the screen. With the scope connected to points such as numbers 2, 3 and 4 of Fig. 11-1 the trace will show the complete composite signal, about as represented at the left in Fig. 11-2. It may be more satisfactory to use the sweep at 20 cycles to insure having two complete vertical blanking intervals on the screen.

4. To observe horizontal sync pulses use the internal sweep set for 7,875 cycles. The trace will have the general appearance shown at the right in Fig. 11-2 when from takeoff points at which there is a complete composite signal. It is possible also to use the internal sweep set for 5,250 cycles to insure having two complete horizontal blanking intervals on the screen at all times.

5. Follow the signal all the way through the sync section, applying the vertical input lead of the scope to the control grids, plates, and possibly the cathodes of all tubes in this section, also

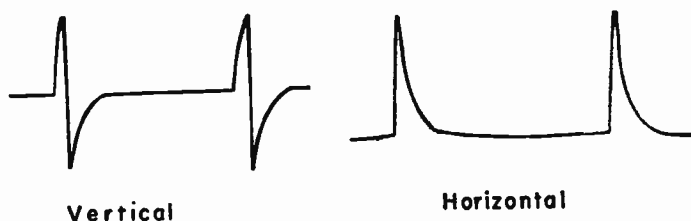

Fig. 11-3.—Triggering voltages for application to sweep oscillators.

to the input and output of filters preceding the sweep oscillators, and to the grids of the oscillators.

Fig. 11-3 shows vertical and horizontal triggering voltages as observed at the inputs or grids of certain kinds of oscillators. There is great variety in kinds and numbers of tubes in the sync sections of various receivers, and in the tube voltages and circuit connections used to change the signals from forms like those of Fig. 11-2 to such as shown by Fig. 11-3.

Fig. 11-4 shows the general appearance of vertical (30 cycle) and horizontal (7,875 cycle) traces obtained from the plate of a restorer tube, as at the takeoff numbered 5 in Fig. 11-1. Somewhat similar traces would be obtained from the diode takeoff numbered 1 in that diagram provided the diode circuit includes a coupling capacitor and a leak resistor. In the vertical trace

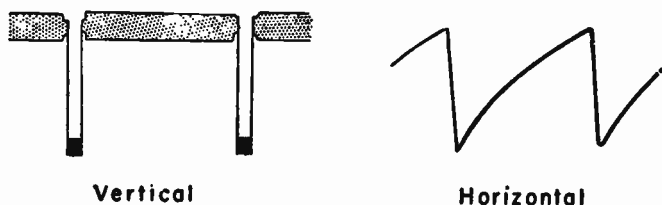

Fig. 11-4.—Synchronizing voltage traces from a restorer plate and from some kinds of takeoff diodes.

from these takeoffs the negative sync pulse is strong, and but little remains of the picture or video signal. In the horizontal trace there is no evidence of the picture signal.

The exact form of any of these traces depends not only on the receiver circuits but also on the oscilloscope. High input capacitance in the scope, or excessive capacitance in the input leads, will cause major changes in the trace forms. Frequency response or lack of it in the scope will change the slopes of the trace curves. All this is especially true when observing traces at the horizontal frequency.

Tubes in the Sync Section.—There are no generally recognized standards for naming the tubes used in sync sections. Sync amplifiers always increase the amplitude of the signal, but they may be operated to also change the form by strengthening the sync pulses at the expense of any remaining video signal. Sync separators help to strengthen the sync pulses while eliminating video signals. This may be done by bringing the signal to the separator with the sync pulses positive, and biasing the tube to provide plate current cutoff for all or nearly all the video signal. Tubes called sync clippers or sync limiters may make all sync pulses of uniform height or amplitude by means of biasing for plate current cutoff and sometimes by using plate and screen voltages so small as to provide plate current saturation for the positive peaks of the signals. The name clipper may be applied also to a tube which clips the sync pulses from the composite signal, and discards all or most of the video signal.

Every time a signal of any kind is applied to the control grid and taken from the plate of the same tube the signal polarity is inverted. There are many sync section tubes with which the output is taken from the cathode rather than from the plate.

Then there is no inversion of polarity. Frequently the output for one oscillator or for part of the circuit of an oscillator will be taken from the plate in one polarity, while for a separate oscillator or for another part of an oscillator circuit an output will be taken from the cathode of the same tube. The cathode output is of polarity opposite to that from the plate, and is the same as the polarity at the control grid of the tube.

What may be accomplished in passing a signal through a separator, a limiter, and an amplifier is illustrated by Fig. 11-5. The curves are grid-voltage plate-current characteristics for the tubes. The slopes of such characteristics are determined partly by the type of tube and partly by choice of voltages for plates and screen and for grid biases.

In the left-hand diagram the composite signal is applied to the grid of the separator, with sync pulses positive. The tube is

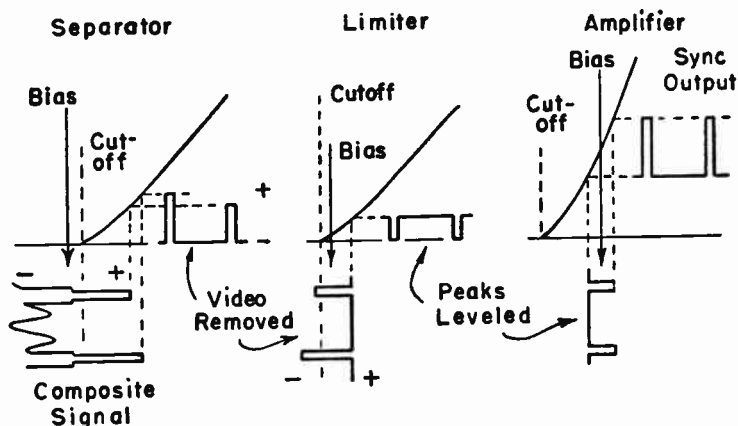

Fig. 11-5.—How three tubes in a sync section may separate sync pulses from the video signal and shape the pulses.

biased beyond cutoff, so only the more positive ends of the sync pulses cause conduction. In the output of the separator we then have no video signal, only sync pulses. The pulses are shown of unequal amplitude. This would not occur with adjacent pulses, which are shown so for illustration, but may happen at various times in a continuing signal and may happen when there are

various kinds of electrical interference which vary the amplitude modulation.

The signal with video removed, but with uneven sync pulses, is applied in the center diagram to the grid of the limiter. This tube is biased almost to cutoff, with the result that the uneven sync peaks are brought to a uniform level. Note that there is inversion of signal polarity between separator and limiter. The limiter output consists of uniform sync pulses with no video, but the pulses are of small amplitude. This output is applied to the grid of the amplifier tube in the right-hand diagram. This tube is operated to have a steep characteristic curve, which provides increased amplitude for the sync pulses while maintaining their uniformity.

Tubes in the sync section need not follow one another in the order shown by Fig. 11-5. Amplifiers may be used wherever it is desirable to increase signal strength. A tube for leveling the pulses often is the last one in the section.

Separation of Horizontal and Vertical Pulses.—Both horizontal and vertical sync pulses pass all the way through the tube circuits in the sync section. The two kinds of pulses are separated from each other by applying both of them to two kinds of filters, one of which passes the vertical pulse in the form of a voltage suitable for triggering a vertical sweep oscillator, while the other passes the horizontal pulses as triggering voltages for a horizontal sweep oscillator.

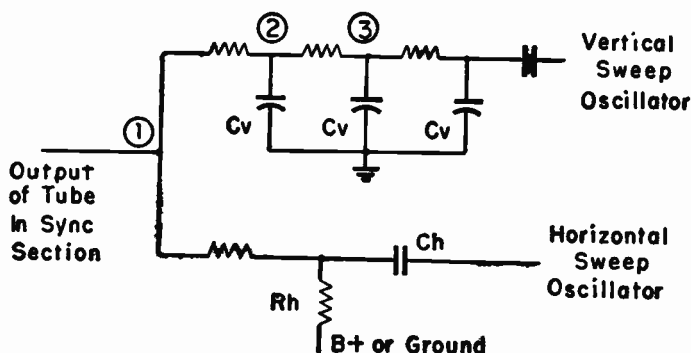

Fig. 11-6.—Typical connections for vertical and horizontal filters which separate the two kinds of pulses.

The two filters are of the general form shown by Fig. 11-6. The output of the last tube in the sync section is applied to both filters. The upper filter, leading to the vertical sweep oscillator, is a low-pass type. It is similar in principle to filters which follow the rectifier in B-supply systems, with resistances in series and capacitors from between the resistances to ground.

The vertical sync pulses are of long enough duration to build up a considerable charge and voltage on the capacitors at C_v . Shortly after the beginning of each serrated vertical sync pulse this voltage reaches a value which triggers the vertical oscillator. The capacitors discharge to near zero voltage between vertical sync pulses.

Capacitances at C_v are rather large, usually on the order of 0.002 to 0.01 mfd. The time constant of these capacitances and the filter resistances is long enough to allow building up the triggering voltage. That is, the charging rate is much greater than the discharge rate during the vertical sync pulses. But the time constant is not so long as to retain the charge and voltage after passage of the vertical pulses. When the individual horizontal sync pulses go into this vertical filter of long time constant, these very brief pulses cannot charge the filter capacitors to any appreciable voltage before there is discharge through the filter resistors during the line period following each horizontal pulse. Therefore, we have vertical triggering voltages, but no horizontal triggering voltages of any consequence, in the output of the vertical filter. This filter sometimes is called an integrating filter, because it builds up or integrates the effects of the serrated vertical pulse.

The filter leading to the horizontal sweep oscillator is a high-pass type, with a series capacitor C_h and a shunted resistor R_h . The capacitance at C_h is small, usually something between 100 and 200 mmfd. The time constant of this capacitance and the filter resistor is correspondingly short. The very brief horizontal sync pulses produce a charge and voltage sufficient for triggering before the capacitor can discharge, even with its short time constant. But the discharge rate of the capacitor in the horizontal filter is so great that the relatively long vertical sync pulses have no more effect than the horizontal pulses. There is a build-up of capacitor voltage at the leading edge of each vertical

pulse, but an almost instant discharge. Thus the vertical pulses between serrations, also the equalizing pulses, each produce the same sharp voltage pips as do the regular horizontal pulses. This is the effect necessary to preserve timing of the horizontal sweep oscillator during the vertical blanking intervals.

Following the sync signals through the vertical filter by means of the oscilloscope will produce traces such as those of Fig. 11-7, or of generally similar form. Traces in the upper row are taken with the internal sweep of the scope set for 30 cycles, to bring out the effects of vertical pulses. Those in the lower row are taken at 7,875 cycles to show the effects of individual horizontal pulses. Traces shown at 1 are taken at the input to both filters or at the output from the last tube in the sync section. This point is marked 1 in Fig. 11-6. Traces at 2 are taken at the input to the vertical filter, across the first filter capacitor. Traces at 3

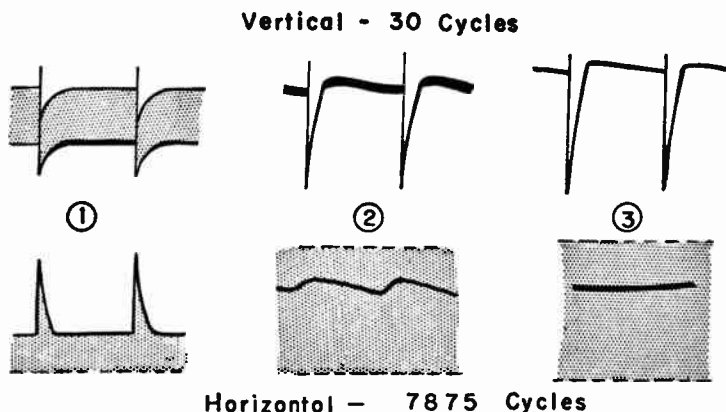

Fig. 11-7.—Oscilloscope traces at various points in a vertical filter.

are taken across the second filter capacitor. Still farther along in the filter, and at its output, the traces remain much the same as shown at 3.

As they progress through the vertical filter the vertical pulse voltages become continually sharper, while the horizontal pulse voltages gradually disappear. A similar examination of the horizontal filter would show at its input the same traces represented at the left in Fig. 11-7. At the output there will be horizontal

triggering voltages at the line frequency. These voltage traces will continue on the screen of the scope because the horizontal timing is continued throughout the vertical blanking interval by serrated vertical pulses, by equalizing pulses, and by regular horizontal pulses.

The output of either filter may be further amplified by another tube before going to the sweep oscillator. Certain types of sweep oscillators or oscillator controls require two timing voltages, of opposite polarity. These opposite voltages are obtained by applying the output of the horizontal filter to the grid of an inverter tube, then taking a voltage of one polarity from the plate and a voltage of opposite polarity from the cathode of the inverter.

Chapter 12

SWEEP OSCILLATORS

The great majority of television sweep oscillators are of either the blocking type or the multivibrator type. Both these lend themselves well to synchronization control by means of triggering pulses such as furnished from the sync section filters. The exceptions to these types of oscillators are found in some systems employing automatic control of horizontal sweep frequency.

A simple circuit for a blocking oscillator is shown by Fig. 12-1. Oscillation is maintained by feedback from plate to grid through the oscillation transformer. When B+ voltage is applied to the plate there is an increase of plate current through resistor R_b , the size control resistor, and the plate winding of the transformer. The changing plate current in the plate winding induces in the grid winding of the transformer a voltage which is positive at the grid of the oscillator tube. The positive grid voltage acts to further increase the plate current until it reaches saturation value.

At the instant of saturation there is no *change* of current in the plate winding, and the induced voltage at the grid drops to zero. This zero grid voltage, as compared with the former posi-

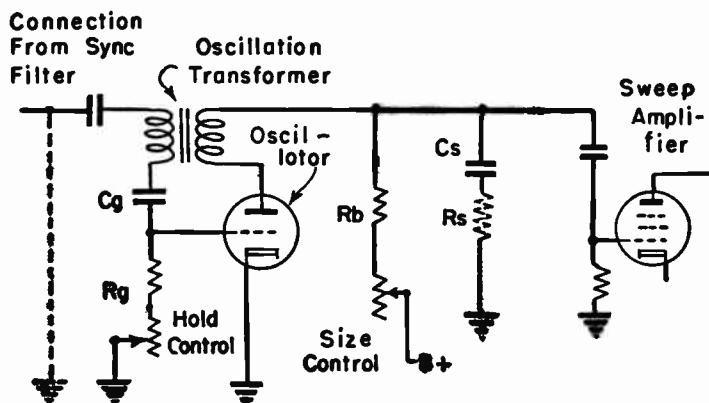

Fig. 12-1.—Connections in the circuits for a blocking oscillator.

tive voltage, causes a decrease of plate current. This decrease, being opposite to the earlier increase, induces a voltage in the grid winding which makes the grid negative. The grid becomes increasingly negative until reaching the value for plate current cutoff. Again, for an instant, there is no *change* of plate current. Grid voltage returns to zero. This zero grid voltage, as compared with the earlier negative voltage, allows plate current to increase. Then the whole process would repeat, with continuing oscillations of plate current at the resonant frequency of inductance and capacitance in the circuits, were it not for the effect of grid capacitor C_g and the grid resistor R_g , part of which is the hold control.

When the grid becomes positive there is electron flow from the grid through resistors R_g to ground, and through ground back to the cathode. With this direction of electron flow the upper end of R_g is made negative so strongly as to overcome the positive grid voltage and make the grid highly negative. There is an instant stoppage of plate current. The potential which makes the grid negative also charges the grid side of capacitor C_g in negative polarity. The grid is held negative by this charge until it can leak away through resistors R_g . The grid voltage is held beyond the value for plate current cutoff until enough charge leaks off to bring the voltage back to a value which allows resumption of plate current flow.

As soon as plate current resumes we have the oscillator action first described. During the first period of such oscillation, at the resonant frequency of the oscillator circuit, the grid is again made positive and then negative by the action of C_g and R_g . Then follows another period of plate current cutoff which lasts until capacitor C_g discharges sufficiently through R_g to permit another pulse of plate current.

It is plain that the actual frequency of oscillation depends on the time required for partial discharge of C_g . With any given capacitance at C_g this time depends on the resistance of R_g . The greater the resistance at R_g , as adjusted by the hold control, the longer the period for discharge and the lower the oscillation frequency.

The changes of voltage at the oscillator grid may be observed by connecting the vertical input of the oscilloscope to the grid.

If we are dealing with the vertical sweep oscillator the changes will be traced on the scope screen as at the left in Fig. 12-2. The brief instants of positive grid voltage are shown by the short upward "spikes." In the same instant the grid voltage goes far down in the negative direction. Then there is an upward curve of voltage as the grid capacitor discharges. This upward curve flattens off and ends at the point where the grid again goes positive.

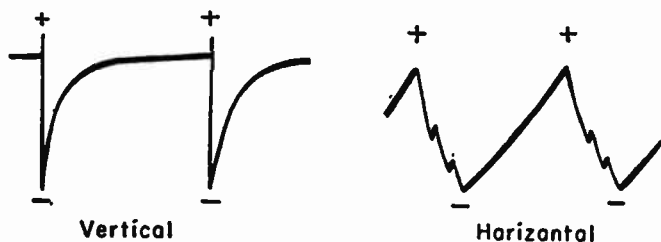

Fig. 12-2.—Traces observed with the oscilloscope connected to the grid of a blocking oscillator.

If a blocking oscillator is used for horizontal sweep the action which holds the grid negative to cut off plate current is the same as described, except for taking place at the higher horizontal frequency. With an oscilloscope connected to the grid of a horizontal blocking oscillator the trace will be somewhat as shown at the right in Fig. 12-2. The exact form of the trace depends not so much on the differences between circuit details as on the ability of the oscilloscope to follow the rapid changes of voltage which are taking place, or the lack of ability to follow such changes.

With the oscilloscope connected to the plate of the blocking oscillator the traces at the vertical and horizontal frequencies

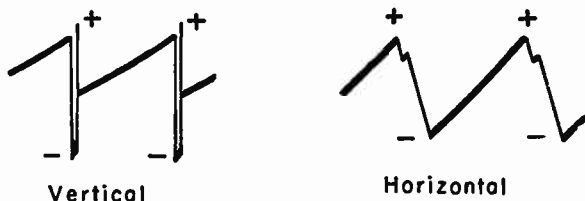

Fig. 12-3.—Traces observed with the oscilloscope to the plate of a blocking oscillator.

will be about as shown by Fig. 12-3. These traces represent changes of plate voltage. The long downward negative extension of the trace shown on the vertical diagram will exist only when resistor R_s of Fig. 12-1 is in series with capacitor C_s of that figure. This resistor, and the accompanying plate voltage curve, are found where the picture tube is operated with magnetic deflection. For electrostatic deflection tubes the downward negative swing of plate voltage is not required, and the resistor is not used in series with C_s . The long negative swing of plate voltage occurs also with a blocking oscillator used for the horizontal sweep, but it will not show on the trace formed by ordinary types of oscilloscope. The horizontal trace will appear on the screen of the scope about as shown at the right in Fig. 12-3.

Since the oscillator plate and capacitor C_s are directly connected, the voltage traces of Fig. 12-3 are for capacitor voltage as well as for plate voltage. These are the "sawtooth" voltages which will be used to produce other voltages, or currents, of

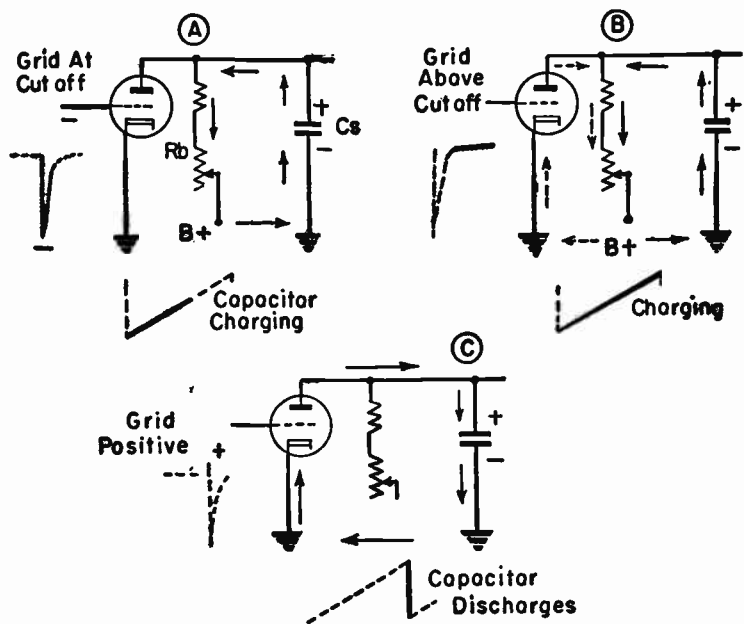

Fig. 12-4.—How a sawtooth voltage is formed while the oscillator first is non-conductive or blocked, then is conductive.

similar form to deflect the beam in the picture tube. The whole purpose of the sweep system is to produce these sawtooth voltages or currents.

How the sawtooth voltage is formed is illustrated by Fig. 12-4, which shows part of the more complete diagram of Fig. 12-1. We commence at diagram *A* with the grid negative beyond the value for plate current cutoff. There is no plate current in the tube. Capacitor *Cs* and resistors *Rb* are in series across the B-supply. Electron flow is in the direction of the arrows, and the capacitor is charged in the indicated polarity. The charging curve, shown below the diagram, rises rather slowly because the rate of electron flow for the capacitor is limited by the resistances at *Rb*. This is a matter of time constant.

In diagram *B* the grid voltage has risen from its cutoff value and is allowing plate current to commence. Electron flow for this plate current is represented by the broken line arrows. The capacitor continues to charge, as shown by the full-line arrows. The charging curve is completed; it is the gradual upward slope of the sawtooth voltage.

In diagram *C* the grid voltage becomes positive. With a positive grid the internal resistance or plate-cathode resistance of the tube drops nearly to zero. The high voltage which has been built up on capacitor *Cs* by charging action now causes instant discharge of the capacitor through the very low resistance of the tube. Electron flow in this discharge is indicated by arrows. The curve of capacitor voltage, shown below the diagram, takes a sudden downward plunge to complete the sawtooth. Thus we produce the sawtooth voltage waves observed in Fig. 12-3.

Discharge Tube on Oscillator.—In the blocking oscillator circuit previously discussed there is discharge of the sawtooth capacitor *Cs* through the cathode-plate path in the oscillator tube. In Fig. 12-5 there is a separate tube or a second section of a twin tube providing the discharge path, while the oscillator tube or section acts only to control the periods of charge and discharge.

The oscillator of Fig. 12-5 acts exactly like the one of Fig. 12-1 so far as changes of grid voltage are concerned. That is, the timing of oscillation cycles is controlled by action of grid capacitor *Cg* and grid resistors *Rg* in accordance with their time con-

stant. The grid of the oscillator is directly connected to the grid of the discharge tube. Then the grid of the discharge tube must go through the same changes of voltage as the grid of the oscillator, and at the same instants of time.

While the two grids are held negative beyond plate current cutoff there is charging of sawtooth capacitor C_s , just as in the former circuit. When the two grids become instantaneously positive the internal resistance of the discharge tube drops

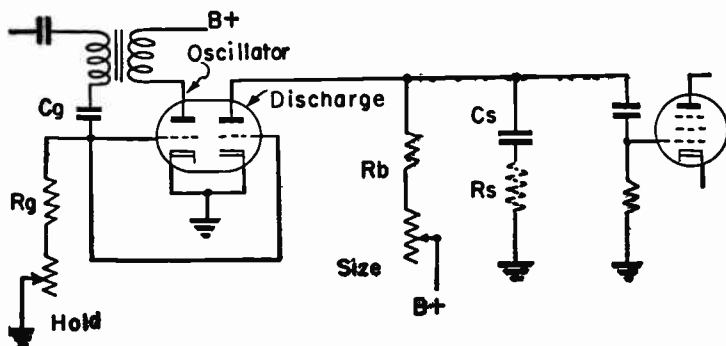

Fig. 12-5.—Blocking oscillator with discharge tube.

nearly to zero, and capacitor C_s discharges through the cathode-plate path in the discharge tube. Using a separate discharge tube allows operating the oscillator at a higher plate voltage than used for the discharge tube and for the sawtooth capacitor.

Multivibrator Sweep Oscillator.—The Potter sweep circuit used in television as a sweep oscillator is an adaptation of the long known multivibrator circuit used in many electronic applications for production of square pulses. Fig. 12-6 is a typical diagram for the television form of multivibrator. There is no feedback transformer such as required by the blocking oscillator. The multivibrator employs two tubes or the two sections of a twin tube, with sync pulses applied to the grid of section A in the diagram. These pulses sometimes are applied to the upper end of the cathode resistor which is common to both sections. Sawtooth capacitor C_s and resistor R_s are the same as in previously described oscillator circuits.

To follow the action in the multivibrator consider first an instant in which B+ voltage from the supply line at the upper

left is causing electron flow in the path marked with full-line arrows. This flow is from ground through cathode resistor R_k to the cathode of tube section B , thence to the grid of this section, into and out of grid capacitor C_g , through resistor R_a and to $B+$. Capacitor C_g is charged in the polarity marked. Resistor R_k is acting as a cathode bias resistor, with its negative lower

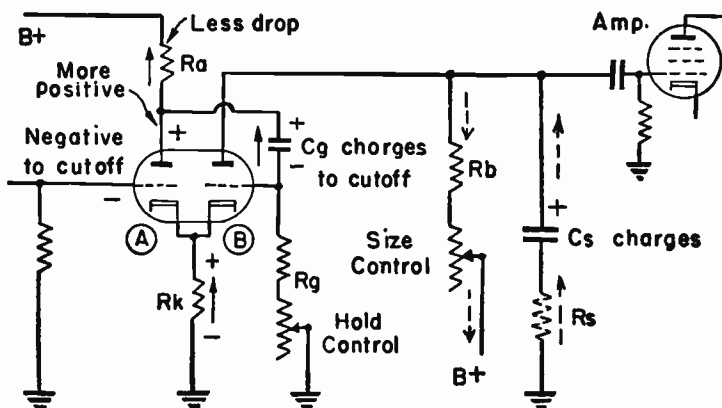

Fig. 12-6.—Connections for a multivibrator sweep oscillator.

end connected through ground to the grid of section A . This grid is made negative to the point of plate current cutoff. The decreasing plate current allows a decreasing voltage drop across series resistor R_a , and an increasingly positive voltage at the plate of section A . This increasingly positive voltage causes additional charging of capacitor C_g , whose polarity drives the grid of section B so far negative as to cause plate current cutoff in this section. Sawtooth capacitor C_s now charges from the B -supply through the path indicated by broken-line arrows.

Now we may go on to Fig. 12-7. The decreases of plate current in the tube sections bring about less current and less voltage drop on cathode resistor R_k . This smaller drop in R_k makes the grid of section A less and less negative, so that plate current commences to flow and to increase in this section. The increasing plate current flows in resistor R_a to increase the voltage drop across R_a and make the voltage at the plate of section A become

less positive. This less positive voltage acts on one side of grid capacitor C_g , and this capacitor commences to discharge. This discharge cannot flow in reverse from grid to cathode of section B , so it takes place through resistances at R_g and the hold control.

The time constant of capacitor C_g and resistors R_g determines how long it takes for grid voltage on section B to reach a value allowing plate current in this section. When this value

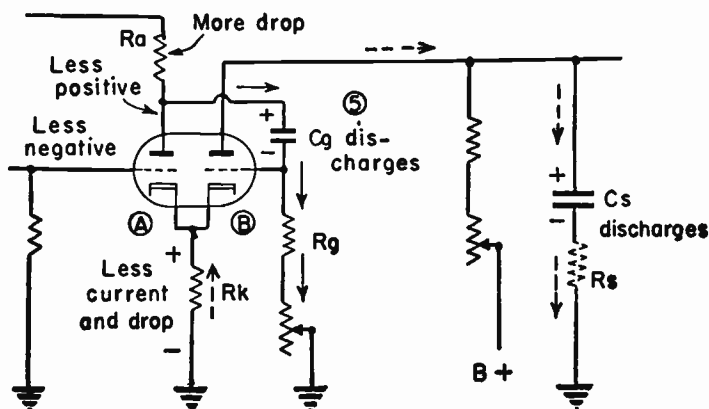

Fig. 12-7.—Discharge of the sawtooth capacitor in the multivibrator circuit.

is reached, there is instant discharge of sawtooth capacitor C_s through section B and the path shown by broken-line arrows. The very large discharge current of the sawtooth capacitor flows through resistor R_k to make the grounded end of this resistor highly negative with reference to the cathode end. Then both grids are made so negative as to cause plate current cutoff. This stops discharge of the sawtooth capacitor, and it again charges during the cutoff period or non-conductive period of tube section B .

The time periods between successive discharges of the sawtooth capacitor, or the periods during which this capacitor charges, are the periods required for grid capacitor C_g to partially discharge through resistors R_g . The length of these periods may be altered by adjusting the resistance of the hold control.

Fig. 12-8 shows waveforms of the general types to be expected with the oscilloscope connected to the various elements of a multivibrator used for vertical sweep. The input voltage pulses applied from the vertical sync filter are shown opposite the left-hand grid. These pulses usually have potentials of only a fraction

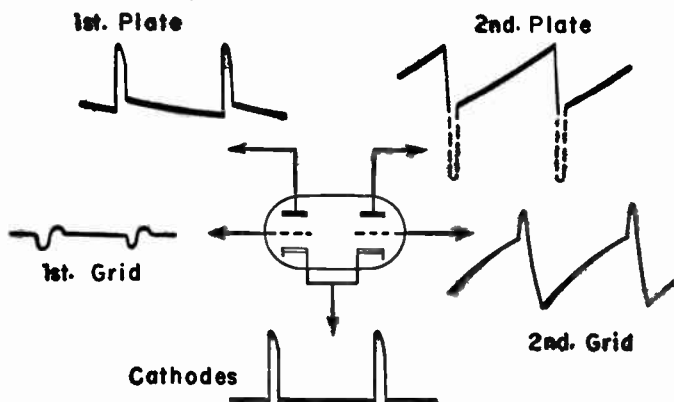

Fig. 12-8.—Waveforms observed at the several elements of a multivibrator used for vertical sweep.

of a volt and may be difficult to observe at the horizontal frequency. Voltage pulses at the first plate, which act on the grid voltage of the second section, are shown above the left-hand plate. The changes of voltage at the second grid are affected by charge and discharge of the grid capacitor, as is evident from

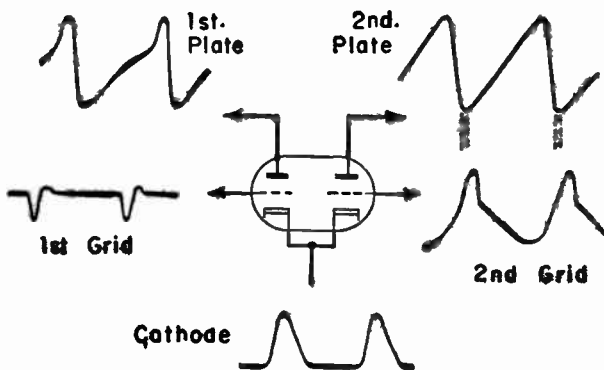

Fig. 12-9.—Waveforms from a multivibrator used for horizontal sweep.

the rather gradual slopes of the trace. The output from the second plate will be a plain sawtooth wave where the picture tube operates with electrostatic deflection. With magnetic deflection picture tubes the output wave will have the sharp negative dip preceding the upward slope which indicates charging of the sawtooth capacitor. How well this dip is seen on the trace will depend largely on the frequency response of the scope.

Fig. 12-9 illustrates waveforms such as may be observed with the scope at the elements of a multivibrator used for horizontal sweep. The relations of scope trace forms to actual variations of voltage in the circuits again depends to a great extent on the frequency response of the instrument. This applies to measurements at the horizontal frequency even more than with measurements at the vertical frequency.

Polarity of Oscillator Sync Pulses.—When examining the blocking oscillator without a separate discharge tube, and also with one, we found that the sync pulse applied to the oscillator grid must be positive. The result of a positive pulse is discharge of the sawtooth capacitor.

The multivibrator operated with sync input to the grid of the first section must have this sync voltage of negative polarity. The negative voltage at the first grid instantly produces a positive voltage at the second grid and allows discharge of the sawtooth capacitor through the second section. But if sync input to the multivibrator is applied at the top of the cathode resistor this pulse must be of positive polarity. A positive voltage at the cathode is equivalent to a negative voltage at the grid.

Sawtooth and Square Pulse Voltage.—Earlier it was mentioned that in receivers having a picture tube with magnetic deflection it is necessary to have the rise of sawtooth voltage preceded by a negative pulse which is part of a square wave, as shown at the left in Fig. 12-10. If a sawtooth voltage without the square wave is applied to a deflection coil the current produced in the coil will not be of sawtooth form, as required for correct travel of the picture tube beam. When the sawtooth voltage wave is preceded with a square wave, the coil current will not show the square wave but will be truly sawtooth.

The negative square pulse is produced as follows: When the sawtooth capacitor discharges, with electron flow shown by arrows

at the right in Fig. 12-10, the flow is through resistor R_s . The rate at which the capacitor discharges then is slowed down, it proceeds as determined by the time constant of C_s and R_s . This time constant is long enough to prevent complete discharge of the capacitor while the tube is conductive. While the grid is positive, voltage across the tube between plate and cathode, and also across the sawtooth capacitor, drops all the way from a to b on the curve. But because of R_s being in the discharge circuit the capacitor still retains some charge when voltage reaches b . This remaining charge is still on the capacitor when the tubes again become non-conductive. There has been a further slight voltage drop from b to c during the conduction period.

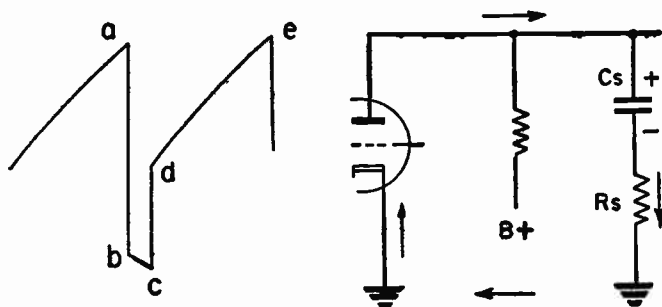

Fig. 12-10.—How a negative square wave is added to the sawtooth wave when the picture tube is operated with magnetic deflection.

The effect of the retained charge is to instantly raise the capacitor voltage, and voltage across the tube, from c to d just as soon as the tube ceases to conduct. Then the capacitor commences to gain further charge in the regular way, and voltage rises along the sawtooth part of the curve from d to e , which brings us to the start of another similar cycle.

If resistor R_s is adjustable, as it is with some controls to be examined later, the time constant is changed and more or less charge is retained on the sawtooth capacitor. This will alter the instantaneous rise of voltage which follows discharge, will alter the distance between c and d on the curve, and, of course, will also cause a change in the slope of the sawtooth voltage rise from d to e .

Size Control.—In earlier circuit diagrams for the various sweep oscillators there is an adjustable resistor in series with the B+ lead through which the sawtooth capacitor is charged. This resistor has been marked *Size Control*. In vertical sweep systems it would vary the height of the picture, and might be called a *height control*. In horizontal sweep systems this control would vary the width of the picture, and might be called a *width control*.

During the increase of voltage or current accompanying the charging of the sawtooth capacitor the picture tube beam is deflected from left to right for a horizontal line, or downward during formation of a field. During the very fast discharge of the sawtooth capacitor the beam travels from right to left for horizontal retrace, or from bottom to top for a vertical retrace.

If the size control in a horizontal system is adjusted for less resistance there will be more rapid charging of the sawtooth capacitor during the time in which the tube is non-conductive, the capacitor voltage will become greater before there is discharge, and the beam will be carried farther across the picture tube screen. This means greater width or height, as the case may be. Adjusting the size control for more resistance slows the rate of charging, lowers the voltage which can be reached before discharge, and allows the beam to travel shorter distances on the screen.

Later we shall examine other types of size controls found in the circuits of the sweep amplifiers. Any control for horizontal size or width should be adjusted so that the picture or test pattern fills the mask opening from left to right, and any control for vertical size or height should be adjusted to fill the mask opening from top to bottom. There is interaction between size controls and various other controls, especially between size controls and those which are called linearity controls and those called drive or peaking controls. When any one of these controls is adjusted, the others have to be adjusted at the same time.

Hold Controls.—On the circuit diagrams for blocking oscillators there are shown adjustable grid resistors marked *Hold Control*, and on diagrams for multivibrators there are grid resistors on the second tube section having similar markings. These hold control resistances vary the time constant of the grid capacitor and resistor to vary the intervals between discharges of the saw-

tooth capacitor or to vary the operating frequency of the sweep oscillator. The operating frequency which results from adjustment of these hold controls may be called the *free running* frequency, because it is the frequency existing when no sync pulses are being applied to the oscillator circuit.

At the top of Fig. 12-11 is represented a sawtooth wave of a frequency which might exist with the oscillator running free. We consider the oscillation cycles to start at the beginning of dis-

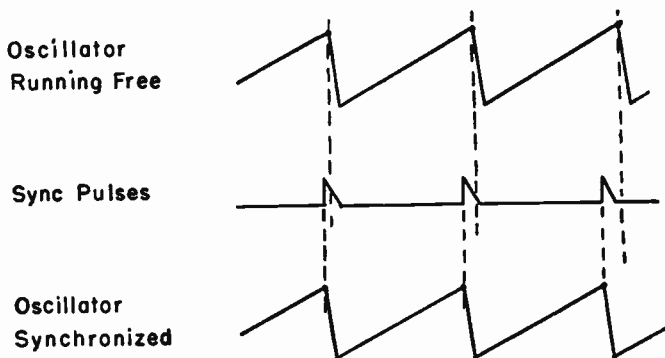

Fig. 12-11.—How sync pulse voltages bring the oscillator into time with the received signal.

charge from the sawtooth capacitor or at the beginning of each retrace. Next below are represented sync pulse voltages which come from the sync section and are applied to the oscillator. The leading edge of each sync pulse makes the oscillator grid positive just before it would have become positive at the free running fre-

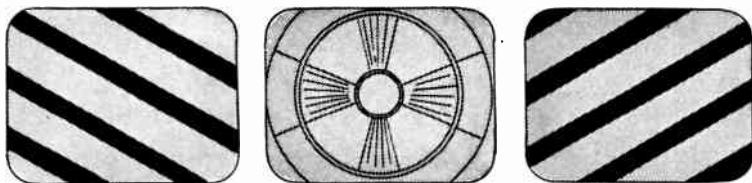

Fig. 12-12.—Changes produced in a pattern during adjustment of a horizontal hold control.

quency, without the sync pulse. Then the oscillator commences a cycle which is in time with the sync pulse. The hold control is adjusted to make the free running frequency so nearly like the sync frequency that oscillations are easily kept synchronized with the received signal.

When a horizontal hold control is working correctly, the picture or pattern on the picture tube screen will go through the changes of Fig. 12-12 as the control knob is turned continually in one direction. When the oscillator is very nearly synchronized there will be a number of black bars sloping in one direction, as at the left. Elements of the picture or pattern are crowded in between these black bars. At one point of adjustment the picture or pattern will lock into synchronization, as at the center. Continued turning of the control in the same direction will cause the sloping bars to reappear, but now they will slope the opposite way, as at the right. The closer we come to correct synchronization the more nearly vertical will be the black bars.

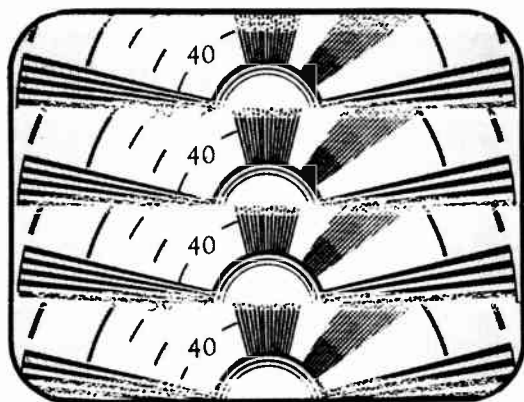

Fig. 12-13.—Movement of pattern with the vertical hold slightly out of adjustment.

Sometimes the picture will remain locked into synchronization with the hold control turned to its limit in one direction, and will drop out in the opposite direction. This is satisfactory operation. With some circuits there may be lock-in with the hold control in either of two positions, but in one position there will be a vertical black bar somewhere near the center of the picture.

When a vertical hold control is working correctly, and is adjusted close to the point of synchronization or lock-in, the picture or pattern will move slowly up or down to give somewhat the effect of Fig. 12-13. The picture will lock in upon a little further adjustment of the control. Sometimes the picture will become stationary with the bottom portion appearing above the top portion, as in Fig. 12-14. Adjustment of the vertical hold control should correct this.

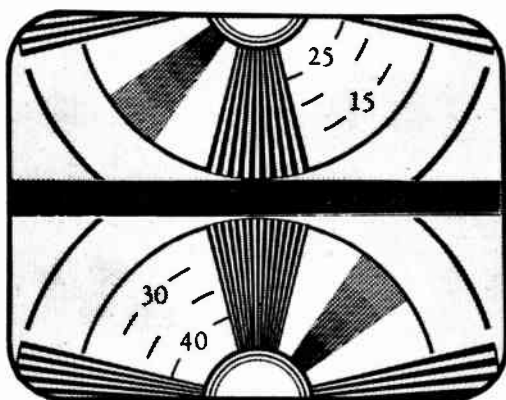

Fig. 12-14.—Misadjustment of the vertical hold may split the pattern.

There always will be a difference between the adjustment range throughout which a picture will hold its synchronization and the range through which the picture will pull back into synchronization after being dropped out. If you commence with the control knob turned to its limit either way, then rotate it slowly, there will be a certain position at which the picture will pull into synchronization. If you then turn the knob back toward the starting point the picture will not drop out at the same point it pulled in, but will hold its synchronization until the knob is rotated quite a ways back.

The correct adjustment is midway between the pull-in points determined by rotating the knob or screw from each extreme limit of travel back toward the center of the range. During this setting of the control the picture may be dropped out, to note whether it will pull in again, by momentarily switching to another channel, by turning the power off and then on again, and sometimes by turning the contrast control lower.

If the contrast control is such as varies signal amplitude ahead of the sync takeoff point, the pull-in and hold-in points of the hold adjustment will be affected by setting of the contrast control. Too little contrast will make it difficult or impossible to hold synchronization, because the sync pulses are then too weak.

If hold controls cannot be adjusted to keep the picture synchronized either vertically or horizontally the trouble probably is in the sync section which supplies pulses to both oscillator systems. Check the sync tubes by substitution. Use the oscilloscope to follow the signal through this section. Look for leaky capacitors and defective resistors. If only the horizontal sync or only the vertical sync is out, but not both, try substitution of the oscillator tube in the affected section, also of a discharge tube if used. Observe waveforms in the affected system. Look for leaky capacitors, defective resistors, bad connections, and all the usual troubles found in radio circuits. It should go without saying that measurements of tube voltages are in order in any circuit where the fault appears to lie.

Chapter 13

AUTOMATIC CONTROL OF SWEEP FREQUENCY

The relatively high frequency at which horizontal sweep oscillators are operated makes them more susceptible to upset from all kinds of electrical interference than the vertical sweep oscillators. In order to maintain the horizontal sweep frequency many receivers contain circuits which automatically return this frequency to synchronization when it tends to vary. There are a great many methods of horizontal afc (automatic frequency control), but all may be placed in two general classifications.

In one of these classes the horizontal oscillator frequency is controlled with variations of effective inductance or capacitance in the oscillator tank circuit. The effective inductance or capacitance is varied by means of a reactance tube. In the other class there is automatic control of grid bias on either a blocking oscillator or a multivibrator oscillator. Varying the average grid voltage, or the bias, of either of these oscillators will vary their free running frequency. This type of control is based on combining a sync pulse voltage with a voltage wave obtained from the output sweep circuit.

Reactance Tube.—An elementary circuit for a reactance tube and a controlled oscillator is shown by Fig. 13-1. The particular oscillator shown here is a Hartley type, evident from the fact that its cathode is connected in between the ends of tuning inductor L_a - L_b . The diagram shows both tubes as triodes. Either or both might be a pentode without changing the operating principle.

Capacitor C_p and resistor R_p are in parallel with the tuned circuit of the oscillator. Consequently, across this capacitor and resistor is applied voltage at the frequency of oscillation. The capacitance at C_p is very small, as is also the resistance at R_p . Then the capacitive reactance is large in comparison with the resistance. In any circuit where the reactance is chiefly capacitive the current leads the applied voltage. The lead would be 90 degrees were the reactance wholly capacitive. Because of this condition the current through R_p leads the oscillating applied voltage by almost 90 degrees.

In any resistance the current and voltage must be in phase, with neither lag nor lead. Then, since the voltage across R_p must be in phase with its current, this voltage is leading the applied oscillating voltage by almost 90 degrees. Resistor R_p is between cathode and ground of the reactance tube, so the voltage existing across R_p is applied to the reactance tube as a signal. This signal

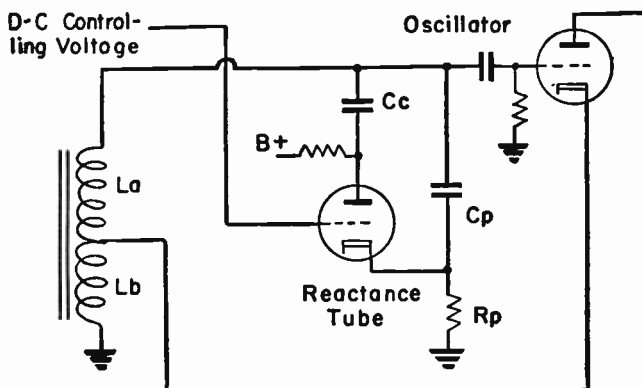

Fig. 13-1.—A reactance tube for controlling the frequency of an oscillator.

voltage, leading the oscillator voltage, is amplified by the reactance tube and put into the tuned circuit of the oscillator through coupling capacitor C_c .

The leading voltage from the reactance tube combines with the original oscillator voltage to make the resulting voltage leading with reference to that which would exist without the reactance tube. A leading voltage, or lagging current, in any ordinary tuned circuit is the kind accompanying more inductance in that circuit. We have here the same effect as though inductance were added to the tuned circuit. The result is a lowering of oscillator frequency, as would be caused by addition of actual inductance to the tuned circuit.

The strength of leading voltage from the reactance tube depends on the gain in this tube. The gain may be varied by changing the voltage of the grid in relation to the cathode voltage of the reactance tube. The less negative the grid the greater will be the gain and the more the oscillator frequency will be lowered. Making the grid more negative allows oscillator frequency to

approach its value with no reactance tube. The d-c controlling voltage for the grid may be obtained from either a discriminator or a phase detector, the latter being generally similar to a ratio detector used in sound circuits.

Afc Discriminator.—Fig. 13-2 shows a discriminator circuit for furnishing to the grid of the reactance tube a d-c voltage which varies with any changes of oscillator frequency. At the right are parts *La* and *Lb* of the tuned winding of the oscillator circuit in Fig. 13-1. These now are the primary of the discriminator trans-

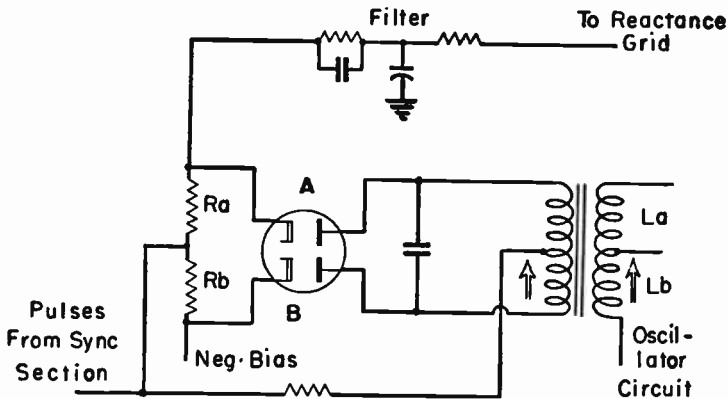

Fig. 13-2.—Discriminator operated by sync pulses and oscillator voltage, and furnishing a grid voltage for a reactance tube.

former whose secondary connects to the plates of the discriminator diodes. Oscillator current in the primary follows a sine wave and induces in the secondary a sine wave voltage which is alternately positive and negative at the diode plates with respect to the secondary center tap. During the half-cycle in which each diode plate is positive, that diode will conduct. Current in diode *A* will flow in resistor *Ra* and back to the center tap of the transformer secondary. Current in diode *B* will flow in resistor *Rb* and to the center tap. These currents are in opposite directions in *Ra* and *Rb*. If the currents are equal the voltage drops across the resistors will be equal and opposite, leaving the net voltage difference zero across both resistors. This is just what happens when the oscillator frequency coming through the transformer coupling is exactly equal to the frequency for which the transformer secondary is tuned.

If oscillator frequency becomes higher or lower there will be more current in one diode than in the other, as is the case with any discriminator. Then there are unequal currents and unequal voltages in resistors R_a and R_b , with the result that the voltage difference across both resistors no longer is zero, but is positive or negative in accordance with which way the oscillator frequency has changed.

The top of resistor R_a is connected through a filter system to the grid of the reactance tube. The bottom of R_b is connected to a bias voltage $1\frac{1}{2}$ or 2 volts negative, which is the bias for the reactance tube grid. If the voltage at the top of R_a becomes positive with reference to voltage at the bottom of R_b , due to change in oscillator frequency, the voltage is made less negative at the grid of the reactance tube. This increases the gain in the reactance tube, adds more inductance effect in the oscillator tuned circuit, and lowers the oscillator frequency. If the discriminator voltage becomes negative, due to oscillator frequency changing in the opposite direction, the bias for the reactance tube becomes more negative. This reduces the gain in that tube, lessens the inductive effect in the oscillator tuned circuit, and oscillator frequency increases.

Any variation of oscillator frequency away from the resonant frequency of the transformer secondary causes a discriminator d-c voltage which acts through the reactance tube to bring the oscillator frequency back where it belongs.

Sync pulses are put into the discriminator circuit through the connection at the lower left. These pulses are applied to the center tap of the transformer secondary, consequently act through both halves of this winding to make both diode plates positive and negative at the same time. Only positive pulses cause conduction. Currents in the two diodes flow in opposite directions in resistors R_a and R_b , producing equal and opposite voltage drops which cancel so far as output to the reactance grid is concerned, at least so long as the currents and voltages are equal.

If oscillator frequency becomes faster or slower than sync pulse frequency there are unequal voltages applied to the two diode plates, unequal currents and voltages in resistors R_a and R_b , and a difference voltage across these resistors which be-

AUTOMATIC CONTROL OF SWEEP FREQUENCY 247

comes either positive or negative in accordance with the direction in which oscillator frequency changes.

The action is illustrated by Fig. 13-3. The sine waves represent diode plate voltages due to the oscillator frequency. These waves are in opposite phase at the two diodes. Added sync voltage pulses are shown on the sine waves. When the oscillator is in time with the sync pulses the pulse voltages occur as the sine waves go through zero, and add equally to voltages on the plates of both diodes to produce no effect on the reactance tube.

If the oscillator frequency becomes fast in relation to the sync pulses, the pulse voltages drop lower for diode *A* while rising

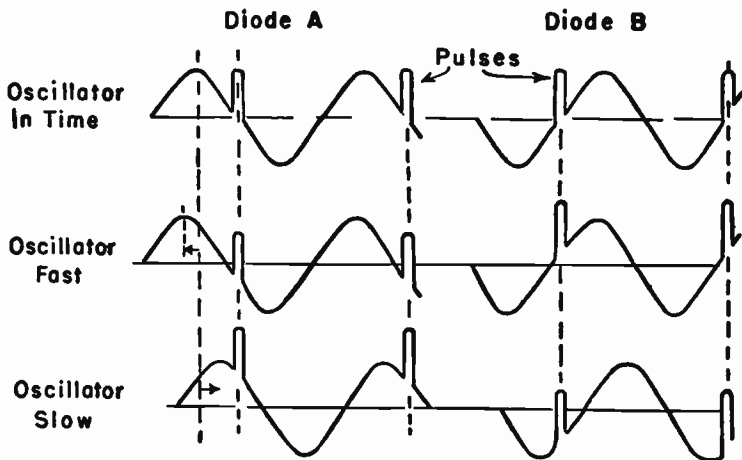

Fig. 13-3.—How sync pulse voltages and oscillator voltage combine in the discriminator.

higher for diode *B*. Then there is more current in diode *B* than in *A*, unbalanced voltages in resistors R_a and R_b , and a correction voltage is applied to the reactance tube grid. If oscillator frequency becomes slow the sync voltages rise higher for diode *A* than for diode *B*, and a correction voltage of opposite polarity goes to the grid of the reactance tube.

Voltage waveforms as shown by Fig. 13-3 exist at the pins of the discriminator tube, but are difficult to observe with the oscilloscope because of the high frequencies involved and because the oscilloscope leads upset the timing and destroy the wave-

form. The oscillator generates approximate sine waves. These may be observed with the scope connected to the oscillator grid, to the reactance tube cathode, and to the reactance tube plate. The sine waves come through the discriminator transformer, and may be observed at the discriminator tube. The added sync pulses are on the sine waves in the discriminator circuit only while a signal is being received.

The filter shown in Fig. 13-2 between discriminator output and reactance tube grid prevents electrical interference from affecting the oscillator timing. Voltage pulses due to interference can add themselves to the sine waves much as do the regular sync pulses. When the interference pulses are of very short time duration they make only a momentary change in discriminator output voltage. The filter is a time delay network which passes only the average effect of voltage changes from the discriminator, and momentary interference pulses do not get through the filter.

A complete diagram for a horizontal afc system using a discriminator is shown by Fig. 13-4. Circuits for the discriminator, reactance tube, and oscillator are the same as in other diagrams, but the latter two tubes are shown as pentodes. In some receivers the transformer secondary is connected to the discriminator

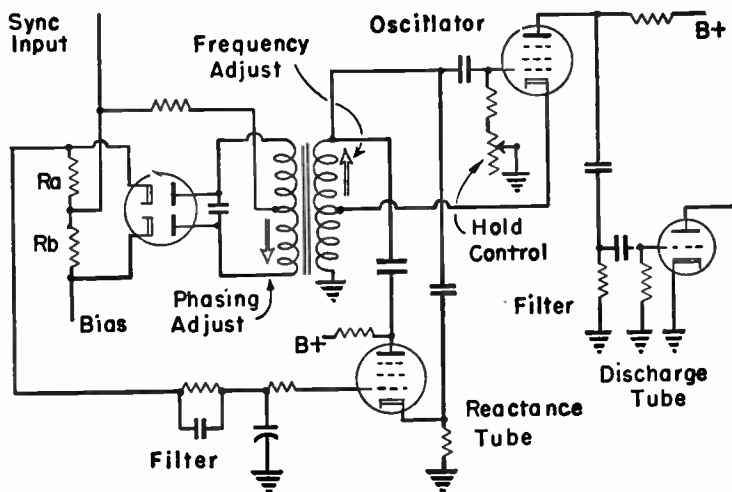

Fig. 13-4.—Horizontal afc system employing a discriminator and a reactance tube.

AUTOMATIC CONTROL OF SWEEP FREQUENCY 249

diode cathodes, with the load resistors between the diode plates.

To the oscillator plate is coupled a discharge tube which acts like discharge tubes previously examined. Between oscillator and discharge tube is a high-pass filter which changes the output voltage of the oscillator into sharply peaked pulses which make the grid of the discharge tube momentarily positive. This allows discharge of the sawtooth capacitor, which is in the plate circuit of the discharge tube.

Afc Discriminator Adjustment.—As shown by Fig. 13-4 there are three adjustments in this afc system. The hold control on the oscillator grid is a front panel control for use by the operator. The frequency adjustment is a slug which tunes the transformer primary or oscillator winding, and the phasing adjustment is a slug which tunes the secondary winding. These are service adjustments. The frequency slug is reached from the top of the transformer, the phasing slug from the bottom. Adjustment procedure is as follows:

1. Tune in a signal, preferably one carrying a test pattern.
2. The pattern or picture should hold in synchronization with the hold control rotated from the center of its range all the way or nearly all the way to either extreme position, or through the center two-thirds to three-fourths of its range.
3. If the pattern or picture does not hold in as described, vary the frequency adjustment until the condition is corrected.

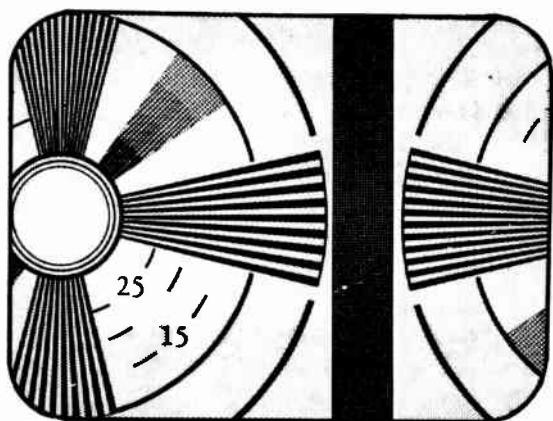

Fig. 13-6.—A blanking bar in the picture area indicates misadjustment of the discriminator phasing control.

4. The phasing adjustment requires attention if there is a vertical black blanking bar in the picture area, as illustrated by Fig. 13-5, or if one side appears as though folded over. Adjustment is made according to the following steps.

5. Set the hold control at its center position.

6. Set the contrast control somewhat below normal position and turn up the brightness until diagonal white lines just become visible.

7. Adjust the phasing slug to move the blanking bar just out of the picture area on the right-hand side, leaving the left side of the pattern or picture close to the raster edge, and without either fold-over or vertical white streaks on the left.

8. As the hold control is rotated the pattern or picture should move to the right and left, but should remain synchronized through all or most of the hold control range. If there is fold-over it should be approximately equal on both sides as the hold control is turned one way and then the other.

9. With the hold control in various positions turn the receiver off and on again. The pattern or picture should pull in through most of the hold control adjustment range.

Phase Detector and Reactance Tube.—In Fig. 13-6 the horizontal oscillator, the reactance tube, and the discharge tube, are much the same as in the circuit previously examined. Now, however, the oscillator tuning coil does not form one of the windings of a transformer to furnish a voltage wave for the control circuits. In the circuit which furnishes a varying d-c voltage for the grid of the reactance tube there is a phase detector whose output goes through an interference reducing filter to the reactance grid. The plate of the diode on the input side of the phase detector is coupled to the plate of the sync inverter, which is the last tube in the preceding sync section. The cathode of the diode on the input side of the phase detector is coupled to the cathode of the inverter. Thus, to the plate and cathode on the input side of the phase detector are simultaneously applied sync pulse voltages of opposite polarity. To the center tap between input resistors R_a and R_b is applied a sawtooth voltage wave obtained through coupling from the deflection output or from the horizontal deflection coil.

How the sync pulses and sawtooth waves combine in the input

AUTOMATIC CONTROL OF SWEEP FREQUENCY 251

to the phase detector is shown by Fig. 13-7. Diode *A* is conductive only when its plate is made positive by positive sync pulses from the plate of the inverter, or by the sawtooth, or the combination

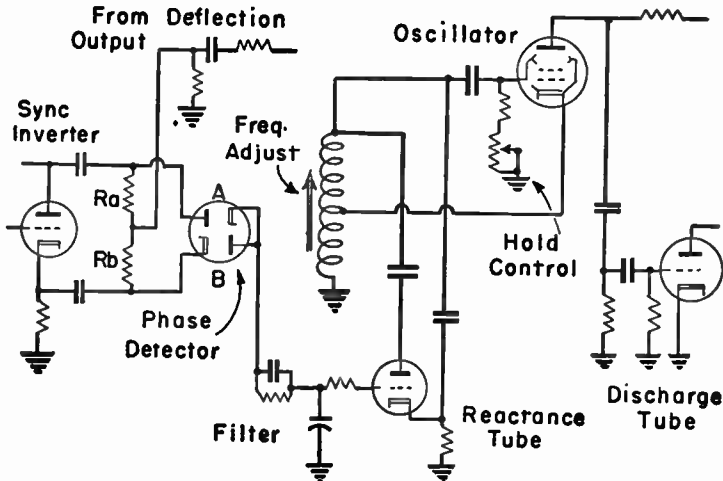

Fig. 13-6.—Horizontal afc system including a phase detector and reactance tube.

of both. Diode *B* is conductive when its cathode is made negative by negative pulses coming from the inverter cathode, or by the sawtooth, or both.

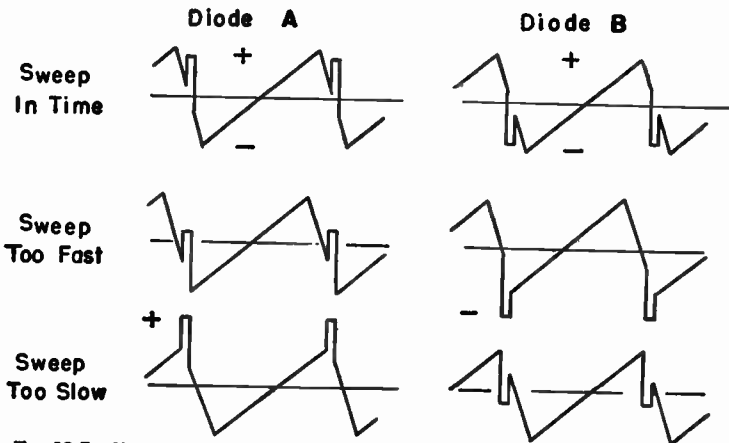

Fig. 13-7.—How sync pulse voltages and a sawtooth voltage from the sweep output combine in the phase detector.

When the sawtooth wave, and deflection at the picture tube, are correctly in time with the horizontal sync pulses the combination voltages are as shown at the top of Fig. 13-7. If the sweep becomes too fast the sync voltages ride down into the sawtooth for diode *A*, but cause decided negative peaks of voltage for diode *B*. If the sweep becomes too slow the sync pulses cause positive voltage peaks for diode *A* and drop into the sawtooth for diode *B*. When sweep frequency deviates from sync frequency in one direction the resulting output from the phase detector makes the reactance tube grid more negative, and with deviation in the opposite direction the reactance grid is made less negative or positive. Then the reactance tube varies the effective inductive reactance of the oscillator circuit to bring the sweep frequency into time with the sync pulses.

The hold control, acting on the oscillator grid, is a front panel control for the operator. The frequency adjustment, which tunes the oscillator coil, is a service adjustment. The Admiral Corporation, which employs this afc control in some receivers, gives the following instructions for adjustment:

1. Set the horizontal hold control all the way counter-clockwise.
2. Turn the horizontal lock (frequency adjustment) clockwise until the pattern falls out of synchronization.
3. Turn the horizontal lock counter-clockwise until the pattern just falls back into synchronization.
4. Set the horizontal hold control fully clockwise and turn the channel selector to the next *higher* channel, then back to the original channel. The pattern should return to synchronization. Should the pattern be broken up, slowly turn the horizontal hold control counter-clockwise until the picture just falls into synchronization. If this control has to be rotated more than 25 per cent to obtain synchronization, look for trouble in tubes of this section, in leaky capacitors, faulty resistors, poor connections, and so on.

Hold Control Action.—The hold control resistors shown on grids of the sine wave oscillators so far considered in this chapter do not act in the same way as hold controls on blocking oscillators and multivibrators discussed earlier. With blocking oscillators and multivibrators giving equivalent results the hold controls are grid leak resistors which determine the time periods

AUTOMATIC CONTROL OF SWEEP FREQUENCY 253

during which the tubes are held non-conductive by negative grid voltage.

In the sine wave oscillators the hold control resistors provide an adjustable negative bias for the tubes. This bias is obtained from a charge which is negative on the side of the grid capacitor toward the grid. The amount of charge and the degree of negative grid bias is varied by the hold control acting as a grid leak. When this bias is sufficiently negative to cause plate current cutoff with negative peaks of oscillator grid voltage we have the effect shown at the left in Fig. 13-8.

Cutting the peaks from one side of the signal in the oscillator plate circuit leaves in this output a sort of square wave, not a sine wave. When this square wave goes through the high-pass

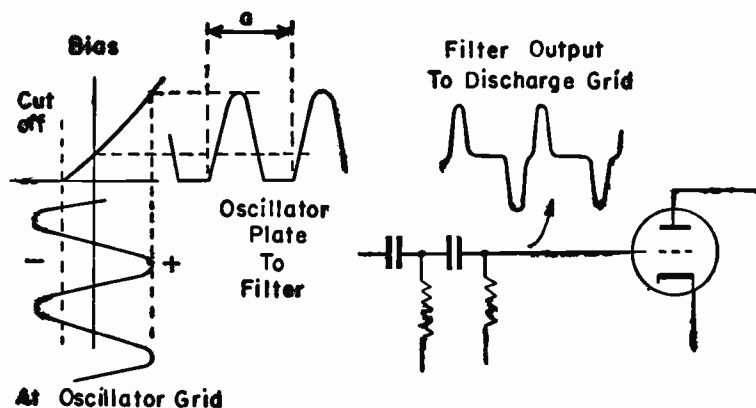

Fig. 13-8.—How the hold control varies the width of square waves from the oscillator, and the time between leading edges of pulses applied to the discharge tube grid.

filter leading to the discharge tube grid the filter output is a series of positive and negative voltage pips. The positive pips make the grid of the discharge tube positive, and this allows discharge of the sawtooth capacitor which is in the plate circuit of the discharge tube.

The more negative the bias at the oscillator grid, as regulated by the hold control, the more of the sine waves is cut off. Then the time between successive corners of the square wave, represented at *a* in Fig. 13-8, becomes longer. This is the same time interval

as between successive positive pulses at the grid of the discharge tube. It is in this manner that the hold control varies the time intervals between successive discharges of the sawtooth capacitor. These waveforms at various points in the control system may be observed with the oscilloscope.

Phase Detector with D-c Amplifier.—The d-c voltages in the output of a phase detector when there is deviation of sweep frequency may be strengthened by a d-c amplifier as shown by

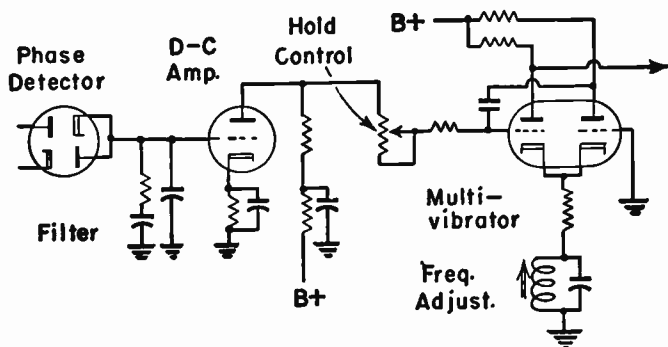

Fig. 13-9.—A d-c amplifier between the output of a phase detector and the grid of a sweep oscillator.

Fig. 13-9. The output of the d-c amplifier is applied here to a multivibrator sweep oscillator. When voltage on one of the grids of such an oscillator becomes more or less positive there are accompanying changes of oscillator frequency. The hold control, in series between phase detector and amplifier, varies the voltage reaching the amplifier grid.

In the cathode circuit of the multivibrator is a parallel resonant circuit whose frequency may be tuned to control the oscillator frequency. This is a service adjustment, while the hold control is for the operator. With the hold control set at the center of its range, the cathode frequency adjustment is tuned to give the best possible conditions of horizontal hold-in and pull-in. These conditions have been described in connection with other controls.

Phase Detector to Multivibrator.—Fig. 13-10 shows a horizontal afc circuit in which the d-c output of a phase detector is applied directly to one of the grids of a multivibrator sweep oscillator. One plate and one cathode of the detector are coupled respectively to the plate and cathode of a sync inverter, the last tube in the

AUTOMATIC CONTROL OF SWEEP FREQUENCY 255

sync section. The inverter delivers positive sync pulses to the detector plate, and negative sync pulses to the detector cathode. The other cathode and other plate of the detector are connected together, and to them is applied a sawtooth voltage secured from the sweep output circuits.

The sawtooth voltage on both diodes and the positive and negative sync voltages combine in the manner illustrated by Fig. 13-7. When the sweep output is correctly in time with the sync signals the voltage at the tap between resistors R_a and R_b is zero. When the sweep sawtooth varies there is an increase of peak-to-peak

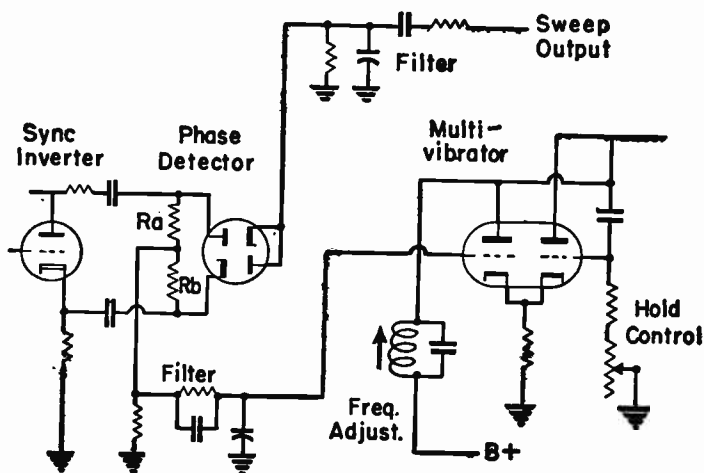

Fig. 13-10.—A phase detector output coupled to one of the grids of a multivibrator sweep oscillator.

voltage on one diode and a decrease on the other, there are unbalanced voltages in the two resistors, and a positive or negative voltage is applied to the grid of the multivibrator, depending on the direction of frequency deviation. Varying the voltage at this grid changes the multivibrator frequency and the resulting frequency of the sweep to bring the sweep into time with the sync pulses.

In the plate circuit of the left-hand multivibrator is a tuned resonant circuit which is a service adjustment for oscillator frequency. Adjustment is made as follows:

1. Tune in a transmitted signal, preferably one carrying a test pattern.

2. Set the hold control, a front panel adjustment, at the center of its adjustment range.

3. If the pattern does not lock in, adjust the slug of the frequency control coil until it does so.

4. Rotate the hold control all the way clockwise, then turn it slowly back counter-clockwise. Three or four sloping black bars should appear just before the pattern locks in.

5. Rotate the hold control all the way counter-clockwise, then slowly back. Again there should appear three or four sloping black bars just before lock-in. The pattern may drop out of synchronization at both ends of the hold control range without indicating need for adjustment. If the conditions of this step are not satisfied, readjust the frequency control until they are.

Oscillator Bias for Afc.—Fig. 13-11 shows a circuit with which the grid bias of a blocking oscillator is automatically varied to provide control of horizontal sweep frequency. There is oscillation feedback from plate to grid of the oscillator through the control coil shown above the oscillator tube. Output to the sweep amplifier is from the center tap of this coil. During normal operation of the oscillator there is produced a strongly negative grid

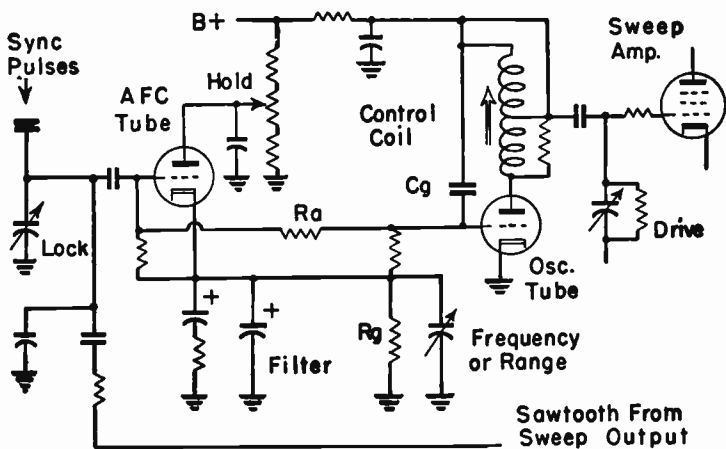

Fig. 13-11.—Horizontal afc system in which the control varies grid bias of the oscillator.

AUTOMATIC CONTROL OF SWEEP FREQUENCY 257

bias by action of grid capacitor C_g and grid resistor R_g , as is the case with any blocking oscillator. This highly negative bias is applied also to the grid of the afc tube through resistor R_a .

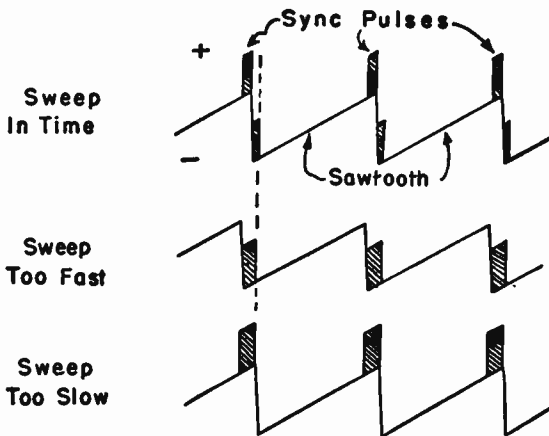

Fig. 13-12.—How the duration of sync pulse voltages is varied by combining the sync and sawtooth voltages in the afc triode.

To the grid of the afc tube come also two other voltages. One consists of the positive sync pulses from the connection at the upper left which is the output of the sync section. The other voltage on the afc grid is a sawtooth wave from the sweep output, brought by way of the connection at the lower right. Combinations of the two voltages are shown by Fig. 13-12. When the sawtooth voltage from the sweep output is correctly in time with the sync pulse voltages about half of each pulse rides on the sawtooth peak and other half is down in the trough between peaks. While the pulse is on top of the peak the combined positive voltages are great enough to make the afc tube conductive. These combined voltages overcome the negative bias coming from the oscillator grid circuit. Conduction in the afc tube then lasts for about half the duration of each sync pulse voltage.

If the sweep is too fast more of the sync voltages drop into the trough, or maybe all of each pulse drops thus. Then there never is voltage sufficiently positive to make the afc tube conductive. On the other hand, if the sweep is too slow, all or nearly all of every sync voltage will ride on the sawtooth peak. Then the afc

tube will conduct during periods as long as the periods of the sync pulse voltages.

Every period of conduction in the afc tube charges the two capacitors of the filter in Fig. 13-11, with the upper plates of these capacitors made positive. The greater the total conduction per second in the afc tube the greater is the charge put on these filter capacitors. Positive voltage resulting from capacitor charges counteracts more or less of the negative voltage produced across resistor R_g by the oscillator, this being the negative grid bias for the oscillator.

Thus it comes about that the slower the sweep tends to become, the greater is the charging of the filter capacitors and the less negative becomes the voltage at the oscillator grid. The less negative the voltage at the grid of a blocking oscillator the higher becomes the oscillation frequency. Thus a slowing down of the sweep results in a speedup of oscillator frequency to make the necessary correction.

Fig. 13-13 shows the general form of oscilloscope traces taken in this particular type of horizontal afc system. At the left is the input to the grid of the afc tube. This trace results from the action

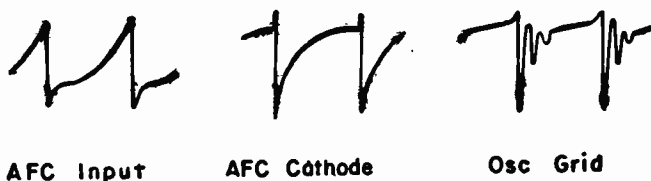

Fig. 13-13.—Oscilloscope traces from the horizontal afc system employing a voltage-combining triode.

illustrated by Fig. 13-12. The center trace, from the cathode of the afc tube, shows quite clearly the positive voltage pips that charge the filter capacitors. At the right is a trace from the oscillator grid. A somewhat similar trace, showing oscillations of voltage, may be had from the plate of the oscillator.

There are four adjustments in this horizontal afc system. The hold control, a front panel adjustment for the operator, varies the voltage at the plate of the afc tube and thus varies the strength of charging pulses put into the filter capacitors when there is frequency deviation. This control will vary the oscillator

AUTOMATIC CONTROL OF SWEEP FREQUENCY 259

frequency by about five per cent. The remaining controls are service adjustments. The lock control acts as a bypass capacitor to vary the amplitude of the sawtooth waves at the afc grid. The range control is in parallel with the filter capacitors to vary the effective filter capacitance and charge voltage. The adjustable slug in the control coil tunes the oscillator grid-plate circuit.

The following adjustment instructions are given by Philco Corporation, which employs this method of horizontal afc in some models.

1. Make the following preliminary settings.
 - a. Frequency trimmer capacitor $1\frac{1}{2}$ turns counter-clockwise from the maximum clockwise position.
 - b. Drive trimmer (in grid circuit of sweep amplifier) 2 turns counter-clockwise from maximum clockwise position.
 - c. Lock trimmer $\frac{1}{2}$ turn counter-clockwise from maximum clockwise position.
 - d. Horizontal hold control to approximate center of its range.
2. Tune in a station, and adjust the slug of the control coil until the picture is brought into sync. (In some receivers this slug is called the frequency adjustment.)
3. Adjust the contrast control for normal contrast.
4. Turn the horizontal hold control fully clockwise.
5. Adjust the slug of the control coil until 8 to 10 stationary blanking bars appear, sloping downward from the left side of the picture tube. If this cannot be accomplished, turn the frequency trimmer capacitor another full turn counter-clockwise, and repeat this step.
6. Turn the horizontal hold control counter-clockwise until the picture is brought into sync; continue to rotate this control until the picture falls out of sync. In some cases the picture will not go out of sync, even though the horizontal hold control is turned to its extreme counter-clockwise position. If this is the case, momentarily short the antenna terminals. When the short is removed the picture will be out of sync.
7. Slowly turn the horizontal hold control clockwise, and note the change in number of blanking bars appearing on the picture tube. The number of bars should decrease as sync is approached.

Just before the picture falls into sync, there should be $3\frac{1}{2}$ to $4\frac{1}{2}$ bars sloping upward from the left side of the picture tube.

8. If there are more than $4\frac{1}{2}$ bars, turn the lock control capacitor another $\frac{1}{4}$ turn clockwise, and repeat steps 4 through 8. If there are fewer than $3\frac{1}{2}$ bars, turn the lock control capacitor another $\frac{1}{4}$ turn counter-clockwise, and repeat steps 4 through 8.

Afc Diode for Oscillator Bias.—Fig. 13-14 shows a horizontal afc system in which a diode coupled to the output of the sync section is used to vary the bias and the frequency of a blocking oscillator. The following explanation is adapted from literature of Motorola, Inc., in some of whose receivers this method is employed.

Capacitor C_a , across the primary of the afc transformer, changes the sync pulse to an a-c wave which is coupled to the plate of the afc diode through the transformer secondary. Resistor R_a damps the secondary. There is a small negative sawtooth across capacitor C_b , but this does not materially affect the operation. Resistor R_b , in series with capacitor C_c , form a network which differentiates the horizontal sawtooth of the cathode sweep voltage on capacitor C_d , producing a negative retrace pulse which is fed to the cathode of the afc diode.

Note that here we are obtaining from the oscillator output, on its cathode side, a voltage pulse derived from the steeply sloped

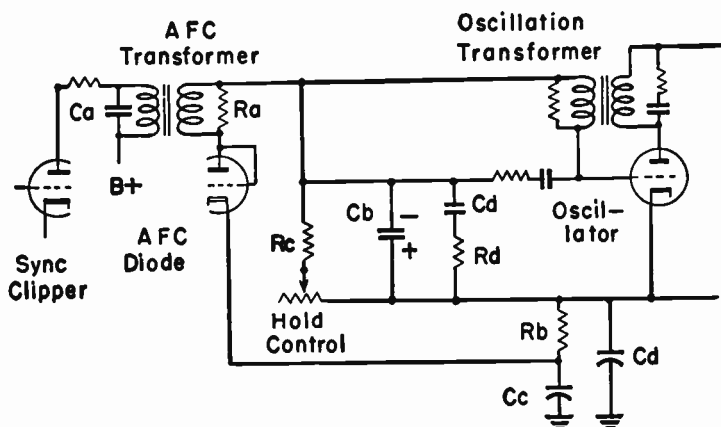

Fig. 13-14.—Horizontal afc system employing a diode-connected triode for varying the oscillator grid voltage.

AUTOMATIC CONTROL OF SWEEP FREQUENCY 261

side of the sawtooth wave which occurs upon discharge of the sawtooth capacitor. Then the timing of the voltage pulse going back to the cathode of the afc diode is the timing of the sweep which is acting on the picture tube. At the same time we have obtained from the sync section an a-c wave, approximately a sine wave, whose timing corresponds to the horizontal sync frequency of the received signal. This is the reverse of some other systems which have been examined, wherein a voltage pulse is obtained from the sync section, and either a sine wave or a sawtooth wave is brought back from the oscillator or the sweep output.

How the two voltages combine is illustrated by Fig. 13-15. When the sweep is correctly in time with the sync signal the sweep pulse rides midway up the positive amplitude of the sync wave. When the sweep is slower than the sync the sweep pulse rides higher, becomes more positive, and when the sweep is fast

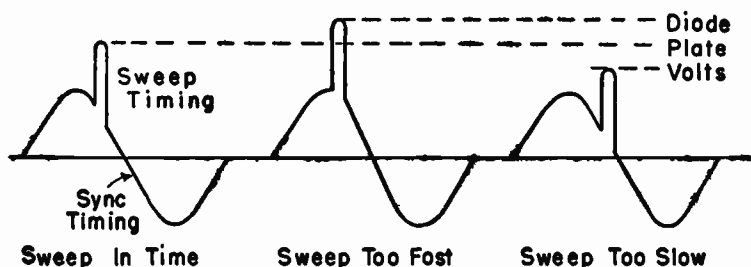

Fig. 13-15.—How pulses representing sweep timing, and a sine wave representing sync timing, are combined in the afc diode.

the pulse rises lower, becomes less positive. The combination becomes positive because the negative retrace pulse on the cathode of the afc diode is equivalent to a positive pulse on the plate.

When the sweep is fast, and the pulse becomes more positive, the afc diode forces more current through resistor R_c and the hold control resistance. More current increases the voltage drop, increases the bias on the oscillator grid, and slows down the oscillator frequency. If the sweep becomes too slow, the pulse becomes less negative and the afc diode forces less current through resistor R_c and the hold control. This decreases the

oscillator grid bias and tends to speed up the oscillator frequency. These two actions change the charge and the voltage across capacitor C_b , which is in parallel with resistor R_c and the hold control. Capacitor C_d and resistor R_d have a time constant long enough to hold the horizontal sweep in synchronization through a period of 20 to 50 lines.

We have examined enough horizontal afc systems to bring out a fundamental principle common to all of them, and to others which have not been discussed. Always there is an electrical comparison of the horizontal sync frequency, coming from the sync section, with the actual horizontal sweep frequency as derived from the horizontal oscillator or from sweep circuits which are between oscillator and picture tube deflection plates or coils. The comparison or combination of pulses and waves always produces in some manner a voltage which acts directly or through other tubes on some characteristic of the oscillator which alters the oscillation frequency in a direction which corrects or compensates for the change of sweep frequency

Chapter 14

SWEEP AMPLIFIER AND DEFLECTION CIRCUITS

The sweep amplifier and deflection circuits extend from the output of the sweep oscillator or discharge tube all the way through to the deflection plates of electrostatic picture tubes or to the deflection coils of magnetic picture tubes. There are decided differences between circuits for electrostatic and magnetic deflection, and, especially with magnetic deflection, there are great differences between circuits for vertical and horizontal systems.

Electrostatic Deflection Amplifiers.—Basic features found in amplifiers for electrostatic deflection are shown by Fig. 14-1. The circuit is very similar to push-pull resistance-capacitance coupled audio output circuits found in many receivers for sound radio.

The sawtooth voltage produced in the sawtooth capacitor by action of the sweep oscillator or discharge tube is applied to the grid of amplifier A. The plate output of this tube is applied through coupling capacitor C_a to one of the vertical deflection plates or one of the horizontal deflection plates of the picture

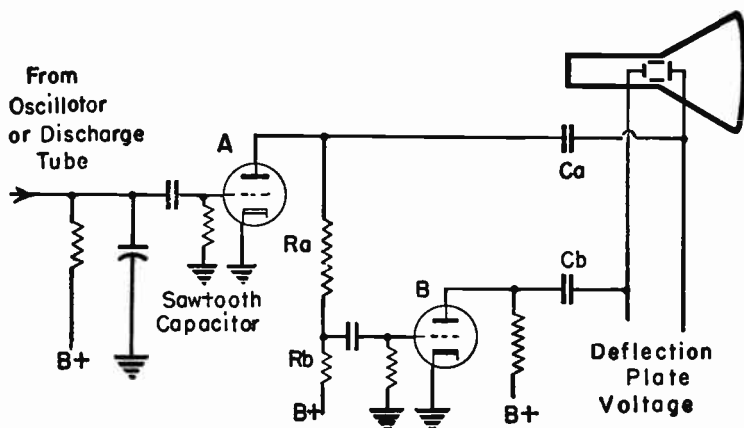

Fig. 14-1.—An electrostatic deflection amplifier circuit.

tube, depending on whether we consider the vertical or horizontal deflection system.

The output of amplifier *A* is coupled also to the grid of amplifier *B*, and the plate output of amplifier *B* is coupled through capacitor *Cb* to the other vertical or horizontal plate of the picture tube. The voltage applied to the grid of tube *B* is amplified by this tube. Were the full output voltage of amplifier *A* applied to the grid of *B* the deflection voltage applied to the picture tube from *B* would be much greater than from tube *A*. To reduce the output of tube *B* to the level of that from tube *A*, the grid of *B* is fed from a point low down in the voltage divider formed by resistors *Ra* and *Rb*. The ratio of voltage across the entire divider to the voltage across section *Rb* is the same as the ratio of gain in amplifier *B*.

There may be many modifications of this circuit without affecting the general principle of equalizing the amplifier outputs. For example, in Fig. 14-2 the voltage divider feeding amplifier *B* consists of capacitor *Ca* in series with resistor *Rb*. Since the B+

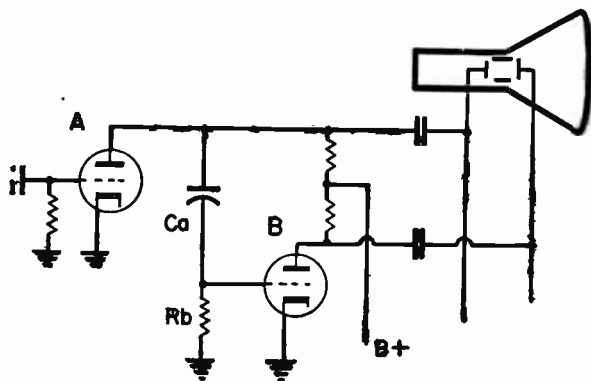

Fig. 14-2.—Capacitor coupling to the inverter for electrostatic deflection.

voltage for tube *A* cannot now be taken through the voltage divider capacitor it is moved over to the same point as the B+ connection for tube *B*. Instead of using the resistors shown between B+ and the tube plates, the impedances in series with B+ may be chokes, or some combination of resistors and chokes.

The inversions of sawtooth polarity are shown by Fig. 14-3. At 1 is the voltage wave from the sawtooth capacitor as it charges

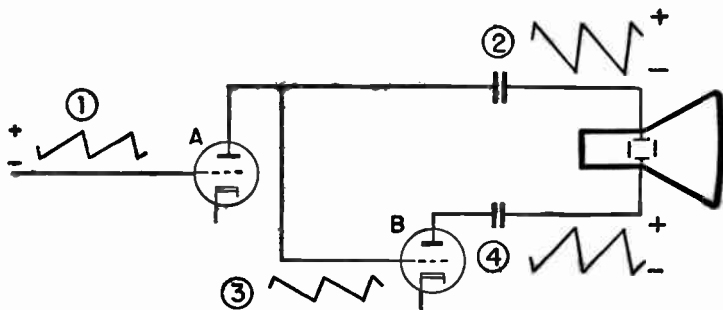

Fig. 14-3.—Inversions of sawtooth polarity between oscillator and picture tube for electrostatic deflection.

and discharges. This wave is inverted between grid and plate of tube A, and appears on one of the electrostatic deflection plates as at 2. The inverted wave is applied to the grid of tube B as shown at 3. The wave is inverted in this tube and reaches the other deflection plate as at 4. Thus each deflection plate becomes more positive as the opposite plate of the same pair becomes more negative, and vice versa, as required for deflection of the electron beam.

In Fig. 14-4 there is only a single sweep amplifier, with the necessary inversion of sawtooth wave polarity obtained by taking the voltages from opposite ends of a center-tapped auto-transformer fed from the amplifier plate. When employing a transformer for sweep output there is a tendency toward deformation of the voltage waves applied to the picture tube. This

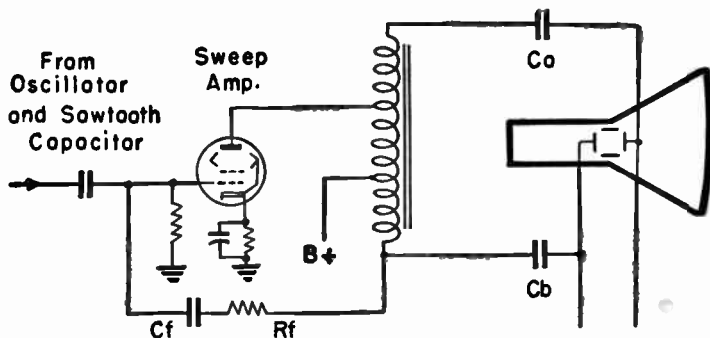

Fig. 14-4.—Vertical electrostatic deflection with a single amplifier.

is corrected by the feedback from output to amplifier grid through capacitor C_f and resistor R_f .

In Fig. 14-5 there is no sweep amplifier, the blocking oscillator is coupled directly to the deflection plates of the picture tube. The required inversion of sawtooth waves at the picture tube is obtained by taking one of these voltages from the oscillator plate, through the oscillation transformer, and taking the other voltage from the oscillator cathode. The cathode wave is of the same polarity as that on the oscillator grid, while the plate wave is inverted with respect to grid and cathode waves.

The double choke connected across this deflection circuit permits a connection from the oscillator plate line through the size control to B+, but prevents discharge of the sawtooth capacitor through this path while the oscillator tube is conductive. The

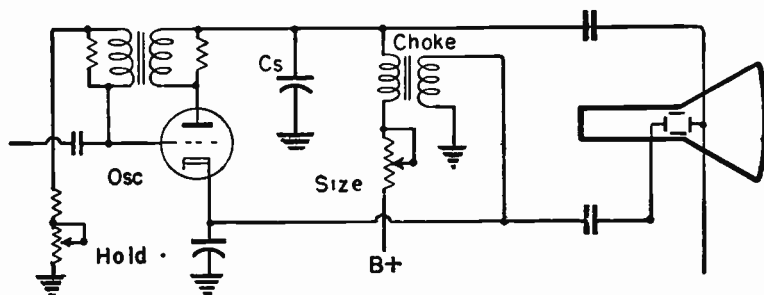

Fig. 14-5.—Electrostatic deflection system employing no amplifier.

very sudden change of current in the choke causes such a high counter-emf as to effectively impede the current. The choke acts like any large inductance, in having high impedance to a large alternating current or to any sudden change of current in the winding.

Waveforms observed with the oscilloscope connected to various points in an electrostatic deflection system will show sawtooth voltages essentially as illustrated by Fig. 14-3. At opposite plates of either pair in the picture tube must be waves of opposite or inverted polarity. Because of the very high voltages at the tube itself, these waveforms should be taken only from the plates of the deflection amplifiers, or from the tube side of the capacitors which couple the deflection voltages into the picture tube plates.

SWEEP AMPLIFIER AND DEFLECTION CIRCUITS 267

There will be inversion of wave polarity when shifting the scope from grid to plate of any tube in the system, but no inversion when shifting from grid to cathode of the same tube. Waves at plate and cathode of the same tube will be of opposite polarity. Irregular waveforms observed at some points in a system may be corrected at points closer to the picture tube plates. Sometimes the irregularities are due to poor frequency response of the scope when working at horizontal deflection frequencies.

Magnetic Deflection Amplifiers.—In a number of receivers employing magnetic deflection for the picture tube we find a vertical sweep system such as shown by Fig. 14-6. These circuits extend from the plate of the vertical oscillator or discharge tube through to the vertical deflection coils which are part of the deflection yoke on the neck of the picture tube.

The vertical amplifier tube may be a power triode, or a power pentode, or it may be a pentode or a beam power tube connected with plate and screen together to act as a triode. The height control resistor in the B+ lead to oscillator or discharge tube, also the sawtooth capacitor C_s and negative peaking resistor R_s have been described earlier. You will recall that the purpose of resistor R_s is to so retard the discharge of the sawtooth capacitor as to produce a negative square pulse at the beginning of the sawtooth charge period, thus producing the waveform required to induce a sawtooth current in magnetic deflection coils.

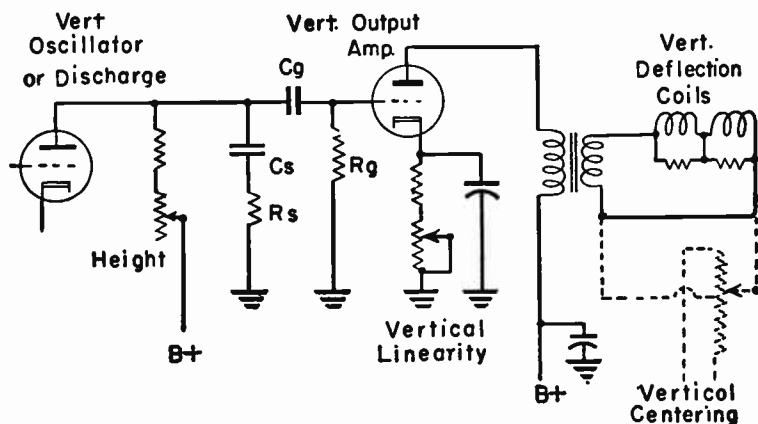

Fig. 14-6.—A vertical output amplifier circuit for magnetic deflection.

The sweep amplifier is biased by grid rectification with grid capacitor C_g and grid resistor or leak R_g , also by cathode bias resulting from resistors between cathode and ground or B—. The cathode bias is adjustable. It is called a vertical linearity control because, when correctly adjusted, it helps distribute the picture uniformly from top to bottom of the screen. This and other linearity controls will be discussed a little later.

The plate circuit of the output amplifier includes the primary of the vertical output transformer. In the secondary circuit of this transformer are the two halves of the vertical deflection coils. Across each coil is shunted a resistor which prevents oscillating currents from being set up by inductance and capacitance in the coil circuit.

In some receivers there is a vertical centering control such as shown by broken lines. The resistor of this control carries direct current and has a d-c voltage drop across it. Adjustment of the slider causes a direct current to flow in the deflection coils, in addition to the sawtooth deflection current. The electron beam is deflected farther toward the top or farther toward the bottom to raise or lower the picture on the screen. The direction depends on which way the direct current flows through the coils. Vertical centering is accomplished in other receivers by tilting the focus coil with reference to the axis through the neck of the picture tube.

The circuit shown at the left in Fig. 14-7 is in general use for vertical sweep amplifiers. It differs from the previous circuit in that the low end of peaking resistor R_s is connected to the amplifier cathode rather than to ground. This puts the discharge current from sawtooth capacitor C_s through the cathode bias resistors of the amplifier. The result is to produce, during the discharge period, a large current and voltage drop in the bias resistors. This makes the amplifier grid highly negative with reference to its cathode during the discharge period. This is the negative voltage which appears in the square pulse preceding the sawtooth portion of the grid signal. The time constant which determines how much charge is held on the sawtooth capacitor now is affected not only by R_s but by the effective resistance between cathode and ground.

Still another vertical amplifier circuit is shown at the right in

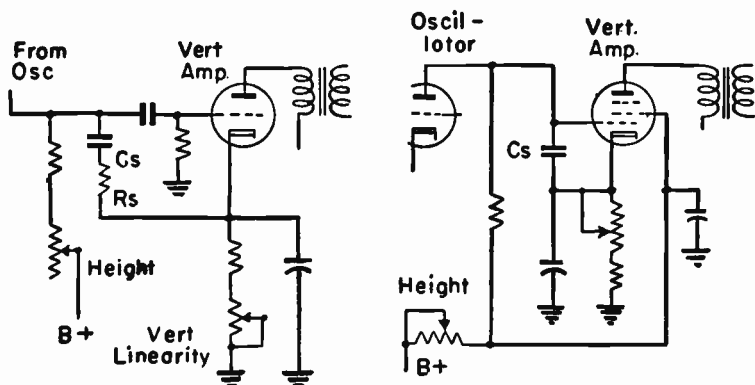

Fig. 14-7.—Circuits for sawtooth capacitors in vertical amplifier systems for magnetic deflection.

Fig. 14-7. Here the oscillator plate and amplifier grid are conductively connected and operate at the same average voltage. All the resistance between the negative side of the discharge capacitor and ground is in the cathode resistors of the amplifier.

In all vertical amplifier circuits which have been illustrated the capacitance of the bypass across the cathode resistors is very large. The value usually is something between 10 and 150 microfarads.

Oscilloscope traces taken from any of the vertical amplifiers whose circuits have been shown should have the general appearance of Fig. 14-8. The negative square pulses on the grid reappear on the plate as sharp positive pulses. The gradual sawtooth slope between pulses will not always be straight, as shown, but may have some curvature either upward or downward. The depth or height of the negative and positive pulses, in comparison with the height of the sawtooth portion of the wave, will vary with changes in settings of various controls, but this will not alter the characteristic form of the traces.

Height controls in the preceding circuit diagrams for vertical output amplifiers have been shown as adjustable resistors in series with the B-supply to the oscillator or discharge tube. This control was discussed earlier in connection with oscillators. It is quite generally used for receivers having either electrostatic or magnetic deflection picture tubes. The same type of control is

found also in the circuits of horizontal oscillators and sweep amplifiers, then being a width control. As $B+$ voltage for charging the sawtooth capacitor is increased by reduction of control resistance, the effect is to increase the height of the sawtooth portion of the wave. It is the height or amplitude of the sawtooth wave which determines how far the picture tube beam travels vertically or horizontally when other factors remain unchanged.

Defective Interlacing.—The active lines or horizontal traces for one field are supposed to be spaced midway between lines of preceding and following fields. This is called interlaced scanning. If the lines of the two fields overlap or coincide evenly over the whole screen area there will be a very coarse pattern vertically,

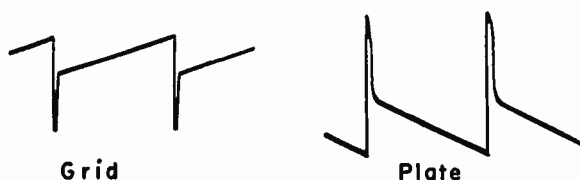

Fig. 14-8.—Oscilloscope traces from a vertical amplifier for magnetic deflection.

for there will be only half the correct number of lines. Sometimes there will be tiny white beads on some horizontal lines, and if the edge of the picture is examined it may appear jagged or stepped. If interlacing is farther out at the center or near the center than at the top and bottom, there will be white horizontal streaks across the picture. The usual cause for defective interlacing is a faulty vertical sweep amplifier tube. The remedy is replacement with another tube.

Horizontal Amplifiers for Magnetic Deflection.—So many things happen at the same time between the output from the sweep oscillator or discharge tube and the horizontal deflection coils that it is difficult to discuss any one feature without having to mention others. For this reason we may look first at Fig. 14-9 where are shown in rather simple form many of the details found in a great many horizontal output systems.

At the left is the connection from the preceding horizontal oscillator or discharge tube, to which are connected the $B+$ lead and the sawtooth capacitor C_s . Doubtless you note that there is in series with the sawtooth capacitor no resistance to delay the dis-

SWEEP AMPLIFIER AND DEFLECTION CIRCUITS 271

charge and cause formation of a negative square pulse preceding the sawtooth voltage. It has been explained earlier that such a combination wave of voltage, applied to deflection coils, produces a plain sawtooth current in spite of the high inductive reactance of the coils. In the circuit illustrated the deflection coil reactance is made rather small, and the output amplifier is a beam power type (6BG6-G) having high plate resistance. Then in the entire plate circuit, including the transformer and deflection coils, the resistance is enough greater than the coil reactance to allow a sawtooth voltage wave to produce a sawtooth coil current for deflection. In other circuits to be shown there will be a negative-peaking resistor on the sawtooth capacitor lead, but the resistor is not absolutely necessary when the deflection circuits are designed to work without it.

Connected to the upper parts of the transformer windings is a high-voltage half-wave rectifier tube which furnishes a potential of 8,000 volts or more for the high-voltage anode of the picture tube. The windings and rectifier form part of a "flyback" high-voltage supply which will be examined later.

Shunted across the lower end of the main secondary winding

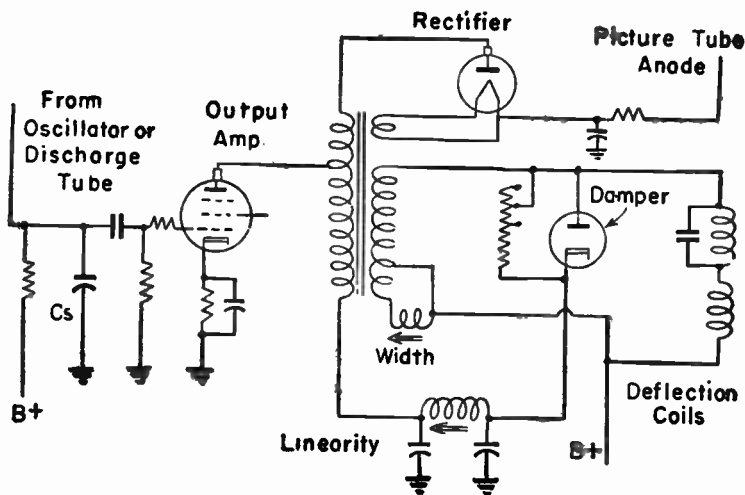

Fig. 14.9.—Typical connections between a horizontal sweep oscillator and horizontal deflection coils.

the transformer is an adjustable inductor forming a width control. Adjustment of the powdered iron core in this unit varies the effective secondary inductance of the transformer, varies the output voltage and resulting deflection coil current, and thus varies the horizontal distance traveled by the beam in the picture tube.

Connected into the deflection coil circuit is a diode tube called a damper. Its chief purpose is to prevent oscillation in the coil circuit at a frequency corresponding to circuit inductance and capacitance. During the first cycle of such oscillation the damper tube conducts so heavily when its plate becomes positive that no additional cycles can occur. The energy represented in pulses of damper current is not wasted, but is added to energy taken from the B-supply and used to increase the voltage applied through the transformer primary to the plate of the output amplifier tube.

Between the damper cathode the amplifier plate, by way of the transformer primary, is another adjustable inductor which is a control for horizontal linearity or for helping to obtain uniform and correct distribution of picture elements from left to right on the screen.

Now that we know in a general way the purposes and electrical locations of some parts which are common to many deflection circuits we may proceed to consider the important details.

Resistance Control for Peaking or Drive.—In Fig. 14-10 we have in series with the sawtooth capacitor an adjustable resistor which connects through the amplifier cathode resistor R_k to ground. The resistance between the negative side of the sawtooth capacitor and ground delays the capacitor discharge and produces the negative square pulse with which we are familiar.

The adjustable resistor in this position most often is called a drive control, although sometimes it is called a linearity control, and again a peaking control. The greater the resistance placed in the circuit the more charge will remain on the sawtooth capacitor at the end of discharge. This changes the depth or length of the negative square pulse. Since this length is subtracted from the overall amplitude of the wave, adjustment of the control also changes the height of the sawtooth portion of the wave. The height of the sawtooth portion of the voltage wave determines the horizontal distance traveled by the picture tube beam, and,

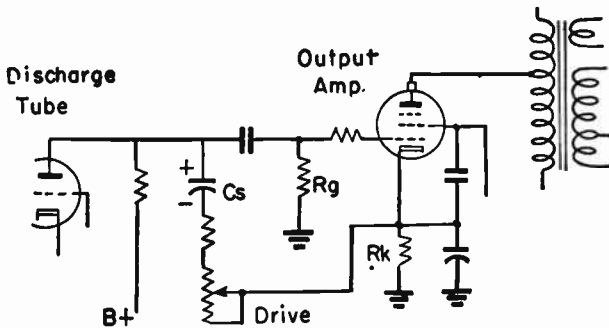

Fig. 14-10.—An adjustable resistor as drive control.

as a consequence, this drive control alters the width of the picture. In a few receivers it is the only control for width.

Fig. 14-11 shows the effects of changing the resistance of this drive control, as the effects are observed with an oscilloscope connected to the amplifier control grid circuit or the discharge tube output. With the least possible adjustable resistance in circuit the negative pulses will be short and the sawtooth wave will be high, as at the left. The effect of a medium amount of control resistance is shown at the center. At the right, with maximum possible adjustable resistance in circuit, the negative peaks are deep and there is relatively little rise in the sawtooth portion of the wave. Adjustment changes the discharge time constant, the ratio of heights of square pulse to sawtooth, and the strength of the square pulses which insure a sawtooth current in the deflection coils.

Pulses of current in the amplifier plate circuit begin only when the sawtooth voltage becomes sufficiently positive to overcome the negative bias of the amplifier grid. This alters the point in the cycles at which conduction begins, and linearity of the picture is affected.



Fig. 14-11.—Oscilloscope traces showing the effects of varying the resistance in a drive control.

The drive control here considered affects the sides of the picture or pattern more than the center. Misadjustment will stretch out the left and crowd the right side of the picture or pattern, somewhat as represented by Fig. 14-12.

In making an adjustment the drive control should be turned to provide as much series resistance as does not cause crowding on the right, or so that the right and left sides are symmetrical, equally disposed with reference to the center. Altering the drive control will require readjustment of the width control to have

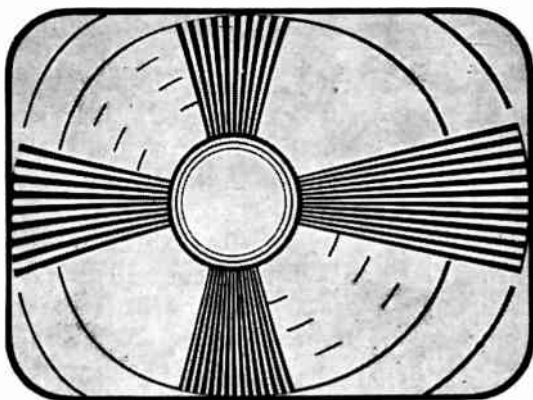

Fig. 14-12.—How misadjustment of a drive control affects the pattern.

the picture just fill the mask opening horizontally. It may be necessary also to adjust the linearity control shown in Fig. 14-9 to make the picture symmetrical. The drive, width, and linearity controls affect one another, and have to be adjusted together.

Capacitor Drive Control.—In Fig. 14-13 we have a drive control consisting of an adjustable capacitor rather than an adjustable resistor, and utilizing quite different principles. The adjustable drive capacitor and grid capacitor C_g are in series with each other, and the two are in parallel across sawtooth capacitor C_s . Then the drive trimmer and capacitor C_g form an adjustable voltage divider of the capacitance type, with a center connection to the grid of the output amplifier.

Voltage applied to the grid is some fraction of the voltage developed across the sawtooth capacitor. This fraction is the ratio of the capacitive reactance in the drive trimmer to the total

SWEEP AMPLIFIER AND DEFLECTION CIRCUITS 275

capacitive reactance of C_g and the trimmer in series. The less the capacitance in the drive trimmer the greater is its capacitive reactance, and the greater is the voltage applied to the amplifier grid. We increase the drive by reducing the trimmer capacitance. The waveform of voltage applied to the grid is the sawtooth wave developed on the sawtooth capacitor.

This type drive control changes the width of the picture because of changing the amplitude of the sawtooth wave. When the capacitor drive control is used in connection with the flyback high-voltage supply of Fig. 14-9, adjustment of the drive changes the

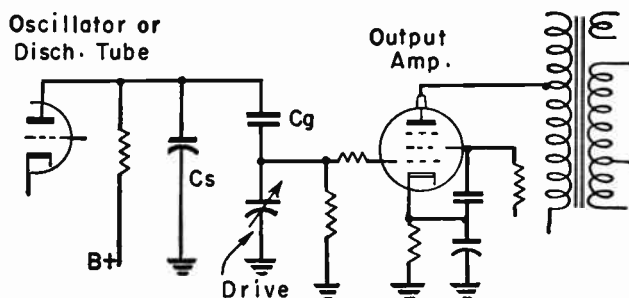

Fig. 14-13.—An adjustable capacitor as a drive control.

strength of pulses going to the high-voltage rectifier, changes the voltage at the anode of the picture tube, and varies the brightness of the picture.

Drive adjustment affects also the linearity. It will shift either or both sides of the picture, stretching the left side and crowding the right side when there is too much drive. Incorrect adjustment can cause fold-over, apparent from a light or white vertical streak at the left or toward the center of the picture area.

When adjusting this type of drive control the first step, if it is necessary, is to set the width control on the transformer secondary for a picture or pattern of approximately the correct width. Then the drive is adjusted for the least capacitance which does not destroy linearity by crowding at the right side. Too much drive capacitance will make the picture or pattern too narrow and will cause a great reduction of brightness and of definition or clarity. The best adjustment for the drive control is one which allows the brightest picture which still shows good definition and satisfac-

tory linearity. Often it is necessary to readjust the horizontal linearity by means of the inductor shown in Fig. 14-9.

With some capacitor type drive controls it is possible to reduce the capacitance and increase the sawtooth amplitude so far as to produce at the picture tube anode a voltage higher than the maximum rating for this tube. This danger usually exists in some systems wherein the drive control includes a feedback of peaking voltage from the secondary circuit of the transformer or from the deflection coil circuit. If, however, adjustment of the drive control seems to be causing abnormal brightness on the picture tube screen, this adjustment should be carried out only while a voltmeter suitable for measuring up to 10,000 volts or more is connected to the picture tube anode lead.

Fig. 14-14 illustrates waveforms such as may be obtained with the oscilloscope connected to the amplifier control grid or to the



Fig. 14-14.—Oscilloscope traces from the grid of an output amplifier with which is used a capacitor drive control.

high side of the drive capacitor. Different receivers give slightly different traces.

In many receivers employing a capacitor type drive control there is a feedback of voltage pulses from the deflection coil circuit for the purpose of producing a negative peak preceding the sawtooth wave applied to the grid of the output amplifier. One method of feedback is illustrated by Fig. 14-15. Here there is a connection from the deflection coil circuit through a series resistor and capacitor to the grid circuit of the amplifier, either just ahead of or just following the grid capacitor C_g . The series resistor usually is on the order of a half-megohm resistance, and the series capacitor ordinarily is of less than 15 mmfd capacitance. These impedances are high enough that the feedback voltage is too small to cause overloading of the picture tube anode by excessive anode voltage, even with misadjustment of the drive control.

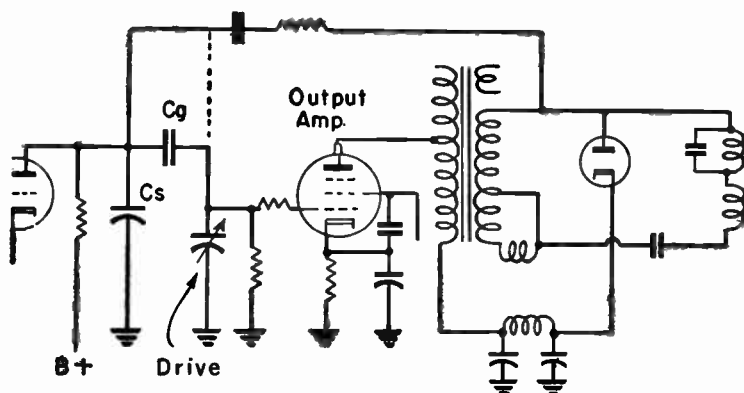

Fig. 14-15.—Feedback from deflection coil circuit, for producing negative pulses ahead of the sawtooth waves.

When there is feedback producing negative pulses preceding each sawtooth, oscilloscope traces taken at the grid of the output amplifier will show these pulses quite clearly. At the left in Fig. 14-16 is the general appearance of a trace secured with all adjustments set for normal operation. Increasing the capacitance of the drive control capacitor, to lessen its reactance, will cause changes about as illustrated at the center and right. There is reduction of the sawtooth height and also of the pulse height. In spite of the fact that drive adjustment does not directly affect the feedback, the pulses become smaller and smaller percentages of total amplitude as drive capacitance is decreased.

As with other capacitor drive controls, increase of capacitance results in a narrowing of the picture because of less height in the sawtooth portions of the wave. Brightness decreases because the lessened overall amplitude results in less voltage at the anode of the picture tube. Too much drive capacitance will make the picture too narrow, too dim, and very fuzzy in details.



Fig. 14-16.—Oscilloscope traces showing the effect of adjusting a drive capacitor when there is feedback for production of negative pulses.

Amplifier Plate Voltage.—With a flyback high-voltage system such as shown in preceding circuit diagrams there should be no attempt at voltage measurements at the amplifier plate without special equipment. Although the average plate voltage is not too high, there are pulses at the horizontal frequency which reach maximum potentials of 4,000 to 6,000 volts with reference to ground or to B—. Neither should there be any attempt to connect the oscilloscope to the amplifier plate except through some voltage divider system designed for such work.

Width Control on Transformer.—With a width control as shown by Fig. 14-9 we have an adjustable inductance in parallel with part of the inductance in the secondary winding of the transformer. When two inductances are in parallel their combined inductance is less than that of either one alone. It follows that connection of the width control to the secondary reduces the secondary inductance. There would be greater voltage from the secondary, and greater current in the deflection coils with the width control inductor disconnected than with it connected to the secondary. It is a fact that maximum possible coil current and width of picture is obtained by disconnecting one end of the width control.

But so long as the width control is connected across part of the secondary winding, increasing the inductance of the width control unit causes an increase of combined inductance of the unit and its end of the secondary. Increasing the combined inductance increases the total secondary inductance, increases the voltage and coil current, and increases picture width. Consequently, to increase the picture width, turn the core of the width control

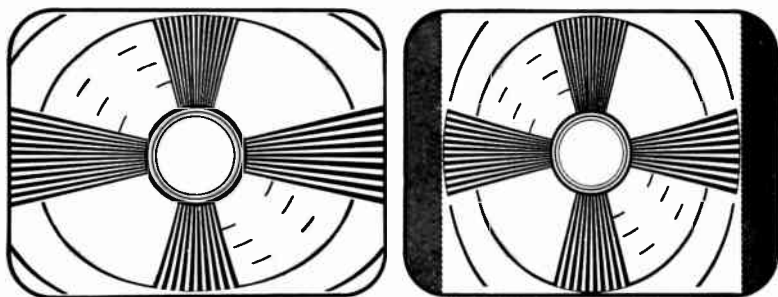

Fig. 14-17.—How the pattern is affected by incorrect adjustment of the width control.

farther into the winding. This adjustment changes the width of the picture uniformly, all parts change their width together. If the picture is originally symmetrical on the left and right it will remain so.

Although the picture remains symmetrical it is uniformly stretched from left to right by too much width, with the result illustrated at the left in Fig. 14-17. With too little width there is uniform compression, with the result at the right in Fig. 14-17. If such patterns are not examined for symmetry, and for having the pattern center midway between the edges, they might be taken as indicating need for adjustment of linearity rather than of width.

Damper Action.—At the top of Fig. 14-18 is represented a sawtooth voltage wave such as applied to the control grid of the output amplifier. During the rising portion this voltage becomes more and more positive. The grid of the tube has been negatively biased by grid rectification with the grid capacitor and grid resistor. The circuit is so designed that when the sawtooth voltage has reached about half its height this voltage is sufficiently positive to overcome the negative grid bias. Then the tube commences to conduct plate current at the instant designated *a* on the graph.

Plate current increases from zero as shown down below. At instant *b* the sawtooth voltage goes suddenly negative. There is instant cutoff of plate current, and a drop to zero current. Current does not resume in the amplifier until the sawtooth voltage again overcomes the negative bias, at instant *c*. Then there is another rise and sudden drop of plate current. Plate current is the amplifier and in the transformer primary thus contains an interrupted series of pulses.

In the transformer secondary winding and in the deflection coils there is an increase of current due to induction of the changing plate current. This rising coil current is shown from 1 to 2 in Fig. 14-19. At the instant of plate current cutoff in the amplifier the very sudden decrease of plate current induces a secondary voltage of reversed polarity, which causes the equally sudden reversal of coil current shown from 2 to 3. This heavy current in the coil circuit builds up a strong magnetic field around the coils and the transformer winding. As this magnetic field collapses its inductive effect causes coil current to continue from 3 to 4.

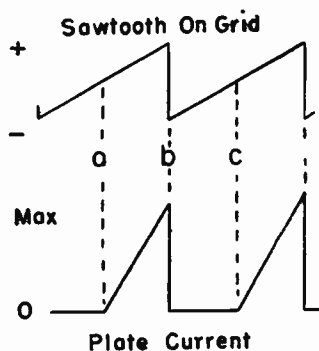

Fig. 14-18.—Pulses of plate current resulting from sawtooth voltage on amplifier grid.

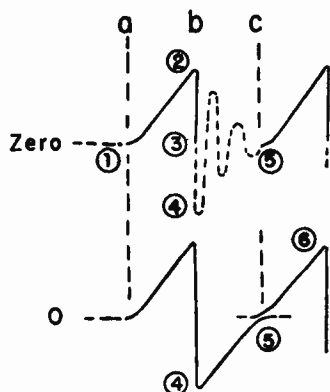

Fig. 14-19.—How the damper suppresses oscillation in the deflection coil circuit.

Now we have a magnetic field which is expanding and then collapsing. In the coil transformer circuit there is considerable distributed capacitance, which can charge and discharge. We have all conditions necessary for continued oscillation in this circuit, and, with alternate transfer of energy between magnetic and electrostatic fields, there could be oscillation as represented by the broken-line curve from 4 to 5. The oscillation frequency would be that corresponding to the inductance and distributed capacitance in the circuit, and it would continue until damped out by losses in circuit resistance or until the start of the next current due to amplifier action, at 5.

The damper acts to prevent continued oscillation. Voltage on the damper plate becomes positive at the end of the retrace current, point 4. As shown by the graphs, the current at point 4 is negative in the kind of cycle being considered. But the inductance of the coil circuit is so large and its capacitance so small that we have a highly inductive circuit. Under this condition the current lags the voltage by nearly 90 degrees, or the voltage leads the current. Consequently, at point 4, voltage on the damper plate commences to go positive.

As soon as the damper plate is positive with reference to its cathode this tube conducts heavily. Instead of oscillation continuing at the resonant frequency of the circuit the very first oscillation is damped out along a fairly smooth current curve

SWEEP AMPLIFIER AND DEFLECTION CIRCUITS 281

from 4 to 5 in the lower graph of Fig. 14-19. This damped half-cycle of coil current dies away at zero just as a new current is commencing, due to action of the amplifier and its plate current. The two currents act together at point 5 and, actually, there is a smooth change of coil current all the way from 4 to 6. This is the change of current which deflects the beam during an active horizontal trace or line. The sudden changes, such as those ending at 4 and commencing at 6, represent the current which causes the horizontal retrace.

An oscilloscope trace taken from the plate of a damper connected as in Fig. 14-9 will appear about as shown at the left in Fig. 14-20, or the negative dips may be squared off, depending on the type of scope used. The a-c voltage of this trace will be



Fig. 14-20.—Oscilloscope traces taken from a diode damper tube.

very great. A trace taken at the cathode of the same damper will have the general appearance shown at the right. Here the voltage is only a small fraction of that in the plate trace. Incidentally, it is the strong negative pulses shown on the plate trace which provide feedback for negative pulses added to the sawtooth voltage wave with systems such as in Fig. 14-15.

Damper tubes usually are twin diodes with plates tied together and with cathodes tied together. Tubes primarily designed for power rectifiers often are used in this position. In some circuits the damper tube is a twin triode (6AS7-G) designed especially for this service. A damper tube must withstand high peak inverse voltages, and ordinarily amplifier types are not satisfactory.

Damper As B+ Voltage Booster.—If you look back at the portion of the circuit including the damper tube and linearity control in Fig. 14-9 it becomes plain that the arrangement is much like that of the rectifier, filter choke, and filter capacitors of the familiar d-c supplies for B-voltage. Voltage waves from the damper cathode charge the capacitor which precedes the linearity

choke. The voltage is smoothed out by this capacitor, the linearity choke, and the capacitor on the other side of the choke. At this output side of the linearity choke appears a d-c potential in the neighborhood of 40 to 70 volts higher than the B+ voltage supplied to the damper circuit from the B-supply system of the receiver. This higher voltage represents energy which has been recovered from the damping action.

The relatively high voltage from the linearity choke output is applied through the transformer secondary to the plate of the output amplifier. Without increase of the primary B-supply voltage there then is more plate current, and greater changes of current in the deflection coils. B-voltage coming from the linearity choke may be applied to only the plate of the horizontal output amplifier, or it may be used also for the amplifier screen voltage, for the plate of the horizontal oscillator or discharge tube, for the vertical sweep oscillator and vertical sweep amplifier, and even so far back as the last sync tube.

Linearity Controls.—If a picture is perfectly linear everything in it will occupy a position in relation to everything else which is exactly the same as in the original televised image, and everything in the reproduced picture will have the same relative shape

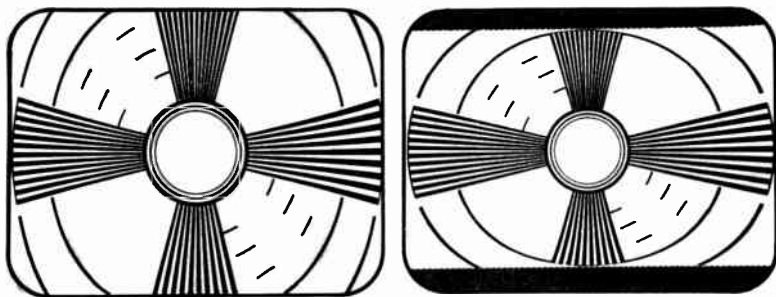

Fig. 14-21.—How the pattern is affected by incorrect adjustment of the vertical size or height control.

and proportions as in the original image. In every receiver there are controls intended for the express purpose of making the reproduction linear. Linearity in a vertical direction is affected also by the height or vertical size control. Too much or too little height will produce effects represented in Fig. 14-21, stretching or compressing the picture from top to bottom. Linearity in a

SWEEP AMPLIFIER AND DEFLECTION CIRCUITS 283

horizontal direction is affected also by controls for horizontal linearity, and by drive or peaking controls and by width or horizontal size controls.

Linearity can be satisfactorily checked only while receiving a test pattern. Then it is possible to tell whether or not the central circle is truly centered, whether outer circles of the pattern are truly circular or are egg shaped, and to tell whether there is stretching at the top or bottom, with crowding below or above, or stretching and crowding at the sides. In spite of all the attention paid to obtaining good linearity it is astonishing what lack of linearity can be tolerated in a picture. People watching a picture have only their memory of similar things to serve as a basis for comparing shapes and relative sizes, they take it for granted that there is no distortion, and a receiver which reproduces a badly misshapen test pattern may not be criticized for picture reproduction.

Linearity Control By Amplifier Bias.—When voltage is applied across a capacitor with resistance in series, as is the case with the sawtooth capacitor, the charge and voltage on the capacitor will increase with time about as shown at the left in Fig. 14-22. The charge and voltage rise to half their final value in less than one-fourth the total time, and to three-fourths their final value in less than half the total time.

Were we to use a voltage which is changing at such a non-linear rate for vertical deflection, or to control current for vertical deflection, too much of the pattern or picture would be crowded into the top half, as at the left in Fig. 14-23. In a horizontal deflection system too much would be crowded into the left-hand side.

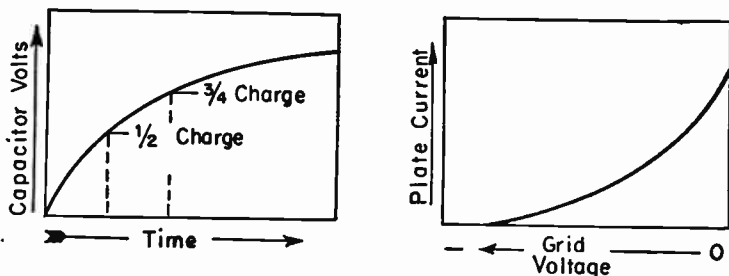

Fig. 14-22.—A non-linear sawtooth charging curve may be compensated for by a non-linear grid-plate characteristic of the amplifier.

It is the beginning of the sawtooth curve that affects the top of the picture in vertical deflection, and the left-hand side in horizontal deflection, because the fields start from the top of the raster space and the horizontal lines start from the left side of the space.

If the non-linear charging voltage on the capacitor is applied to an amplifier so biased as to have a grid-voltage plate-current characteristic like the one at the right in Fig. 14-22 the resulting changes of plate current and plate voltage will be approximately linear and sawtooth. The distortion of the amplifier counterbalances the distortion of the voltage curve at the left.

The type of compensation being discussed may be used also to counteract the effects of inductance in the transformer and coil circuits. When voltage is applied to a circuit containing induc-

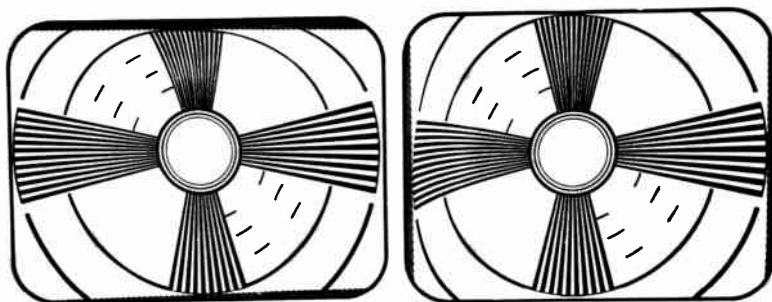

Fig. 14-23.—Effects on a pattern of uncompensated non-linearity in the sawtooth wave of voltage or current.

tance and resistance the current increases rapidly at first, then more and more slowly—exactly as does the capacitor charge and voltage represented at the left in Fig. 14-22. With this kind of plate circuit load the non-linear change of current which would occur normally may be made more nearly linear by compensating curvature in the amplifier characteristic.

The portion of the grid-voltage plate-current characteristic on which the amplifier operates, and also the shape of the curve, may be varied to match or counteract the sawtooth distortion by an adjustable cathode bias. This method of linearity control is in general use for vertical output amplifiers where magnetic deflection is employed for the picture tube. Typical amplifier circuits are illustrated by Fig. 14-24. In both circuits we find the sawtooth

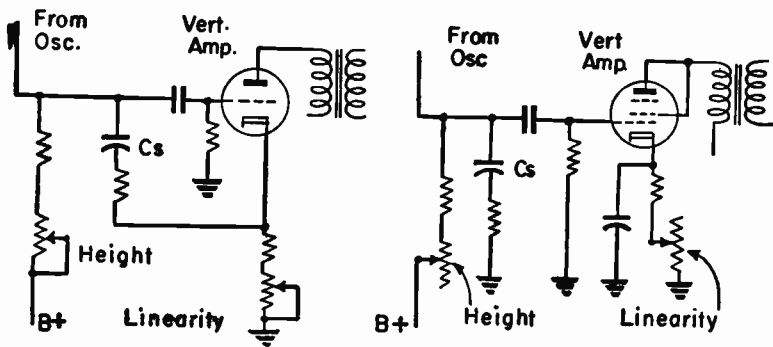

Fig. 14-24.—Vertical linearity controls in amplifiers for magnetic deflection.

capacitor C_s in series with a time delay resistor for producing a negative pulse ahead of the sawtooth.

Adjustment of this type of vertical linearity control has most noticeable effect at the top of the picture or pattern, producing a very decided stretch or compression. When there is adjustment of either this vertical linearity control or of the vertical size or height control the other one of this pair must be adjusted at the same time. Both alter the picture height, and both alter its linearity.

If satisfactory vertical linearity cannot be obtained by adjustment of the linearity and height controls the trouble may be almost anywhere in the vertical sweep system. Check all tubes, including the output amplifier and preceding oscillator or oscillator and discharge tube. $B+$ voltage may be too low. Sawtooth, coupling, or bypass capacitors may be leaky. Any of the resistors may be faulty. There may be trouble in the vertical output transformer, or there may be shorted turns in a vertical deflection coil.

Linearity Control on Damper Circuit.—As shown in earlier circuit diagrams, the adjustable inductor connected between damper cathode and the lower end of the transformer primary is a horizontal linearity control. The effect of adjusting the core in this inductor is to cause a slight shifting in phase of the voltage wave applied to the amplifier plate circuit. This causes some change in the plate characteristic of the amplifier and affects the linearity.

Adjustment of this control corrects for distortion which is most noticeable on the left-hand side of the picture or pattern, a crowding at the extreme left and a shifting of the center elements

toward the left. This will occur with the slug turned too far out of the coil. As the slug is turned toward correct adjustment the elements at the far left will become wider and the center of the pattern will move over toward the center of the screen or mask opening. Adjustment causes some change in width of elements at the center of the pattern, but not a great deal when considered on the basis of percentage change in width in this area. If the setting is very far out there will be some narrowing of overall width of the pattern, but there is little change in total width for considerable change of setting either way from the optimum point.

If the slug is turned too far into the coil the center of the pattern may be moved too far toward the right, with crowding on the right and stretching at the center. In some circuits this adjustment will have the effect of expanding or contracting the center of the pattern, with crowding or stretching on both sides. Adjustment of this control is not as sensitive as that of many other controls. That is, a considerable change is required in the slug position for a given alteration of pattern, and it is quite easy to make a precise setting for a pattern of good proportions.

Linearity Adjustment on Damper.—Again looking back at Fig. 14-9 there will be seen a tapped resistor connected from the plate to the cathode of the damper tube. This is an auxiliary adjustment for horizontal linearity, changed only when satisfactory linearity cannot be obtained by best possible adjustment of the linearity choke, the width control, and a drive control if there is one. Since it seldom is necessary to change the resistance across the damper, this adjustment often consists merely of a lead soldered to one of the taps, although in some receivers there is a tap switch or a continuous adjustment.

Altering this resistance spreads or contracts the left-hand side of the picture or pattern and at the same time makes the overall width greater or less. With less resistance across the damper the left side of the pattern becomes crowded, there is some slight crowding at the center, but there is practically no effect on the right of the pattern. With too little resistance there may appear on the left-hand vertical edge of the pattern a narrow very bright band. Increasing the resistance stretches out the left side of the pattern, increases overall width, and has the effect of moving the center of the pattern toward the center of the screen or mask

SWEEP AMPLIFIER AND DEFLECTION CIRCUITS 287

opening. Whenever this resistance is changed it is necessary to readjust the width control, the linearity choke, and a drive control if the receiver uses this latter adjustment.

Triode Damper Tube.—Fig. 14-25 shows a circuit often used when the damper tube is a twin triode instead of a diode. The two plates, two grids, and two cathodes are tied in pairs. Voltage pulses from the deflection coil circuit are fed to the grids through a coupling capacitor C_c . Between the grids and the cathodes is connected an adjustable resistor used for horizontal linearity control. This adjustment varies the instant in each cycle at which the damper becomes conductive, or the portion of the cycle in which there is conduction.

This linearity adjustment affects chiefly the left-hand side of the picture or pattern, expanding or contracting this side with some increase and decrease in overall width. In some receivers

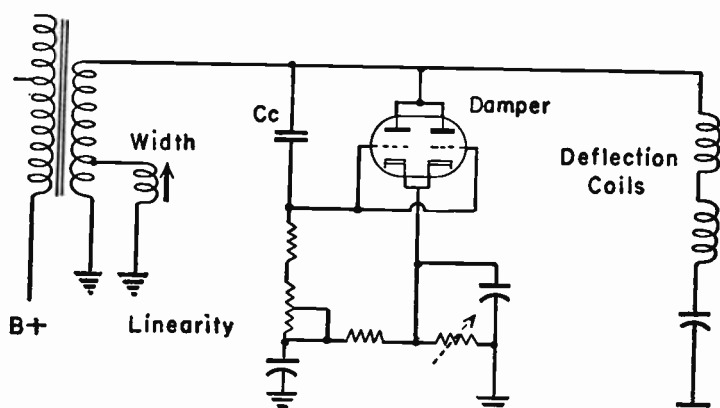

Fig. 14-25.—A twin triode used as the damper tube.

which use a triode damper there is a second adjustable resistor, marked with a broken-line arrow, in the lead from cathode to ground. This also is a horizontal linearity adjustment whose chief effect is on the left-hand side of the pattern. When there are two adjustments the one in the grid lead may be used to obtain linearity of the pattern center, while the one in the cathode lead is used to make the left-hand side symmetrical with the right.

Linearity Troubles.—Faulty horizontal linearity may be due to misadjustment of any one of many controls. These include the

drive or peaking control, the width control, and all the controls designed especially for horizontal linearity. Nearly always it is necessary to adjust all these controls at one operation, because each affects some parts of the pattern more than other parts, yet each has some effect on every area.

If continued and careful adjustment of controls fails to produce satisfactory linearity the trouble may lie anywhere between the horizontal sweep oscillator or discharge tube and the horizontal deflection coils. It is a case for making tube substitutions, for checking all capacitors and resistors, for checking transformer windings and deflection coils for shorts and grounds, for measurement of B-supply voltage, and all connections at the many elements of the horizontal deflection system. During some periods when test patterns are being transmitted it is barely possible that the pattern itself is non-linear. Tests should be made in more than one channel if possible.

Chapter 15

PICTURE TUBE SERVICE AND ADJUSTMENTS

Connections to all internal elements of electrostatic picture tubes are made through base pins which match openings in a socket supported by the tube base and having flexible lead connections. Basing connections for electrostatic tubes in general use are shown by Fig. 15-2, as they appear when looking toward the end of the tube neck or toward the bottom or outside end of the socket.

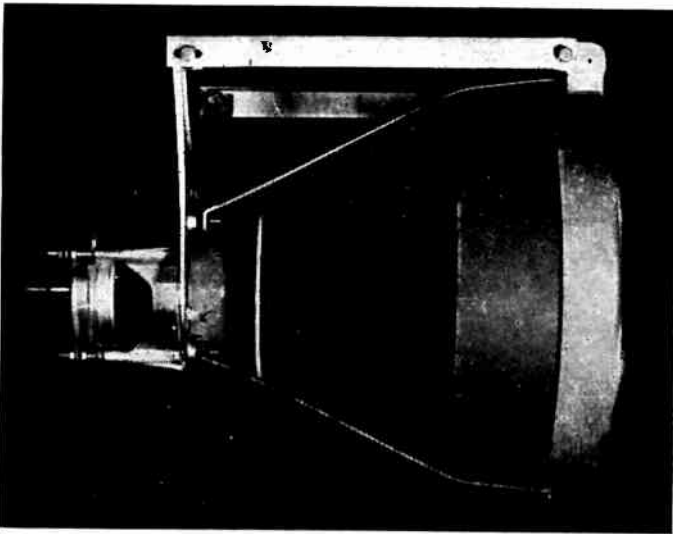

Fig. 15-1.—A Du Mont 15-inch picture tube supported in its mounting.

We already are familiar with functions of the cathode and grid 1, which is the control grid for intensity of the electron beam. Anode 2 is the accelerating anode which draws electrons from the cathode, through the control grid, and speeds them between the deflecting plates to the screen. Anode 1 is the element for electrostatic focusing. It is connected to the slider of the focusing potentiometer in the high-voltage bleeder system.

The pair of deflection plates closer to the screen, or farther from the base of the tube, usually are employed for vertical deflection. To identify the numbered pins the abbreviation *Vert* is placed near them on the diagrams. The pair of plates farther from the screen or closer to the base, is used for horizontal deflection in most cases. Their pins are identified on the diagrams with the abbreviation *Hor.*

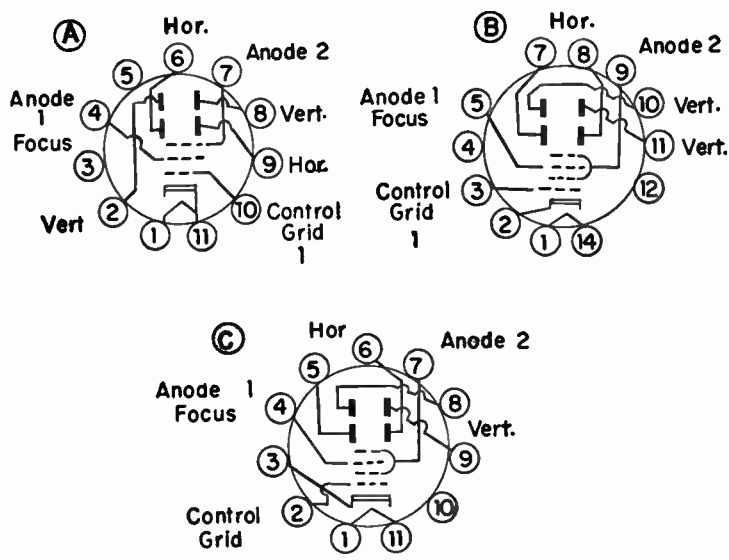

Fig. 15-2.—Basing connections for picture tubes having electrostatic deflection and focusing. A, 7EP4. B, 7GP4 and 7JP4. C, 3KP4.

As mentioned in another chapter, oscilloscope connections for observing deflection waveforms should be made on the tube sides of coupling capacitors which are between the plates and the deflection tubes. Potentials at the plate pins themselves are on the order of four or five thousand volts. These high voltages are present also at the second anode or accelerating anode. At the first or focusing anode the potential usually is 1,000 volts or more. All this refers to 7-inch tubes generally used in receivers having electrostatic deflection systems. Waveforms observed on the tube side of the coupling capacitors will be of sawtooth form, with opposite polarities or inverted polarities for the opposite plates of

PICTURE TUBE SERVICE AND ADJUSTMENTS 291

each pair. Peak to peak a-c voltage of the sawtooth waves usually is around 300 volts.

On the neck of a magnetic deflection picture tube will be the deflecting yoke and the focusing coil in approximately the relative positions shown by Fig. 15-3. In the deflecting yoke are four coils, two arranged above and below the neck for horizontal deflection, and the other two on opposite sides of the neck for vertical deflection. The yoke ordinarily is enclosed in a fibre cover to prevent injury to coil windings during handling and adjustment. The focusing coil consists of a single winding within a protective case.

The deflecting yoke and focusing coil are carried in a supporting bracket or framework. There is provision for rotation of the yoke through a limited distance around its axis and the axis of the tube neck, and clamps for locking the yoke in any position within the adjustment range. There are provisions for tilting the

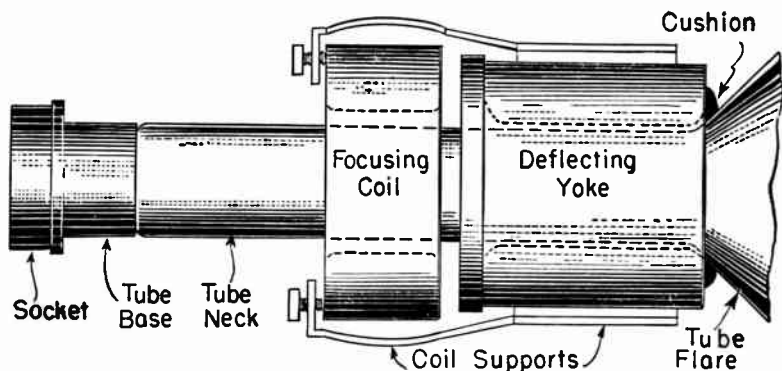

Fig. 15-3.—Focusing coil and deflecting yoke supported around the neck of a magnetic deflection picture tube.

focusing coil a limited amount in any direction with reference to the axis of the tube neck. That is, the axis of the focusing coil itself may be "pointed" in almost any direction toward the front or screen end of the picture tube.

The deflecting yoke has some clearance around the neck of the tube, but the yoke axis and neck axis should coincide—the yoke should be concentric with the neck. There is greater clearance between the inside of the focusing coil and the outside of the tube

neck, to allow tilting of this coil as required in service adjustments. Note that the deflecting yoke is pushed as far as possible toward the tube flare or toward the screen of the tube, where the screen end of the yoke rests against a flexible cushion. Note also that the focusing coil is not pushed right up against the deflecting yoke, there is a space of about $\frac{3}{16}$ to $\frac{3}{8}$ inch between the two units.

On some picture tubes there is a third unit, called the ion trap, located between the focusing coil and the tube base. This trap and its adjustment will be discussed later in this chapter.

Basing connections for magnetic deflection tubes in general are shown by Fig. 15-4 at the left. Connections at the right are for a seldom used tube employing magnetic deflection with the usual yoke, but having electrostatic focusing by means of its anode number 1. Because of the omission of deflecting plates and focusing anodes from magnetic deflection tubes their base connections are few. Pins 6 and 7 of the tubes represented at the left are merely to help locate and hold the socket on the base. Grid 2, which helps to correctly form the electron beam, usually is operated at a potential of about 250 volts.

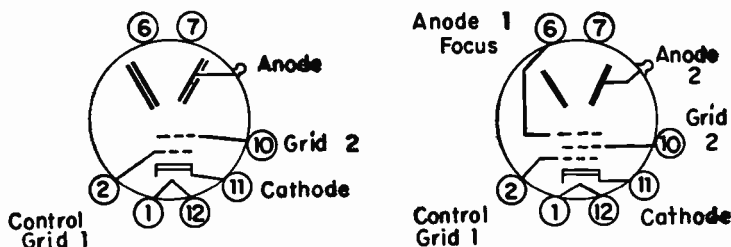

Fig. 15-4.—Basing connections for picture tubes having magnetic deflection.
Left: 10BP4, 10EP4, 10FP4, 12JP4, 12KP4, 12LP4, 15AP4, 16AP4, and 20BP4.
Right: 7DP4.

The terminal for the high-voltage anode is a ball or cup on one side of the tube flare. This anode is a conductive coating inside the flare. On the outside of the flare, extending from a little ways back of the screen to the beginning of the neck, is a second conductive coating which is grounded. Potential at the high-voltage anode of 10-inch and 12-inch tubes is not less than 8,000 volts and not more than 10,000 volts. In direct viewing tubes of larger diameter the anode potential averages somewhat higher, but usually will not exceed 15,000 volts even for a 20-inch tube.

Effects of Anode Voltage.—The high-voltage anode in both magnetic and electrostatic picture tubes acts to give electrons in the beam very great acceleration and speed toward the screen. This voltage tends to keep the beam on a straight line between the electron gun in the neck and the approximate center of the screen. In order to deflect the beam for scanning, this straight-line effect of anode voltage must be overcome by the voltages applied between electrostatic deflection plates or by the current in magnetic deflection coils, or, more correctly, by the electrostatic or magnetic fields through which the beam passes.

If anode potential remains unchanged, an increase of deflection voltage or current will make the beam travel farther vertically or horizontally, and will make the picture higher or wider. But, with any given deflecting voltage or current, an increase of anode voltage will hold the beam more nearly to a straight line, or will allow less deflection and will make the picture of less height and less width at the same time. If anode voltage becomes too low, the original deflection voltage or current will have, relatively, more effect and the picture will become higher and wider. At the same time the electrons in the beam are not held so well together, and the picture becomes fuzzy beyond the point at which any focusing adjustment will make a correction. Also, the widening or heightening effect may be more than can be overcome by adjustment of the size controls.

The brightness of the picture depends not only on the density of electrons in the beam, as regulated by the control grid, but depends also on the speed of the electrons when they collide with the screen. Any increase of anode voltage raises the electron speed and makes the picture brighter, while a drop of anode voltage makes the picture less bright. Of course, some of this is due to more electrons being pulled from the cathode by higher anode voltage, and fewer by low anode voltage, but the electron speed has a lot to do with it.

Keeping in mind the related effects of anode voltage and deflecting voltage or current will help explain much of the behavior of patterns and pictures observed during various adjustments.

Picture Tube Masks.—The dimensions of the photosensitive surface in television camera tubes, on which the televised image is focused, always are such that the ratio of width to height is

4 to 3. In some camera tubes the dimensions are 3.00 inches wide and 2.25 inches high. In others the width may be about 1.28 inch and the height about 0.96 inch. The ratio always is 4/3. The transmitted picture will have this same aspect ratio if proportions are not changed.

With an aspect ratio of 4/3 the complete picture may be fitted within an oblong mask in front of the picture tube screen as shown at A in Fig. 15-5. The slight rounding off of the corners is of little importance. On a 12-inch tube this will allow width and

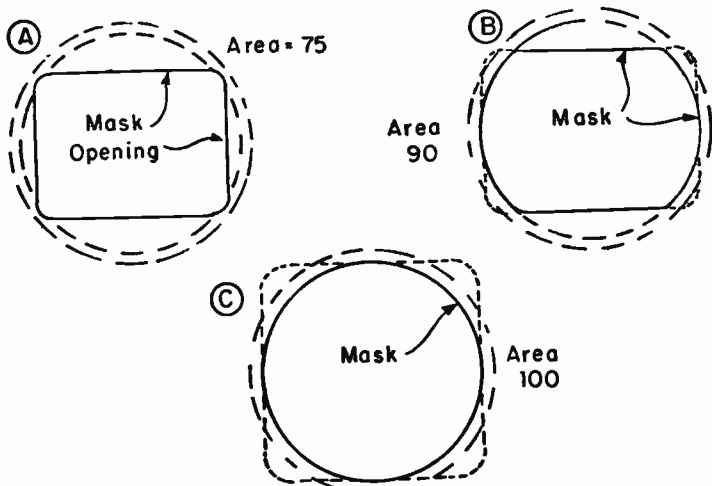

Fig. 15-5.—Picture areas and mask openings for a picture tube of the same screen diameter in all cases.

height little if any greater than 10.0 by 7.5 inches, for an area of 75 square inches if we neglect the slight corner cutting.

There is room on the screen for a picture which is higher and wider. If the width is increased so that the sides of the picture come all the way out to the limit of the useful circle of the screen we have the result shown at B. The corners will be further cut off, as shown by the broken lines, but not much of importance happens in the four corners of a televised scene. Now the picture is higher and wider, and the area has been increased to 90 square inches with the same size picture tube.

If the picture were enlarged uniformly until it extended to the top and bottom of the useful circle of the screen there would be

a good deal cut off from both sides, and important details might not appear in the reproduction. To increase the area without cutting off the sides, the width may remain as at *B* but the height may be increased to fill the whole circle of the screen. The result is shown at *C*. There is somewhat greater cutting of corners than at *B*, but the area has been increased to 100 square inches, still with the same picture tube.

When using a standard test pattern while adjusting the height control for a picture of the proportions at *C* the circles and squares or rectangles of the pattern will be stretched out in the vertical direction. Squares will become oblongs and circles will become ovals with their longer dimensions vertical.

Handling the Picture Tube.—Picture tubes are quite costly, and should be protected against damage because of the expense in replacement. This is a good reason, but by no means the most important reason for care in handling picture tubes. These tubes are highly evacuated, and they have large surface areas. The difference between external atmospheric pressure and internal evacuated pressure is astonishingly great, it is a matter of tons, not pounds. In case of breakage the inrush of air and its rebound with accompanying particles of tube make the consequences disastrous to persons who are near and not suitably protected. The first rule for safety is never to handle a picture tube which is out of the chassis or cabinet, and never attempt to remove and replace this tube, without wearing shatterproof goggles, heavy gloves, and enough clothing to protect arms and body. A rule just as important is to allow no one close to the operation unless they are similarly protected.

While a tube is removed do not hold it against your body while handling. Take every precaution not to scratch and thereby maybe start a crack in the glass. Don't use metal tools near the picture tube. Never allow the tube to strike or bump against anything hard, and take especial care not to strike the neck or the portion where the front screen area joins the flare. While the tube is out of the chassis or cabinet it is most safely stood with the screen face down, resting on some soft surface such as thick felt, and with enough support that there is no chance of tipping over and striking on the neck. The tube should not be allowed to remain where there may be large and sudden changes of tempera-

ture. When replacing a tube use only the most moderate pressure, never force it into position, and never force the deflection yoke, focusing coil, or ion trap onto the neck. Everything must be sufficiently free for easy sliding.

Removal and Replacement of Picture Tube.—Picture tubes may be mounted in the cabinet, as in Fig. 15-6, or on the chassis.

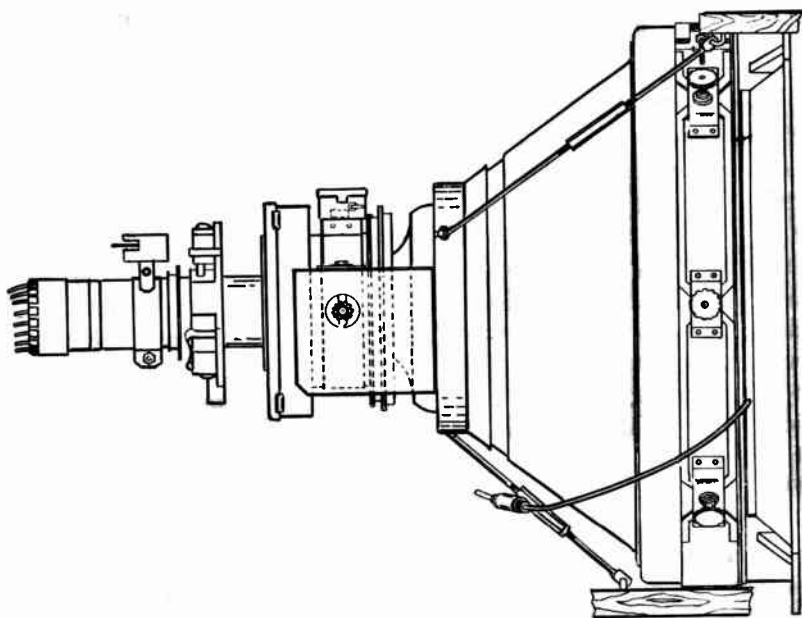

Fig. 15-6.—This picture tube for color television is supported from the cabinet by means of long rods in which are turnbuckles.

The exact steps in removal and replacement of the picture tube depend, of course, on mechanical details of the mounting in different receivers. The first step is to make a careful examination of all brackets, clamps, cushion supports, and electrical connections, with a view to determining the safest way of carrying out the work. In a general way the operation will be carried out as follows:

Remove the socket cover and take off the socket with its leads. If the tube is a magnetic deflection type grasp the insulator of

the high-voltage lead and remove it from the anode terminal on the flare. Since there is possibility that the capacitance between inner and outer coating may retain a charge, use a piece of insulated wire, with the ends bared, to make connection from the terminal cap or ball to the outer coating. Then make sure that the high-voltage filter capacitor is discharged by touching the contact end of the cable to chassis metal.

If the tube is of the magnetic deflection type disconnect the leads for the deflection yoke, for the focus coil, and for the ion trap if it is of the electromagnetic kind. There may be plug connectors or soldered leads. If leads are soldered it is necessary to make careful note of the color coding or of other identifications for correct replacement. Note also the position of the tube with reference to its supports. That is, check the position of the anode cap, the key on the base, or some other feature with reference to fixed parts of the chassis, mounting, or cabinet.

Now examine the supports for the tube, and for the coils of a magnetic deflection system. Cushions will carry the large end of the tube, either on the chassis or in the cabinet, and there will be a cushion around the neck where it joins the flare.

If the picture tube is mounted on the chassis the usual procedure is to slide the ion trap off the neck, if there is such a trap, then to loosen or remove supports at the large end of the tube, and slide it out through the deflection yoke and focusing coil. Support the tube with great care that no strain is placed on the neck as it comes through the coils. With some constructions the tube may remain supported at its large end and by the bracket and cushion at the neck while the coil assembly is slid off the neck. Then the tube may be removed with these other parts out of the way.

Sometimes the picture tube has to be removed through the front opening of the cabinet after the frame parts around the mask and those carrying the mask are taken off. This will allow sliding the tube out of the deflection yoke and focusing coil. To avoid possibility of strain, it is best to loosen all clamps used for adjustment of the coils so that the coils remain quite free to move. When the picture tube is carried by a bracket attached to the cabinet the clamps or other fastenings of the bracket are removed. Then the bracket with the tube still supported in it may be removed from the cabinet.

Replacement of the tube is largely a matter of reversing the steps for removal. There are, however, a few additional precautions. Make certain that coil adjustments are loose enough that there can be no binding on the tube neck. Hold the tube carefully with your hands until it is supported by the cushion mountings. Make sure that the back of the flare comes against the cushion. The tube must be supported entirely by cushions at the large end and at the back of the flare, never by the neck in any manner. See that the grounding spring attached to chassis or bracket metal rests firmly on the outer coating of a magnetic deflection tube having such coating. Finally, don't force the large face of the picture tube against the protective window of the cabinet.

Deflection Coils.—Fig. 15-7 shows the general form of oscilloscope traces obtained with the scope connected from one end of a pair of coils to ground. A trace taken from the vertical coils shows the sawtooth waveform quite clearly, with long, thin negative pulses for the vertical retrace of the picture tube beam. The

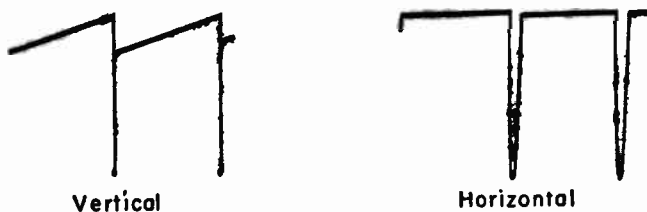

Fig. 15-7.—Oscilloscope traces taken from terminals of deflection coils.

sawtooth rise need not be straight, as shown, but may have some curvature without indicating poor linearity. The sawtooth portion of the wave will undergo much change of form if the vertical linearity control is varied while the scope is connected, and will change in height with variation of the horizontal size or height control and of the drive control.

These traces are not very useful for making linearity adjustments because the waveform is that of voltage across the coils, and in a circuit containing much inductance in comparison with resistance the voltage waveform is not the same as the current waveform. It is the current waveform that counts in magnetic deflection.

Oscilloscope traces taken from the high end of the horizontal

deflection coils appear as at the right in Fig. 15-7. They are the same as traces taken at the plate of the damper tube. Again these voltage waveforms bear little resemblance to the current waveforms in the coils, and do not show actual deflection. The depth of the negative pulses will change with variations of the drive control.

The traces will not be the same when taken from the low end of a coil which connects directly or through a capacitor to a lead in the B-supply. They will show only a-c loops or waves whose voltage is small in comparison with that at the high end. If a coil is grounded at the low end, as in some vertical systems, there will, of course, be only a straight horizontal line as the trace.

Tilting of Pattern or Picture.—In Fig. 15-8 the test pattern is shown as tilted or skewed with reference to the edges of the mask. With an electrostatic deflection tube this is corrected by rotating the tube in its supports. Note the direction in which the pattern

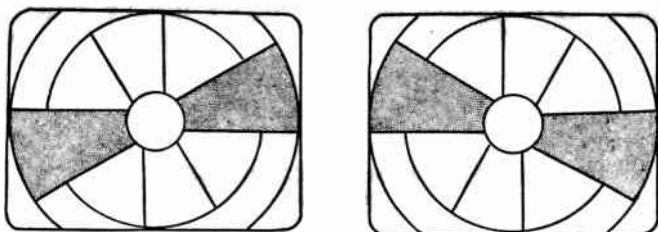

Fig. 15-8.—Tilting which is corrected by rotating an electrostatic tube or by rotating the deflection yoke of a magnetic tube.

should be rotated for correction. Then turn off the power, loosen the tube supports, and rotate the tube in the same direction. Turn on the power and note the results. Shift the tube only while power is turned off. Tighten the supports when the job is completed.

With a magnetic deflection tube the tilting is corrected by rotating the deflection yoke around the neck of the tube without moving the tube itself. On the mountings for all deflection yokes there are provisions for loosening the yoke and allowing its rotation through a few degrees. Note the required correction, turn off the power, and rotate the deflection yoke in the same direction the pattern should be turned.

Focusing.—Electrons in the picture tube beam have a natural

tendency to spread apart as they travel from the electron gun to the screen. This comes about because electrons are negative charges or have negative charges, and negative charges repel one another. For a picture with distinct details the electrons in the beam must be made to converge to a very small spot where they strike the screen. Then the horizontal trace lines will be sharp, and clearly distinguishable from one another. This is accomplished by focusing the beam.

Focusing in electrostatic deflection and electrostatic focus tubes requires adjustment of the ratio of the voltage on the focusing anode, number 1 of Fig. 15-2, to the voltage on the accelerating anode, number 2. In practice the voltage on anode 2 remains unchanged and the voltage on anode 1 is altered for focusing. Voltage for the focusing anode is taken through the slider of a potentiometer in the resistance bleeder line running from the high-voltage rectifier to ground.

Focusing in tubes having magnetic deflection and magnetic focusing is accomplished by varying the current which flows in the focusing coil on the neck of the picture tube. A few of the many arrangements used for adjusting current in the focusing coil are shown by Fig. 15-9. At the left the coil forms part of the filter system in the low-voltage B-supply for some tubes in the receiver. Movement of the control slider varies focusing coil current by more than one-third while varying the B+ voltage about four per cent. In the center diagram the focusing coil is shunted across resistors at the low voltage end of a bleeder in the B-supply system, with one of the resistors a potentiometer for

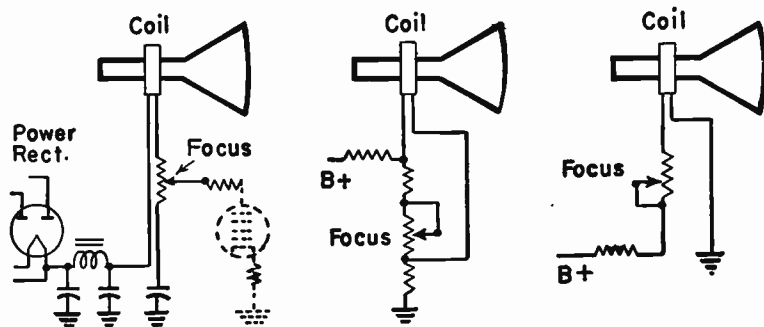

Fig. 15-9.—Circuits for control of magnetic focusing

focusing control. At the right the focusing adjustment is a variable resistor in series on a B+ bleeder line, with one end of the coil grounded.

The higher the voltage on the high-voltage anode of the picture tube the more current is required in the focusing coil for sharp focus of lines. The position of the focusing coil with reference to the deflection yoke on one side and the electron gun of the tube on the other side is somewhat critical. If the focusing coil is too far back toward the electron gun it may be impossible to obtain a spot small enough for distinct horizontal lines. If too near the deflecting yoke the magnetic fields of the coil and yoke may act together to tilt or skew the pattern in the mask.

The focusing control may be given its preliminary setting while observing only a raster on the picture tube screen, with no pattern or picture. Adjust the control so the fine horizontal trace lines are clearly visible. The curvature of the tube face is not the same as an arc centered in the focusing coil. That is, the outside of the screen circle is farther from the center of the coil than is the center of the screen. Consequently, it is impossible to obtain equally sharp focusing over the entire screen area. Most satisfactory pictures are produced by getting the best possible average focus near the center and well out toward the sides of the screen, while tolerating poorer focus at the extreme sides, top, and bottom.

Once the focusing control is satisfactorily adjusted there should be no need for change over long periods. Keep in mind that inability to get good focusing may be due to low voltage at the picture tube anode. When an ion trap is used on the picture tube it is necessary to adjust this trap and the focusing together, as will be explained in pages following.

Centering Controls.—Even with the center of the picture tube screen centered in the mask, the reproduced pattern or picture may not be centered. It may be too low or too high, too far to the left or the right, or out of position in more than one direction as shown by Fig. 15-10. This calls for adjustment of centering controls.

The principle employed for centering with electrostatic deflection tubes is illustrated by Fig. 15-11. The control units are center-tapped potentiometers connected in parallel with each other and

in series with the high end of the high-voltage power supply. One of the horizontal deflection plates is connected to the center tap on the horizontal centering control, and the other horizontal plate is connected to the slider of the same potentiometer. The vertical deflection plates are similarly connected to the other potentiometer, which is the vertical centering control.

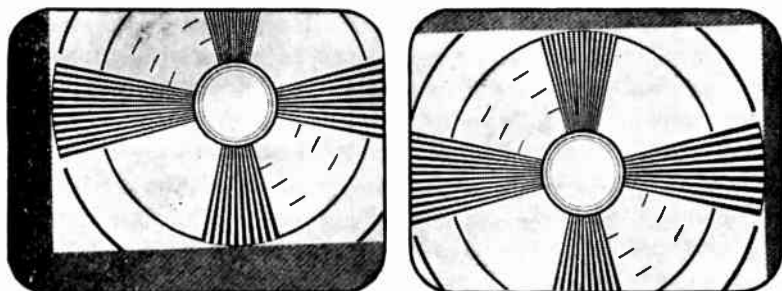

Fig. 15-10.—Effects of misadjustment of centering controls or incorrect tilting of a focusing coil.

The deflection plate connected to the center tap remains at a constant average d-c potential. Voltage on the other plate of the same pair may be made more positive or less positive by adjusting the slider. This is equivalent to making the second plate either

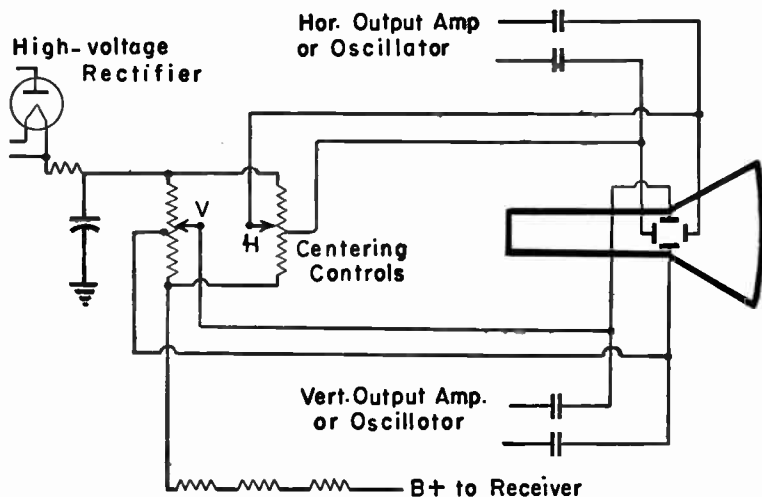

Fig. 15-11.—Circuits in general use for electrostatic centering.

PICTURE TUBE SERVICE AND ADJUSTMENTS 303

positive or negative with reference to the first one. When the second plate is made more positive the electron beam is drawn toward it, and if made less positive or negative the beam is moved toward the opposite plate of the pair. This governs the position of the beam with no deflecting voltage applied from the output amplifier or sweep oscillator. With this voltage applied the beam deflects equally each direction, and the center of the picture remains at the point fixed by the centering voltage.

Centering with picture tubes having magnetic deflection and focusing may be done electrically or by shifting the axis of the focusing coil, or by combination of both methods. For electrical centering a direct current, in addition to the alternating deflection current, is allowed to flow one direction or the other in the deflection coils.

Principles of electrical centering are illustrated by Fig. 15-12. In the diagram at the left one end of the deflection coil circuit is connected to the slider of a center-tapped potentiometer, with the center tap connected through the transformer secondary to the other end of the coils. The ends of the potentiometer may be connected at various points in the B-supply lines, often between the low-voltage B-supply and plate, screen, and biasing circuits for various tubes. Sometimes the potentiometer is connected between B— and ground. In any case, moving the slider one way or the other makes it more or less positive or negative than the center tap and causes direct current to flow one direction or the other in the deflection coil circuit. The resulting d-c magnetic

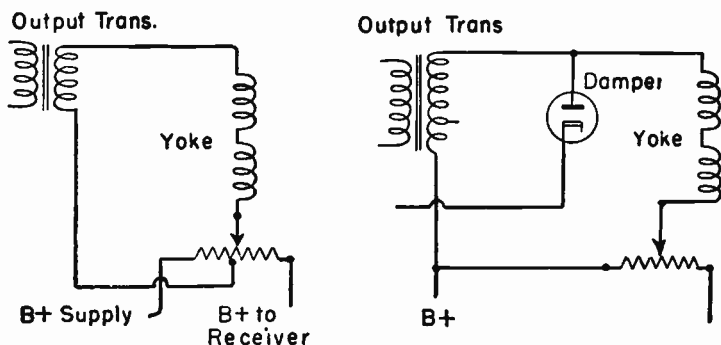

Fig. 15-12.—Circuits in general use for electrical centering with tubes having magnetic deflection.

field centers the electron beam in a direction corresponding to polarity of the direct current.

When a damper tube is used in a horizontal deflection system the centering control may be connected as at the right in Fig. 15-12. Damper current and current from the portion of the control shunted by the coil circuit act oppositely, or rather the corresponding potential differences would act oppositely and tend to cancel. By moving the slider and varying the shunt voltage the direct current in the coils may be changed to effect horizontal centering.

Centering with Focus Coil.—Many receivers have no electrical centering adjustments for tubes employing magnetic deflection and focusing. Rather they provide means for tilting the axis of the focusing coil with reference to the axis of the tube neck for making the small changes of centering required during service work. The adjustment often consists of three screws or three nuts spaced equally around the circumference of the focusing coil and acting to move the coil housing or bracket to any angular position and hold it there. In other designs there are slotted brackets, or there may be a sort of trunnion support allowing the coil to be swung on centers. The mechanics of adjustment always are apparent from examination.

The focusing coil acts as though the electron beam were being aimed along the coil axis in raising or lowering the picture on the screen or in moving it from side to side. The picture may not exactly follow the line through the coil axis, there may be some diagonal shifting of the picture when the coil is rocked vertically or horizontally. In addition to allowing centering of the picture by movement of the focusing coil, some receivers have also electrical centering adjustments which provide a limited range of setting after the raster has been approximately centered with the focusing coil. To obtain satisfactory centering with the focusing coil it is essential that the center of this coil lie on the central axis of the tube neck. That is, when the focusing coil is pointing straight ahead the gap between the inside of the coil and the outside of the tube neck must be the same all the way around.

Ion Traps.—In the stream of electric particles leaving the picture tube cathode are not only electrons but also ions, which are about 2,000 times as heavy as electrons. Were ions to con-

tinually strike the delicate inner surface of the screen at the same place the final result would be a brown spot, called an ion burn. This would happen only in tubes employing magnetic deflection, because the heavy ions are deflected hardly at all by magnetic fields and would go always to the center of the screen. However, the ions are deflected by electrostatic fields, and in tubes employing electrostatic deflection the ions are spread over the entire screen area rather than being concentrated. In some magnetic tubes the screen is protected by a film of metal which stops the ions while allowing electrons to pass through. Other magnetic tubes require ion traps.

An ion trap is a device which deflects the ions against some part of the electron gun or anodes while allowing the electron beam to proceed through the focusing and deflection coils as usual. A widely used type of trap is shown by Fig. 15-13. Both the ions and the electrons are deflected by an electrostatic field in the gap of the ion trap. Around the outside of the tube neck are a pair of ion trap magnets whose fields pull the electrons back to the axis of the tube but have little effect on the ions, which strike the anode and are trapped.

The trap of Fig. 15-13 requires two magnets, one to prevent electrons from striking the anode and another to turn the electrons back to the tube axis. These may be permanent magnets or electromagnets. Fig. 15-14 shows principles of other ion traps which require only a single magnet. At the left is a bent gun trap, in which the original stream of ions and electrons is directed toward the anode by the shape of the gun. Then the

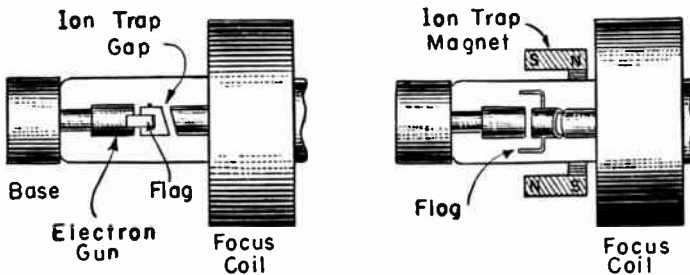

Fig. 15-13.—The ion gap in an electron gun and an ion trap of the permanent magnet type.

single magnet brings the electrons alone back to the tube axis. In the design at the right an electrostatic field between two plates tends to deflect both ions and electrons away from the tube screen. The field of the single trap magnet affects the electrons only, counteracting the effect of the electric field and keeping the electron beam in the tube axis while allowing the ions to strike the anode.

Trap magnets are made in numerous designs. Usually there is an arrow which, with the magnet correctly mounted, points toward the picture tube screen or away from the socket. If a trap is incorrectly mounted, or reversed either end for end or top and bottom, it will be impossible to obtain any trace on the screen no matter how the brightness control is adjusted. Setting of any trap magnet is carried out as follows:

1. Tune in a station, preferably one furnishing a test pattern. Set the brightness control for moderate illumination.

2. If the magnet is clamped on the tube neck with screws or nuts loosen them enough to let the magnet slide lengthwise and be rotated, while remaining in in whatever position placed. Then move the magnet slowly forward and back, while rotating it slowly one way and the other, to obtain maximum screen brightness with no shadowing or cutting off of corners.

3. Reduce the brightness. Adjust the focusing coil or focusing control for most distinct horizontal trace lines.

4. Move the magnet to again obtain maximum brightness.

5. Check the focusing with brightness above normal. If necessary, in order to obtain good focus at the center and well toward the edges, readjust the trap magnet.

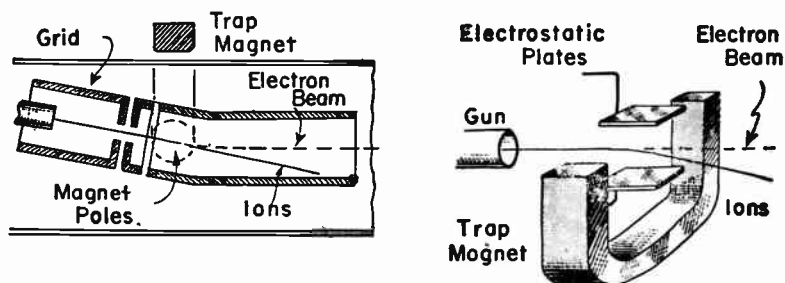

Fig. 15-14.—Ion traps which require only a single magnet.

Chapter 16

TELEVISION POWER SUPPLIES

Some recent types of receivers having electrostatic deflection tubes, and many older types having both electrostatic and magnetic tubes, include B-power supplies following the same principles used in such supplies for radio receivers. Voltages, of course, are much higher, and rectifier tubes are half-wave types designed for such service.

Quite often the high-voltage rectifier and low-voltage rectifier are operated in series to obtain maximum possible B-voltage for the picture tube circuits. Fig. 16-1 shows connections for

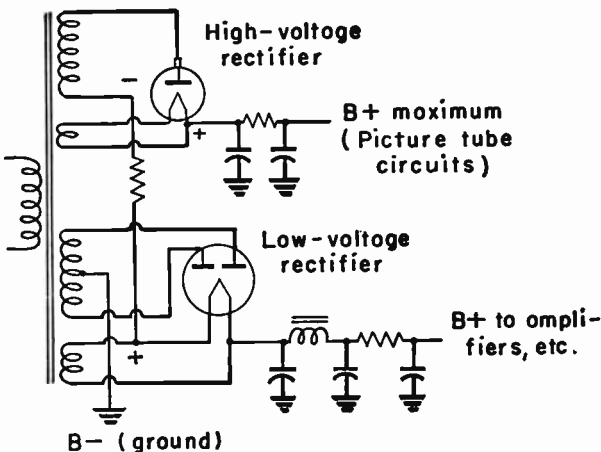

Fig. 16-1.—High-voltage rectifier in series with positive of low-voltage rectifier for B-supply.

one method of series operation. To the positive filament of the low-voltage rectifier is connected the negative end of the plate winding for the high-voltage rectifier. Voltage outputs of the two rectifier systems add together. The most positive point is the filament of the high-voltage rectifier, which feeds the picture tube circuits in the manner shown by diagrams in preceding chapters. The most negative point is at the grounded center tap of the plate winding for the full-wave low-voltage rectifier.

The positive end of this rectifier system feeds plates, screen, and biasing connections of amplifiers and other tubes in video, audio, and sync sections of the receiver.

Fig. 16-2 shows another series rectifier B-supply wherein the highest voltage is negative with reference to ground and the B-voltage for amplifier plates and similar circuits is positive with reference to ground. The picture tube symbol is included to show, in a general way, how this arrangement works out. At the output of the resistance-capacitance filter from the plate of the high-voltage rectifier the potential is several thousand volts negative. The first connection from the filter is to the picture tube grid. The next connection is through the brightness control to the picture tube cathode. Thus the grid is made more

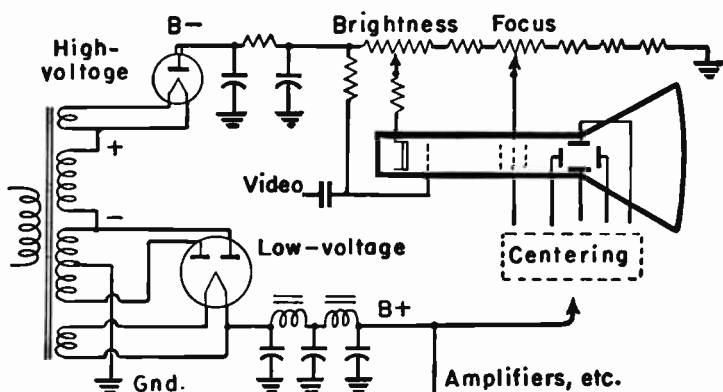

Fig. 16-2.—High-voltage rectifier in series with negative side of low-voltage rectifier.

negative than the cathode. The next connection is to the focusing anode of the picture tube, which makes this anode much less negative and effectively highly positive with reference to the cathode of the picture tube. The voltage divider ends at a ground connection.

Deflection plates of the picture tube are connected through any suitable type of centering control to the positive side (B+) of the low-voltage rectifier. The deflection plates thus are made positive with reference to ground, and very highly positive with reference to the picture tube cathode which is connected to the negative side of the high-voltage rectifier. The sum of

the two rectifier voltages is applied between deflection plates and picture tube cathode.

In any of these 60-cycle B-power supplies the high-voltage rectifier and filter carry only picture tube current, which is a matter of a few hundred microamperes. High-voltage windings on the transformer are of small wire. In series with this winding may be a resistor, as shown in Fig. 16-1, which protects the winding against burnout in case of an overload which would cause excessive current. The resulting increase of voltage drop across the protective resistor holds the current below a value which would damage the transformer winding.

Flyback High-voltage System.—The lower the frequency of a rectified voltage the larger must be the filter capacitors in order to provide adequate smoothing of pulsations in the output. Filter capacitors for 60-cycle high-voltage systems have sufficient capacitance to hold a charge which, considering the very high voltage to the ground, may give a dangerous shock. To reduce this danger, nearly all receivers of recent design have high-voltage power supplies operating at either the horizontal line frequency of 15,750 cycles per second or at some frequency of 100 kilocycles or more which is generated by power supply oscillator for this express purpose. In these systems the filter capacitors are relatively small. The small currents for the picture tube allow using high series resistances in the filters. The combination of high resistance and small capacitance drops the output voltage so low in case of overload or excess current demand as to leave slight danger to those taking usual precautions in handling the equipment.

Fig. 16-3 shows connections for a typical high-voltage system of the so-called "flyback" type, operating at the horizontal line frequency. This general type of voltage supply is used for the high-voltage anode of the picture tube in most of the recent receivers which have a magnetic deflection tube.

During the horizontal retrace period there is sudden collapse of the magnetic fields which have been built up around the deflection coils and the output transformer, this occurring when plate current of the output amplifier drops from maximum to zero. The result is induction of an emf or voltage pulse in the transformer primary which reaches a peak potential of about

5,000 volts. This is the pulse which appears at the plate of the output amplifier and makes it inadvisable to measure voltage at this point.

The extension of the primary winding above the plate connection makes this complete winding act as an auto-transformer for the pulse voltage, and the overall potential is increased to

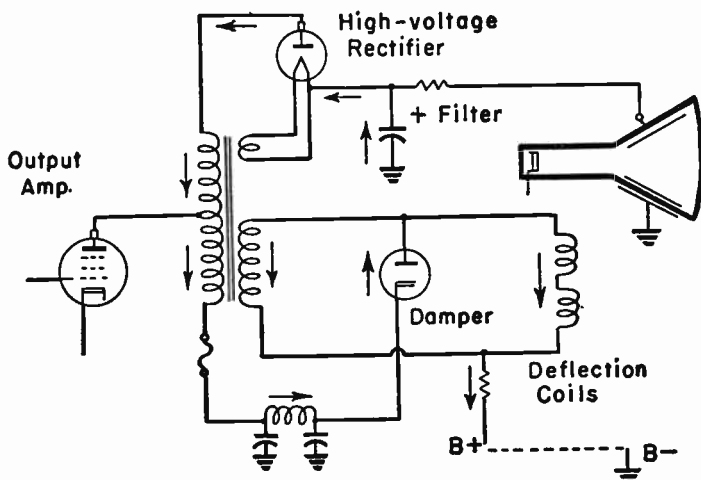

Fig. 16-3.—Typical circuit for flyback type of high-voltage power supply.

about 10,000 volts at the connection to the plate of the high-voltage rectifier. Arrows on the diagram of Fig. 16-3 show the instantaneous directions of electron flow caused by pulse voltage. The electron flow through the high-voltage rectifier and the filter capacitor charges this capacitor, in the marked polarity, to a voltage nearly equal to the peak pulse voltage or to nearly 10,000 volts. This capacitor voltage is applied through the filter resistor to the high-voltage anode of the picture tube.

The small current drawn by the picture tube anode allows using a sufficiently long time constant of filter capacitor and resistor to retain a high charge and high voltage between rectified pulses. Thus the anode voltage remains nearly constant. The total filter capacitance includes that of the capacitor, also the capacitance between inner and outer coatings of the picture tube, and

the capacitance of the cable which makes connection to the anode terminal. At the horizontal frequency of 15,750 cycles per second the capacitance need not be very great to provide satisfactory smoothing of current.

Current for the filament of the high-voltage rectifier is obtained from one or two turns on the output transformer. The filament operates at the horizontal line frequency.

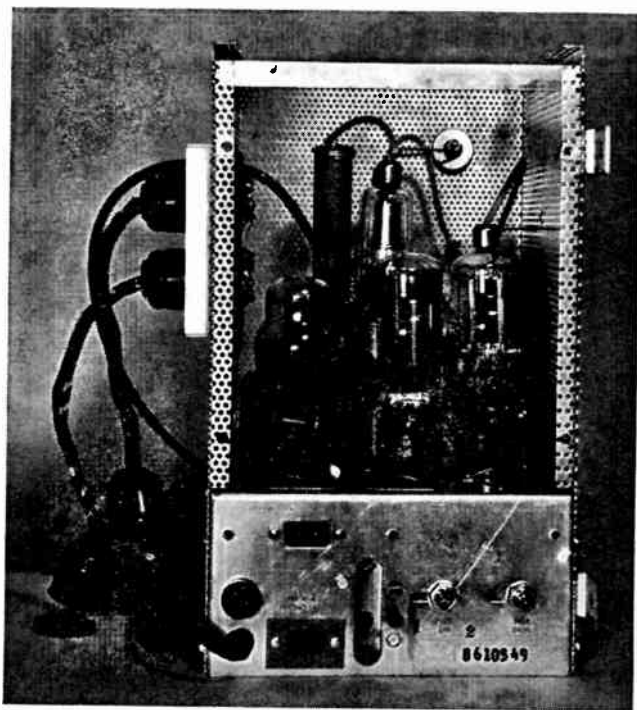

Fig. 16-4.—Rear view of a flyback type high-voltage power supply as used in a Du Mont receiver.

The tubes and other units which operate at high voltages are enclosed within a perforated shield, usually arranged so that it cannot be removed for access to these parts without opening some type of interlock for cutting off the power to the receiver. Fig. 16-4 shows the interior of a flyback power supply chassis. The output amplifier tube is at the extreme right. Behind other tubes and at the center is a high-voltage rectifier tube.

Fig. 16-5 is a picture of the bottom of the same power supply chassis. The output transformer may be seen at the lower left. The right-hand side of this picture is the rear of the chassis base shown by Fig. 16-4. In the base portion are adjustments for horizontal size (an inductor on the transformer secondary), for horizontal linearity (an inductor between damper and transformer primary), and for horizontal drive. The inductor for horizontal linearity is visible in the center at the right-hand end of Fig. 16-5.

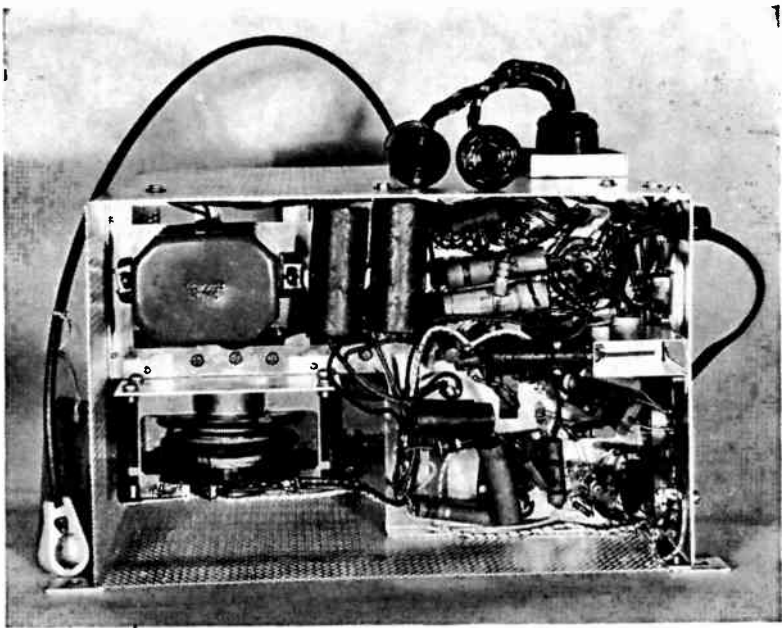

Fig. 16-5.—Bottom view of the Du Mont high-voltage power supply chassis.

It will be recalled that a drive control or peaking control alters the amplitude or height of the sawtooth wave and of the negative pulse preceding the sawtooth. These characteristics of the wave affect the strength of the flyback pulse, whose peak potential determines the voltage on the anode of the picture tube. Consequently, adjustment of the drive or peaking control changes the anode voltage and affects brightness and definition in the picture.

There is some radiation from parts of the high-voltage supply

operating at the horizontal line frequency. This radiation is prevented from causing trouble by using the grounded shield around all such parts. The chance of interference with the picture is further reduced by the fact that the pulses producing the anode voltage occur during retrace periods, when the beam is blanked.

With a high-voltage supply of the flyback type any trouble which stops production of the sawtooth wave stops generation of the flyback pulses and cuts off the anode voltage for the picture tube. This means that failure of the horizontal oscillator, discharge tube, or output amplifier would cut off the beam. Were the beam not cut off, troubles which stopped the sawtooth wave and deflection would leave the beam tracing only a vertical line rather than a raster. Should there be failure of vertical deflection at the same time, the beam would be left stationary at the center of the screen, and would quickly burn the phosphor at this point were there no cutoff action.

In receivers wherein plate current for the horizontal output amplifier is taken through the damper tube, failure of the damper will put the amplifier out of action and cut off the picture tube beam. This is evident from tracing through the electron flow or current paths shown by Fig. 16-3. In that diagram there is shown a fuse in the lead to the bottom of the transformer primary. This is a high-voltage type of fuse, usually of $\frac{1}{4}$ ampere rating. Its purpose is to blow and prevent burning out the transformer winding should the output amplifier become gassy and draw excessive plate current.

Voltage Doublers.—In low-voltage B-supply systems used in radio, television and other electronic applications it is fairly common practice to use voltage doubling circuits. These circuits are supplied from the a-c power line which furnishes positive and negative alternations. Positive alternations cause current through one half-wave rectifier and charge one of two capacitors. Negative alternations cause current through a second half-wave rectifier and charge the other capacitor. Capacitor charge voltages add to line voltages in the output to raise the overall d-c potential difference to nearly double that of the effective a-c voltage of the line.

The pulses available for the high-voltage rectifier in the flyback

314 APPLIED PRACTICAL RADIO-TELEVISION

power supply system are not alternating, all are of positive potential. Therefore, the ordinary voltage doubling circuit cannot be used. Instead of only two capacitors there are three in a circuit whose most usual form is shown by Fig. 16-6. Such a circuit will furnish the 12,000 to 13,000 anode volts required by picture tubes larger than the 10-inch size.

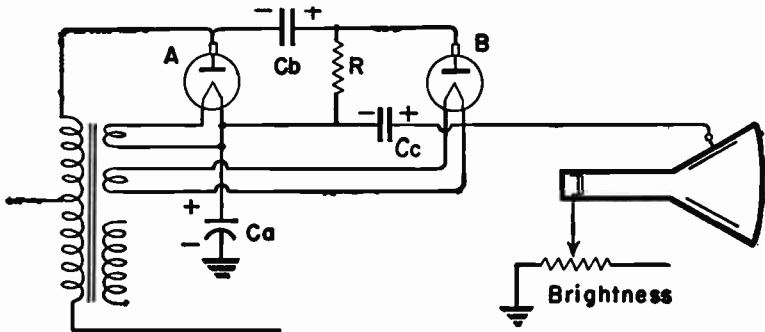

Fig. 16-6.—Voltage doubler circuit as used with flyback power supplies in television receivers.

Each high-voltage pulse makes the plate of rectifier A positive. This rectifier conducts, and capacitor C_a is charged in the polarity marked. This charge is due to pulse voltage supplied from the transformer. At the end of the pulse the plate of rectifier A becomes negative and remains so until another pulse, thus keeping this rectifier non-conductive during the interval. During this interval between pulses part of the charge from C_a passes through resistor R and builds up a charge on the capacitor C_b in the polarity marked. That is to say, during this interval there is a decrease of charge on C_a and an increase on C_b .

Now we may consider the next positive pulse from the transformer. Actually, all that is being described as happening during any pulse in separate parts of the circuit happens during every pulse in all the parts, but it is easier to think of one thing at a time. Because of the positive potential on the side of C_b which is toward the plate of rectifier B this plate becomes positive, there is conduction in rectifier B, and capacitor C_c is charged. Capacitor C_c is, in effect, being charged from the charge which has been placed upon capacitor C_b .

Turning next to the anode circuit of the picture tube, we find this circuit to include the following: Anode to the positive side of capacitor C_c , then from the negative side of C_c to the positive side of capacitor C_a , from the positive side of C_a through ground, the brightness control resistor, and to the cathode of the picture tube. Capacitors C_a and C_c are in series with each other, and the polarity of their charges is such that the voltages add together. These two capacitors have been separately charged by the action previously outlined, but they discharge in series and furnish to the picture tube a voltage much greater than from either capacitor alone and much greater than obtainable from a single rectifier in the conventional circuit.

Oscillator High-voltage System.—Fig. 16-7 is a circuit diagram for a high-voltage power supply employing an oscillator whose output is stepped up by a transformer and rectified by a second tube. Systems of this general type are used in receivers having either electrostatic or magnetic deflection picture tubes, but are more commonly employed in connection with electrostatic picture tubes.

Oscillator frequencies range all the way from somewhat below 100 kilocycles up to around 350 kilocycles. The oscillator tube most often is a beam power type or a power pentode. There may be two oscillator tubes in parallel. A beam power or pentode tube sometimes is connected to operate as a triode.

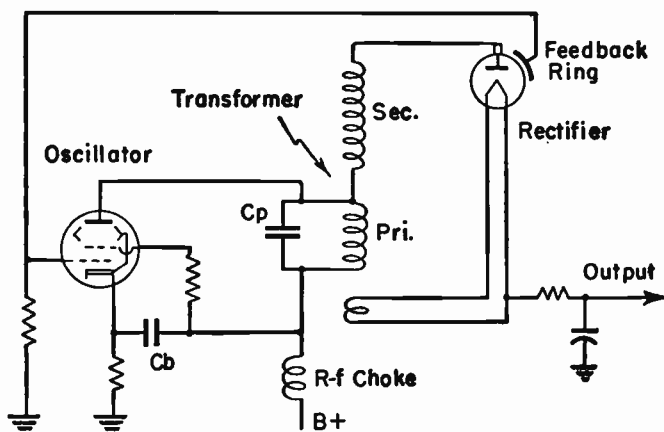

Fig. 16-7.—High-voltage power supply consisting of r-f oscillator, step-up transformer, and rectifier.

At the high frequencies employed in these systems the transformer may be an air-core type, of high-Q construction with minimum distributed capacitance. The step-up ratio, primary to secondary, may be as much as 35 to 1. This requires a secondary of many turns. The resonant frequency of the secondary is that corresponding to its inductance and the sum of distributed capacitance in the winding, stray capacitance in connections, and the internal capacitance of the rectifier. The primary, of fewer turns, is tuned by means of the paralleled capacitor C_p to a frequency nearly the same as the secondary frequency. The oscillator plate circuit of Fig. 16-7 is completed back to the cathode through capacitor C_b . In other circuits both the plate return and cathode are grounded. Voltage and current for the rectifier filament are taken from one or two turns of insulated wire on the transformer.

The oscillator plate is connected through the transformer secondary to the plate of the rectifier. To provide feedback of plate circuit energy to the grid of the oscillator in Fig. 16-7 there is a small coiled spring placed around the outside of the glass envelope of the rectifier. The diagram shows a commonly used symbol for this general type of feedback. Fig. 16-8 shows the appearance of the rectifier with its feedback spring and the

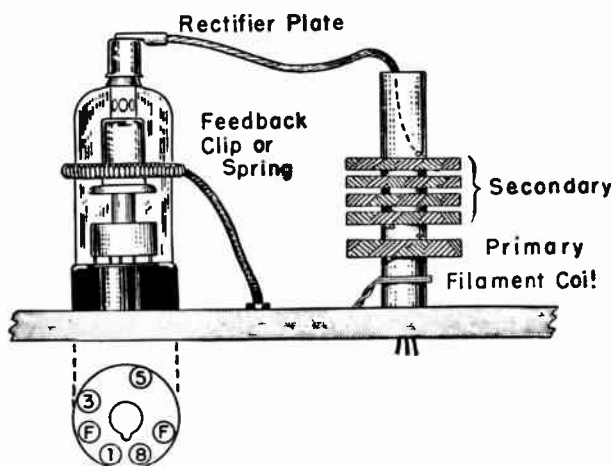

Fig. 16-8.—The 1B3 rectifier and the transformer for an oscillator type high-voltage supply system.

oscillator transformer. The feedback is through capacitive coupling with the spring as one plate, the tube envelope as dielectric, and the current-carrying internal elements as the other plate.

The position of the coupling spring or an equivalent clip on the bulb of the rectifier determines the degree of coupling and varies the feedback when the spring or clip is moved. The usual position is around the approximate center of the cup-shaped plate of the rectifier, or between there and the bottom of the plate. Incorrect positioning will reduce the power output, and may even prevent oscillation from starting when the receiver is turned on.

No one circuit arrangement is particularly typical of oscillator high-voltage systems. Always there are one or more oscillators whose tuned plate circuits are the primaries for a coupling transformer of very high step-up ratio, and there is a half-wave high-voltage rectifier connected to the secondary. Other details are subject to wide variation.

In Fig. 16-9 the feedback to oscillator grid is from a small tickler coil above the transformer secondary winding. In this feedback lead is a grid leak-capacitor combination for providing oscillator grid bias. The plate tuning capacitor C_p is adjustable

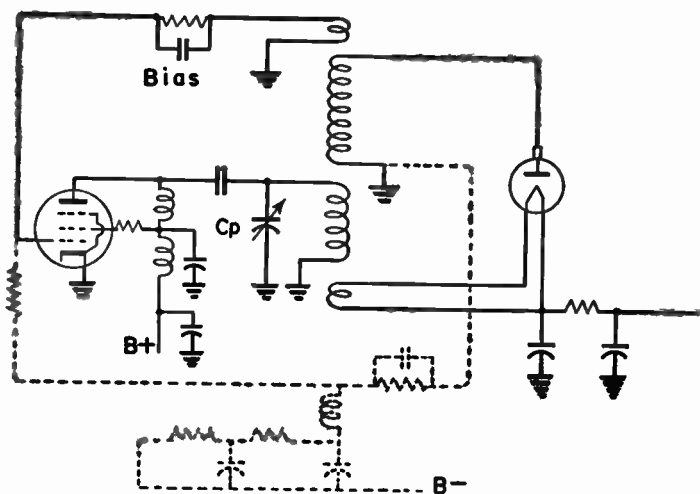

Fig. 16-9.—Oscillator type power supply with adjustment for output voltage and alternative methods of feedback.

for varying the high-voltage output of the system. The low ends of tickler, secondary, and primary transformer windings are grounded, which is equivalent to connecting them together. Return circuits are to the grounded cathode of the oscillator. Between the B+ lead and the screen and plate of the oscillator are r-f chokes with bypass capacitors to ground. These choke-capacitor filters prevent the high oscillator frequency from getting out to the low-voltage B-supply from which the B+ lead is fed.

In broken lines at the bottom of Fig. 16-9 is a different type of feedback circuit, running from the low end of the transformer secondary to the oscillator grid and to B— or ground. Except for the adjustable tuning capacitor for the oscillator plate, none of these variations in the circuit has much effect on servicing.

The more nearly the plate circuit is tuned to the natural frequency of the secondary the higher will be the output voltage to picture tube circuits, this because there is maximum energy transfer from primary to secondary when their resonant frequencies are alike. For stable operation of the oscillator it is advisable to tune the plate circuit to a slightly lower frequency. This may be done by first tuning for maximum output voltage, then increasing the tuning capacitance (capacitor C_p) to obtain slightly lower voltage or to bring the voltage to a value recommended for the receiver. This adjustment can be correctly made only with a high-voltage voltmeter connected between the output and ground.

Because of their high operating frequency it is necessary that oscillator types of high-voltage supply be well shielded to prevent radiation. It is necessary also that the incoming B+ lead pass through one or more r-f chokes, with bypass capacitors to ground or B—, to prevent radiation from the supply lead. If this high frequency gets to the grid-cathode circuit of the picture tube, by way of any of the video circuits, it will produce on the screen a series of closely spaced vertical or diagonal lines.

High-voltage Rectifier.—The rectifier tube or tubes for high-voltage supply systems of all kinds most often is the type 1B3-GT, formerly the type 8016. This is a half-wave rectifier with filament-heater and a top cap for the plate connection. The filament requires a current of 0.2 ampere at 1.25 a-c volts. Should

the filament operate at anything exceeding 1.50 volts, even for a moment, the emission ability will be ruined, even though the filament does not burn out.

The filament voltage rating is based on effective a-c volts. In neither pulse operated nor oscillator types of power supply is there any simple method for making direct measurement of effective a-c voltage on the filament. To insure operation of the filament at a safe temperature dependence is placed on observation of its color or brightness when heated.

To check the operating temperature, in accordance with color, remove the rectifier from its socket or use a similar tube, and connect the filament pins (2 and 7) to a measured potential difference of 1.2 or 1.25 volts either a-c or d-c. Observe the color of the lighted filament in a room which is dark or has only subdued light. The color must be no brighter with the tube in normal operation. The measured testing potential may be obtained from a potentiometer with its ends connected across some low-voltage winding of an a-c power transformer or filament transformer, or connected across a number 6 dry cell, having the filament pins between the slider and either end of the potentiometer. An accurate a-c or d-c voltmeter must be connected to the same points as the filament pins during the test.

Corona Discharge and Flashover.—A corona is a faintly luminous discharge from high-voltage conductors into or through surrounding air spaces. The color is blue, purple, or may be slightly tinged with yellow. This trouble may occur in circuits or parts of power supplies for the high-voltage anode or deflection plates of picture tubes. The exact point of the discharge sometimes may be located by watching the high-voltage parts and conductors with the room dark. If leakage is severe there may be actual flashover between high- and low-voltage conductors.

The effect of corona or flashover on the picture tube screen is somewhat as represented by Fig. 16-10. There are irregular white flashes of various lengths, or, depending on where the leakage originates and to where it proceeds, there may be dark streaks. The effect is much like that of spark or ignition interference, but it will continue with the antenna or transmission line disconnected when due to receiver trouble, and will stop when from outside interference.

There are many possible causes for corona discharge. It may result from excessive collection of dust or dirt around any high-voltage terminals, as at rectifier or picture tube sockets, where conductors are not covered with insulation. There may be too

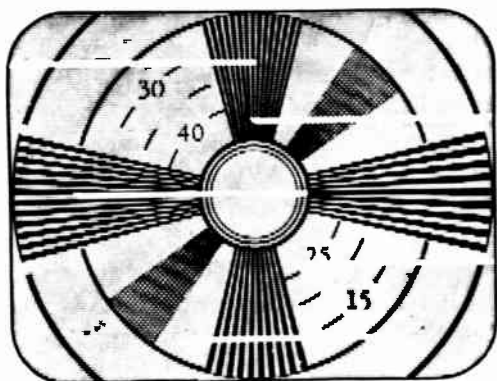

Fig. 16-10.—Corona discharges and flashovers from high-voltage conductors cause streaks in the picture or pattern.

little clearance between such conductors and chassis metal or any other exposed conductors, including connections to bleeder resistors. A spacing of $\frac{3}{8}$ to $\frac{1}{2}$ inch should be the minimum. Corona often will appear at any sharp points which have remained on soldered joints or at socket lugs. Such places should be rounded off if possible, or given a coating of some good coil dope such as the polystyrene or polyethylene varieties.

Corona or sparking may occur if rectifier base pins make poor contact in the socket, also if there are "rosin joints" or other poor connections anywhere in the high-voltage wiring. Less likely causes include defective high-voltage filter capacitors. Effects which are similar to corona on the picture tube may result from amplifier or other tubes being gassy or microphonic.

Low-voltage B-supplies.—Although the high-voltage supplies for picture tube anodes and deflection plates usually are quite different from anything found in sound radio receivers, the television B-supplies for plates, screens, and biasing of other tubes employ much the same principles utilized in radio and such lines as public address.

necessary because the high deflection voltages reach the heater circuit.

There are many transformerless receivers using selenium rectifiers for plate and screen currents where the accompanying voltages are 125 or less. Tubes of practically all types are available in this voltage range. In some receivers there are voltage doublers including either tube rectifiers or selenium rectifiers from which voltages in excess of 200 are obtained without a step-up transformer. Transformerless receivers have tube heaters connected in series, just as in radio. Heater strings are arranged in various series-parallel combinations for tubes requiring heater currents of 0.15, 0.30, and 0.45 ampere, and for picture tubes of types whose heater current is 0.60 ampere. Ballasts are used to prevent current surges when power is applied to cold heaters.

In some receivers employing selenium rectifiers for the B-supply there is a transformer with an insulated primary connected to the line, and with insulated secondaries for the rectifiers and for heater or filament currents. In transformerless receivers the B— side of all circuits connected directly to one side of the a-c power line. As mentioned earlier, these receivers should be tested only while connected to the power line through an isolating transformer. If you have no such transformer, connect between B— of the receiver or chassis ground and a cold water pipe or other building ground an a-c voltmeter capable of measuring line voltage. Then insert the cord plug in the a-c receptacle. If the voltmeter reads line voltage or nearly so, the chassis is hot and the plug must be reversed in the receptacle before connecting any test instruments to the chassis. If the plug is correctly inserted, the chassis or B— will be at building ground potential and the meter will read zero.

Series-parallel Plate-cathode Circuits.—There are many television receivers in which the maximum B-voltage from the power supply filter is applied to groups of tubes wherein cathode current of one group becomes plate current and screen current for the other group. This places the plate-cathode voltage drops of the two groups in series across the power supply, and provides low B-voltages without the use of voltage dividers.

The principle of this method of voltage dropping is illustrated by Fig. 16-12. A conventional rectifier-filter B-power supply is

shown at the lower left. We shall assume that, at the output of this power supply, the potential is 350 volts above ground. This potential is connected to the screen of the audio output tube and, through the output transformer primary, to the plate. We shall assume further, just for an example, that the plate to cathode drop in this audio tube is 200 volts. Then the cathode will be at a potential 150 volts above ground.

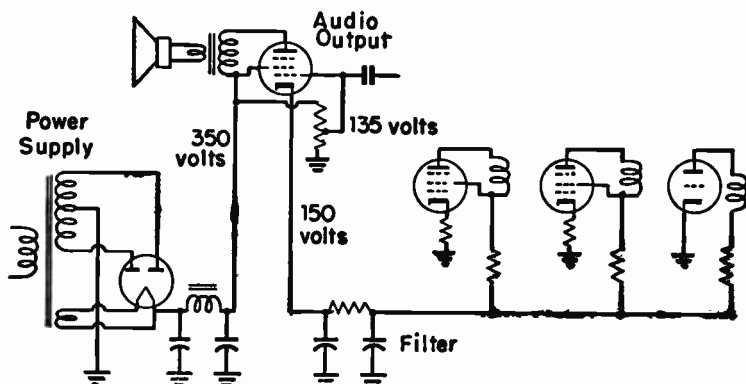

Fig. 16-12.—Three tubes in a parallel connected group which is in series between cathode and ground of an audio output tube.

The cathode line from the audio output tube is run through a resistance-capacitance filter which removes any audio frequencies from the current and voltage. The filtered potential, still at nearly 150 volts, is applied to plates and screens of three tubes shown at the lower right. In these three tubes the drop from plate to cathode and through any cathode resistors takes up the remaining B-voltage, and we come from the cathodes back to ground at zero voltage. Of the total 350 volts from the power supply, 200 volts have been used up on the audio output amplifier, and 150 volts in the cathode filter and the other three tubes.

In order to provide grid bias suitable for the audio output tube its grid return is to ground through a voltage divider connected to the plate supply line. The grid return connection is shown as providing 135 volts at the grid. This is 15 volts below the cathode potential of 150 volts, and makes a negative grid bias of 15 volts. Any other bias could be furnished from the divider connection made to a suitable point. In system such as this we encounter grid

voltages which are far above ground potential, yet have negative grid biases with reference to the cathode of the same tube.

Obviously, the total of plate current and screen current in the audio output tube of Fig. 16-12 must be exactly the same as the total of plate and screen currents in the three tubes fed from the cathode line. To have equal currents in the series-connected groups there may be any number of tubes in each group. Sometimes there are only two tubes in series across the B-supply, or there may be two or more tubes in either or both groups so long as currents may be the same for both groups.

Fig. 16-13 shows an extension of the method of using some tubes to drop the plate and screen voltages for others, and in the same diagram shows some other voltage changing methods which have been examined previously. Beginning with a single power supply transformer and rectifier, there are provided for various plates, screens, and anodes voltages of 420, 350, 245, and 130, also 9,000 volts for the picture tube, without using voltage dividers. To simplify the diagram, the plate loads are shown merely as resistors or coils, while grid and coupling circuits are omitted altogether.

Line A from the power supply filter furnishes 375 volts for plates of the sound and audio amplifiers and the audio output tube, also for the screen of the sound i-f amplifier. The drop across these tubes, from plates and screens to cathodes, is 245 volts. That is to say, this group of tubes is working on an effective plate and screen supply voltage of 245. All their elements, including the grids, are at voltages of 130 or more above ground potential.

The 130 volts from the cathodes of this top group of tubes is filtered by resistor *Rf* and capacitor *Cf*, and is applied to plates and screens of three video i-f amplifiers and also to the plate of the video amplifier. Cathodes of this second group of tubes connect through biasing resistors to ground.

From farther along in the power supply filter we have line B which furnishes 350 volts to the following: Plate of vertical output amplifier. Screen of horizontal output amplifier. Screen of video amplifier and through a resistor to the plate of this tube, in addition to voltage from the cathode feed. Second grid of the picture tube. Plate of the damper tube.

occurs in the tube carrying most of the current for the first group. In Figs. 16-12 and 16-13 this heavy-current tube is the audio output amplifier.

If there is any change of plate-screen voltage for the tubes fed from the cathode line this change exists also at the cathode of the audio output tube. A change of cathode voltage means a change in grid bias, which is the average voltage difference between grid and cathode. A change of grid bias changes the plate and screen currents in the audio output tube, whose sum is the total current for tubes fed from the cathode.

For an example, assume that there is a decrease of plate-screen voltage on the tubes fed from the cathode line and, of course, the same drop at the cathode of the audio output tube. This means a smaller difference between cathode and grid voltages on this tube, a less negative grid bias, and more current through this tube. The result is an increased voltage drop between plates and cathodes of the tubes down below, the tubes fed from the cathode line. The action began with a decrease of this plate voltage, and the increase corrects the condition. The effect is to maintain a fairly constant plate and screen voltage for tubes fed from the cathode line. These fed tubes usually include the video i-f and output amplifiers, and often the r-f, mixer, and oscillator tubes in the tuner.

Chapter 17

TELEVISION ANTENNAS

In the early days of radio broadcasting everyone who expected to have good reception erected an outdoor antenna 50 to 100 feet long. Today most local radio stations can be received very well with no antenna at all, and even for considerable distances we use antennas built into the receiver. History seems to be repeating to some extent in the field of television. Many television receivers are designed to operate with a built-in antenna when within reasonable distances from transmitters. There are, however, few television receivers which will not produce better pictures when operated with an outdoor antenna if very far from the transmitters.

The distance from a transmitter at which it becomes necessary to use an outdoor antenna depends not only on the receiver but on many other factors as well. A few of these factors are: The particular channels or frequencies used by available stations and the radiated power of these stations. The kind and height of buildings and other structures between transmitter and receiver, and the contour of intervening land. The number and kind of electrical machines and devices which are in operation near the

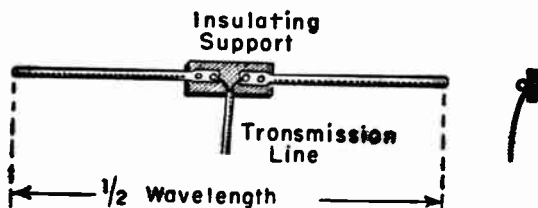

Fig. 17-1.—A simple half-wave dipole antenna for television.

receiver. The type of building in which the receiver is located, where the receiver is placed in that building, and whether the location is on a plain, in a valley, or on a hill. Maximum distance for satisfactory reception without an outdoor antenna may be anything between five or six miles and twenty miles or even more.

This chapter is concerned with some methods of getting the most from an outdoor antenna when this type must be used. Often there will be one channel from which reception is poorest, and it is a service problem to get the most from that channel without sacrificing too much of the signal strength from other channels. It will be impossible even to mention all of the many varieties of antenna design, but we shall deal with principles common to most of them.

Dipole Antennas.—The basic form of television antenna is the half-wave dipole, usually constructed about as shown by Fig. 17-1. The overall length is, theoretically, one-half the wavelength of the carrier signal to which the antenna is to have maximum response. When the electrostatic field of that carrier wave is of maximum positive potential at one end of a half-wave antenna it will be of maximum negative potential at the other end. The result is maximum signal current in the antenna, the connected transmission line, and the antenna input circuit of the receiver.

Note that this simple straight dipole is rather sharply tuned to the wavelength or frequency for which it is cut. Fair results will be had on adjacent channels, but this is not a broad band antenna suited for reception throughout the entire low-band or the entire high-band channels in the television spectrum. In a second or third channel from the one for which tuned the response will be down to around 30 to 40 per cent of the maximum for the tuned channel.

The most generally used broad band antenna is the folded dipole of Fig. 17-2. This consists of a continuous metallic tube looped at the outer ends and with one side having a gap across

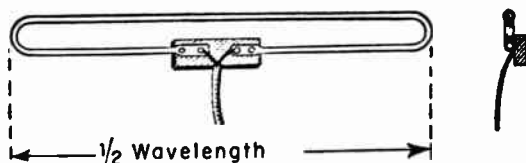

Fig. 17-2.—A half-wave folded dipole, a broad band antenna.

which the transmission line is connected. The two parts of the loop are mounted in a vertical plane. The folded dipole is another half-wave type, its maximum dimension being approximately half of the carrier wavelength to which the antenna is to have

maximum response. Although the folded dipole is thus tuned to a particular wavelength or channel frequency, its response is sufficiently broad that all channels in either the low or high television bands may be handled with a single unit or element.

Antenna Length and Wavelength.—When a half-wave dipole antenna is intended for reception from all the low-band channels or from all the high-band channels, the overall length of the antenna often is based on a wavelength at the center of the band. In the high-band group of television channels number 10 is at the center, so the antenna length might be made suitable for channel 10. Because of unequal spacings between low-band channels no one of them is in the center of this band, although number 4 is approximately so.

If reception is known to be more difficult in some one channel of a band, the antenna length might be made just right for that particular channel. This would help obtain more uniform results throughout the band.

The accompanying table lists overall lengths for either simple or folded dipoles suited to each channel and to the mid-frequency of the low-band channels. The frequency for each channel is taken as being half way between the video and sound carriers. Because of capacitance effects in the antenna, the length is made about 8 per cent less than a half wave. The table lists also the approximate lengths in space of full waves, half waves, and quarter waves. These other dimensions are useful in various computations relating to antennas and transmission lines.

ANTENNA LENGTHS AND WAVELENGTHS

Chan- nel No.	HALF WAVE		WAVELENGTH		HALF WAVE		QUARTER WAVE	
	DIPOLE							
	Feet	Feet and inches	Feet	Feet and inches	Feet	Feet and inches	Feet	Feet and inches
2	7.87	7 11-5/16	17.12	17 1-7/16	8.58	8 6-3/4	4.28	4 2-3/8
3	7.13	7 1-9/16	15.50	15 6	7.75	7 9	3.87	3 10-7/16
4	6.51	6 6-1/8	14.16	14 1-15/16	7.03	7 1	3.54	3 6-7/16
band Mid-	6.33	6 4	13.76	13 9-1/8	6.83	6 10-7/16	3.44	3 5-5/16
5	5.70	5 3-3/8	12.35	12 4-11/16	6.19	6 2-3/16	3.10	3 1-5/16
6	5.20	5 3-5/8	11.52	11 6-1/4	5.78	5 9	2.88	2 10-7/16
7	2.55	2 6-5/8	5.55	5 6-9/16	2.77	2 9-1/4	1.39	1 4-5/8
8	2.47	2 5-9/16	5.36	5 4-7/16	2.68	2 8	1.34	1 4
9	2.39	2 4-3/4	5.20	5 2-3/8	2.60	2 7-3/16	1.30	1 3-9/16
10	2.32	2 3-3/4	5.04	5 0-3/8	2.52	2 6-1/4	1.26	1 3-1/8
11	2.25	2 3	4.89	4 10-5/8	2.44	2 5-5/16	1.22	1 2-11/16
12	2.18	2 2-3/16	4.75	4 9	2.37	2 4-1/2	1.18	1 2-1/4
13	2.12	2 1-7/16	4.61	4 7-5/16	2.31	2 3-11/16	1.15	1 1-13/16

Directional Effects.—Any dipole antenna whose opposite sides lie in a straight line has maximum sensitivity or response to

signals coming along lines which are at right angles to the length of the antenna. This is shown by Fig. 17-3 for a folded dipole. There is the same directional effect with a simple dipole and with other combinations of elements provided all elements extend in a single vertical plane. There is minimum sensitivity or response to signals coming in line with the length of the antenna.

In a locality where the desired signals are strong there will be ample response even though the antenna is turned quite a ways

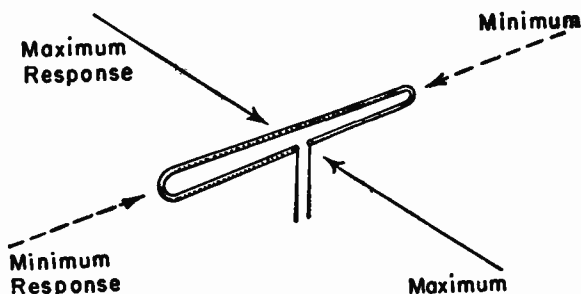

Fig. 17-3.—Maximum response of a dipole antenna is at right angles to its own length.

from a position at right angles to the direction of signals. Then it usually is more important to turn the antenna for minimum response to undesired signals or to sources of electrical interference than to turn it for peak response on desired signals. If the desired signal or signals are weak it is of great advantage to get the antenna turned broadside to these signals. A change of 10 or 15 degrees either way from the peak position will cause a noticeable decrease in signal strength. Where a single dipole must receive signals from several stations in different directions the antenna should be rotated to bring the weakest signal to maximum possible strength.

Reflectors and Directors.—Fig. 17-4 shows a reflector element mounted parallel to a folded dipole on the side of the dipole opposite to that from which maximum signal strength is desired. The reflector may be a continuous length of tubing or it may be divided for convenience in manufacture and assembly. The reflector may or may not be insulated. It has no electrical connection of any kind to the antenna, the transmission line, to ground, or to anything else. The overall length of this tubing is somewhat greater than of the antenna element. Usually the

reflector length is equal to a half-wavelength as listed in the preceding table. The same type of reflector may be used with a simple straight dipole antenna as with the folded type illustrated.

The effect of the reflector is to make a very considerable increase of sensitivity in the "forward" direction and a great de-

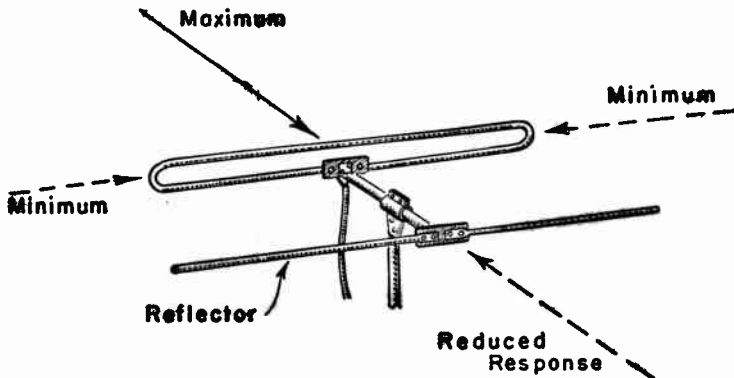

Fig. 17-4.—A folded dipole with reflector element.

crease in the opposite direction, also to make the antenna system more directional so that there is maximum response through a narrower angle than without the reflector. The reflector is used to bring up signal strength from one direction or in one channel, to reduce or eliminate interference from the opposite direction, or for both purposes.

The reflector usually is spaced a quarter-wavelength back of the antenna proper. Such spacings are listed in the table of wave-

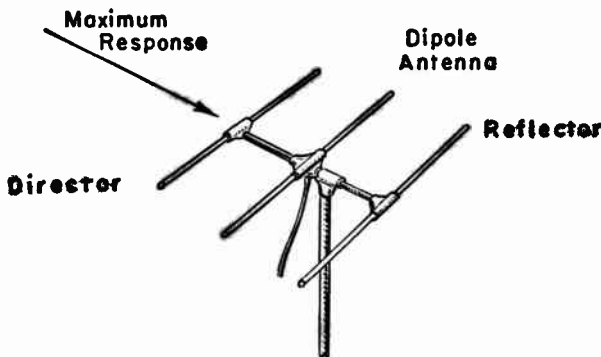

Fig. 17-5.—A simple dipole with director and reflector elements.

lengths. If this spacing is made less than a quarter-wavelength there is a narrowing of the frequency band, a reduction of signal strength from all channels other than the one for which the antenna and reflector are tuned or cut. Most reflectors are simple straight lengths of tubing. If the reflector is of the same form as a folded dipole the frequency response becomes broader than with a straight reflector. That is, the signal strength will be made more nearly equal from channels of higher and lower frequency than the one for which the elements are cut.

In Fig. 17-5 we have a simple straight dipole antenna in between two paralleled conductors. The extra conductor toward the direction from which maximum response is desired is called a director. The conductor which is back of the antenna is a reflector. The director increases response to the desired signal, adding further to the increase obtained from the reflector, and makes the frequency response somewhat narrower.

Usually the director is made about 5 per cent shorter than the antenna in overall length, and is spaced $\frac{1}{4}$ wavelength in front of the antenna element. If the director is moved closer to the antenna element there will be still more increase in forward gain and a further narrowing of frequency response until reaching a spacing somewhere around $\frac{1}{8}$ wavelength. Slightly more gain and a narrowing of frequency response result from making the director of the same length as the antenna element. The antenna element itself may be a simple dipole, as illustrated in Fig. 17-5, or it may be a folded dipole. The folded dipole gives a much broader frequency response than the simple dipole.

Two-band Antennas.—Wherever signal strength is low enough to require use of an outdoor antenna it ordinarily is necessary to use one element or set of elements for the low-band channels and a separate element or set of elements for the high-band channels. The response of a single unit seldom is broad enough to cover the two widely separated frequency bands. The two antenna systems may be of any type. The same general style of construction, except for lengths, may be used for both bands, or the low-band system may be of one type and the high-band system of a different type according to differences between requirements or signal responses in the two bands.

Most two-band antenna systems employ folded dipoles for the

active receiving elements and straight tubing for reflectors. The high- and low-band arrays may be one above the other, as in Fig. 17-6, with a reflector element for each of the folded dipoles. Usually the shorter high-band array is above the low-band array, but this arrangement may be reversed.

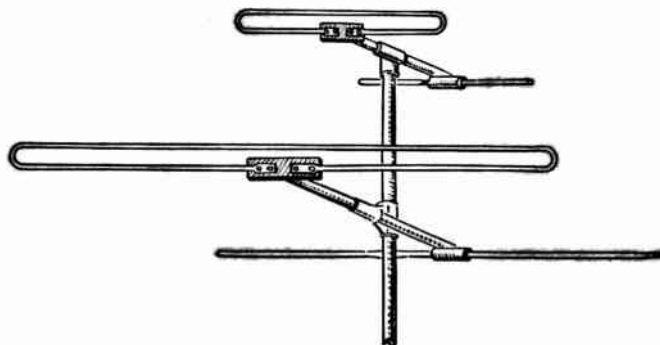

Fig. 17-6.—A dual antenna system with the high-band elements above the low-band elements.

In another general type of two-band design, shown by Fig. 17-7, the high-band folded dipole is mounted in front of the low-band folded dipole element, and a single straight reflector element is placed back of the low-band dipole. This "straight-line" arrangement is satisfactory when all stations to be received are in the same direction from the receiver location. The vertical arrangement (Fig. 17-6) permits the low-band array to be

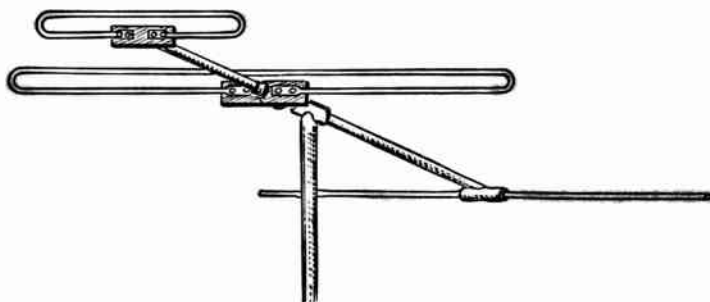

Fig. 17-7.—Dual antenna with the high-band element in front of the low-band element and with a single reflector at the rear.

turned for stations in one direction and the high-band array to be turned in a different direction for other stations.

Usually a single transmission line is run from both elements of a two-band antenna to the receiver. The two elements are connected together by a link made of transmission line. If the length of the link and its connections to the two elements are as originally assembled or in accordance with instructions of the manufacturer they should not be altered. With the correct length and connections of the link, the two antennas will not react to greatly lessen the signal strength from either one. If alterations are made, the signals from the two elements may be in such phase relation as to either assist or oppose their voltages. Although the two antenna lengths are for widely different frequencies, both pick up some signal voltage in any channel to which the receiver may be tuned.

Fig. 17-8 shows possible changes of connections for high- and low-band elements connected together by a link, and to the

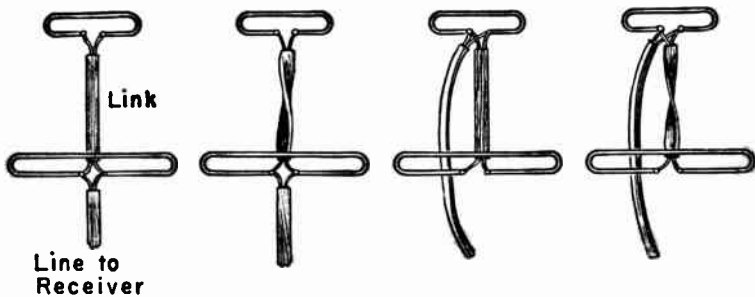

Fig. 17-8.—Four possible connections of transmission line to high-band and low-band antenna elements.

receiver through a transmission line. The link may run straight or be twisted a half turn. The transmission line may be connected to either one of the antenna elements. The connection to use is the one giving the strongest signal on the band where strength is needed.

Instead of connecting the high- and low-band elements to the receiver through a single transmission line, separate lines may be run from the antennas all the way to the receiver. This requires a change-over switch operated by or in connection with the channel selector to bring in the antenna for whichever band is to

be received. There is somewhat better response in each band when using two lines and two antennas than when using a single line for both antennas.

Stacked Dipoles.—Fig. 17-9 shows front views of antennas called stacked dipoles or H-type antennas, the latter name because the form is that of a capital H lying on its side for the horizontally polarized television waves. The unit at the left is essentially two simple dipoles joined together with parallel tubes

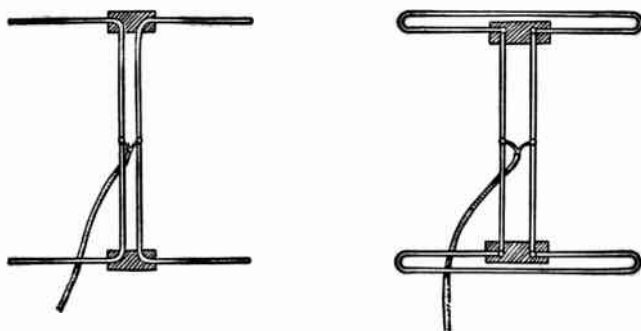

Fig. 17-9.—Stacked dipoles or H-type dipoles.

between the center gaps. At the right are two folded dipoles similarly joined at their center gaps. The two sides of the transmission line are connected midway between top and bottom to the two vertical tubes.

Compared with a single simple dipole or a single folded dipole this H-type has more gain at the frequency for which the length is cut, and has also a considerably broader frequency response. The folded type has response broad enough for a single H-unit to work in both television bands, provided signals are strong in either one band or the other. The length is cut for channel 7 if signals are weakest in the high band, or for channel 6 if signals are weakest in the low band. There is maximum gain when the distance between top and bottom elements is a half-wavelength in the channel for which the units are cut. To lessen the overall size, this vertical spacing often is reduced to as little as a quarter-wavelength for the low band, but at some sacrifice in gain.

The stacked array often is used where there is severe electrical

interference because, compared with most other types, there is greater rejection of interference impulses coming from either above or below the antenna. This is the type of interference due to flashing signs, diathermy apparatus, auto ignition systems, and other electrical devices. Reflectors usually are placed behind each element. Directors sometimes are added in front of each element. Reflectors and directors have the same effect as with other antennas in increasing gain and making more pronounced directional effects.

Impedance Matching.—A signal reaching an antenna induces voltage and current which represent some certain amount of power. It would be highly desirable to transfer all this power to the receiver input circuit, but there is unavoidable loss in the high-frequency resistance of any transmission line. In addition there are losses, largely avoidable, due to not having the impedance of the line matched to the impedance of the antenna and/or to the impedance of the receiver input circuit. Losses due to mismatching of impedances result in "snow" and all the other characteristics of a weak signal, including a generally weak picture, poor definition, and even multiple images or "ghosts."

The impedance at the center gap of a half-wave simple dipole antenna is approximately 73 ohms at the frequency for which the antenna is cut and if the antenna is far enough from all surrounding objects that they do not affect inductance or capacitance. Under such conditions the antenna impedance would consist of resistance alone, without inductive or capacitive reactance. The impedance at the gap of a folded dipole under similar conditions is about 300 ohms. At frequencies other than that for which the antenna is cut the impedance will be higher, but it will not change proportionately to frequency. For signals of higher frequency the antenna impedance will have an excess of capacitive reactance, and at lower frequencies will have an excess of inductive reactance.

The impedance of a transmission line is not affected by the same factors which affect antenna impedance. Line impedance depends on inductance and capacitance per unit length of line and on the dielectric constant of whatever insulation is used for protection and support. This characteristic impedance of a line of given construction is not altered by any change in length of

line, nor is it altered by variations of frequency—because frequency has no effect in inductance, capacitance, or dielectric constant.

Standard types of ribbon or twin-lead transmission line, with two parallel insulated conductors, are available with impedances of 75 ohms, 100 ohms, 150 ohms, and 300 ohms. The 300-ohm line is used with receivers having a 300-ohm input circuit balanced to ground. The 100-ohm and 150-ohm lines are used for matching sections and other special purposes. The 75-ohm line may be used between a simple straight dipole antenna and a receiver having a 75-ohm balanced input, which would be an unusual combination.

The unshielded ribbon or twin-conductor lines may have considerable capacitance to ground when run near any kind of conductive materials. This would change the impedance and increase power loss. Available also is shielded twin-conductor cable of 300-ohm impedance. It consists of individually insulated wires surrounded by a braided shield, with the whole protected by outer insulation. This type is used with 300-ohm balanced input receivers where there is considerable electrical interference or where the line must run close to metal objects. The shield is grounded.

Coaxial transmission line of 75-ohm impedance is used between simple dipoles and receivers whose input circuit is of 75-ohm impedance, not balanced, but connected on one side to ground. The central conductor of the coaxial cable is connected to the antenna terminal and the cable shield to the ground terminal. At the antenna end the central conductor is connected to one side of the dipole and the shield to the other side. Since the coaxial line is shielded it may be run close to or on metallic materials. It reduces the effect of electrical interference because of the grounded shield.

Many practical applications of impedance matching are more easily understood if we think of any antenna and any receiver input, represented at the left in Fig. 17-10, as equivalent to two parallel tunable circuits at the right. If the antenna is tuned to a received signal frequency, by cutting to a suitable length, the inductive and capacitive reactances cancel leaving only resistance and there is maximum voltage across the parallel circuit. This

remaining resistance is the impedance of the antenna, 73 ohms, 300 ohms, or whatever it may be.

If the receiver input circuit is tuned, by design, for resonance at the frequency coming from the antenna, here again we have canceling of reactances and a remaining resistance which is the input impedance of the receiver. If line impedance is the same as impedances of antenna and receiver there will be maximum

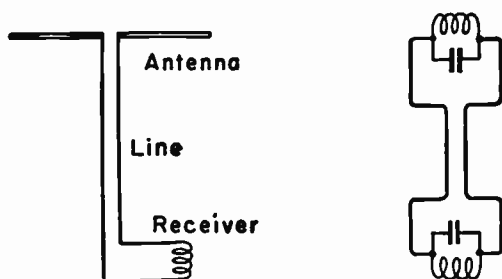

Fig. 17-10.—The antenna and receiver input circuit act somewhat like tuned parallel resonant circuits.

transfer of signal energy or power from antenna to receiver.

The behavior of a tuned circuit when there is change of frequency is shown by the familiar curves of Fig. 17-11. At frequencies below resonance the capacitive reactance is greater than the inductive reactance, the circuit has an excess of capacitance effect. At frequencies higher than resonance there is excess inductive reactance and excess inductance effect.

When alternating current flows in a pure inductance the result is merely a conversion of energy into an expanding magnetic field, which then collapses to return all energy to the line and source. When alternating current flows in a pure capacitance there is charging, followed by a discharge which returns all energy to the line or source. No power is absorbed in inductance or capacitance. Energy goes from the source (antenna) to the load and all of it is reflected back. Consequently, in the circuits of Fig. 17-10, the farther we get from the resonant frequency the more of the available signal power or energy is reflected back to the antenna and the less goes to reproduce pictures and sound in the receiver.

The transmission line possesses inductance and capacitance,

and their reactances, in addition to its conductor resistance. If the line impedance does not match the impedances of both antenna and receiver there are reflections at the junctions, and signal power goes back to the antenna rather than to the receiver. Even a high-resistance joint in a line, or a change of

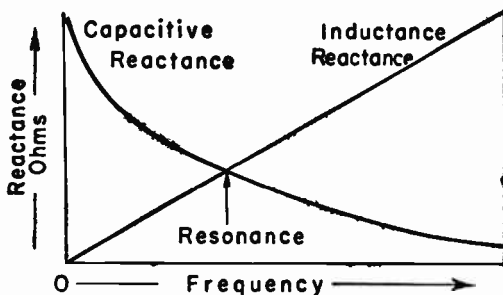

Fig. 17-11.—Variations of capacitive and inductive reactances below and above the resonant frequency.

conductor spacing or other mechanical dimensions will change the impedance at that point and there will be reflections with accompanying loss of power going to the receiver.

Fortunately, short pieces of transmission line have all the properties of tunable parallel circuits or tunable series circuits, and their tuning as well as excesses of inductive and capacitive reactance may be varied by changing the length of the piece of line. Suitable lengths of line may be used to compensate for many mismatches of impedance, by adding whichever kind of reactance is needed to bring back the equivalent of resonance at a junction. Short sections of lines may be used also like impedance matching transformers.

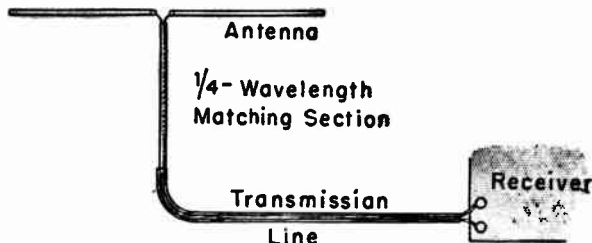

Fig. 17-12.—An impedance matching section between antenna and transmission line

An antenna of one impedance may be matched to a transmission line of different impedance with a quarter-wavelength section of line as in Fig. 17-12. The matching section, connected between the antenna and regular transmission line, is cut to a length equal to a quarter-wavelength at the signal frequency for which the antenna is cut. Quarter-wavelengths are listed in a preceding table.

The length as taken from the table must be corrected for the velocity constant of the kind of line used as a matching section. The velocity constant is the fraction or percentage of wave velocity in air at which the signal waves travel in the line. Waves always are slowed down to a greater or less extent in any kind of line. Constants for a particular line are given by manufacturers, usually on the package. For a generally used unshielded twin-lead type of line the constant for a 300-ohm line is approximately 0.82, for a 150-ohm line it is 0.77, and for a 75-ohm line it is 0.69. Multiply the quarter-wavelength listed in the table by the velocity constant to determine the actual length of matching section.

The impedance required in the matching section is equal to the square root of the product of the antenna impedance and transmission line impedance, thus:

$$\text{Matching } Z = \sqrt{\text{antenna } Z \times \text{line } Z}$$

Here is an example of matching a 73-ohm antenna to a 300-ohm line. The product of 73 and 300 is 21,900. The square root of 21,900 is 148, which should be the impedance in ohms of the matching section. A piece of 150-ohm line would be satisfactory. To continue the example, assume that weakest reception is in channel 8. The earlier table gives 1.34 feet as a quarter-wavelength for this channel. If the velocity constant of our 150-ohm line is 0.77 we multiply 1.34 feet by 0.77 to find 1.03 feet as the required length to be inserted between antenna and transmission line.

The 150-ohm line would do also for matching a 300-ohm folded dipole to a 73-ohm line, since the square root of the products remains unchanged. The length of the matching section always depends on the channel or frequency at which the best matching is desired.

When a receiver has an untuned antenna input circuit the impedance is designed for a fair average match throughout the entire television spectrum, or through an entire band if there are separate inputs for high and low bands. If reception in one channel is particularly weak it may be improved by using a matching stub on the antenna terminals of the receiver, as shown by Fig. 17-13.

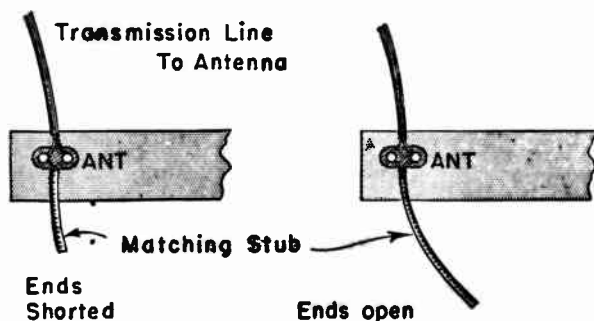

Fig. 17-13.—Matching stubs on antenna terminals of receiver.

The stub is a piece of transmission line of the same kind used between the receiver terminals and the antenna, connected to the same terminals as the transmission line. The two conductors at the free end of the stub may be connected together or shorted as at the left, or they may be left entirely open, as at the right. The length of a shorted stub will be approximately a quarter-wavelength for the channel or frequency at which best matching is wanted, and for an open stub this length will be approximately a half-wavelength. Velocity constant need not be considered, because adjustment is literally a matter of cut and try for best results.

A fairly easy way to adjust a shorted stub is to use a piece of line somewhat more than a quarter-wavelength long and strip off the insulation from the outer sides of both conductors. Then use a wire clip which can be slid along the two conductors as an adjustable short circuit. When the position for best reproduction is determined by experiment, make up a new piece of line with its free ends shorted at the required point and attach this new piece to the antenna terminals.

To adjust an open stub, commence with a piece somewhat longer than a half-wavelength for the channel where reception is to be improved. Then clip off not more than $\frac{1}{4}$ inch at a time. The picture will become brighter and, after cutting off some length of stub, will commence to dim out again. Make up a new stub of the length which caused maximum brightness and connect it to the antenna terminals.

Antenna Location.—An outdoor antenna should be mounted at the highest practicable elevation. The chief advantage of height for a receiving antenna is in getting away from sources of electrical interference and away from objects which may intercept or absorb signal energy. Height helps also to reach up to a point at which there may be more nearly a "line-of-sight" path between transmitting and receiving antennas without intervening obstructions.

When a probable or possible location has been selected, tests should be made to determine the antenna position which produces maximum signal strength at the receiver. Usual procedure is to have the antenna attached to a temporary mast or section of mast which can be carried about while connected to the receiver through the type of transmission line to be used in the final installation. The receiver should be tuned to the weakest station, or alternately between weak stations. The transmission should be of a test pattern rather than a picture program. One person observes changes of brightness in the pattern while a second moves the antenna.

The antenna should first be held horizontally while slowly rotated about the mast as a center. Maximum signal may be obtained with the antenna broadside to the station direction, or in any other direction. Next, the antenna should be tilted one way and the other. Television waves leave the transmitter horizontally polarized, but may arrive other than horizontally. This rotating and tilting should be repeated with the antenna moved to various locations if this is possible. The pattern at the receiver must be watched not only for maximum brightness but for appearance of multiple images or "ghosts" which are due to direct and reflected waves acting together at the antenna. This effect may be eliminated by correct positioning of the antenna and by the use of reflectors and possibly directors also.

The method just described calls for two persons with some means for talking back and forth. The best means is a pair of phones with a connecting line from antenna location to receiver. The whole job can be done by one man if a portable television receiver is taken to the antenna location, connected to the an-

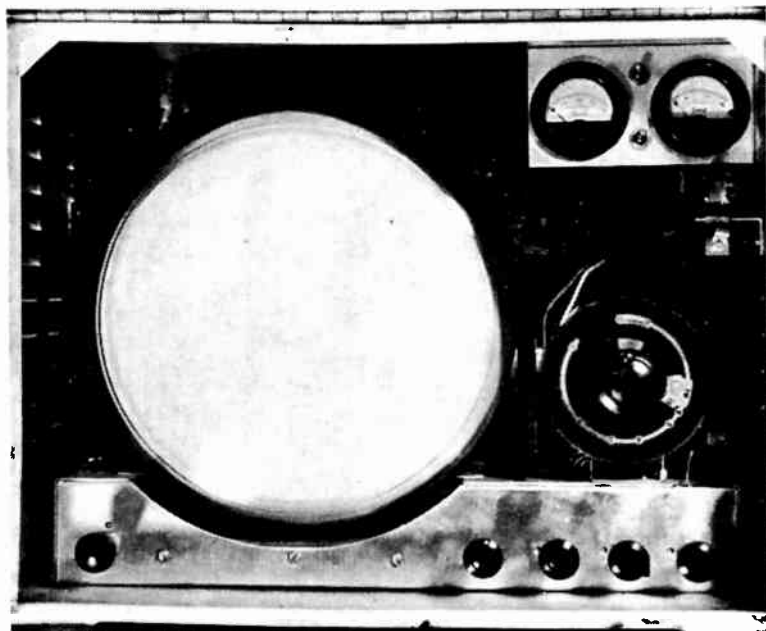

Fig. 17-14.—A Du Mont test set, a television receiver with a signal strength meter, taken to the antenna location while orientation is carried out.

tenna with a transmission line and to a power supply with an extension cord, then watched while the antenna is orientated. Fig. 17-14 shows a receiver designed for such work. It consists of a chassis, picture tube, and two meters in a metal cabinet with a front cover which hinges back over the top. One meter is for measurement of line voltage. The other is a microammeter connected to the grid circuit of the video amplifier for observation of relative field strengths or signal strengths.

With still another method a low-range high-resistance d-c voltmeter is connected through a long flexible cord or cable to chassis ground and the video detector load resistor of the regu-

lar receiver. The meter then is carried to the antenna location and watched for maximum reading as the antenna is moved about and turned in various ways. The meter will indicate relative signal strengths, but will not show the presence of multiple images nor the general quality of the reproduction. These will have to be checked at the receiver after a position of satisfactory signal strength has been found with the help of the portable meter.

If signal strength is about the same from two or more locations, the one to be used is that allowing the shortest length of transmission line between antenna and receiver. Loss of signal strength, expressed in decibels, is directly proportional to length

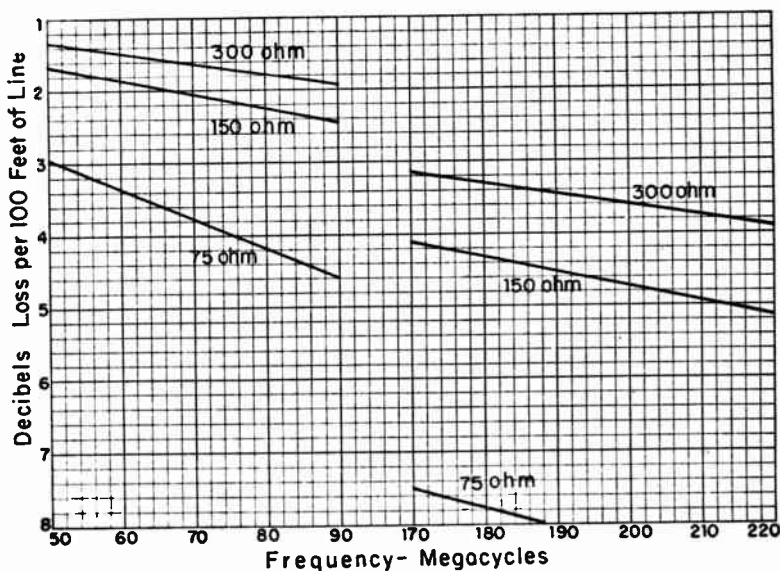

Fig. 17-15.—Losses in three types of twin-lead unshielded transmission line at television frequencies.

of line and increases with frequency. Fig. 17-15 shows approximate losses in decibels per 100 feet for twin-lead unshielded lines of three different impedances when used at frequencies in the television bands. In a long line the losses may well be serious, especially at the higher frequencies and where the signal is weak to begin with.

Antenna Erection.—When installing television antennas for customers it is essential to be acquainted with local rules and ordinances relating to such installations, also with the latest rules of the National Electrical Code for radio antennas, and to investigate any restrictions such as may be imposed by building or apartment leases. Code rules relate to supports of suitable strength, to keeping away from power and light poles, to preventing any possible contact with conductors of lighting and power circuits, and other matters affecting personal safety of users and the public.

A metal mast always should be grounded through heavy copper wire to a cold water pipe or a long rod or pipe driven down to permanently moist earth. The transmission line should run through a lightning arrester approved by the Underwriters' Laboratories, and the arrester should be installed and grounded according to instructions of its makers. Lightning is a distinct hazard if these precautions are not observed.

Instructions for assembly and support come with commercially available antennas. The antenna proper must be at least eight feet from all metallic objects such as pipes, vents, gutters, metal roofs, and such like. Remember that parts of the antenna structure will become loaded with snow and ice to increase their weight, and they will be subjected to strong winds. Guy wires should be used if the total height of the mast is more than about six feet. In addition to making a secure installation this will prevent swaying which causes picture movement, changes of brightness, and maybe loss of sync. If guy wires come up close to the antenna elements, break up the guys with regular antenna insulators two or three feet apart for about the first six to ten feet from the elements.

The ends of the transmission line conductors should be fitted with soldered lugs for attachment to antenna binding posts. Unshielded line should be fastened to the mast, near the antenna, with some form of standoff insulator. From this fastening the line should slope away from the mast, but not at an angle of more than 45 degrees because coming any closer to the horizontal might allow signal pickup in the line. Twist the line about one turn per foot throughout its entire length, this being a further

precaution against signal or interference pickup. Support the line with any of the various standoff insulators made for the purpose, staying away from all large metal objects and making exposed runs taut enough to prevent swaying in the wind.

All types of shielded transmission line have their shields grounded, so they may be clamped or taped to a metal mast and may run close to or on bodies of metal.

Where the transmission line enters the building it should pass through a hole drilled with a downward slope from indoors to outdoors, just as for a radio leadin. The line should be protected with an insulating tube where it goes through a building wall, and must be continuous from outdoors to indoors without the use of any leadin strips or connectors such as often used for radio installations. Leave a drip loop on the outdoor side and close up the opening with caulking compound for weathertightness. The line can be made tight in the insulating tube by a winding of cellulose tape. Do not pinch the line to change conductor spacing. The portion of the line which is indoors may be supported on any non-metallic surface with small pieces of insulation, or an unshielded line may be held with the fewest possible very small brads through the center of the insulation. Do not use metal clamps which enclose an unshielded line, they upset the impedance.

The shield of coaxial line must come as close as possible to the antenna terminals of the receiver, and the connection from shield to ground terminal likewise should be very short. Braiding of the shield may be prevented from opening by winding with small gauge copper wire and lightly soldering this binding wire. Use only a touch of solder, to avoid melting the cable insulation.

It is difficult to splice any type of transmission line without changing the impedance and causing reflections. Better than a soldered splice are the small plug type connectors made with low-loss insulation in which the bared ends of the line conductors are held by clamp screws, with correct spacing between the conductors and pins. The halves of the connector may be tied or cemented together for a permanent joint.

Chapter 18

COLOR TELEVISION

If we have blue light, green light, and red light of the particular varieties called "primaries" for color television, these three may be blended in various proportions to appear to our eyes as any color of the rainbow, or as any color not found in the rainbow, or even as white light. The fact that three primary colors may be blended to give the sensations of any and all colors makes color television simple enough to be practical.

On the viewing screen or phosphor screen of a color picture tube are produced only blue, green, and red lights—nothing else. But if we allow green and red to exist together, without any blue, we see a yellow color in spite of the fact that actually there is no yellow light at all. The impression or sensation of any other color may be produced by one, two, or all three of the primary colors blended in suitable proportions.

The phosphors of a color picture tube emit no white light; there is no white phosphor. Yet a blend of proper proportions of blue, green, and red primary colors appears as white to our eyes. This makes it possible for a color receiver to reproduce black-and-white or monochrome pictures when receiving a black-and-white program. The blue, green, and red primaries are maintained in proportions required for white, while being varied in brightness to produce all the lights and shadows needed for black-and-white pictures.

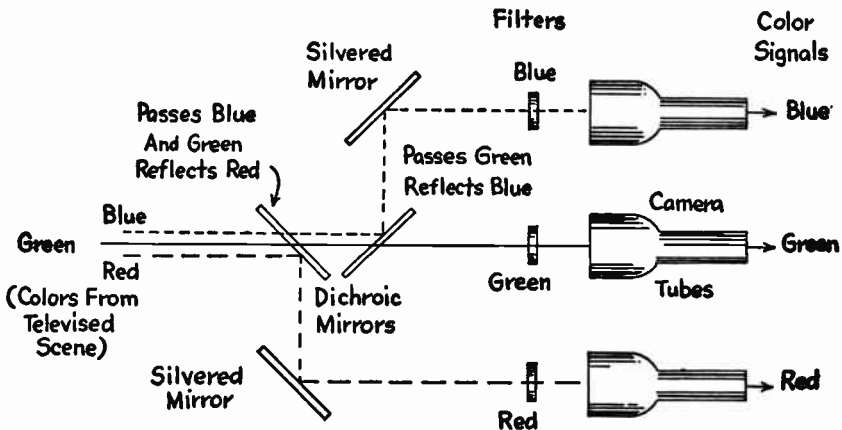

Fig. 1.—Colors are separated into the three primaries at the camera.

At the studio where an original scene is televised in full color the image is picked up by a color camera which may be of the type illustrated in principle by Fig. 1. Inside the camera are three light-sensitive tubes, all alike. Between each tube and the pickup lens is a system of light filters, silvered reflecting mirrors, and dichroic mirrors. These latter reflect some colors while passing others. Into one light-sensitive tube passes only blue light that comes from parts of the scene which are blue or bluish. Into the second tube passes only light that is green or greenish, and into the third tube passes only red or reddish light from the televised scene.

In each camera tube is an electron beam deflected horizontally and vertically to scan its image of one primary color. Output voltage from each tube is proportional to intensity of colored light from the small area of the image traversed or scanned by the electron beam at each instant. Output voltage from the blue camera tube varies with changes of blue light from point to point on the blue image. Similarly, outputs from the green and red tubes vary with changes of green and red light intensities from point to point on the green and red images.

At the outputs of the camera tubes we have a blue signal voltage, a green signal voltage, and a red signal voltage. When these three signal voltages eventually are applied at the picture tube in a color receiver, the original scene with all its coloring will reappear on the viewing screen of the picture tube.

On the viewing screen of the color picture tube are three kinds of phosphors. When struck by an electron beam, one kind of phosphor emits blue light, another kind emits green light, and the third kind emits red light. In the type of picture tube commonly used the three kinds of phosphors are arranged in the form of tiny dots as shown by Fig. 2. The number of phosphor dots in this figure would appear on an area of viewing screen about one-eighth inch square. The entire viewing screen is similarly covered with dots—hundreds of thousands of them.

Note that each dot of any one color is surrounded by dots of the other two primary colors. If you examine any portion of the viewing screen it becomes apparent that every blue dot has immediately below it a red dot at the left and a green dot at the

right, as shown in the small sketch. Such groupings occur all over the viewing screen. Each such group of three color dots is called a trio or a triad.

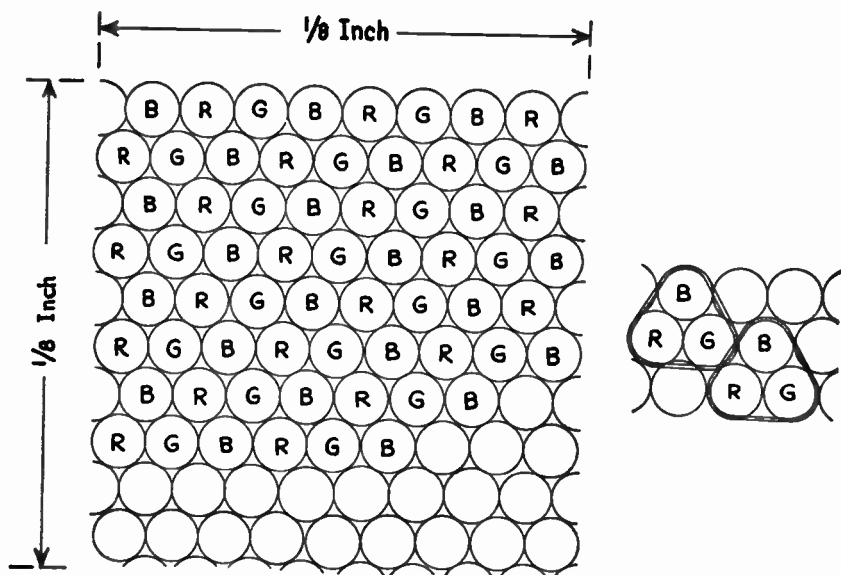

Fig. 2.—How phosphor dots are arranged on the viewing screen of a three-gun color picture tube.

The phosphor dots are so extremely small that they cannot be distinguished separately without a magnifying glass. This small size causes the three colors to blend together in our eyes. Blending is assisted because the impression of a colored light persists in our eyes after the light goes out. What we see, or think we see in the way of color, depends entirely on which phosphor dots are excited by an electron beam, and on how intensely they are excited.

In the neck of the color picture tube are three electron guns, as in Fig. 3. Three sharply focused electron beams from the three guns converge or come together at a small opening in an opaque shadow mask, pass through the opening, then diverge or separate to strike the three different phosphor dots of a group. The beam from the blue gun strikes only the phosphor dots that emit blue light, while the green beam strikes only a green dot, and the red beam only a red dot.

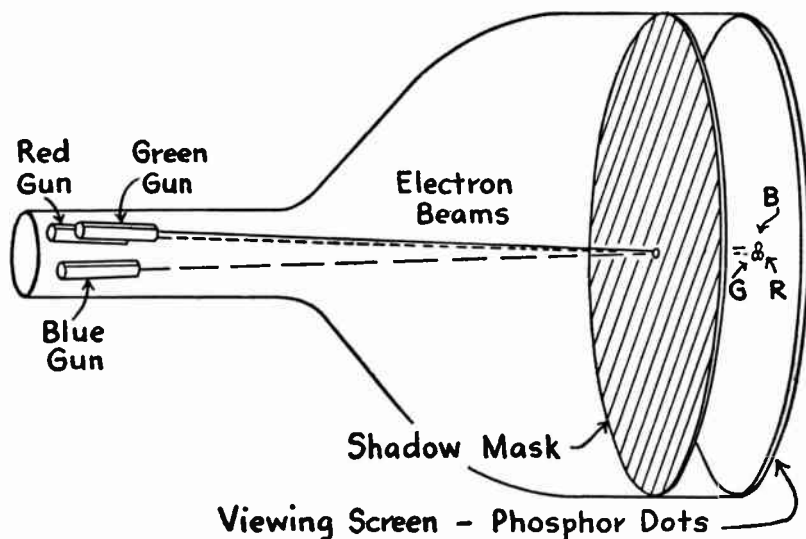

Fig. 3.—Three electron beams from three guns pass through a shadow mask opening and strike the three phosphor dots of a group.

The shadow mask has one small opening for each group of phosphor dots on the viewing screen. Were there 900,000 dots on the viewing screen there would be 300,000 groups, and in the shadow mask would be 300,000 openings.

Since the beam from the blue gun strikes only blue phosphor dots, varying the intensity of this electron beam will completely control the appearance of blue in reproduced pictures. Similarly, the green gun has complete control of green in pictures, and the red gun controls red.

Each of the three guns in the color picture tube is like the single gun of an electrostatically focused picture tube for black-and-white pictures. In each gun there is a cathode, a control grid, an accelerating grid called the screen grid, a focusing electrode, and an anode section which often is called the second anode or ultor in black-and-white tubes. Fig. 4 is a symbol for a three-gun color picture tube.

The three high-voltage anodes are constructed as a single unit and operate at the same high voltage. All three focusing electrodes are tied together internally and operate at the same volt-

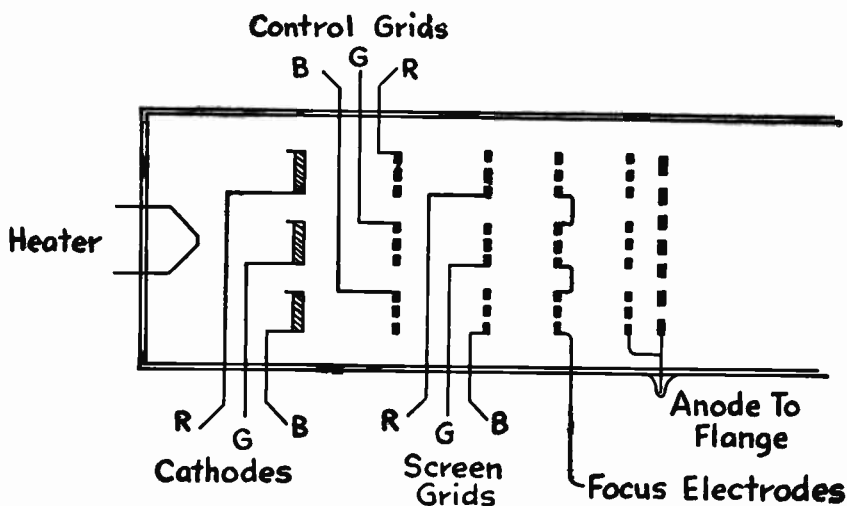

Fig. 4.—The elements in the three electron guns of a color picture tube.

age, which is much lower than anode voltage and suitable for electrostatic focusing. The remaining elements, which are the screen grids, the control grids, and the cathodes, are separate in each gun. They have individual base pins and their voltages may be separately controlled or varied.

Intensity of the electron beam from any of the three guns may be changed by varying the voltages of control grid and screen grid with respect to the cathode, just as in any other kind of picture tube. The control grid is negatively biased with respect to the cathode, while the screen grid always is positive with respect to the cathode.

One of three color-signal voltages is applied between control grid and cathode of each electron gun. Any signal voltage which becomes more negative at a control grid, or more positive at the cathode, will reduce intensity of the electron beam from that gun. Any signal voltage which becomes less negative at the control grid or less positive at the cathode will increase intensity of the electron beam. These actions are no different than in the single electron gun of a black-and-white picture tube.

The three electron beams are simultaneously deflected horizontally and vertically so that all three pass through the same opening in the shadow mask wherever the beams may be directed, and so that each beam strikes phosphor dots of proper color.

As the beam from the blue gun sweeps across the phosphors, its intensity is varied by the blue color signal voltage so that blue phosphor dots emit just the right amount of blue light for each large or small area of the reproduced picture. In similar fashion the green beam excites the green dots and the red beam excites the red dots to put necessary amounts of green and red into every large or small picture area.

Voltage on the screen grid of each gun is not varied by color signals, but is adjusted during servicing to such a fixed value as causes the beam from that gun to have average intensity matching average intensities of the other two beams. Adjustments of screen grid voltages serve to balance the average intensities of the three beams for correct rendition of color and also of black and white in reproduced pictures.

Color Television Signals.—The complete composite signal in the channel used by a station transmitting a color television program consists of the following parts.

1. *Luminance signal.* This signal carries all the variations of brightness for pictures, but really carries no color information. The luminance signal, all by itself, is capable of causing black-and-white pictures to appear on a color picture tube. It will also cause black-and-white pictures on the picture tube of a receiver designed only for black-and-white or monochrome reception, in spite of the fact that the luminance signal originates at a color camera. The luminance signal often is called the brightness signal. Another name is Y-signal.

2. *Chrominance signal.* This signal carries all the information necessary for adding color to pictures whose brightness is varied by the luminance signal. The chrominance signal sometimes is called the chroma signal. It varies the relative intensities of light emitted by the three-color phosphors so that this light blends to form color sensations rather than only the sensation of black, white, and gray.

3. *Sync pulses.* These pulses keep the deflection of the three electron beams in a color picture tube correctly in time with

pictures. The pulses cause horizontal and vertical traces and re-traces at correct instants. There are horizontal sync pulses, serrated vertical sync pulses, and equalizing pulses, exactly like those in a black-and-white or monochrome composite television signal. These sync pulses will control deflection of the single electron beam in a black-and-white picture tube just as they control the three beams in a color picture tube.

4. *Color sync pulses.* These maintain excitations of phosphors, or intensities of electron beams in the color picture tube, properly timed with instants at which beams in the color camera traverse various areas of images in the camera tubes. The color sync pulses are called bursts. They form the burst signal component of the composite color signal.

There is also a frequency-modulated sound signal like that used with black-and-white transmission. This signal is transmitted in the same channel, but otherwise is entirely separate from the picture and sync signals, which consist of amplitude modulation.

From the foregoing explanation of color television signals, and how they act in black-and-white receivers as well as in color receivers, it is apparent that many sections and circuits are alike or nearly so in both kinds of receivers. Before examining the parts of a color receiver which act only on the chrominance and color sync portions of the composite signal, and those parts required only for a three-gun color picture tube, it may be well to discuss the many sections which are practically the same in color receivers as in black-and-white types.

Sections Similar for Color and Black-and-white.—Fig. 5 shows the principal parts of a fairly typical color receiver. Sections represented by unshaded blocks are similar to equivalent sections in a black-and-white receiver. Shaded blocks represent sections concerned with reproduction of color pictures. Following notes are explanatory of sections which are similar in the two kinds of receivers, and will allow omitting later references to these parts.

Antenna. A good broad-band antenna satisfactory for monochrome is also satisfactory for color. A narrow-band high gain antenna may cause trouble. The transmission line should be well matched to impedances of both the antenna and the receiver.

Tuner. The same general types of tuners used for black-and-

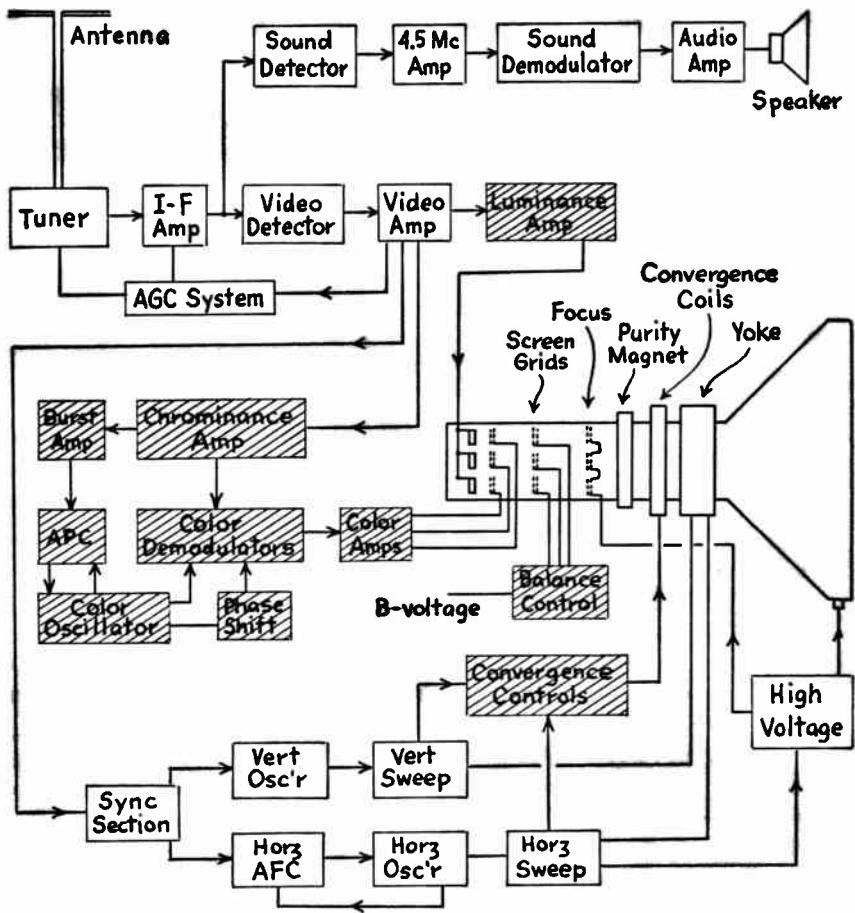

Fig. 5.—Principal sections of a color television receiver.

white are used for color reception. Alignment must be such as allows nearly uniform gain throughout any given channel, without excessive tilt toward either side of the response. If a booster is used it must not cut the channel response on the side toward the sound carrier.

I-f Amplifier. Intermediate-frequency amplifier sections are of the same general design for color and for black-and-white. For color, however, the frequency response should have nearly uniform gain to at least 3.9 mc below the video intermediate fre-

quency, and preferably to 4.0 or 4.1 mc. Otherwise the color signals may be greatly attenuated or may disappear. Usually there are more traps in the i-f amplifier section of a color receiver than in one for a black-and-white set. Alignment of couplings and traps is critical, it must be correctly performed to obtain the frequency response described.

Agc Systems. Automatic gain controls for the i-f amplifier and tuner are alike for color and for black-and-white.

Detectors. Following the i-f amplifier of Fig. 5 is a video de-

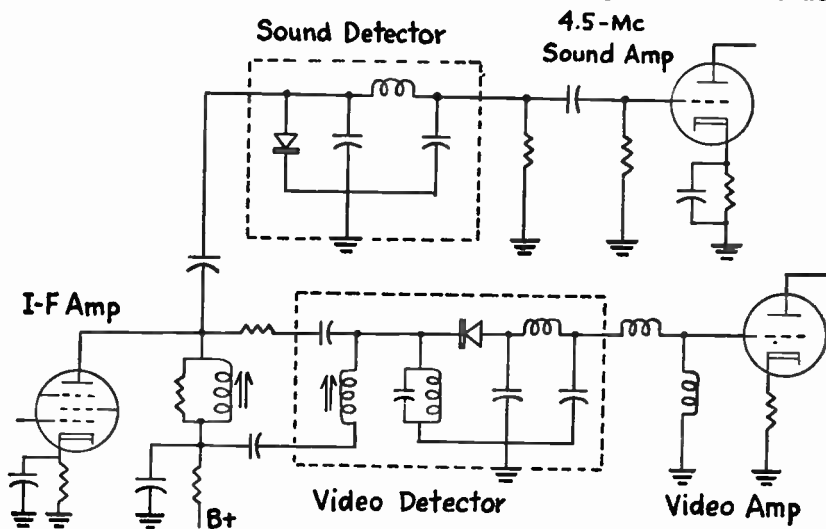

Fig. 6.—Separate detectors for video and sound in a color receiver.

detector, also a separate detector for sound. Fig. 6 is a circuit diagram. In some receivers the sound detector may supply also the chrominance amplifier instead of taking the input for this amplifier from a video amplifier. There are other combinations of detectors. Detectors in many color receivers are of the crystal diode type.

Sound Section. The sound section of a color receiver is no different than in a black-and-white set. The intercarrier sound system is almost universally used in color receivers.

Video Amplifier. Video amplifiers for color are similar to those for black-and-white. Usually there will be a 4.5-mc trap to pre-

vent interference between this intercarrier beat frequency and the color-signal carrier frequency of 3.58 mc. Interference would cause beat lines on pictures.

Sync Section. Sync sections suitable for black-and-white are satisfactory also for color receivers, and are of similar designs.

Horizontal Afc System. The same types of automatic frequency control for horizontal sweep oscillators are used for color and for black-and-white.

Sweep Oscillators. Horizontal and vertical sweep oscillators are of the same general types in both kinds of receivers.

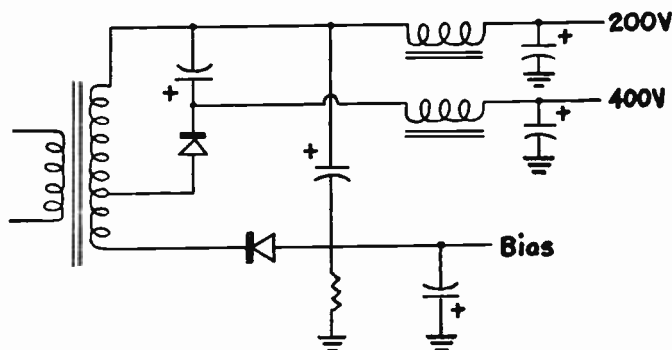

Fig. 7.—A low-voltage B-power supply such as used in color receivers.

Deflection Systems. A single deflecting yoke containing pairs of horizontal and vertical coils is on the neck of the color picture tube near the flare. The deflecting coils take more power than for a single-gun black-and-white picture tube, since three electron beams must be simultaneously deflected against higher anode voltages than employed for most black-and-white receivers. Damper tubes and circuits are generally like those in black-and-white receivers. Vertical retrace blanking circuits are similar in both kinds of receivers.

Ion Trap. Color picture tubes have aluminized or metal-backed viewing screens whose phosphors are protected from effects of ion bombardment by the metal coating. Therefore, ion traps are not needed and are not used in color sets.

Low-voltage D-c Power Supply. Low-voltage power supplies or B-voltage supplies are generally similar to those in some black-

and-white television receivers and in large radio sound receivers. It is common practice to employ selenium rectifiers, with voltage doubler circuits and step-up transformers feeding one or more rectifiers. Circuits for such a power supply are shown by Fig. 7.

Service and Operating Controls.—Since tuners are of the same types for color and for black-and-white, fine tuning controls are similar. Fine tuning for color requires more careful adjustment than for black-and-white if correct coloring is to appear in pictures.

Contrast controls for color receivers commonly are adjustable cathode biases or sometimes adjustable plate voltages on video amplifiers or luminance amplifiers of Fig. 5. The luminance amplifier is essentially another video amplifier. It is necessary that signals going to the picture tube by way of the luminance amplifier and those going by way of the chrominance amplifier be equally and simultaneously strengthened or weakened by the contrast control.

A single contrast control on a video amplifier whose output goes to both the luminance and the chrominance sections will affect both sections equally. However, were contrast to be adjusted by one control on a luminance amplifier and by a separate control on a chrominance amplifier, the two controls would be ganged to operate together from a single panel knob.

Brightness controls must affect all three electron beams equally in a three-gun picture tube. When the three cathodes are tied together, as in Fig. 5, the brightness control may be a single adjustable resistor applying a variable positive voltage to the cathodes.

The same general types of horizontal and vertical hold control circuits found in black-and-white sets are used in color receivers. This is true also of horizontal drive controls, and of size controls for picture width and height.

Controls for horizontal and vertical centering are of types which send an adjustable direct current through the coils of the deflecting yoke. This current adds itself to the sawtooth deflecting currents, in one polarity or the other, to shift average deflection of the center of deflection to one side or vertically as required.

Horizontal and vertical linearity controls in color receivers are of the same types as may be found in black-and-white receivers. Vertical linearity commonly is adjusted by variable cathode bias on the vertical sweep amplifier. The horizontal linearity control often is an adjustable inductor connected across part of the turns of the horizontal output transformer.

Producing Black, White, and Colors.—Now we may return to the three-gun picture tube and to how it produces any and all colors as well as the appearance of black-and-white.

Production of black areas or black lines is simple. None of the phosphors are excited, by reducing the intensities of all three electron beams to zero while they pass points which are to appear black on the viewing screen.

White requires that all three kinds of phosphors be excited to certain relative light emissions. One method of obtaining such relative emissions during service adjustments is as follows:

The receiver is tuned to a black-and-white or monochrome signal, with which only the equivalent of a brightness or luminance signal is received and applied to picture tube cathodes. Then positive voltages on the screen grids of the three guns are adjusted, and negative biases on the grids of color amplifiers are adjusted, until all coloring disappears and only white remains. Obviously, we then have the proportions of blue, green, and red lights which blend together in our eyes to cause the sensation of white light.

If intensities of all three electron beams are reduced, while maintaining the same *relative* intensities, the white will change to light gray. Further reduction without altering proportions of the three primary colors will produce darker grays. Finally, with intensities of all three beams at zero, we have black on the viewing screen.

The luminance signal, which produces white, gray, or black at the receiver picture tube, is originally formed at the transmitter by taking certain percentages or fractions of the total outputs from the three camera tubes. When the camera is viewing white or gray these fractions of the color signal outputs will cause the appearance of white or gray at the picture tube in the receiver—provided picture tube screen grid voltages and control grid biases are correctly adjusted.

When colors are to appear on the picture tube it is necessary that relative light emissions of the three kinds of phosphors be altered. Since the luminance or brightness signal will continue to act on the cathodes, alterations for color must result from changes of voltages at control grids in the three electron guns.

Control grid voltages are color-signal voltages which come through the chrominance section and associated sections. Each color signal voltage which arrives at its respective electron gun may be either negative or positive, in varying strengths, and will make the control grid either more or less negative than required for production of white or gray.

Grid Voltages and Color Characteristics.—Supposing we wish to produce a variety of red shades on the viewing screen; such as rose, pink, carmine, vermillion, and also pure red, which might be described as ruby red. Before applying any color signals to control grids we have on the cathodes a luminance signal whose relative effects on the three cathodes may be shown as at the top of Fig. 8.

Voltages represented in Fig. 8 are the fractions of camera output voltages which combine to form the luminance or brightness signal. The cathode voltages are shown as negative because the luminance signal will have been inverted in the luminance amplifier section of the receiver.

4—coyne school 4677 M1

A negative voltage at a cathode has the same effect on beam current or intensity as has an equal positive voltage at the control grid in the same gun. This is the effect with which we are familiar in ordinary triodes or pentodes. Making a cathode more positive has the same effect on plate current as making the control grid more negative. Making a cathode less positive has the same effect as making the grid less negative. Accordingly, the effects of negative luminance voltages at the cathodes in the color picture tube are equivalent to equal positive voltages at the control grids, as shown at the bottom of Fig. 8.

To produce a primary red color on the viewing screen of the picture tube it is necessary to reduce blue and green emissions to zero, and to increase red emission to maximum, denoted as 100% or as 1.00. Applying to the three control grids the color signal voltages represented by solid lines at the top of Fig. 9 will do this.

At the top of Fig. 9 the luminance voltages from the bottom of

Fig. 8 are shown by broken lines. For blue there is now a combination of -0.11 and $+0.11$, which cancel to leave zero beam current from the blue gun, and no excitation of blue phosphor dots. For green we have cancellation of -0.49 and $+0.49$, leaving no green electron beam and no excitation of green phosphor dots. But for red we have $+0.30$ and $+0.70$, which add together for full intensity of the red beam, and full excitation of red phosphor dots. The overall result is illustrated at the bottom of Fig. 9.

At the top of Fig. 10 the negative green signal on the green grid is not sufficiently negative to cancel all of the positive effect of the luminance signal. Consequently, as shown below, we have a little green mixed with the red; the green phosphor dots are slightly excited. The apparent color changes to what might be called cherry red.

In Fig. 11 the red and green remain as in Fig. 10. But the negative color signal on the blue grid does not cancel all of the effect of cathode voltage in this gun. Then, as shown below, we

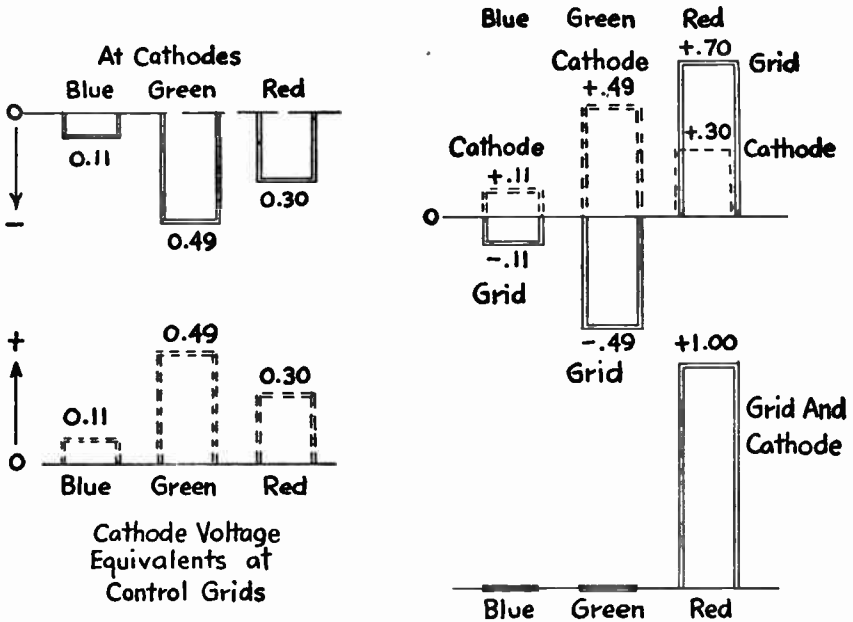

Fig. 8.—Voltage at the cathodes has the same effect as voltage of inverted polarity at the grids.

Fig. 9.—Blue and green cathode and grid voltages cancel, while red voltages add together.

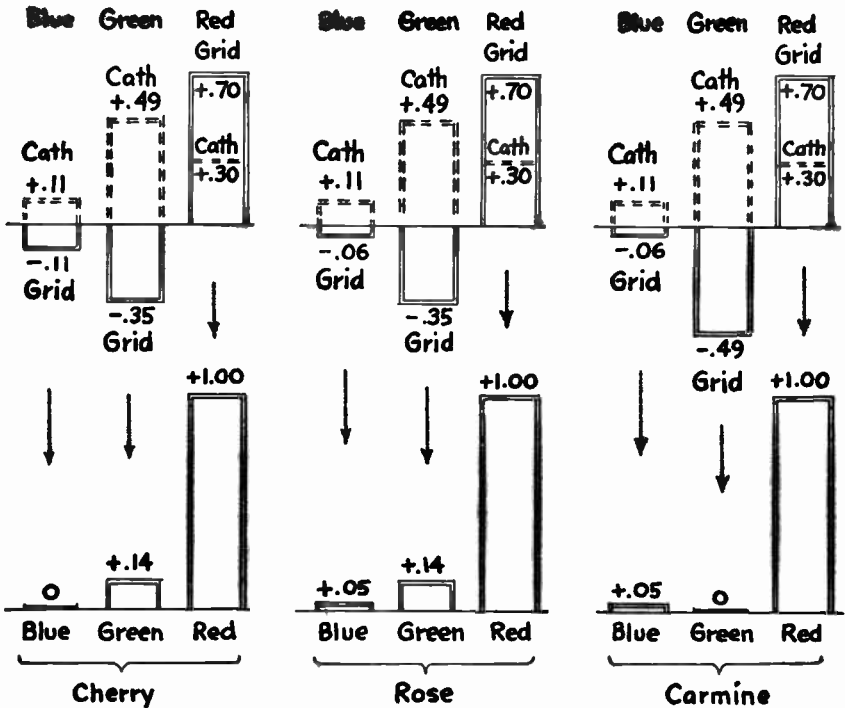

Fig. 10.—(left) Green added to red produces cherry red effects. Fig. 11 (center) Adding blue to green and red produces a rose color. Fig. 12 (right) Adding a little blue to red produces the color called carmine.

have a large amount of red mixed with a little green and a little blue. The apparent color would be called rose, which is a variety of red.

In Fig. 12 the red and blue remain as in Fig. 11. But now the negative color signal on the green grid has been strengthened to cancel all the green effect from the green cathode. The apparent color would be carmine, which is a slight variation from our fundamental red.

In Figs. 8 to 12 the fundamental or predominant color always is red. In all these variations the hue is red. Hue refers to the predominant color. Were the principal or strongest color to be blue, the hue would be blue. With mostly green the hue would be green. With approximately equal parts of red and green the hue would be yellow, or with green and blue the hue would be cyan,

or with blue and red it would be magenta. On all color receivers there is an adjustable control for obtaining proper hues in reproduced pictures.

Now look back at Fig. 10, where adding a little green to the predominant red produced cherry red coloring. Control grid voltages or color signal voltages for cherry red are shown again at 1 in Fig. 13. At 2 all three grid voltages have been reduced at about 70% of their former value, but *relative* proportions of these grid voltages are not altered.

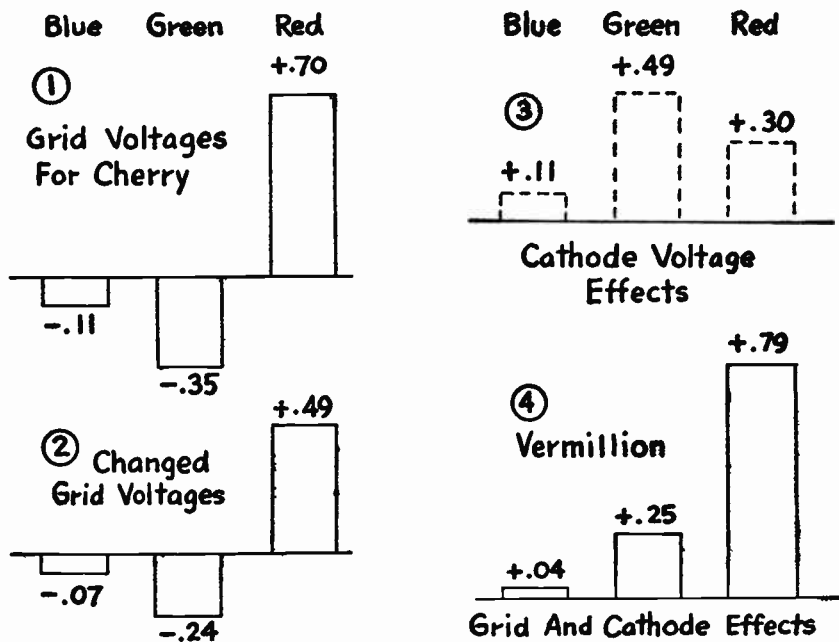

Fig. 13.—Reducing all the grid voltages, which lessens the saturation, changes cherry red to vermillion.

At 3 in Fig. 13 are shown the effects at the grids of luminance or brightness signal voltage on the cathodes. These are the same as cathode voltages in Fig. 10. At 4 of Fig. 13 are the combined effects of voltages on grids and cathodes. Apparent color has changed from cherry red to vermillion.

Let's see what has happened in Fig. 13. Effective luminance signal voltages have not been changed. The luminance signal, by itself, produces white. Therefore the amount of white has not

been changed. But all the color voltages, at the grids, have been reduced together. This means that we have less color mixed with the white.

Mixing of colors into white that corresponds to the luminance signal is described as *saturation*. If only a little color is mixed into white the saturation is said to be low. Should there be something like half color and half white the saturation is medium. When there is all color and no white, as at the bottom of Fig. 9, saturation is very high or is maximum.

The difference between cherry red of Fig. 10 and vermillion of Fig. 13 is a matter of saturation. There is less saturation in Fig. 13, which means simply that there is less color and that more white remains, so far as proportions are concerned. On every color receiver is an adjustable control for saturation. This is one of the operating controls on a color receiver for which there is no counterpart on a black-and-white receiver. The other control found only on color receivers is the hue control. The saturation control may be called the chroma control.

Were we to reduce all three color-signal voltages in Fig. 11, leaving proportionately more white and less saturation, the apparent color would change from rose to pink. Less saturation or less color in Fig. 12 would change the apparent color from carmine to cerise.

Changing the saturation does not alter the predominant color or hue, it changes only the amount of that hue which is mixed with white. Also, a change of hue need not alter the saturation, we may have equal degrees of saturation with any hue.

As the three electron beams traverse the phosphor dots the beams must continually vary in intensity to produce changes of shading and of coloring in various areas of a picture. To produce effects of lights and shadows, beam intensities are changed by variations of luminance signal voltage. These variations affect all three beams alike, because the luminance signal is applied simultaneously to all three cathodes.

Changes of color between picture areas result from separately varying the individual intensities of the three electron beams. Variations of separate intensities result from changes of color signal voltages acting on the three control grids. During reproduction of multi-colored pictures the grid voltages continually

vary in strength and in polarity, as you will realize from examining Figs. 9 through 13.

Interleaving.—At the grid-cathode circuits of the color picture tube we need four signal voltages, one for brightness or luminance, and one each for blue, green, and red colors. Were four separate signals to have the form of four modulated carriers in space and in the i-f amplifier section of the receiver, each signal would require its own range of video frequencies.

To handle everything from sync pulses to finest detail in pictures, the luminance signal alone would require a range from about 50 cycles to four megacycles per second. Color signals would require additional frequency ranges. Although each color might be handled in range of somewhat less than one megacycle, even so, all four signals wouldn't fit into the standard television channel, which can accommodate a total of only about four megacycles of video frequencies.

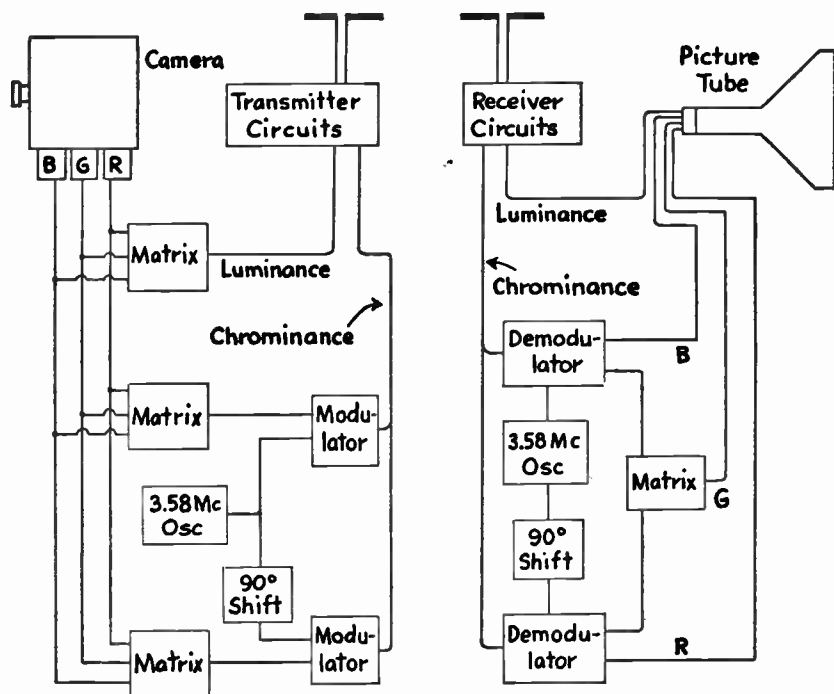

Fig. 14.—Luminance and chrominance signals formed at the transmitter are separated into their brightness and color components at the receiver.

The seemingly insurmountable problem is solved as shown, in part, by the simplified block diagram of Fig. 14. Color signal voltages from the camera at the transmitter are applied to one matrix section from which issues the luminance or brightness signal. A matrix is essentially a combination of resistors in which definite fractions of voltages are combined.

The blue, green, and red camera voltages are fed also to two other matrixes which form two color signals. These combination color signals go to two modulators where they become modulation on two 3.58-mc voltages. The 3.58-mc voltage to one modulator is 90° out of phase with that to the other modulator. Now we have two modulated color signals differing in phase by 90 electrical degrees.

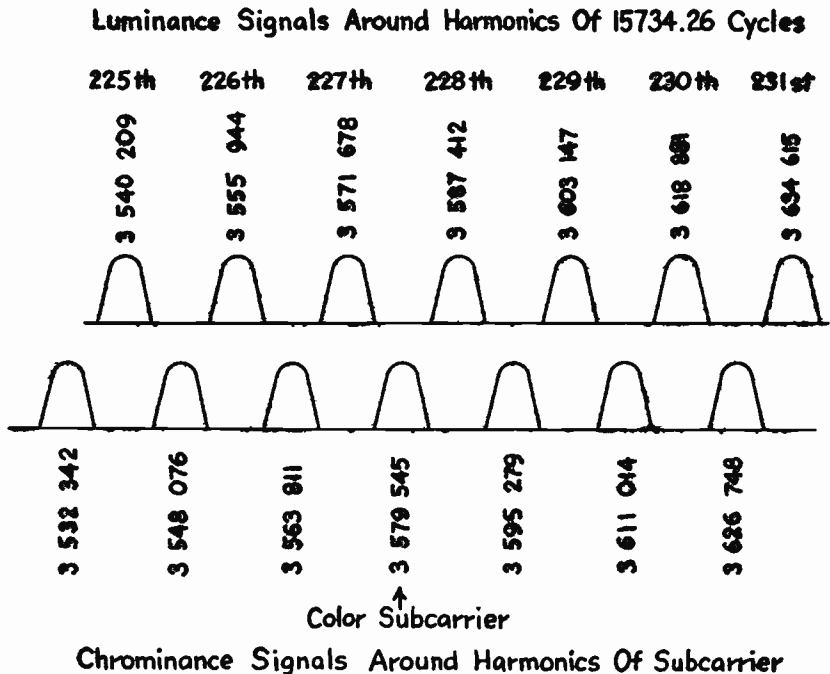

Fig. 15.—Luminance and chrominance signals may be transmitted in the same range of video frequencies because the two signals interleave.

Two voltages that are out of phase will combine to form a single voltage whose amplitude and phase vary with changes of amplitude and phase in the two original voltages. This single

voltage which varies in amplitude and phase is the chrominance signal. Later it will be changed back into the original components.

The single chrominance signal and the luminance signal may be transmitted and received within the same range of video frequencies, because their modulations on a carrier combine in a way called interleaving, illustrated by Fig. 15. Although video frequencies for the luminance signal extend all through the band up to four megacycles, these frequencies are not continuous. It is found that signal amplitudes are maximum only at harmonics of the horizontal line frequency, and practically disappear for about half the intervening ranges. Maximum amplitudes of the chrominance signal are at harmonics of the 3.58-mc color subcarrier, and disappear between these harmonics.

Line-frequency and subcarrier harmonics alternate, with each kind just half way between those of the other kind. This is brought about by suitable choice of frequencies. Horizontal line frequency for color television is 15734.26 cycles per second instead of 15750 cycles as for black-and-white signals. Color subcarrier frequency is 3,579,545 cycles, or 3.579545 megacycles per second. This usually is specified as the approximate value of 3.58 mc.

Chrominance Signal.—The chrominance signal may be formed at the transmitter as follows. Part of the luminance or Y-signal is inverted in polarity to make it negative. Then, using the letters *B*, *G*, and *R* for blue, green, and red color voltages, we have,

$$\begin{array}{r} -Y = \\ -0.11 B \quad -0.59 G \quad -0.30 R \end{array}$$

Assume that a red picture area is being scanned, causing an output of +1.00 *R* or maximum red. The $-Y$ signal is added to this red signal thus,

$$\begin{array}{r} \text{Red} = \\ -Y = \\ \text{R-Y} = \\ +1.00 R \\ -0.11 B \quad -0.59 G \quad -0.30 R \\ -0.11 B \quad -0.59 G \quad +0.70 R \end{array}$$

The resulting R-Y signal is a color-difference signal called red-minus-Y, which means red-minus-luminance, or minus brightness.

A blue-minus-Y signal is formed by adding the -Y signal to blue, like this

	Blue =
	-Y =
	B-Y =
+1.00 B	
-0.11 B	-0.59 G
+0.89 B	-0.59 G
	-0.30 R
	-0.30 R

It would be possible to form a green-minus-Y or G-Y signal, but such a signal is not needed. It is not needed because green may be recovered later on from the R-Y and B-Y signals, since both contain green as a component. Amplitudes of the R-Y and B-Y signals will be varied by changes of color voltages from the camera system.

The 3.58-mc voltage mentioned earlier originates in a master oscillator at the transmitter. This voltage goes to one modulator where it is modulated by the R-Y signal. In another lead from the master oscillator the 3.58-mc voltage is delayed 90° in phase, then fed to the other modulator where it is amplitude modulated by the B-Y signal.

Amplitude of the 3.58-mc voltage which is modulated by the R-Y signal might be as at 1 of Fig. 16, while amplitude of the 3.58-mc voltage modulated by the B-Y signal might be only half as great, as represented at 2. Note that voltage at 2 lags 90° behind that at 1.

The two 3.58-mc voltages combine to form the chrominance signal at 3. Frequency of this chrominance signal is 3.58 mc, but its amplitude and phase differ from amplitude and phase of either of the original 3.58-mc voltages. Amplitude of the chrominance signal voltage depends on amplitudes of the two component 3.58-mc voltages, and these amplitudes, in turn, depend on strengths of the R-Y and B-Y color-difference voltages. Strengths of the color-difference voltages depend on saturations of colors being televised. Therefore, amplitude of the chrominance signal depends on, and varies with, saturations in televised scenes.

Phase of the chrominance signal is in between phases of its component voltages. Chrominance phase in Fig. 16 lags about 27° behind that of the voltage at 1, and leads the voltage at 2

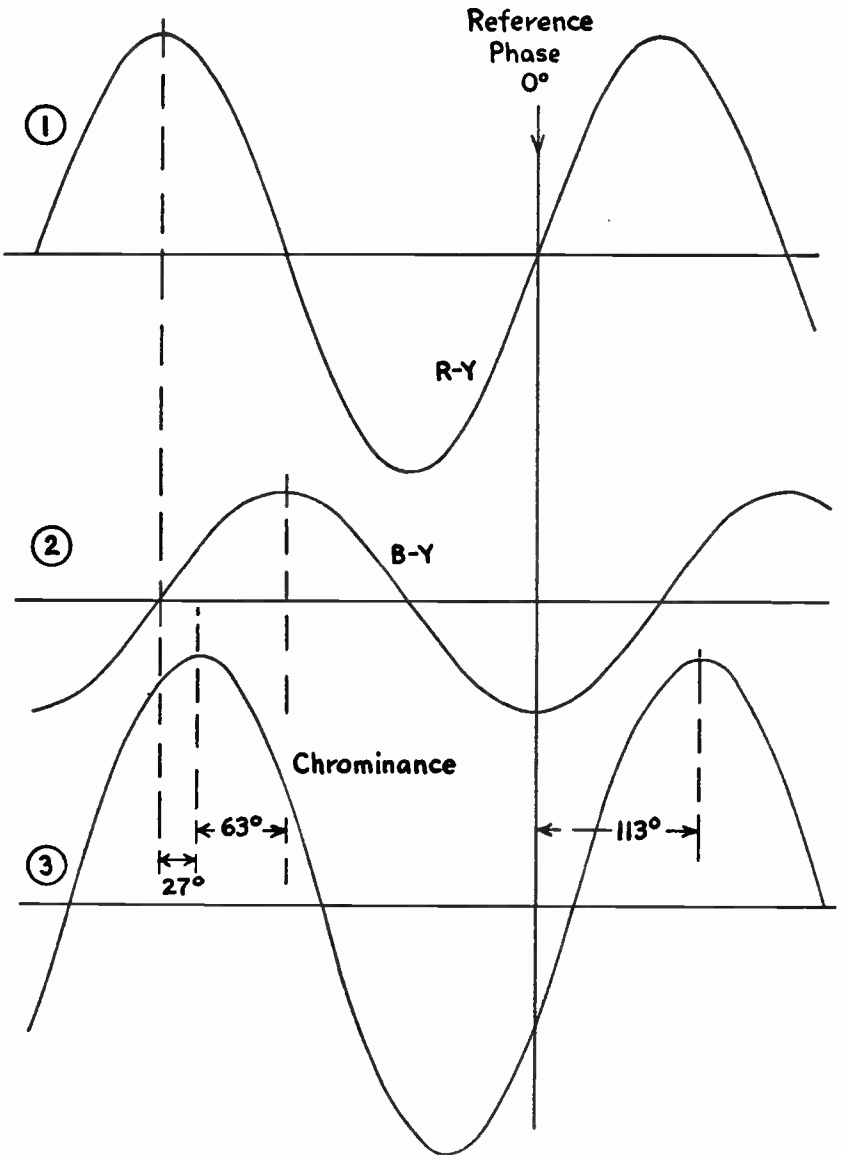

Fig. 16.—A chrominance signal is formed by combining the two 3.58-mc voltages which are modulated by the color-difference signals.

by about 63° . Chrominance phase is relatively close to that of the 3.58-mc voltage modulated by R-Y, in which there is a great deal of red, and is farther from phase of the voltage modulated by B-Y, in which there is a great deal of blue. Accordingly, this particular phase of the chrominance signal means red tinged with a fair amount of blue, or it indicates a kind of purple coloring at the point being televised in a scene.

Phase of the chrominance signal always represents hue, or predominant color. Changes of hue will shift the phase of the chrominance signal. Changes of saturation will change the amplitude of the chrominance signal.

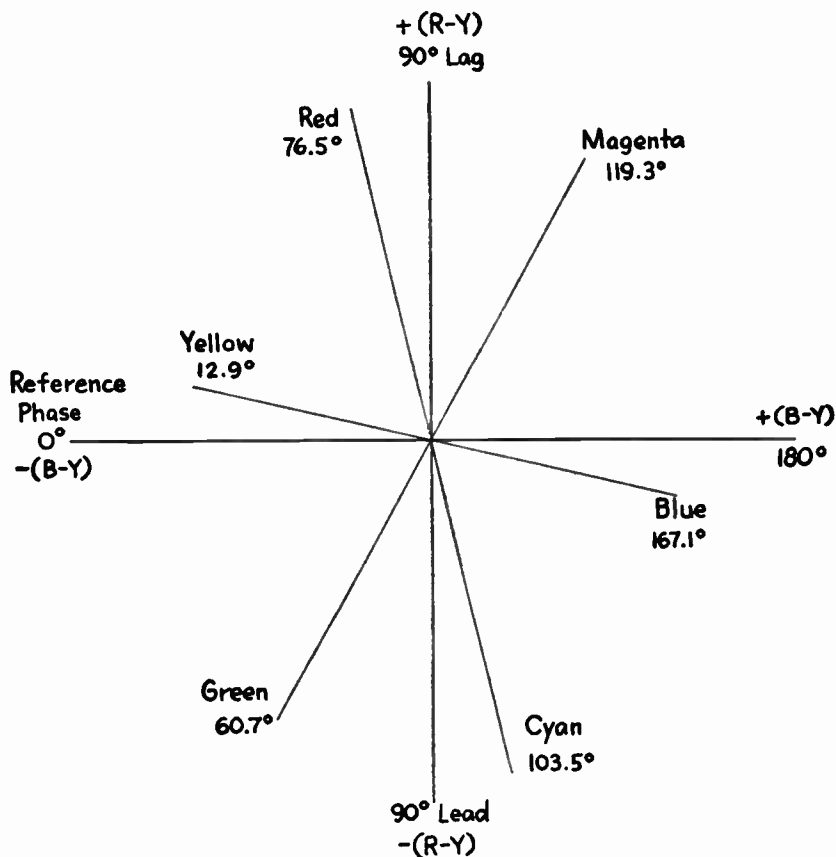

Fig. 17.—Phase relations between the reference phase, the color-difference signals, and the primary and secondary color signals.

Phase of master oscillator voltage, which is the reference phase for all chrominance signals, is considered as of zero phase angle. As indicated in Fig. 16, this zero reference phase coincides with maximum negative amplitude of the 3.58-mc voltage modulated by B-Y.

Fig. 17 shows chrominance signal phase angles with respect to the reference phase for all three primary colors and for their complementary colors. A complementary color is one which, combined in suitable proportions with another color, causes the sensation of white light. Complementary colors sometimes are called secondary colors, to distinguish them from the primaries. The complementary of blue is yellow, of green it is a purplish color called magenta, and of red it is a bluish-green called cyan.

Demodulation.—At the receiver we have the chrominance signal whose frequency is 3.58 mc, whose phase represents hue, and whose amplitude represents saturation. From this signal we shall recover the R-Y and B-Y color-difference voltages, then combine or matrix fractions of these voltages to obtain the G-Y voltage. The final step will be to combine the —Y voltage with each of the three color-difference voltages to leave B, G, and R (blue, green, and red) color voltages acting between grids and cathodes of electron guns in the color picture tube.

R-Y and B-Y voltages are recovered by using two demodulators, each of which may consist of a twin-diode, of a single triode, or of a single pentode tube. Typical demodulator circuits are shown for twin diodes in Fig. 18, for triodes in Fig. 19, and for pentodes in Fig. 20. No matter what kind of tubes are used, the chrominance signal is applied to both demodulators. To one demodulator is applied also a 3.58-mc voltage which is in phase with the reference, and to the other demodulator is applied a 3.58-mc voltage lagging by 90° .

By processes essentially the reverse of those employed for modulation, the demodulators produce output voltages whose polarities change with shifts of phase in the applied chrominance signal. That is, demodulator output polarity varies with changes of hue. Amplitude of demodulator output voltage is proportional to amplitude of the chrominance signal, since the 3.58-mc voltages to the demodulators remain of constant amplitudes.

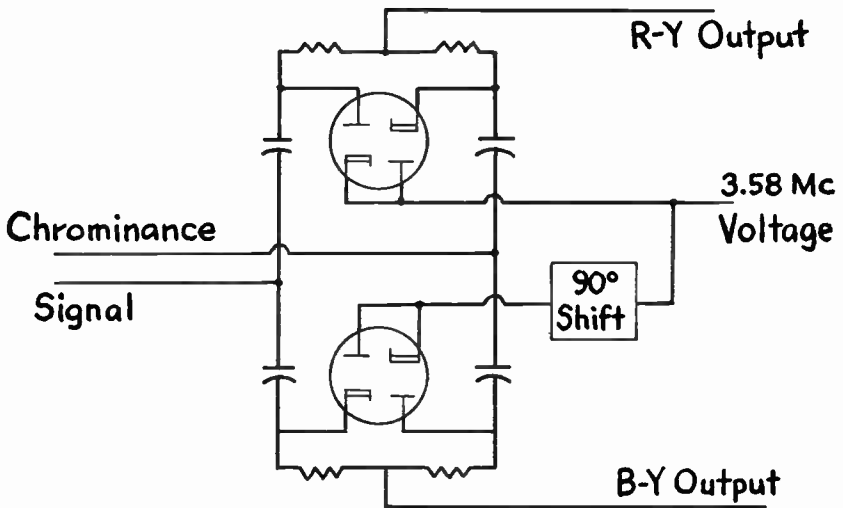

Fig. 18.—Color demodulators consisting of two twin-diode tubes.

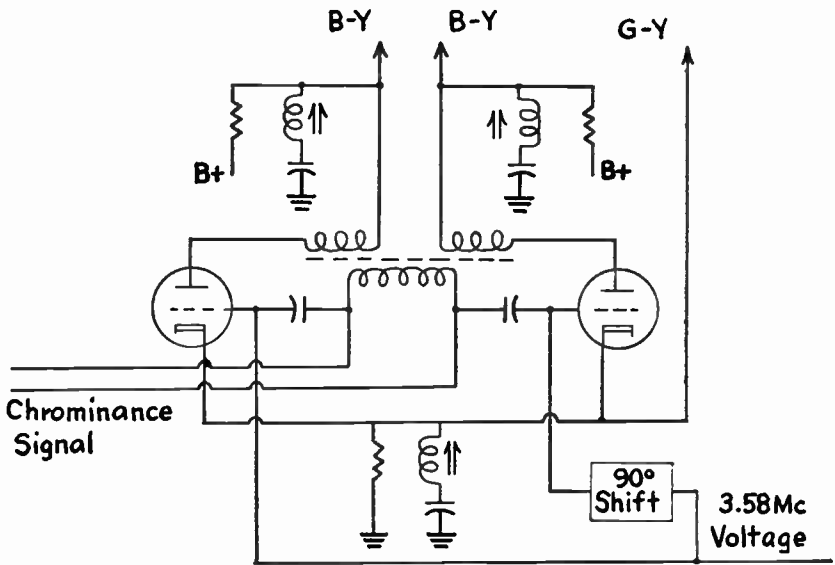

Fig. 19.—Triode tubes as color demodulators. The G-Y signal is formed at the cathodes.

One demodulator recovers the R-Y color-difference voltage, while the other recovers the B-Y voltage. The R-Y voltage is applied to the control grid of the red gun in the color picture tube, while the B-Y voltage goes to the control grid of the blue gun. Since the luminance or Y-signal is applied to cathodes of all three guns there is effectively a red color voltage at the red gun and a blue color voltage at the blue gun.

This method of producing color voltage is illustrated, for red, by Fig. 9. Consider that the R-Y voltage is as shown by solid lines. The $-Y$ voltage, effectively inverted to $+Y$ at the grids, is as shown by broken lines. R-Y and $-Y$ combine to leave only red. You will find that combining B-Y values with $-Y$ values, again inverted to $+Y$ at grids, leaves only blue.

In some color receivers the R-Y and B-Y signals combine at the cathodes of the demodulators to produce G-Y for picture tube control grids. Otherwise the G-Y signal may be secured by matrixing the outputs of the R-Y and B-Y demodulators in the following manner.

First consider the R-Y and B-Y voltages, which have been shown earlier as consisting of these component color voltages.

$$\begin{array}{rcl} \text{R-Y} & = & -0.11 \text{ B} \quad -0.59 \text{ G} \quad +0.70 \text{ R} \\ \text{B-Y} & = & +0.89 \text{ B} \quad -0.59 \text{ G} \quad -0.30 \text{ R} \end{array}$$

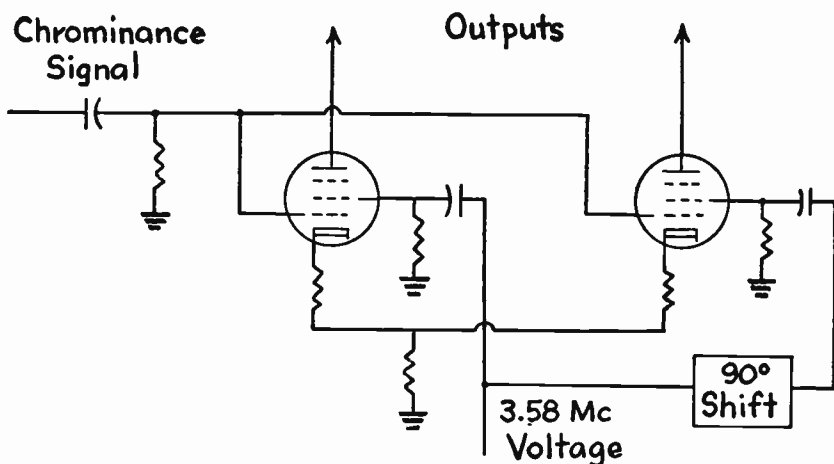

Fig. 20.—Two pentodes may be used as color demodulators.

Now we may take 51% or 0.51 times the R-Y voltage and 19% or 0.19 times the B-Y voltage, invert their polarities, and combine them. In the combination keep in mind that two positive voltages add for positive, two negatives add for negative, and that positive and negative subtract to leave the greater voltage. Approximate fractional inverted voltages and the results of their combinations are as follows:

$$\begin{array}{rcl}
 -0.51 \times R-Y & = & +0.057 B \quad +0.298 G \quad -0.357 R \\
 -0.19 \times B-Y & = & -0.167 B \quad +0.112 G \quad +0.057 R \\
 G-Y & = & -0.11 B \quad +0.41 G \quad -0.30 R
 \end{array}$$

When this G-Y color-difference voltage is applied to the green grid of the picture tube it combines with the -Y signal, effectively +Y at the grid, as follows.

$$\begin{array}{rcl}
 G-Y & = & -0.11 B \quad +0.41 G \quad -0.30 R \\
 +Y & = & +0.11 B \quad +0.59 G \quad +0.30 R \\
 & & O B \quad +1.00 G \quad O R
 \end{array}$$

Here we have a full strength green color signal, with no blue and no red.

Color Amplifiers.—In some receivers there are amplifier tubes between the demodulator outputs and the electron gun connections of the picture tube. There may be one amplifier for the R-Y signal, a second for the G-Y signal, and a third for the B-Y signal. In other designs the three color signal voltages, blue, green, and red, are formed in a system of matrix resistors, then put through three amplifiers before going to the picture tube.

As a general rule there will be gain controls for the blue and green amplifiers or for B-Y and G-Y amplifiers, but none for the red or the R-Y amplifier. These adjustments, which may be called background controls, are used during servicing to allow such relative outputs from the amplifiers as to correctly balance the colors for reproduction of white or gray.

Since color amplifiers handle frequencies in the higher video range there may be peakers, partially bypassed cathode resistors, and other circuit features for maintaining good gain at high video frequencies. There may also be d-c restoration circuits between color amplifier outputs and picture tube inputs.

Chrominance Amplifier.—Now we may go to the output of a video or sound detector and follow the path of the chrominance signal from there to the demodulators. This path includes the chrominance amplifier section of the receiver, of which an ex-

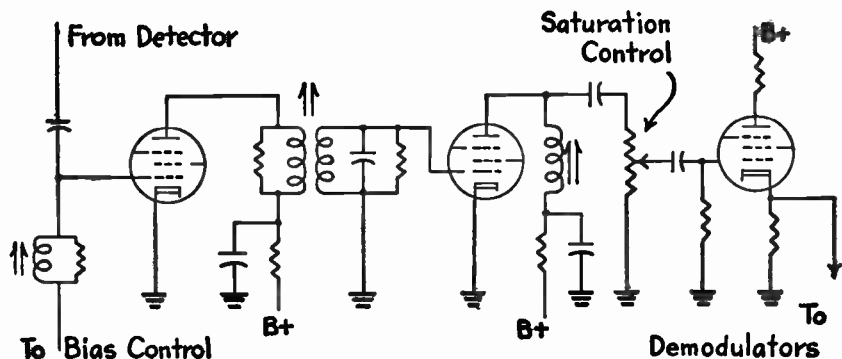

Fig. 21.—A chrominance amplifier section of a color receiver.

ample is shown by Fig. 21. Input to the chrominance amplifier is the composite color signal, which appears first at the output of a detector which demodulates the i-f signals. Although the composite signal commonly is taken from a detector output, it may be taken otherwise from a video amplifier plate circuit or from a contrast control on a video amplifier.

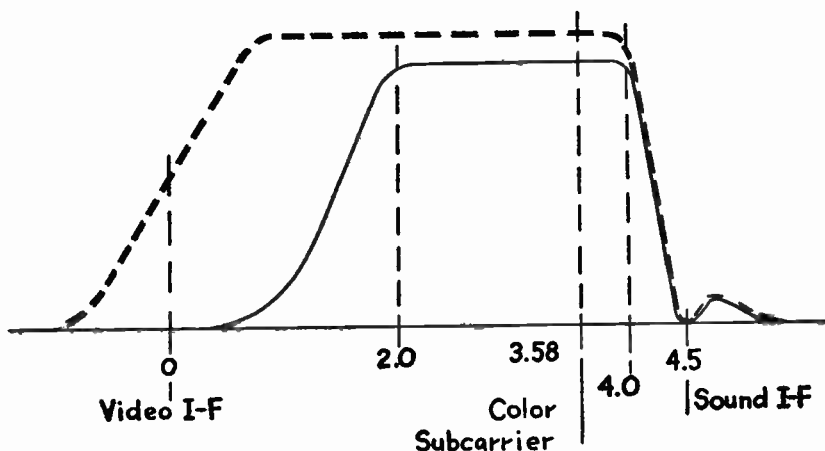

Fig. 22.—Frequency response of a video or luminance amplifier (broken-line) and of a chrominance amplifier (full-line).

The most notable feature of the chrominance amplifier is that its couplings are designed to pass only the limited range of video frequencies which include the chrominance signal. This frequency range is shown by the full-line curve of Fig. 22, where the range for the luminance signal is shown by the broken-line curve. The

chrominance amplifier may be called a bandpass amplifier because it passes only a limited band of frequencies.

As a general rule there will be at least one 4.5-mc trap in the chrominance amplifier section. This is especially true when chrominance input is from the same detector that handles sound signals. Some chrominance amplifiers have automatic gain control.

Color Oscillator Section.—Each demodulator must be supplied with a 3.58-mc voltage, in addition to the chrominance signal. One of these 3.58-mc voltages must be shifted 90° with respect to the other, and phase of both voltages must be held in precise relation to phase of master oscillator voltage sent from the transmitter.

As you may see in Fig. 5, the 3.58-mc voltages for the demodulators come from a color oscillator in the receiver. There is a lead from this oscillator directly to one demodulator, and another lead goes through a 90° phase shift circuit to the other demodulator.

Color oscillator frequency and phase are maintained in correct relation to frequency and phase of the master oscillator of the transmitter by means of an automatic phase control marked *APC*. This control operates quite similarly to an automatic frequency control used on horizontal sweep oscillators in black-and-white receivers.

In a black-and-white receiver the afc system for a horizontal oscillator is fed one voltage from the oscillator output and another voltage derived from horizontal sync pulses which are to control oscillator frequency. The afc system produces a correction voltage which is applied to the sweep oscillator for slowing it down when its frequency tends to go too high, and for speeding the rate of oscillator when frequency tends to drop.

The automatic phase control of the color receiver is fed with one voltage from the color oscillator output and with another from the burst amplifier. The burst amplifier delivers a 3.58-mc voltage whose phase is tied to that of the master oscillator at the transmitter by a burst signal transmitted along with all the other signals.

This burst signal combines with the feedback from the color oscillator in the automatic phase control circuits to produce a correction voltage that is applied to the color oscillator to keep its phase in correct relation to phase of master oscillator voltage. Were this not done, hues in reproduced pictures would be different than in televised images.

At first thought it might seem impossible to find any place in the composite color signal for the 3.58-mc burst voltage, but there is a place on the back porch of the pedestal formed during horizontal blanking. The burst consists of not less than eight cycles occupying the position shown in Fig. 23.

There is a burst on the back porch following every horizontal sync pulse. No bursts follow equalizing pulses or serrated vertical sync pulses. Bursts are transmitted only with color signals. There are no bursts when a color transmitter is sending monochrome signals, and, of course, no bursts are sent from a black-and-white transmitter at any time.

Transmitted and received 3.58-mc voltages are called bursts because they occur only intermittently, only at horizontal line intervals. The bursts do not affect horizontal synchronization, because horizontal retrace begins before each burst occurs. Bursts do not affect pictures, because the bursts occur during horizontal blanking.

Gating the Bursts.—Burst signals come to the chrominance amplifier along with all other parts of the composite color signal. Because burst frequency of 3.58 mc is within the pass band of the chrominance amplifier the bursts are amplified. Then they are applied to the burst amplifier.

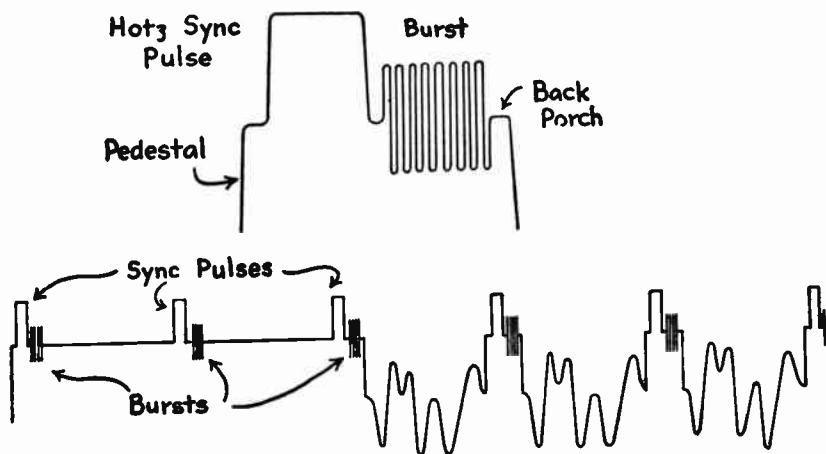

Fig. 23.—The burst voltage and its relation to the horizontal blanking intervals.

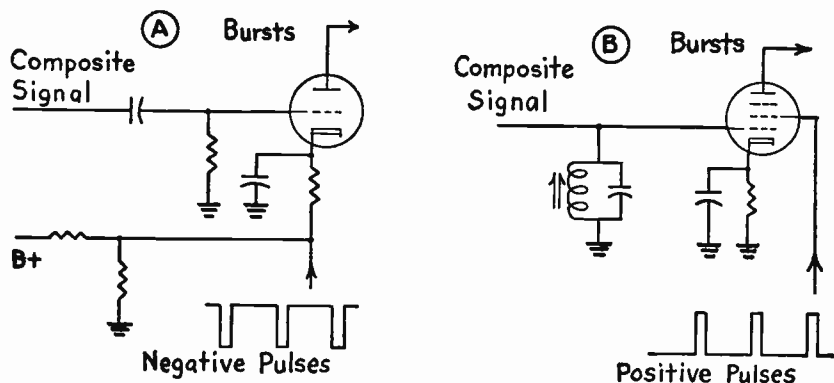

Fig. 24.—Burst amplifiers are gated by voltage pulses occurring just after horizontal sync pulses.

Since it is desirable that no portions of the composite signal other than bursts go through to the automatic phase control, the burst amplifier is gated to pass only the bursts. By gating we mean that the burst amplifier is held non-conductive except during instants in which bursts occur, and is allowed to become conductive only during bursts.

Two methods of gating are shown by Fig. 24. At A the cathode normally is held sufficiently positive for plate current cutoff; a positive cathode being equivalent to a negative grid so far as effect on plate current is concerned. The tube is made conductive only when strong negative voltage pulses are applied to the cathode. These negative pulses are derived from horizontal sweep circuits, usually from an auxiliary winding on the horizontal output transformer. Since burst pulses are transmitted and occur during flyback periods, only the bursts pass through the amplifier to the automatic phase control system.

At B of Fig. 24 the only voltage applied to the screen grid of a pentode amplifier is in the form of positive pulses obtained from the horizontal sweep section of the receiver. Except during these pulses the screen grid voltage is zero, and the tube is non-conductive. Conduction occurs only while the screen grid is made positive by the pulses, and only the burst signals are passed.

Voltage pulses for gating the burst amplifier are brought from the horizontal sweep circuits through some combination of capacitors and resistors which delay the pulses about four or five

While oscillator output voltage is in phase with burst voltage the phase detector develops no correction voltage. But when the two voltages to the detector are out of phase a d-c correction voltage appears at the electrical center of the resistors, and is taken from there through a noise filter to the grid of a reactance tube. Whether correction voltage is positive or negative depends on whether oscillator voltage leads or lags the burst voltage. Strength of correction voltage is proportional to the phase difference.

The grid circuit of the color oscillator consists of three parts in parallel with one another; (1) the reactance tube, (2) a parallel resonant circuit consisting of inductor L_g and a capacitor, and (3) a quartz crystal that is resonant at 3.58 mc.

Connected to the color oscillator plate is another parallel resonant circuit consisting of inductor L_p and a capacitor. The oscillator tube, its tuned plate circuit, and the crystal, considered by themselves, form a common type of crystal controlled oscillator. But in parallel with the grid circuit containing the crystal are the reactance tube and the parallel resonant circuit at L_g .

In Fig. 25 the phase shift required for alternating grid voltage on the reactance tube is obtained by connecting a small capacitor, about two mmf, from plate to grid. This causes the tube to act as a variable reactance across the parallel resonant circuit at L_g . Resonant frequency of this circuit is varied by changes of plate current in the reactance tube. The changes of plate current are brought about by the d-c correction voltage coming from the phase detector to the reactance tube grid.

The oscillating crystal holds frequency of the color oscillator practically constant at 3.58 mc, while the reactance tube circuit corrects any slight deviations of oscillator phase from phase of burst signal voltage applied to the phase detector.

Demodulator Phase Shift.—The color oscillator system must furnish to the demodulators two 3.58-mc voltages, one lagging the other by 90° . There are two fairly common methods for obtaining such a phase shift. One employs a series resonant circuit consisting of an inductor and a capacitor. The other uses a transformer whose primary and secondary are tuned to the same frequency, which here will be 3.58 mc.

Phase shift principles are illustrated by Fig. 26. In diagram 1 the lead to one demodulator carries 3.58-mc voltage which is in

phase with color oscillator output voltage. Connected to the output are an inductor L and capacitor C tuned to be series resonant at 3.58 mc. Oscillator voltage is applied across this combination. At resonance in a series resonant circuit, voltage across the capacitor lags the applied voltage by 90° . This lagging voltage is taken to the second demodulator.

Voltage across the inductor of a low-resistance series resonant circuit, at resonance, leads the applied voltage by close to 90° . Such a leading voltage may be applied to one of the demodulators, as at 2, by reversing the order of capacitor and inductor between the high side of the series resonant circuit and ground.

When a transformer connected as in diagram 3 has its primary and secondary tuned to the same frequency, which here would be 3.58 mc, the secondary voltage is 90° out of phase with primary voltage. One demodulator is fed from the primary and the other from the secondary. Whether secondary voltage leads or lags primary voltage depends on relative directions of the two windings, and at which end of the secondary the phase relations are considered. Either leading or lagging voltage may be taken from the secondary.

Hue Control.—It is evident from the color phase chart of Fig. 17 that slight changes in phase of the chrominance signal with respect to the reference phase will cause colors or hues in reproduced pictures to become markedly different from those in the televised scene. Due to various causes there may be changes of chrominance phase almost anywhere between detectors or video amplifiers and the color demodulators. Such changes must be compensated for by varying the phase of the 3.58-mc voltages delivered from the color oscillator system to the demodulators.

Thus it comes about that, after taking elaborate precautions to keep the color oscillator voltage correctly phased with respect to burst signals, we add a control which allows varying the phase of 3.58-mc voltages applied to the demodulators. This is the hue control, located on a front panel where it may be adjusted by the operator. The panel adjustment may be marked with such descriptive name as shading, or phasing.

It is possible to shift the phase of output voltage from the color oscillator by adjustments of capacitance or inductance at various places between the point at which burst signals are sepa-

rated from the composite color signal and the point at which there is the 90° phase shift that precedes the 3.58-mc inputs to the demodulators. In Fig. 25 the adjustable capacitor C on the input to the phase detector is a hue control.

Since the hue control varies the phase of the color oscillator, it varies simultaneously the phases of both the 3.58-mc voltages fed to the demodulators. Thus these two voltages always remain 90° out of phase with each other, as required for proper recovery of R-Y and B-Y color difference signals.

I-signal and Q-signal.—As explained earlier, changes of phase in the chrominance signal with respect to the burst signal and master oscillator voltages cause changes of reproduced hues. If hues are wrong, due to undesired change of chrominance phase, they may be corrected by varying the phase of 3.58-mc voltages which go from the color oscillator to the demodulators.

If changes of color oscillator phase will compensate for changes of chrominance phase, it follows that chrominance phase might be changed to compensate for any change of color oscillator phase. That is, were color oscillator phase to lag or lead the mas-

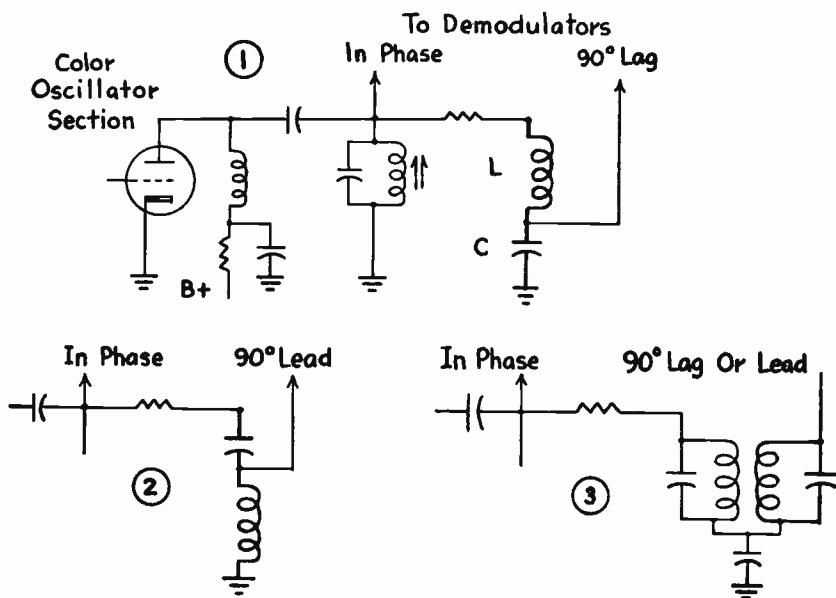

Fig. 26.—Ninety-degree phase shifts obtained from a series resonant circuit or from a doubly tuned transformer.

ter oscillator phase, and were chrominance phase to have a suitable compensating lag or lead, all reproduced colors would come out just as they did before the shifts were made.

In actual practice the chrominance signal is not formed at the transmitter by combining R-Y and B-Y color -difference voltages. Instead, as shown by Fig. 27, the 3.58-mc output of the master oscillator is shifted 57° before going to either modulator. Then this 3.58-mc voltage with a 57° shift is fed to one demodulator, and to the other demodulator is fed a 3.58-mc voltage shifted an additional 90° .

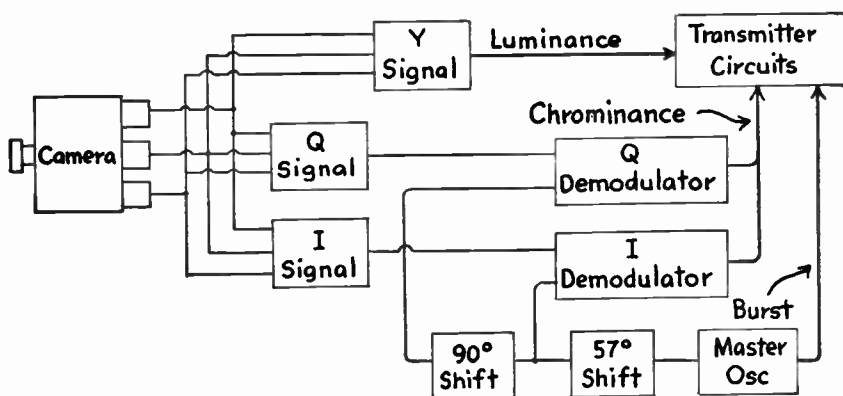

Fig. 27.—Chrominance signals are formed at the transmitter by combining 3.58-mc voltages which are modulated by the Q-signal and by the I-signal.

When these two 3.58-mc voltages are modulated by color signals from the camera system the modulated outputs are not called R-Y and B-Y. At the modulator whose 3.58-mc voltage is shifted only 57° we have what is called the I-signal. At the modulator whose 3.58-mc voltage has been shifted an additional 90° we have the Q-signal. The letter *I* stands for *In-phase*, while the letter *Q* stands for *Quadrature phase*.

The voltages modulated by the I-signal and the Q-signal combine to form the chrominance signal that is transmitted. The reference phase that is sent out as the burst signal is still that of the master oscillator; before the oscillator phase is shifted either 57° or an additional 90° .

Relations between the reference phase of the burst voltage and phases of I, Q, R-Y, and B-Y signals are shown by Fig. 28. This

chart shows also the phases of chrominance signals for primary and secondary colors. Note that there is a 33° phase difference between $+I$ and $+(R-Y)$, and a similar phase difference between the other I or Q signals and the color-difference signals $R-Y$ and $B-Y$.

The chrominance signal formed by combining the I and Q signals is received and carried through the chrominance amplifier to the demodulators. If phase of the color oscillator in the receiver is shifted 33° before going to either demodulator, and shifted an additional 90° before going to the second demodulator, output of one demodulator will be $R-Y$ color difference signals, and of the second demodulator will be $B-Y$ color-difference signals. The shift of 33° is required because this is the phase difference between I or Q signals and $R-Y$ or $B-Y$ signals.

If color oscillator phase is not shifted 33° before going to either demodulator, output from one demodulator will be the I signal and from the other will be the Q signal. Some receivers demodulate to cover I and Q signals. Others shift the color oscillator phase 33° and recover $R-Y$ and $B-Y$ signals. Which signals are recovered depends on phasing of color oscillator voltage with respect to the reference phase of the burst signal.

The same primary and secondary color signals, as well as signals for all other colors, may be produced from either the I and Q signals or the $R-Y$ and $B-Y$ signals at demodulator outputs. For example, red results from 62% of a $+(R-Y)$ signal and 15% of a $-(B-Y)$ signal. Note that the red chrominance phase on the chart Fig. 28 is between $+(R-Y)$ and $-(B-Y)$. Red may be produced also from 60% of the $+I$ signal and 21% of the $+Q$ signal. Red on the color phase chart is between the $+I$ and $+Q$ signal phases.

Any color signal or color voltage may be produced from appropriate fractions of $R-Y$ and $B-Y$ phases between which lies the phase of a color in question. The same color may be had from suitable fractions of I and Q signals between which is the color phase being considered.

The 33° phase shift which allows demodulation to recover $R-Y$ and $B-Y$ signals may be performed almost anywhere between the point at which the burst voltage is separated from the composite color signal and the output of the color oscillator. It is necessary

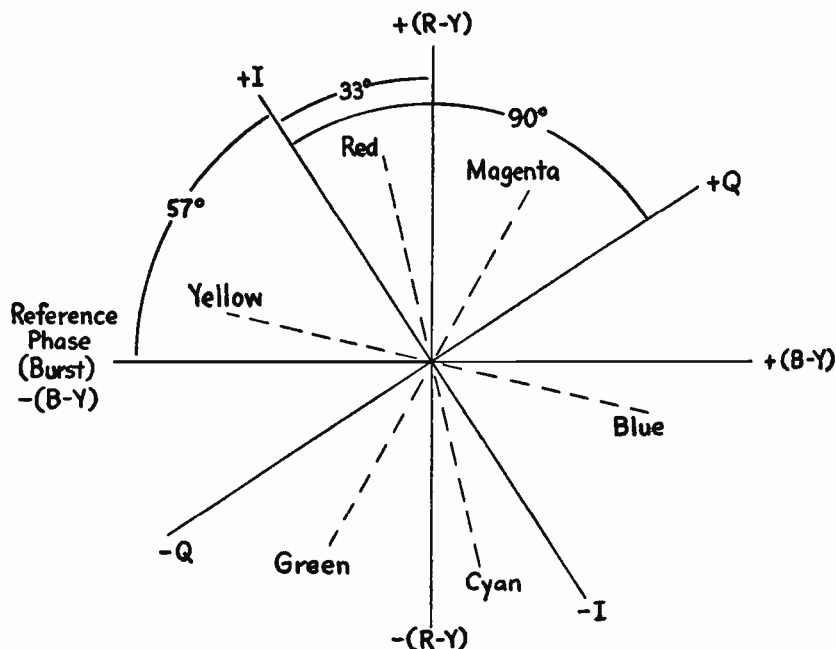

Fig. 28.—Phase relations of the reference burst voltage and the various color signals.

only that the 3.58-mc voltages to the two demodulators be shifted 33° with respect to phase of the burst signal.

Luminance Amplifiers. — In diagrams of Fig. 29 are shown several parts found in luminance amplifiers. These parts include a delay line, peakers for high-frequency compensation, and one or more traps. One trap will be tuned for 3.58 mc, to prevent burst voltage or color oscillator voltage from reaching the picture tube. In addition there may be traps for accompanying sound and for the 4.5-mc intercarrier beat frequency. Except for the delay line and the 3.58-mc trap the luminance amplifier section is quite similar to a video amplifier section in a black-and-white receiver.

In the complete diagram at the top of Fig. 29 the luminance signal is taken from an i-f amplifier through a crystal detector which is generally similar to a crystal type video detector. In the lower partial diagram the luminance signal is taken from the output of a video amplifier tube.

ulation. Delay lines seldom are interchangeable between different receivers.

Delay line units in receivers look quite like a piece of large diameter coaxial cable, six inches or more in length. There are various internal constructions, including elements such as coiled conductors separated by dielectric material from metallic braid covered on the outside with protective insulation. There may be a magnetic core, or many small inductors in series with capacitances to ground from between them. Sometimes there is no delay line constructed as a unit, but equivalent delay action is provided by inductances and capacitances in various parts of circuits in which delay is required.

Black-and-white Reception.—When a black-and-white picture transmission is to be used in a color receiver the chrominance section is made inoperative. Then, in receivers having demodulators connected to picture tube control grids, there are no color signals to vary the grid voltages. The grid-cathode voltages of the picture tube will have been so adjusted that, with no signals received, the three electron beams are of relative strengths exciting the blue, green, and red phosphors for the sensation of white or gray light. Under this condition, the deflected beams will produce a white or gray raster.

If voltage on the three cathodes is varied, with relative strengths of grid voltages remaining unchanged, there will be white, gray, or black on the viewing screen. Variations of cathode voltage will vary the strengths of all three beams at the same time.

Assume now that a black-and-white composite signal is received. It has everything that is in the composite color signal except the chrominance information and the burst signal. The black-and-white passes through the tuner, the i-f amplifier, the video or luminance detector, and through the luminance amplifier section of the color receiver, just as would the luminance portion of a color signal.

The black-and-white signal acts on all three cathodes in the picture tube, and causes simultaneous variations of all three electron beams without altering their relative strengths. Then pictures appear only as variations of gray, or appear in black-and-white.

In some color receivers the three control grids, instead of the three cathodes, of the picture tube electron guns are tied together. To the grids is applied the luminance signal or a black-and-white signal. In this case the three cathodes are individually connected to outputs of the demodulators or color amplifiers, and are affected by color signals while the chrominance section is in operation. Reproduction of black-and-white pictures would be just as effective as with grid and cathode connections assumed in the preceding explanations.

The chrominance section may be made inoperative in various ways. In some receivers the saturation control is turned to its minimum position. Inasmuch as this control is a gain control for the chrominance amplifier, amplifier gain thus may be reduced to zero and no chrominance signals will pass through the demodulators. With other designs the plate or screen voltage is removed from demodulators, which reduces demodulator output to zero.

In many receivers there is a color killer tube and associated circuits which automatically bias the chrominance amplifier to cutoff except while color signals are received. When color transmissions are received, the bursts which accompany the signals are utilized in the color killer circuits to remove the cutoff bias from chrominance amplifier tubes.

Directing the Electron Beams.—Many of the service adjustments in color television are for the purpose of getting the three electron beams through openings in the shadow mask and onto the correct phosphor dots of the viewing screen. All three beams must meet at the same mask opening no matter to what point on the mask the beams are deflected. Then, in the small distance from mask to viewing screen, the beams must separate so that each strikes only a phosphor dot whose color corresponds to the color signal in the gun where the beam originates.

Principal causes for difficulties are illustrated by Fig. 30. To begin with, the beams start from three guns which are separated from one another by considerable distances. If the three beams are to meet at the same tiny opening through the mask, in spite of manufacturing tolerances in gun structures and positions, some of the beams must be bent or deflected differently than others.

The mask and the phosphor plate or viewing screen do not have exactly the same curvatures, and the two curves do not have their centers at the same point along the tube axis around which are the electron guns. Consequently, even though the beams come together at openings near the center of the mask, when deflected toward the edges the beams tend to come together at a point back of the mask. Were this effect not counteracted, the beams would separate before reaching openings in the mask, and could not pass through at such angles as to strike the proper phosphor dots.

Bringing the three electron beams together at openings in the shadow mask over its entire area is referred to as convergence. Insuring that each beam strikes only a phosphor dot of correct color is referred to as purity. Elements mounted around the neck of the picture tube for purposes of obtaining correct convergence and purity are shown by Fig. 31.

Convergence. — Two kinds of adjustment are required for bringing the three electron beams together at the same opening in the shadow mask. First there is so-called static convergence adjustment, intended to bring the beams together at openings in the center and close to the center of the shadow mask. Second

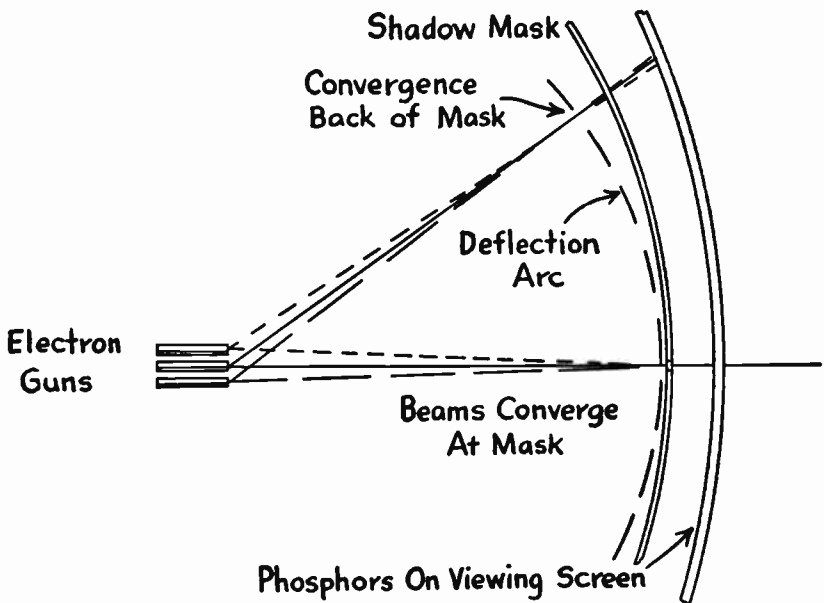

Fig. 30.—The beams tend to converge at different distances when near the center of the shadow mask and when deflected toward its edges.

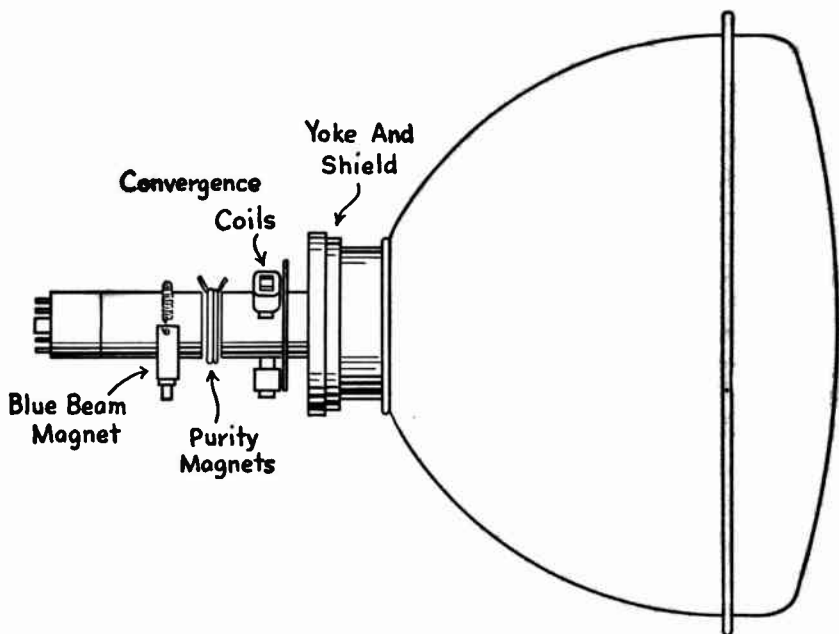

Fig. 31.—Elements mounted on the neck of a color picture tube for obtaining convergence and purity.

there is dynamic convergence adjustment for bringing the beams together when they are deflected away from the center of the mask.

Directions taken by the three electron beams in traveling from guns to mask are varied by means of three electromagnets, called convergence coils, which are equally spaced around the outside of the tube neck. These magnets are shown by Fig. 32. Each coil is directly outside one of the electron guns. Inside the tube neck, mounted on the gun structure, are three sets of magnetic pole pieces.

Each beam passes through the space between a pair of pole pieces, wherein is a magnetic field induced from the external coils. Magnetic field lines extend straight across from one pole to its mate. Since a magnetic field tends to move an electron beam at right angles to the field lines, each beam may be moved directly toward or away from the tube axis by changing the polarity and strength of the magnetic field, or by changing the direction and strength of current in a convergence coil.

To obtain static convergence, at and near the center of the shadow mask, a direct current may be passed through each of the coils in the design at *A* of Fig. 32. With other designs, shown at *B*, static convergence is obtained by means of small permanent magnets mounted within a gap of the electromagnet core. Rotating the permanent magnet one way or the other adjusts static convergence.

With still other designs, static convergence is adjusted with the help of three small permanent magnets held on adjustable brackets around the outside of the tube neck near the convergence coils. Changing the positions of these magnets, or reversing them end for end in the brackets, adjusts each beam for static convergence. With any of these designs, dynamic convergence is brought about by coil currents which vary proportionately to the degree of beam deflection.

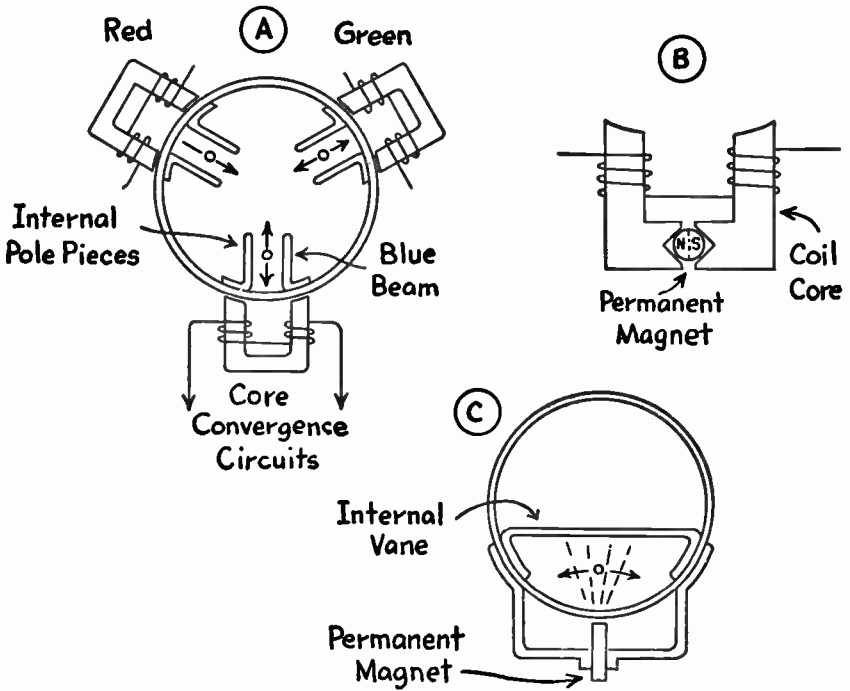

Fig. 32.—Constructions of the convergence coils and of the blue beam magnet.

Static convergence adjustments which depend on convergence coil currents or associated permanent magnets shift the paths of red and green beams in such directions that they are bound to meet at some point whose location may be altered by the adjustments. But the path of the blue beam will not necessarily pass through the same point; it might go to one side or the other. Therefore, it must be possible to shift the path of the blue beam not only as at *A* of Fig. 32 but also at right angles to that direction in order that all three beams may come together at the same point.

The path of the blue beam may be shifted crosswise of the neck axis, and at right angles to directions indicated at *A*, by adjustment of the blue beam magnet. Action of this magnet is illustrated at *C* of Fig. 32. Outside the tube neck, in line with the blue gun, is a permanent magnet mounted with one end toward the glass. The magnetic circuit is completed by extensions on opposite sides of the permanent magnet and by a magnetic vane inside the tube, mounted on the electron gun. The magnetic field inside the tube neck is in the direction of broken lines. The path of the blue beam is shifted at right angles to these field lines. How far the blue beam is shifted depends on spacing of the blue beam magnet from the neck of the tube. Direction of shift is determined by whether the north or south magnetic pole is toward the neck. The blue beam magnet may be turned end for end in its mounting.

Dynamic Convergence.—While the electron beams are being deflected vertically and horizontally the angles at which they are bent must be altered proportionately to the distance of deflection. Changes of deflection angle are caused by currents in the convergence coils, and resulting magnetic fields between the internal pole pieces at *A* of Fig. 32. Varying the coil currents varies the angles of beam deflection.

Various arrangements of circuit elements are employed in different color receivers for producing convergence coil currents of waveforms that cause necessary changes of beam angles during deflection. The general principle is illustrated by Fig. 33.

From a winding on the horizontal sweep transformer are obtained voltage pulses at the horizontal line frequency or horizontal sweep frequency. These pulses pass through horizontal amplitude controls and horizontal wave shaping circuits. The wave

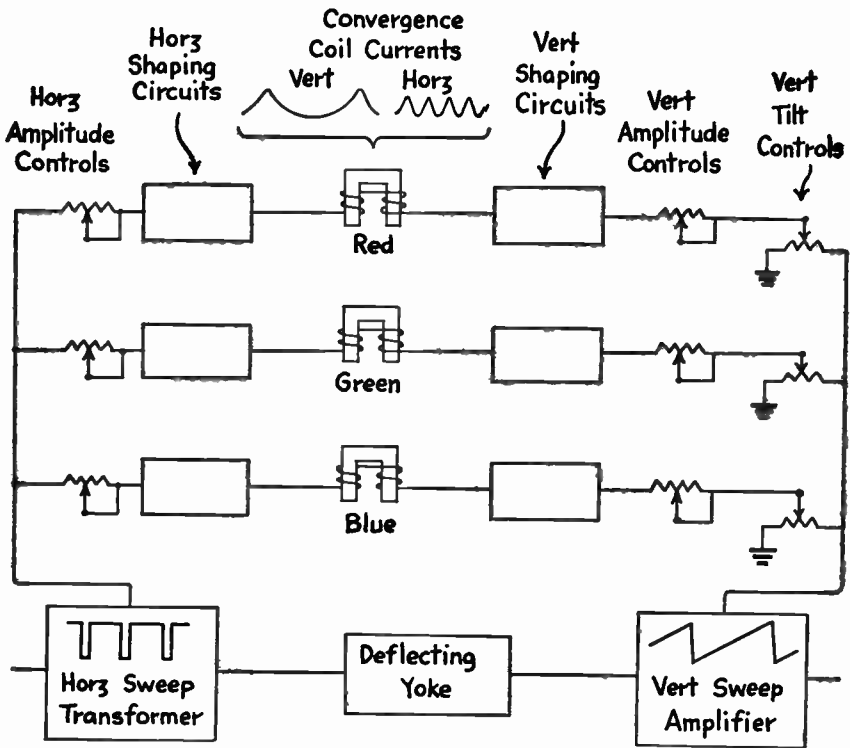

Fig. 33.—The principal parts of dynamic convergence circuits.

shaping circuits are either parallel resonant or series resonant at the horizontal sweep frequency, and they produce approximate sine waves when excited by the voltage pulses. Any resonant circuit having reasonably small energy losses will maintain oscillatory currents of approximate sine wave form when energy is supplied by practically any voltage waveform at the resonant frequency. The shaping circuits are of such design that output currents are of parabolic waveform, consisting of loops between relatively sharp peaks. This is the waveform required for dynamic convergence.

From the vertical sweep amplifier are obtained sawtooth waves at the vertical sweep frequency. These waves pass through tilt controls and vertical amplitude controls to vertical wave shaping circuits. The vertical wave shaping circuits produce output currents of parabolic waveform at the vertical sweep frequency.

Horizontal and vertical parabolic currents combine in windings of the convergence coils. The higher-frequency horizontal waves ride on the lower-frequency vertical waves to cause proper dynamic convergence during both horizontal and vertical sweeps of the electron beams.

The tilt controls are, in effect, additional wave shaping devices that shift the vertical current loops one way or the other by varying the strength, or both strength and polarity, of the vertical sawtooth waves furnished to the wave shaping circuits. That is, these controls tilt the vertical parabolic waves as may be required. In some designs there are separate tilt windings on the cores of the convergence coils. In other designs there are horizontal tilt controls in addition to vertical tilt controls.

Purity Controls.—Even though all three electron beams come together at openings in the shadow mask, it still would be possible for one or more of the beams to pass through at such an angle as to strike a phosphor dot of wrong color, or to strike two or more dots at the same time. The dots are arranged in perfectly regular triangles, and unless the beams approach the mask openings in perfectly triangular formation there will be wrong coloring or possibly lack of saturation in pictures.

Correction is by means of ring-shaped permanent magnets or an electromagnetic coil around the outside of the tube neck between the convergence coils and the blue beam magnet. These purity magnets or the purity coil produce magnetic field lines which pass through the tube neck at right angles to its axis and to the direction of beam travel. This crosswise magnetic field acts simultaneously on all three beams, and aligns the beams so that they approach the shadow mask at correct angles.

Purity adjustment requires changing the position of the magnetic field that passes crosswise through the tube neck, and varying the strength of this field. Direction of the field across the tube neck, or its angular position in relation to the electron guns, is varied by rotating the two magnetic rings or the single purity coil around the tube neck. Strength of the magnetic field is changed by varying the relative positions of gaps in the magnetic rings, as with a double-magnet centering device, or by adjusting the direct current in a purity coil.

Although purity may be chiefly affected by adjustments of purity magnets or purity coil, it is affected also by static convergence adjustments of convergence coils and cores and by adjustment of the blue beam magnet. Purity is affected also by position of the deflection yoke along the tube neck. Moving the yoke toward or away from the flare of the tube may be necessary in securing good color purity.

Chapter 19

SERVICING COLOR RECEIVERS

In a color receiver there are more circuits and components than in a black-and-white or monochrome set, therefore more places in which trouble may occur. To cut down the number of places to be checked, and thus save time, it is essential to apply the principle of sectionalizing. That is, symptoms of trouble appearing at the picture tube and on an oscilloscope are observed and analyzed with the object of limiting the detailed tests and measurements to sections probably at fault, while eliminating other sections from suspicion.

The first step is to try obtaining a uniformly white or gray raster while no signals are applied. The second step is to check the reception of black-and-white programs or test patterns. The third step is to check reception of a color program or to work

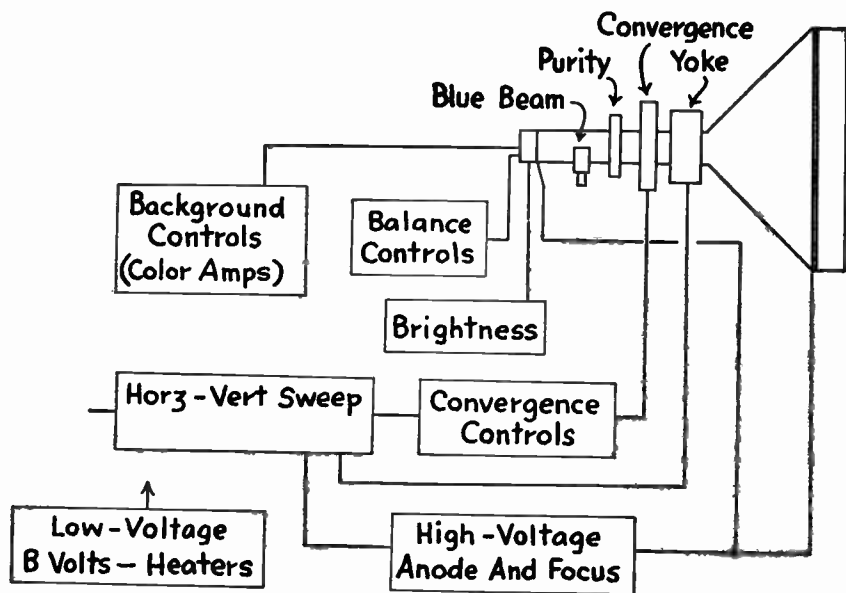

Fig. 1.—These are the sections most probably at fault when a colorless raster cannot be obtained.

with signals from generators especially designed for color trouble shooting.

To examine the raster, disconnect the antenna and place the station selector on a channel not used locally. Turn on the set and allow plenty of warmup time. Set the saturation control at minimum, and if there is a switch for selecting color or monochrome place it in the monochrome position. Adjust the brightness control for moderate illumination of the viewing screen; too much brightness may cause coloring on a raster even though normal reception would be satisfactory.

If the raster is uniformly white or gray, free from all coloring, it may be assumed for the time being that sections represented by the blocks in Fig. 1 are in good operating condition. Illumination of the entire viewing screen proves that there is anode voltage, that horizontal and vertical sweep and deflection systems are operating, and that the low-voltage supply is working. If there is no coloring it is certain that the three kinds of phosphors are blending their lights in the proportion required for white or gray. This is possible only when the three electron beams are striking phosphor dots of proper colors, and when balance and color gain controls are correctly adjusted.

Should coloring appear only near the edges of the raster it is possible that purity adjustments are incorrect. Appearance of color only when brightness is high, or very low, may indicate wrong adjustment of gain controls on color amplifiers. Mottled coloring all over the viewing screen usually means that the chrominance amplifier is operating when it should be cut off. This would mean trouble in a color killer system or with whatever means is employed to make the chrominance amplifier inoperative when no color signals are received.

Inability to obtain a white or gray raster most often indicates misadjustment of purity controls or convergence controls, although the fault might be in color matrix or amplifier circuits, or even in the picture tube itself. In any event, failure to obtain a good monochrome raster means that the cause most probably is in sections or controls of Fig. 1.

Provided the monochrome raster is satisfactory, the antenna is reconnected and the station selector set for a channel in which there is a local black-and-white transmission. Faults in black-

and-white pictures or test patterns, when the raster has proven satisfactory, usually indicate trouble in some of the sections whose names are shown on the blocks of Fig. 2.

Except for the luminance amplifier and convergence controls all the sections of Fig. 2 operate similarly to equivalent sections in a black-and-white set. The luminance amplifier is quite like a video amplifier, but contains a delay line. Unless this line is open or grounded it will not affect monochrome reception.

A fault which may show during monochrome reception, even though the raster proved satisfactory, is called color fringing. At the outlines or boundaries of objects are various colors. The probable cause is misadjustment of convergence controls.

It is possible also that small amounts of one color may appear within larger areas of another color which should be solid. This fault may result from wrong static or dynamic convergence adjustments, or from incorrect positions along the picture tube neck of purity magnets or coil, or of the deflecting yoke.

During reception of black-and-white pictures or a test pattern it is in order to make those service adjustments which would be performed on a black-and-white or monochrome receiver. These adjustments would be for size, linearity, horizontal drive, for centering, horizontal and vertical hold, and horizontal afc.

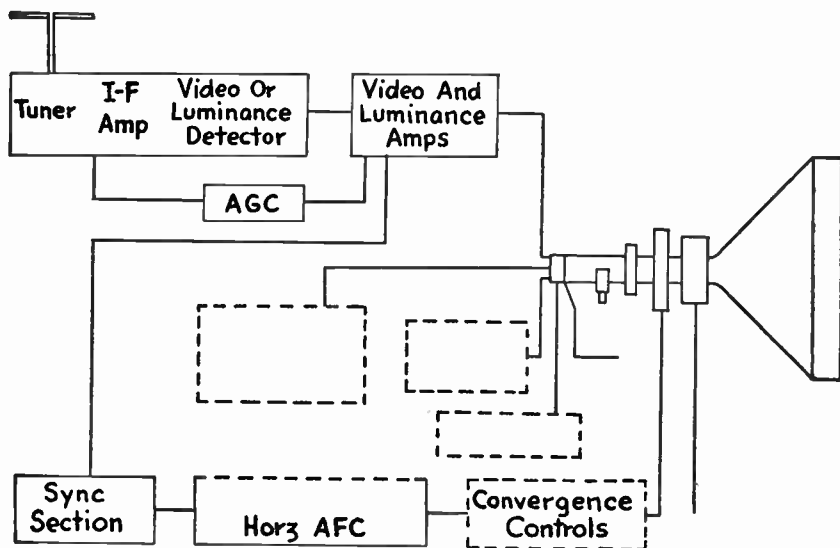

Fig. 2.—These are the sections most likely to have troubles which prevent satisfactory black-and-white reception.

If black-and-white reception is satisfactory or has been made so it may be assumed that sections names on Fig. 2 are in good operating condition, at least until some of them prove later to have faults which affect color reproduction.

Color Reproduction Faults.—The blocks of Fig. 3 represent receiver sections and controls in which troubles may cause poor reproduction of color programs. Blocks with broken outlines are least likely to be at fault, because most difficulties will have been discovered and corrected during the check of black-and-white reception. However, these parts may have troubles that affect only color reproduction. If these are evidences of trouble it ordinarily will be necessary to use a color bar generator for signal input during tests and corrections.

The more common effects noted for faulty color reproduction, and their probable causes, are listed in following paragraphs.

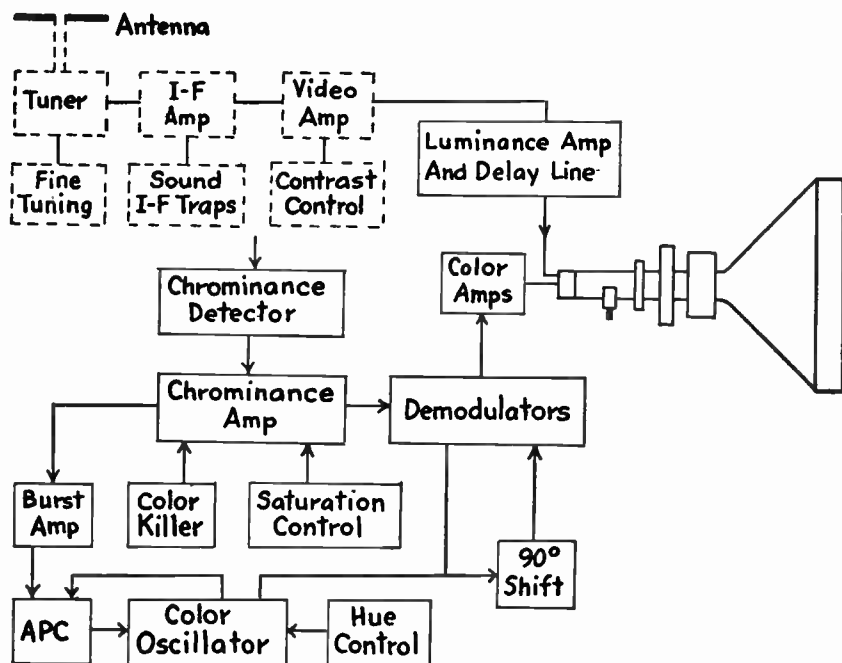

Fig. 3.—Troubles in any of these sections may prevent satisfactory reproduction of color pictures.

Color absent or very weak.

Saturation control misadjusted, or circuit trouble.

Fine tuning misadjusted.

Contrast control set too low.

Narrow-band response in i-f amplifier, tuner, booster, or antenna.

Color killer, if present, holding chrominance amplifier at cutoff. This might be due to a weak or missing burst signal.

Chrominance amplifier not properly aligned.

Demodulator outputs too weak.

Burst amplifier circuits not aligned.

Automatic phase control (APC) misadjusted.

Color oscillator circuits not correctly aligned.

Color oscillator crystal defective, or circuit trouble.

Color too strong.

Trouble in saturation control or circuit.

Luminance section gain too low.

Fine tuning misadjusted.

Contrast control set too high.

Vari-colored outlines. This may be called color fringing or edging. It is somewhat equivalent to smearing or ringing in monochrome reception. Frequency response of the luminance section should be observed, in the same manner as response of a video amplifier. Some causes for trouble are:

Delay line of wrong value, open, grounded.

Accompanying sound traps misadjusted.

Peakers faulty in detector or luminance amplifier circuits.

Dressing of wiring has been altered.

Hum bars. The appearance is similar to hum bars in monochrome receivers, and causes are the same, but the bars appear in colors. Color sections in which trouble exists sometimes may be located by noting the colors of the bars, as follows:

Red and blue-green, check R-Y circuits.

Blue and yellow, check B-Y circuits.

Orange and cyan, check I circuits.

Green and magenta, check Q circuits.

Color bars in motion. The effect is somewhat similar to diagonal bars on a monochrome viewing screen when horizontal

hold is at fault. The cause is that the color oscillator frequency is not synchronized in relation to phase of the burst signal. Check the following:

Automatic phase control (APC) adjustments.

Color oscillator crystal or crystal circuit.

Frequency response of i-f amplifier and video amplifier; may be too narrow.

Interference of receiver voltages.

Speckles or dots usually mean that either the 3.58-mc color oscillator voltage or else the 4.5-mc intercarrier beat voltage is getting through the luminance section to the picture tube. Check adjustment of traps for these frequencies.

Coarse bands of color which shift between vertical and sloping positions indicate beating at the picture tube input of the 3.58-mc color oscillator voltage and the 4.5-mc intercarrier beat voltage to produce beat lines from the resulting frequency of approximately 0.92 mc or 920 kc. Check adjustment of traps for the beating frequencies. Fine tuning misadjustment might be the cause.

Moving bands of color or wrong colors may indicate that ghost signals or reflected signals are reaching the antenna.

Wrong colors or hues.

Observe objects whose correct coloring is known, such as flesh tones of people in the pictures. The most probable reason for incorrect color is lack of phasing in the color oscillator output voltage, which may result from the following:

Hue control misadjusted.

Misadjustment of 90° phase shift circuit.

Automatic phase control (APC) misadjusted.

Burst amplifier circuits not aligned.

Burst voltage weak or lacking. Check i-f amplifier, detector, and other circuits through which burst signals come to the burst amplifier.

Less likely causes for wrong colors would be weak output from the luminance amplifier, which might darken greens and yellows, or trouble with the delay line.

If people and objects change their coloring when moving between the center and the sides of the viewing screen the probable cause is purity misadjustment.

Color Overcast.—Sometimes the entire viewing screen will be strongly tinted or overcast with some one color or shade. The effect is quite like that observed in novice color photography, when an entire picture may be strongly tinted with blue or some other shade. In photography the primary cause is failure to filter out the excess of the overcasting color. In color television the cause usually is lack of some color signal, which leaves complementary color too strong.

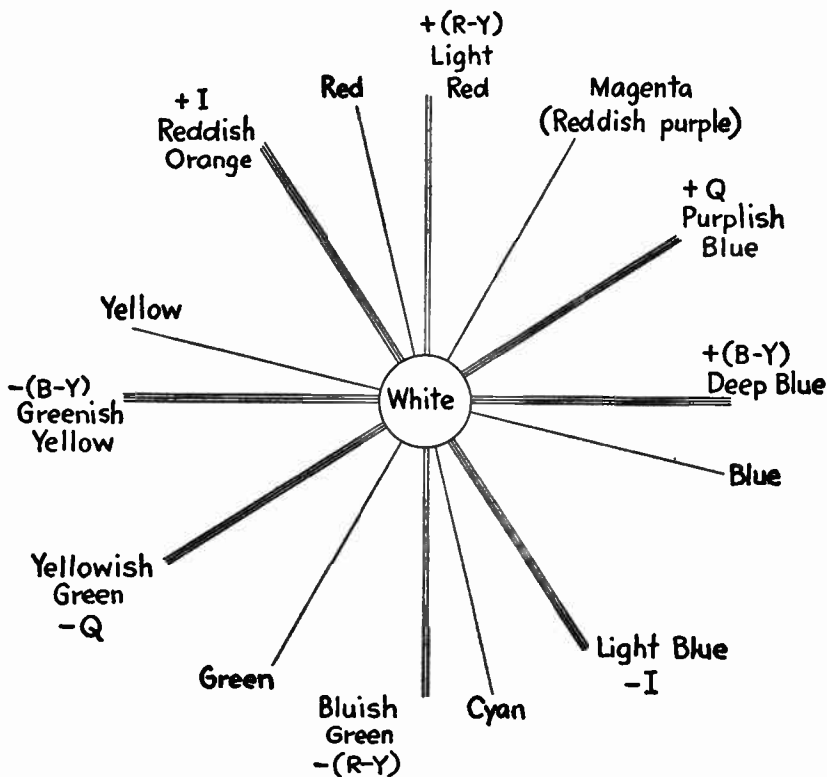

Fig. 4.—When any of these colors are missing or weak, the opposite complementary color usually appears too strong.

The thing to do is try identifying the missing color, then look for trouble in sections and circuits which supply that color. Since a color that is not present is difficult to identify, it is easier to note the overcasting shade and look for its complementary on a color phase chart such as that of Fig. 4. Any two colors which are opposite are complementary. When blended in suitable proportions, any two complementaries produce the sensation of white, as indicated at the center of the chart.

As an example, assume that pictures are tinged all over with bluish green. On the chart this corresponds to $-(R-Y)$, which is present in excessive strength. The complementary is $+(R-Y)$, which would be weak or lacking. The procedure is to examine circuits and components that should furnish the $+(R-Y)$ signal voltages. Were the overcast to be yellow or light orange, the complementary blue would be weak or missing.

It should be noted that this method of analysis does not apply when an entire color signal, both positive and negative, is missing or very weak. For instance, were the entire $R-Y$ signal or the entire I signal missing, all colors would be altered. This is true because all color phases result from combinations of $R-Y$ and $B-Y$, or from combinations of I and Q signals.

Instruments for Color Servicing.—For properly servicing all the color sections shown by Fig. 3 it is necessary to have a color bar generator and a wide-band oscilloscope. The color bar generator furnishes signals which are the equivalent of regular 3.58-mc chrominance signals and 3.58-mc burst voltages, so far as service tests are concerned. In addition, some of these generators furnish a luminance carrier, a sound carrier, and sync pulses. A good color bar generator takes the place of a transmitted color and sound program signal so far as service work is concerned.

With the color generator connected to the antenna terminals or else to a point beyond the detectors, the picture tube of a correctly adjusted receiver will display color patterns of styles depending on the particular generator. An RCA color bar generator produces the pattern of Fig. 5. There are ten vertical bars in colors, with dark or colorless bars between. The colored bars result from chrominance phases separated by 30 electrical degrees, commencing at 30 degrees from the reference phase and continuing around the color phase chart to 300 degrees. The colored

bars represent $+(R-Y)$, $-(R-Y)$, and $+(B-Y)$, also $+I$, $-I$, and $+Q$, and certain intermediate color phases.

There are differences between color generators and what they will do. Depending on the instrument, it is possible to perform some or all of the following service operations: Determine which color section is in trouble. Check phasing of color oscillator output, and action of the hue control. Adjust the automatic phase control circuits. Check action of a color killer, or various traps, and of the luminance delay.

Used with an oscilloscope to observe outputs of various stages, the color generator allows checking effects of demodulator and amplifier gain controls, action of matrix circuits, and adjust-

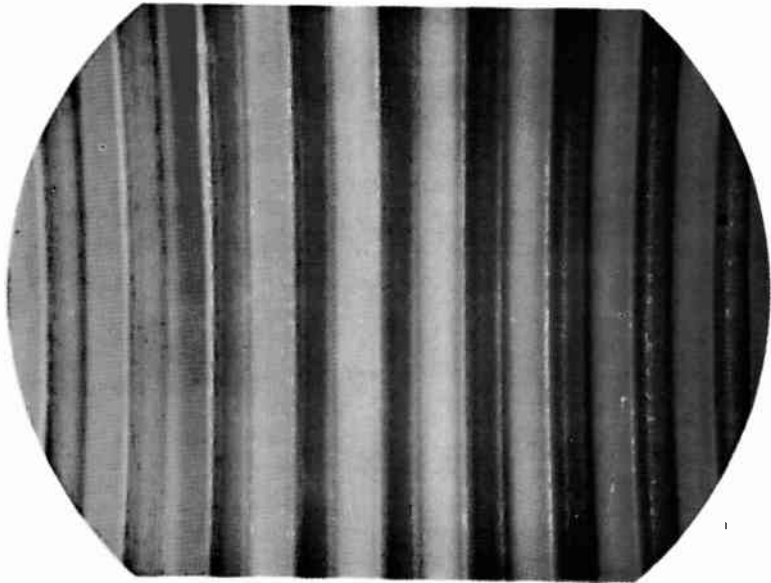

Fig. 5.—Pattern produced by one type of color bar generator.

ments or alignment for 90° phase shift. For work in circuits carrying 3.58-mc voltages a wide-band oscilloscope is needed. Such work includes signal tracing in color oscillator and chrominance sections, also checking alignments throughout the color oscillator section, including the burst takeoff, burst amplifier, and crystal circuit.

A wide-band oscilloscope is needed wherever 3.58-mc voltages are to be observed, because ordinary service oscilloscopes have zero or practically zero vertical gain at this frequency. Instruments designed for color or suitable for color servicing have vertical frequency response down not more than two to five decibels at frequencies of four to five megacycles.

The wide-band scope should have practically flat frequency response in order that amplitudes of 3.58-mc voltages and of other voltages in the chrominance range may be compared by using a peak-to-peak calibrator. Vertical sensitivity may be on the order of 0.03 to 0.04 volt per inch at frequencies around four megacycles. A low-capacitance frequency compensating probe must be used on the oscilloscope vertical input. All the wide-band instruments have frequency compensating vertical attenuators.

Marker generator frequencies must be more accurate than required for ordinary servicing of black-and-white receivers. The 3.58-mc frequency must be crystal controlled or calibrated, and similar precision is needed for intermediate frequencies near the low end of the i-f response, where the curve drops down toward the sound intermediate.

A sweep generator for color work should be of good quality, operating on fundamentals, with output flat through any frequency range to be swept, and with good linearity. For observing frequency responses of video amplifiers, luminance amplifiers, and chrominance amplifiers the generator must be capable of sweeping a range from about 50 cycles to five or six megacycles per second.

For convergence adjustments it is highly desirable to have a pattern generator which produces on the viewing screen of the picture tube a series of regularly spaced dots or else a crosspatch of vertical and horizontal lines. Dots or lines should be bright, on a dark background. When such an instrument is called a dot

generator it ordinarily provides either dots, a crosshatch pattern, horizontal lines, or vertical lines. Any of these patterns may be used for adjusting linearity, size, and centering.

The pattern generator may be connected to receiver antenna terminals or to the input of a video amplifier. The instrument should deliver a waveform that synchronizes the receiver horizontally and vertically, or else there should be provision for taking synchronizing pulses from receiver to generator. This is necessary for maintaining a stationary pattern on the viewing screen.

Misadjustment of the convergence controls will result in a separation of the three primary colors. Figs. 6A and B illustrates improper convergence. Fig. 6C indicates correct vertical dynamic convergence, and Fig. 6D indicates the white dot pattern produced when all convergence adjustments are correct.

ALIGNMENT AND ADJUSTMENT

All precautions ordinarily observed during alignment and adjustment of monochrome receivers are as important, or more so, when working on color receivers. Generator outputs should be kept as low as possible, high-side and ground connections should be close together, instrument leads should be shielded, generator cables properly terminated, and all the rest. Color sets may have series heaters and hot chasses, requiring the use of an isolating transformer. If power line voltage is likely to fluctuate it should be regulated or adjusted to 117 volts during tests. Plenty of warmup time is important.

It is essential that all adjustments which would be made on a black-and-white set be completed before working on any color circuits. This means preliminary checks of controls for size, centering, linearity, drive, hold, and focus.

Frequency Responses.—Incorrect alignment and other faults in tuner, i-f amplifier, and video or luminance detector circuits are corrected by methods employed for black-and-white receivers. Frequency response of the i-f amplifier requires careful alignment, for reasons which follow.

Within the band pass of the i-f amplifier must be all frequencies required for the luminance or Y-signal, also all frequencies for R-Y and B-Y or for I and Q signals. Were only the luminance signal to be passed, without color signals, the response might extend no farther toward the sound intermediate than shown at A,

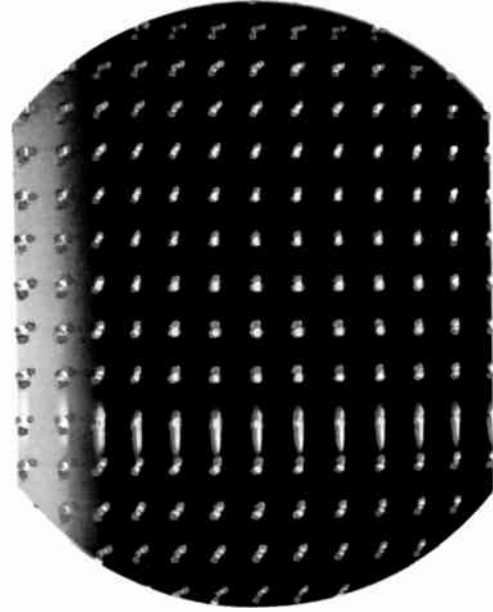

Fig. 6A.—Blue Dots at Center Are Displaced Horizontally by Misadjustment of Lateral-Correction Magnet.

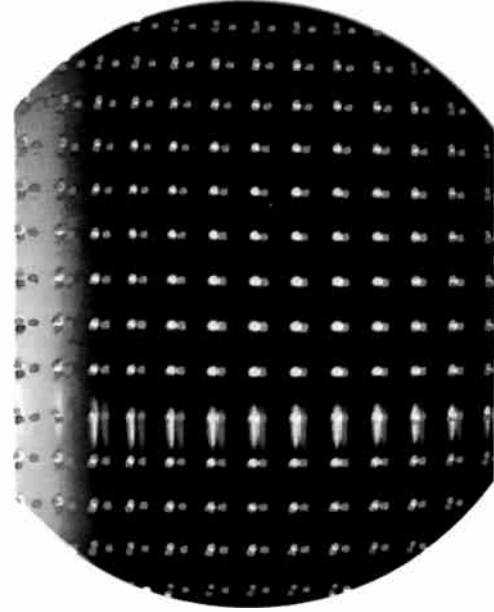

Fig. 6B.—Blue Dots at Center Are Displaced Vertically by Misadjustment of Positioning Magnet for Blue Beam.

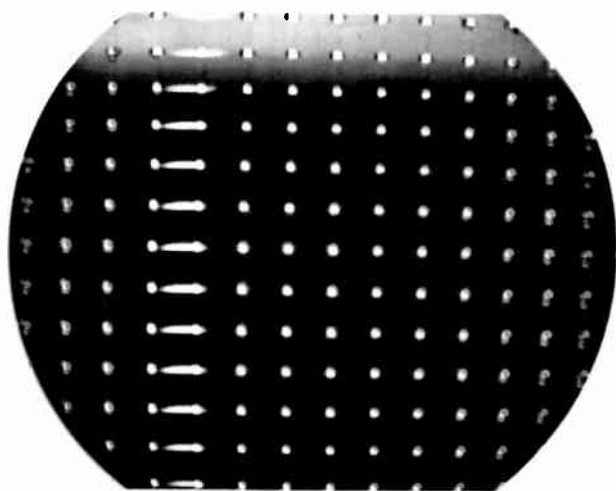

Fig. 6C.—White Dots Along Vertical Center Row Indicate Correct Vertical Dynamic Convergence of All Three Beams.

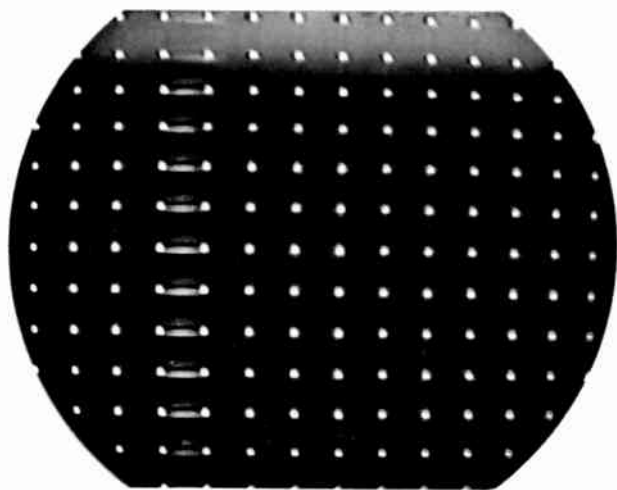

Fig. 6D.—White-Dot Pattern Produced When All Convergence Adjustments Are Correct.

of Fig. 7, which would be satisfactory for a monochrome set.

For a color receiver the i-f band pass must be extended to include the color signal frequencies, which are sidebands of the 3.58-mc subcarrier. For R-Y and B-Y signals, or for a Q-signal, the required responses are about as shown at *B*. For an I-signal the response would be about as shown at *C* were it not cut off on one side.

In order that the color signals may be included within the i-f passband, the i-f response must be as shown at *D*. Since the color subcarrier is 3.58 mc below the video intermediate, the subcarrier frequency will be at 42.17 mc on the i-f response, assuming that the video intermediate is 45.75 mc and the sound intermediate is 41.25 mc.

The i-f response must cut off as sharply as possible above the sound intermediate frequency, usually somewhere between 41.65 and 41.85 mc. This means that part of one sideband of an I-signal (diagram *C* of Fig. 7) will be removed by cutoff of the i-f response, but the other sideband will remain. Unless the i-f response extends as far as possible toward the sound intermediate,

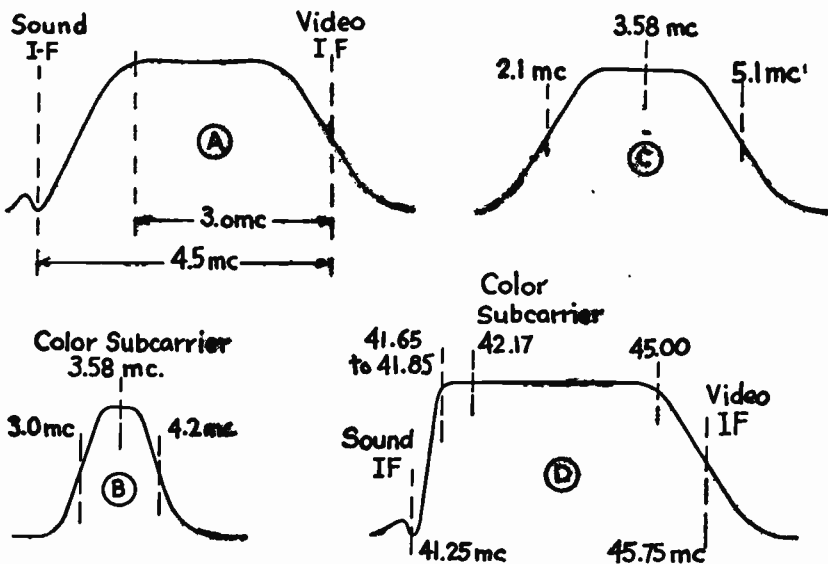

Fig. 7.—Some frequency responses and ranges for video, and chrominance frequencies.

parts of all color sidebands will receive too little amplification. Then colors will be weak or may disappear entirely.

Alignment usually is performed with the oscilloscope connected to the video detector load for the entire process, but with the sweep generator connected for stage by stage checking. That is, the sweep is connected first to the grid of the final i-f amplifier, then moved back a stage or two at a time until connected to the mixer grid. Alignment of couplings and traps commences on the output side of the final i-f amplifier, and continues with adjustment of couplings and traps of additional stages as they are included between the sweep generator connection and the video detector output.

Frequency response of the luminance amplifier or section may be observed with a sweep generator and oscilloscope used in the same manner as for any video amplifier. The luminance response will show effects of 3.58-mc and 4.5-mc traps about as illustrated by dips in the curve of Fig. 8. Peakers maintain high gain to somewhere around 3.0 mc, above which the traps cause dips.

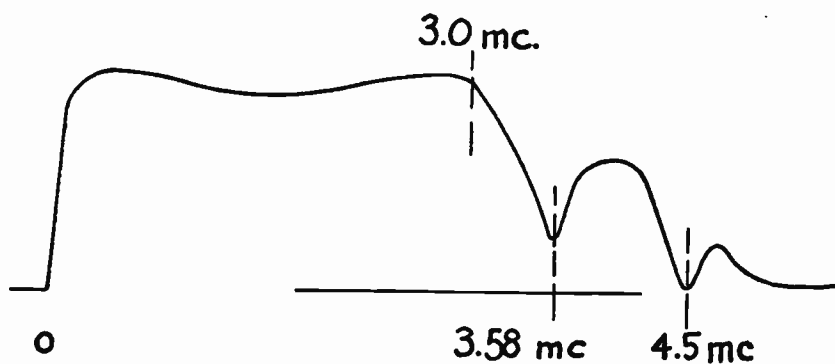

Fig. 8.—Frequency response of a luminance amplifier may show dips at trap frequencies.

Chrominance Amplifier Alignment.—Like every other part of a color television receiver, the chrominance amplifier should be aligned or adjusted in strict conformance with instructions issued by its manufacturer, and the object of alignment should be to secure a response curve of the shape and frequency characteristics recommended in service instructions.

The process is typically about as follows: The station selector is placed on a channel not used locally, contrast is set at maximum or nearly so, and the saturation control is turned to maximum in order to allow full gain in the chrominance amplifier. If there is a color killer, it is disabled in a manner suited to the type of circuit.

The sweep generator is used in the same manner as for observing video amplifier response, sweeping from practically zero to five or more megacycles. Sweep output is applied to the grid of a video amplifier, with the grid disconnected from the preceding detector output but retaining bias voltage.

The oscilloscope is connected to the output of the chrominance amplifier section, which will be the input to demodulators. Sometimes the scope is connected to outputs of stages following a certain trap while that trap is aligned, then transferred to the demodulator input for final curve shape and marker positioning.

The response is shaped and tilted, and markers for required frequencies are placed at knees or cutoffs, by adjusting the couplings and inductors in grid and plate circuits of the chrominance amplifier or amplifiers. The 3.58-mc and 4.5-mc traps are adjusted to show dips on the response.

Color Oscillator Section.—The color oscillator section may be considered as extending from the point at which burst signals are taken from a chrominance or video amplifier, through to the point at which two 3.58-mc voltages are applied to the demodulators, with 90° phase difference between these voltages. All adjustments or alignments in this section are made with respect to the 3.58-mc burst frequency or subcarrier frequency. For work ahead of the oscillator itself, this frequency may be furnished by a crystal controlled or calibrated generator of the marker type or by a color bar generator. When not synchronized by some externally generated 3.58-mc frequency, the color oscillator will operate at what might be called its free running frequency. If

there is a crystal in the oscillator circuit the frequency will be controlled by the crystal.

Adjustments such as found in color oscillator sections are shown on the block diagram of Fig. 9. At the input to the burst amplifier, from the chrominance amplifier or a video amplifier, is a takeoff coupling which is tuned to 3.58 mc. The output circuit of the burst amplifier likewise is tuned to 3.58 mc, and provides the reference input for the automatic phase control system. On the resistor string between the apc diodes is shown a potentiometer for balance adjustment, which may or may not be provided.

The resonant circuit across the reactance tube is tuned to 3.58 mc for phasing the color oscillator with the burst signals. On the plate side of the color oscillator is a tank circuit tuned to 3.58 mc.

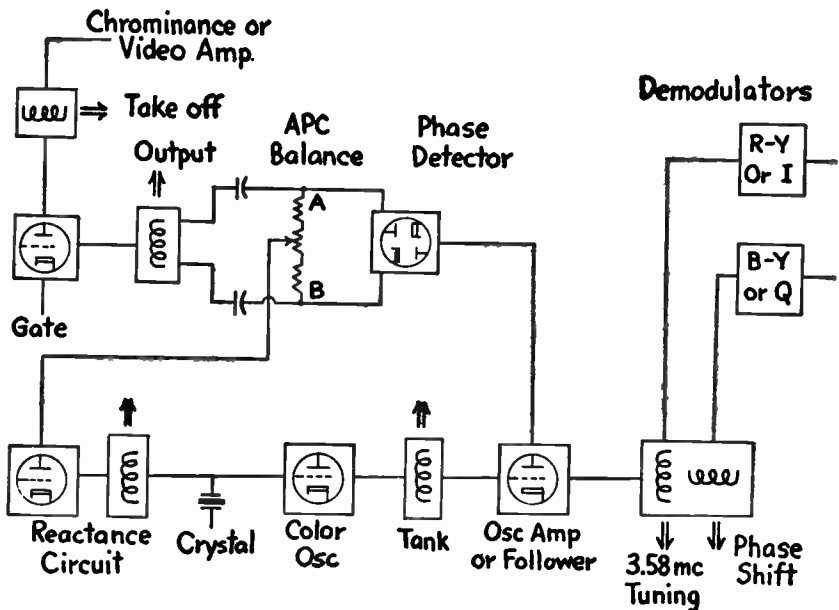

Fig. 9.—Service adjustments in a color oscillator section, between burst takeoff and demodulator inputs.

In receivers having an amplifier or cathode follower on the output of the color oscillator, the amplifier or follower output circuit will have one adjustment for tuning the 3.58-mc input to the R-Y or I demodulator, and another adjustment for 90° phase shift to the B-Y or Q demodulator. Otherwise these two tuned circuits will be on the output of the color oscillator.

Alignments and adjustments in the color oscillator section have three objects. First, to tune all oscillator and oscillator circuits accurately to 3.58 mc. Second, to adjust output from the oscillator section so that 3.58-mc voltages to the two demodulators differ in phase by exactly 90°. Third, to insure that the apc system will control phase and frequency of the color oscillator.

When the color oscillator has a crystal in its grid circuit the tube will oscillate at or very close to the crystal frequency, whether or not a 3.58-mc voltage is applied from some external source, such as from any kind of generator or from bursts in a received signal. The oscillating tube will furnish voltage suitable for alignment adjustments in circuits between it and the demodulators.

The indicator for alignment of the oscillator tank and all following tuned circuits may be a vacuum tube voltmeter used to measure strength of oscillator output voltage. Direct measurement would require a detector probe on the meter, so it is usual practice to connect the VTVM as a d-c meter to a demodulator output or to either of the apc diodes at the element which connects to load resistors between the diodes. Then the demodulator or the apc diode acts as a rectifier and delivers to the VTVM a direct voltage which is proportional to oscillator output voltage.

With the meter connected as mentioned, the oscillator tank and the resonant circuit directly on the plate of any oscillator amplifier or follower are tuned for maximum voltage indication.

The tuned circuit directly on the plate of the last tube in the oscillator section must be aligned alternately with the circuit providing a 90° phase shift until both are correctly resonated. This is necessary because these two circuits are so closely associated that adjustment of either one affects resonant frequency of the other.

When the circuit providing 3.58-mc voltage to a R-Y or I demodulator is correctly tuned there will be maximum voltage out-

put from this demodulator. When the phase shift circuit is correctly tuned there will be maximum output from the B-Y or Q demodulator. With the VTVM on the output from either demodulator the voltage will rise and go through maximum as the tuned circuit for that demodulator is adjusted, but the voltage will dip when the tuned circuit for the other demodulator is adjusted back and forth through resonance.

Automatic Phase Control Adjustment.—Assuming that color oscillator and 90° phase shift circuits have been aligned, a typical procedure for adjusting the burst amplifier and automatic phase control would be as follows.

The input signal may be any 3.58-mc voltage from a crystal controlled generator, or it may be a received color signal, in which there are burst voltages. The generator may be connected to the antenna terminals of the receiver or to the grid of a video amplifier. Contrast and saturation controls are set as for normal reception, the hue control is placed at its mid-position, and, with a generator or received signal at the antenna terminals, the fine tuning control is adjusted for a picture or pattern on the picture tube.

A vacuum tube voltmeter, on its d-c voltage function, is connected to either end of the resistor string between the apc diodes, at the plate of one diode or the cathode of the other, as at A or B of Fig. 9. Then the burst amplifier takeoff or a grid coupling, and also the burst amplifier output circuit, are adjusted for maximum reading on the VTVM.

The VTVM, still on its d-c voltage function, is shifted to the correction voltage output of the apc phase detector, ahead of the noise filter. Now the resonant circuit across the reactance tube, also any balance control on the phase detector, are adjusted for zero reading on the VTVM. The input signal should be weakened, by the attenuator of a generator or by the fine tuning control for a received signal, while readjusting the reactance tube circuit and an apc balance control to maintain zero reading on the VTVM.

High-voltage System.—Three-gun color picture tubes require anode potential of about 25,000 volts and electrostatic focusing potential of 4,000 to 6,000 volts. Because there are three electron beams the total current approaches one milliammeter. Voltage

and current are furnished by a high-voltage supply of the flyback or pulse type employing a doubler or multiplier circuit containing three high-voltage rectifier diodes connected as in Fig. 10.

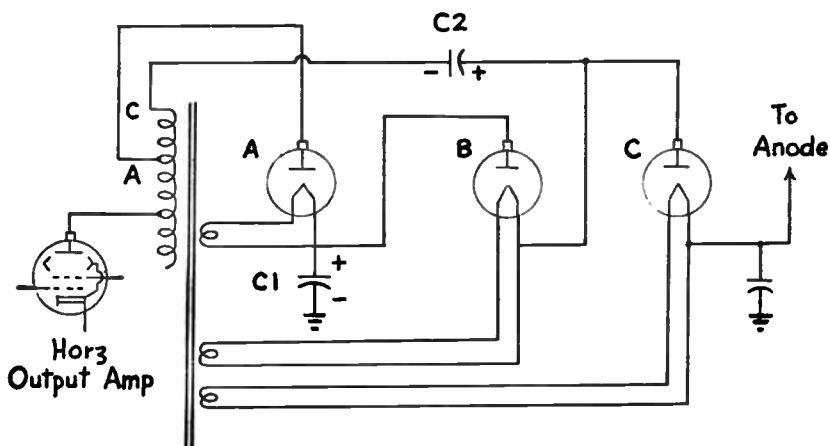

Fig. 10.—The high-voltage doubler system for the anode of a color picture tube.

From tap *a* on the horizontal output transformer, positive pulses of 6,000 to 8,000 volts reach the plate of rectifier *A*. Electron flow from cathode to plate in this tube charges capacitor *C1* in the marked polarity. Positive potential from this capacitor acts on the plate of rectifier *B*, which conducts and couples the positive potential to the plate of rectifier *C*.

At the same time, positive pulses of 18,000 volts or more from *c* on the transformer act through capacitor *C2* on the plate of rectifier *C*. Electron flow in this tube charges capacitor *C2* as marked, with the high positive potential on the plate of tube *C*. This potential and that applied through tube *B* combine at the plate of *C*, and at the cathode of *C* is a total voltage suitable for the picture tube anode.

Potential on capacitor *C1* and at the plate of rectifier *B* is high enough so that, after some reduction through any of various voltage divider circuits, it provides focusing voltage for the picture tube. An adjustable voltage divider for focusing will be connected between the cathode of rectifier *A* and the plate of rectifier *B*.

Because the total of beam currents in the three-gun picture tube is rather large, any decided variations of brightness between picture areas causes large changes of beam current or load current from the high-voltage supply. Unless the load is stabilized, changes of anode voltage which would accompany changes of beam current would affect picture size, coloring, and linearity. Stabilization is secured by automatically regulating the output current and voltage.

One method of voltage regulation is illustrated in principle at A of Fig. 11. To the high-voltage lead for the picture tube anode is connected the plate of a triode designed especially for this work. The cathode of this triode voltage regulator is connected directly or through a B-plus lead to ground. Part of the high-voltage supply current flows in the regulator triode, while the remainder flows as usual in the picture tube.

The grid of the triode regulator might be connected to the slider of a voltage divider potentiometer in a resistor string from the high-voltage lead to ground, but more often the voltage divider is between the focus supply voltage and ground. With either connection, any increase of picture tube anode current such as occurs for a brighter picture area will tend to drop the anode

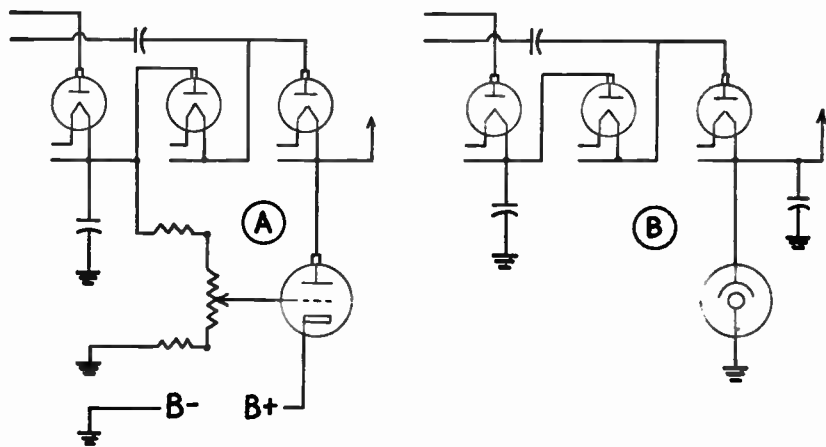

Fig. 11.—A vacuum tube voltage regulator at the left, and a gaseous tube regulator at the right.

supply voltage and at the same time make the triode grid less positive.

A less positive grid in the regulator tube increases internal resistance and reduces plate-cathode current in this tube. Reduced current in the triode compensates for more current to the picture tube anode circuit. Total current from the high-voltage supply remains practically unchanged and, as a result, high voltage on the picture tube anode remains practically constant.

Should there be a decrease of picture tube anode current, as for darker areas of pictures, the high voltage tends to rise. This makes the grid of the triode regulator more positive, lessens internal resistance of the triode, and allows enough more triode current to compensate for decrease of picture tube anode current. Again, high voltage to the picture tube anode remains practically unchanged.

With this kind of automatic voltage regulation the value of picture tube anode voltage and how much it varies may be adjusted by moving the slider on the triode grid potentiometer. The adjustment should be made to allow least change of picture tube anode voltage when the receiver brightness control is varied through its entire range of normal operation. That is, there should be minimum variation of anode voltage when a raster is made alternately bright and very dark.

Another method of automatic voltage regulation is illustrated at *B* of Fig. 11. The principle is that of gaseous or glow tube regulators found in many low-voltage d-c power supplies, but the regulator tube is designed to operate at the high anode voltage for color picture tubes. Internal resistance of a gaseous regulator tube undergoes large changes when there are small variations of the voltage applied between its anode and cathode.

When voltage to the picture tube anode and the gaseous regulator tube tends to rise with decrease of beam currents, more current flows through the lowered resistance of the regulator. Conversely, drop of picture tube anode voltage, as occurs with more beam current, causes less flow through the regulator. In either case the total current from the high-voltage power supply remains almost constant, and this allows almost constant voltage from power supply to picture tube anode.

Because picture tube anode voltage in color receivers is much higher than in monochrome sets, and because the high-voltage supply for color tubes is capable of delivering more current, there is greater danger of painful or dangerous shocks during high-voltage tests and adjustments. The high-voltage probe used during color work must be designed to safely withstand a minimum of 30,000 volts, and should have insulation of such shape and kind on both probe and cable that arc-over or leakage cannot occur while you are proceeding with ordinary caution while making measurements.

Purity Adjustments.—When a color receiver is properly adjusted for purity it will be possible to produce from the red gun alone a raster or field which is pure primary red over the entire viewing screen, without the appearance of blue or green in noticeable amounts. It will be possible also to produce from the blue gun a pure blue field, and from the green gun a pure green field. Purity adjustments are checked by observing the color fields produced by each gun acting alone.

Although color purity is affected chiefly by adjustments of purity magnets or a purity coil, it is affected also by static convergence adjustments and by position of the deflecting yoke along the picture tube neck. Either permanent magnets or an electromagnetic purity coil will produce a magnetic field passing through the picture tube neck and through the path of the three electron beams, to shift the beam position. The direction in which beam position is changed, and how far it is changed, are determined by direction, location, and strength of the magnetic field.

Units which enter into purity adjustments are represented in Fig. 12. When adjustments are made with ring-shaped permanent magnets, direction of the magnetic field through the tube neck is altered by rotating both rings, as a unit, around the neck of the tube. Location of the magnetic field is altered by moving both rings lengthwise of the tube neck. Strength of the field is altered by rotating one ring with respect to the other, to bring the magnetic gaps closer together or farther apart. The field is weakest with gaps opposite each other, and strongest with the gaps together.

When coils are used for purity adjustment, direction of the magnetic field is altered by rotating the coil structure around the

picture tube neck. Location of the field is changed by moving the purity coil structure lengthwise of the tube neck. Strength of the field depends on current in the coil windings, and current is adjusted by means of a potentiometer or rheostat connected between the coils and the low-voltage d-c power circuits.

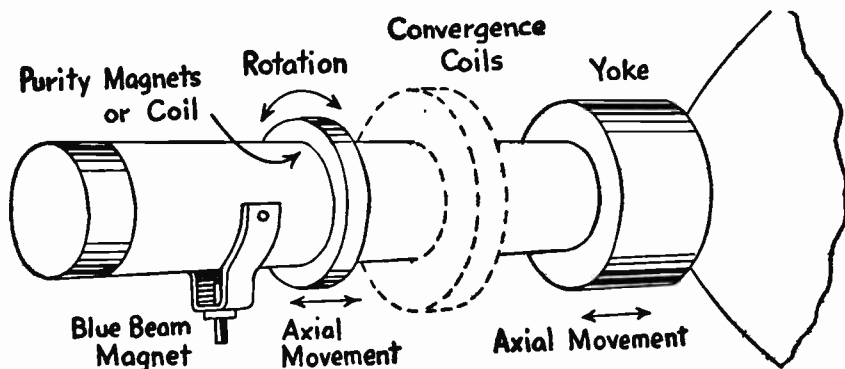

Fig. 12.—Elements on the picture tube neck which are moved during adjustment of static convergence.

A magnetic field which is too strong or which is in the wrong location may cause neck shadows similar to those which appear on monochrome picture tubes when there is wrong adjustment of a focusing coil or of an ion trap magnet. Such shadowing must be avoided.

Color Fields.—If a field of single uniform color can be obtained from each of the three electron guns working alone, these three fields will combine in suitable intensities to cause the visual sensation of white — provided convergence has been made correct over the entire viewing screen. Correct purity adjustments should allow each gun to produce its own color while the other two guns are inactive.

Preliminary settings for color field adjustments are as follows: Contrast is set at minimum, and brightness near maximum. The station selector is set for a channel not used locally; no input signal is needed or desired. If purity is being adjusted for the first time after installation of a picture tube, the deflecting yoke

should be moved well back from the flare of the tube. If purity has been previously adjusted, the yoke will be the last element adjusted.

Two electron guns may be made inactive while the third remains in operation by adjusting screen voltage on the first two guns to zero by means of the color balance controls, while screen grid voltage for the third gun remains maximum or nearly so. Another method consists of grounding the control grids of the two guns which are to be shut off. When employing this latter method the screen grid controls or color balance controls would remain at their original settings, or as for normal reception.

It is helpful to make a preliminary check of static convergence, which is convergence at and near the center of the viewing screen, before making purity adjustments. The manner of adjusting static convergence varies with design of picture tube accessory elements. In some cases this adjustment is made with permanent magnets which are mounted in the cores of convergence coils, in others by shifting three separately mounted permanent magnets called beam positioning magnets, while in still other designs the static convergence adjustment is made by varying the direct current in convergence coils. Detailed procedures will be explained in connection with the subject of convergence adjustments in general.

To commence adjustment of purity the blue and green electron guns are made inactive by grounding their control grids or adjusting their screen grid voltages to zero. The red gun is allowed to operate for checking the red color field.

Strength of the magnetic field from purity magnets or purity coils is made as weak as possible, by setting magnet gaps opposite each other or by reducing coil current to zero. When this has been done, rotation of the magnets or coil structure on the picture tube neck should not affect the raster.

If the field at and around the center of the viewing screen is not of pure primary red, strength of the purity magnetic field should be slightly increased, and the magnets or coil structure rotated to improve the field. Magnetic field strength then may be increased while rotating the magnets or coil structure and moving them lengthwise of the tube neck for the largest red field in the central area of the viewing screen. Procedure is quite similar

to adjustment of an ion trap magnet. Some blue, green, or yellow may remain toward the edges of the viewing screen.

The next step is to move the deflecting yoke slightly forward, or back if not already far from the picture tube flare, until the red field is as pure as it can be made out toward the edges of the viewing screen.

Adjustments of magnetic field strength, magnet or coil position and rotation, and deflecting yoke position should be repeated until the entire raster area is pure primary red in color. Inability to obtain a pure color field may indicate defects in purity magnets or coils, in the deflecting yoke, or even in the electron guns.

Having completed adjustments for the red field, the red electron gun is made inactive while the blue gun is allowed to operate by itself. There should be a pure primary blue field all over the viewing screen. Then, with the green gun operating and the red and blue guns shut off there should be a pure green field over the entire screen.

If blue and green color fields show decided color contamination it may be removed by slight readjustment with either the blue gun or the green gun operating alone. Adjustment procedure is the same as for the red field. If all three color fields cannot be made pure by slight readjustments, it is better to leave the blue or green field somewhat impure than to allow noticeable impurity in the red field.

Static Convergence.—When there is correct static convergence in a three-gun picture tube the three electron beams pass together through the same openings of the shadow mask in a region which includes the center of the viewing screen and an area of moderate size around the center. Then, on this portion of the viewing screen, each beam strikes only phosphor dots of proper color and the three colors may blend to produce white or gray.

Adjustments for static convergence include three permanent magnets, called beam positioning magnets, which are adjustable for polarity by rotating these magnets when mounted in cores of convergence coils, or by turning the magnets end for end when supported by separate brackets. Effective magnetic strength is varied by rotating the core-mounted magnets or by moving the separately supported units toward or away from the picture tube neck.

Each beam positioning magnet is in line with one of the electron guns, and each magnet shifts only the electron beams issuing from its own gun. Static convergence is adjusted also by the blue beam magnet, which may be moved toward or away from the tube neck to alter its effective magnetic strength, or turned end for end to reverse its polarity.

In some color receivers there are static convergence adjustments by means of variable direct currents in each of the three convergence coils. Currents in the red and green coils may be varied for static convergence of red and green, then current in the blue coil is adjusted in connection with positioning of the blue beam magnet to complete static convergence of all three beams.

Static convergence adjustments, also dynamic convergence adjustments for portions of the viewing screen away from the center, are most easily carried out with a dot generator. The principle of this generator is illustrated by Fig. 13. Signals from the generator are equivalent to a luminance signal in their effect on brightness. The signals act on the grid-cathode circuits of the picture tube to control beam intensities.

One voltage from the dot generator is gated so that it appears at regular intervals ten or more times during each horizontal line. Then, along all horizontal lines there appear brief bright sections between dark sections. This signal voltage alone would produce a series of regularly spaced bright vertical bars on the picture tube viewing screen.

Another generator voltage modulated onto the same carrier or video signal is gated to appear only eight or nine times during each vertical deflection period. This voltage by itself would produce a series of bright horizontal bars on the viewing screen. When the two generator signal voltages combine their effects, the viewing screen becomes bright only in small areas where both horizontal and vertical voltages are gated bright. This results in a pattern of regularly spaced bright areas on the viewing screen.

The blue beam lights all the blue phosphor dots in each bright area, while green and red beams similarly light green and red phosphor dots. If the beams are properly converged, each one

lights its color dots in exactly the same bright areas as do the other two beams, and all the pattern areas become white or gray. If the beams are not converged, and fall on different pattern areas, the phosphor dot colors appear separately, or blend only partially, or in pairs of colors.

Procedure for adjusting static convergence varies with receiver design, but is generally as follows: Vertical and horizontal dynamic amplitude and tilt controls are set at minimum. Contrast is adjusted to maximum or nearly so. The brightness control and output from the dot generator are adjusted together so colored or bright pattern areas appear against a dark background. Too much brightness or excessive output from the dot generator will cause defocusing of horizontal trace lines.

Controls for picture tube screen grid voltage or for color balance, also gain controls on demodulators or color amplifiers, are adjusted so that separate color areas are clearly defined and of equal size. Pole pieces of convergence coils must be seated on the picture tube neck.

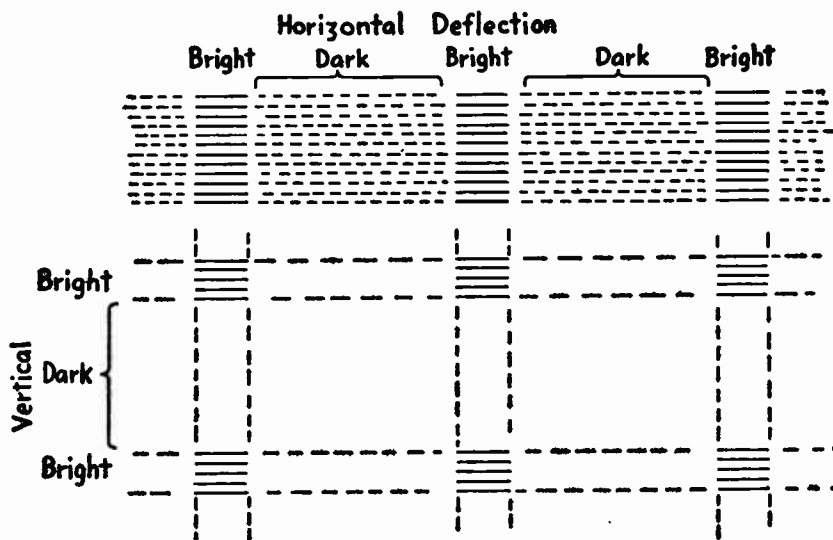

Fig. 13.—How the dot generator produces pattern areas on the picture tube viewing screen.

If primary color areas now show separately at and near the center of the viewing screen, the beam positioning magnets and the blue beam magnet are adjusted to bring the colors together and form areas which are essentially white or gray. Each beam positioning magnet shifts its respective color area, while the blue beam magnet shifts only the blue area. Sometimes it is necessary to make slight readjustments of purity in order to obtain correct static convergence.

Dynamic Convergence Adjustment. Dynamic convergence adjustments bring the three electron beams onto the correct phosphor dots in pattern areas at top, bottom, and sides of the viewing screen. Vertical dynamic adjustments affect areas toward top and bottom. Horizontal dynamic adjustments affect areas at the sides. The objects of dynamic convergence adjustment are to cause all three electron beams to pass through the same shadow mask opening, and to pass at such angles that each beam falls only on phosphor dots of its own color when the beams are deflected away from the central area of the viewing screen.

Dynamic convergence adjustments include vertical and horizontal amplitude controls, vertical and sometimes horizontal tilt controls, and horizontal phasing controls. There is a separate set of controls for each of the three beams. In a general way, the amplitude controls vary the spacing between pattern areas of the three primary colors, the tilt controls allow bringing the three color areas into the form of a triangular pattern with areas equally spaced from one another, while phasing controls shift any one colored area with respect to the other two.

Because dynamic and static convergence controls react on each other it usually is necessary to make slight readjustments of static controls after each adjustment of vertical dynamic controls, then to make horizontal dynamic adjustments and again readjust the static controls. This order of adjustments is repeated until there is correct convergence or white or gray pattern areas over the entire viewing screen.

Exact procedure for dynamic convergence adjustments varies between different receivers. The process may prove difficult unless service instructions issued by the manufacturer are followed to the letter. Following instructions are typical of usual procedures.

Vertical dynamic adjustment is commenced by observing the colored pattern areas extending vertically in a line midway between left and right sides of the viewing screen. There will be convergence at the center of this row, because of preceding static adjustments. But toward top and bottom there will be misconvergence which may be somewhat as shown exaggerated at A of Fig. 14.

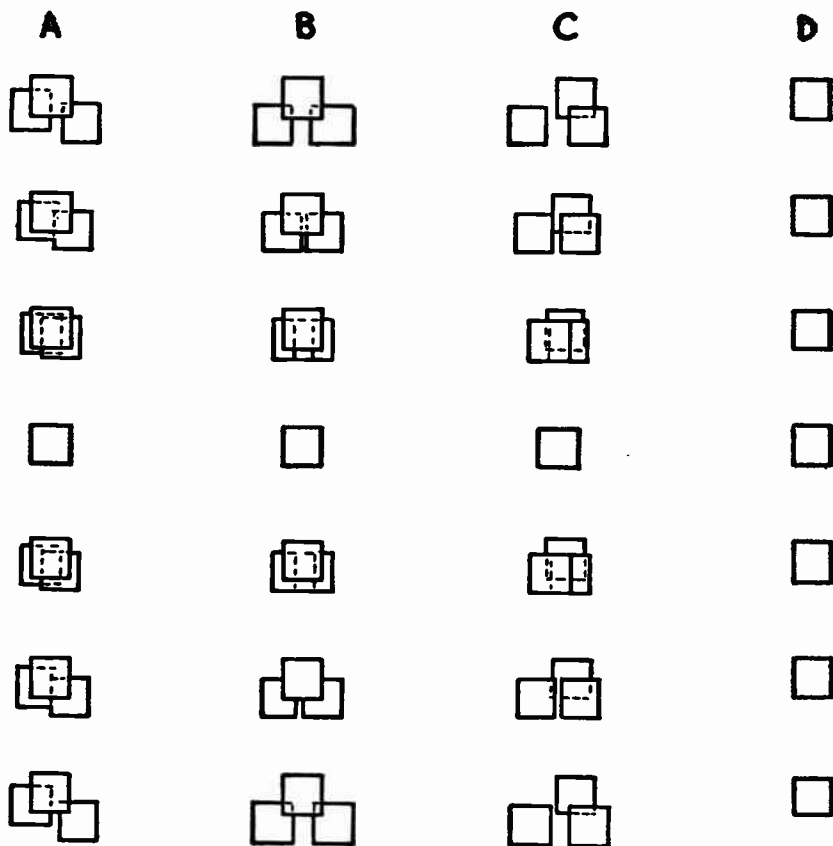

Fig. 14.—Some of the steps in adjustment of vertical dynamic convergence.

Adjustment of red and green tilt controls should bring the red and green pattern areas into a symmetrical triangular formation with the blue areas, as represented at *B*. Adjustment of red and green vertical amplitude controls should space the red and green pattern areas at equal distances from the blue areas, and adjustment of the blue vertical amplitude control should space the blue areas equally from those that are red and green. These adjustments of tilt and amplitude controls probably will upset convergence in the central portion of the viewing screen, and require one or more readjustments of the three beam positioning magnets during the process.

If the blue pattern areas are not aligned symmetrically with red and green areas, as illustrated by diagram *C*, this effect may be corrected by adjustment of the blue tilt control. Final convergence of the colored pattern areas in the vertical row, as at *D*, usually requires some readjustment of the blue beam magnet, which previously was used for static convergence.

After adjusting the vertical dynamic convergence controls there still will be misconvergence at the sides of the viewing screen. This is corrected by the horizontal dynamic controls, which include amplitude and phasing controls for each of the three beams or primary colors. Each phasing control is adjusted, to begin with, while the corresponding amplitude control is at maximum. This phasing adjustment shifts the pattern areas for each primary color as far as possible from those of the other two colors.

Amplitude and phasing controls for each color then are adjusted together to obtain symmetrical triangular patterns. After an adjustment for pattern areas of any one color it usually is necessary to make some readjustment of the beam positioning magnet for that color in order to correct the center convergence. A final adjustment may be made with the blue beam magnet.

Adjustments for convergence, purity, and focus affect one another. When adjustments for any one of these characteristics are altered, effects on the other two should be checked, and corrections made if necessary. Should adjustments for convergence fail to produce satisfactory results, the trouble may be in the convergence coils, the deflecting yoke, or in the picture tube. More probably the trouble is in circuits leading from vertical

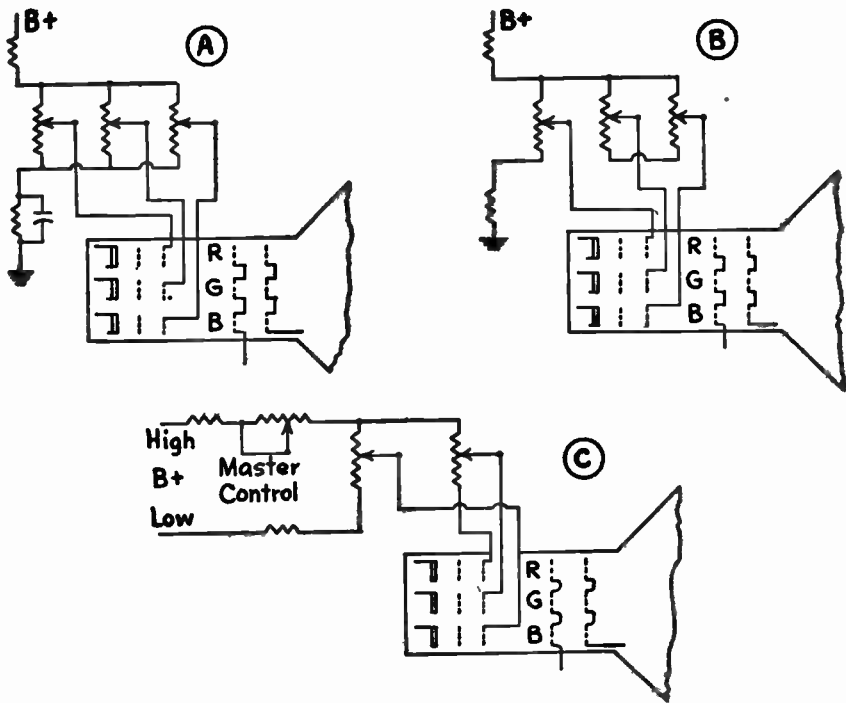

Fig. 15.—Color balance adjustments which vary the voltages on screen grids of the picture tube.

and horizontal sweep circuits to the convergence controls, or in the control units themselves.

Circuit tests are best made with an oscilloscope, commencing with horizontal pulses and vertical sawtooths, and checking from there through to the convergence coil terminals.

Color Balance.—Intensity of light from red, green, and blue phosphors in the color picture tube depends on control grid voltages with reference to the cathodes, and also on screen grid volt-

ages. However, even were these voltages equal in the three electron guns, light emissions still would be unequal because of differences between efficiencies of the phosphors themselves. The red phosphor, especially, would emit less light than the green and blue phosphors. For this reason it is necessary to provide adjustments for screen grid voltages and for grid-cathode voltages or biases in order to balance the color emissions.

The primary object of color balancing is to allow monochrome pictures to appear only in white, black, and shades of gray, with no coloring. When this is accomplished there should be suitable blending of lights from the phosphors for correct hues in color pictures — provided the chrominance and demodulator sections are in good operating condition.

Fig. 15 shows typical control circuits for screen grid voltages. At *A* and *B* there are individual adjustments for red, green, and blue. At *C* there are individual adjustments for green and blue, but not for red. Here there is a master control for varying all three grid voltages simultaneously. Only the master control affects red, for which phosphor efficiency is least, while the green and blue controls are adjusted to bring these color emissions down to the level of red.

In addition to controls for screen grid voltages there will be others for picture tube control grid biases, these really being auxiliary brightness controls, or else for strength of signal voltages to the control grids. These latter controls regulate gains of green and blue color amplifiers, and thereby vary average signal voltage strengths at the green and blue control grids of the picture tube.

At the left in Fig. 16 is shown one method for varying the bias voltages on green and blue control grids. The brightness control varies the positive voltage on the cathodes, while the grid controls apply voltages which are less positive to the control grids, thus making the grids negative in relation to the cathodes.

At the right in Fig. 16 are shown gain controls such as may be used on green and blue color amplifiers. The red color amplifier is allowed to operate at full gain, with gains for green and blue amplifiers adjusted so that these colors match the red.

Color balance controls should be adjusted while receiving a black-and-white transmission, which will provide a range of gray

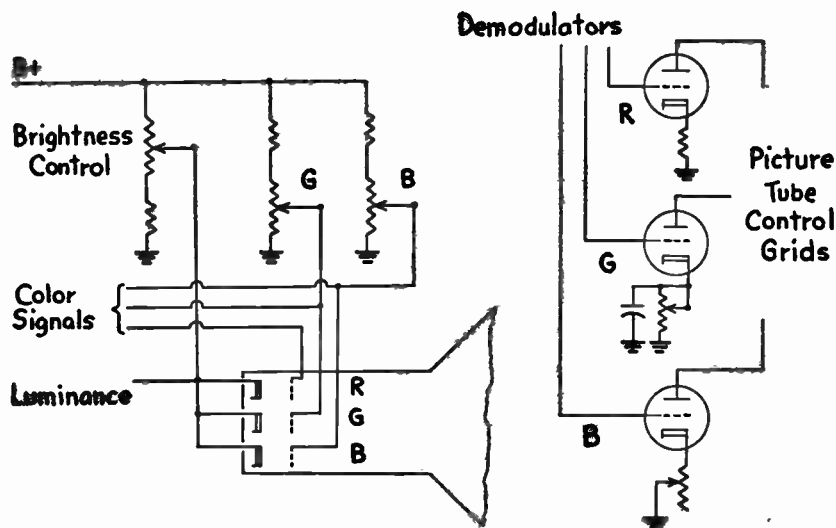

Fig. 16.—Adjustable bias controls for green and blue grids (left) and adjustable gain controls on green and blue color amplifiers (right).

tones from light to dark. Exact adjustment procedures differ with the receiver, but in a general way are as follows. The controls for screen grid voltages are adjusted to remove all coloring in portions of pictures which are medium or dark gray in shade. Then gain controls or grid-cathode bias controls are adjusted to prevent appearance of color in picture highlights, where the tone is white or very light gray.

Light and dark areas of reproduced pictures should be observed with the brightness control alternately high and low, and with the contrast control advanced and retarded. Adjustments are repeated until no coloring appears under any normal operating conditions.

Coloring which does appear during black-and-white transmissions commonly consists of an overcast in some one tint. A blue, green or red tint may indicate that output from the respective

electron gun is too strong, or that outputs from the other two guns are weak. If the overall tint is that of a secondary color (yellow, magenta, or cyan) the complementary primary color (blue, green, or red) usually is too weak, and appropriate controls should be adjusted to strengthen it.

Circuits for retrace blanking often are connected to those for color balancing. Negative blanking pulses may be applied to the screen grids through circuits which control screen grid voltages. Positive blanking pulses may be applied to the cathodes through the brightness control circuit, as is done in many monochrome receivers.

Checking Circuit Troubles.—When any of the various service adjustments fail to correct faulty reproduction of either color or monochrome pictures, the section in trouble often may be identified by noting which colors are either absent or too strong, or by observing the coloring which appears on pictures that should be black and white. This has been explained in detail.

Determining just which circuit elements are causing the trouble requires the same procedures as for trouble shooting in monochrome receivers. This means signal tracing, followed by checks with the vacuum tube voltmeter and ohmmeter, with a capacitor tester, and other commonly employed service instruments. Signal tracing in circuits beyond any of the detectors is most effective when done with the oscilloscope.

Because of very high voltage supplied to the picture tube anode the shock hazard is increased. During final checks of individual circuit components and connections, and of resistances or B-voltages, pictures or patterns ordinarily are not needed. Then the high voltage for the picture tube anode may be shut off by temporarily removing the horizontal output amplifier or possibly the high-voltage rectifiers. In receivers having series heaters this requires jumping the heater terminals of sockets with suitable resistors. Such receivers, or any of the transformerless variety, should be serviced when using an isolation transformer between power line and set.

Color picture tubes are heavier than monochrome types, and must be handled with extra care during removal and replacement. The tube should be lifted only by the large bulb, possibly

with some guidance by holding the neck, but never by the neck alone. The metal rim or flange which forms the high-voltage anode terminal must be carefully protected from contact with anything solid. Supports for color picture tubes are on the large bulb, usually at front and rear. The supports are insulated. The deflecting yoke does not provide neck support, as it does on monochrome picture tubes, because the yoke must be moved during adjustments for purity.

More units must be taken off the neck of a color picture tube than from a monochrome type before the tube is removed from the chassis or cabinet. After removing the socket from the tube base, the blue beam magnet and a purity coil or magnet assembly will slide off over the socket. Ordinarily the convergence coils remain on their support, but must be given enough freedom from the tube neck to allow the neck to slide forward through these coils and also the deflecting yoke. Metal shielding and any insulating sleeves for the bell and flare of the picture tube usually should remain on the tube until after it has been removed from the chassis.

When a color picture tube is replaced after removal it will be necessary to make complete readjustment of purity, static convergence, dynamic convergence, and color balancing controls. This is one reason why the picture tube should remain in place during servicing operations, although great care must be used to protect the tube and those working near it.

LONG DISTANCE FM RECEPTION—AN ANTENNA FOR UHF TV BOOSTERS

This chapter will furnish you with data designed toward helping to strengthen the TV signal in fringe areas. Much of this material was furnished by the Engineering staffs of Sylvania Corporation and the Popular Mechanics magazine.

Long Distance FM Reception.—The allocation of the f-m band in the 100 mc region confines f-m reception essential to line of sight coverage. However, since a sensitive f-m receiver is capable of completely noise-free reception of extremely weak signals, surprising distances are covered regularly in good locations with an adequate f-m receiver. Signals of five to ten micro-volts are

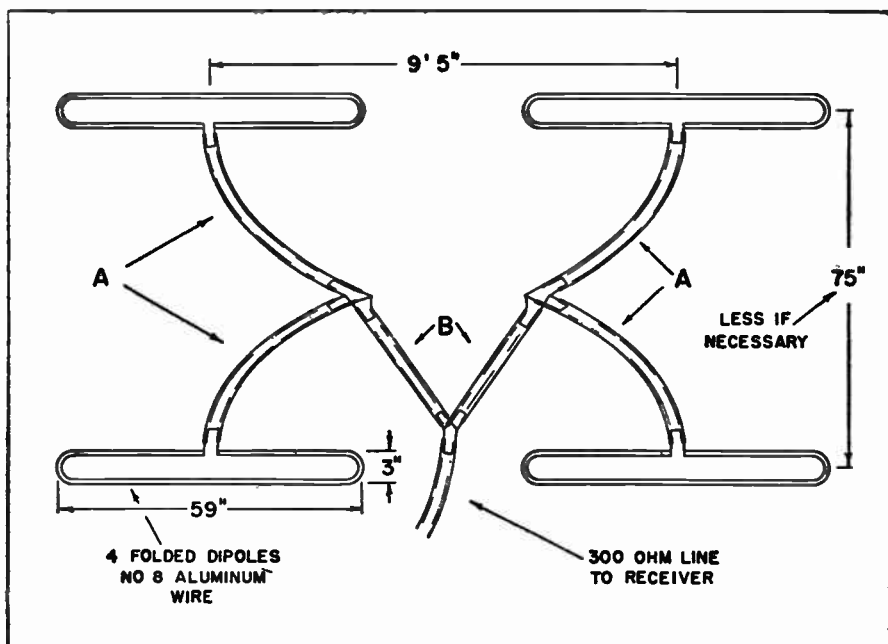

Figure 1. Four Dipole Receiving Array. Elevation View. Orient broadside to the direction of the desired signals. LEGEND: All connections made with 300 ohm twin lead. Leads "A"—Four equal length leads, any convenient length. Leads "B"—Two quarter-wavelength impedance matching sections, 26" long. Phase connections as shown. (Rightside of all dipoles connected together.)

capable of providing 30db quieting on the best receivers, and, if the man made noise level at the receiving location is not several times this value, very good noise free reception is possible on f-m with such minute signals. There are still many areas in the country in which the standard band broadcast reception leaves much to be desired during the summer months. In such areas it is profitable to exploit the possibilities of f-m reception.

Few of us are fortunate enough to live on the top of a mountain, therefore, let us consider f-m reception in a valley or plains area and how we can improve it. In a hilly or mountainous terrain f-m reception in a valley may be poor simply due to the lack of adequate signal strength. Occasionally, trouble is also encountered from multipath reception which can be recognized by high distortion of the audio at certain levels of modulation, although the average signal level appears quite adequate. One explanation for this effect is that the signal is being received over two or more paths; and at certain frequencies corresponding to particular modulation levels, the signals arrive with such phase relationship as to cancel the other.

This condition may be overcome by either of two opposite modes of attack. The first method is to increase the directivity of the antenna by adding reflectors or directors and orienting the antenna to receive the signal from just one source. The disadvantage of this is that it is usually necessary to add a rotator to the antenna.

In heavily wooded country the reflection conditions change markedly with the seasons or with the presence or absence of leaves on the trees. An alternate method of overcoming multipath reception is to interconnect several dipoles whose physical dispersion is such as to prevent complete cancellation of signals in all the dipoles at any one time. This method is particularly effective where the stations lie in opposite directions. A method of connecting four folded dipoles together is shown in Fig. 1. This array is matched to a 300 ohm line by means of sections of 300 ohm twin lead of the proper length. It can be inexpensively constructed from aluminum clothesline and mounted in the attic of a house. It is bi-directional and has a theoretical gain of 6 to 7.9 db.

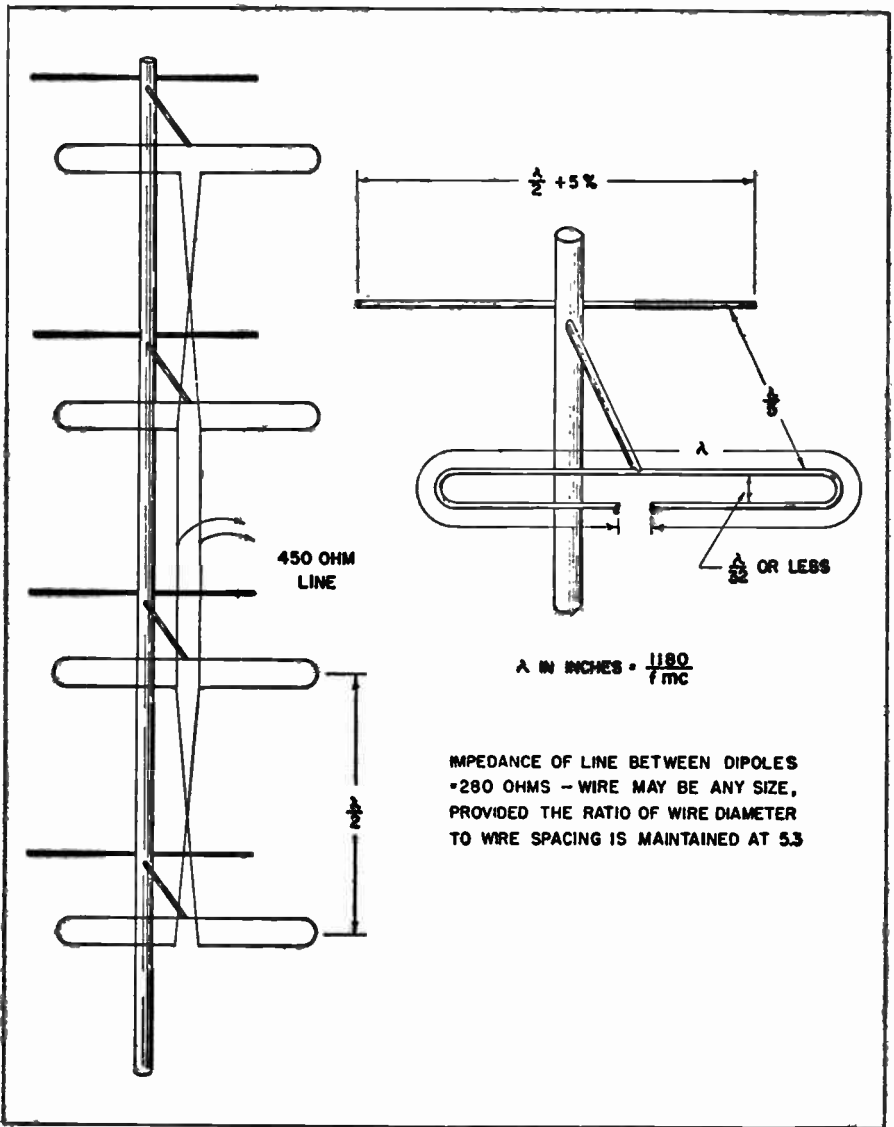

Figure 1a. Antenna, showing design formulae for various spacings.

If signals available are not strong enough to provide limiting in the f-m receiver it is often possible to increase the sensitivity of the receiver by the addition of a good wide band untuned booster in front of the receiver.

Antenna for UHF TV Reception.—The performance of a television receiver depends to a great extent on the antenna installation. This is particularly true at uhf where the increase in transmission line and propagation losses is such that, except in local areas, some sort of high gain antenna is mandatory for satisfactory reception. Fortunately, because of the high frequency involved, high gain antennae may be produced which are not physically clumsy.

The Antenna.—The antenna to be described here consists of four folded dipoles with reflectors, stacked vertically. The construction is not difficult and excellent results are obtained. A drawing of the antenna is shown in Fig. 1a together with the design formulae for the various spacings. Models have been built using both copper and aluminum tubing. Copper offers some advantages because it may be joined with solder; however, it is considerably heavier. Various types of aluminum solder are available but they are not recommended because of their low resistance to atmospheric corrosion and because they are somewhat difficult to use. The use of bolts or rivets is preferable in aluminum fabrication for outdoor installations.

Performance.—The forward gain of an antenna of this type, designed for a frequency of 525 mc, was measured at 11.7 db with respect to a single folded dipole. Horizontal and vertical radiation patterns are given in Figures 2 and 2A. Although the antenna is cut for a particular channel, satisfactory results may be expected over a range of several channels either side of the design frequency.

The Transmission Line.—The antenna is designed to feed commercially available 450 ohm open wire transmission line. This choice was made because of the considerably higher attenuation of coaxial cable and 300 ohm twin lead lines. Table I gives typical values of the db loss per 100 feet for the various types of line. Obviously, one should employ a transmission line with the lowest possible attenuation. Otherwise, it would be quite possible to incur such a loss in the transmission line that the gain of the

antenna would be completely nullified. Such a condition will result from the use of 360 feet of dry or 59 feet of wet 300 ohm twin lead line; 390 feet of dry or 115 feet of wet tubular 300 ohm line; 120 feet of RG-59U; 230 feet of RG-11U, or 1400 feet of 450 ohm open wire line, with the 525 mc antenna described.

At the receiver end of the line, one of two things must be done, depending on whether the receiver is designed to match 300 ohm line or 50 or 75 ohm coaxial cable. In the first case, the line may be matched to the receiver with a section of line $\frac{1}{4}$ wave length long at the antenna design frequency and having a characteristic impedance of 368 ohms. Alternately, a tapered line may be used.

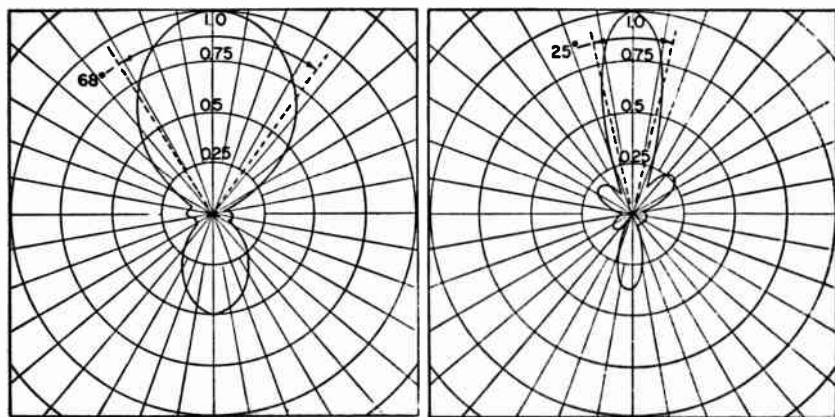

Figs. 2 & 2A. Horizontal and vertical radiation patterns.

This consists of a section of transmission line that has an impedance of 300 ohms at the receiver and changes gradually to 450 ohms over a distance of at least 2 wavelengths.

If the receiver is designed for a coaxial line input, a balun, or balanced-to-unbalanced transformer must be used.

This antenna is but one of several types suitable for use at uhf. However, the construction is not difficult, the measured performance has shown excellent agreement with the theoretical value, and the gain is adequate for all but the most difficult locations.

UHF—TV BOOSTERS

TV Boosters.—There are many towns in the U.S.A. where television is received from a station located 60 to 125 miles away. While there have been instances where a TV program has been seen and heard as far away as 900 miles it is generally accepted that 70 miles is about as far as a TV program can be seen without using special devices of strengthening the signal.

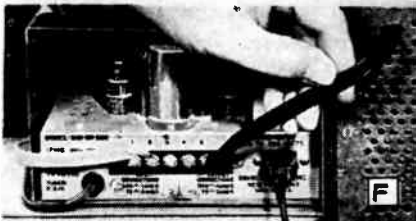
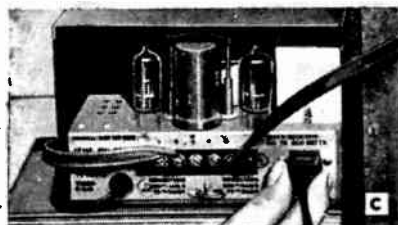
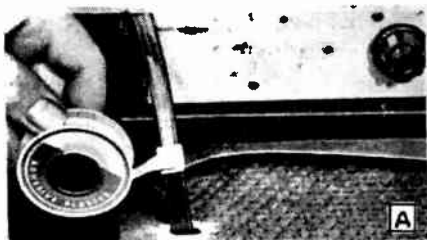

There are basically two ways to increase a TV signal—(a) by increasing the height of the antenna and (b) by using what is known as TV Boosters. The installation of a TV booster may increase the signal 5 to 10 times. It is a comparatively simple job to install a TV booster as the following article will indicate.

While manufacturers instructions should be followed for best results we recommend these suggestions. To begin with, a TV Booster is a self powered r-f amplifier unit connected between the antenna and the receiver. It is tuned to receive any of the 12 television channels from channel 2 to 13.

There are many types of TV boosters but most employ basically the same general wiring circuit. A typical booster is illustrated in these photos. In some TV receivers the twin lead antenna line is permanently attached and extends a few inches outside the back cover.

Care should be exercised when making connections with twin lead transmission line. In our sample installation shown in the photos disconnect the set from the power line outlet. Then remove the back cover and tape the line just inside the cover as illustrated in photo "A." Since the terminals on the booster are usually close together (see photo "B") make sure that the fine strands of wire are not shorting them. Use soldering lugs in the antenna twin leads. The set power plug that goes in the receptacle on the rear of this booster should make good contact (see photo C). The TV set switch operates both units.

Some boosters employ more than one tube. One operates on the low bands and the other on the high. When these tubes are the same type an improvement may often be had by switching the tubes from one circuit to the other, as indicated in photo "D." A slight pressure on the top of the booster control knob while band changing (see photo "E") will help you make the adjustment accurately. The twin lead from the receiver that connects to the output terminals of the booster should be as short as possible as indicated in photo "F."

Servicemen in fringe areas will find it profitable to get as much data as possible from manufacturers of TV Boosters. A list of the leading companies making boosters can be found in any issues of leading radio-TV magazines.

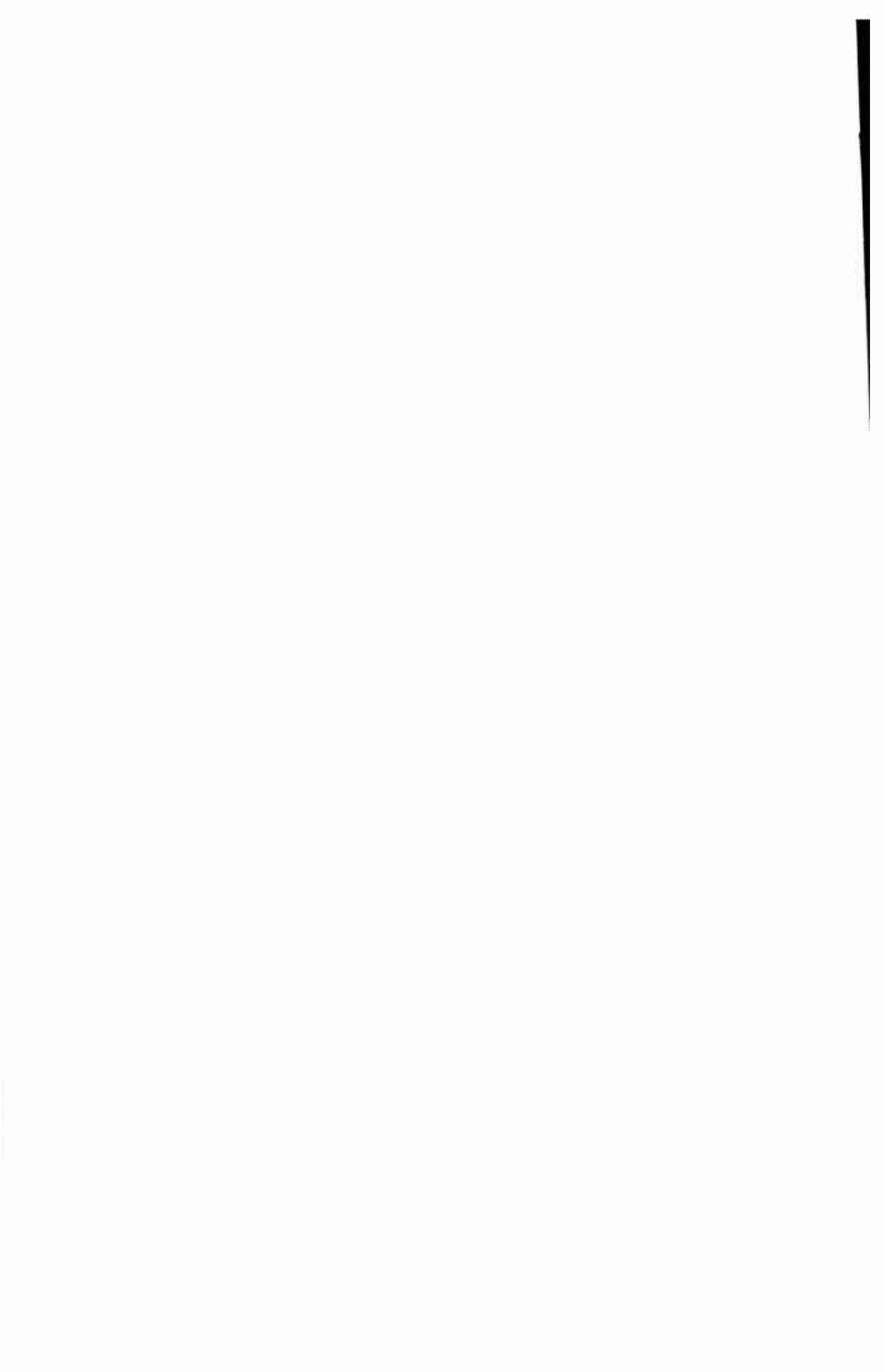

INDEX

A

- Accompanying sound frequency, 97
- Adjacent sound frequency, 97
video frequency, 97
- Adjustments, see names of parts or functions.
- Aerials, see Antennas
- Alignment
- antenna stage, 172-178
 - traps, 179
 - electronic voltmeter for, 49
 - connections to, 121-122
 - fixed bias for, 95, 111
 - generator connections for, 109
 - intercarrier sound, 143-160
 - input stage, 172-178
 - used for, 107
 - oscillator removed during, 122
 - oscilloscope, 35-39
 - connections to, 121-122
 - overall check, tuner and video i-f, 189-192
 - picture tube removed during, 110
 - preliminary steps for, 109-113
 - ratio detector, oscilloscope, 154-160
 - voltmeter, 149-152
 - rectifier removed during, 110
- Alignment, r-f
- amplifier, 172-178
 - oscillator, 163
 - intercarrier sound, 186-189
 - oscilloscope for, 185-189
 - using sound i-f for, 182-186
 - voltmeter for, 183
 - trap, 179
- Alignment, shields removed for, 49
- Alignment, sound
- chapter relating to, 143-160
 - discriminator, oscilloscope for, 154-160
 - voltmeter for, 149-152
 - interstage couplers, oscilloscope, 152-154
 - voltmeter for, 148-149
 - preliminary steps, 147
 - takeoff, oscilloscope for, 152-154
 - voltmeter for, 148-149
- Alignment, stage by stage, 136-138
- trap, 113-118
 - antenna or r-f, 179
 - sound bars used for, 118
 - tuner, 161-192
 - inductor types for, 170
 - general instructions for, 161-170
 - overall check, with video i-f, 189-192
 - tuning wand for, 170
- Alignment, video i-f
- chapter relating to, 107-141
 - double peaked stage, 131-136
 - instruments for, 120
 - connections to, 123-124
 - intercarrier sound, 139-141
 - overall check, with tuner, 189-192
 - oscillator removed during, 122
 - separate stages, 136-138
 - single peaked stages, 127-131
 - stage by stage, 124-125
 - stagger tuned stages, 127-131
- Amplifiers
- audio, high voltage for, 323
 - voltage regulation from, 325-326
 - d-c, horizontal afc, 254
 - deflection, see *Sweep amplifiers*.
 - horizontal, magnetic, 270-278
 - plate voltage at, 278
 - magnetic deflection, 267-272
 - r-i, see *Tuners*.
 - Amplifiers—(Cont.)
 - sweep, see *Sweep amplifiers*.
 - sync, 221
 - vertical, electrostatic, 263
 - magnetic, 267-270
 - video, 202-203
 - waveform observations on, 201
 - video i-f, 83-106
 - couplings for, 84-85
 - oscillation in, 141
- Antennas, 327-346
- attenuator pad for, 172
 - coupler, alignment of, 173-178
 - dipole, 328-335
 - directional, 329-332
 - director for, 332
 - erection of, 345-346
 - folded dipole, 328
 - impedance of, 336
 - matching to line, 336, 340, 341
 - lengths for, 329
 - location of, 342-344
 - matching stubs for, 341
 - orientation of, 342-344
 - position of, 342-344
 - reflector for, 330-332
 - stacked, 335
 - traps on, 102-104
 - alignment of, 179
 - two-band, 332-335
- Associated sound frequency, 97
- Attenuation, receiver, 85-87
- Attenuator pad, 172
- Audio, see *Sound*.
- Automatic
- brightness control, 214
 - gain control, 91-96
 - circuits for, 94
 - fixed bias during alignment, 95, 111, 143
 - voltage for, 93
 - sweep frequency control, see *Horizontal afc*.
- ## B
- Band width, broadening of, 85
- r-f, adjustment of, 173-174
- Bars, sound, appearance of, 117
- trap alignment with, 118
- Beam cutoff, power supply action for, 318
- Bench, test, grounding of, 41
- Beat, intercarrier, traps for, 104-106, 203
- Bias, fixed, alignment use of, 95, 111, 143
- picture tube, effects of, 207-211
- Black level, 13
- Blanking level, 13
- Blocking oscillator
- action of, 227-231
 - discharge tube for, 231
 - sync polarity for, 236
 - waveforms from, 229
- Booster, voltage, damper as, 281
- Brightness, anode voltage effect on, 266
- control, action of, 205
 - automatic, 214
 - drive control effect on, 275, 277
- Brilliance, see *Brightness*.
- Broad band response, securing, 85
- Buzz, intercarrier sound, 140, 160
- B-voltage supply, see *Power supplies*.C

Capacitance, stray, 58

Carrier, frequencies for video and sound, 170
location in band or channel, 17

Cathode input, picture tube, 14

Center frequency, sweep generator, 30

Centering

- controls for, 268, 301-304
- electrostatic, 302
- focus coil for, 304
- magnetic, electrical method, 303
- focus coil for, 304

Channels, frequencies in, 78
selectors for, see *Tuners*.
very-high frequency, 16-18
wavelengths of, 329

Clipper, sync, 221

Coils, deflection, 298
hairpin, adjustment of, 170
tuner, types of, 170

Color Television, 347-430

Combination wave, sawtooth and pulse, 230-237

Component, d-c, signal, 211-213

Composite signal, 11-15

Continuous tuners, 55-56, 167-168

Contrast control, checking action of, 303

Controls

- automatic gain, 91-96
 - circuits for, 94
 - fixed bias alignment, 95, 111, 148
 - voltage for, 93
- brightness, action of, 205
 - automatic, 214
- centering, 301-304
 - electrostatic, 302
 - focus coil used for, 304
 - magnetic, electrical method, 303
 - vertical, 268
- contrast, checking action of, 202
- drive, adjustment of, 274-275
 - capacitor type, 274-277
 - picture tube anode voltage affected by, 276
 - resistance type, 272-274
 - waveforms of, 273, 276, 277
- fine tuning, 60
- focusing, 299-301
 - adjustment of, 301
- height, 238, 269
 - anode voltage effect on, 293
- hold, 238-242
 - horizontal, adjustment of, 240-242
 - a/c, see *Horizontal a/c*.
 - lock-in for, 241
 - pull-in for, 241
 - vertical, adjustment of, 241-242
 - horizontal a/c, see *Horizontal a/c*.
 - size, 238
 - output transformer type, 273
- linearity, 282-283
 - amplifier bias for, 283-285
 - choke used for, 285
 - damper type, 285-287

Controls—(Cont.)

- inductor for, 285
- vertical, 284-285
- peaking, 372-374
- size, 238
 - horizontal, 272, 278
 - vertical, 269, 293
- sweep frequency, automatic, see *Horizontal a/c*.

vertical size, 269, 293
width, 238, 272, 278

Corona discharge, high-voltage, 319

Couplers, antenna, alignment of, 172-173

- double-peaked, 87-89
- single-peaked, 87-89

Coupling, effect on resonance peaks, 130
generator to receiver, 42-43, 109
interstage, 125-126
video i-f amplifier, 84-85

Crossover, S-curve, 157

Crystal detector, video, 197

Curve, S, crossover of, 157
oscilloscope, obtained on, 156-158
production of, 155-158
requirements for, 158

D

Damper, action of, 279-282

- booster action of, 281
- heater supply for, 321
- linearity control on, 285-287
- triode tube for, 287
- waveform from, 281

D-c amplifier, horizontal a/c, 214
component of signal, 211-213

D-c restorer

- action of, 213-216
- diode for, 214-216
- picture tube cathode circuit, 214
- sync takeoff from, 218
- test of, 216
- triode for, 216
- video amplifier type of, 213
- waveforms from, 221

Definition, tube size effect on, 19

Deflection amplifiers

- action of, 263-279
- electrostatic, 263-267
 - horizontal, magnetic, 270-278
 - linearity control on, 283-285
 - plate voltage at, 278
- magnetic, 267-272
 - vertical, electrostatic, 263
 - magnetic, 267-270
 - waveforms from, 269-270

Deflection coils, 298

- waveforms from, 298
- current, anode voltage and, 298

Deflection, electrostatic

- amplifiers for, 263-267
 - push-pull, 263-265
- oscillator direct connected for, 266
- sawtooth inversion for, 265
- single amplifier for, 265
- waveforms for, 266

Deflection, magnetic

- amplifiers for, 267-272
 - horizontal, 270-278
 - coils for, 298
- sawtooth and square pulse for, 266-287

Deflection voltage and anode voltage, 298
yoke, rotating picture with, 299

Demodulator, sound, see *Sound discriminator* and *Ratio detector*.

Detector, crystal, 197

- phase, 250-256
- adjustment of, 252

Detector, crystal—(Cont.)
d-c amplifier with, 284
probe, 26-26

Detector, ratio
action of, 79-82
alignment, oscilloscope, 154-160
principle of, 147
voltmeter for, 149-152
circuit of, 146
instrument connection to, 167
noise rejection in, 80-81
output connection to, 147
S-curve of, 155-158

Detector, video
action of, 193-198
circuits for, 196
crystal type, 197
polarity of signal from, 194, 196
test points for, 196, 197
waveform at output of, 199-201

Deviation, television sound, 148

Dipole antennas, 328-335
folded, 328
half-wave, 328
impedance of, 336
stacked, 335

Directional antennas, 329-332
Director, antenna, 332

Discharge tube, blocking oscillator, 231

Discriminator, horizontal afc, 245-249
adjustment of, 249-250

Discriminator, sound
action of, 79
alignment, oscilloscope, 154-160
principle of, 146
voltmeter for, 149-152
circuit of, 144-160
instrument connection to, 165
output connection to, 145
S-curve from, 155-158

Distance, transmission, 327

Divider, voltage, electronic voltmeter, 47-69

Double-peaked response, coupling effect on, 132
transformer, response of, 136
tuning, 87-89
video i-f alignment, 131-136

Double-superheterodyne converter, 306

Douhler, voltage, 313-315

Dressing of conductors, 49

Drift, frequency, r-f oscillator, 56-60

Drive control
adjustment of, 274-275
capacitor type, 274-277
picture tube voltage affected by, 276
resistance type, 272-274
waveforms from, 278, 276, 277

E

Electronic voltmeter
action of, 39-41
alignment by means of, 49
connections for, 121-122
detector probe for, 25-26
filter probe for, 36-48
r-f oscillator alignment with, 133, 136
sound alignment with, 148-152
video detector for, 47-48

Electrostatic centering, 302

Electrostatic deflection amplifiers for, 263-267
push-pull, 263-265
oscillator direct connected for, 266
sawtooth inversion for, 265
single amplifier for, 265
waveforms for, 266

Electrostatic picture tube
basing connections for, 289-290
power supply for, 44
rotation of picture with, 290
voltage on, 290

Equalizing pulses, 11

F

Feedback, video i-f amplifier, 141

Fidelity, color, 379

Fields, color, 354-357

oscilloscope frequency for, 200

Filter, color, 349-351

horizontal afc, 248

sync, 223-226

integrating, 224

probe, 36-37

sync separation, 223-226

vertical sync, 223-226

Fine tuning control, 60

Fixed bias, alignment, 95, 111, 148

Flashover, high-voltage, 319

Flyback power supply, 43, 309-315

Focusing

coil, centering with, 304

position of, 301

control, 299-301

control, 299-301

adjustment of, 301

electrostatic, 300

magnetic, 300

Folded dipole antenna, 328

impedance of, 336

Foster-Seeley discriminator, 79

Frames

oscilloscope frequency for, 200

Free running frequency, 239

Frequencies

accompanying sound, 97

adjacent sound and video, 97

associated sound, 97

carrier, video and sound, 173

center, sweep generator, 39

channel, very-high, 173

drift of, r-f oscillator, 58-60

free running, 239

image, interference from, 103

intermediate, oscillator effect on, 76, 103

sound, amplifier response, 75

video i-f, 37

video-sound relations, 71

responses at, see Response, frequencies.

r-f oscillator, effects of, 180

television, 15-16

Fringing, color, 380

Front end, see Tuners.

G

Gain control, automatic

action of, 9-96

circuits for, 94

fixed bias during alignment, 95, 111, 148

voltage for, 93

Gain, oscilloscope measurement of, 201

Generators, sweep, see Sweep oscillators.

Generators, test

attenuator pad for, 172

impedance matching for, 171

marker type, see Marker generator.

sweep type, see Sweep generator.

Germanium crystal rectifier, 197

Grid input, picture tube, 15

Grounding of instruments, 42

H

Hairpin inductors, adjustment of, 170

Half-wave dipole, 328

lengths for, 329

Heaters, series, polarity check of, 323
Height, anode voltage effect on, 303
controls for, 238, 269
High-voltage power supplies, 43-44, 307-309
Hold controls
action of, 238-242
horizontal, adjustment of, 240, 241-242
afc, see *Horizontal afc*.
lock-in and pull-in of, 241
vertical adjustment of, 241-242
Horizontal afc (automatic frequency control)
chapter relating to, 243-262
d-c amplifier and phase detector, 254
diode for oscillator bias, 260-262
discriminator for, 245-249
adjustment of, 249-250
filter for, 248
hold control action on, 252-254
multivibrator and phase detector, 254-260
adjustment of, 256
noise filter for, 248
oscillator bias type of, 256-260
adjustment of, 258-260
phase detector for, 250-256
adjustment of, 252
reactance tube for, 243-245
triode oscillator bias for, 256-260
waveforms from, 253, 258
Horizontal amplifier, magnetic, 270-279
linearity control on, 283-285
plate voltage at, 278
drive control, see *Drive control*.
filter, sync, 223-226
hold controls, 238-242
adjustment of, 240, 241-242
linearity controls, 282-288
size controls, 238
drive control effect on, 272
output transformer type, 278
sweep, automatic frequency control type, see *Horizontal afc*.
sync pulse separator, 223-226
waveforms for, 219-221, 225

I

I-f amplifier, sound, 75
video, see *Video i-f amplifier*.
Image frequency interference, 103
Impedances
antenna, 336
matching, antenna-line, 336, 340, 341
generator to receiver, 171
stubs for, 341
transmission line, 336-338
Inductors, hairpin, adjustment of, 170
tuner, types of, 170
Inductance, 168
Input, antenna, alignment of, 172-173
Inputuner, 168
Instruments, see also individual names
grounding of, 42
high-voltage connection of, 45
setups for, 41-43
Integrating filter, 224
Intensity, see *Brightness*.
Intercarrier beat, traps for, 104-106, 303
interference, 104
Intercarrier sound
action of, 73-78
alignment for, 143-160
buzz with, 140, 160
oscillator tuning effect on, 76
overall video response for, 140
r-f oscillator alignment for, 186-190
trap for shelf on response, 140
video i-f alignment for, 139-141
Interchannel interference, 104

Interferences
high-frequency pattern showing, 304
image frequency, 103
intercarrier, 104
traps for, see *Traps*.
Interlacing, defective, 270
Interlock, power supply, 45
Intermediate frequencies
oscillator effect on, 76, 180
sound, amplifier response, 75
video i-f, 87
video-sound relations, 71
Interstage couplers, 125-126
Ion trap, 304-306
adjustment of, 306
Isolating transformer, need for, 42

L

Levels, signal, 18
Limiters, sync, 221
Lines, oscilloscope frequency scan, 309
transmission, 337-342
impedance of, 336-338
losses in, 344
matching impedance of, 336, 340, 341
Linearity
controls for, 282, 288
amplifier bias for, 238-239
choke for, 285
damper type of, 285-287
inductor for, 285
vertical, 284-285
drive control effect on, 278-274, 275, 277
height control effect on, 282
troubles with, 287
Load, video detector, test points on, 194, 199
Local oscillator, see *R-f oscillator*.
Low-voltage B-power supply, 320-322

M

Magnetic centering, electrical method, 300
deflection amplifiers, 267-272
horizontal, 270-278
coils, 298
sawtooth and square pulse scan, 236-237
focusing, 300
picture tubes, 291-292
basings connections of, 298
power supply, 4, 43
Marker generators
action of, 31-36
attenuator pad for, 172
calibration of, 34
connections for, 32, 109
coupling from, 43
frequencies required from, 34
impedance matching for, 171
markers produced by, 34
output required from, 35
use of, 34
Markers, identifying at trap frequencies, 119
production of, 33-34
Mask, picture tube, 293-295
Matching, generator impedance, 171
stubs, at receiver, 341
transmission line, 336, 340, 341
Measurements, voltage, 43-49
Mixer, see *Tuners*.
r-f oscillator coupling to, 58
Multiplier, voltage, 313-315
voltmeter type of, 46-48
Multivibrator oscillator
action of, 232-236
horizontal afc, adjustment of, 266
phase detector with, 254-256
sync polarity for, 236
waveforms from, 235

N

- Negative pulse, sawtooth with, 236-237, 271
- feedback producing, 276-277
- Noise rejection, ratio detector, 80-81

O

- Orientation, antenna, 342-344
- Oscillation, video i-f amplifier, 141
- Oscillator, blocking
 - action of, 227-231
 - discharge tube for, 231
 - sync polarity for, 236
 - waveforms from, 229
- Oscillator, free running frequency, 239
 - local, see *Oscillator, r-f*
 - multivibrator, see *Multivibrator*
 - power supply, see *Rf power supply*
- Oscillator, r-f (See also *Tuner*)
 - alignment of, 163
 - intercarrier sound, 186-189
 - oscilloscope for, 185-189
 - sound i-f used for, 182-186
 - voltmeter for, 183
 - disable for sound alignment, 148
 - frequency drift in, 58-60
 - effects of, 180-182
 - operating, 57
 - intermediate frequencies affected by, 76
 - mixer coupling from, 58
 - switching for, 63-64
 - types of, 58
- Oscillator, sweep
 - action of, 227-242
 - blocking type, 227-231
 - discharge tube for, 231
 - sync polarity for, 236
 - waveforms from, 229
- horizontal afc, see *Horizontal afc*
- multivibrator, 232-236
 - horizontal afc, adjustment of, 236
 - phase detector with, 254-256
 - sync polarity for, 236
 - waveforms from, 235
- Oscilloscope (See also *Response, frequency* and *Waveforms*)
 - action of, 35-39
 - alignment connections for, 121-122, 266
 - detector probe for, 25-26
 - filter probe for, 36-37
 - frequency response required, 36
 - gain measurement with, 201
 - phasing control for, 28-29
 - r-f alignment with, 174-178
 - r-f oscillator alignment with, 186-199
 - S-curves formed on, 155-158
 - sensitivity required in, 36
 - sound alignment with, 152-160
 - sweep synchronizer for, 28-29
 - synchronizing for waveforms, 200
 - traces, inversion and reversal of, 37
 - video amplifier output on, 201
 - detector output on, 199-201
 - test points for, 196-197
 - voltage measurement with, 38-39
 - waveform observation with, 198-202, 219-221
- Overall alignment tests, 189-192
 - tuner adjustments, 166-168
 - video i-f response, 187-189

P

- Pads, attenuator, 172
 - impedance matching, 171
- Peaking, control for, resistance type, 272-274
 - coupling effect on, 126, 132
 - response, regeneration causing, 141

- Peak-to-peak voltages, 39
 - Phase detector, 250-256
 - adjustment of, 252
 - d-c amplifier with, 254
 - Phasing control, sweep, 28-30
 - Picture area, 293-295
 - Picture tubes
 - anode voltage on, 293
 - drive control effect on, 276
 - bias, effects of, 207-211
 - cathode input to, 14, 206-207
 - signal polarity for, 194, 198
 - d-c restoration at, 214-216
 - electrostatic, basing connections, 296-299
 - power supply for, 44
 - rotating picture with, 299
 - voltages on, 290
 - grid input to, 15, 205
 - signal polarity for, 194, 196
 - handling of, 44, 295
 - input circuits for, 205-216
 - magnetic, 291-292
 - basing connections for, 292
 - power supply for, 43
 - masks for, 298-299
 - power supply for, 307-326
 - removal and replacement of, 296-298
 - rotating picture with, 299
 - service on, 289-306
 - signal polarity to, 194, 198
- Pips, marker, identifying at trap frequencies, 119
 - production of, 33-34
- Plate-cathode series power supply circuits, 322-326
- Plateau, intercarrier response, 140
- Polarity, picture tube input, 194, 198
 - sync, to oscillator, 236
 - video detector output, 194, 198
- Potter sweep circuit, 232
- Power rectifiers, series, 307-308
- Power supplies
 - action of, 307-326
 - capacitor discharge to, 44
 - corona in, 319
 - electrostatic picture tube, 44
 - filter capacitance for, 310
 - flashover in, 319
 - flyback type, 43, 309-315
 - beam cutoff with, 313
 - high-voltage, 43-44, 307-322
 - rectifiers for, 313-319
 - interlock for, 45
 - low-voltage B-, 320-322
 - series plate-cathode, 322-326
 - magnetic picture tube, 43, 309-316
 - r-f type, 315-318
 - feedback for, 316-317
 - adjustment of, 317
 - voltage adjustment of, 318
 - series plate circuits in, 322-326
 - shielding of, 313, 318
 - sixty-cycle type, 309
 - voltage doubler for, 313-315
- Probe, detector, 25-26
 - filter, 36-37
- Pulses, equalizing, 11
 - sync, 11
- Push-pull amplifier, electrostatic deflection, 263-265

R

- Raster, characteristics of, 7
 - meaning of, 3
- Ratio detector
 - action of, 79-82
 - alignment, oscilloscope, 154-160
 - principle of, 147
 - voltmeter, 149-153

- Ratio detector**—(Cont.)
 circuit of, 146
 instrument connections to, 147
 noise rejection in, 80-81
 output connection to, 147
 S-curve of, 155-158
- Reactance tube, horizontal afc, 243-245**
- Receiver attenuation, 85-87**
 sections of, 3
- Rectifier, high-voltage, 318-319**
 filament temperature test, 319
 power, series connections, 307-308
- Reflector, antenna, 330-332**
- Regeneration, video i-f amplifier, 141**
- Regulation, voltage, audio amplifier for, 325-326**
- Reinsertion, d-c, see Restoration, d-c.**
- Resonant lines, 384-385**
- response, frequency**
 broad band, securing, 85
 coupling effect on, 132
 inversion and reversal of traces, 87
 peaks due to regeneration, 141
 phasing of curves for, 28-29
 r-f, 74
 band width adjustment, 173-174
 sound i-f amplifier, 75
 stagger tuning, 89
 trap effect on, 118
 video i-f, 74, 85-87
 alignment changes of, 131, 135
 couplers, 137
 intercarrier sound, 75, 139-141
 intermediate stages, 137
 overall, 137-139
 peaks in, 141
 requirements for, 118-119
 stages, 127, 129
 trap effect on, 97, 118
- Restoration, d-c**
 action of, 213-216
 diode for, 214-216
 picture tube cathode circuit, 214
 sync takeoff from, 218
 test of, 216
 triode for, 216
 video amplifier method, 213
 waveforms from, 221
- R-f alignment, 172-173**
 amplifier, see *Tuners*.
 band width adjustment, 173-174
- R-f oscillators (see also Tuners)**
 action of, 56-60
 alignment of, 163
 intercarrier sound, 186-189
 oscilloscope for, 185-189
 sound i-f used for, 182-186
 voltmeter for, 183
 disabled for sound alignment, 143
 frequency drift in, 58-60
 frequencies for, 57
 frequency effects of, 180-182
 intermediate frequencies affected by, 76
 mixer coupling from, 58
 rotary switch for, 63-64
 types of, 58
- R-f power supply, 315-318**
 feedback for, 316, 317
 adjustment of, 317
 voltage adjustment of, 318
 response curve, 74
 trap, 102-103
 alignment of, 179
- Rotary switch tuners, 162-165**
 turret tuners, 165-167
- Sawtooth voltages**
 inversion, electrostatic deflection, 265
 negative pulse formed on, 271, 276-277
 production of, 230-231
 square pulse with, 236-237
 waveforms from, 229
- Screen, masks for, 293-295**
- S-curve, crossover of, 157**
 obtaining on oscilloscope, 156-158
 production of, 155-158
 requirements for, 158
- Selectors, channel, see Tuners.**
- Separation, horizontal-vertical pulses, 223-226**
 sync from video, 207-209, 218
- Separators, sync, 221**
- Series heaters, polarity check of, 322**
 plate-cathode power supply circuit, 323-326
- Shelf, intercarrier sound response, 140**
- Shielding, alignment through, 49**
 precautions with, 173
- Shorting switch, tuners with, 163-165**
- Sidebands, carrier, 17**
- Signal, attenuator for, 172**
 composite television, 11-15
 frequency limits of, 17
 generators, see *Marker Generator and Sweep Generator*.
 television, 11-15
 types of in receiver, 7-9
- Single-peaked tuning, 87-89**
 video i-f alignment, 127-131
- Size control, horizontal, 238**
 vertical, 269
- Skewing of picture, 299**
- Slugs, alignment, types of, 169**
- Sound**
 accompanying, 97
 adjacent, 97
 alignment for, 143-160
 bars, appearance of, 117
 trap alignment with, 113
 carrier, location in channel, 17
 frequencies of, 173
 demodulators, see *Ratio detector and Sound Discriminator*.
 deviation for, 143
- Sound discriminator**
 action of, 79
 alignment, oscilloscope, 154-160
 principle of, 145
 voltmeter for, 149-152
 circuit of, 144-146
 instrument connection to, 145
 output connection to, 145
 S-curve from, 155-158
- Sound i-f amplifier response, 75**
 alignment, oscilloscope, 152-154
 voltmeter, 148-149
- Sound, intercarrier**
 action of, 72-73
 alignment for, 143-160
 buzz with, 140, 160
 oscillator tuning effect on, 76
 overall video response for, 140
 r-f oscillator alignment for, 186-189
 trap for shelf on response, 140
 video i-f alignment for, 139-141
- Sound intermediate frequencies, 87**
 ratio detector, see *Ratio detector*.
 r-f oscillator effect on, 76
 section of receiver, 71-82
 alignment methods for, 143-160
- Sound takeoffs**
 action at, 77-79

Sound takeoffs—(Cont.)
 alignment, oscilloscope, 152-154
 voltmeter for, 148-149
 locations of, 72
 trap effect of, 100
Square pulse on sawtooth, 226-227, 271, 276-277
Stacked antenna, 385
Stagger tuning, 88-91
 alignment, 127-131
Stubs, matching, at receiver, 341
Sweep amplifiers
 action of, 263-279
 electrostatic, 263-267
 horizontal, magnetic, 270-278
 linearity control on, 238-285
 plate voltage at, 278
 magnetic, 267-272
 vertical, electrostatic, 263
 magnetic, 267-270
 waveforms from, 269-270
Sweep frequency, automatic control of, see Horizontal afe.
Sweep generators
 action of, 19-25
 adjustment of, 34
 attenuator pad for, 172
 center frequencies of, 30
 connection of, 32, 109
 coupling from, 42-43
 frequencies required from, 29-30
 impedance matching for, 31, 171
 output effect on scope trace, 22
 output required from, 20-31
 phasing unit for, 28-29
 requirements for, 29-31
 sweep rate of, 21
 width required from, 20, 30
 synchronized sweep for, 26-29
 unit for, 28-29
 trace produced by, 24
Sweep, horizontal, automatic control of, see Horizontal afe.
Sweep oscillators
 action of, 227-242
 blocking type, 227-231
 discharge tube for, 231
 sync polarity for, 236
 waveforms from, 229
 horizontal afe, see *Horizontal afe.*
 multivibrator, 232-236
 horizontal afe, adjustment of, 256
 phase detector with, 254-256
 sync polarity for, 236
 waveforms from, 236
 Potter circuit for, 232
 sync polarity for, 236
Sweep, synchronized, 26-29
 phasing unit for, 28-29
Switch, rotary, tuners with, 162-165
 shorting, tuners with, 163-165
Syne (Synchronizing)
 amplifiers, 221
 clippers or limiters, 221
 polarity, for oscillator, 236
 pulse, voltage measurement of, 39-39
 section of receiver, 217-226
 action in, 222
 filters in, 223-226
 pulse separation in, 223-226
 tubes used in, 221-223
 waveforms from, 219-221
 separation, vertical-horizontal, 207-208, 223-226
 separators, 221
 takeoff points, 218
Synchronized sweep, 26-29
 phasing unit for, 28-29

Takeoffs, sound, 77-79
 alignment, oscilloscope, 152-154
 voltmeter for, 148-149
 location of, 72
 trap effect of, 100
 sync, 218
Television channels, 16-18
Television, color, 347-430
Television frequencies, 15-16
 receiver sections, 8
 signal, 11-15
Test setups, 41-43
 series heater polarity for, 322
Tilting of picture or pattern, 299
Transformers, coupling
 double-peaked, alignment of, 131-139
 response of, 136
 interstage, 125-126
 sound i-f, alignment, scope, 152-154
 alignment, voltmeter for, 148-149
Transmission distance, 327
 lines, 337-342
 impedance of, 336-338
 impedance matching for, 336, 340, 341
 losses in, 344
 vestigial sideband, 16, 35-37
Traps
 accompanying sound, location, 115
 alignment of, 113-118
 sound bars used for, 118
 antenna circuit, 102-104
 alignment of, 179
 circuits used for, 98, 102
 frequencies for, 100
 intercarrier beat, 104-106, 203
 sound shelf, 140
 interference types of, 96-104
 ion, 304-306
 adjustment of, 306
 location of, 99
 narrow band amplifier, 100
 need for, 96-97, 100
 r-f, 102-103
 alignment of, 179
 sound takeoff as, 100
 types of, 98-100
 video i-f response affected by, 118
Trimmers, tuner, overall adjustment with, 166-168
Troubles, preliminary tests for, 10
 table for locating, 4
Tubes, see names of types, functions, or parts in which used.
Tuners
 action of, 51-70, 161-170
 alignment of, 161-192
 check, with video i-f, 189-192
 general instructions for, 161-170
 inductor of coil types for, 170
 r-f amplifier, 172-173
 antenna connection to, 60-62
 continuous, 55-56, 167-168
 eight channel type, 66-67
 inductors used in, 170
 overall trimmers in, 166-168
 parts of, 3
 rotary switch types of, 52-55, 62-64, 162-165
 shorting switch types of, 54, 163-165
 turret types of, 67-68, 165-167
 two-band continuous, 56, 68-70, 167
 types of, 60-62, 161-170
 ultra-high frequency, 386

Tuning

- capacitance for, 53
 - methods of, 52-56
 - single-peaked, 87-89
 - staggered, 88-91
 - video i-f stage, 87-91
 - wand for, 170
- Turret tuners, 67-68, 165-167
- Two-band antennas, 332-335
- tuners, 56, 68-70, 167

V

Vacuum tube voltmeter, see *Electronic voltmeter*.

Vertical amplifier, electrostatic, 263

- magnetic, 267-270
 - waveforms from, 269-270
- filter, sync, 223-226
- hold control, 238-242
- adjustment of, 241-242
- linearity control, 234-235
- size control, 269
- sync pulses, 11
- separation, 223-226
- waveforms from, 219-221, 225
- Vestigial sideband transmission, 16
- receiver attenuation for, 85-87
- Video amplifier, 202-203
- waveform observation on, 201
- carrier, frequencies for, 178
- location in channel, 17

Video detector

- action of, 193-198
- circuits for, 196
- crystal type, 197
- signal polarity from, 194, 198
- test points for, 196-197
- waveform at output of, 199-201

Video i-f

- alignment, 118-125
- double-peaked stage, 131-136
- instruments for, 120
- connections of, 123-124
- intercarrier sound, 139-141
- overall check of, 189-192
- r-f oscillator removed for, 123
- separate stage, 136-138
- single-peaked stage, 127-131
- stage by stage, 124-125
- stagger tuned stage, 127-131
- amplifiers, 83-106
- couplings in, 84-85
- oscillation in, 141
- overall check of, 189-192
- couplers, 137
- responses, 74, 85-87
- alignment changes of, 131, 135
- intercarrier sound, 75, 139-141
- intermediate stage, 137
- overall, 137-139
- peaks in, 141
- requirements for, 118-119

Video i-f (Cont.)

- stage, 127, 129
 - touchup adjustments for, 133
 - trap effect on, 97, 118
 - traps in, see *Traps*.
 - tuning in, 87-89
- Video intermediate frequencies, 87
- Video-sound i-f amplifier, see *Video i-f*.
- Video-sync separation, 207-209, 218

Voltage

- booster, damper as, 231
 - divider, electronic voltmeter, 47-49
 - series tubes for, 322-326
 - doublers, 313-315
 - measurements, 48-49
 - horizontal amplifier plate, 278
 - oscilloscope for, 38-39
 - multipliers, power supply, 313-315
 - voltmeter type, 47-48
 - peak-to-peak, 39
 - receiver, 43
 - regulation, audio amplifier for, 325-326
 - sawtooth, see *Sawtooth voltages*.
- Voltmeter, electronic, see *Electronic voltmeter*.
- high-voltage connection to, 45
- prods for, 45

W

Wand, tuning, 170

Waveforms

- blocking oscillator, 229
 - damper tube, 231
 - deflection coils, 298
 - drive control, 278, 276-277
 - electrostatic deflection, 266
 - horizontal a/c, 253, 258
 - sync, 225
 - multivibrator oscillator, 235
 - observation of, 198-202, 219-221
 - peak-to-peak voltage in, 39
 - sawtooth, 229
 - sync filter, 225
 - section, 219-221
 - vertical amplifier, magnetic, 269-270
 - sync, 225
 - voltage measurement on, 38-39
- Wavelengths, channel, vhf, 329
- uhf, 332
- Wave traps, see *Traps*.
- White level, 13
- Width
- anode voltage effect on, 293
 - controls, 238
 - output transformer, 273
 - drive control effect on, 272
- Wiring, dressing of, 49

Y

- Yoke, deflection, 293
- rotating picture with, 299

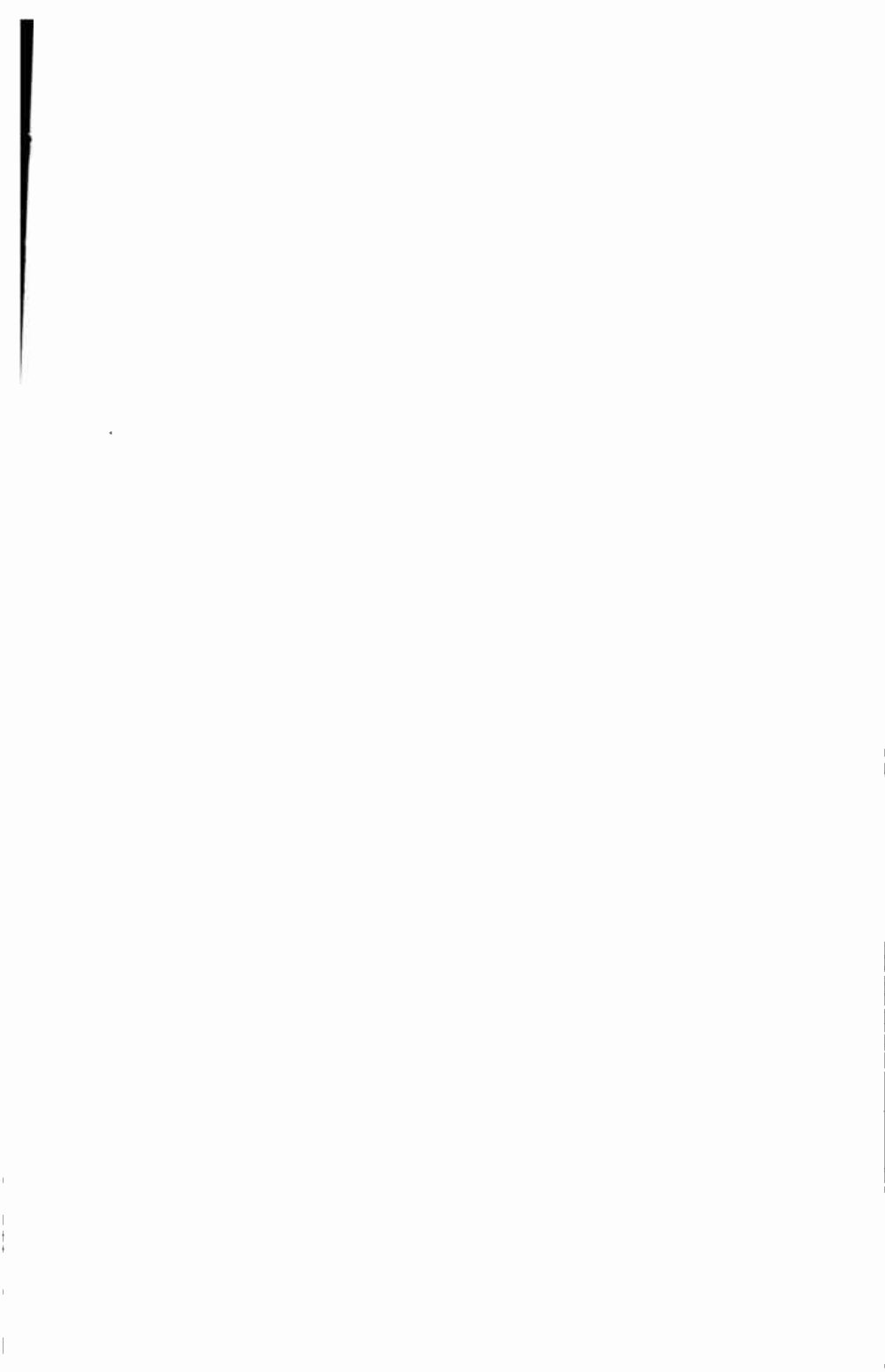



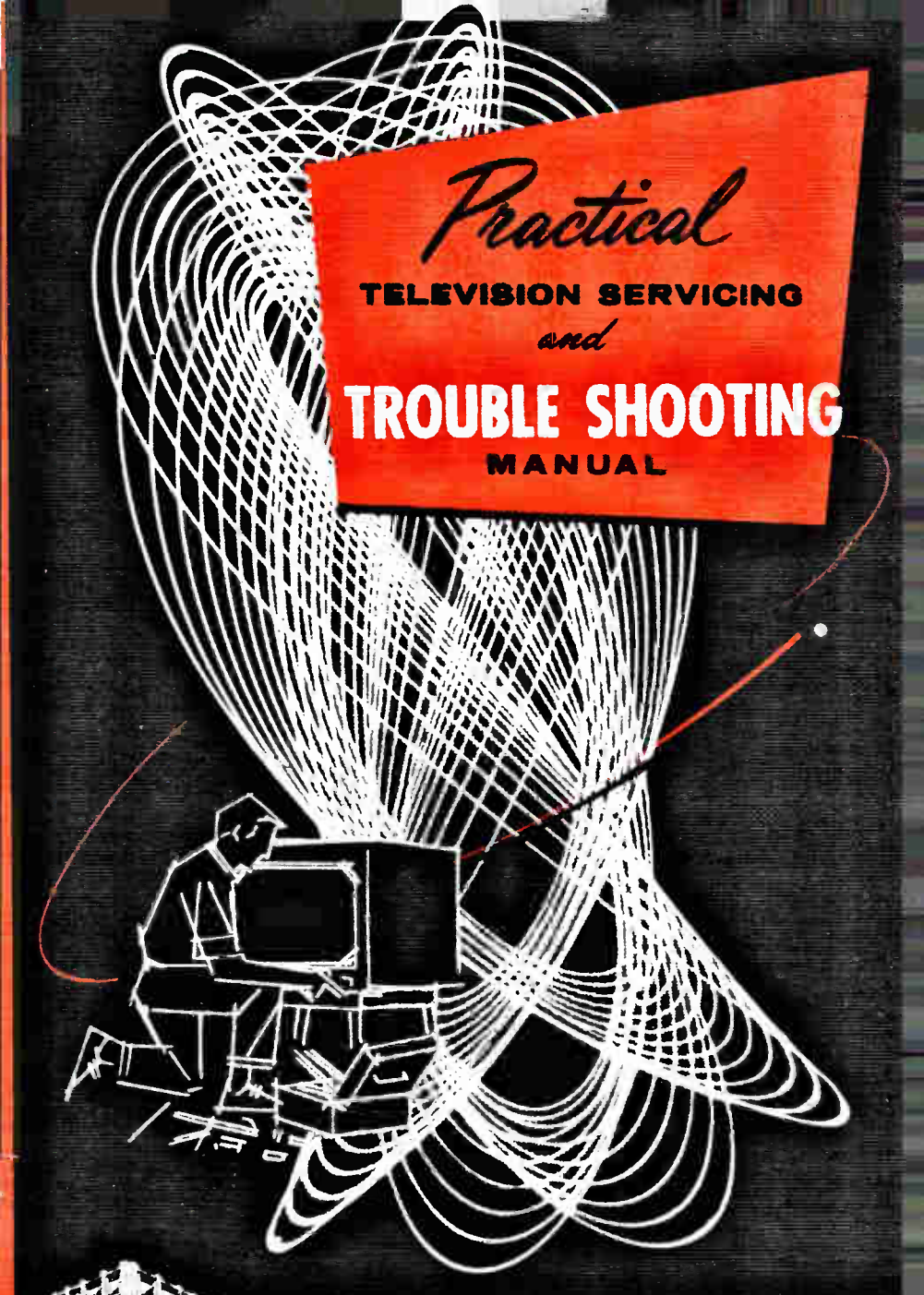

Practical
TELEVISION SERVICING
and
TROUBLE SHOOTING
MANUAL



A *Coyne* PUBLICATION