

# COMMUNICATIONS

INCLUDING "RADIO ENGINEERING" AND "TELEVISION ENGINEERING"

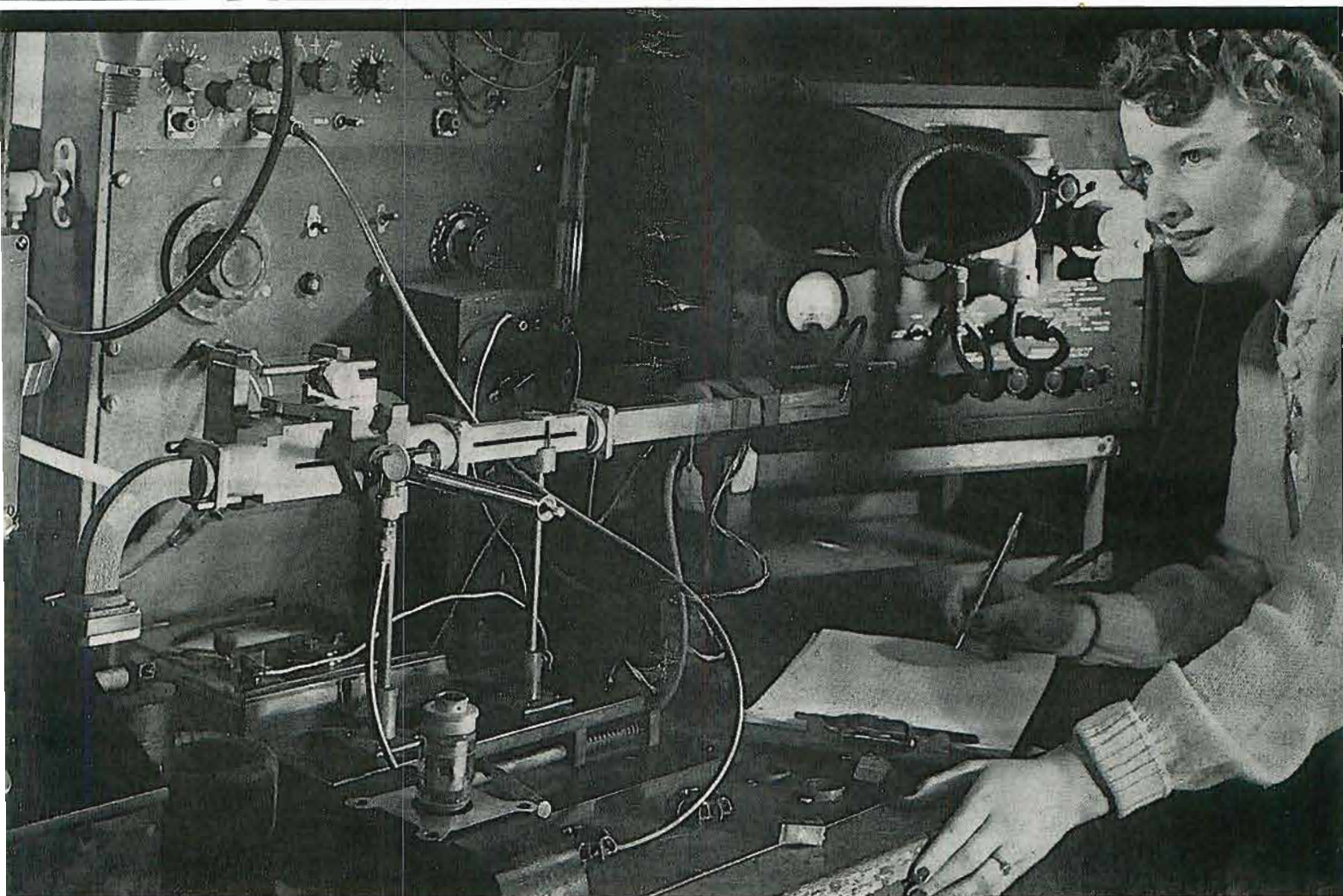

MAY

- ★ ONE-MAN FM-STATION OPERATION
- ★ RF COIL DESIGN WITHOUT MATH
- ★ REPORT ON THE NAB BROADCAST ENGINEERING CONFERENCE

1949



# IMPROVED



CONTINUOUS  
TUNING FROM  
FRONT PANEL

20 KW

TRANSMITTER

C. W., F. S., PHONE

## Improved Continuous Tuning

Continuously tunable from the front panel over a frequency range of 10 to 1. Tuning circuits simple to operate.

## Maximum Operating Continuity

Recycling overload relays insure against loss of operating time due to temporary overloads. Control circuits fulfill rigid broadcast requirements.

## Cool Operation

Electrical short circuiting of sources of resistance assures unusually cool and efficient operation.

## Safe Operation

Automatic-safety grounding switches used on all cabinet doors and housing openings. All operating controls are grounded. Interlocked control circuits.

## Easy to Maintain and Service

Components are readily accessible and individually removable for replacement and repair.

## Continuous Tuning Plate Circuit

- Frequency changes can be made in a few seconds.
- Alternate paths for current around moving parts of circuit provide high efficiency and cool operation.
- Glass-bonded mica assembly supports inductances by holding coils rigid — permits precision adjustment of coil relationship.
- All parts removable and easily accessible to operating personnel.



**J. H. BUNNELL & Co.**

215 FULTON STREET • NEW YORK 8, N. Y.,  
DEPT. 14

**BUNNELL—A KEY WORD IN  
COMMUNICATIONS EQUIPMENT**

Research, Engineering, Production, and Testing facilities for equipment for: Wire Lines • Submarine Cables • Railroad Communication • Radio Airway Systems • Municipal Signaling • Army and Navy Signaling • Carrier Current • Automatic Telegraph • Facsimile



The Du Mont Types 5130-B and 5130-C 16 mm. television projectors are designed and built for the rugged requirements of film telecasting. Greater reliability for day-in-day-out operation. Readily accessible mechanism. Easily replaceable parts. Feature-length reel capacity. Maximum optical resolution. Greater light output. High-fidelity sound. Either type recommended, based on style and feature preference.

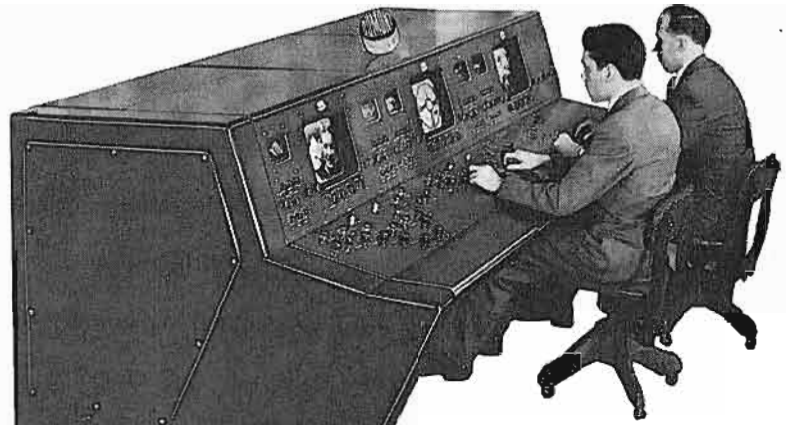
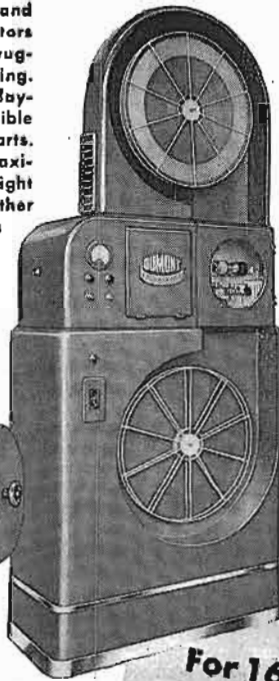
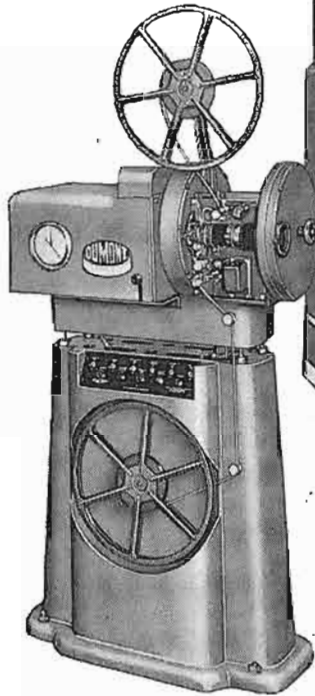

Du Mont Type TA-105-A Film Pickup Control Console. Includes saw-tooth, parabola and sine-wave shading with 5" waveform monitors for both line and frame. 12" picture monitor. Instantly accessible chassis.

Integral design with the Du Mont Type TA-108-B Video Mixing Console and associated equipment which will handle four separate video or composite input channels with automatic or manual "fades" and "lap dissolves" between any video input channels.

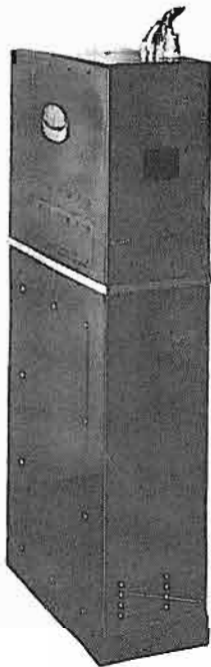

For 16 mm. sound-film economy... maximum pictorial resolution... high-fidelity sound... good audience reaction and real sponsor satisfaction—  
**PLAY SAFE WITH A DU MONT**

## Iconoscope Film Pickup SYSTEM

Here's fully-coordinated engineering. From projector to control console, there are no weak links. Each unit does its job as thoroughly as that job can and should be done.

First, a choice of two types of Du Mont projectors designed from scratch and built by specialized craftsmen to insure superlative images and sound from 16 mm. films. Then the Du Mont

Iconoscope Film Pickup Head to translate pictorial resolution into precise electronic signals. Finally, the Du Mont Control and Video Mixing Equipment to monitor the pickups for a smooth-flowing program.

"Portions of this program have been on motion picture film" takes on new meaning when handled with Du Mont equipment throughout.

Details on request. Remember, Du Mont means "First with the Finest in Television" from camera to transmitter, and again to the finest telecasts\* made.

\*Trade Mark

Du Mont Type TA-103-A Iconoscope Film Pickup Camera. An ideal pickup head for film or slides, using the high-resolution Iconoscope Type 1850-A. Special rim light and back lighting arrangement. Available with fixed pedestal or sliding-track mounting for handling two or more image sources. Mechanical construction such that all components are readily accessible.

© ALLEN B. DU MONT LABORATORIES, INC.

# DU MONT

*First with the Finest in Television*

ALLEN B. DU MONT LABORATORIES, INC. • TELEVISION EQUIPMENT DIVISION, 42 HARDING AVE., CLIFTON, N. J. • DU MONT NETWORK AND STATION WABD, 515 MADISON AVE., NEW YORK 22, N. Y. • DU MONT'S JOHN WANAMAKER TELEVISION STUDIOS, WANAMAKER PLACE, NEW YORK 9, N. Y. • STATION WTTG, WASHINGTON, D. C. • HOME OFFICES AND PLANTS, PASSAIC, N. J.

COMMUNICATIONS FOR MAY 1949 • 1



# COMMUNICATIONS

Including Television Engineering, Radio Engineering, Communication & Broadcast Engineering, The Broadcast Engineer, Registered U. S. Patent Office.

## LEWIS WINNER

Editor

F. WALEN

Assistant Editor

Bryan S. Davis, President

Paul S. Weil, Vice Pres.-Gen. Mgr.

F. Waleen, Secretary

A. Goebel, Circulation Manager

### Cleveland Representatives:

James G. Mann  
2250 Delaware Dr., Cleveland 4, Ohio  
Telephone: Erlwin 1728

### Pacific Coast Representative:

Brand & Brand  
1822 W. Sixth St., Los Angeles 14, Calif.  
Telephone: Michigan 1732  
Bills 1294, Ross Building, San Francisco 4, Calif.  
Telephone: Sutter 1-2251

Wellington, New Zealand: Te Aro Book Depot.  
Melbourne, Australia: McGill's Agency.

Entered as second-class matter Oct. 1, 1937 at the Post Office at New York, N. Y., under the act of March 3, 1879. Subscription price: \$2.00 per year in the United States of America and Canada; 25 cents per copy. \$3.00 per year in foreign countries; 25 cents per copy.

COMMUNICATIONS is indexed in the Industrial Arts Index and Engineering Index.

## COVER ILLUSTRATION

Power from a magnetron, being pulsed through a waveguide system (center) during a check on power output and efficiency. (Courtesy Sylvania Electric Products, Inc.)

## BROADCAST ENGINEERING

The 1949 NAB Broadcast Engineering Conference ..... 8  
*Highlights of the Three-Day Meeting in Chicago.*

TV-FM Field Intensity Measurements ..... George P. Adair 14  
*Essential Equipment and Methods Used in Actual Field Operations By Former FCC Chief Engineer.*

## COMPONENT DESIGN

RF Coil Design Using Charts ..... Peter G. Sulzer 10  
*Plots Eliminating Need For Math, Provides Inductance and Number of Turn Data.*

## TELEVISION ENGINEERING

Tube Engineering News ..... K. A. Hoagland 12  
*CRT, Designed for Wide-Band 'Scope Work, Affords Observation and Recording of Wave Forms, Containing HF Components Which Appear in Video and Pulse Transmitting and Receiving Equipment.*

A Visit to WOR-TV ..... 21  
*Features of Channel 9 Station, With Tower 1,050' Above Sea Level, Soon To Go On Air.*

## COMMUNICATION SYSTEM ENGINEERING

Balanced 2-Wire Method to Reduce Ignition Interference ..... V. Welge 22  
*3-Wire Method Found Superior to Suppressor Or Shielding Procedures in Minimizing Ignition Interference in Communication Systems.*

## FM BROADCASTING

FM Station Design for One Man Operation ..... Max Alth 28  
*WGMR, New Rochelle, Design Permits One Person To Serve As Engineer, Announcer and Platter Turner.*

## MONTHLY FEATURES

News and Views ..... Lewis Winner 7  
Veteran Wireless Operators' Association News ..... 27  
The Industry Offers ..... 32  
News Briefs of the Month ..... 34  
Last Minute Reports ..... 36  
Advertising Index ..... 36

Entire contents Copyright 1949, Bryan Davis Publishing Co., Inc.



Published monthly by Bryan Davis Publishing Co., Inc.  
52 Vanderbilt Avenue, New York 17, N. Y. Telephone MURRAY Hill 4-0170



## IN A RADIO SET

*how small  
can you get?*

### Sylvania's four tiny new tubes hold the answer

The miniature radio set shown here is an example of what can be done through the use of Sylvania's new subminiature tubes.

These specially designed and engineered T-3 subminiatures are battery-type receiving tubes perfect for very small radios or amplifiers. Short tube leads provided in conventional pin arrangement permit these tubes to be plugged into appropriate subminiature sockets. They can be operated over a wide range of battery voltages. Low current requirements result in battery economy.

*Send for complete ratings and characteristics.  
Sylvania Electric Products Inc., Advertising  
Dept., R-1305, 500 Fifth Ave., New York 18, N. Y.*



Four new Sylvania subminiatures shown in place in tiny radio set. Note size in relation to pencil.

Type 1T6 (diode pentode)      Type 1E8 (converter)      Type 1AC5 (output pentode)      Type 1AD5 (RF pentode)

# SYLVANIA ELECTRIC

RADIO TUBES; CATHODE RAY TUBES; ELECTRONIC DEVICES; FLUORESCENT LAMPS, FIXTURES, WIRING DEVICES, SIGN TUBING; LIGHT BULBS; PHOTOLAMPS

COMMUNICATIONS FOR MAY 1949 • 3

# *Introducing* A NEW TEAM



## Combining Research—Development—Manufacturing Skill

Here's great news for Broadcasters. Machlett Laboratories and Graybar Electric Company have joined forces in a new distribution line-up to bring you more efficient and complete service on electron tubes.

For over 50 years, Machlett has pioneered and made notable contributions to the development of the electron tube art. Today, through its modern plant, development laboratories and skilled personnel, Machlett tubes will set the highest standard of performance in broadcast service.

This combination of Machlett and Graybar is your best assurance of getting superior tubes. For better value—better service—try Machlett tubes now distributed via Graybar.

**MACHLETT**

OVER 50 YEARS OF ELECTRON TUBE EXPERIENCE

Famous as the outstanding manufacturer of X-ray tubes, the name, Machlett, on electron tubes has been the mark of quality, top performance and long life for more than 50 years. Experience, skill and a "singleness of purpose" to produce the best in electron tubes have made Machlett first choice around the world.

**MACHLETT LABORATORIES, INC., Springdale, Connecticut**



# TO SERVE BROADCASTERS . . .

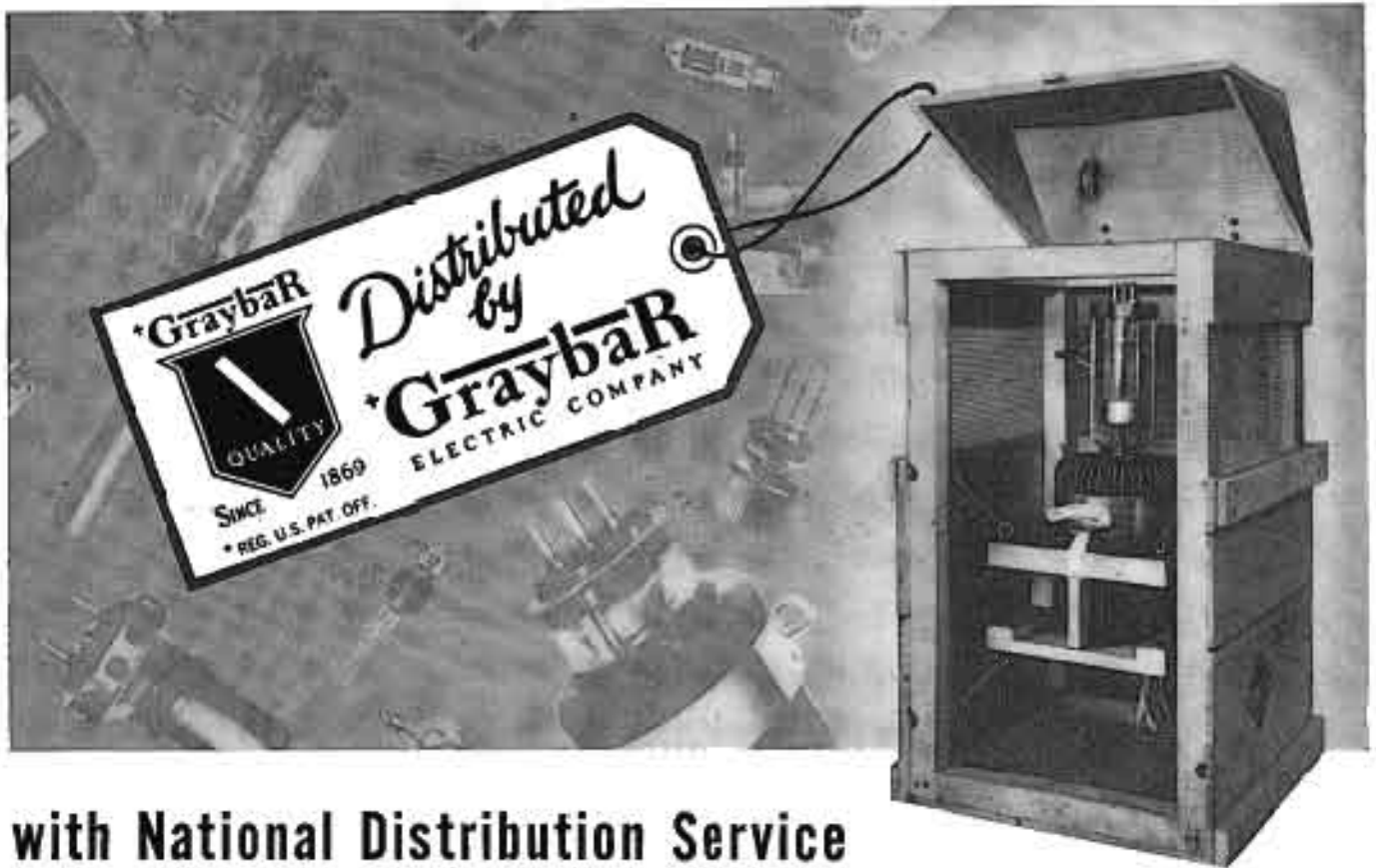

## with National Distribution Service

In keeping with its policy of "Bringing You Broadcasting's Best Equipment," Graybar is proud to assign its Tag—the Symbol of Distribution—to the Machlett line of electron tubes.

This new connection will bring you dual benefits: (1) products from an outstanding manufacturer of electron tubes, (2) distribution service from an organization offering specialized assistance in choosing the best type of product for your requirements.

Machlett tubes can now be quickly and conveniently ordered through near-by Graybar "Supply Stations" located in over 100 principal cities from coast-to-coast. When you order Machlett tubes "via Graybar," you'll have the right combination for extra service and performance.

Call your local Graybar Broadcast Equipment Representative. Graybar Electric Co., Inc., Executive Offices: Graybar Building, New York 17, N. Y.

EVERYTHING ELECTRICAL TO KEEP YOU ON THE AIR



These are the Graybar Broadcast Equipment and Electron Tube Specialists in key cities:

**ATLANTA**  
E. W. Stone, Cypress 1751  
**BOSTON**  
J. F. Lynch, Kenmore 4-4567  
**CHICAGO**  
E. H. Taylor, Canal 4104  
**CINCINNATI**  
J. E. Thompson, Main 0600

**CLEVELAND**  
W. E. Rockwell, Cherry 1360  
**DALLAS**  
C. C. Ross, Central 6454  
**DETROIT**  
F. L. Gandy, Temple 1-5500  
**JACKSONVILLE**  
W. C. Winfree, Jacksonville 5-7180

**KANSAS CITY, MO.**  
R. S. Uhlir, Grand 0324  
**LOS ANGELES**  
R. S. Thompson, Trinity 3321  
**MINNEAPOLIS**  
W. G. Pies, Geneva 1621  
**NEW YORK**  
F. C. Sweeney, Watkins 4-3000

**PHILADELPHIA**  
G. I. Jones, Walnut 2-5405  
**PITTSBURGH**  
R. F. Grossett, Court 4000  
**RICHMOND**  
E. C. Tom, Richmond 2-2633

**SAN FRANCISCO**  
K. G. Morrison, Market 5131  
**SEATTLE**  
D. I. Craig, Main 4635  
**ST. LOUIS**  
J. P. Lenkerd, Newstead 4700



**Worth Looking Into!**

## **KELLOGG CARRIER**

- *Saves Construction Costs and Improves Transmission Quality*
- *Offers You These Outstanding Features*

1. **GIVES LONG-HAUL PERFORMANCE AT SHORT-HAUL COST.** Provides a 6 db talking circuit over circuit 30 db long (measured at 11-KC). Will operate thru substantial lengths of high-loss cable, such as 22-ga. exchange cable. Ordinarily does not require impedance matching devices for reducing reflection losses caused by junction of open wire and cable.
2. **POSITIVELY DEPENDABLE.** Solidly built of rugged, telephone-type components with advanced circuit design. Gives long, trouble-free operation, regardless of heat or humidity.
3. **EASY TO INSTALL.** Mounts on any 19" equipment rack, requires only 8 external connections after intercabling of units.
4. **SIMPLE TO USE,** with all adjustments except voice and carrier output-level pre-set at factory. Needs no oscillator synchronization, no frequency adjustments in the field.
5. **FREE FROM MAINTENANCE WORRIES.** Needs only the occasional replacement of a vacuum tube.
6. **FLEXIBLE**—Designed on "unit" basis for easy adaptation to various applications. Adding second carrier channel requires only a few external connections. (Models available too, to meet every need.)

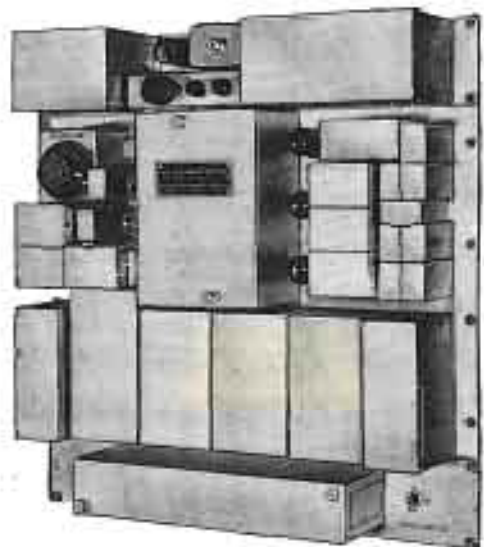

Kellogg No. 5A single-channel carrier system permits transmission of two conversations simultaneously over a two-wire metallic circuit. Doubles traffic facilities without the expense of added wire, extra maintenance or heavier poles. Considering the cost of materials and manpower today, this means real savings. Improves transmission quality too, by eliminating powerline hum.

**SEND COUPON FOR COMPLETE DATA TODAY!**

**KELLOGG** SWITCHBOARD AND SUPPLY COMPANY  
CARRIER

KELLOGG SWITCHBOARD AND SUPPLY COMPANY  
4450 So. Cicero Avenue  
Chicago 38, Illinois

Please send full details on your carrier systems

NAME: \_\_\_\_\_

ADDRESS: \_\_\_\_\_

CITY: \_\_\_\_\_ STATE: \_\_\_\_\_



# COMMUNICATIONS

LEWIS WINNER, Editor

MAY, 1949

## At The Engineering Conferences

THE MANY FACETS of broadcast engineering were shrewdly probed by quite a battery of station, field, lab and plant men at the recent Windy City and City of Brotherly Love meetings. In Chicago, where the NAB held its third annual affair and Philadelphia where the joint RMA-IRE transmitter sessions were held, it became more obvious than ever before that broadcasting was becoming a more complex business every day, and in every way.

TV, contributing to most of the complications, and now beset by the freeze and *uhf* headache, was a topic of discussion everywhere, in the meeting and exhibition rooms and in the lobbies. In one of the most comprehensive analyses of the *uhf* situation ever presented, Thomas T. Goldsmith, Jr., DuMont Lab director of research, said that only by initiating *uhf* TV broadcasting quickly, to affect widespread studies of systems and propagation, can we hope to compile the answers so urgently needed for the future of ultrahigh telecasting.

Citing the program WABD has set up to gather such data, he said that a pair of transmitters for picture and sound, operating on frequencies of 609.25 and 613.75 mc, respectively, will soon be on the air from 515 Madison Avenue, New York City. Using an omni-directional antenna with a substantial power gain, it is expected that a peak *erp* of several kw will be available.

In Washington, Boston, San Francisco and Chicago, ultrahigh transmitters have been on the air for many months, in an effort to correlate propagation information. And plans are now afoot to expand this work in these and other areas.

Goldsmith accented the tube problem, declaring that ultrahigh transmitters may require special tube structures such as the resonatron, the high powered tube constructed so that its resonant circuits are fundamentally a part of the tube structure itself, used quite successfully during the war as a jamming device. Other possible solutions to the tube problem cited included multiple tubes in a ring circuit, multiple tubes excited in a balanced

manner and also special types of triodes and tetrodes, such as were described by Dr. Howard Doolittle at the meeting<sup>1</sup>.

Discussing transmitter neutralization at the ultrahighs, Goldsmith said that it is quite a serious problem, the power stages requiring satisfactory neutralization in order to enable the transmitter to be modulated to a depth as low as 15% on peaks of white. And in addition, phase modulation must be minimized on such transmitters if it is desired to employ the intercarrier method of sound reception in receivers.

The all-important problem of receivers for ultrahigh pickup was also mentioned by Goldsmith, who indicated that the single superhet circuit appeared to be the most satisfactory means of reception in these channels. In one model built, a special *uhf* head and assembly was used and simply switched into the *if* input. It has been found quite satisfactory to use the 21.9 mc sound *if* and 26.4 mc video *if*. With this system, it's been possible to secure an image rejection of better than 10 db; an *rf* tuned cavity was employed ahead of the crystal detector to provide this rejection and another tuned cavity served for the local oscillator.

Covering the possible channels that might be used for ultrahigh work, Goldsmith said that there should be about sixty-nine additional six-mc channels available, but that it may be necessary to use from forty to fifty-five of the channels in a conservative spacing program.

The problem of films<sup>2</sup> was another particularly keen subject, not only in Chicago, but in Philadelphia, too. In view of the unusual amount of film now being used in syndication work alone, the boys discussed the possibility of setting up a thirty-frame standard which might even become a standard in the film industry. The liaison work initiated at the recent SMPTE conference should not only be maintained but perhaps increased, the TV film men said. Pointing out the features of the thirty-frame film, the boys said that this type of film would permit the use of the flying spot scanner and increased application of 16-mm stock which would afford better sound. It was also pointed out that the use of the special film having a lower Gamma would be an additional advantage.

Standardization of television transmitters was another topic thoroughly discussed at the meetings. It appears as if the physical and electrical variations in designs have prompted broadcast engineers to stress the interchange problems which exist. The transmitter design engineers felt that the problem might be solved by standardizing special type of equipment such as pulse light projectors,

wherein perhaps the same pulse would be used in all projectors. It might also be possible to use the same type of output plugs, jack assemblies, etc., to permit equipment interchange.

Undoubtedly, as the months go by, other standardizing possibilities will appear and receive serious consideration for future application.

With the advent of TV and its highly specialized branches has come another broadcast-station problem, the training of engineers. Discussing this point at the Chicago meeting, Whitney M. Bastion, technical training director of NBC, said that prior to the late war, the turnover of broadcast operating personnel was small and replacements could be chosen from a group of operating engineers who had at least several years experience in the industry. However, broadcasting lost the services of many of its skilled technicians during this period and as a result the turnover among operating engineers greatly increased. Accordingly, at NBC, it was found necessary to introduce a training program to serve a two-fold purpose; to train new sound broadcast engineers to replace the transferees and the training of new TV engineers.

Commenting on the schooling applicants must have, Bastion said that two years of basic electronic study have been found to be the minimum educational requirement. Approximately 25% of the number selected are graduate electrical engineers who have specialized in communications and electronics. It was pointed out that this employment policy is intentional to provide experienced and technically qualified engineers for future supervisory, design, development and executive positions.

The over-all training program at NBC now covers each branch of operating engineering, including AM and FM studios, field, maintenance, master control, recording, television studios, film studios, and picture tube recording.

Present plans include four weeks of training in standard audio operating practices and six months of specialized TV training.

The variety of papers presented at Chicago contained so much other invaluable information that should be published, that we decided to present in COMMUNICATIONS most of the NAB papers in unabridged and completely illustrated form. The first of these presentations covering *TV and FM field-intensity measurements* by George Adair appears in this issue. Next month will appear the site measurement paper by Ed Clammer of RCA and the H. D. Doolittle (Machlett) presentation on triodes and tetrodes for high-frequency operation.

We, and we are sure everyone, are grateful to those who appeared on the rostrums in Chicago and Philadelphia for their topical presentations, which can only spell a successful future for broadcasting. —L. W.

<sup>1</sup>This paper will appear in the June issue of COMMUNICATIONS.

<sup>2</sup>See NAB report, this issue.

# The 1949 NAB Broadcast



Representatives of the FCC who appeared at the round-table *Commission-Industry* session at the NAB meeting in Chicago (left to right): E. A. Allen, Jr., chief of the technical information division, engineering bureau; E. W. Chapin, chief of the lab division at Laurel, Maryland; H. S. Comperthwaite; C. M. Braun, chief of the FM broadcast division; J. E. Barr, standard broadcast division chief, and J. A. Willoughby, acting chief engineer. At rear, looking on during the sessions, ye editor and Royal V. Howard, NAB director of engineering.



Herbert E. Taylor, Jr., of DuMont, explaining operation of the TV monitor console in the exhibition hall during the NAB Convention. Note display of TV motion picture equipment in background.

At the head table during one of the NAB luncheon meetings (left to right): T. A. M. Craven; Dr. T. T. Goldenmith, Jr.; E. M. Johnson; J. V. L. Hogan; FCC Commissioner E. A. Webster; NAB vice president A. D. Willard, Jr.; NAB assistant engineering director Neal McNaughton and Dr. Lincoln R. Theismeyer, executive assistant to the director of the Brookhaven National Laboratory, who addressed the session on atomic energy and the broadcaster.



THE THIRD ANNUAL NAB Broadcast Engineering Conference played host, this year, to industry's towering youngster, TV.

In the exhibition hall and in the meeting rooms, TV dominated the scene, with particular emphasis on film. The variety of photographic gear displays and extensive application commentaries left no doubt that broadcast engineers will have to become photographic experts, too. The report of Ralph V. Little, Jr., supervisor of the theatre TV engineering section of RCA Victor, served to accent this point. He noted that over a quarter of a million feet of motion picture film are being used each week by the TV stations in New York City alone to record programs.

His report contained an extremely interesting discussion of the mechanical and electronic shutter systems which can be for exposure work. Mechanically, the camera and shutter are driven by sync motors and are in synchronism with the entire TV system. The shutter drive, which is isolated from the main camera drive, is driven by a 3,600 rpm sync motor which drives the shutter at the necessary 1,440 rpm through a set of precision gears. Another motor working in sync with this setup drives the film transport and intermittent mechanism, to insure rotational accuracy and freedom from interaction of the camera drive and shutter-drive mechanisms. In the electronic system the exposure is controlled by biasing the picture tube image on and off by a special blanking signal. This method eliminates the need for the moving camera shutter and substitutes an exposure control circuit which is initiated by a contact on the camera, operating in proper phase relationship with the film transport which closes after the pulldown is complete. The electronic system does not require synchronization between the camera and TV signals. The incoming video signal supplies the keying information so that the position of the blanking of the picture tube, which is usually a 5" flat-face aluminized projection type tube with a short persistence blue phosphor screen, can change in phasing, but the exposure duration will always be correct because the information is obtained from the television signal.

The Little report also revealed that 1,200' of film are required to record a half-hour performance. Quite a bit of film for just one thirty-minute show,



# Engineering Conference

of which there are many during the normal television broadcasting day.

An indication of the growing importance of film was also evident in the displays, particularly one exhibit, a complete automatic film developer, which could be used for negative or positive processing, with speeds of 18' to 35' per minute.

The progress made in tape recording was another highlight feature at the conference. This year tape recorders, with many unusual high fidelity features, were demonstrated in the exhibition hall and display rooms at the Stevens Hotel where the convention was held.

Features of the equipment included sync motors with two windings providing instantaneous change of recording speed to either 15" or 7 1/2" of tape per second. The 15" speed of one instrument provided thirty-three minutes of continuous recording with 15-ke response.

Another tape recorder manufacturer reported that the distortion in his system, from input to output terminals, did not exceed 4% intermodulation distortion, using measuring frequencies of 40 and 2,000 cps with the high frequency attenuated 12 db. This manufacturer also stated that the total rms harmonic distortion did not exceed 1% overall for any single frequency from 100 to 6,000 cps and 2% for any frequency from 30 to 100 cps.

Commenting on the playback amplifier, a representative of this manufacturer.

(Continued on page 30)

Kinophoto system designed by RCA to record TV images on motion picture film which was on demonstration also during the NAB Convention. The equipment consists of a projection type kineoscope with its associated video amplifier, deflection circuits and power supply, and a suitable 16-mm or 35-mm sound motion picture camera. Picture tube and camera are mounted on a double cabinet rack which houses the amplifiers, power supplies, control panel and scope.



Recently developed magnetic tape recorder unit demonstrated by Press at the NAB meeting in Chicago.



At another NAB luncheon session (left to right): Ray Guy; IRE proxy Stuart Bailey; NAB proxy Judge Justin Miller; Royal Howard; Dr. William L. Everitt who appeared as guest speaker during this session and A. James Ebel, chairman of the NAB executive engineering committee.

Paul D. Sparr, factory rep of the Houston Corporation, inspecting film being processed in an automatic film developer which was on display at the NAB Convention. Designed especially for TV work, the equipment affords reversal processing of black and white 16-mm films at a speed of 18' to 35' per minute. Setup contains the solution and wash tanks, drying cabinet, two solution circulating pumps, refrigeration system, solution heater, thermometer, footage counter, three electric motors, and a film transport mechanism with variable speed transmission. Three film magazines of 1200' capacity are provided for loading the exposed film in a dark room and to allow operation of the equipment in white light.

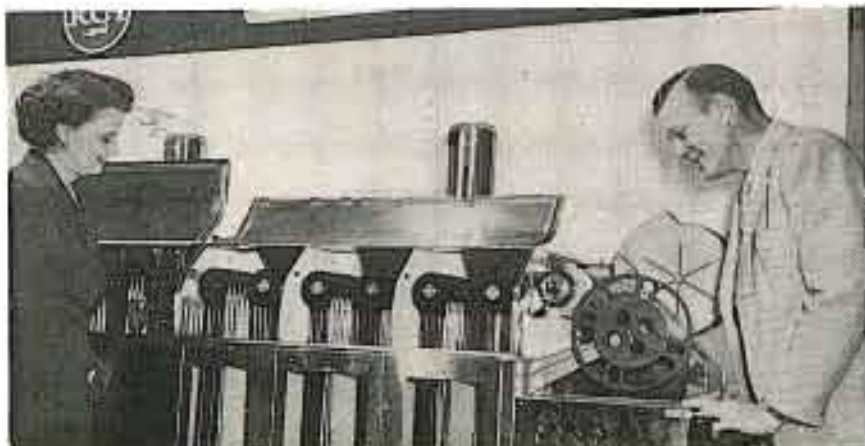

# RF Coil Design Using Charts

THE DESIGN of a *rf* coil is normally a laborious process, due in the main to the calculations required. In probing the problem it was found that with a chart and nomograph, the inductance and number of turns could be determined, if the capacity, resonant frequency and coil-form size were known. Conversely, knowing any other four of these quantities, the fifth could be obtained.

The chart and nomograph which

provided those data appear in Figures 1 and 2.

## Examples

As an application example, let us take the case of a coil, resonant at 1 mc with a capacity of 1,000 mmfd, which is to be wound on a form  $\frac{1}{2}$ " in diameter by 1" long. The proper points on the *F* and *C* scales of Figure 1 are first located and joined with a

straight line and the inductance, 25 microhenrys in this case, will be found on the *L* scale. Then by referring to Figure 2, and the intersection of the  $\frac{1}{2}$ "-diameter and 1"-length lines a value of 190 for coefficient *A* will be found; this is a characteristic of the coil-form size only. Referring again to Figure 1, and a straight line drawn through 25 on the *L* scale and 190 on the *A* scale, we find, on scale *N*, that 70 turns are required for the coil.

Figure 1  
RF solenoid-design nomograph. The coefficient *A*, shown in this nomograph, is identified in Figure 2.

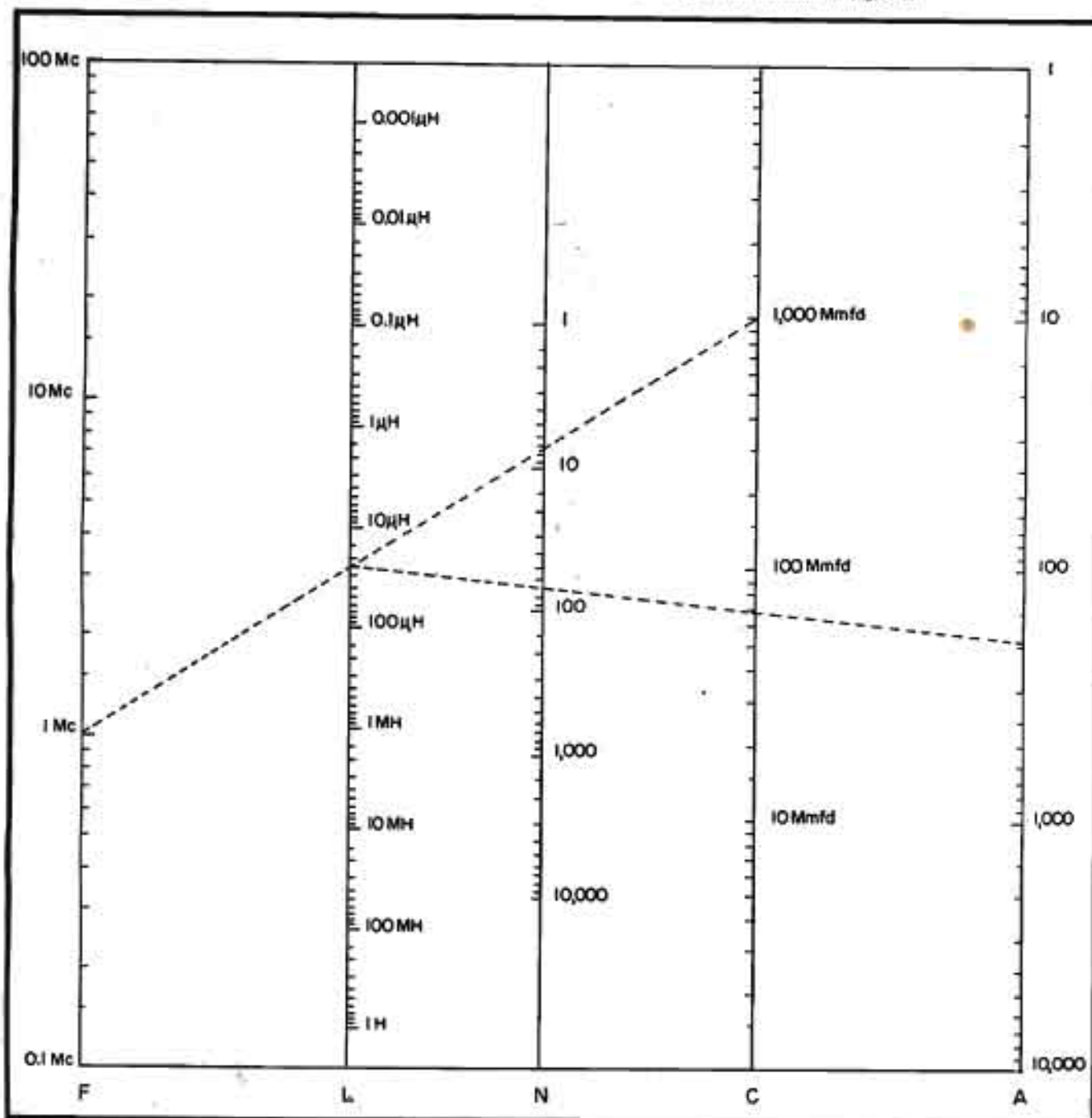



If standard-sized forms are used, with different windings, the value of  $A$  for each form can be marked directly on the nomograph, simplifying the process.

The inductance determined by this method will be somewhat in error if spaced turns or turns of large wire size are used. Also, the effects of distributed capacity are neglected. The errors are sufficiently small, however, and they can be neglected in most practical cases.

## Plots, Eliminating Need For Calculations, Provide Inductance and Number of Turn Data for $RF$ Coils, When the Capacitance, Resonant Frequency and Coil-Form Size Are Known.

by **PETER G. SULZER**

Research Assistant  
Department of Electrical Engineering  
The Pennsylvania State College

Figure 2  
Chart for coefficient  $A$ , which serves as a function of coil-form size.

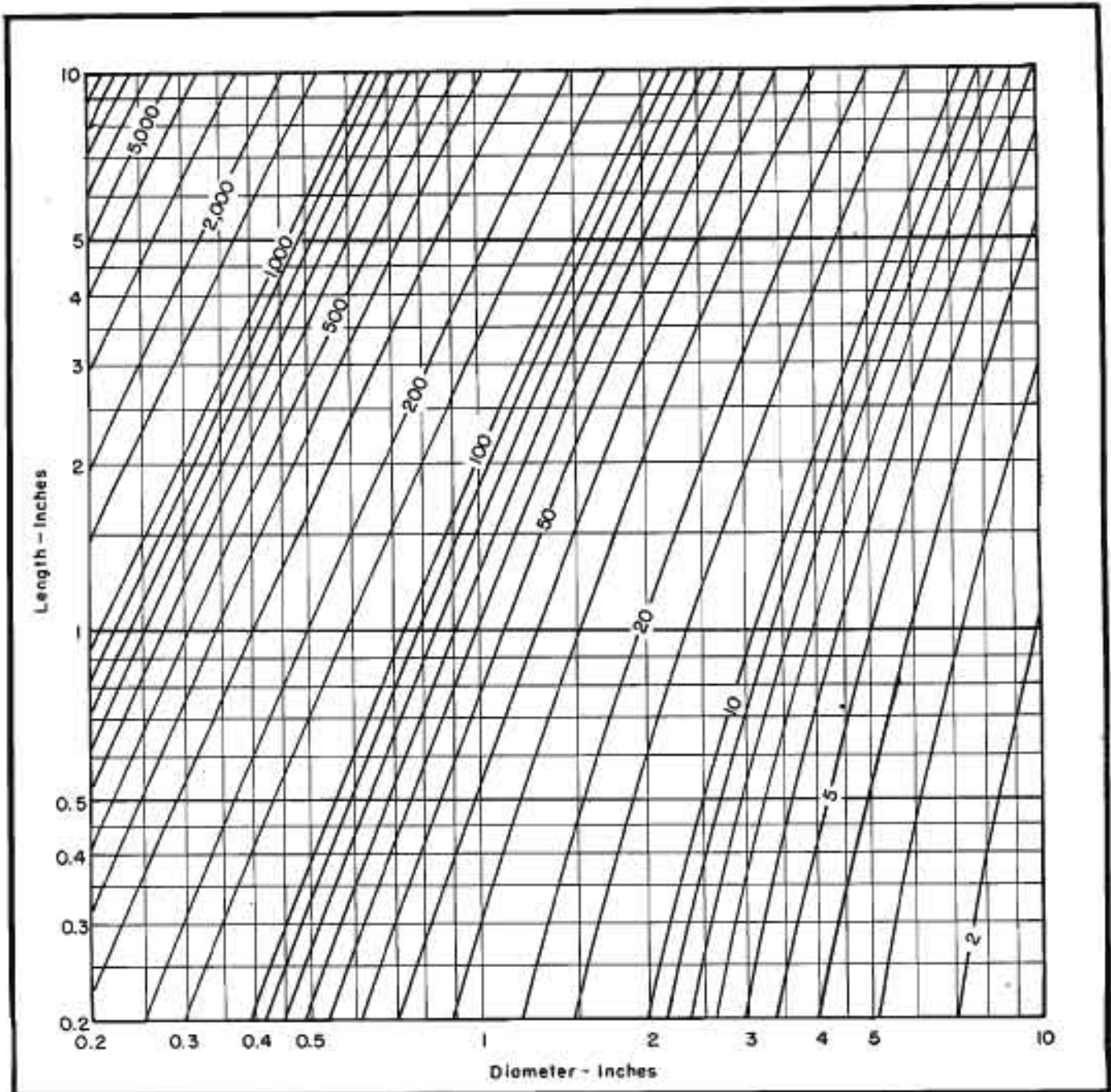

# TUBE *Engineering News*

**C-R Tube, Designed For Wide-Band 'Scope Work, Affords Observation and Recording of Waveforms, Containing HF Components, Which Appear in Video and Pulse Transmitting and Receiving Systems. Voltage Gain of Approximately 10 db in the Range from DC to 200-mc Obtained.**

by **K. A. HOAGLAND**

Tube Engineering Department  
Allen B. DuMont Laboratories, Inc.

THE CONVENTIONAL approach to the problem of designing a wide-band 'scope has been to select the best available *crt* type and then concentrate on the design of deflection amplifiers which can meet the desired specifications for bandwidth and gain. Because of the high deflection factors (low deflection sensitivities) of previously available *crt*'s the gain and bandwidth which could be achieved has been limited by the characteristic ratings of the amplifier tubes and by the power supply requirements of these amplifiers.

It was recognized that the design of a *crt* especially for use in wide-band equipment would result in improvements over existing tube types and thus simplify the deflection amplifier requirements for a given bandwidth and gain, or permit extension of bandwidth without loss in sensitivity in equipments already designed.

#### Design Objectives

For comparison purposes we may accept the 5JP as representative of a conventional type which might be chosen for use in a wide-band 'scope. This tube has deflection plate connections brought out through the neck wall, and has a post-deflection accelerating electrode. Typical operating voltages for this tube in a wide-band instrument for observation of repetitive signals would be  $E_{cc} = 2$  kv and  $E_{aa} = 4$  kv. For this condition the bogie deflection factors are 96 volts

per inch on both  $D_1$ ,  $D_2$ , and  $D_3$ ,  $D_4$  deflection plates. Hence, for a 3" scan a peak signal swing of about 288 volts would be required. As a prime objective to be considered in the design of an improved tube it was felt that the deflection factor of the  $D_1$ ,  $D_4$  signal plate pair should be reduced by a factor of at least one-third as compared to the 5JP, but that also the following restrictions should apply:

- (1) The spot size and focus of the improved tube should be comparable to the 5JP and other conventional 5" tubes, with approximately the same available current in the beam.
- (2) Capacities in the deflecting plate system should be kept low.
- (3) The upper frequency limit for 10% reduction in deflection factor due to transit time should not be below 200 megacycles.

Further, to permit recording of very high writing rates the post-accelerator features of the high-voltage type 5RP should be included in the new design.

#### The Design Solution

Discounting the restrictions and considering only the objective of decreasing deflection factors for a given cathode-ray tube, this might be achieved by any of the following methods:

- (1) The deflection plates to screen distance could be lengthened, which would decrease deflection factors by the ratio of plate-pair

to screen distance in the given tube, to plate-pair to screen distance in the lengthened tube.

- (2) The deflection plates could be made longer with a resultant increase in plate area and the capacities between plate pairs and to other electrodes in the gun.
- (3) The plates could be made to fit very close to the bundle of electrons forming the beam.
- (4) The plate design could be carried out to provide only sufficient scanning distance to make the tube useful; in other words, not necessarily full-screen scanning as is the case in conventional cathode-ray tubes.

Method 1, the lengthening of deflection plates to screen distance conflicts with restriction 1 for the reason that spot size for a given electron gun increases as the gun and focus lenses are mounted further from the screen. Since it was desirable to use conventional electron gun and tube dimensions, it was necessary to discard this approach.

Method 2, the increasing of plate length and area would have increased capacities to an extent which would partly nullify the advantages of lower deflection factors in simplifying deflection amplifier design.

Method 3 has limitations in that it was found, by experiment, to be extremely difficult to pass electron beams which have a diameter nearly equal to plate separation without distortion of the focused spot. Further, the alignment techniques required in construction of the gun and deflecting system became very critical.

Method 4, the limitation of scanning distance does not conflict with any of the three restrictions and may be justified since most commercial very-wide band 'scopes are already scan-limited, not from the cathode-ray tube standpoint, but from the limitation of overloading in the deflection amplifier with amplitudes above 2½" or 3" in the  $Y$  axis direction.

The final design of the new tube was a compromise between methods 2, 3, and 4, but the gain realized was primarily due to method 4, the limitation of scanning in the  $D_1$ ,  $D_4$  direction.

To further see why method 4 was so useful, a comparison between the con-



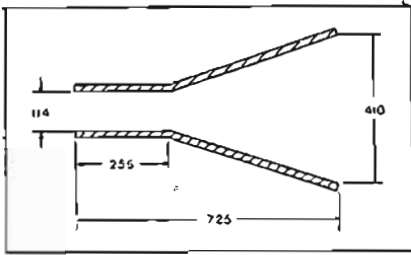
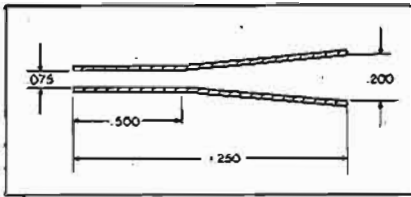
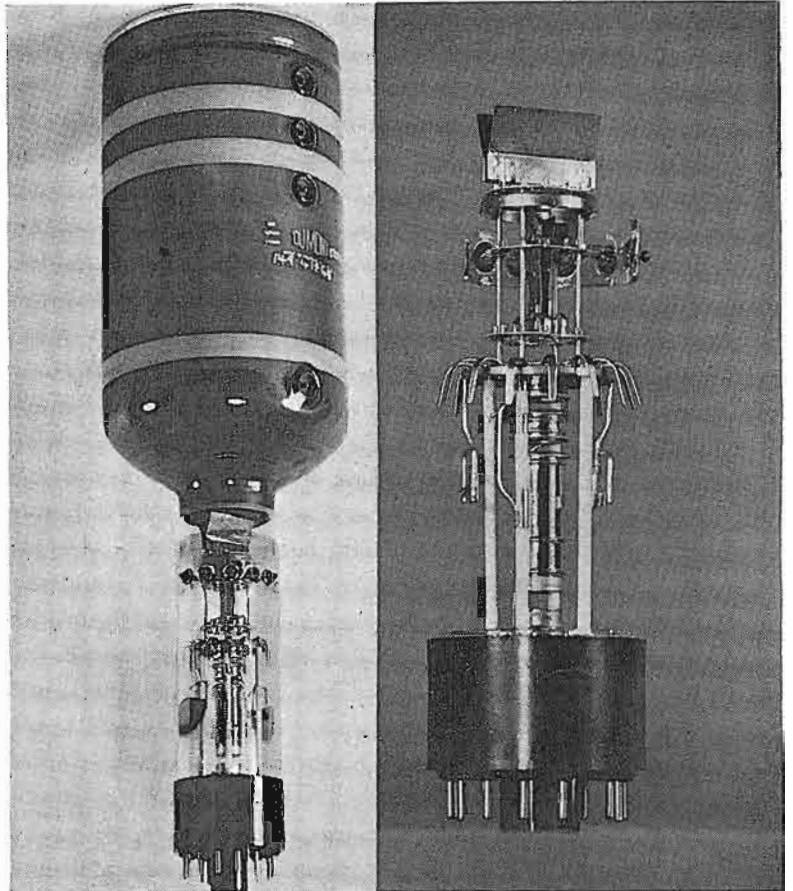

Figure 1  
Dimensions of conventional  $D_1D_2$  deflecting plates.

Figure 2  
Dimensions of the  $D_3D_4$  deflecting plates of the wide band *crt*.



Figures 3 (left) and 4 (right)  
At left appears a view of the 5XP cathode-ray tube. At right is the gun assembly of the tube.



ventional and the new design tube can be made. In the conventional tube large plate separation is necessary since full screen scanning is required and production tolerances on alignment must be accommodated. Considering only one set, the back  $D_3, D_4$  plates of a conventional tube are made as shown in Figure 1.

Such plates in a 5" tube normally scan an effective length of 6" to 7" without the beam being cut off by either the bend or the end of the plates. The plate width in such a structure is about  $\frac{3}{4}$ " to insure that a uniform deflecting field is formed, and that the fields of other electrodes do not interfere with the motion of the beam in the  $D_3, D_4$  region. Also for economy of manufacture the back set of plates are often identical to the front  $D_1, D_2$  pair, hence they are usually wider than necessary from field considerations.

In the new design, a plate structure of the dimensions shown in Figure 2 was achieved by design formulas. This set was designed to scan  $2\frac{3}{4}$ " of a 5" screen for an  $E_{b3}$  to  $E_{b4}$  ratio of 2.

Because the separation between plates was not over .200", it was possible to make the width of these plates less than conventional structures without fear of outside field interference. To further insure freedom from interaction between deflecting plate pairs,

an inter-plate pair shield was provided to isolate the front and rear sets of plates. In the final design the width of the  $D_3, D_4$  plates was reduced from  $\frac{3}{4}$ " as they are in a conventional tube to about  $\frac{3}{8}$ ". This change made possible a compensation for the increase in deflection plate capacities which would be expected from the increase in plate length and decrease of plate spacing. Sufficient compensation was achieved to make the capacities of the deflecting system approximately the same as those of a conventional *crt* with leads brought out through the glass neck, such as the types 5JP and 5RP.

The first *crt* design now being manufactured according to the principles outlined in this paper has been assigned the RMA type number 5XP (with suffix numbers to indicate screen types).

Physically the 5XP looks like the 5RP, the high voltage cylindrical body tube of 5" screen diameter. The 5XP has the same voltage ratings as the 5RP, although it is anticipated that many applications for the 5XP will be in the low and medium voltage range.

#### Performance of the 5XP

For the operating conditions of  $E_{b3} = 2 \text{ kv}$ ,  $E_{b4} = 4 \text{ kv}$  considered pre-

viously as typical for a wide-band 'scope for repetitive signal analysis, the bogie deflection factors for the 5XP and other conventional type tubes are:

Deflection Factors	5XP	5JP	5RP
$D_3, D_2$ dc volts/inch	90	96	90
$D_3, D_1$ dc volts/inch	30	96	90

Scanning distance for this operating condition is at least  $2\frac{1}{2}$ " in the  $Y$  or  $D_3, D_4$  direction and more than full screen in the  $X$  or  $D_1, D_2$  direction.

For a given  $E_{b3}$  value, the minimum useful  $D_3, D_4$  scanning distance is limited by the converging action of the post accelerating lenses according to the following table:

Ratio $E_{b3}/E_{b4}$	1	2	5
Minimum useful scan $D_3, D_2$	$4\frac{1}{4}$ "	$4\frac{1}{4}$ "	$4\frac{1}{4}$ "
Minimum useful scan $D_3, D_1$	$2\frac{3}{4}$ "	$2\frac{1}{2}$ "	$1\frac{3}{4}$ "

For 2,000-volt second-anode operation the upper frequency limit for the longer  $D_3, D_4$  plates has been calculated to be slightly over 200 mc for a 10% reduction in deflection sensitivity due to transit time. Hence, by appropriate design technique and a sacrifice of a portion of the  $Y$  axis scanning which is often of little value, it was possible, in effect, to obtain a voltage gain of

(Continued on page 30)



## TV / FM FIELD INTENSITY

To ESTABLISH the coverage of a TV or FM station, all holders of construction permits are required to submit a field intensity survey. While postponement of the actual time of submission, particularly with respect to FM has been made, in the not too distant future<sup>2</sup> each station will have to comply with this requirement.

From the Commission's standpoint these field intensity surveys serve several purposes: (1) It is evidence that the actual coverage of the station reasonably agrees with that proposed and which was theoretically determined. (2) It provides a basis for the allocation of other stations on the same and adjacent channels as the service contours which are to be protected have been established by actual measurement and not just theoretically determined. (3) It adds to the Commission's fund of propagation data enabling it to evolve more accurate allocation standards.

These are all very substantial reasons for issuing this requirement and are in the interest of the station as well as others. However, there are many other reasons which make the measurements much more valuable to the station, provided they are properly made and used. The measurements, when accurately made and properly analyzed, can be very helpful to the licensee. Since the primary purpose in operating a station is to provide a service to an area within which people reside, it is particularly important to render this service to as large an area and population as possible. The only way to note whether a station is pro-

ducing what it is capable of doing is to actually make measurements and then use these data as a basis for determining whether additional adjustments are required or even whether there is even some basic fault in the installation that might not be noticeable.

Very often we are prone to judge ourselves or our station operation by comparison with others. This is, of course, a very good practice but very often the other transmitter may be just as far off as we are. In fact, there are times when it will be decidedly to a station's advantage to have measurements made of the competitor's station, too.

There are three general methods which can be used to make field intensity surveys, with almost innumerable variations of each: (1) Airplane measurements; (2) spot or cluster measurements, and (3) running measurements.

The first, airplane measurements, while being very definitely of value in making special studies of the antenna performance, are not very adaptable for a complete proof-of-performance and it is doubtful whether they would be acceptable to the Commission. For obvious reasons it is not normally possible to make such measurements at a low enough level to be reasonably interpreted as to what the measurements mean with respect to service where the receivers are located. In spite of the advances made in aviation there is a

relatively small percentage of the audience of the normal station cruising around in an airplane. At some future date when sufficient measurements both in the air and on the ground have been made to establish a correlation, such airplane measurements may be the best answer. However, at present it is believed that airplane measurements can be considered as a type of special measurement.

Spot measurements or cluster measurements are measurements made at approximately uniform intervals along the radial. This is the same as the procedure normally followed in making Standard Broadcast Proof-of-Performance measurements, except that a greater number of measurements are made within a very short distance; that is, in a cluster so as to obtain an average figure. This method has the advantage of accurate following of a radial; by this method it is possible to leave the highways and make measurements in open fields and other places where an automobile cannot travel readily. On the other hand, this method has several disadvantages, the first being the human endurance limitations. It doesn't take many trips of 200 or 300 yards across a plowed field with the field intensity set, antenna system, and storage battery to make one decide that there must be some easier way of making the measurement. Second, although if sufficient measurements are taken in an immediate area an accurate average field intensity can be obtained, unless the cluster measurement areas along the radial are at very close intervals, it is difficult to obtain

<sup>2</sup> The late summer will probably see the rule in effect.





Another type of field car with a simple dipole antenna installed.



Rear view of interior of field car illustrating the portable test and measuring gear.

## MEASUREMENTS\*

**Essential Equipment and Methods Used in Actual Field-Measurement Operations For TV and FM Stations Lucidly Described by Former FCC Chief Engineer.**

by **GEORGE P. ADAIR**

Consulting Engineer and Consultant Adviser  
NAB Engineering Executive Committee

any true representation of what is happening due to the large and rapid variations encountered. This method is considerably slower in making field intensity measurements. However, it is much easier to analyze, but less accurate and affords less complete information than running measurements.

Running or mobile measurements are made by mounting the field intensity set and associated equipment in a vehicle so as to make measurements, while running along a highway as close to a radial as is possible. (In the original engineering report accompanying the application, radials which lie along roads as nearly as possible should be selected.) It is usual during these running measurements to mount the antenna above the vehicle, 10' above the ground. These readings must be converted to a height of 30', by multiplying by the factor, 3. The output of the field intensity meter is

\*From a paper presented at the Third Annual NAB Broadcast Engineering Conference.

connected to a recording milliammeter on which the clock drive to the tape has been disconnected and the tape drive connected through appropriate gears to the speedometer drive. The gearing ratio should be such that the speed of the tape is from 6" to 8" per mile. If the speed of the tape is much greater than this, the work required in analyzing the charts will be increased, and if it is much less a true indication of the variations in field strength cannot be obtained.

### 600-mc Measurements

An interesting measurement method has been used in San Francisco on 600 mc on experimental TV station, W6XJD. In this method we have attempted to correlate measurements made on the ground with field intensities that can be expected at various locations within a building or on top of it. This work has not been completed. However, the preliminary results are encouraging. This correla-

tion, of course, depends on many factors including the frequency, building, and surrounding buildings.

In making these measurements with mobile recording equipment a run is made around the block within which is the building under study. Measurements are then made at several points about the building on all sides, and then within the building at numerous locations, and on top of the building at points where an antenna might be installed. It is believed that after making a great number of such tests, a reasonably accurate prediction can be made of the signal which can be expected to be obtained, either when using an indoor antenna or one on the roof, for running measurements made in the streets around the building. This information should be valuable not only to the station but to receiver dealers.

In making spot measurements the essential equipment consists of an antenna and a field-intensity meter. For mobile or running measurements there must be added a recording milliammeter driven from the speedometer drive. A clock drive may be used. However, it is considerably more difficult to mark sufficient points on the tape to permit analysis and much more difficult to analyze, as well as probably obtaining a less dependable result. In addition to this basic equipment, several other items have been found very useful, in facilitating measurement operations and also in improving the results.

These, briefly, are a desk or table, typewriter, altimeter, thermometer, automobile-type compass, watch, hygrometer, and last but not least, a place to hang coats.

The desk or table is a firm support for the equipment and a comfortable



and convenient place to keep the log or do other work. Keeping the log by typewriter has proven most helpful, providing a log which can be read. The altimeter is helpful in that if readings are taken and logged they will often assist in analyzing the data, particularly where good topographic maps are not available. Since this instrument works from barometric pressure considerable discretion must be exercised in its use. The thermometer and hygrometer are helpful where tropospheric propagation is a material factor and studies in this regard are desired. The compass is often required in orienting the antenna while moving and also in finding where you are at times. The watch answers for itself. None of these items are of much value unless readings are taken and recorded on the log.

The Commission's standards require that measurements be made with an antenna which is non-directional in the horizontal plane. They will permit the use of a dipole antenna, if authority is obtained to do so before making the measurements. The simple dipole has been found about as good as anything, particularly since this is the type of antenna used with most receivers. It can be used either of two ways: (1) Orienting its maximum towards the station at all times, or (2) determining the field pattern and making appropriate adjustment in analysis of the recordings.

In making field measurements, tropospheric effects must be carefully considered. In general, tropospheric propagation tends to extend the service range. This phenomena is generally much more in evidence in the afternoon and evening, than in the forenoon. Therefore, to obtain the best picture of the actual operation of the transmitter, measurements should be made in the morning, going as far out on the radial as it is planned to make measurements, and making them on the return trip and timing it so that the measurements for each radial are for as nearly the same time of the day as possible. Analysis will be facilitated and the accuracy improved by maintaining as steady speed as possible while recording. About 15 miles per hour in cities and 30 miles per hour in the country have been found to be reasonable speeds which can be maintained fairly constantly.

#### Calibration

There are several methods which can be used for antenna calibration and pattern determination. One of the most popular involves a turntable for



Coax antenna with reflector used in field measuring tests.

the vehicle and a transmitter located at a specified distance. However, due to the standing-wave effect, the accuracy cannot always be assured. One method has been found to give particularly good results. In this method, it is first necessary to find an area some 200' or 300' diameter which meets five general requirements: (1) essentially level; (2) surface sufficiently hard so as it can be driven over; (3) at sufficient distance from the station so that the signal comes from substantially a point source even considering reflections from subjects near the station; (4) free from reflections from nearby objects; and (5) line-of-sight from the transmitter.

When such an area has been found, a point near the center is marked. From this center point cords are stretched out about 100' at least every 45° and preferably every 22.5° with the zero bearing being towards the station.

The field-intensity set and recording milliammeter are taken from the car and set up with the car removed some distance so as not to affect the readings. The dipole antenna is then carefully adjusted for the frequency and mounted so as to be 10' above the ground and movable with a protractor arrangement at the bottom of the supporting pole to determine the orientation. The clock movement of the recorder is connected using the highest speed. With the dipole oriented directly towards the station, the antenna is moved at a steady rate along the cord marking the direction of the station to the limit of the cable connecting the antenna to the field intensity set.

On one unit the standard cable is of a length sufficient to permit a movement of approximately 10' each way from center, or a total of 20'. The antenna is oriented to the next bearing and the procedure repeated. When all

bearings have been run in this manner, a plot of the average of each run will give the pattern of the dipole. The equipment is again mounted in the car and runs made on the same bearings, but for 200'. In the event it is planned to rotate the antenna to keep it oriented on the station while running a radial, the process should be repeated for each orientation to make certain that any effects due to the car are eliminated. The average of each of these runs should then be plotted. These compared to the pattern obtained on the dipole will give a calibration of the antenna installation. By use of this method the maximums and minimums that occur every half wavelength are averaged out, giving a truer calibration than can be obtained by merely rotating the antenna or complete installation. This type of calibration also more closely matches the recordings that are obtained when actually running a radial, as the time constant of the recorder is too long to follow the half wavelength variations.

After the measurements have been taken, which normally require about 800 to 1,000 miles driving and two weeks' time, the real job appears—analyzing the data and preparing it for presentation. This requires about ninety man days' time to do a good job. Much of this time is required to determine the medium field; that is, the field exceeded for 50% of the distance. Generally this requires a trial and error determination by one means or another. The simplest hand method is by the use of a pair of dividers or a slide rule with a pointer attachment, to add up the distance that the signal was above a value selected by inspection. If this guess proves in error another value is selected and the process repeated. A little practice develops considerable skill in selecting trial values, so that usually 2 or 3 trials are adequate.

Regardless of how tedious the measurement work may be, it is most important to be accurate and consistent throughout. While obtaining the data, notations as to unusual or unexpected effects should be entered on the log. The analysis may bring out some discrepancies or apparent discrepancies which were not noted before. Reference to altimeter or compass readings may give valuable clues or reasons for adjustments or corrections.

The more accurate and fully the data compiled and analyzed, it is realized the more expensive will be the job. But unless it is accurate, there

(Continued on page 31)

F.R.C.A. WX-1A (formerly Clarke 106-B)





# GIVES YOU PERSON-TO-PERSON HELP WITH YOUR MEASURING PROBLEMS

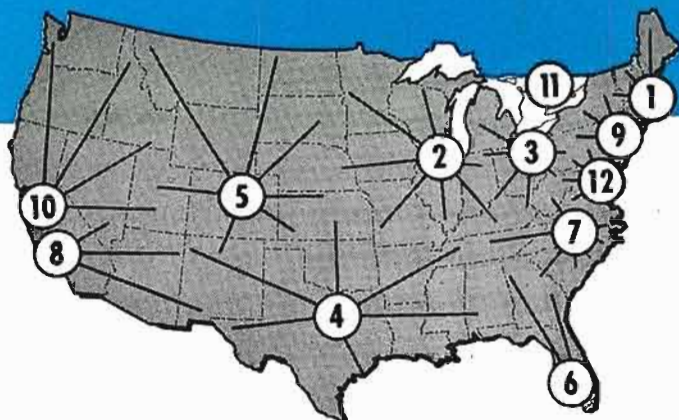

**-hp-** has selected the best independent organizations in America to provide you with personal attention to your measuring problems. Their technical men have complete information about **-hp-** instruments and can help you select the correct measuring equipment for your needs. The **-hp-** direct-to-consumer sales policy saves you money, and the **-hp-** field service program saves your time. Whenever or *wherever* you need personal help on measuring problems, call the nearest **-hp-** field representative.

- |   |   |
|---|---|
| <p><b>1 BOSTON, MASS.</b><br/>Burlingame Associates<br/>270 Commonwealth Avenue<br/>Kenmore 6-8100</p>      | <p><b>7 HIGH POINT, N. C.</b><br/>Bivins &amp; Caldwell<br/>Room 807, Security Bank Building<br/>Phone 3672</p>   |
| <p><b>2 CHICAGO 6, ILL.</b><br/>Alfred Crossley &amp; Associates<br/>549 W. Randolph St.<br/>State 7444</p> | <p><b>8 LOS ANGELES 46, CALIF.</b><br/>Norman B. Neely Enterprises<br/>7422 Melrose Avenue<br/>Whitney 1147</p>   |
| <p><b>3 CLEVELAND 12, OHIO</b><br/>M. P. Odell<br/>1748 Northfield Avenue<br/>Potomac 6960</p>              | <p><b>9 NEW YORK 7, NEW YORK</b><br/>Burlingame Associates<br/>11 Park Place<br/>Digby 9-1240</p>                 |
| <p><b>4 DALLAS 5, TEXAS</b><br/>Earl W. Lipscomb<br/>4433 Stanford Street<br/>Logan 6-5097</p>              | <p><b>10 SAN FRANCISCO 3, CALIF.</b><br/>Norman B. Neely Enterprises<br/>954 Howard Street<br/>Douglas 2-2609</p> |
| <p><b>5 DENVER 10, COLORADO</b><br/>Ronald G. Bowen<br/>1896 So. Humboldt Street<br/>Spruce 9368</p>        | <p><b>11 TORONTO 1, CANADA</b><br/>Atlas Radio Corporation, Ltd.<br/>560 King Street West<br/>Waverley 4761</p>   |
| <p><b>6 FORT MYERS, FLORIDA</b><br/>Arthur Lynch and Associates<br/>P. O. Box 466<br/>Fort Myers 1269M</p>  | <p><b>12 WASHINGTON 9, D. C.</b><br/>Burlingame Associates<br/>2017 S Street N.W.<br/>Decatur 8111</p>            |

This **-hp-** staff of trained specialists is the largest organization of its kind in the world.

## NEW, HIGH SENSITIVITY, WIDE RANGE VOLTMETER



### **-hp-** 400C Voltmeter

This new **-hp-** voltmeter makes fast, accurate readings from .1 mv to 300 v., 20 cps to 2 mc. Voltage range 3,000,000 to 1. Panel switch selects 12 ranges. Input impedance 10 megohms.

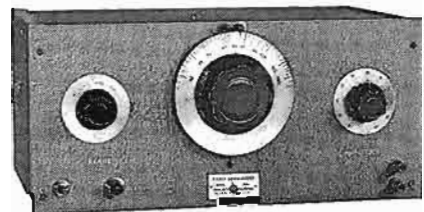

### **-hp-** 200C Oscillator

One of 5 basic **-hp-** audio oscillators. **-hp-** 200C covers frequency range of 20 cps to 200 kc. Constant output, low distortion, great stability. No zero setting necessary during operation.

**For complete details, write direct or see your -hp- representative.**

## HEWLETT-PACKARD CO.

1851-E Page Mill Road, Palo Alto, California

Export Agents: Frozar & Hansen, Ltd.  
301 Clay Street • San Francisco, Calif., U. S. A.

**hp laboratory instruments**  
FOR SPEED AND ACCURACY



# This new 5-kw FM Transmitter

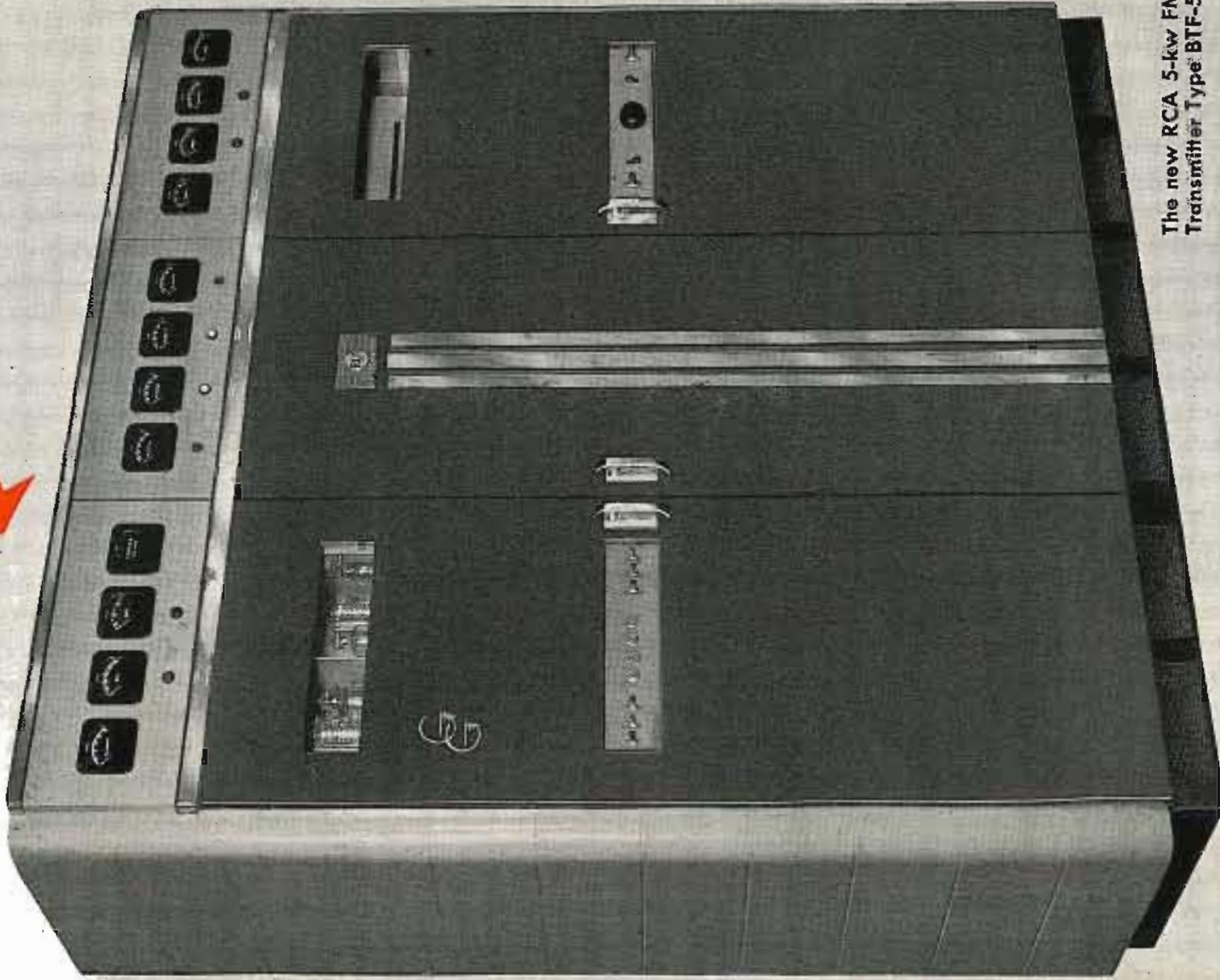

The new RCA 5-kw FM Broadcast Transmitter Type BTF-5A



**BROADCAST EQUIPMENT**

**RADIO CORPORATION OF AMERICA**  
**ENGINEERING PRODUCTS DEPARTMENT, CAMDEN, N. J.**

In Canada: R. A. VICTOR Company Limited, Montreal



# -and a 4-section Pylon

*plus*  
**gives you 20 kw ERP**  
**... Economically**

● For the broadcaster with an FM grant for 20 kilowatts, effective radiated power, this new transmitter . . . in combination with an RCA 4-section Pylon . . . *solves the problem economically.*

Here is the reason: a 4-section Pylon with a power gain of 6, steps-up the 5 kw to 30 kw (ERP) . . . allowing plenty of reserve power. This eliminates the costly choice of using either an expensive high-gain antenna structure with a low-power transmitter—or a higher power and more expensive transmitter with a conventional low-gain antenna.

Like all RCA's well-known FM transmitters, the BTF-5A uses RCA "Direct FM"—inherently capable of holding distortion and noise to extremely low levels. RCA power-saving Grounded-Grid circuits in the driver and final are designed to use the new RCA-5762 heavy-duty triodes. Both amplifiers require no neutralizing, are simple to tune, and are more stable than older and more conventional types. Type BTF-5A uses only 37 tubes and only 14 tube types. *Of these 37 tubes, only 21 tubes are required for emergency operation.*

All air-cooled, this transmitter includes every proved feature needed for efficient operation. It uses no trick circuits or gadgets—and it is simple to handle (inexperienced personnel can learn to run it in minutes). Unit construction makes the 5-kw FM transmitter easy to install. And if you now have an RCA 3-kw FM transmitter you can easily increase power to 5 kw by adding a simple conversion kit—now available.

For complete data on how this transmitter can radiate *from 20 to 60 kilowatts* of effective radiated power—and for information on the 5-kw conversion kit—see your RCA Broadcast Sales Engineer. Or write Dept. 23E, RCA Engineering Products, Camden, N. J.

*Quick-Selection Chart for RCA Pylon Antennas  
 (Choose the type for power gain needed)*

STANDARD PYLONS				
RCA 5-kw FM Transmitter	RCA Pylon Antenna			Maximum Effective Radiated Power
	Type	Gain	No. Sections	
BTF-5A	BF-11 A/B	1.5	1	7.5 kw
BTF-5A	BF-12 A/B	3	2	15 kw
BTF-5A	BF-14 A/B	6	4	30 kw
BTF-5A	BF-18 A/B	12	8	60 kw
HEAVY-DUTY PYLONS				
BTF-5A	BF-12 E/F	3	2	15 kw
BTF-5A	BF-14 C/D	6	4	30 kw

RCA 4-section Pylon delivers up to 30 kw (E. R. P.) with the BTF-5A transmitter!

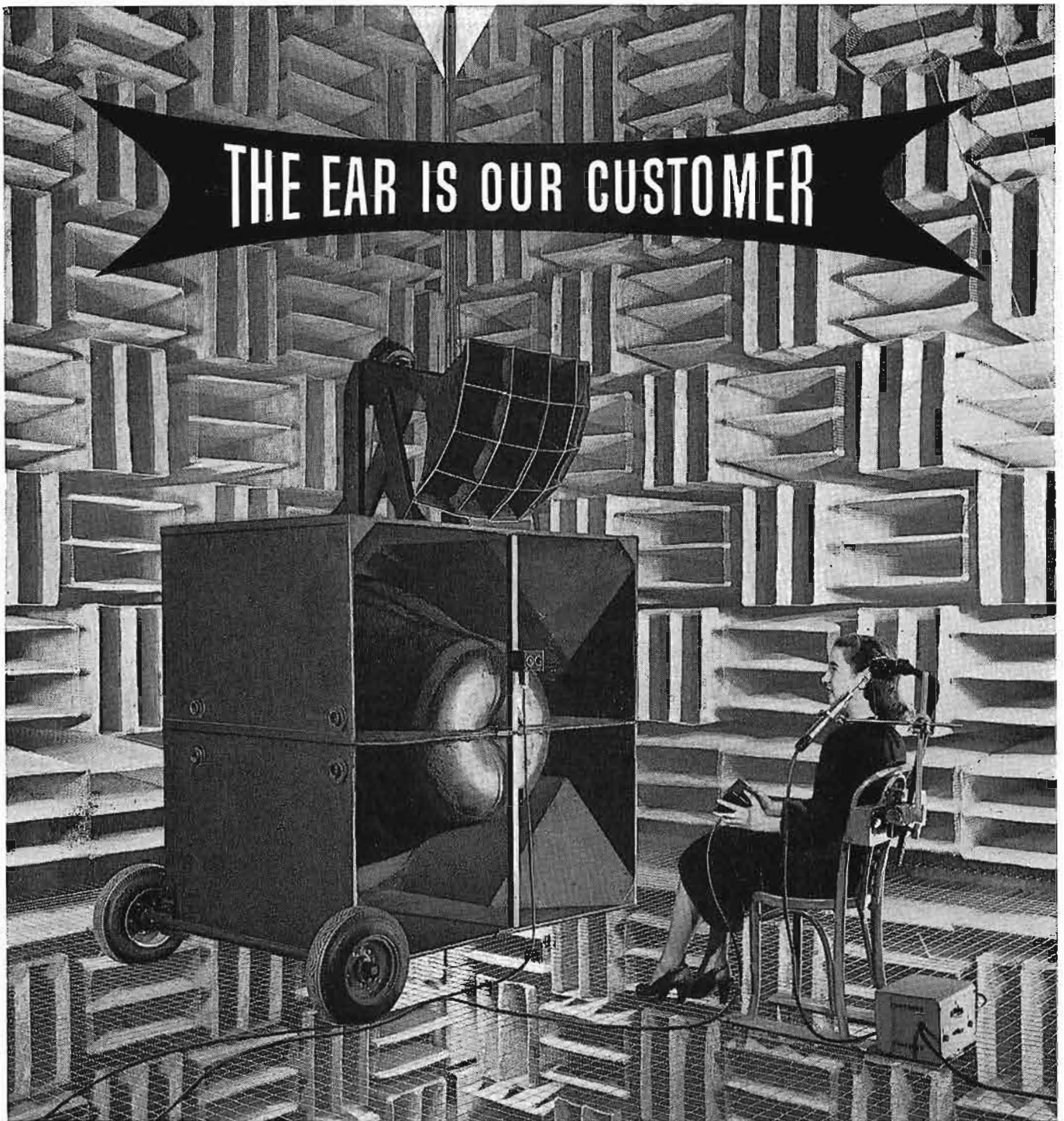

What happens when you hear? What happens *inside* your ear when sound waves come in from a telephone conversation?

Bell Telephone Laboratories scientists have developed special apparatus to help answer these questions, for the telephone system is designed to meet the ear's requirements for good listening.

In the test pictured above, the young lady sits before loudspeakers in a soundproofed room with a small hollow tube, reaching just inside the ear canal. Sounds differing slightly in frequency and intensity come from a loudspeaker. The subject seeks to tell one from another, recording her judgment electrically by pressing a switch.

Meanwhile, the same sound waves pass down the hollow tube to a condenser microphone, and a record is made of the exact sound intensities she identified. Results help reveal the sound levels you can hear clearly and without strain—the sounds your telephone must be designed to carry.

Scientists at Bell Telephone Laboratories make hundreds of tests in this manner. It's just one part of the work which goes on year after year at the Laboratories to help keep Bell System telephone service the finest on earth.

## BELL TELEPHONE LABORATORIES

Exploring and inventing, devising and perfecting, for continued improvements and economies in telephone service.





# A Visit to WOR-TV



The picture, sound and FM transmitter control desk of WOR-TV, with F. J. Bingley, chief television engineer for WOR-TV and WOR's Washington, D. C., television station, WOIC, at the controls. At the desk (standing), left to right, are J. R. Poppo, vice president of WOR in charge of engineering and Charles H. Singer, WOR's assistant chief engineer.

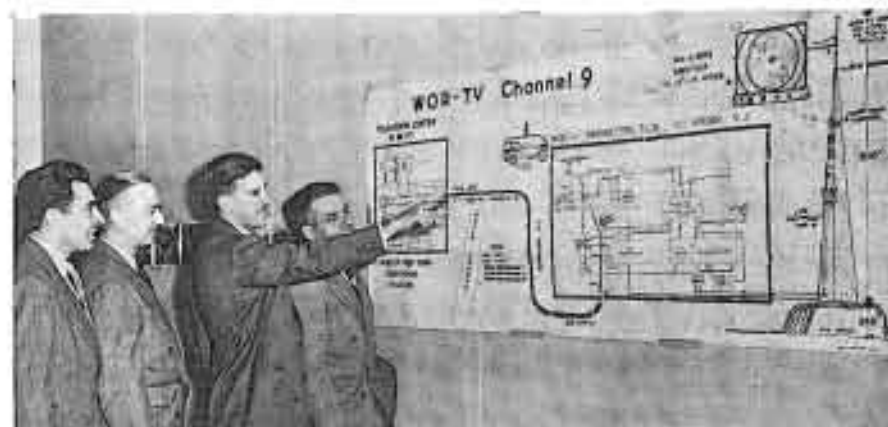

Four members of the WOR-TV and WOR engineering staffs studying a pictorial facilities schematic of the transmitter building: Francis Geruly, Edmund Franko, George Riley and R. H. Davis.

*Jobny On The Spot.* WOR's mobile studio which has undergone a face-lifting operation and emerged as a TV television car. Field car is now equipped with three field cameras, a microwave transmitter, camera control units, four video picture monitors and equipment for switching pictures from one camera to another. In addition, the unit houses a radiotelephone and complete equipment for AM broadcasting. Television camera mounted on the roof is being operated by R. H. Davis of WOR-TV.



THE PALISADES of New Jersey, on the banks of the Hudson River, where the historic FM broadcasts were begun by Major Armstrong, will be in the late summer, the scene of another outstanding event in broadcasting, when WOR-TV begins telecasting on channel nine, via the highest steel tower in the East, 1,050' above sea level.

The tower, rising 760' above the ground, will be topped by a fifty-foot pole, with a six-bay batwing and single-bay FM antenna. This tall structure, which will weigh more than three-quarters of a million pounds, will be sufficiently strong enough to withstand winds up to 120 miles an hour.

## Relay Provisions

Two-thirds of the way up the tower, at the 555' level, will be a glass enclosed microwave relay station. Two copper coax lines, each  $3\frac{1}{8}$ " in diameter, will be carried to the tower's top for TV and another line will be mounted alongside for FM broadcasting. For electrical distribution there'll be twelve conduits each  $1\frac{1}{2}$ " in diameter.

As a safety precaution against falling ice and to protect the antenna against freezing, each antenna bay will be equipped with a caloroid resistor.

The transmitter building, a one-story brick and glass structure with 5,000 square feet of floor space, will serve as a home for not only the transmitter, but a complete machine shop, kitchen and three-car garage for the station's mobile units.

## The Transmitters

WOR-TV will use a 5-kw video transmitter<sup>1</sup> and 2 $\frac{1}{2}$ -kw sound transmitter,<sup>2</sup> the output of which will be combined in a diplexer unit.

The building will also house a utility room which will have blowers and a water-cooler setup for the transmitter and the building's air-conditioning system. During the winter the building will be heated by the warmth of the transmitter tubes, thereby providing its own heating system.

A comprehensive discussion of all of the facilities of WOR-TV is now being prepared and will appear in an early issue of COMMUNICATIONS. Watch for this issue.

<sup>1</sup>AG. E. type 6B visual transmitter.  
<sup>2</sup>AG. E. type 6B aural transmitter.



# Balanced 2-Wire Method to

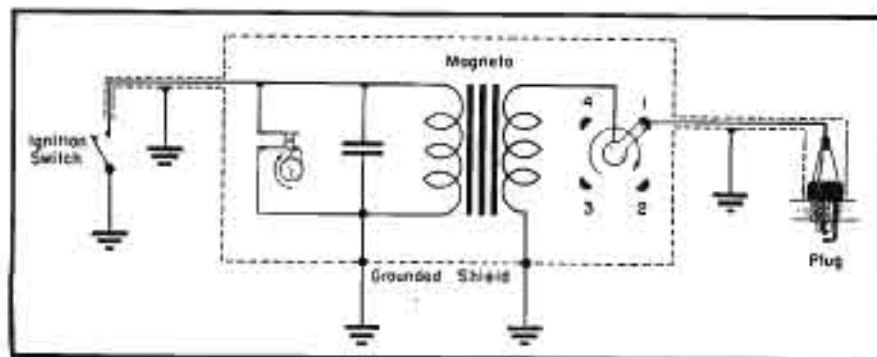

Figure 1  
Conventional single-wire ignition system using a magneto.

Two methods for the elimination of ignition interference are in common use. Both of these methods have shortcomings and neither has proved to be a wholly adequate solution.

In one method we have the suppressor resistor used to minimize radio interference to a sufficient degree for non-critical applications. A typical application is in connection with the use of automobile receivers for entertainment. This is an inexpensive approach, but it has the disadvantage of a detrimental effect on engine performance.

Shielding the ignition system is the second method which is used for more critical applications. A typical example is a plane equipped with communication and navigational apparatus. Here the greatest possible noise suppression is desired and engine performance must not be affected. A shielded ignition system provides adequate noise suppression when it is in proper working order, but it is difficult to maintain it in that condition when it is subjected to extreme temperature changes, moisture, dirt, oil, vibration, and corrosion.

Because of the increasing use of

radio equipment in vehicles other means of reducing ignition interference were explored recently.

## Conventional Shielded System

In Figure 1 appears a conventional shielded ignition system. To facilitate studying the operation of this particular type of interference-reducing system, the shielded connections to the spark plug can be assumed to be like concentric lines. With such an arrangement, *rf* currents flowing in one direction on the inner conductor are matched by equal currents flowing in the opposite direction on the shield. Radiation of interference does not take place from such a system because the shield current flows on the inner surface of the shield. However, a bad joint in the shield can upset this arrangement, as we note in Figure 2.

In this illustration a bad joint in the shielding is represented by a simple resistance, *R*. When ignition current is flowing, a voltage, *E*, appears across this resistance. As a result, a portion of the shield current will flow outside the shield. Serious interference results even if this portion is but a small

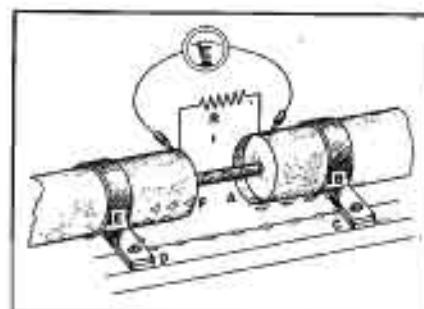

Figure 2  
Alternate current patterns which appear around a bad joint and result in the radiation of noise.

fraction of the total ignition current. The magnitude of the problem is indicated when it is remembered that modern multi-engine airplanes employ dozens of spark plugs, each of which is provided with threaded fittings in the shield. One bad connection in the shielding is enough to cause serious radio interference.

## Balanced Two Wire System

Since the concentric line is subject to mechanical difficulties, it becomes obvious that a balanced two-wire line could provide greater interference control. The diagram of such a system appears in Figure 3. The spark plug has two electrodes, each of which is insulated from ground, the distributor has two arms instead of one, and the high-voltage winding is center-tapped, with the tap grounded. If symmetry is preserved throughout such a balanced system, radiation will be very low since current in one wire is matched at every point by an equal and opposite current in the other wire. Some radiation does take place because of the spacing of the wires that make up the two-wire line. However, radiation is effectively suppressed for all wavelengths that are very long compared to the spacing of the wires, particularly if the wires are twisted together throughout their length.

## Breadboard Test

Model T Ford spark coils were known to have high-voltage windings wound in two symmetrical halves and afforded a ready means of obtaining experimental verification of 2-wire idea. Accordingly, two such coils were obtained, removed from their cases, and stripped of their protective coating. The primaries were connected

Figure 3  
A balanced two-wire ignition system. In this setup the primary circuit of the magneto is also balanced.

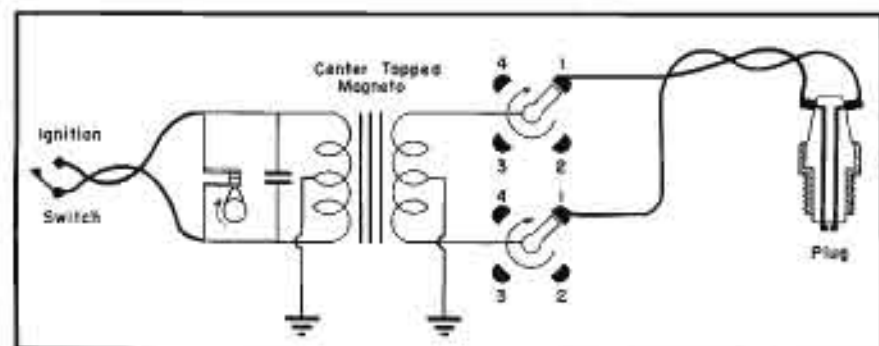



# Reduce Ignition Interference

to a battery and hand-cranked breaker points, through a switch, that allowed selection of the coil to be energized. The secondary of one was connected in a manner simulating a conventional unshielded ignition system. The secondary of the other coil was connected in a manner simulating a balanced two-wire ignition system. Radio receivers and noise-measuring equipment were set up nearby to obtain a comparison of interference. A plot of the reduction of noise achieved by the use of a balanced two-wire system over a conventional, unshielded system, appears in Figure 4.

The effectiveness of the balanced system was found to decrease as the frequency was increased. The electrical spacing of the wires expressed in terms of wavelengths increased as the frequency increased and was one contributing factor. The other factor was lack of perfect symmetry which became more serious as the frequency was increased.

It was discovered during these tests that the common type of distributor was not suitable for a balanced system. The distributor arm is customarily made too short to reach the contacts connecting to the spark plug leads. Consequently, a spark appears in the distributor each time a plug is fired. The balanced two-wire system is not symmetrical with respect to this spark, which is a noise source, and it is not surprising that noise resulted from its presence. The situation is not saved by the presence of similar gaps in each line, since the gaps are sufficiently unlike to prevent breakdown at identical instants. Thus the *rf* components of the ignition current are not equal and 180° out of phase in the two lines, resulting in interference.

## Experimental Aircraft Magneto

The next step was to design a working system to evaluate performance in a potential application. Examination of the performance of the simulated system led to the possibility of using the balanced two-wire system for privately-owned aircraft. Reception in such aircraft is normally limited to the low-frequency range and broadcast frequencies. Here the system could perform well and might offer cost savings that would be appealing. To explore this possibility, a magneto for a four-cylinder aircraft engine was obtained and rewound with the high tension coil arranged in two symmetrical

---

**Developmental Study Reveals That 2-Wire Method Is Superior to Suppressor or Shielding Procedures, When Symmetry Is Preserved. Radiation Found Very Low Since Current in One Wire Is Matched at Every Point by an Equal and Opposite Current in the Other Wire.**

---

by **V. WELGE**

Chief, Radio and Electrical Laboratories  
Consolidated Vultee Aircraft Corp.

halves. The distributor was replaced with a two-arm distributor of a roller type to avoid the jump-gaps previously found to be unsatisfactory in tests of the simulated system.

The completed magneto, shown in Figure 5, was given a shakedown test consisting of spinning for an hour in a drill press. Noise tests, measuring interference as compared with an unmodified magneto, yielded data similar to Figure 4.

The successful procurement of special two-electrode spark plugs (Figure 6) provided the remaining elements of an experimental system. An airplane equipped with a four-cylinder, 85-horsepower engine was obtained for tests of the system in an actual installation. The dual-ignition system on the engine was unshielded and our plan involved replacement of one of the ignition systems with the experimental two-wire system. The primary wiring

Figure 4

A plot illustrating the noise reduction achieved in 2-wire tests.

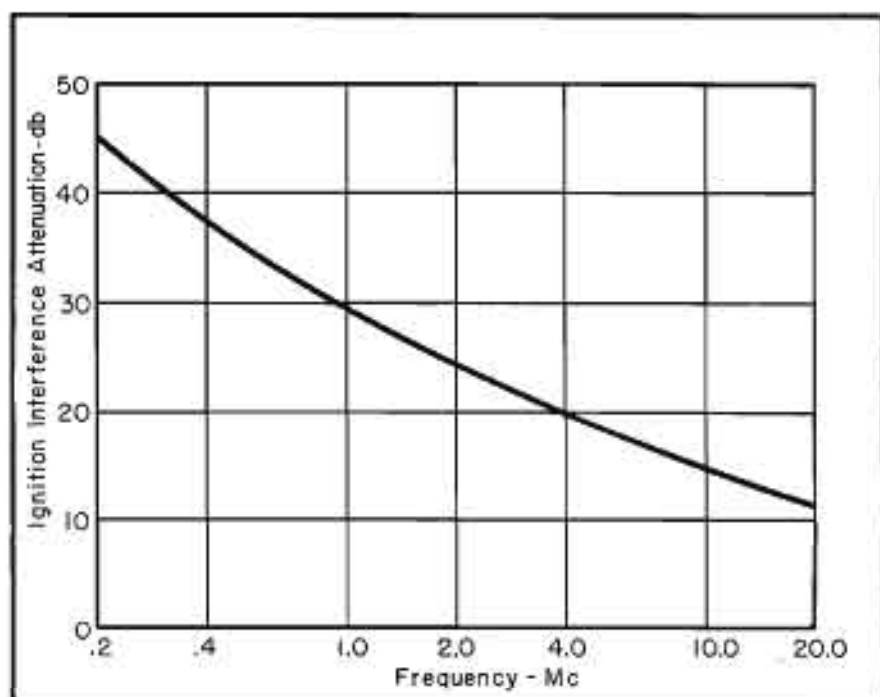

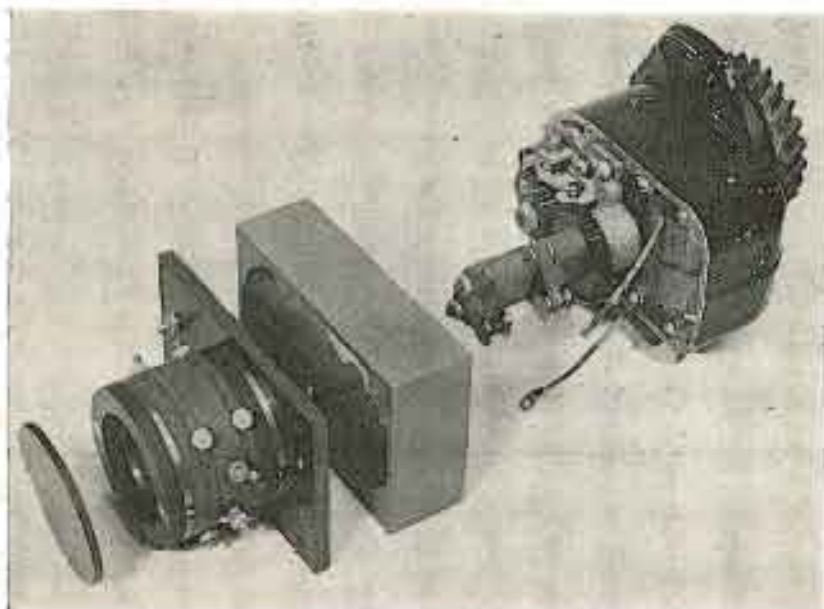

Figure 5  
Exploded view of the experimental balanced-line magneto.

of both magnetos was shielded and the electrical system of the airplane was switched off to prevent these possible noise sources from influencing the observations.

#### Results of Airplane Tests

The testing procedure consisted of engine run-up on the ground and switching from one magneto system to the other. Noise comparison was made by listening to an aircraft receiver<sup>1</sup> installed in the 'plane and by measurements of the receiver output noise level by means of an output meter.

Good qualitative results were obtained. Interference was present, when the balanced system was in use, but was suppressed sufficiently to permit the copying of weak signals that were completely smothered by the conventional magneto system. Quantitatively, the comparison did not place the balanced system in as favorable a light as the earlier bench tests. A maximum improvement of 20 db over the conventional unshielded system was recorded. However, much of this disagreement could be accounted for because of the use of peak-reading type

meters in the bench tests which were capable of more realistic measurement of ignition pulse noise.

Trouble was experienced with the experimental magneto in that sparking occurred between the rollers and contacts. Starting with a clean distributor, only occasional flashes would be seen at first. Each spark would contribute some blackening of the contacts and the frequency of sparking would steadily increase. Engine performance was not affected by this difficulty, but each time a spark took place in the distributor a heavy crash of interference would be picked up by the receiver. No difficulty of this kind was experienced during drill-press tests of the magneto. The conclusion drawn was that engine vibration was causing the rollers to occasionally bounce off the contacts, initiating sparking, and ending with a dirty distributor that was of no value insofar as radio interference was concerned.

Inasmuch as the balanced system was consistently reliable during ground tests and ran the engine as well as the normal system, two flights were made while this system was installed. Com-

Figure 6  
Two-electrode spark plugs used in 'plane tests.



parisons were again made when a safe altitude had been reached. No differences from the ground tests were observed except that less trouble was experienced with the vibration difficulties in flight.

#### Possible Additional Tests

Additional tests that suggested themselves during the course of the airplane studies included:

- (1) Measurement of peak accelerations experienced by magnetos arising from engine vibration.
- (2) Roller assembly modification to obtain greater spring pressure.
- (3) Use of peak-reading noise meters to obtain better correlation with the bench tests.
- (4) Improvement of the system balance by component modification or by compensation.
- (5) Use of lossy wire insulation to assist in the suppression of high frequency noise components.

These tests, and others, were considered unnecessary since the original purpose of this program, a practical demonstration of the principle, had been served.

#### Applications

Further research and component development are necessary to evaluate this idea properly. The ability of the distributor and spark plugs to give long-time, trouble-free service insofar as radio interference and engine performance is respectively concerned,

(Continued on page 31)

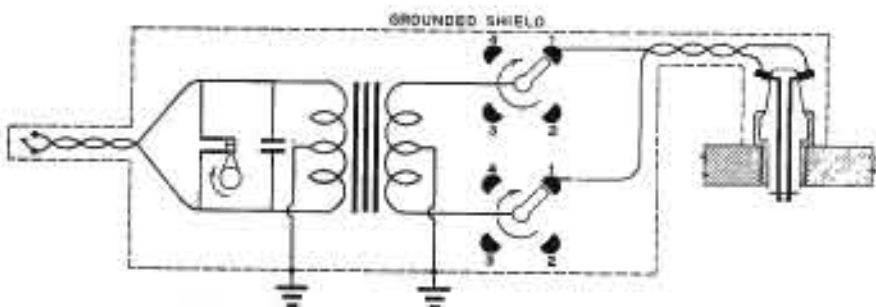

Figure 7  
Shielded two-wire system.

<sup>1</sup>Bendix PATR-III Flightphone.





## NOW AVAILABLE THE FIRST PRACTICAL BOOK

ON THE INSTALLING OF TV and FM RECEIVER ANTENNAS

# TV...FM ANTENNA INSTALLATION

by **IRA KAMEN**  
Manager, Television Antenna Dept.  
Commercial Radio Sound Corp.

and **LEWIS WINNER**  
Editor, SERVICE and  
COMMUNICATIONS

Over 35,000 words of practical information, with more than 130 photographs and drawings covering every conceivable type of installation, based on actual experiences in the field. Topics covered include...

### Antenna Tools

(Basic Tools Required . . . Application of the Correct Tools for Specific Types of Installations, Involving Flat-top Roofs, Slate Roofs, Tile Roofs, Chimneys, Etc.)

### The TV Antenna Installation Problem

(Fundamentals of All TV Installations . . . Judging Specific Application Features of the Various Types of Antennas Which Can Be Used for TV Work . . . Solving Reflection Problems . . . Improving Signal-to-Noise Ratio.)

### Solving the Problems of 12-Channel Reception

(Factors With Which Service Men Must Be Familiar to Accurately Install Antennas For Full-Band Coverage . . . Typical Problems Analyzed.)

### High Frequency TV Antenna Installations

(Antennas and Installation Procedures Which Afford Best Results, Solving Major Installation Problems Involving Tuned Indoor and Outdoor Antennas, Application of Stub Filters.)

### TV Interference

(Analysis of Nine Sources of Interference and Solutions Which Have Proved Effective.)

### Fringe Reception

(Selecting and Installing Antennas for Maximum Reception in Areas Over 45 Miles From Stations . . . Tower Installations . . . Estimating Tower Costs.)

### TV Master Antenna Systems

(Typical Multiple Dwelling Antenna Systems for Simultaneous Operation of Many Receivers From a Single Antenna Array and Amplifier Setup.)

### FM Antennas

(Analysis of Practical FM Antennas . . . Selecting Proper Antenna for Rural and Urban Jobs.)

### The Business of TV Antenna Installations

(How to Conduct Successfully TV Installation and Service Work Today . . . Proper Use of Correct Types of Installation and Servicing Agreements and Warranties.)

### TV Antenna Tricks of the Trade

(Antenna Installation Devices Which Will Improve Picture Fidelity.)

(Indexed for Quick Reference)

**BRYAN DAVIS PUBLISHING CO., INC., Book Dept.**  
52 Vanderbilt Avenue, New York 17, N. Y.

Send me a copy of TV . . . FM Antenna Installation, post-paid, for which I am enclosing \$2.00.

(Please Print)

NAME .....

ADDRESS .....

CITY AND STATE .....

AT YOUR JOBBER  
OR ORDER DIRECT



**Price \$2 Post Paid**

# How is YOUR company doing in this "EVERYBODY-BENEFITS" plan?

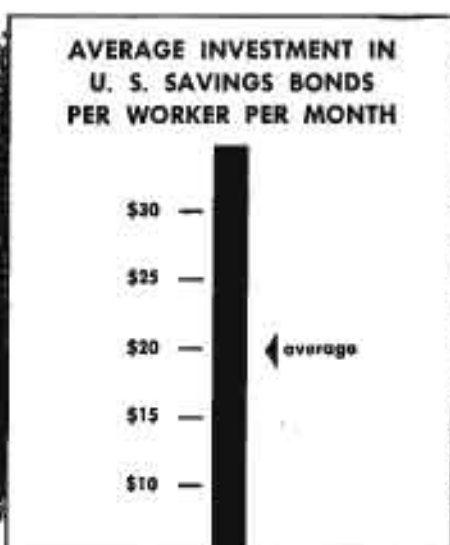
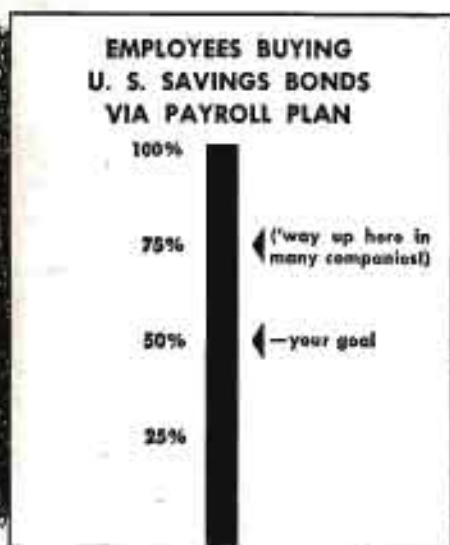

## Compare your employee participation with others who have Payroll Savings

If the figures for your company fall below those shown above, you're missing your share of benefits of the Payroll Savings Plan! These benefits are described below. Nation-wide experience proves that when top management puts the "OK" on the Plan, its benefits rise sharply.

**BENEFITS TO EMPLOYEES:** Every \$3 invested in Savings Bonds pay \$4 at maturity. Workers gain a 33% return on their money—enabling them in the future to buy more of the things they will want—plus the peace of mind that goes with regular saving.

**BENEFITS TO EMPLOYERS:** The feeling of security that goes with participation in Payroll Savings makes workers more contented. Worrying less, they work better. Among the more than 20,000 large companies with Payroll Savings, records show that—following installation of the Plan—production increased, absenteeism and accidents decreased!

**BENEFITS TO THE NATION:** The Payroll Savings Plan is a powerful deterrent to inflationary forces. Every Savings Bond dollar built up in the Treasury withdraws a dollar

from the swollen spending stream. The Plan thus contributes to national security—which affects your security!

**WHAT CAN YOU DO?** If your company has the Payroll Savings Plan, make sure it's being adequately promoted—backed by your top executives—to bring your company its full measure of benefits. If you haven't yet installed the Plan, why pass up its benefits any longer? All the help you need is available from your State Director, Savings Bonds Division, U. S. Treasury Department. He is listed in your telephone book. Call him now!

**Do You Realize...?**

- Over \$75,000,000,000 worth of Savings Bonds have been bought since 1941.
- More than 75% of this volume—over \$50,000,000,000—is still held by the purchasers.
- During 3 months of 1948, 1,500 additional large firms installed the Payroll Savings Plan.
- Via this plan, 7,500,000 workers are each investing on the average of \$20 per month of their pay—more than \$150,000,000 per month—in Bonds.

The Treasury Department acknowledges with appreciation the publication of this message by

## COMMUNICATIONS

This is an official U. S. Treasury advertisement prepared under the auspices of the Treasury Department and the Advertising Council.







### Personals

ED RASER stated in a recent note that the Delaware Valley Radio Association held their *Fifth Annual Old Timers' Nite* and banquet at the Hotel Stacy-Trent, Trenton, N. J. Ed, a veteran member of VWOA, was chairman of the affair. . . . The annual VWOA Spring meeting will be held around the third week in May. An interesting evening is being planned with television as the key subject. Notices of the date and place will be sent out soon. . . . John Lohmann is quite busy these days promoting Mackay Radio. . . . Fred McDermott finds that those TV programs routed through the A. T. & T. lines from New York require quite a bit of *watching*. . . . E. W. Mayer, whose home port is Overseas Foreign Airways, San Juan, P. R., is on a round-the-clock job during the installation of a variety of new equipment. EWM is maintenance technician in charge. When not working he keeps ham station KP4KD busy. . . . T. M. Moss is with the Eastern Airways in Atlanta and can still pound out his 40 *wpm*. Guess his amateur station W4HYW helps to keep him in practice. . . . R. P. Huestis, who is in charge of a big oil company's radio department in Philadelphia, reports he is steeped in work. . . . C. E. Maps likes to listen in on the *ships* with the help of his RBL-3, in his Brooklyn home. . . . No word from W. R. Marsh who lives in Oak Park, Ill. . . . G. N. Mathers is sporting a new car with all the trimmings. . . . Tom Mitchell took in the IRE banquet and appeared to be having a grand time. . . . C. F. Nehlson, who works at WLS, Chicago, has not sent in any news for many moons. . . . A report from Earl Nelson states that he has established an office in Mt. Vernon to practice consulting engineering, specializing in naval and marine electrical design. . . . E. J. Oberle is now at the Institute of Radio and Television in Jacksonville, Fla. . . . If you happen to run across any interesting sea stories that are sprinkled with radio anecdotes you can be sure that Pat O'Keefe, chief radio officer of the United Fruit liner Jamaica, wrote them. Pat is quite a story teller and



Oldtimers from the National Company, who were at the recent dinner-cruise in New York City: Clark Rodiman, R. Gentry and W. Hynes.

has had many stories published. . . . R. A. O'Neill writes that since his return to inactive duty in the Naval Reserve he has been very busy in WOR's engineering department. . . . Stewart S. Perry, of Winthrop, Mass., who dates *way back*, keeps in touch with the boys via W1BB, his amateur station. . . . A note from C. W. Phillips states that he likes San Jose, Costa Rica, where he is superintendent of Cia Radiografica International de Costa Rica. . . . F. D. Pizzuti has been teaching communications engineering at Delehanty's Institute for several years. . . . Racine, Wisconsin, is now the home of G. V. Porter, but he didn't say how he liked the weather. . . . Wm. Q. Ranft, chief engineer of Baltimore's WFBR and WFBR-FM, sends his best to all the boys. . . . Arthur Rehbein keeps himself extremely well occupied as radio supervisor of shipboard radio for American Hawaiian Steamship Co. . . . It seems that quite a few VWOA members are well rooted in the broadcast business. Just received word from Wm. E. Price saying that he is with WWDC in Washington as an engineer. WEP also likes to work amateurs over his W4MLH station. . . . And Ken Richardson of Lynbrook, Long Island, has quite a business supplying special *pm* magnets of all types and descriptions. . . . Milton Schwartz has been with CAA at La Guardia airport for the last ten years. . . . G. P. Shandy, who is one of the foremost radio direction

finder experts, is now division superintendent and regional sales manager for RMCA in Cleveland. . . . S. Spector writes that he loves the sea and after twenty-five years of brass pounding, he still thinks it better than a chicken farm. . . . R. S. Henery, who lives at Port Jefferson, L. I., is transmitter technician at RCAC, Rocky Point, L. I. . . . F. J. Herrman advises that he is manager of scientific and industrial apparatus sales for the RCA International Division, N. Y. . . . R. H. Hersey, whose career began as a ham back in 1914, is with M. Steinert & Sons, Boston, where he started in 1925. . . . R. J. Higgins, of Chicago, writes that he is representing radio manufacturers and that business is good. . . . W. W. Hofmann likes his job in Kahupu Oahu, T. H., as radio operator. . . . J. D. James likes the aims and ideals of VWOA. He is resident inspector for RMCA in the Chicago area. . . . E. J. Jones is field radio engineer with Philco in Philadelphia. . . . H. D. Kaulback, who is a Commander in the USNR, is electronics officer with headquarters 1st District, Boston. . . . J. A. Kavanagh now works at 369 Lexington Ave., N. Y. . . . V. Ladeveze, who by the way has not been to a meeting in a long while, is transmitter technician at RCAC, Rocky Point. . . . E. H. I. Lee, who for many years was an FCC inspector at New York, writes that he is very busy running the FCC office in Detroit.

Figure 1  
View of  $\pi$  arrangement in studio setup with tuning amplifier resting on top of the power supply in the left hand corner of the room.

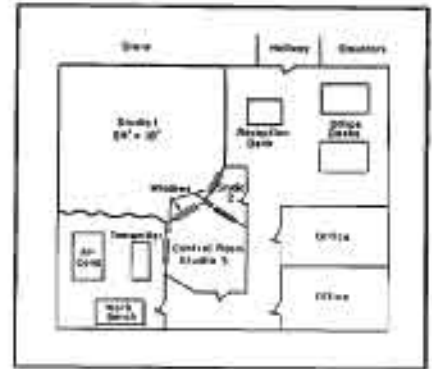

Figure 2  
Floor plan of WGNR

# FM Station Design For ONE-MAN OPERATION

WGNR, New Rochelle, Design Permits One Person To Serve as Engineer, Announcer and Platter Turner.

SMALL-STATION operation, with one person serving as a triple-threat engineer, announcer and platter turner, has become a feature of quite a few FM stations, with many ingenious procedures adopted to provide this unique type of operation.

## WGNR Setup

At one station, 1-kw WGNR,<sup>2</sup> for instance, to permit the studio-engineer to operate over an extended period of time without fatigue, important when the engineer must also speak over the air and must preserve a degree of jollity, the floor layout was planned out

by MAX ALTH

so that the engineer would have visual control of all the station's activities.

## The Layout

From a chair behind the control console at this station, it is possible to look left and see the meter panel of the transmitter, look ahead and see the main studio, or to the right and view

<sup>1</sup>Owned and operated by Julian H. Ginn, chief engineer, William Clipperty.

<sup>2</sup>Raytheon RC11.

a small studio. There's a turntable to either side and a patch field within easy reach, permitting the selection of any of six incoming lines. And incidentally the control room serves as third studio or broadcasting booth.

## Control Simplifications

To simplify control, the standard console arrangements have been modified.

Normally to switch from a record to a mike channel and back to a record with the console, many steps are involved; the  $\pi$  gain must be turned down, switch moved to monitor or neutral position, and mike channel switch moved from monitor to program. Then the mike channel gain must be turned up, the second  $\pi$  motor turned on, the record spotted and held. In the next step, the mike channel must be turned down, accompanying switch moved to monitor position, the  $\pi$  switch moved to program position,



the record released and the *tt* gain turned up.

And to play a record the *tt* motor has to be switched on, the record spotted and held, then the *tt* switch must be moved to program position, the record released and the gain turned up.

### Steps Eliminated at WGNR

At WGNR several of these steps have been eliminated. All the turntable motors start and stop automatically, via a microswitch on the *tt* pots on the control console connected in the *tt*-motor power line. When the *tt* gain is turned up, the *tt* motors start. When the gain is turned down all the way the motors stop. Thus it is only necessary to spot the record a third to a half turn back to compensate for the time lag caused by the motor picking up speed. This lag is only a fraction of a second longer than that caused by the slippage between a released record and a moving *tt*.

### Monitor Switch Change

Throwing the program-monitor switch every time a channel was switched from program to monitor was also found to be a time-consuming item, and thus was corrected by a wiring change which moved this step out of the normal or usual time sequence, and made it possible to switch well in advance of the actual need.

### Switch Operation

A switch was installed in a portion of the monitor-program switch circuit, so that in open position, the channel is killed. Thus with this switch open it's

Figure 3

Balanced *H* pad circuit (600/600 ohms). With attenuation of 5 db, the resistors at A = 82 ohms and at B 510 ohms; 6-db attenuation, A is 100 ohms and B 390 ohms; 10-db attenuation, A is 150 ohms and B is 220 ohms; 12 db attenuation, A is 180 ohms and B is 160 ohms; 15-db attenuation, A is 200 ohms and B is 110 ohms; 20-db attenuation, A is 240 ohms and B is 62 ohms and 30-db attenuation, A is 270 ohms and B is 18 ohms. All resistors are of one-watt rating.

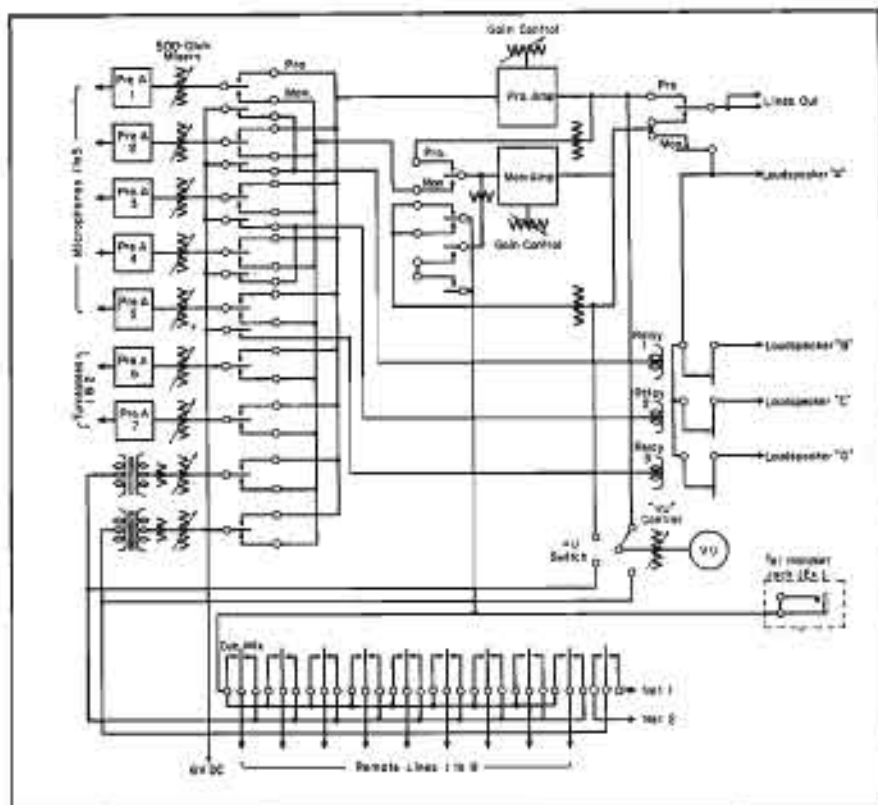
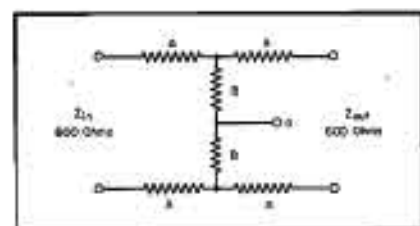

Figure 4  
Block diagram of the console used at WGNR.

possible to throw the program-monitor switch into program position, and nothing will go out over the air.

### Dual Use of Gain Control

The switch is connected to each channel pot or gain control so that the switch is open when the gain is turned down; closed when the gain is turned up. The switching of the channel is therefore a function of the gain control.

These changes cut the normal six-step operation down to three, one of which can be performed at any time.

### Cueing Contact

In another innovation, a cueing amplifier and speaker have been hooked into the console system by using a contact on a pot not used in console operation: When the pot is turned all the way down and the channel is closed, the center contact on the pot is connected to this isolated contact, thus providing the cueing contact.

### Amplifier Feed

The amplifier, a seven-watt unit, feeds into a speaker mounted in the control room. When the pot of a particular channel is turned all the way

down, the mike or phonograph connected to that channel feeds the cueing amplifier, and is heard in the control room.

### Talk Back Circuit

A talk-back circuit permits two-way contact and facilitates studio-to-control room operation.

Figure 5  
Circuit changes made in console to facilitate program monitoring.

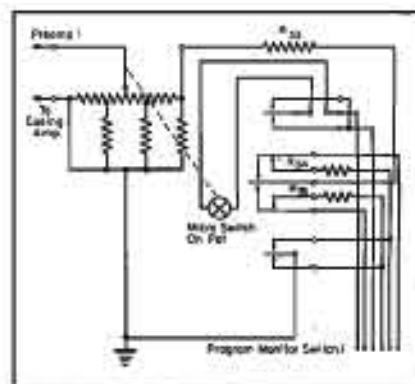



(Continued from page 9)

turer said that 100% modulation provides an output of up to 26 dbm. The equipment is normally adjusted for an average output of +4 vw; 100% modulation provides +20 dbm. The noise level of the system is 60 db below 100% modulation; the noise level being that signal which exists at the output terminals of the playback amplifier when recording in the normal manner with the record input terminals terminated in a resistance equal to the rated source impedance (this includes record and playback amplifier noise level or any noise caused by bias, crasing or stray pickup in the heads).

One manufacturer displayed a rack-mounted tape recorder which was designed for not only recording and reproducing for permanent record work, but for delayed broadcast application. The proposed NAB standards served as a basis for the design of this equipment, providing a 30 to 15,000-cps range with less than a 1% rms wow and flutter at a 15" tape speed.

Passive reflectors for TV relaying were also widely discussed at the meeting. One manufacturer reported that he has designed a tower and reflector package which includes 12' x 12' screens for reflector work and towers fabricated in 5', 10' and 20' sections. These towers can be raised to a maximum height of 350'.

The passive reflector approach is being used effectively by DuMont in their New Haven system and by Crosley in their Cincinnati link.

Other highlight features at the show included simplified FM and TV tower structures, high power disc rectification systems, extremely compact and highly efficient studio consoles, streamlined tower lighting systems, etc.—L. W.

## Tube Engineering

(Continued from page 13)

approximately 10 db in the range from dc to 200 mc as compared to conventional cathode-ray tubes.

### Acknowledgement

The author is grateful to F. W. Kammerer of the New Jersey Bell Telephone Labs, who was in large measure responsible for initiating design work on the 5XP, and to S. J. Koch and A. Y. Bentley of the Allen B. Du Mont Labs, whose assistance and cooperation made construction of the tubes possible.

# WIRE-WOUND CONTROLS

- ★ Winding skill second to none
- ★ Large and small controls
- ★ Velvety-smooth rotation, always
- ★ Minimized wear-and-tear
- ★ Taps and tapers. Tandem units

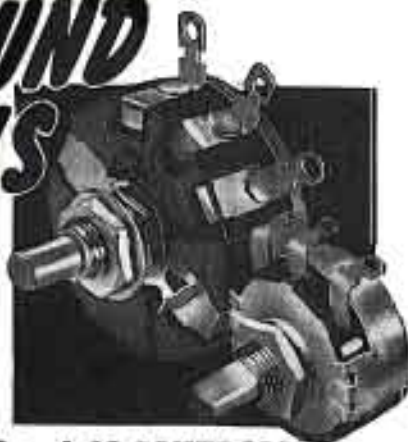

## CLAROSTAT SERIES 58 and 43 CONTROLS

The large-sized Series 58 Clarostat rheostat or potentiometer offers laboratory-grade performance at mass-production cost. 1-21/32" dia. 1 to 100,000 ohms. 3 watts, linear. The finest standard wire-wound control made!

The midsize Series 43 control is a real space-saver. Only 1 1/8" dia. 1 to 10,000 ohms. 2 watts, average. Hundreds of thousands of Clarostat wire-wound controls are in daily use. Their performance, dependability and long life, are a matter of record.

Ask for Bulletins 116 and 118. Let us quote on your needs.



CLAROSTAT



Controls and Resistors

CLAROSTAT MFG. CO., INC. • DOVER, NEW HAMPSHIRE • In Canada: CANADIAN MARCONI CO., LTD. Montreal, P. Q., and branches

## MEASUREMENTS CORPORATION MODEL 80 STANDARD SIGNAL GENERATOR



### 2 to 400 MEGACYCLES

**MODULATION:** Amplitude modulation is continuously variable from 0 to 30%, indicated by a meter on the panel. An internal 400 or 1000 cycle audio oscillator is provided. Modulation may also be applied from an external source. Pulse modulation may be applied to the oscillator from an external source through a special connector. Pulses of 1 microsecond can be obtained at higher carrier frequencies.

**FREQUENCY ACCURACY** ±.5%

**OUTPUT VOLTAGE** 0.1 to 100,000 microvolts

**OUTPUT IMPEDANCE** 50 ohms

MANUFACTURERS OF  
Standard Signal Generators  
Pulse Generators  
FM Signal Generators  
Square Wave Generators  
Vacuum Tube Voltmeters  
VHF Radio Noise & Field Strength Meters  
Capacity Bridges  
Megohm Meters  
Phase Sequence Indicators  
Television and FM Test Equipment

MEASUREMENTS CORPORATION

BOONTON NEW JERSEY



## 2-Wire Method

(Continued from page 24)

requires careful investigation. Assuming a successful system could be engineered, applications would include privately-owned aircraft, boats, police cars, and other vehicles fitted with communication equipment. Potential uses would be limited only by the extra cost of the balanced system over the conventional unshielded system.

A version of this system that is of interest for the most critical applications is shown in Figure 7. This version includes a shield around the balanced two-wire line and is neither cheap nor simple. However, it may offer worthwhile advantages over the conventional shielded systems used in commercial and military aircraft. More tolerance could be shown in the maintenance of the ignition harness to obtain a prescribed noise suppression. At first glance the doubling of the number of leads would appear to greatly increase the bulk of the harness. Actually, a smaller total cross-section of wires would be needed, since halving the voltage on each lead reduces the insulation thickness in like manner.

### Immediate Application

Providing a magneto, with a balanced primary winding as indicated in Figure 7, is a minor modification that is relatively simple to make. Special plugs and distributors would not be required for this application of the balanced two-wire principle. Such an arrangement would be of advantage in that interference resulting from a bad joint in the primary shielding would be minimized.

The primary wiring from the magnetos to the pilot's ignition switches ranges up to 100' or more in length in multi-engined aircraft and frequently comes in close proximity to radio equipment. Thus, in spite of the relatively low voltage existing in this circuit, interference can occur and is often encountered.

## Field Intensity Tests

(Continued from page 16)

is little point in making the studies, for it then becomes worthless to the station. If the measurements are not going to be made and analyzed by qualified personnel using proper equipment, no measurements should be made.

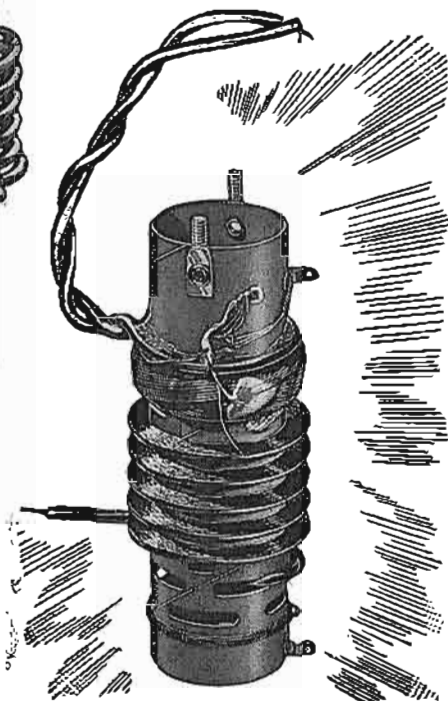

☆  
2 new stars in the field

☆  
For  
TELEVISION  
RECEIVERS

☆ ☆

## Specify COSMALITE\*

Cosmalite Coil Forms give exceptional performance at a definite saving in cost to you.

Punched, threaded, notched and grooved to meet your individual specifications.

•  
Ask us about the many various punching dies we have available.

•  
Inquiries given quick action and specialized attention.

\* Reg. U. S. Pat. Off.

The **CLEVELAND CONTAINER Co.**  
6201 BARBERTON AVE. CLEVELAND 2, OHIO

PLANTS AND SALES OFFICES at Plymouth, Wisc., Chicago, Detroit, Ogdensburg, N.Y., Jamesburg, N.J.  
ABRASIVE DIVISION at Cleveland, Ohio  
CANADIAN PLANT: The Cleveland Container, Canada, Ltd., Prescott, Ontario

### REPRESENTATIVES

CANADA  
METROPOLITAN  
NEW YORK  
NEW ENGLAND

WM. T. BARRON, EIGHTH LINE, RR #1, OAKVILLE, ONTARIO  
R. T. MURRAY, 614 CENTRAL AVE., EAST ORANGE, N.J.  
E. P. PACK AND ASSOCIATES, 968 FARMINGTON AVE.  
WEST HARTFORD, CONN.



# The Industry Offers



## TELEVISION EQUIPMENT CORP. CAMERAS

Television camera chains, models 1200A and 1200 B, designed expressly for the Image Orthicon pickup tube, have been developed by the Television Equipment Corporation, 238 William St., New York 7, N. Y.

A three lens turret is provided for operational flexibility, and up to 1000' of cable can be used between cameras and control equipments. Although basically a single camera system employing only three fundamental units, it may be expanded to a four camera chain. Intercommunication between units is provided. The cameras can use all types of the new super-sensitive 3" Image Orthicon tubes interchangeably, and are accordingly useful for both remote and studio broadcasting pickups.

## REL 10-WATT FM TRANSMITTER

A ten-watt FM educational transmitter, model 700, designed for schools, universities and all other non-commercial educational institutions where coverage of a campus area is all that is required, has been announced by Radio Engineering Laboratories, 35-54 36th Street, Long Island City, New York.

Employs the Ferrazoid modulator, which is the standard unit employed in REL commercial broadcast transmitters.

Transmitter employs eighteen standard tubes and is housed in an aluminum cabinet, 29" high, 29" wide and 14 1/2" deep.

Equipment features maximum distortion of less than a 1% from 50 to 15,000 cycles at 100% modulation and an FM signal-to-noise ratio of 75 db below 100% modulation.

## G.E. COMMUNICATION TYPE MINIATURE TUBES

Miniature tubes for mobile communication and aircraft radio equipment have been announced by the tube divisions of G. E.

The tube, GL-5670, is a high frequency twin triode.

Tube has gold-plated grids and a modified heater design to withstand a great number of on-off cycles.

Heater voltage is 6.3 ac or dc, while the heater current is 0.320 amperes. Plate voltage is 300 volts, maximum. Has a glass envelope and glass button, 9-pin base. Maximum seated height is 1 3/4", while the maximum diameter is 3/8".

## BUCHANAN INSULATED METALLIC BUSHINGS

Insulated metallic conduit bushings which are said to provide protection against abrasion of cable insulation and accidental grounds, have been announced by the Buchanan Electrical Products Corp., 1290 Central Ave., Hillside, N. J. Known as *Bushkuds*, they require no inside lockouts. Metal bases are fabricated from corrosion resistant, wrought alloy of high mechanical strength. Threads are free, clean-cut and non-seizing. Insulation has high dielectric strength and resistance to moisture absorption and is permanently and securely positioned in the metallic base.

All sizes are approved by Underwriters' Laboratories.

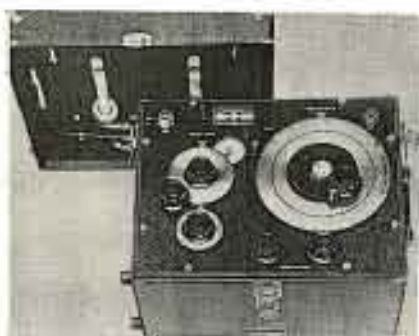

## G-R SUPERSONIC AND LOW RF IMPEDANCE BRIDGE

A bridge, type 916-AL, which covers a nominal frequency range of 30 kc to 5 mc, and can, however, be used at frequencies as low as 15 kc, has been announced by the General Radio Co., 275 Massachusetts Ave., Cambridge 39, Mass.

The bridge reads directly in reactance at all frequencies, and directly in resistance at 100 kc. For other frequencies reactance readings are divided by the frequency in hundreds of kilocycles. Resistance range is 0-1000 ohms. Reactance range at 100 kc is 11,000 ohms.

The bridge will measure resistors, capacitors, inductors, lines, antennas and other networks.

## STANCOR TV REPLACEMENTS

Two horizontal output transformers have been added to the Stancor line of TV replacement components made by Standard Transformer Corp., 3580 Elston Ave., Chicago 18, Ill. Units, the A-8117 and A-8118, are designed for replacement of units used in leading brands of TV receivers.

A four-page illustrated catalog, bulletin DD337R, with detailed specifications and prices of all Stancor TV components, is available.

## LEACH RELAY

A hermetically sealed relay, the 637-37A, provided with a standard octal plug having a metal locating pin and glass-to-metal seal on the plug pins, has been announced by Leach Relay and Electric Co., 59-15 Avalon Blvd., Los Angeles, Calif.

Relay is equipped with a 235-ohm continuous duty coil and is double pole, double throw having 1/16" contacts rated at 10 amperes resistive load. Said to be capable of withstanding 10g vibration, 16g acceleration, 25g shock and protection from salt spray, sand, dust, high altitudes and high and low temperature operations.

## RADIO RECEPTOR DRY RECTIFIERS

Miniature selenium type dry rectifiers for bias supply have been announced by the Radio Receptor Co., Inc., 24 North 9th St., Brooklyn 11, New York. Number 1X1, cartridge type, is rated at 100 v ac input and 10 ma dc output; number 1M1, the plate type, is rated at 25v ac input and 100 ma dc output. For bias use the current drain is usually negligible but the rectifiers may be applied to other half-wave applications within the limits specified.

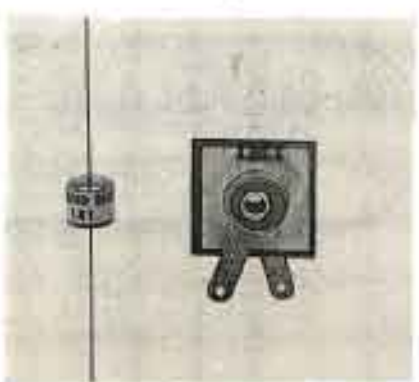

## WESTON LOW LEVEL SPEECH ANALYZER

An analyzer, model 779, type 5, which measures low level speech circuits with a minimum of disturbance of these circuits, has been announced by the Weston Electrical Instrument Corp., 417 Fellinghaysen Ave., Newark 3, N. J.

Analyzer makes dbm readings at all audio and carrier current frequencies. The ac response is said to be essentially flat to 50 kc within 1 db over the range -20 to +22 dbm, and is usable for comparative db readings on all common carrier current frequencies above 50 kc.

Uses a rectified circuit with broad frequency and temperature compensation, which is said to permit measurement of transmission line characteristics over long distances in the presence of wide ambient temperature variations.

The 1-volt ac range has an impedance of 2500 ohms, which is said to permit its use as a bridging device with a minimum effect on relays and other line equipment components. In addition, a 600-ohm switching circuit converts the analyzer to a terminating db meter on the -20 to +2 dbm range.

Ranges to 1,000 volts ac and dc, from 100 microamperes to 10 amperes, and resistance ranges from 1,000 ohms to 10 megohms.

## RCA CONSOLETTA

A studio control consolette, incorporating two on meters, which is said to permit increased flexibility in auditioning and pretesting program signal levels without interruption of on-the-air programs, has been announced by the RCA Engineering Products Department.

The consolette (type 75-D) features connection of the meters to rotary selector switches to provide program monitoring and plate current checks of all tubes in program channels. Each meter has a companion attenuator, which allows the 100% mark on each meter scale to be calibrated for 4, 8, 12, and 16 mv.

## PHILCO FM CENTRAL STATION UNIT

A central station unit for use in FM radio-telephone communications systems in the 30 to 44 and 152 to 162 mc bands has been announced by the Philco Corp., Philadelphia 34, Pa. Equipment chassis are mounted on a standard size telephone relay rack which is hinged at the bottom to permit tilting the equipment forward for easy access to the rear of the chassis.

The front door is provided with a lock. A loudspeaker and indicator lamps are built in at the front of the cabinet. Either a dynamic or carbon microphone may be used.

For operation in the 30 to 44 mc band, there is a choice of a 30 or 50-watt transmitter. On the 152 to 162 mc band, the rated transmitter output is 40 watts. Transmitters employ automatic deviation control to confine the bandwidth of transmissions within legal and neighborly limits.



### RCA SECTIONAL CONSTRUCTION STATION CONTROL CONSOLE

A universal transmitter control console, BTC-1A, featuring *block type* construction, has been announced by RCA. Up to nine different types of *blocks* or sections may be selected and bolted together in various combinations to form a console.

The basic unit consists of an audio control turret and an *rf* control turret mounted on two desk-type sections with removable end pieces. Other available units are a 90° desk section, a TV control console, complete turret with blank panel, and a 45° wing turret with blank panel. The console may be built in a straight line, or in *L* or *U* formations.

The audio turret of the basic BTC-1A FM console contains all mixing and switching facilities for up to six inputs, a seven-position selector switch for monitoring all important circuits, and individual bridging pads for equalizing the level of the various signal sources.

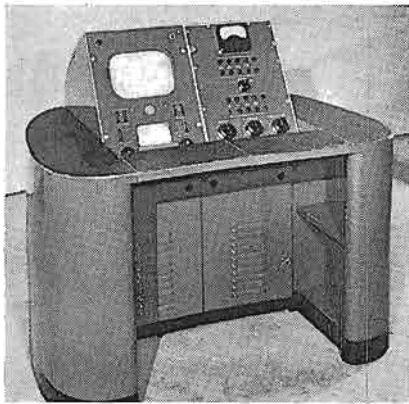

### SIMPSON TV ANTENNA COMPASS

A TV antenna compass, model 351, which takes the physical form of a pocket size meter connected by an insulation-piercing alligator clip to the video input of the cathode-ray tube in the television receiver, has been announced by the Simpson Electric Company, 5200-18 W. Kinzie St., Chicago, Ill. By an extension cord, the unit is carried to the antenna site. With a test pattern tuned in on the area's weakest station, the antenna is then rotated for maximum deflection of the TV antenna compass. Instrument is said to permit also peaking of the *rf* and oscillator systems right on the station itself.

\*\*\*

### CANNON CONNECTORS

Redesign of the vibrationproof series of AN type connectors and the addition of such features as radio shielding, pressurizing and moisture-proofing, has been announced by the Cannon Electric Development Co., 3209 Humboldt St., Los Angeles 31, Calif.

The series, for the time being, will carry the prefix of the AN shell (such as 08 or 06) with the letters *AP* for a complete number.

Shell material is aluminum alloy with Dural coupling nuts. Low millivolt drop contacts are copper alloy, silver plated. Standard AN-type layouts are used but are not interchangeable with other AN fittings.

For further information, the hi-G-1 bulletin is available.

\*\*\*

### Correction

THE ARTICLE *General Folded Dipole Antenna Design* which appeared in the April issue of COMMUNICATIONS was a co-author project and prepared by D. L. Waidelich and E. J. Vredenburg, Jr., professor and assistant professor, respectively, of the Department of Electrical Engineering, University of Missouri.

### PROJECTION TV

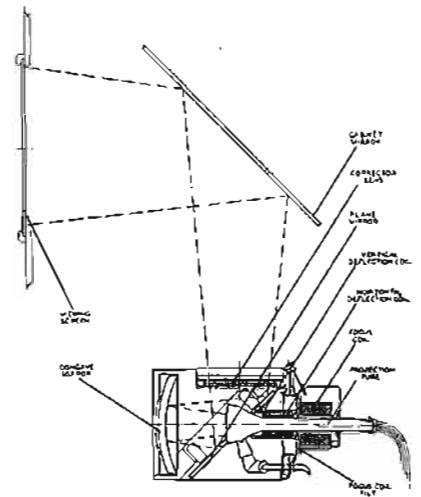

How the recently announced North American Philips *Protegram* system operates: Image on face of 2½" *crt* (in optical box at bottom of drawing) is reflected from concave mirror (left) to the plane mirror which is inclined at a 45° angle. The image then passes through the corrector lens and is folded by the cabinet mirror which projects the image on a viewing screen at upper left. Optical system is a modified Schmidt.

## TV Distribution System

IN THE article on *TV Distribution System for Laboratory Use* by Joseph Fisher of Philco, which appeared in the February issue of COMMUNICATIONS, Figures 5 and 7 showed cathode-ray tube photographs of pictures produced by a flying spot video signal generator after passing through 1,000'

of RG6/U uncompensated and compensated coaxial line. Due to excessive white saturation in the multiple photographic processes necessary to produce a halftone plate, Figure 7 failed to give a true indication of the quality of signal actually produced

when using 1,000' of compensated video line. The two *crt* views below, in which photographic white saturation has been avoided, present a much more accurate representation of the two conditions as actually seen on the video monitor.

Figure 5

Picture transmitted over 1000' of unqualized coaxial line.

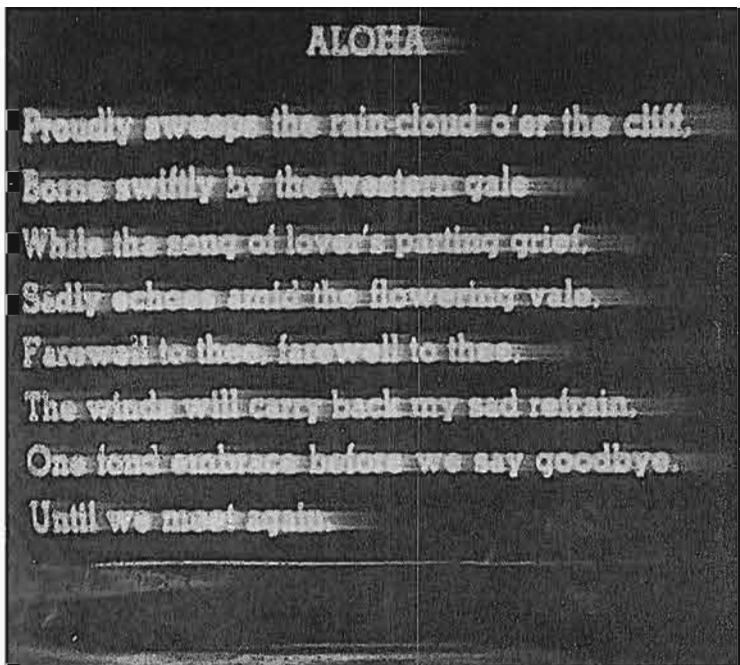
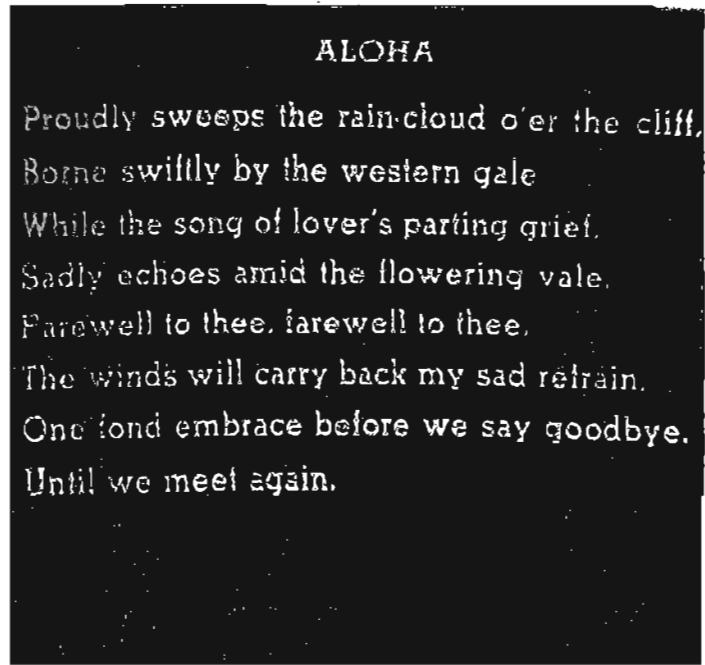

Figure 7

Picture transmitted over 1000' of equalized coaxial line.



**NEW  
IMPROVED  
SENSATIONAL**  
**AN INDOOR ANTENNA  
WITH AMAZING  
RECEPTION QUALITIES**

**Super  
Wasp**

ONLY  
**\$6.95**  
No. 6468



Vastly improves reception when used to supplement existing outdoor antennas.

- Made by Insuline — pioneer in television since 1927.
- Telescopic dipoles open up to 78"; closes to 32".
- Table-top model.
- Maximum signal strength.
- Jiffy installation.
- Beautifully designed golden-tone brass dipoles and Bakelite walnut base.
- Non-skid, can't-scratch cushions.
- Instantaneous tuning and orienting.
- Complete 300 ohm connecting lead and mounting lugs.
- No visible screws, bolts or nuts.

**LANDLORD'S PERMISSION UNNECESSARY**

Stock, feature, and display the new Super Wasp Antenna, a natural for fast, easy and profitable sales.

**WRITE FOR COMPLETE CATALOG**

**insuline**    
CORPORATION OF AMERICA  
INSULINE BUILDING, 26-07 35th AVENUE,  
LONG ISLAND CITY, N. Y.  
West Coast Branch and Warehouse:  
1335 South Flower St., Los Angeles, Calif.  
Exclusive Canadian Sales Agents:  
CANADIAN MARCONI COMPANY  
Montreal, Canada

## News Briefs

### PERSONALS

**Hugh Wahwright** is now sales engineer for the electronics division of Sylvania Electric Products, Inc.

**Walter T. Hannigan** has been named sales rep in the New England territory for the Red Bank Division of the Bendix Aviation Corp., Red Bank, N. J.

Hannigan will headquarter at 43 Leon Street, Boston.



W. T. Hannigan.

**Paul L. Palmerton** has been named acting director of public relations of Western Electric Co., succeeding Fred B. Wright who will retire under the company's age retirement rule.

**John M. Van Beuren** has been reelected as chairman of the board of Measurements Corp., Boston, N. J. Harry W. Houck was renamed president, Jerry B. Mintz, vice president; Robert Meyer, secretary-treasurer and Nelson C. DeLond, Sr., assistant secretary.

**James L. Fouch**, formerly with the Universal Microphone Co., has become sales manager for the Cinema Engineering Co., Burbank, Calif.



J. L. Fouch

**R. T. Penoyer** has been appointed manager of the G. E. Buffalo tube works, succeeding R. O. Poag who died recently. Penoyer will be concerned mainly with the manufacture of television picture tubes, chief product of the Buffalo plant.

**F. R. Kendall** has become Motorola regional manager for Maine, Massachusetts, New Hampshire, Vermont and New York State, excepting the metropolitan New York City area. Five assistant engineers are to be under his supervision.

**Lowell E. White** has been appointed Motorola manager of the region consisting of Rhode Island, Connecticut, New Jersey and the metropolitan New York City area, and will direct four assistant engineers.

**S. J. Horner** has been appointed sales supervisor for Carbonyl iron powder, made by Antara Products, a division of General Aniline & Film Corp.

**Herbert Bayard Swaps** had joined RCA in the capacity of adviser and consultant.

Swaps recently resigned as director of CBS of which he was a director and member of the Executive Committee, since 1952.

Swaps was formerly a reporter on *The World*, of which he later became the executive editor.

**Ellis L. Redden** has been appointed director of advertising and sales promotion for Motorola, Inc., Chicago.

Redden was formerly with the Crosley Division of the Avco Manufacturing Corp.

FOR PUBLIC  
ADDRESS, RADIO,  
and kindred fields,  
**JONES** 400  
SERIES  
**PLUGS & SOCKETS**

of proven quality!



P-406-CCT



S-406-AB

Socket contacts phosphor bronze cadmium plated. Plug contacts hard brass cadmium plated. Insulation molded bakelite. Plugs and sockets polarized. 2, 4, 6, 8, 10, 12 contacts. Steel caps with baked black crackle enamel.

Catalog No. 17 gives full information on complete line of Jones Electrical Connecting Devices — Plugs, Sockets and Terminal Strips. Write

**HOWARD B. JONES DIVISION**  
Cinch Mfg. Corp.  
7240 W. GEORGE ST. CHICAGO 18, ILL.

**BIRTCHER**

STAINLESS STEEL - LOCKING TYPE

**TUBE  
CLAMPS**

Stainless  
Steel

Corrosion  
Proof



**83 VARIATIONS**

Where vibration is a problem, Birtcher Locking TUBE CLAMPS offer a foolproof, practical solution. Recommended for all types of tubes and similar plug-in components.

**More than three million of these clamps in use.**

**FREE CATALOG**

Send for samples of Birtcher stainless steel tube clamps and our standard catalog listing tube base types, recommended clamp designs, and price list.

**THE BIRTCHER CORPORATION**  
5057 HUNTINGTON DR. LOS ANGELES 32



James J. Sutherland has been appointed general manager of the electronics division of Sylvania Electric Products, Inc.



J. J. Sutherland

Edward W. Butler has been appointed director of the radio division of PTR, Clifton, N. J. Butler was formerly general manager of the electronics division of Sylvania Electric Products, Inc.



R. S. Perry (above)  
E. W. Butler

Raymond S. Perry, formerly president of the Elicor Corp., Chicago, has been appointed general sales manager of PTR.

#### LITERATURE

Cleveland Electronics, Inc., 6611 Euclid Ave., Cleveland 3, Ohio, has issued a catalog of its Cletron replacement loudspeaker line. Catalog lists speakers for use in the home and in auto, FM and television sets, and for sound work in labs and in public address systems.

Victors Electric Division, Victors, Inc., 1815 Locust St., St. Louis 3, Mo., have published a 24-page selenium rectifier catalog (VC-3000) and 12-page photoelectric cell catalog (VC-4000).

Selenium rectifier catalog covers rectifier characteristics, applications, design factors, etc. Photoelectric cell catalog also covers cell applications and design specifications.

International Resistance Co., 401 N. Broad St., Phila. 5, Pa., have issued a 4-page technical data bulletin, H-1, describing insulated oil chokes specially designed for television and FM receiver requirements.

The Andrew Corp., 361 East 75th Street, Chicago 19, Ill., has released two bulletins covering their cardioid antenna (bulletin 100) and corner reflector antenna (bulletin 84).

Helitz and Kaufman, Ltd., 50 Drumm St., San Francisco 11, Calif., have prepared a 25-page catalog describing frequency-shift exciters, dual diversity receiver terminals, line amplifiers, tone to dc keyers, mobile transmitter-receivers, bridging amplifiers, crystal units, etc.

Lantern Electric Co., Inc., 1124 County Road, San Carlos, Calif., has released a 4-page folder, form 4P4, describing type 44 carrier equipment and how it can be employed for voice, telegraph, telemetering and control installations.

A tabulation is included which details the type of operation; transmission speed or band width; number of channels; channel spacing; spectrum location; and equipment type designations related to the functions of voice; teletype or multiplex printer; on-off control; dialing, pulsing, or manual-automatic keying; or remote tuning with reversible motors.

Electro-Voice, Inc., Buchanan, Michigan, have prepared a 2-page bulletin, No. 145, on the E-V model 1000 speech clipper.

Bulletin explains how the speech clipper clips the tops and bottoms from speech frequencies which rise above a pre-set amplitude and how it increases the ratio of consonant-to-vowel intensity so that transmitted voice becomes clearer and more intelligible.

52 VANDERBILT AVENUE  
NEW YORK 17, N. Y.

# Group Subscription Plan



Saves Fifty Per Cent of the Yearly Subscription Price if Four or More Subscriptions (Including Your Own) Are Properly Entered on This Form.

1 Year — \$1.00  
2 Years — \$2.00  
(Foreign: Add \$1.00 for postage)

Please enter annual subscriptions (12 issues) for each of the undersigned for which payment is enclosed at the rate of \$1.00 each. (This rate applies only on 4 or more subscriptions when occupations are given.)

Name .....

Address .....

City-State .....

Occupation .....

Employed by .....

Nature of Business .....

(State if Manufacturer, Broadcast Station, etc.)

Your Title .....

Your Department .....

Name .....

Address .....

City-State .....

Occupation .....

Employed by .....

Nature of Business .....

(State if Manufacturer, Broadcast Station, etc.)

Your Title .....

Your Department .....

Name .....

Address .....

City-State .....

Occupation .....

Employed by .....

Nature of Business .....

(State if Manufacturer, Broadcast Station, etc.)

Your Title .....

Your Department .....

Name .....

Address .....

City-State .....

Occupation .....

Employed by .....

Nature of Business .....

(State if Manufacturer, Broadcast Station, etc.)

Your Title .....

Your Department .....

Business or professional classifications are required to complete our records. Each subscriber should write one of the following classifications in space indicated. Use separate sheet of paper for additional names.

CHIEF ENGINEER      ENGINEER      EXECUTIVE  
PURCHASING AGENT      DEPARTMENT MANAGER

State your classification if not listed.

This Group Sent In By—

Name .....

Address .....

Designed for



Application



**The No. 90651  
GRID DIP METER**

The No. 90651 MILLEN GRID DIP METER is compact and completely self contained. The AC power supply is of the "transformer" type. The drum dial has seven calibrated uniform length scales from 1.5 MC to 270 MC with generous over laps plus an arbitrary scale for use with special application inductors. Internal terminal strip permits battery operation for antenna measurement.

**JAMES MILLEN  
MFG. CO., INC.**

MAIN OFFICE AND FACTORY  
**MALDEN  
MASSACHUSETTS**



**Last Minute Reports . .**

AIRBORNE COMMUNICATIONS will be highlighted in a series of papers to be presented at the first conference of the Dayton Chapter of the IRE which will be held on June 3rd and 4th at the Biltmore Hotel. Topics scheduled to be covered include aircraft communications equipment, air navigation and traffic control systems, antenna developments and high speed aircraft design trends, etc. Dr. W. L. Everitt, Dean of Electrical Engineering at the University of Illinois will be toastmaster at the banquet scheduled for June 3rd. . . . Dr. V. K. Zworykin, vice president and technical consultant of RCA Laboratories, Division of RCA, will receive the 1948 Lamme medal during the annual AIEE summer meeting, which will be held in Swampscott, Mass. during the latter part of June. . . . Special types of television equipment, which include microwave reflectors and mounts, all-metal tripods and dollies and one-man control lighting systems, now being manufactured by Television Associates, Inc., of which Capt. Bill Eddy is president, will be distributed by RCA. Commenting on a recently proposed television equipment standardizing program, J. R. Poppele, TBA proxy and chief engineer of WOR, declared recently that he will bring this fact to the attention of the engineering committee of TBA so that steps can be taken to standardize joints, circuits and accessories and thus make interchangeability of manufacturer's products possible. . . . The instrument division of Allen B. DuMont Laboratories have published a new edition of their booklet entitled *The Cathode Ray Tube and Typical Applications*. . . . Allen B. DuMont, proxy of Allen B. DuMont Labs announced recently that the price of the 12 1/4" 12QP4 picture tube has been reduced to \$57.50 and the 12" 12JP4 reduced to \$54.75. . . . Dr. Harvey C. Rentschler, former director of Westinghouse lamp and tube research, died recently. . . . Clarence Towse is now head of the engineering department of KGVO, Missoula, Montana. He was formerly with KIOD of Spencer, Iowa. . . . Don Dahl is now chief op at KGVO. . . . Arthur P. Goetze has been named works manager of the Western Electric plants in Tonawanda, Allentown and New York City. . . . Henry Grossman, formerly director of broadcast operations at CBS has become director of building and construction. Grossman will continue to supervise TV and technical building operations and plant construction. . . . W. W. Watts, vice president in charge of RCA engineering products department, was host to a group of officers and faculty members from the current class of the Industrial College for the Armed Forces in Camden, N. J., recently. . . . The seventy-five passenger *Clipper America* is now equipped with a Kellogg intercommunications system for use by the ship's three-man crew and two stewardesses. . . . Motorola, Inc. have opened a new research lab in Phoenix, Arizona, which will concern itself exclusively to electronic research in military fields. The lab will be under the direction of Daniel E. Noble, director of research and vice president in charge of communications, of the communications and electronics division, Motorola. Dr. Angus A. Trevida has been named chief engineer and general manager of the lab.

**ADVERTISERS IN THIS ISSUE**

**COMMUNICATIONS INDEX**

MAY, 1949

BENDIX AVIATION CORP.....	Back Cover
Agency: MacGann, John & Adams, Inc.	
BELL TELEPHONE LABORATORIES.....	39
Agency: N. W. Ayer & Son, Inc.	
THE BIRCHER CORPORATION.....	34
Agency: W. C. Jeffrey Co.	
J. H. BUNNELL & CO.....	Inside Front Cover
Agency: E. B. Ruzicka, Advertising	
CLAROSTAT MFG. CO., INC.....	30
Agency: Austin C. Leachours & Staff	
THE CLEVELAND CONTAINER CO.....	31
Agency: The Nestlé Service Co.	
ALLEN B. DUMONT LABORATORIES, INC.....	1
Agency: Austin C. Leachours & Staff	
GENERAL RADIO CO.....	Inside Back Cover
Agency: The Banta Press	
HEWLETT-PACKARD CO.....	17
Agency: L. C. Cole, Advertising	
INSULINE CORPORATION OF AMERICA.....	34
Agency: H. H. Leon Co.	
HOWARD S. JONES DIV. CINCH MFG. CORP...:	34
Agency: Syracuse, MacKenzie & Co.	
KELLOGG SWITCHBOARD & SUPPLY CO.....	5
Agency: Swiss Associates, Inc.	
HACHLETT LABORATORIES, INC.....	4, 5
Agency: E. East Boston, Advertising	
MEASUREMENTS CORPORATION.....	30
Agency: Frederick Smith	
JAMES MILLEN MFG. CO., INC.....	28
RADIO CORPORATION OF AMERICA.....	12, 13
Agency: J. Walter Thompson Co.	
SYLVANIA ELECTRIC PRODUCTS, INC.....	1
Agency: Neest-Essent Co.	
U. S. TREASURY DEPT.....	25



# For CONTINUOUS Recording of Small Voltages and Currents

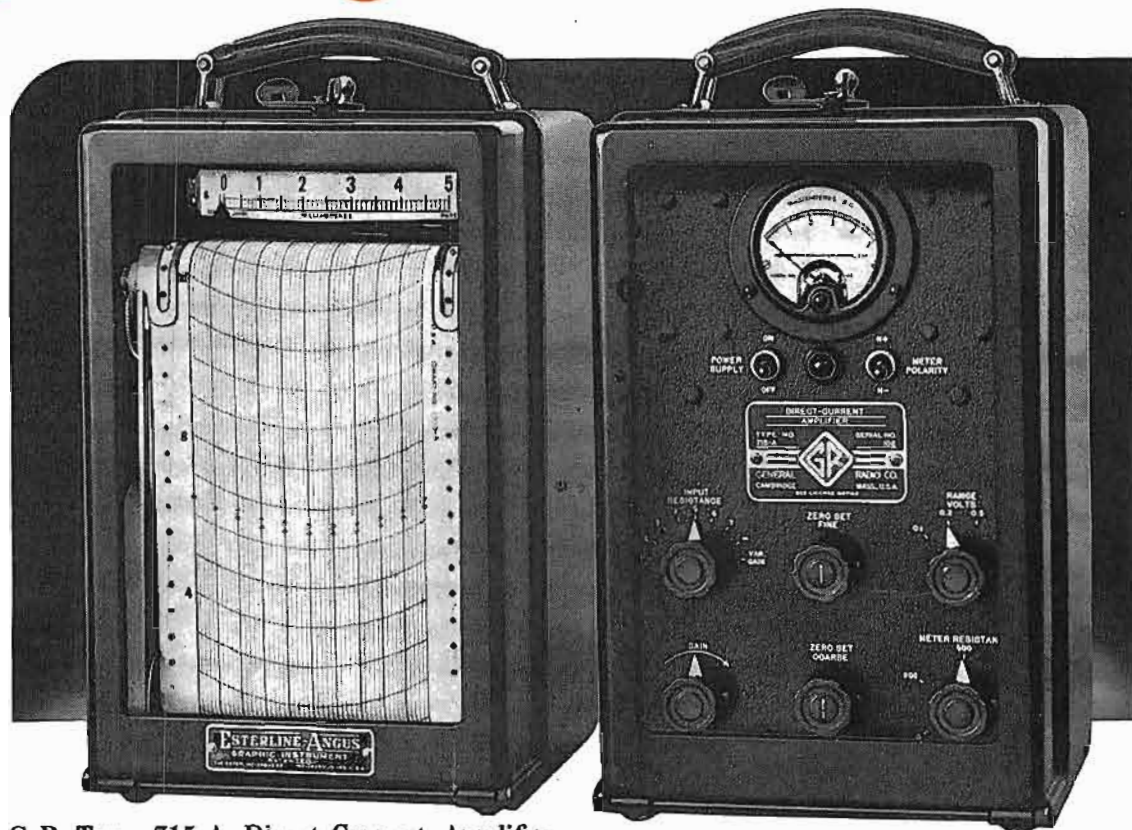

• The G-R Type 715-A Direct-Current Amplifier was designed particularly for operation with the Esterline-Angus 5-milliamper recorder to be used as a calibrated recording voltmeter. With appropriate selection of built-in input resistances the combination also is a recording milliammeter or microammeter.

The amplifier can be used in automatic process control circuits where its output operates relays to control the device which feeds the input of the amplifier. It may be operated from frequency meters, sound and vibration measuring equipment, photoelectric cells, resistance strain gauges, resistance thermometers and other similar devices.

The Type 715-A D-C Amplifier has high gain, operates from an a-c line, is very simple to use, requires practically no attention, can be used for very long periods for continuous recording, is exceptionally free from effects of line voltage variation, and has a wide range of built-in input voltage and resistance combinations.

Full-scale output has been made 5 milliamperes to operate the 5 m-a recorder. This full-scale output can be obtained on calibrated ranges from input voltages of 0.1, 0.2, 0.5 and 1.0 volt. The input resistance can be varied between 100 ohms and 10 megohms in powers of 10 by means of a panel switch.

The amplifier is supplied either in a cast metal case to match the Esterline-Angus recorder, or in a walnut cabinet.

## SPECIFICATIONS

**RANGE:** Four switch selected calibrated ranges supplying 5 m-a linear output in recorder circuit for input voltages of 0.1, 0.2, 0.5, and 1.0 volt.

**ACCURACY:** Approximately 1% as a calibrated voltmeter.

**INPUT:** From 100 ohms to 10 megohms, in powers of 10, to adjust input resistance and permit use of instrument as calibrated millivoltmeter or microammeter. Short- and open-circuit positions on selector switch. For over one volt input variable gain control provided to adjust voltage to desired value. Input resistance is then about 150,000 ohms.

**GRID CURRENT:** In input circuit is less than 0.002 microampere.

**OUTPUT CIRCUIT:** Designed to operate 5 m-a meter on panel, or Esterline-Angus 5 m-a recorder. Provided with compensating resistance to match external device to normal resistance of 1,000 ohms.

TYPE 715-AE D-C AMPLIFIER  
(Metal Case) ..... \$345.00  
TYPE 715-AM D-C AMPLIFIER  
(Walnut Cabinet) ..... \$300.00



**GENERAL RADIO COMPANY** Cambridge 39, Massachusetts

90 West St., New York 6 920 S. Michigan Ave., Chicago 5 1000 N. Seward St., Los Angeles 38





JET PLANE



ROCKET OFF RAMP



AMPHIBIOUS TANK

# EXPLOSION-PROOF, REGULATED DYNAMOTOR



RADAR



## CHECK AND BE SURE

- Voltage regulation
- Frequency regulation
- Speed control
- High temperature operation
- High altitude operation
- Waterproof construction
- Noise proof (conducted and radiated)

Only Bendix can give you all of these important features.

Bendix realizes that today's standards are tomorrow's discards. Our research program is designed to keep *ahead* of tomorrow's needs—to produce equipment that is *ready, when* it is needed. Typical of the results achieved by this far-sighted development work are explosion-proof dynamotors, regulated dynamotors, inverters and D.C. motors\* manufactured by Bendix. In addition, Bendix research has produced rotating equipment that will withstand extreme conditions of altitude, temperature, humidity, immersion, shock, and acceleration. To those members of the electronic industry engaged in the design and development of guided missiles, telemetering apparatus, radio, radar, or other electronic devices, we suggest that you call on:

\*Bendix motors meet specification ANM-40.

For immediate information call our Engineering Staff—Red Bank 6-3600. • Staff Members:  
 W. H. Wells, Director, Sales Engineering  
 K. H. Fox, Chief Engineer  
 J. J. Korzdorfer, Project Engineer.

RED BANK DIVISION of  
 Red Bank, New Jersey



• • • • •

Dynamotors • Inverters • Convertors • D. C. Motors • Carbon Pile Voltage Regulators