

\$1.00

COMMUNICATIONS

a merger of
RADIO ENGINEERING
...
COMMUNICATION &
BROADCAST ENGINEERING
...
THE BROADCAST ENGINEER

JANUARY
1938

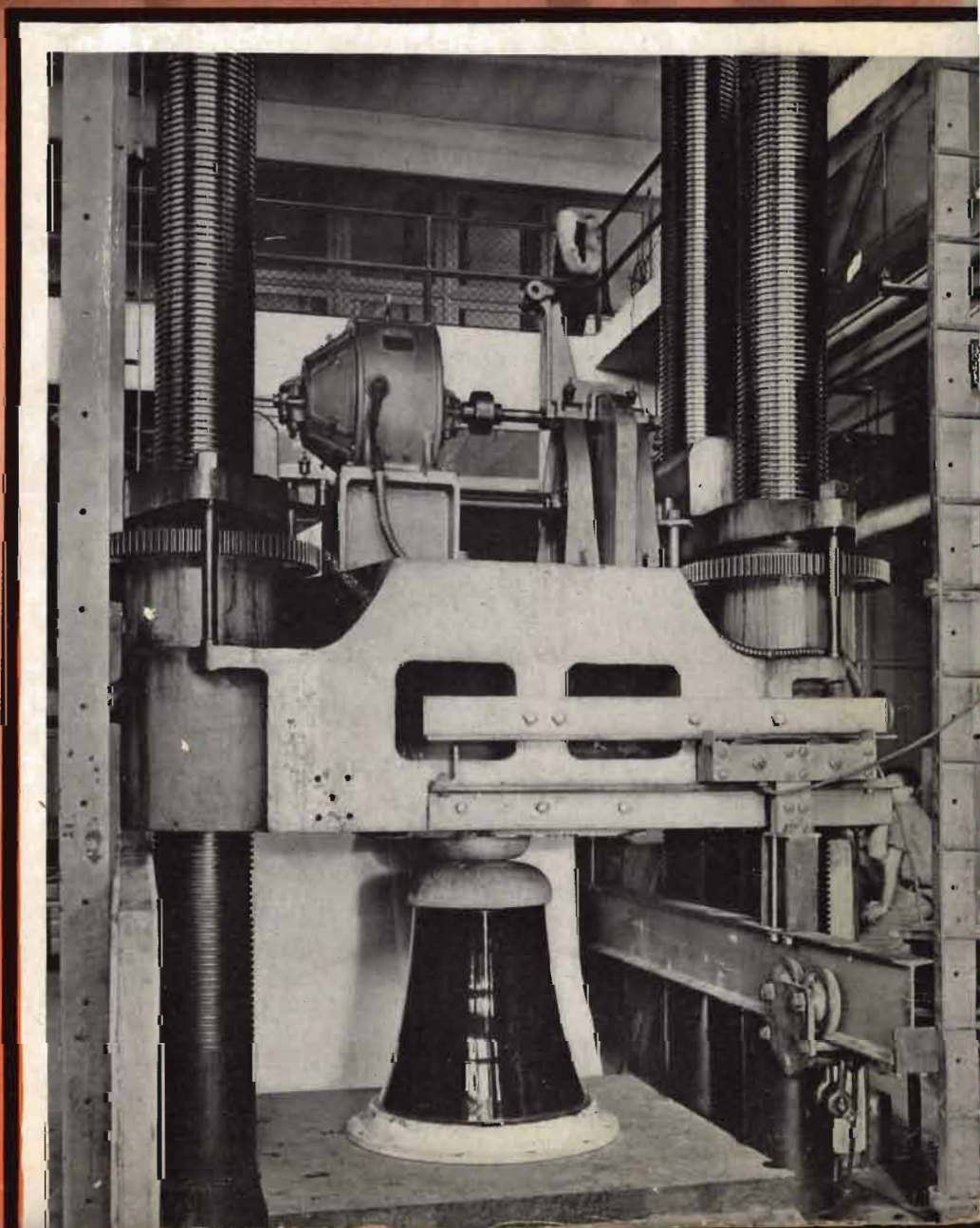

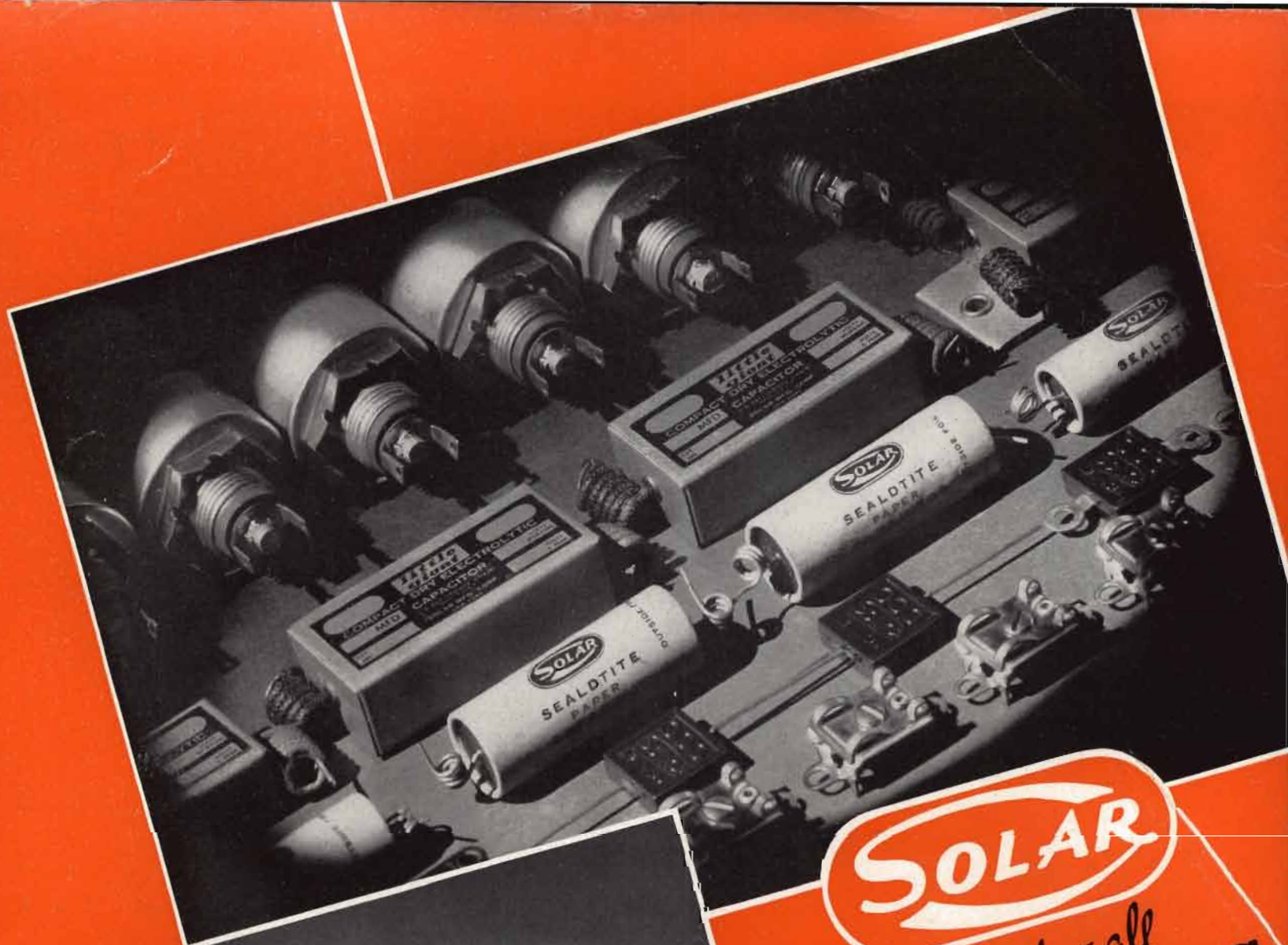

SOLAR

Quality above all
CAPACITORS

This is a symbol of staunch performance, of reliability far more important than momentary price advantage. EXPERIENCE the hidden factor that makes QUALITY recommends: "Standardize on SOLAR"

NINETY PERCENT of all radio set manufacturers in this country are on our active ledger. We enjoy the benefit of constant contact with their technical personnel... a real advantage.

WET DRY MICA
 PAPER TRIMMER
 TRANSMITTING

SOLAR MFG. CORP., 599-601 BROADWAY, NEW YORK, N. Y.

ALSMAG

STEATITE INSULATION ©

*Tailored to each
Customers Specification*

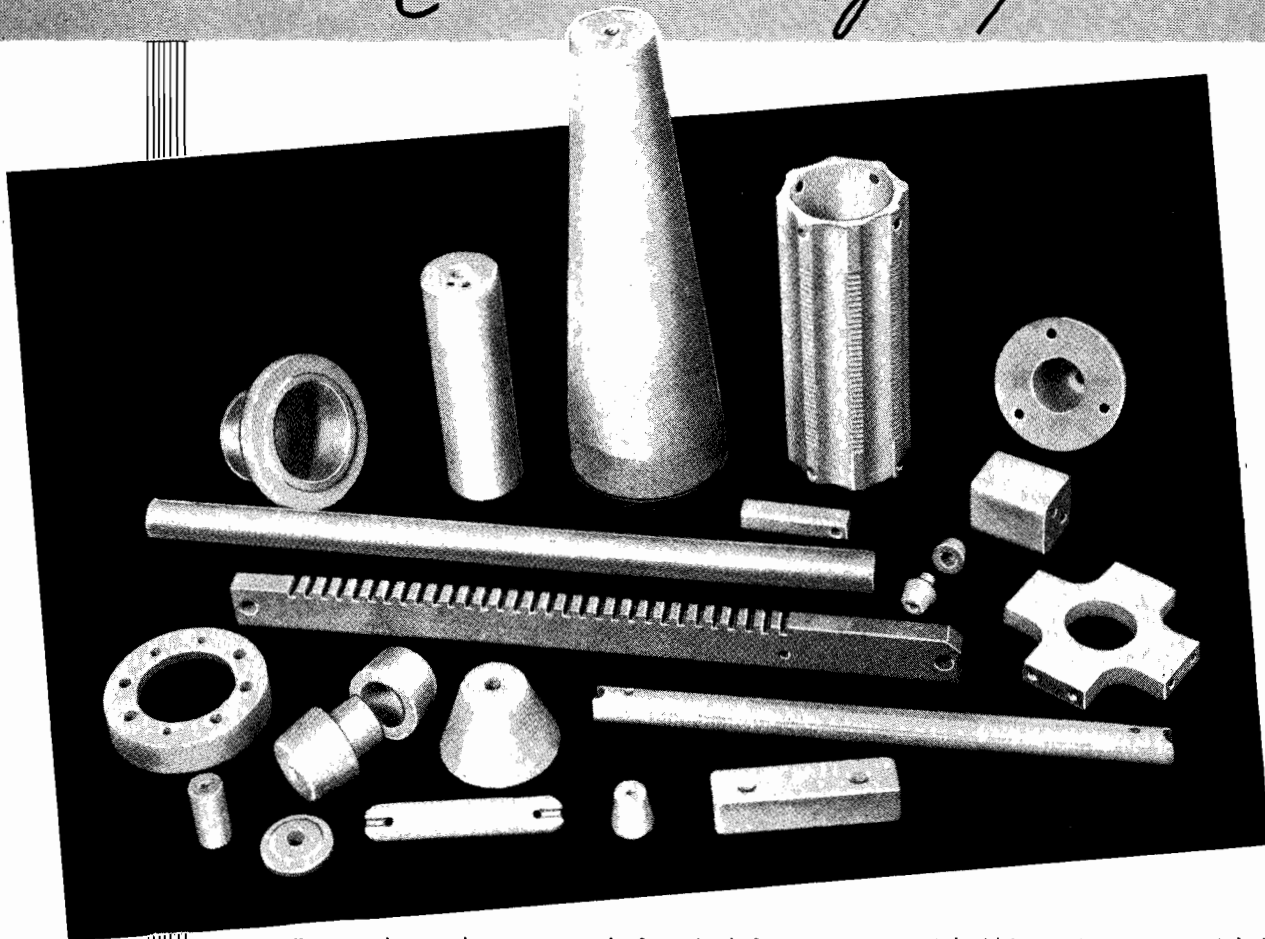

All parts shown above are made from high-frequency material, Alsmag 196, a material that complies with Navy Specifications for Class "G" insulation.

You can definitely reduce losses and increase performance by the use of this true steatite ceramic.

Our Engineering Department will be glad to help you devise a design that will permit the use of this material at minimum cost.

Write for Property Chart on our ceramic materials.

Sales Offices (See phone book)

NEW YORK
BOSTON

WASHINGTON

PHILADELPHIA

CLEVELAND

CHICAGO

ST. LOUIS

LOS ANGELES
SAN FRANCISCO

AMERICAN LAVA CORPORATION Chattanooga, Tenn.

COMMUNICATIONS

Member of Audit Bureau of Circulations

RAY D. RETTENMEYER • Editors • W. W. WALTZ

CONTENTS FOR JANUARY

Cover Illustration: Compression testing a 1600-pound porcelain insulator at the Bureau of Standards in Washington, D. C. Manufactured by Locke insulator Corporation as the base support for the new 625-foot antenna tower of General Electric's station WGY, the insulator was designed for a maximum permanent load of 500,000 pounds with a safety factor of four.

	Page
With the Editors	4
Remote Pickup Equipment	7
By John P. Taylor	
Design of Resistance-Coupled Amplifiers	11
By Edward J. Rhoad	
Principles of the Musa	14
By C. B. Feldman	
Amplification Problems of Television	15
By F. Alton Everest	
Notes and Comment	20
Program of Broadcast Engineering Conference	22
Production Development of Television Tubes	24
Telecommunication	28
Over the Tape	30
Veteran Wireless Operators Association News	40
The Market Place	43
Index of Advertisers	48

VOLUME 18

NUMBER 1

BRYAN S. DAVIS
President

JAMES A. WALKER
Secretary

Chicago Office—608 S. Dearborn St.
Telephone: Wabash 1903.

Published Monthly by the
BRYAN DAVIS PUBLISHING CO., INC.

19 East 47th Street
New York City
New York Telephone: PLaza 3-0483



SANFORD R. COWAN
Manager

PAUL S. WEIL
Advertising Manager

A. B. CARLSEN
Circulation Manager

Wellington, New Zealand—Te Aro Book Depot.
Melbourne, Australia—McGill's Agency.

Entered as second class matter October 1, 1937, at the Post Office at New York, N. Y., under the act of March 3, 1879. Yearly subscription rate: \$2.00 in the United States and Canada, \$3.00 in foreign countries. Single copies: twenty-five cents in United States and Canada, thirty-five cents in foreign countries.

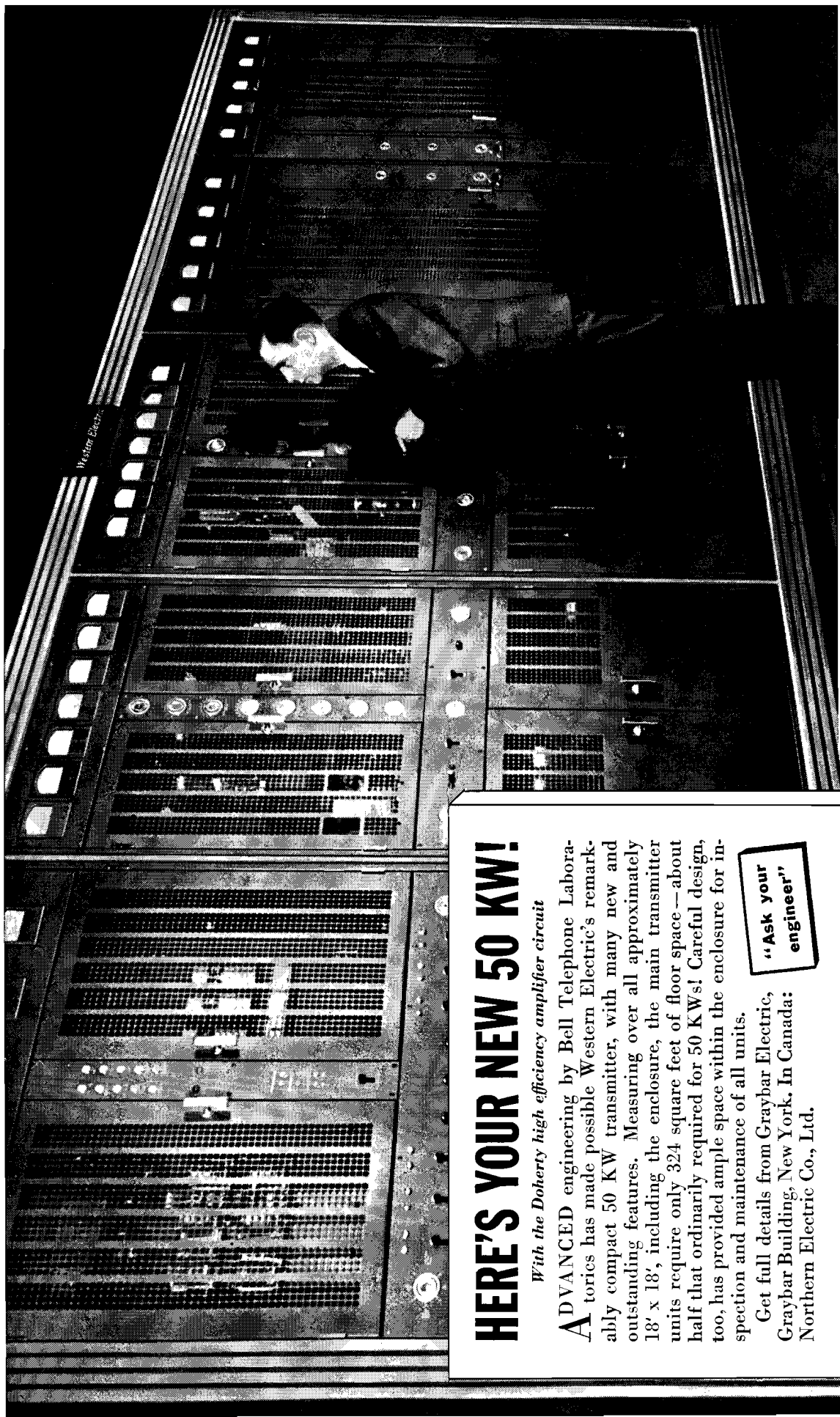

Western Electric

HERE'S YOUR NEW 50 KW!

With the Doherty high efficiency amplifier circuit

ADVANCED engineering by Bell Telephone Laboratories has made possible Western Electric's remarkably compact 50 KW transmitter, with many new and outstanding features. Measuring over all approximately 18' x 18', including the enclosure, the main transmitter units require only 324 square feet of floor space—about half that ordinarily required for 50 KWs! Careful design, too, has provided ample space within the enclosure for inspection and maintenance of all units.

Get full details from Graybar Electric, Graybar Building, New York. In Canada: Northern Electric Co., Ltd.

"Ask your engineer"

Western Electric

BROADCASTING EQUIPMENT

WITH THE EDITORS

CONVENTIONS

WITH THE ADVENT of 1938, conventions seem to be in order. Since these gatherings will cover nearly every phase of radio, we list them briefly here.

During the month of January, the Institute of the Aeronautical Sciences will hold its Sixth Annual Meeting at the Pupin Physics Laboratories, Columbia University, New York City, on January 24, 25, 26 and 27. (Further information regarding this gathering will be found elsewhere in this issue.) Almost simultaneously, the American Institute of Electrical Engineers will present its convention at the Engineering Building, 33 West 39 Street, New York City, the dates being January 24, 25, 26, 27 and 28.

From February 7 to 18, the Department of Electrical Engineering of the Ohio State University is sponsoring a conference on broadcast engineering at Columbus, Ohio. The complete program of this meeting will be found on the following pages.

The Sixteenth Annual Convention of the National Association of Broadcasters will be held at the Hotel Willard, Washington, D. C., from February 14 to 16 inclusive. A complete program of this convention will be published in the February issue of COMMUNICATIONS.

As announced in the December issue, the Institution of Radio Engineers are organizing a World Radio Convention to be held at Sydney, Australia, from April 4 to 14. This gathering will cover subjects of interest to all radio engineers, including wave propagation, telecommunication, broadcast transmission, broadcast receivers, television, sound projection, etc.

Also during April, the Society of Motion Picture Engineers will hold their Spring Convention at the Wardman Park Hotel, Washington, D. C., from April 25 to 28.

Complete details of this gathering are not available, but it is anticipated that further information will be announced at an early date.

FCC ANNUAL REPORT

ACCORDING TO NAB REPORTS, no recommendations were made by the Federal Communications Commission in its annual report to Congress. However, it is expected that some recommendations for legislation will be made before this session of Congress adjourns.

The Commission reports that as of June 30, 1937, there were 704 broadcast stations operating in the United States. During the fiscal year the Commission authorized fifty-one new stations and deleted seven.

PRESENTING

IN THIS ISSUE appears a paper prepared by F. Alton Everest, entitled "Amplification Problems of Television." Since this article presents a summary of important, yet not widely appreciated, factors governing television amplifier response, we feel that it will be of interest to a great many engineers engaged in television design.

JOHN P. TAYLOR's article on "Remote Pickup Equipments" should be of particular interest to broadcast engineers, since it covers most of the commercial equipments announced to date. As Mr. Taylor points out, there seems to be an equipment to suit almost any need.

ALSO in this issue will be found a description of the "musa" (multiple-unit steerable antenna for short-wave reception), data on the design of resistance-coupled amplifiers, and material on the production development of television tubes.

During the last fifty years science and invention have led us farther and farther from the world that was; deeper and deeper into a new environment. . . . We may confidently depend on science to provide the foundation for a better social structure, if we can prevail upon ourselves to build thereon in a different frame of mind. . . . ARTHUR D. LITTLE

1,202,240 STITCHES PER STOCKING

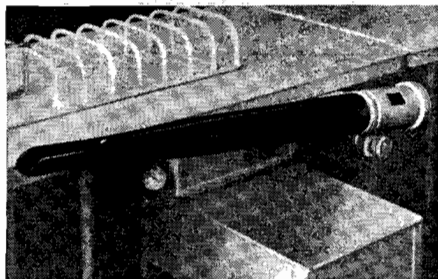

SYNTHANE makes it possible for the manufacturer to scan the 1,202,240 stitches of a sheer silk stocking in the twinkling of an eye. . . . *Synthane* Bakelite-laminated is used in stocking examiners

SHEETS • RODS • TUBES • FABRICATED PARTS • SILENT STABILIZED GEAR MATERIAL

because it has three desirable properties in *combination*—smoothness, solid color, and wear resistance. . . . You can get this same combination of properties or almost any other combination you desire in *Synthane*, for *Synthane* has an unusually broad *combination* of physical, electrical, chemical and mechanical properties. *Synthane* is a dense, solid material, tough, strong and light in weight—an excellent electric insulator—with a low power fac-

tor, low moisture absorption, high dielectric strength and low dielectric constant. It's chemically inert and corrosion resistant. It machines easily. *Synthane* is often the most *economical* material to use through lowered production costs, better product performance, dependable adherence to standards. Why not write for data on *Synthane*, giving us your requirements?

SYNTHANE CORPORATION, OAKS, PENNSYLVANIA

SYNTHANE
Bakelite —  laminated

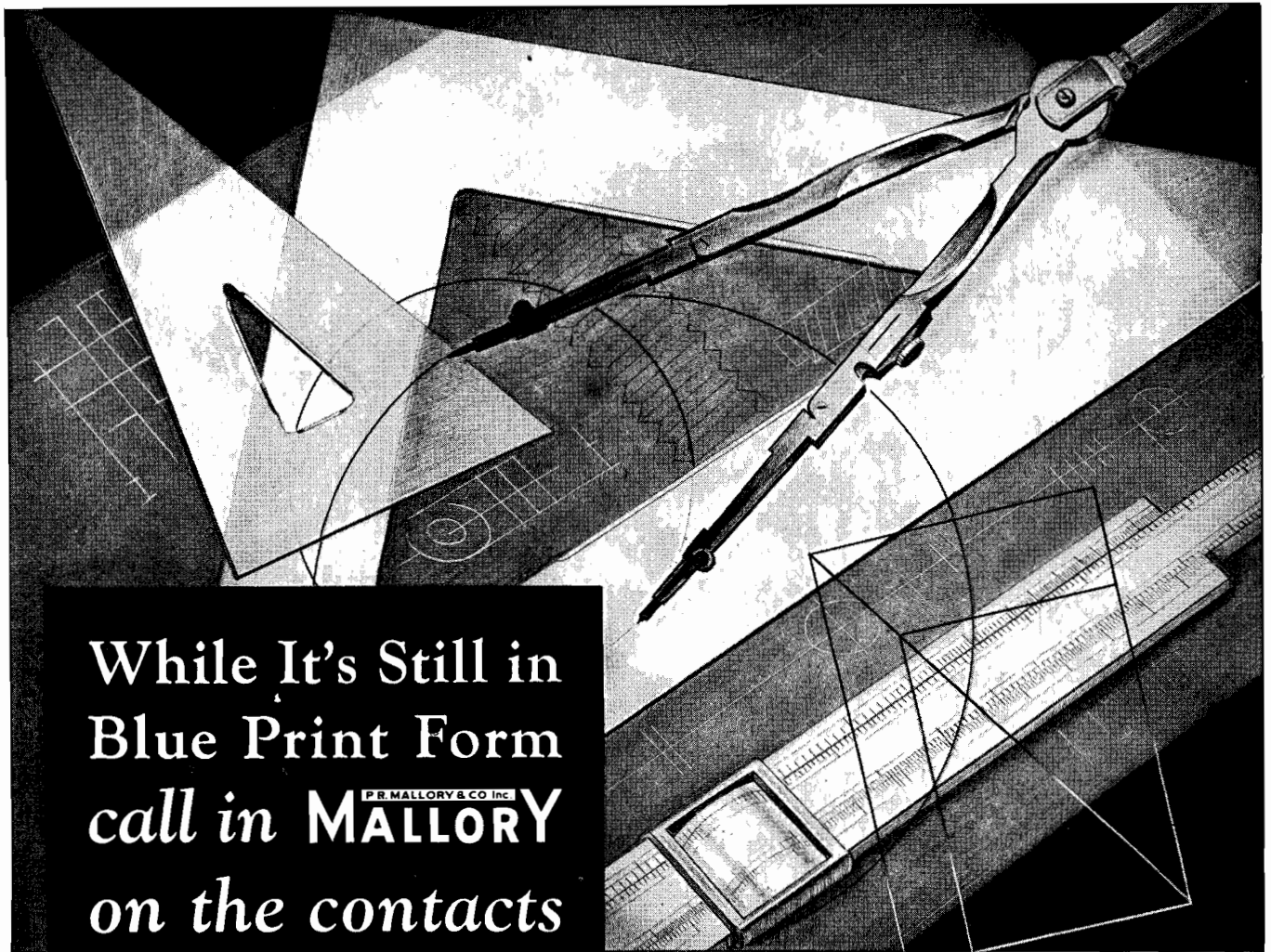

While It's Still in
Blue Print Form
P. R. MALLORY & CO. Inc.
call in **MALLORY**
on the contacts

Successful production, performance and salability of electrical products begin at the drawing board.

That is the place where "materials" are selected.

It is the place where, for electrical contacts, not only materials, but design should be considered.

Costly changes are frequently fore-stalled when Mallory is consulted as to contacts while products are still in the blue-print stage. Worth-while savings are often made by slight design changes that permit the incorporation

of *standard* rather than *special* contacts. Mallory has devoted many years to the designing and manufacturing of contacts for every class of electrical service. Mallory covers the field in the perfection and production of everything from giant circuit breaker contacts to the tiny "pin-points" of metal used in automobile ignition circuits.

Have you an electrical product in the blue-print stage? Mallory will appreciate your contact inquiries. And —you'll appreciate the help that Mallory offers.

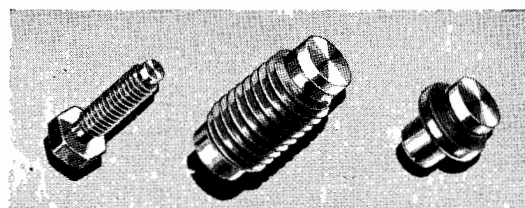

P. R. MALLORY & CO. Inc.
MALLORY

P. R. MALLORY & CO., Inc.
INDIANAPOLIS, INDIANA
Cable Address — PELMALLO

ELECTRICAL CONTACTS

COMMUNICATIONS

FOR JANUARY, 1938

REMOTE PICKUP EQUIPMENT

THERE ARE no limits—practically—to what may be called “a remote pickup.” It may mean a regular field day for the “special events” staff—with pack transmitters, mobile transmitters, and dozens of microphones; it may mean an opera pickup, with a “master-mind” to direct the delicate (supposedly) mixing operations; or it may mean a broadcast—from a newspaper office, for instance—with one microphone and no control operator at all. The correspondingly varied requirements, together with the almost irresistible—to some engineers—desire to “roll-their-own” have in the

By **JOHN P. TAYLOR**

past made for rather widespread use of “station-built” remote equipments. Recently, however, there has been a quite noticeable change in this situation. For one thing, there are now all sorts and sizes of equipment available—at least one, it would seem, for every imaginable application. Again, a little figuring indicates that, at present price levels, equipments of comparable quality are very nearly if not actually more expensive to build than to buy. As a result, most stations are now buying their remote equipments and the manufacturers are making it more and more easy for them to do so.

explicit requirements of remote use. For one thing, the necessity of extreme portability places quite definite limits on size and weight. The equally primary requirement of feeding into a land line fixes the necessary output level in the neighborhood of 0 db to + 6 db. And, of course, the desirability of providing for use of high-quality microphones establishes the necessary gain at something like 85 db minimum.

Where the application requirements are not fixed, however, there is almost no agreement. The number of mixer input positions, for instance, varies from

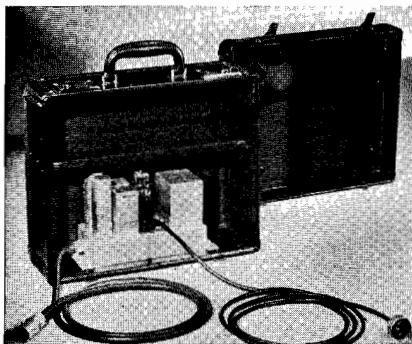

Fig. 2. Power-supply unit of the 22A. The extra space in this and amplifier case are for mikes and cables.

VARIETY

The prospective purchaser, for instance, will find that not only are there several categories of equipment, but that, in fact, there is little standardization even among equipments of the same general classification—so that the possibilities are almost equal to the number of different models. Of course, there are likenesses, dictated, in most part, by the

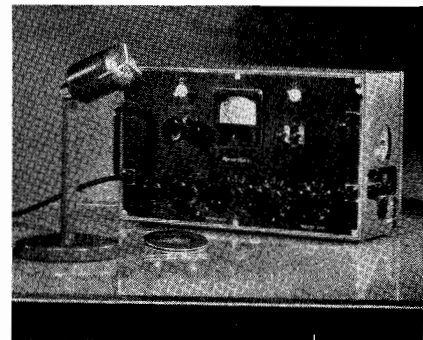
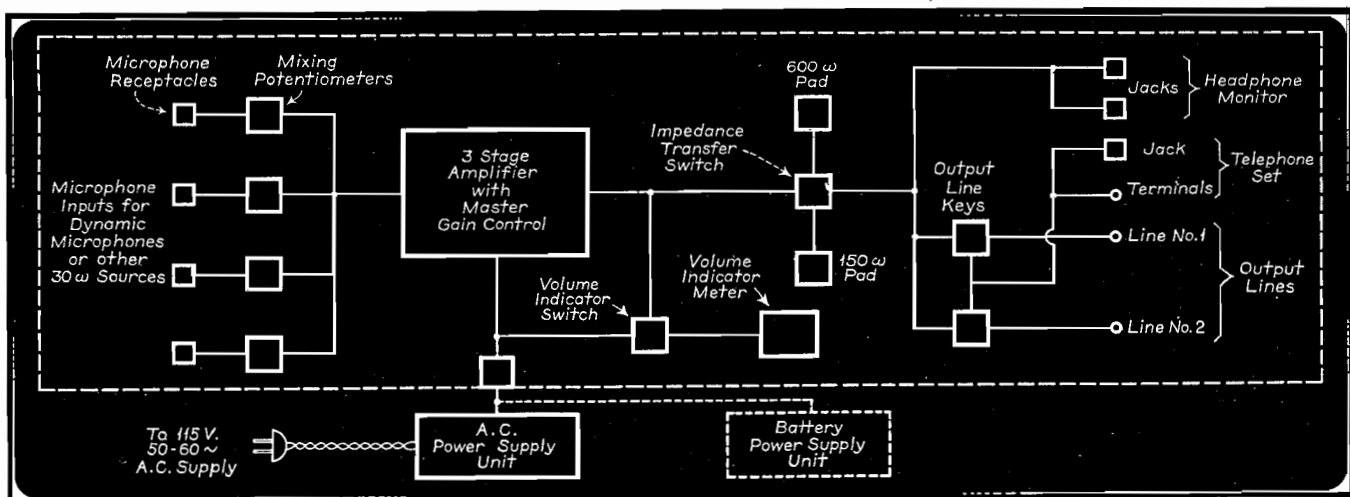

Fig. 1. Type 22A equipment (Western Electric) as set up for use. Amplifier has been removed from carrying case.

Fig. 3. Block diagram of 22A equipment.



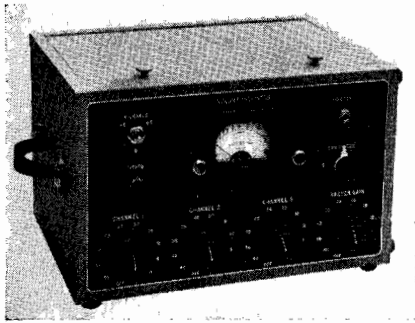

Fig. 5-A. The amplifier of the 12X equipment (Collins).

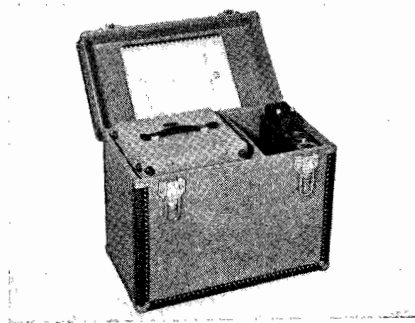

Fig. 5-B. The complete assembly of the 12X equipment.

one to four—and even the latter limit is presumably established only by practical considerations. Tubes are about evenly divided between metal and glass. Because of the high gain required, pentodes are generally used in the first stage, but the type varies—77's, 6J7G's, 6J7's, 1603's and 1609's each seeing some use. Output tubes may be 6A6's, 6F6's, 1609's or 6C5's push-pull. "Low-noise" tubes are used in one make. These are of advantage in reducing microphonics—disadvantages are the higher price and the fact that they cannot always be procured locally. Most exasperating lack of standardization is in input impedances. The trouble traces, of course, to microphone impedances—each manufacturer designing his equipment to match his microphones. In the equipments having transformer input—i.e., mixers following preamplifier stages—the problem has been met by providing tapped or double windings, but in those where the microphones feed directly into the mixer there is no ready solution, as any change requires changing the attenuators.

THREE CLASSIFICATIONS

Despite the various differences between models it is, nevertheless, possible to divide the available equipments into three fairly well defined classifications—thereby avoiding repetition in description, as well as giving some assistance in obtaining a perspective. These three categories are: (1) large-size equipments, (2) medium-size or "jewel-box" equipments, and (3) small-size equipments. This division is entirely

Fig. 11-A. Exterior of the 12Y unit (Collins).

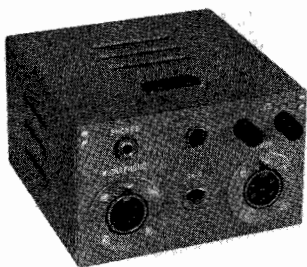

arbitrary, and leaves plenty of room for difference of opinion. Certainly open to criticism, is the use of size—even nominally—as a criterion. However, if not taken too literally, it will be found to coincide to a considerable degree with the facilities provided—by the three classes of equipment—and, perhaps somewhat less accurately, with the price range of these. Thus it serves as a starting point, leaving discrepancies to be noted as they appear.

LARGE-SIZE EQUIPMENTS

The larger-size equipments are, of course, also the most complete. The differences—between these and smaller equipments—while not striking, are quite definite. There are more mixers—either three or four—and more auxiliary controls. The volume indicator is provided with a range-selector switch and the meter with some means of illumination. Provision of dual output lines, switch-controlled, is another distinguishing feature. Constructions, due to the greater available space, are less cramped, thereby making for easier servicing. The designs, in general, are based on the requirements of network technique. In fact, at least two of these equipments were developed directly to network specifications—and the whole group might well be referred to as "network-type" equipments.

Type 22A (Western Electric): The 22A amplifier is a good example of this type of equipment—and a brief description of this unit will, therefore, serve to indicate the general features of the group. The equipment—amplifier, power

Fig. 11-B. Interior of 12Y equipment for semi-fixed use.

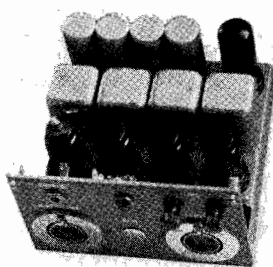

supply, cables and microphones, everything in fact, except stands—is contained in two convenient-size (14 x 16¾ x 7¾ inches) carrying cases. These weigh only 15 lbs. and 21½ lbs. respectively—so that they may be easily carried by one man. The amplifier unit itself (Fig. 1) is only 9 inches high, 15 inches long, and 5 inches deep—the additional space in the carrying case being a small compartment for microphones, etc. Similarly, the power-supply unit (Fig. 2) occupies only part of the second case. For battery operation, this unit is removed and small-size batteries placed in the same space.

The arrangement of the facilities of the 22A unit is indicated in the block diagram (Fig. 3). Four microphone inputs feed directly into the four-position mixing system. The combined output is amplified by a three-stage amplifier which uses 6J7's in the first two stages and a 6F6 in the output stage.

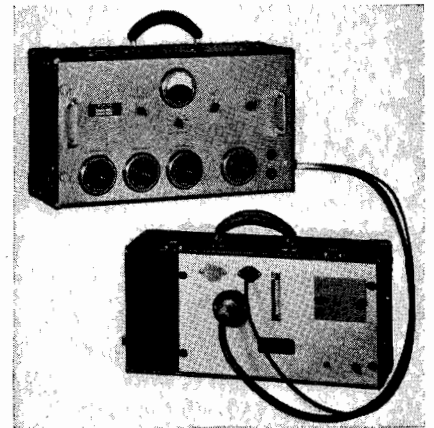

Fig. 6. The AP3-18 remote equipment (Remler) as set up for use.

Stabilized feedback is used to obtain high-fidelity characteristics. The output of the amplifier is fed through an isolation pad to the output key-switch—operation of which allows the program to be fed to either of two telephone lines (while the other line is connected to a handset). An interesting feature of this pad is that alternative connections of 600 ohms and 150 ohms output impedance are provided. Use of the latter, i.e., intentional mismatch, provides an equalizing effect tending to compensate the frequency characteristic of the line. Also across the output of the amplifier is a volume indicator of the standard rectox type. A rotary-type switch permits the zero reading on the meter to be set at levels from -4 db to +6 db. The power-supply circuits are conventional, with the exception that a circuit is provided such that the VI meter may be used to check voltages.

The arrangement of the controls, as well as the constructional features, of the amplifier unit will be more or less

evident from the several views shown. The four faders and the master gain control are, of course, arranged along the lower edge of the unit. Above, at the left, are the VI range switch and the meter lamp switch. Above, at the right, the telephone switch and filament power switch. Microphone input receptacles are on the left side of the unit, output and power-supply terminals on the right. There are two jacks for monitoring headphones, so that both the operator and the announcer may listen to the program as transmitted.

Type OP-5 (RCA): The OP-5 amplifier is another unit designed very much along the network lines. The facilities provided are much the same as those of the unit previously described, and even the arrangement of controls will be found to be quite similar—the only important difference being the provision of a meter switch (for checking individual plate currents and tube



Fig. 7. The Type 2A equipment (UTC). Amplifier is in upper case, power supply in lower case.

voltages) and of a filament rheostat (Fig. 4-A).

In other respects the OP-5 amplifier shows marked differences. The unit is intended only for battery operation. Space is provided for the batteries within the amplifier case, making the equipment complete in itself, with the exception, of course, of microphone and cables. The method of mounting batteries can be seen in the rear view (Fig. 4-B). The whole unit is only 11¾ inches high, by 18¾ inches long by 8½ inches deep—and weighs, with batteries, only 36 lbs.

It is interesting to note the chain of developments which have entered into the design of this unit. The compact construction is made possible by the fact that only two small A batteries are required (as compared to the usual storage battery, or multiplicity of dry cells). The small batteries are made possible by the use of new-type tubes (RCA-1603's—a pentode-type tube with a filament requiring 1.1 volts at .25 ampere

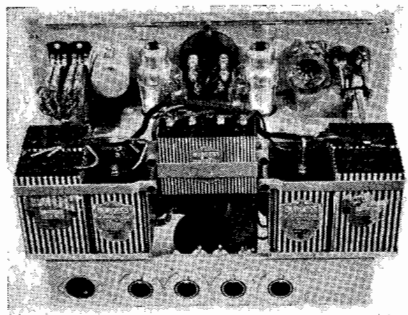

Fig. 4-B. Rear view of the Type OP-5 equipment (RCA).

—used as pentodes in the first three stages of the amplifier, and one of them as a triode in the output stage). The use of these relatively small-sized tubes has, in turn, been made possible by the application of feedback. The feedback circuit—by greatly improving the characteristics—allows use of components which would otherwise fall short of the required performance.

Type 12X (Collins): The 12X amplifier provides practically the same facilities as the previously-described units—with the exception that only three mixer inputs are provided. The circuits are, however, quite different. The most distinguishing feature is the provision of a miniature preamplifier in each of the microphone inputs. Each microphone channel thus consists of an input transformer feeding a 6J7G tube (triode-connected) followed by an output transformer feeding a low-impedance attenuator. This arrangement results in lower mixer noise, due to the higher level at which mixing is accomplished. Another advantage is the fact that the transformer inputs—through provision of multiple taps—provide for use of 30, 50, 200 or 250 ohm input impedances—or of a connection direct to the grid of the tubes. The tubes following the mixer are a 6C5G second stage, a 6C5G third stage, and two 6C5G's in the output stage, all triode-connected.

The amplifier unit proper of the 12X is contained in a metal cabinet 8½ inches high by 13 inches long by 9 inches deep (Fig. 5-A). All input and output connections are made by means

Fig. 8-B. The complete assembly of the Dynamote (Gates).

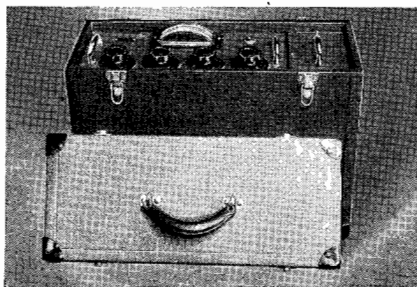

Fig. 4-A. Front view of the OP-5 battery-operated unit.

of receptacles located on the back of the unit. Access to tubes is provided by a hinged door in the top. For carrying, a plywood case is provided. This case, which has dimensions of 10 by 15 by 19 inches, provides space for microphones and cables, and also for permanent mounting of the ac power unit (Fig. 5-B). The equipment can also be used with battery power supply, the required voltages being 6.3 volts, 2.1 amperes, and 180 volts, 20 milliamperes.

Type AP3-18 (Remler): The AP3-18 amplifier provides facilities approximately the same as the units which have been described previously—and controls arranged more or less in the same manner. Three mixer-input connections—with the microphones feeding directly into the faders—and a master gain control, are provided. The tube lineup illustrates still another variation. The first and second stages employ 77's, triode-connected; the third stage is a 6A6, connected as a phase-inverter; and the fourth, or output stage a 6A6 in a standard push-pull connection. A special feature is the provision of two secondary windings on the output transformer. Individual switches connect these windings to line 1 or line 2, or terminate them when not being used. The volume indicator has a range switch providing operation at levels from -4 db to +6 db. High and low-impedance phonejacks are provided.

The equipment is mounted in two convenient carrying cases (Fig. 6). The amplifier panel is of Dural, and is drilled for mounting on a standard 19-inch rack, if this should be desired. The

Fig. 8-A. The amplifier unit of the Dynamote.



power-supply unit is mounted in the second carrying case. Additional space in one end of this case provides for carrying of cables, microphones, etc. A unique feature of this equipment is a circuit which allows a small a-c voltage to be supplied to the input circuit, for checking line continuity, levels, etc.

"JEWEL-BOX" EQUIPMENTS

The medium-size or "jewel-box" type equipments occupy a half-way position—both as to size, and as to facilities provided. The amplifier housings are smaller—the largest being 8 by 8 by 14 inches; the number of mixers is less—two or three; the VI meter is usually not illuminated, and has only one or two range taps; and only one output line is ordinarily provided. Generally speaking, the facilities provided are, however, sufficient for average station use and for most normal requirements. The price range—of the order of half that of larger-size equipments—is naturally an attractive feature.

Type 2A (UTC): The 2A amplifier is a good example of these jewel-box type equipments. It is a small-sized unit of attractive appearance, housed in a two-section carrying case—amplifier in one section, and power supply in the other. Two mixer-input positions are provided. Double primary windings provide input impedances of 30, 50, 200 or 250 ohms. The four-stage amplifier provides 95 db gain. Output impedances of 50, 125, 200, 250 and 500 ohms are available. The 200-ohm tap can be used to obtain equalization, as noted in a foregoing paragraph. The VI meter is arranged to serve also as a means for checking individual plate currents of the four tubes.

The power supply is contained in the lower section of the case (Fig. 7). Thus the equipment can be carried as a unit, but is so arranged that the power sup-

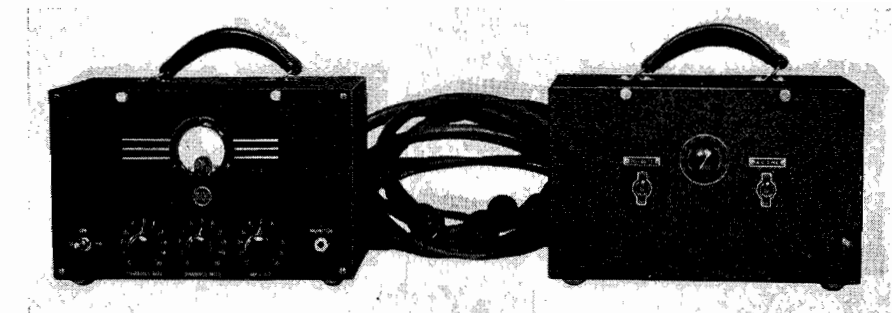

Fig. 9. The RCA 62-A. The regulated power supply is of a standard type.

ply can be detached and located at some distance from the amplifier section when in use. The equipment can also be used with battery supply. For this use the power unit may be removed from its case and batteries placed therein—or a separate battery box of the same dimensions can be maintained. The power supply required is 6.3 volts, 1.2 amperes, and 200 volts, 8 milliamperes.

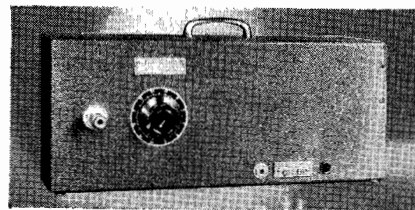

Fig. 12. Type 6-1 remote "Conditioner" (Gates) for fixed or portable use.

Dynamote (Gates): The Dynamote is an especially compact amplifier for remote pickup use—either with battery or a-c power supply. Three mixer input positions and a master gain control are provided. The unit is supplied with input impedance of 30 ohms or of 200/250 ohms (to order). Type 605 tubes are used in the first three stages, and a 6F6 in the output stage. A unique feature is a special VI meter.

This is of the edgewise-type having a scale 5 inches in length. It is highly damped to prevent peaks from creating unstable operations of the meter. The large-size scale is marked in decibels from -10 db to +6 db.

The amplifier proper is contained in a steel cabinet 7 inches high, by 14 inches wide and 8 inches deep (Fig. 8-A). A small power-supply unit (4 by 7 by 7 inches) is available for use with it. The two units may be placed in a carrying case (Fig. 8-B), which also has space for cables and microphones. Overall dimensions of the case are 20 by 12 by 10 inches. The equipment may be operated from batteries.

Type 62-A (RCA): The Type 62-A amplifier is another medium-size equipment of characteristic suitable for general use. It is contained in two small metal cabinets—amplifier and power supply, respectively—each 12 by 9 by 8 inches (Fig. 9). The facilities included are about the same as those of the two previously described equipments, but the circuits are quite different. The two input-positions feed into preamplifier stages utilizing 1603's, pentode-connected. Potentiometer-type fader controls are arranged to combine the outputs of these two preamplifiers into a three-stage amplifier utilizing a 1603 as a pentode, a 6A6 as phase-inverter, and a 6A6 as an output tube. The schematic diagram of this rather unusual circuit layout is shown in Fig. 10. The power-supply unit of this equipment is really surprising—in that it employs four tubes, and provides a regulated voltage output, something of a luxury in a portable equipment. The reason for this is presumably found in the fact that this is a standard-type power-supply unit (TMV-118-B), which needed only the addition of outlets to convert it for this use.

Fig. 10. Schematic diagram of the 62-A amplifier.

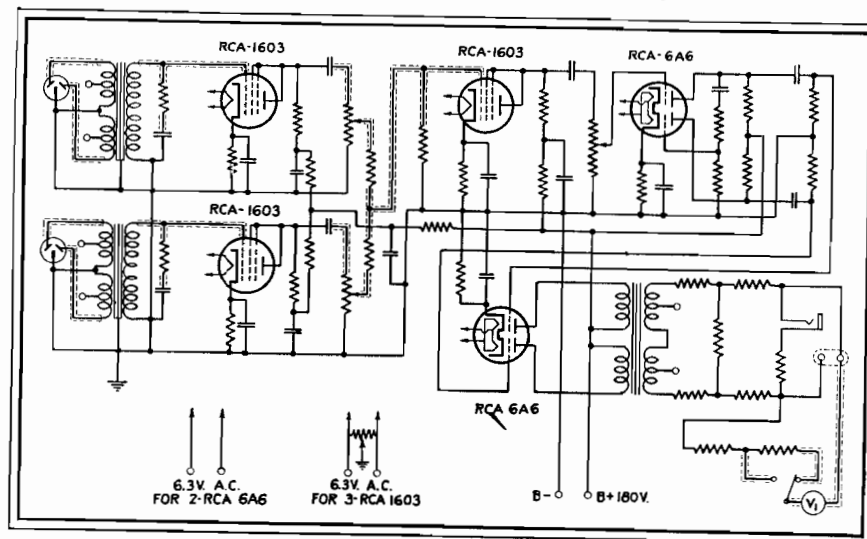

SMALL-SIZE EQUIPMENTS

In addition to the two general types of equipment described previously, there have recently appeared on the market several equipments of still different characteristics. These are small-sized equipments having a minimum of com-

(Continued on page 39)

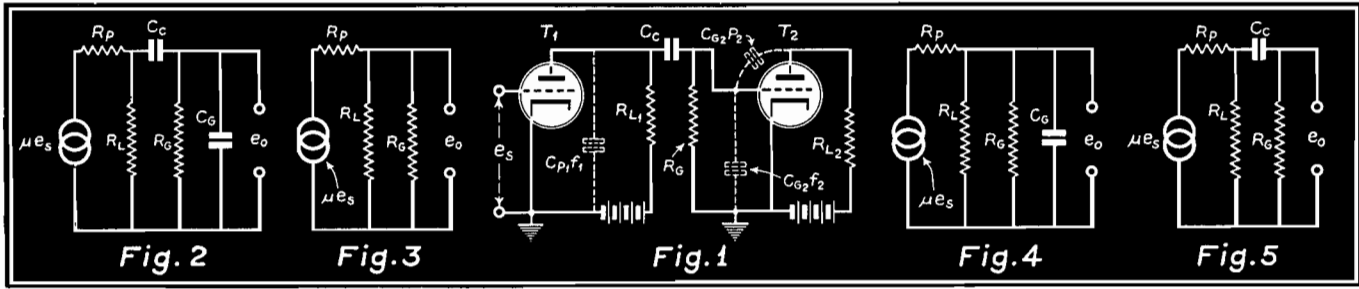

DESIGN OF RESISTANCE-COUPLED AMPLIFIERS

By **EDWARD J. RHOAD**

WQXR

THE DESIGN of resistance-coupled amplifiers is an old and, to a large extent, a neglected art. The process of selecting circuit components from response equations is well known, but at the same time so laborious that, for those who build an occasional amplifier, the task of design or even of checking assigned values is rarely attempted. On the other hand it is possible to design, for the desired limits as to gain and frequency response, an amplifier which will be more efficient and effective from the standpoint of circuit economy than the one arrived at by rule of thumb.

It is the purpose of this article to use the familiar derived response equations of a resistance-coupled amplifier or stage and specified response limits to arrive at satisfactory expressions for reasonably fast and accurate design. At the same time a set of curves will be plotted to further simplify design. The following work is based on information to be found in the majority of texts.

Figs. 1 to 5 show the basis of design for a specific stage of amplification. Fig. 1 is the normal circuit dia-

gram, with dotted lines representing the various stray and tube capacities which will affect frequency response. Fig. 2 shows an equivalent diagram in which C_G is the total of all tube and stray capacities. Fig. 3 is a simplified equivalent diagram for middle frequency gain, or for the maximum to be expected. Figs. 4 and 5 show the diagram simplified for high and low-frequency gain.

Since the bypassing effect of stray and tube capacities is the limiting factor of high-frequency response, it is on this that the design for upper limits must be based. These capacities may be lumped together as follows:

$$C_K = C_{p1f1} + C_{stray} + C_{K2f2} + (1 + a_2) C_{K2p2}$$

where a_2 is the gain of the following stage. In the case of a pentode or screen-grid tube the last element drops out. The stray capacities depend on the construction, and as an average is twenty mmfd. Resistors and wires up to two inches in length have about 2-3 mmfd capacity, long wires about four inches in length, running through or near chassis, have a value from 8-10 mmfd,

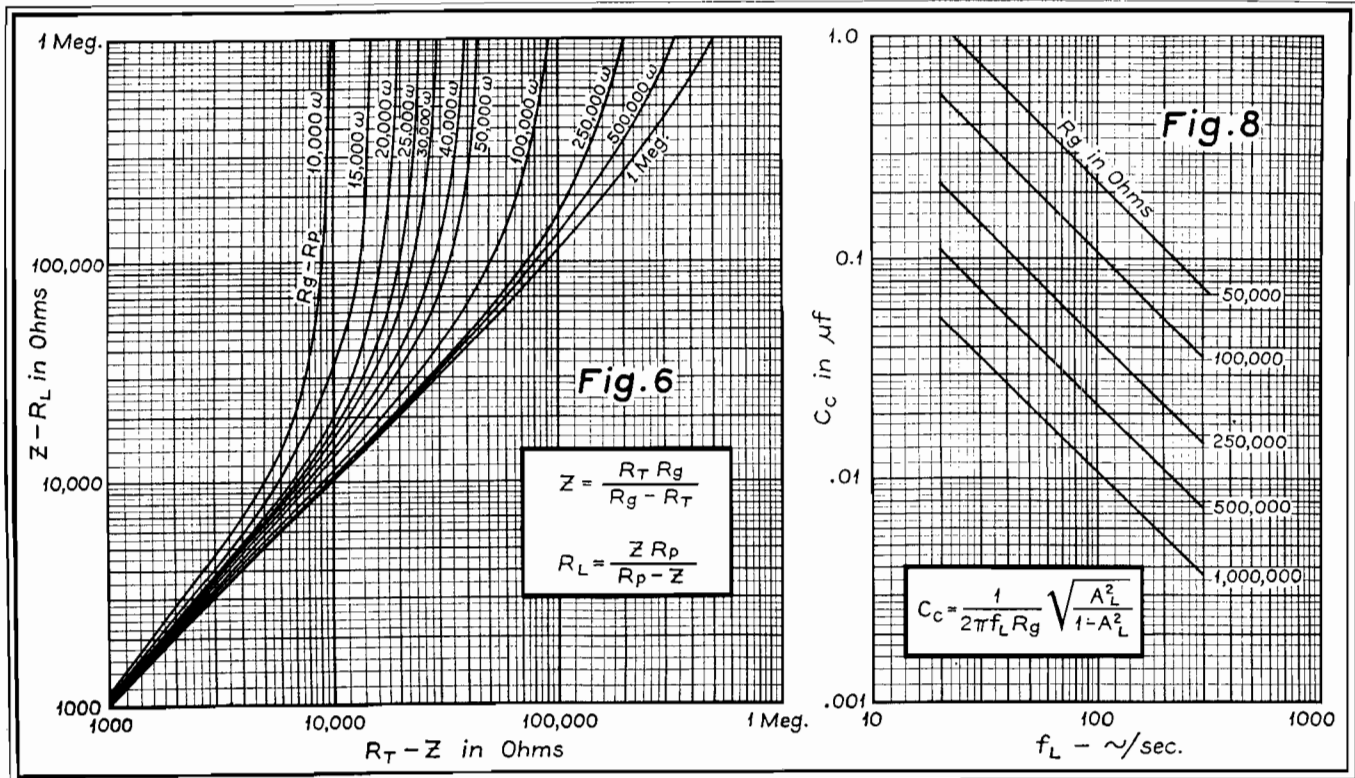

metal-cased coupling condensers spaced from ground by 1/8 inch of bakelite have about 15 mmfd, bakelite cased condensers about 5-7 mmfd, potentiometers about 15 mmfd, sockets about 1-2 mmfd capacity.

The derived equations for upper limit gain is

$$a_h = \frac{\mu R_1}{R_p \left(R_1 j\omega_h C_g + \frac{R_1}{R_g} + 1 \right) + R_1}$$

a_h = gain, high-frequency limit
 R_1 = load resistance
 R_p = plate resistance
 $\omega_h = 2\pi$ times upper limiting frequency
 C_g = lumped stray capacity

$$a_m = \frac{\mu R_1}{R_p \left(\frac{R_1}{R_g} + 1 \right) + R_1}$$

a_m = gain, middle frequencies

$$\text{Loss ratio} = \frac{a_h}{a_m} = A_h = \frac{\mu R_1}{R_p \left(R_1 j\omega_h C_g + \frac{R_1}{R_g} + 1 \right) + R_1}$$

$$= \frac{\mu R_1}{R_p \left(\frac{R_1}{R_g} + 1 \right) + R_1}$$

$$A_h = \frac{R_p \left(\frac{R_1}{R_g} + 1 \right) + R_1}{R_p \left(R_1 j\omega_h C_g + \frac{R_1}{R_g} + 1 \right) + R_1}$$

$$= \frac{1}{1 + \frac{R_p R_1 j\omega_h C_g}{R_p R_1 + R_p R_g + R_g R_1} + j\omega_h C_g \frac{R_p R_1 R_g}{R_p R_1 + R_p R_g + R_g R_1}}$$

$$\text{Lct } R_1 = \frac{R_p R_1 R_g}{R_p R_1 + R_p R_g + R_1 R_g}$$

$$A_h = \frac{1}{1 + \frac{R_t}{-jX_{cg}}}$$

$$\bar{A}_h = \sqrt{\frac{1}{1^2 + \left(\frac{R_t}{-jX_{cg}} \right)^2}} = \sqrt{\frac{1}{1 + \frac{R_t^2}{X_{cg}^2}}}$$

$$\bar{A}_h^2 = \frac{1}{1 + \frac{R_t^2}{X_{cg}^2}}$$

$$\bar{A}_h^2 X_{cg}^2 + \bar{A}_h^2 R_t^2 = X_{cg}^2$$

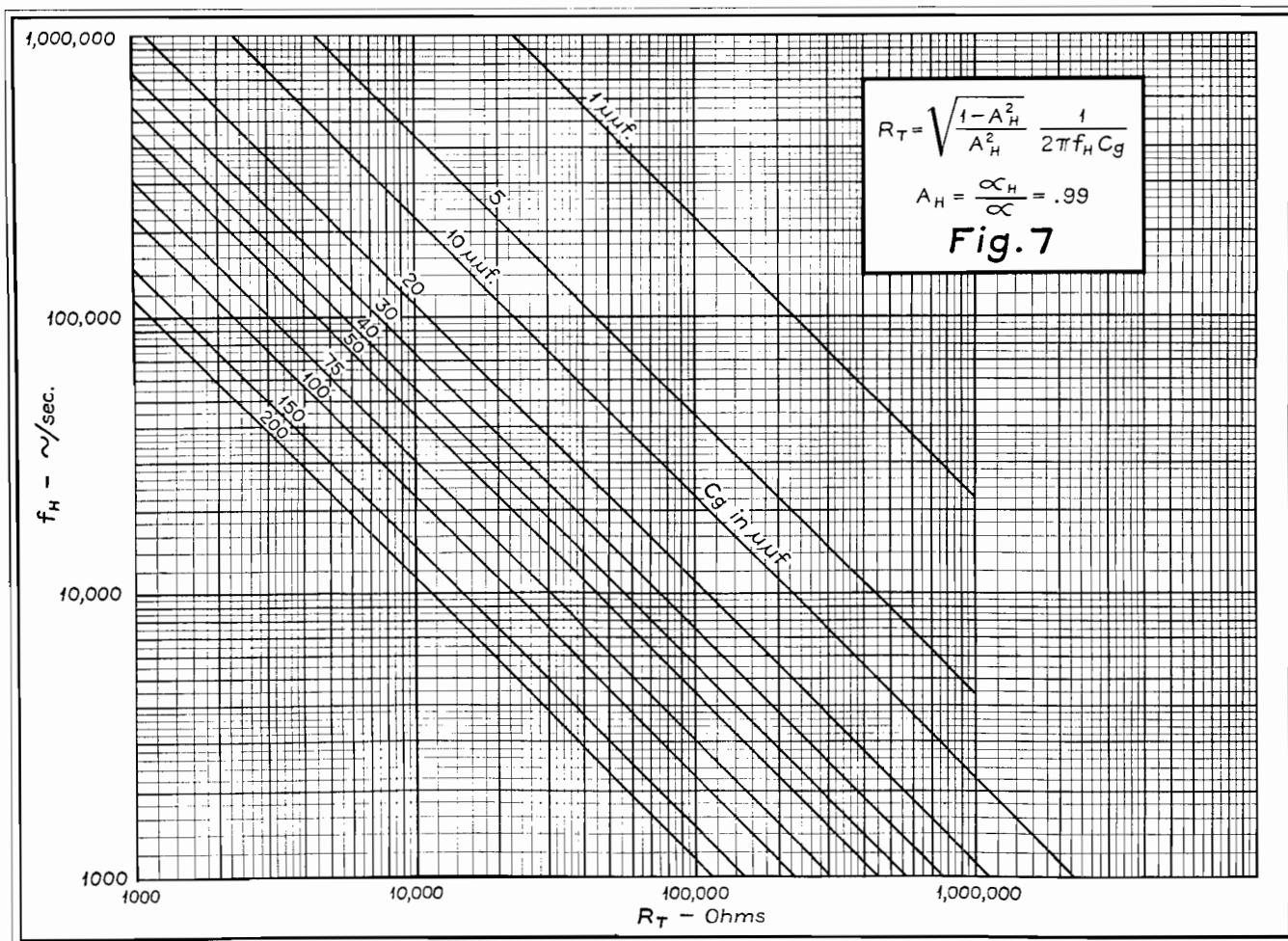

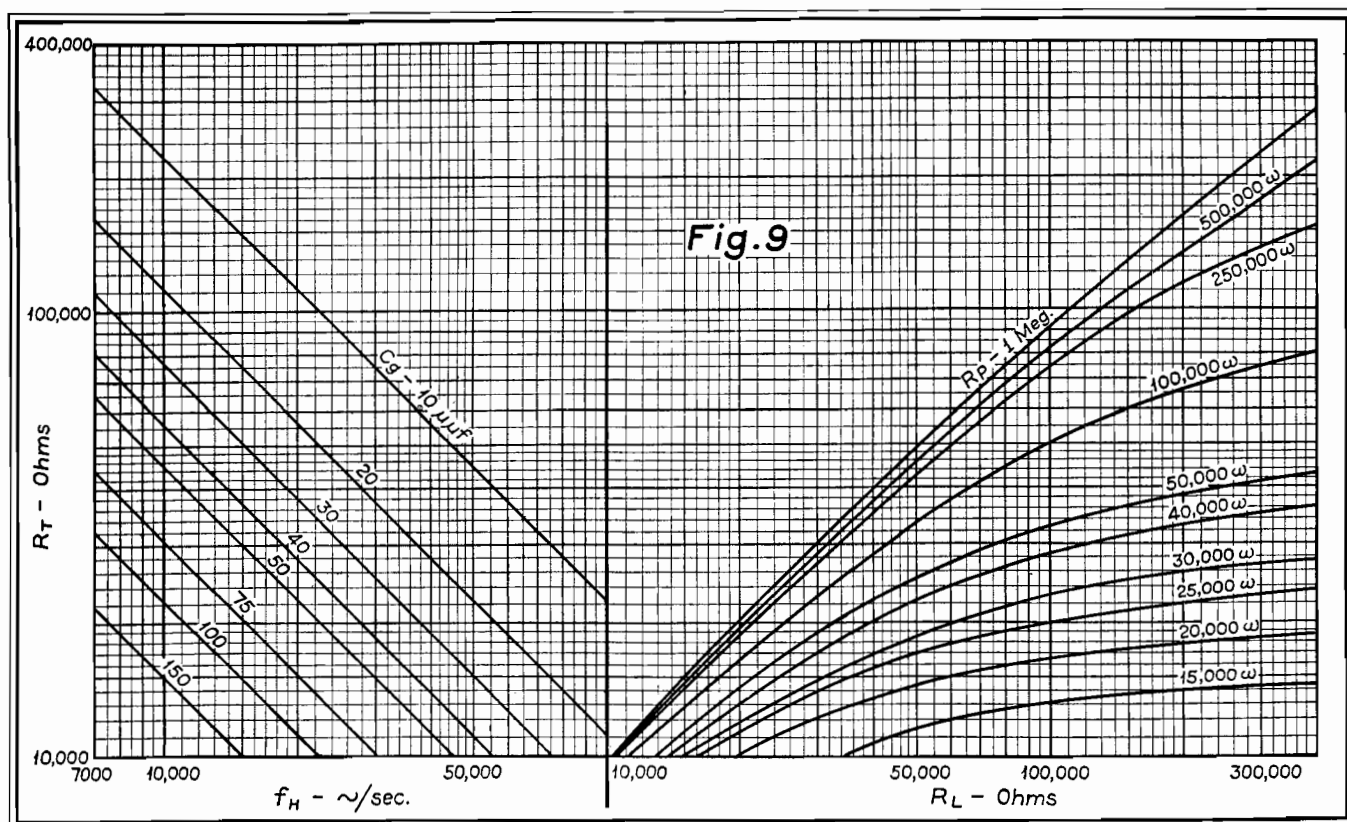

$$R_t^2 = X_{c_g}^2 \frac{(1 - A_h^2)}{A_h^2}$$

$$R_t = X_{c_g} \sqrt{\frac{1 - A_h^2}{A_h^2}} = \frac{1}{\omega_h C_g} \sqrt{\frac{1 - A_h^2}{A_h^2}}$$

From the above it is seen that, with ω_h and C_g held constant, R_t will vary inversely with A_h . This being true, if the actual value of R_t is equal or less than the calculated value, then the response of the stage of amplification will be within limits desired. Since R_p is fixed by choice of tube, and R_g by the following stage, R_1 is the variable circuit component.

In some cases R_1 can have any value (if R_g or R_p is less than R_t), in which case R_1 is chosen from the standpoint of available plate voltage.

Further simplifying the expression for R_t ,

$$R_t = \frac{R_p R_1 R_g}{R_p R_1 + R_p R_g + R_1 R_g}$$

$$\begin{aligned} \text{or } \frac{1}{R_t} &= \frac{1}{R_p} + \frac{1}{R_1} + \frac{1}{R_g} \\ \frac{1}{R_p} + \frac{1}{R_1} &= \frac{1}{R_t} - \frac{1}{R_g} \\ \frac{R_p + R_1}{R_p R_1} &= \frac{R_g - R_t}{R_g R_t} \\ \frac{R_p R_1}{R_p + R_1} &= \frac{R_g R_t}{R_g - R_t} = Z \\ R_1 &= \frac{Z R_p}{R_p - Z} \end{aligned}$$

R_g is usually much larger than R_p so that the following expression may be used without error

$$R_1 = \frac{R_t R_p}{R_p - R_t}$$

Turning to the design for low-frequency response, the following response equation is given:

$$a_1 = \frac{\mu R_1}{R_p \left(\frac{1 + R_1}{R_g} + \frac{1}{j\omega_1 C_c R_g} \right) + R_1 \left(1 + \frac{1}{j\omega_1 C_c R_g} \right)}$$

Combined with the expression for a_m and simplified, A_1 becomes

$$A_1 = \frac{1}{\left(1 + \frac{1}{j\omega_1 C_c R_g} \right) \left(\frac{R_p + R_1}{R_p + R_1 + \frac{R_p R_1}{R_g}} \right)}$$

The element

$$\frac{R_p + R_1}{R_p + R_1 + \frac{R_p R_1}{R_g}}$$

must always be equal to or less than 1, and examination of the expression for A_1 shows that any value less than 1 will further increase the value of A_1 . This being desirable, the factor can be neglected with the knowledge that the resulting design will be better than desired. This reduces the equation to

$$\begin{aligned} A_1 &= \frac{1}{1 + \frac{1}{j\omega_1 C_c R_g}} = \frac{1}{1 - \frac{jX_c}{R_g}} \\ A_1 &= \frac{1}{\sqrt{1^2 - \left(\frac{jX_c}{R_g} \right)^2}} = \frac{1}{\sqrt{1 + \left(\frac{X_c}{R_g} \right)^2}} \end{aligned}$$

(Continued on page 23)

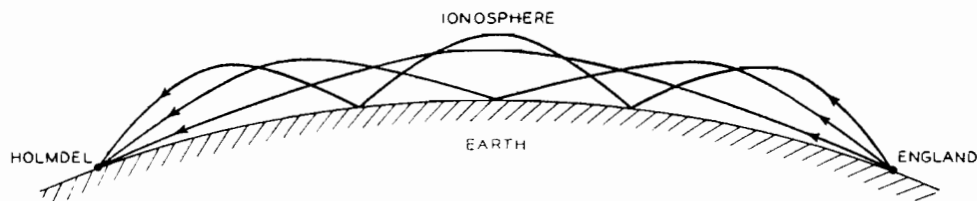

Fig. 1. A simplified conception of the short-wave transmission path between England and America.

PRINCIPLES OF THE MUSA*

By C. B. FELDMAN

Radio Research Department
BELL TELEPHONE LABORATORIES

FOR MORE than a decade, point-to-point short-wave radio services have employed directional antennas for both transmitting and receiving. A directional antenna at the transmitter increases the field intensity at the receiving location, while one at the receiver discriminates against noise. The effect of directivity both at the transmitter and the receiver is thus to improve the signal-to-noise ratio of a given circuit, and to permit operation under more adverse transmission conditions than would be possible without them—thus increasing the reliability of the circuit.

Antennas in present use on the longer circuits, such as that between New York and London, represent about the limit of fixed directivity. Further increase or "sharpening" of the directivity would seriously encroach upon the range of directions over which the wave paths vary in passing from the transmitter to the receiver. Although there is some variation both in horizontal and vertical angle of reception, that in the horizontal plane is usually much smaller and, as a result, of comparatively little importance.

The variation in the vertical plane has already been discussed.¹ The reasons for it are indicated in Fig. 1. Waves leave the transmitter over a range of vertical angles and thus reach the refracting layers of the ionosphere at various positions and angles. Only those components which reach the ionosphere at less than a certain critical angle are refracted back to earth. Of these only certain ones have directions such that they reach the earth at the receiving location. Even some of these portions of the transmitted wave may be lost by excessive attenuation, but as an overall result, there are generally several more or less discreet vertical angles at which

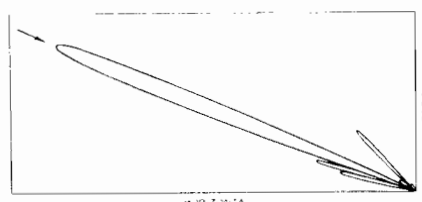

Fig. 3. Receiving characteristics of the experimental MUSA.

the signal may be received. These angles vary from time to time with variation in height of the refracting layers, and if the directivity of the receiver is not broad enough to cover the range of the most prominent signals, there will be

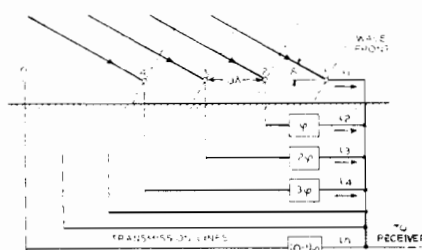
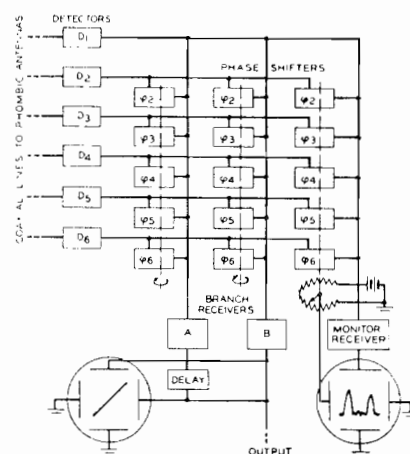

Fig. 2. Showing directive antennas and phase-shifting networks.

Fig. 4. Simplified block schematic of the MUSA system at Holmdel.



times when practically no signal is received even though the field strength is high enough for reception with a properly directed antenna.

Increased sharpness of directivity, however, results in a higher ratio of signal-to-noise, so that if the directivity of the receiver were made very sharp, and some method provided for changing its angle of reception to enable it to be kept pointed at one of the most prominent signals, reception would be greatly improved. With a number of such antennas separately directed, several signal components could after proper adjustment for their different transmission delays, be combined in a single receiver. It is just this that the MUSA does—the word MUSA standing for multiple-unit steerable antenna.

The MUSA consists of a number of similar and equally spaced directional antennas laid out along the great-circle direction of the transmitter. These antennas are not sharply directional in themselves, but are designed to receive over the normal range of vertical angles. The reason for the directive action of such an array will become apparent from a study of Fig. 2, where the circles represent the antennas, and the received signal is shown arriving at an angle with the ground. It is obvious that the signal arrives at antenna 2 before it does at antenna 1, or in other words, that the phase of the signal at antenna 2 leads that of antenna 1. Similarly the phase of the signal at antenna 3 is ahead of that at antenna 2 by the same amount, and so on for the entire array. As a result of the phase of the signal at antenna 2 will lead that at antenna 1 by some angle that may be called θ , while that of the signal at antenna 3 will lead that at antenna 1 by an angle 2θ , and so on for the entire array.

If the receiver is considered to be located at antenna 1, however, it is
(Continued on page 22)

*Condensed from *Bell Laboratories Record* for January, 1938.

¹*Bell Laboratories Record*, June, 1934, p. 305.

AMPLIFICATION PROBLEMS OF TELEVISION

By **F. ALTON EVEREST**

Instructor in Electrical Engineering
OREGON STATE COLLEGE

THE SHAPE of the signal resulting from the scanning of a television image is entirely arbitrary in nature. There is no method by which the exact frequency content of this television signal can be conveniently obtained because of the fact that the scanning of each line is a transient pulse differing from the next line. This results in a very complicated signal whose frequency content is continually shifting, defying close analysis. This paper presents a summary of the methods used in arriving at the approximate frequency requirements of typical television-frequency (or video) amplifiers and methods of correcting conventional resistance-capacitance coupled amplifiers to fill these requirements. It is appreciated that further development of the electron-multiplier may render this type of amplifier obsolete, but so far it represents the most satisfactory method of television-frequency amplification.

DETERMINATION OF FREQUENCY CONTENT OF SCAN LINE

If the television scanning device were scanning a white image, the output of this device would be of a rectangular wave shape. As the scanning spot approaches the edge of the white image area, the output current instantaneously rises from the quiescent value to some value corresponding to the white area as shown in Fig. 1. At the end of this scan-line the current will fall to its original zero value. It is seen, then, that the output wave of the scanning de-

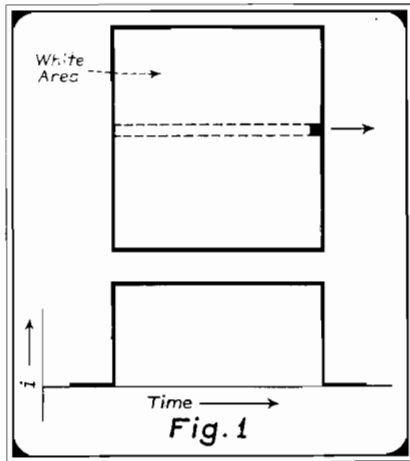

This paper, which was presented at the Pacific Coast Convention of the Institute of Radio Engineers at Spokane, Washington, August 1-2, 1937, gives a summary of the important, though not widely appreciated, factors governing television amplifier response.

vice for this image would be of a rectangular shape.

If this rectangularly shaped wave were re-current and periodic, it could be dealt with as a steady-state phenomenon. By means of the Fourier series,

$$f(\omega t) = b_0 + b_1 \cos \omega t + b_2 \cos 2 \omega t + b_3 \cos 3 \omega t + \dots + a_1 \sin \omega t + a_2 \sin 2 \omega t + a_3 \sin 3 \omega t + \dots \quad (1)$$

Any periodic function can be completely expressed, no matter how complicated the form, in terms of a group of sinusoidal and cosinusoidal waves of various amplitudes and of frequencies in integral-multiple relationship with the fundamental frequency. If the pulse

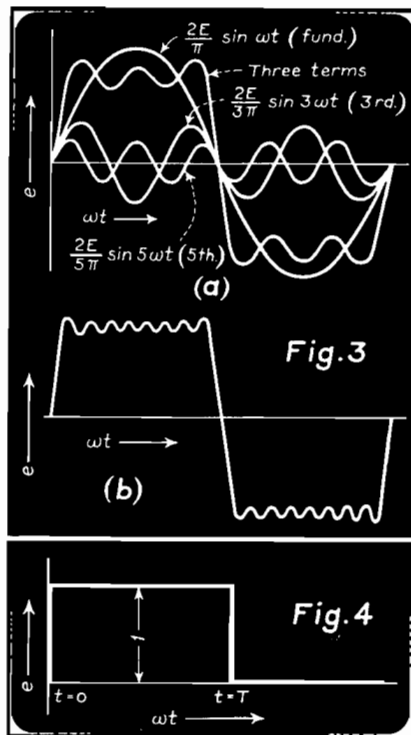

of Fig. 1 is considered as periodic, as the wave shape of Fig. 2-A, it can be changed to the symmetrical wave of Fig. 2-B by the addition of a constant term. The frequency of this rectangular wave

is $f_0 = \frac{\omega}{2\pi}$. An application of the series

of (1) to the wave of Fig. 2-B results in

$$e = \frac{2E}{\pi} \left[\sin \omega t + \frac{1}{3} \sin 3 \omega t + \frac{1}{5} \sin 5 \omega t + \dots \right] \quad (2)$$

Here it is noted that only the odd harmonic terms appear as would be expected if positive and negative portions of the wave are identical. Fig. 3-A shows the various terms of (2) plotted against frequency. The

$$\frac{2E}{\pi} \sin \omega t$$

term represents the fundamental frequency, f_0 . The

$$\frac{2E}{3\pi} \sin 3 \omega t$$

term is the third harmonic, the next the fifth and so on to the n th term. By adding algebraically the fundamental and the third and fifth harmonics, the wave labeled "three terms" is obtained. It is seen that the rectangular shape is being formed, but the inclusion of only three terms leaves much to be desired. If all of the infinite number of fre-

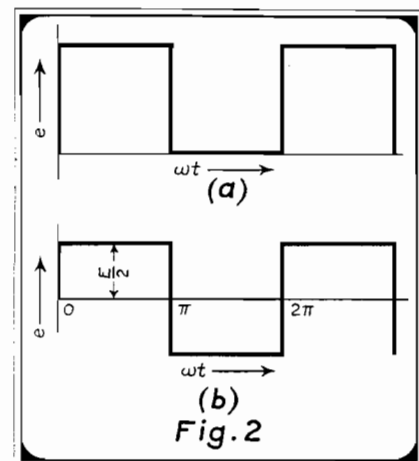

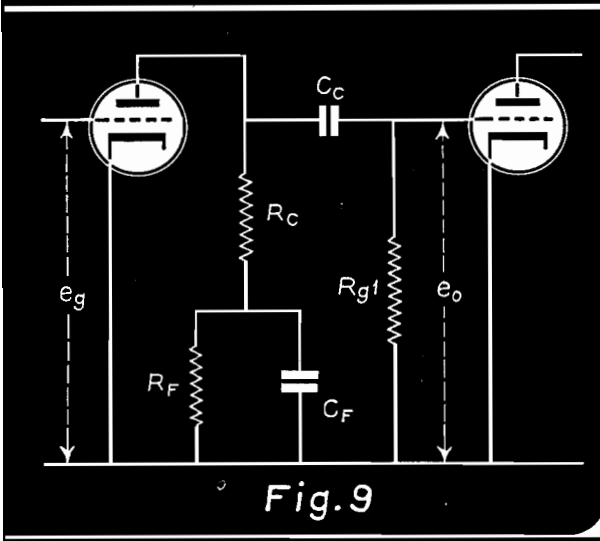
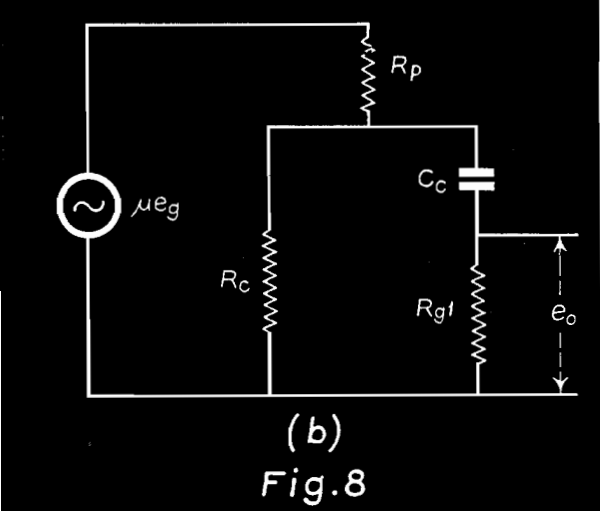
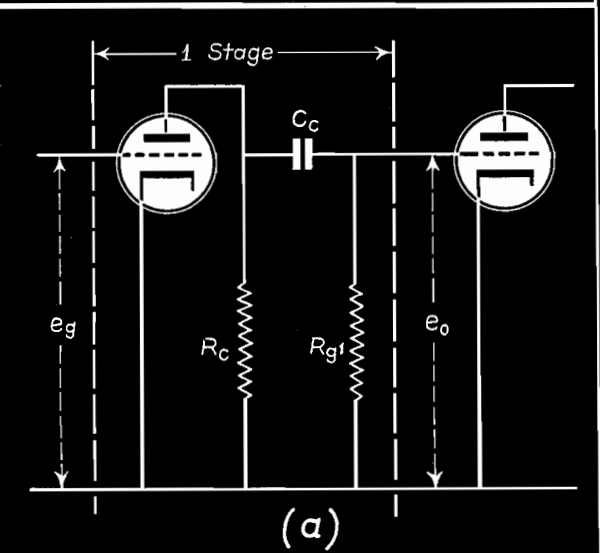
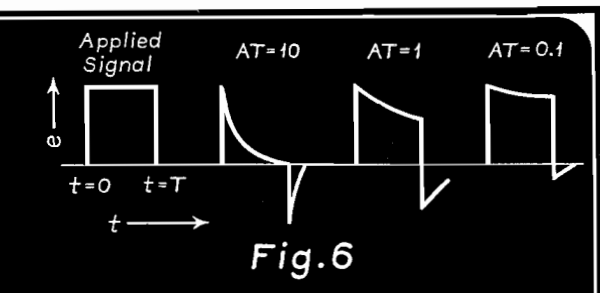

quency components are included, the perfect rectangular wave is obtained. If an amplifier is to amplify this steady-state rectangular wave, its ability to reproduce the perfectly square top is dependent upon its ability to amplify the high-frequency components of the wave. Any finite upper limit will prevent perfect reproduction of the wave shape. If an amplifier were capable of amplifying only the first 15 terms, the perfectly flat-topped original of Fig. 2-B would be distorted to that of Fig. 3-B.

The above analysis is based upon a wave that has reached steady-state conditions. The wave shapes of television signals never obtain this state, but rather are continually shifting and changing. The steady-state analysis, obviously, will not hold for transient signals such as are encountered in television work. However, some such analysis applicable to the transient pulses is necessary to ascertain their frequency content. The Fourier series will not hold for it is based upon steady-state conditions.

An extension of the Fourier series, the Fourier integral, is a tool for apply-

lasting from $t=0$ to $t=T$ can be investigated by regarding the pulse as periodic, applying the Fourier series, and multiplying the series by the above unit function expression which is zero for all values of t except the actual duration of the transient pulse.

Fig. 5 shows graphically the results of applying the above line of reasoning to rectangular waves of various types. Fig. 5-A is the steady-state wave already analyzed (neglecting the d-c component) which is included for comparison purposes. As was found, the frequency components are localized entirely at discrete harmonic frequencies, there being absolutely no energy existing between the odd harmonic frequencies. The greatest amount of energy is at the fundamental component, f_0 , the pure sine wave which has the same frequency as the square prototype. The energies of the other components are inversely proportional to the frequency, that is, the amplitude of the 5th har-

monic component is $\frac{1}{5}$ that of the fundamental, etc. In this and subse-

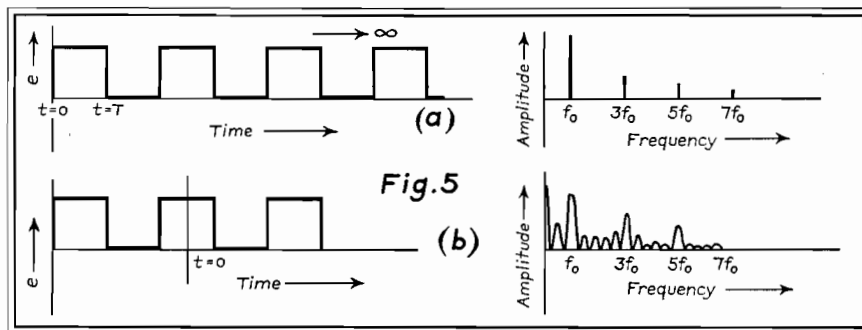

ing the series to transient pulses. The frequency content of transient pulses can be obtained by multiplying the Fourier series of the pulse regarded as a steady-state wave by the Fourier integral expression for the unit function for the time limits in question. The unit function is an impulse that has zero amplitude up to a certain time, $t=0$, rises to a value of unity instantaneously, then falls back to zero at some time T . The Fourier integral of this unit function therefore provides a multiplier for the series for the pulse which is zero up to $t=0$ and after $t=T$, but between $t=0$ and $t=T$, the product will truly represent the transient. The Fourier integral for the unit function of Fig. 4 is

$$f(t) = \frac{1}{\pi} \int_0^{\infty} \frac{\alpha}{\omega} \left[\sin \omega T - \sin \omega (t - T) \right] d\omega \quad (3)$$

By means of this multiplier, the frequency content of any transient pulse

quency component sketches, all components are plotted as positive irrespective of their actual sign as we are interested only in their magnitude.

If, now, the frequency content of a limited number of rectangular pulses such as Fig. 5-B were to be examined, the frequency distribution would be found to be entirely different. The frequencies are grouped around the odd harmonic frequencies, but by no means is all of the energy concentrated at the discrete harmonic frequencies as was found for the steady-state wave of the same shape. While the wave of Fig. 5-A could be transmitted perfectly by an amplifier that would respond only to the discrete odd harmonic frequencies, the transient pulse group of three of these rectangular waves would require a continuous response from zero to infinity.

For the single rectangular pulse we find that the relative amplitude of the frequency components is as shown in Fig. 5-C. Here again the energies are



- R_p = plate resistance of the tube, ohms
- R_c = coupling resistance, ohms
- R_{g1} = grid-leak resistance, ohms
- C_c = coupling condenser, farads

Distortions resulting from the various values of AT are shown in Fig. 6. Taking representative values of

- $R_p = 1$ megohm
- $R_c = 10,000$ ohms
- $R_{g1} = 100,000$ ohms
- $C_c = 0.1$ microfarad

a value of $A = 91$ is found. The time T required to scan one line of a 441-line, 30-frame interlaced image is approximately 75 microseconds. The product AT for this amplifier is

$$AT = (75 \times 10^{-6}) (91) = 0.007$$

which is very much smaller than needed to give satisfactory results. In fact, it has been found that only for the transients of relatively great duration, is low-frequency cutoff of importance.

The effect of high-frequency cutoff upon the amplification of transient pulses is shown graphically in Fig. 7 where

$$K = \frac{R_c + R_p}{(R_c)(R_p)(C_1)}$$

and C_1 is the total of the various shunting capacitances to ground. Assigning a value of $C_1 = 11$ micromicrofarads to the representative amplifier just discussed gives a value of $K = 9.2 \times 10^6$. The product then becomes

$$KT = (9.2 \times 10^6) (75 \times 10^{-6}) = 690$$

which indicates that good amplification from the transient standpoint ordinarily is not difficult to obtain.

RESPONSE OF AMPLIFIERS TO STEADY-STATE SIGNALS AND METHODS OF CORRECTION

Low Frequencies

Fig. 8-A shows a schematic wiring diagram for a conventional resistance-

capacitance coupled amplifier. This can be represented to a high degree of accuracy by the equivalent circuit of Fig. 8-B. It will be noticed that the equivalent generator voltage, μe_g , is impressed across the network including the plate resistance. The larger this plate resistance the lower will be the portion of μe_g that will appear in the external circuit to be impressed upon subsequent stages. The output voltage e_o will be diminished by any drop across the coupling condenser, C_c . At the low frequencies where the reactance of C_c becomes appreciable, the portion of the voltage appearing across R_{g1} as e_o is decreased.

The stage gain of the R-C coupled amplifier at the low frequencies is given by

$$\text{Stage Gain} = \frac{1}{\sqrt{1 + \frac{1}{\omega^2 T^2}}} \quad (4)$$

where

$$\text{Max. Amp.} = \left(\frac{1}{1 + \frac{R_p}{R_c}} \right)$$

- R_p = plate resistance of tube, ohms
- R_c = coupling resistance, ohms
- $\omega = 2\pi f$, f being frequency in cycles/sec
- $T = \text{time constant} = C_c R_{g1}$
- C_c = coupling condenser, farads
- R_{g1} = grid-leak resistance, ohms

An examination of (4) will show that the low-frequency response is determined entirely by T, other things remaining the same. The same time constant, and hence the same response, can be obtained by using countless com-

binations of C_c and R_{g1} . As long as the product is constant, the response will remain the same. The physical meaning of T lies in the fact that the condenser C_c will discharge through R_{g1} to 37% percent of its original value in T seconds.

The phase shift due to the coupling condenser is given by

$$\phi = \tan^{-1} \frac{1}{\omega T} \quad (5)$$

Phase shift at the lower frequencies is very important, corrections for it sometimes justifiably taking precedent over amplitude distortion. Phase shift at the low frequencies results in actual displacement of parts of the picture while amplitude distortion results only in false light intensities.

The loss in amplification at the low frequencies can be compensated by inserting some network in series with the coupling resistor whose impedance will increase as the frequency is decreased. This will increase the portion of μe_g appearing across R_c and compensate for the fact that the reactance of C_c increases, tending to decrease e_o . Fig. 9 shows a network R_F-C_F in series with the coupling resistor whose impedance increases as the frequency becomes less. The size of the elements are chosen so that at moderate frequencies, C_F short circuits R_F , removing it from the circuit in effect. As the frequency is lowered, the reactance of C_F increases, causing the total impedance of the R_F-C_F combination to increase. Fortunately, the phase shift of this correction network is in the opposite direction to that of the coupling condenser, thereby correcting for phase as well as amplitude distortion.

Fig. 10 shows the low-frequency response characteristics which were calculated for a typical pentode stage. These calculations are very laborious unless

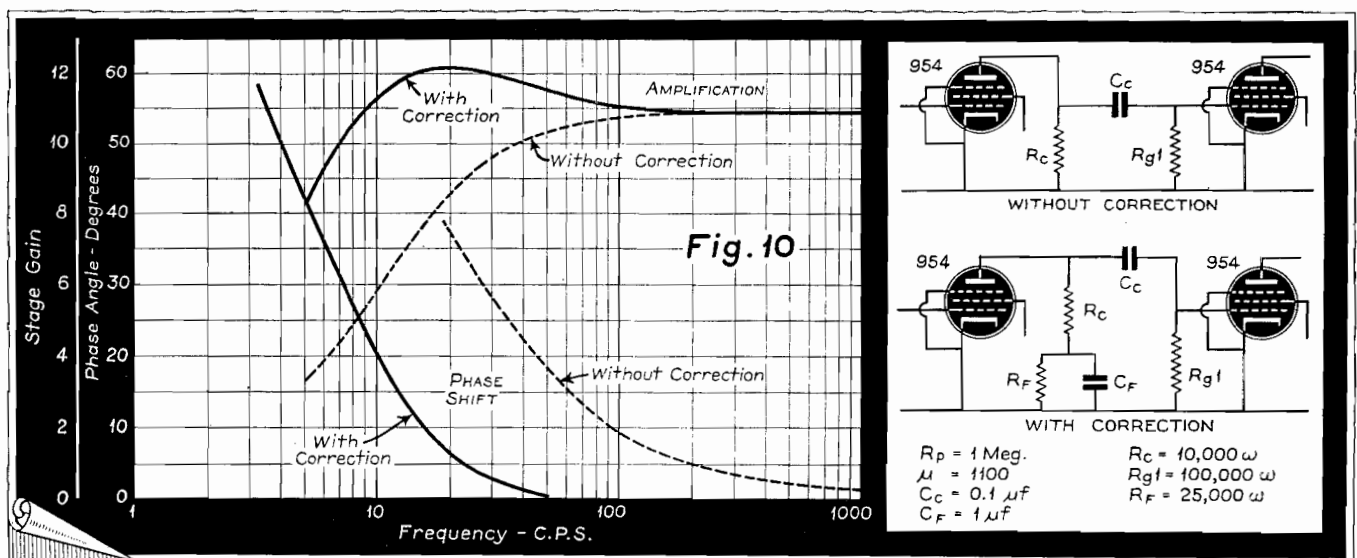

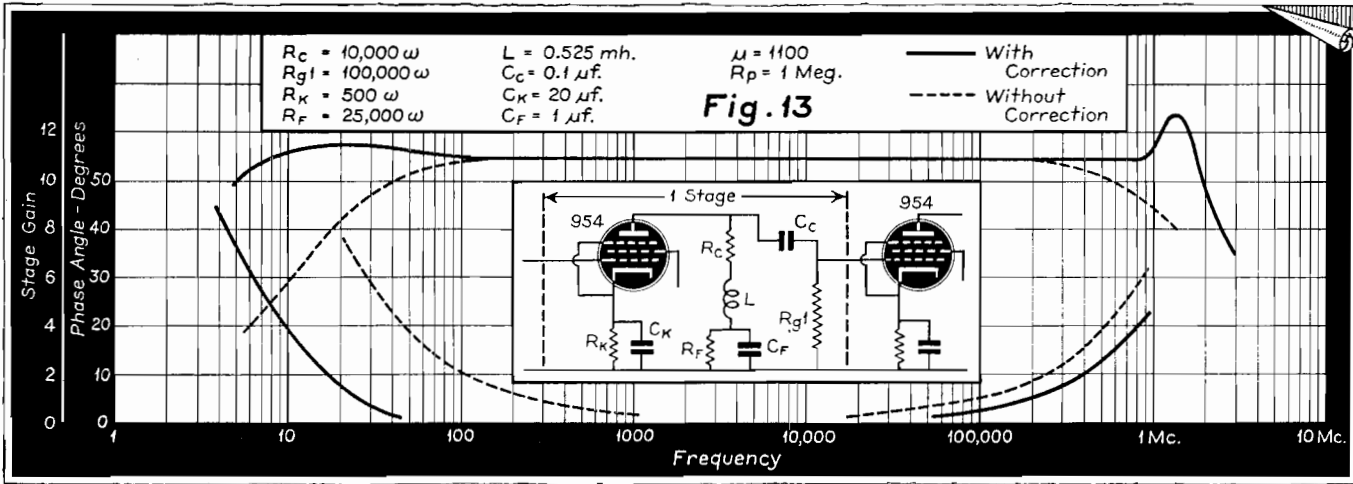

some graphical method such as presented by O. E. Keall⁹ is used.

The value of the time constant T has certain limitations. The larger is T the better is the low-frequency response, but certain things arise which make the use of too high values of T undesirable. If the grid is swung positive at all, even for a very short time, the resulting grid current renders the tube inactive until entirely drained off. Quick manipulation of the volume control can cause surges which may render the amplifier inoperative for some time. The size of the grid leak resistor is limited by the input impedance of the tube which it must parallel, and the bulkiness of a large coupling condenser and its associated shunt capacitance to ground, all go together to limit the value of T . Experience has indicated⁹ that $T = 0.01$ is about the largest satisfactory value. This value of T does result in low-frequency attenuation which must be corrected by the method shown.

High Frequencies

Fig. 11-A shows a simple R-C coupled amplifier. C_1 is the output capacitance of the first tube and C_2 is the input capacitance of the second, plus the stray wiring capacitances which always exist in greater or less degree. The equivalent circuit accurate for high frequencies is shown in Fig. 11-B. The coupling condenser C_c is essentially a short circuit at these frequencies and is therefore omitted. The capacitance C is the total shunting capacitance to ground, including both C_1 and C_2 . R_{g1} and R_c are in parallel and may be replaced by their equivalent resistance,

$$R_{eq} = \frac{R_p R_{g1}}{R_p + R_{g1}}$$

It will be observed that the shunting capacitance C is directly across the output terminals. At the frequencies where the reactance of C becomes small, only a small portion of $\mu_e r$ appears as the useful output voltage e_o .

The high-frequency response can be improved first, by minimizing the shunting effect of C . As R_{g1} (Fig. 11-A) is usually much larger than R_c , the value of R_c for a given shunting capacitance would largely determine the impedance across the terminals a-b. High values of R_c would result in high gain, but at the expense of wide response, for the effect of C would come into play sooner, causing poorer high-frequency response. The stage gain is given by

Stage Gain =

$$\left(\frac{1}{\sqrt{1 + \left(\frac{R}{X_c} \right)^2}} \right)$$

Max. Amp. =

$$\left(\frac{1}{1 + \frac{R_p}{R_c}} \right)$$

accurate if $R_{g1} \gg R_c$.

$R =$ Equiv. resistance of R_p , R_c , and R_{g1} in parallel

$$X_c = \frac{1}{2\pi f c} = \text{reactance of total shunting capacitance to ground.}$$

The amount of high-frequency improvement that can be expected by using moderate values of R_c is severely limited. The next step is to lower the shunting capacitances by lowering the grid-plate capacitance of the tube. The effect of this capacitance is magnified by the so-called "Miller effect" which causes it to be increased by $(1 + A)$ times where A is the actual amplification of the stage¹¹. This grid-plate capacitance can be lowered by the use of screen-grid tubes. With these tubes, the grid-plate capacitance is so low that the $(1 + A)$ multiplier has little effect.

For modern high-definition television-image amplification, a still greater high-frequency response must be obtained. This necessitates the neutralization of

the shunting capacitances by placing a small amount of inductance in series with the coupling resistor, R_c . This actually forms a parallel-resonant circuit whose resonant frequency is chosen to be higher than the highest frequency it is desired to amplify. A rough rule to follow for essentially constant amplification and negligible phase distortion is to use a value of R_c which is equal in ohms to the reactance of the shunting capacitances, C_s , at the highest frequency it is desired to amplify. The reactance of the correction inductance is then selected to be one half the value of the plate resistor, R_p . Other methods have been suggested for increasing the high-frequency amplification⁹, but the choke method has found greatest favor because of its simplicity. The calculation of the response using the correction choke is best done by complex algebra based upon the equivalent circuit of Fig. 12, although it is quite laborious.

Fig. 13 shows the steady-state response and phase shift of a typical television-frequency amplifier both with and without the correction devices. Knowing that this amplifier fulfills the conditions discussed under "Response of Amplifiers to Transient Signals" for the particular number of lines and frame frequency, and that the steady-state frequency is satisfactory for the definition desired, the amplifier stage shown in Fig. 13 will perform well as an amplifier of television frequencies.

CONCLUSIONS

(1) The scanning of a single line of a television image results in an irregularly-shaped transient pulse.

(2) The frequency content of a transient pulse may be found by the application of the Fourier series to the pulse regarded as periodic, and then the multiplication of this expression by the Fourier integral of the unit function existing between $t = 0$ and $t = T$, the duration of the pulse.

(3) The energy of components of typical television scan-lines is largely

(Continued on page 38)

Design . . NOTES AND

URNS RATIO OF CLASS B LINE-TO-GRID TRANSFORMERS

THERE SEEMS to be some confusion on the subject of transformers which couple a line to the grids of a Class B audio stage. In some instances, the principles of operation are not completely understood, whereas in others they are entirely overlooked. This misunderstanding usually arises when an amplifier with a 500-ohm output winding (see Fig. 1) is used to drive a Class B audio stage.

It is common practice, especially if the amplifier is located some distance from the Class B stage, to connect a line from the 500-ohm winding of the amplifier directly to a line-to-grid transformer, rather than to replace the output transformer on the amplifier with a regular driver transformer. This practice is perfectly correct, provided that the line-to-grid transformer is designed to operate with the specific output transformer on the amplifier.

An amplifier which is ordinarily used for p-a work is not suitable for use as a driver unless a change is made in the operating conditions of the power stage. As an amplifier, the plate-to-plate load of the output stage is fairly low, so that the power output is a maximum with a reasonable amount of distortion; this plate-to-plate load is constant throughout the audio cycle. However, when the amplifier is used as a driver, maximum power output is not the prime consideration; the plate-to-plate load is not constant throughout the cycle but depends upon the Class B grid swing. In other words, the driver is called upon to deliver only a limited amount of driving power which must be delivered to a varying plate load. It is necessary, then, to increase the value of the plate-to-plate load in order to provide a source of good regulation, since the higher the ratio between the plate-to-plate load and the plate resistance of the driver tube, the better will be the regulation.

In order to obtain maximum power output, the plate-to-plate load in ordinary power-amplifier design is fairly low. In the case of push-pull 2A3's it may be 3000 or 5000 ohms; however, when used as drivers, the 2A3's should have a plate-to-plate load two or three times greater. Since the line-to-grid transformer (T_2 in Fig. 1) is connected to the output of the amplifier, it is the means of reflecting the Class B grid

impedance to the "500-ohm line" and hence to the plate circuit of the driver tubes. It is the function of this transformer T_2 , since the ratio of T_1 is fixed, to reflect a high plate-to-plate load of such a value that the required Class B driving power is just developed with full excitation to the driver grids.

Suppose that an amplifier using 2A3's with a plate-to-plate load of 3000 ohms is to be coupled to a line-to-grid transformer through a 500-ohm line. If the 2A3's were to be coupled directly to the Class B grids through a regular driver transformer, suppose that the correct turns ratio of the driver transformer is 3.2 to 1. Then, when the amplifier is connected to the Class B grids through the line, the turns ratio from the total primary of the output transformer T_1 on the amplifier to one half the secondary on the line-to-grid transformer T_2 should also be 3.2 to 1. In other words, the correct driver transformer turns ratio must be maintained.

Assuming that the plate-to-plate load on the 2A3's is 3000 ohms, the turns ratio of the output transformer T_1 from the primary to the 500-ohm secondary is 2.45 to 1. The correct ratio of the line-to-grid transformer T_2 to give an effective overall ratio of 3.2 to 1 is 1 to .765. If the plate-to-plate load on the 2A3's had been 5000 ohms instead of 3000 ohms, the turns ratio of the line-to-grid transformer T_2 would have been 1 to .98 in order to preserve the overall ratio of 3.2 to 1. It may be seen from this that the correct turns ratio of the line to Class B grid transformer is entirely dependent upon the turns ratio of the output transformer with which it is used, and that the so-called 500-ohm line is merely a connecting link between the two transformers.

Frequently some designers make the mistake of designing a line to Class B grid transformer on the sole basis of the so-called 500-ohm line. To give a concrete example, let us assume that it is necessary to design a line-to-grid transformer to couple from the above amplifier when the only known condition is the fact that the output of the amplifier is 500 ohms. Suppose that the Class B stage consists of a pair of 830-B's. The average driving power required by the 830-B's is 6 watts, and the peak grid swing is 135 volts. The minimum grid impedance is thus 1500 ohms. The turns ratio of the line-to-grid transformer on the basis that the impedance of the line is 500 ohms would be 1 to 1.73. This would give an effective overall ratio of 1.41 to 1 instead of the correct value of 3 to 1. This change in effective ratio would result in poor driver regulation. Actually, the impedance of the "500-ohm line" with the correct ratio is 2250 ohms at the peak of the wave, and the average value over the entire cycle is much higher. The plate-to-plate load on the drivers in the case of the 3 to 1 ratio is 13,500 ohms, whereas with the incorrect ratio the plate-to-plate load is the original value of 3000 ohms.

Less driver excitation is required in the case of the 3000-ohm load, and for this reason it may be supposed that the lower effective ratio is more satisfactory. However, with the lower plate-to-plate load, the driver distortion is much higher.

In actual practice, the turns ratio of the line-to-grid transformer is increased from the theoretical value to allow for losses in the transformer and to allow the driving power to be developed well below the grid-current

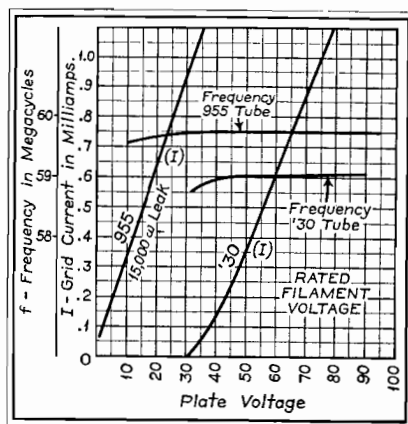

Left: Fig. 2. Graph of measurements made on typical 30 and 955 tubes.

Below: Fig. 1. Illustrating an amplifier with a 500-ohm output winding driving a Class B audio stage.

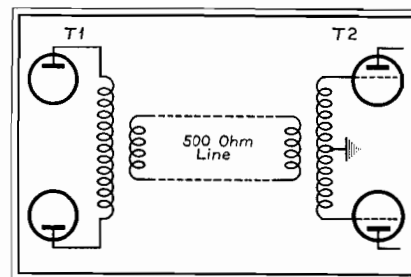

COMMENT . . Production

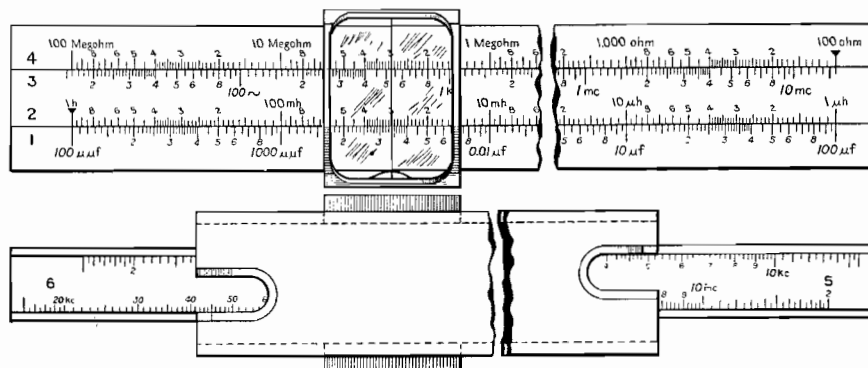

Front and rear view of slide rule. Notice in rear view that only Scale 5 is visible when rule is to right, and that only Scale 6 is visible when rule is extended to left.

point of the drivers. The ratio should be approximately ten to fifteen percent above the theoretical value.

Since the output transformer on the amplifier was designed originally for a lower plate-to-plate load, the overall frequency response of the amplifier will suffer slightly due to the higher value of the plate-to-plate load. However, if the output transformer is a good one with adequate primary inductance, this change in frequency response is usually slight enough to be neglected.

DOUGLAS FORTUNE

RADIO SLIDE RULE

A NEW slide rule for radio engineers has recently been made available. The rule was designed by Mr. W. M. Perkins, of the Commercial Engineering Department of National Union Radio Corporation, for use in connection with engineering work being carried on under his supervision.

The purposes of the rule are to permit the rapid determination of the following: (1) capacitive reactance when capacity and frequency are known, (2) inductive reactance when inductance and frequency are known, and (3) resonant frequency when capacity and inductance are known. As a corollary in each of these three cases, the determination of the unknown quantity, when any two of the three quantities are known, may be readily accomplished.

The conventional slide rule solutions of these problems have in general two drawbacks: namely, the necessity for several settings to find the answer, and no provision for determining the decimal place in the final answer. The radio slide rule, however, has been de-

signed to overcome these limitations, providing answers with only one setting of the slide with the position of the decimal place automatically indicated.

The range of scales has been chosen so as to include the major portion of the values in which the average radio engineer is interested. The ranges are:

Scale 1—Capacity, 100 mmfd to 100 mfd.

Scale 2—Inductance, 1 mh to 1 h.

Scale 3—Frequency, 16 cycles to 16 mc.

Scale 4—Reactance, 100 ohms to 100 megohms.

Scale 5—Resonant frequency, 16 cycles to 16 kc.

Scale 6—Resonant frequency, 16 mc to 16 kc.

As shown in the accompanying illustration, four of the scales appear on the front of the rule properly identified by numbers at the left. Scales 5 and 6, on the back of the slide and visible through the rear windows, are used in conjunction with Scales 1 and 2 for the solution of resonant frequency problems. It will be noted that when the slide is extended to the right only Scale 5 is visible in the window, and, conversely, when the slide is extended to the left only Scale 6 is visible. This arrangement automatically avoids confusion in selecting the proper frequency scale.

ULTRA-SHORT-WAVE TELEPHONE TRANSMITTERS

SINCE CRYSTAL-CONTROL at ultra-short wavelengths is almost out of the question, especially for portable transmitters, ordinary self-excited oscillators are used. It is necessary to exercise considerable care in the design of such oscillators if

the frequency emitted by the transmitter is to be kept steady.

The first consideration for a self-excited oscillator for use at ultra-short waves is the selection of the proper tube for the purpose. Several types of tubes are possible for this service, such as the ordinary 201-A, CG-1162, 30, 12A, 56 and others, but ordinarily, for low-power use, the 30 would be selected because it will readily oscillate and because its filament requires a minimum current drain. The 30 is perhaps even more popular than the 955 because of its comparatively small cost and lower filament current and voltage. In spite of the fact that the 955 requires a higher filament voltage and current, it nevertheless has other advantages for telephone work. Where power output is not important, the 955 will operate on much lower plate voltages than the 30 or any other of the tubes for use below 5 meters.

The graph of Fig. 2 shows some interesting measurements made on a typical 30 and a 955 tube. This graph shows that an average 30 will start oscillating when the plate voltage reaches about 30 volts, while the 955 will start oscillating with as little as a 1½-volt dry cell on the plate. The graph also shows another important consideration for telephone work, the change in frequency of oscillation when the plate voltage of a typical oscillator employing each tube is varied. When the plate voltage on an oscillator employing a 30 tube reaches about 40 volts, the frequency of oscillation changes rapidly as the plate voltage is reduced. And, the tube will stop oscillating when the plate voltage reaches about 30 volts. When a 955 tube is used in a similar circuit, the plate voltage can be reduced to about 25 volts before this change in frequency starts, and the plate voltage can be reduced to a very low value before oscillations stop. The 955 is a much better tube for low plate-voltage work, and the reduction in the weight of the necessary B batteries would probably more than compensate for the filament battery. The filament drain is more but the batteries are very inexpensive.

The Heising scheme of modulation, in which an iron-core choke is used in the plate circuit of the oscillator, is very popular. The graph referred to suggests that the plate-voltage change which takes place in such oscillators

(Continued on page 39)

PROGRAM OF THE BROADCAST ENGINEERING CONFERENCE

February 7-18, 1938 • • • Ohio State University

THE Department of Electrical Engineering of the Ohio State University is sponsoring a conference or short course on Broadcast Engineering during the period of February 7 to 18, 1938. The purpose of this conference is to bring together leaders in the industry and practicing engineers from all parts of the United States and Canada in a discussion of some of the most important technical problems.

The program will include three topics each day. A period of two hours will be assigned to each topic. The first hour will be devoted to a formal lecture by the leader, and the second hour will be a round-table discussion participated in by all.

The men who have consented to act as leaders will be recognized by all broadcast engineers as outstanding authorities on the topics which they are to discuss.

An important feature of the Conference will be the opportunities for informal association and discussion.

The number of men who can be accommodated at the conference is limited so that all attending may benefit from

TIME	9 A.M. TO 11 A.M.	11 A.M. TO 1 P.M.	2:30 P.M. TO 4:30 P.M.
Monday Feb. 7	Field Strength Surveys J. F. Byrne Collins Radio Company	Coupling Networks W. L. Everitt Ohio State University	Studio Acoustics George M. Nixon National Broadcasting Company
Tuesday Feb. 8			
Wednesday Feb. 9	Ultra-High-Frequency Propagation H. H. Beverage Chief Research Engineer R.C.A. Communications, Inc.	Propagation of Broadcast Frequencies at Night J. H. Dellinger Chief, Radio Section Bureau of Standards	
Thursday Feb. 10			
Friday Feb. 11	Demonstrations of Phenomena of Interest to Radio Engineers W. L. Everitt		
Saturday Feb. 12			

the round-table discussion. For that reason an early registration is desirable. Information on registration, cost, living accommodations, etc., may be obtained from the Director of the Conference, Professor W. L. Everitt, The Ohio State University, Columbus, Ohio.

THE MUSA

(Continued from page 14)

obvious that the signals from the other antennas also suffer a phase shift in passing over the transmission line from the antenna to the receiver. If this phase shift for the signal from antenna 2 is called α , then that for antenna 3 will be 2α , that from antenna 4 will be 3α and so on. In general, α differs from θ , but it is possible to put a phase-shifting network in the transmission line for antenna 2 to produce a phase shift ϕ of such a value that the sum of θ , α and ϕ will be zero. Similar networks could be put in all the lines—that in the line to antenna 3 being 2ϕ in value and so on. When this is done the signals from all the antennas will be in phase at the receiver and the combined signal will be equal to their sum.

Since the angle ϕ is equal to the difference between θ and α , and since θ varies with δ , ϕ also will vary with δ . For any one value of ϕ , in other words, the signals at the receiver will be in phase for only one angle of reception. For other angles of reception the signals from the various antennas

(Continued on page 35)

SECOND WEEK—FEBRUARY 14-18

TIME	9 A.M. TO 11 A.M.	11 A.M. TO 1 P.M.	2:30 P.M. TO 4:30 P.M.
Monday Feb. 14	Broadcast Antenna Design George H. Brown Consulting Engineer	High Power Radio Frequency Amplifiers W. H. Doherty Bell Telephone Laboratories	Modulation and Distortion Measurements A. E. Thiessen General Radio Company
Tuesday Feb. 15			Indicating Instruments H. L. Oleson Weston Instrument Company
Wednesday Feb. 16			Snow Static Effects on Aircraft H. M. Hucke Chief Communications Engineer United Air Lines
Thursday Feb. 17			Aeronautical Ground Radio Station Design P. C. Sandretto Communications Engineer United Air Lines
Friday Feb. 18			

RIGHT: The 400-foot tower of W2XMN, erected near Alpine, N. J., by Major Edwin H. Armstrong, for carrying out experiments with his frequency modulation system using ultra-short waves.

BELOW: The transmitter house of W2XMN.

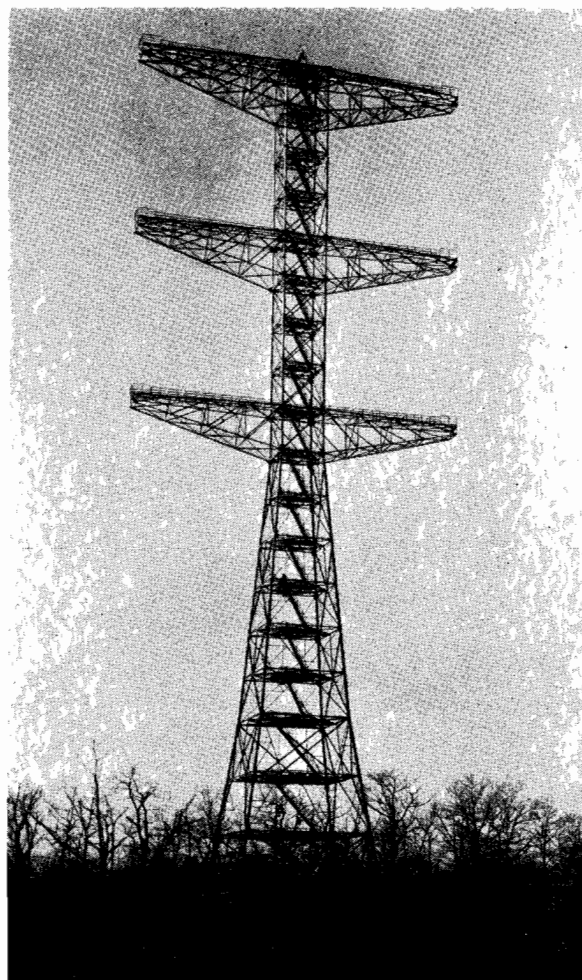
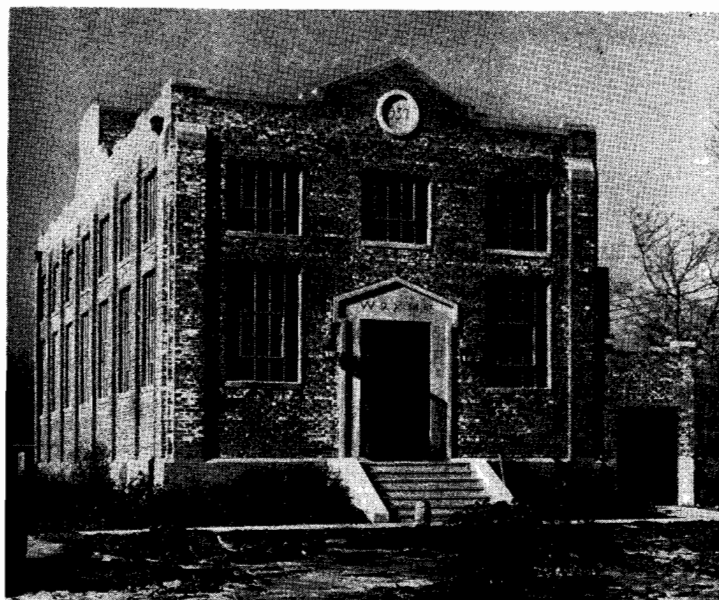

DESIGN OF RESISTANCE-COUPLED AMPLIFIERS

(Continued from page 13)

$$A_1^2 = \frac{1}{1 + \frac{X_e^2}{R_g^2}}$$

$$A_1^2 R_g^2 + A_1^2 X_e^2 = R_g^2$$

$$X_e^2 = R_g^2 \frac{(1 - A_1^2)}{A_1^2}$$

$$X_e = R_g \sqrt{\frac{1 - A_1^2}{A_1^2}} \text{ and } C_c = \frac{1}{\omega_1 R_g} \sqrt{\frac{A_1^2}{1 - A_1^2}}$$

To sum up, the equations used and the necessary known quantities are:

$\omega_1, \omega_h = 2 \pi$ times the low and high-frequency limits

$$A_l, A_h = \text{loss ratio, low and high} = \frac{E_{o1}}{E_{om}} \text{ or } \frac{E_{oh}}{E_{om}} \text{ or } \log^{-1} \frac{\text{db}}{20}$$

R_p, μ, C_{pt} of tube chosen for stage

a of following stage, and R_g, C_{gt} , and C_{gp} of its tube

C_{stray}

$$C_g = C_{p1t1} + C_s + C_{g2t2} + (1 + a_2) C_{g2p2}$$

$$R_t = \sqrt{\frac{1 - A_h^2}{A_h^2}} \frac{1}{\omega_h C_g}$$

$$Z = \frac{R_t R_g}{R_g - R_t} \quad \text{or } R_t = \frac{R_t R_p}{R_p - R_t}$$

$$R_1 = \frac{Z R_p}{R_p - Z}$$

$$C_c = \frac{1}{\omega_1 R_g} \sqrt{\frac{A_1^2}{1 - A_1^2}}$$

$$a = \frac{\mu R_1}{R_p \left(1 + \frac{R_1}{R_g}\right) + R_1} \quad \text{or } \frac{\mu R_1}{R_p + R_1}$$

The values of A_h and A_l can be chosen for a desired loss, 1 db being 0.89 or if close limits are required— as in an amplifier of several stages—then 0.99 may be used. Using the value of 0.99 a set of curves have been made up for a wide range of frequencies, capacities, and resistances. Fig. 7 gives R_t , knowing C_g and f_h . Fig. 6 gives the resistance of two resistances in parallel, and is used to find Z and R_1 . Fig. 8 gives the proper value of coupling condenser knowing R_g and f_1 . Fig. 9 is a composite of 6 and 7 for design covering the audio frequencies, neglecting R_g .

PRODUCTION DEVELOPMENT OF TELEVISION TUBES

IT HAS BEEN REPORTED that the only plant in existence six years ago, for the production of cathode-ray tubes, consisted of a few exhaust pumps in the basement of Allen B. DuMont's home. His initial missionary work and development, continued and augmented through the intervening period by the research laboratories of other concerns, has now put the cathode-ray tube on a production basis to meet the demands of radio and television. Within recent months, DuMont's laboratory space has increased to factory proportions. This change, also typical of other plants, has been accompanied by the substitution of machine and mass-production techniques for hand methods. (Fig. 1.)

SCREEN PRODUCTION

The evolution of screen-forming techniques is interesting, involving as it does the early uses of binding agents through succeeding stages to a sole reliance on inter-molecular forces between the fluorescent powders and their base.

Artificial willemite, or zinc orthosilicate (Zn_2SiO_4) as formed in an electric furnace by the fusing of zinc oxide, silica, an activator and flux, has been applied, first, by spraying with sodium

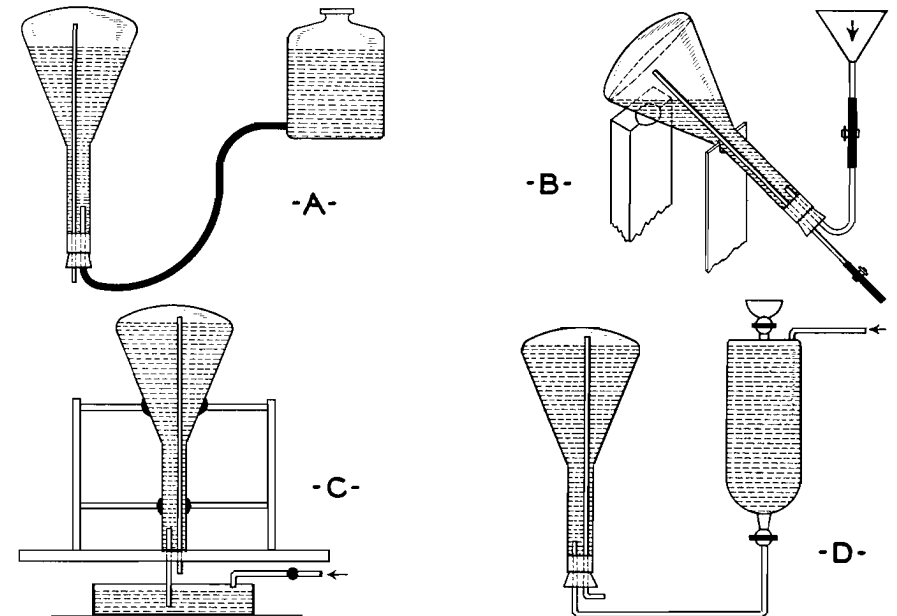

Fig. 3. Setups used in applying colloidal graphite dispersions. (3D, H. W. Weinhart, U. S. Patent No. 2096416.)

or potassium silicate binder, and second, by settling out of absolute alcohol and slowly decanting. The efficiency of such a screen varies between one and three candlepower per watt, depending on the particle size, screen thickness, anode voltage, willemite sat-

uration, and percentage of activator. Similarly, copper-activated zinc sulphide and zinc-cadmium sulphide, as prepared by the purification of the zinc salt and later fusing with a flux in a neutral atmosphere, is blown on the silicate-treated surfaces. Unlike the willemite, that can withstand maximum temperatures of $550^{\circ}C.$, the sulphide begins to oxidize at $450^{\circ}C.$ The screen efficiency is about the same for the two types, though the willemite saturates at a lower current density than the zinc sulphide.

Owing to the ability of the willemite to withstand the outgassing and annealing temperatures necessary to long tube life, it is widely used in this country, while European practices prefer the sulphide compounds for reasons not clearly known. However, the binding agents generally employed have not successfully justified themselves. In general, potassium silicate liquid and silicate of soda, the two most commonly used agents, are not of themselves fluorescent and hence prevent the impinging electrons from penetrating the binding layers enough to excite the fluorescent bodies to a maximum. Moreover, sodium silicate liberates sodium and discolors or burns under bombardment. Lacquer binders have been used with only moderate satisfaction. Boroglycerine, when used for its

Fig. 1. Hand-coating methods in cathode-ray production are disappearing.

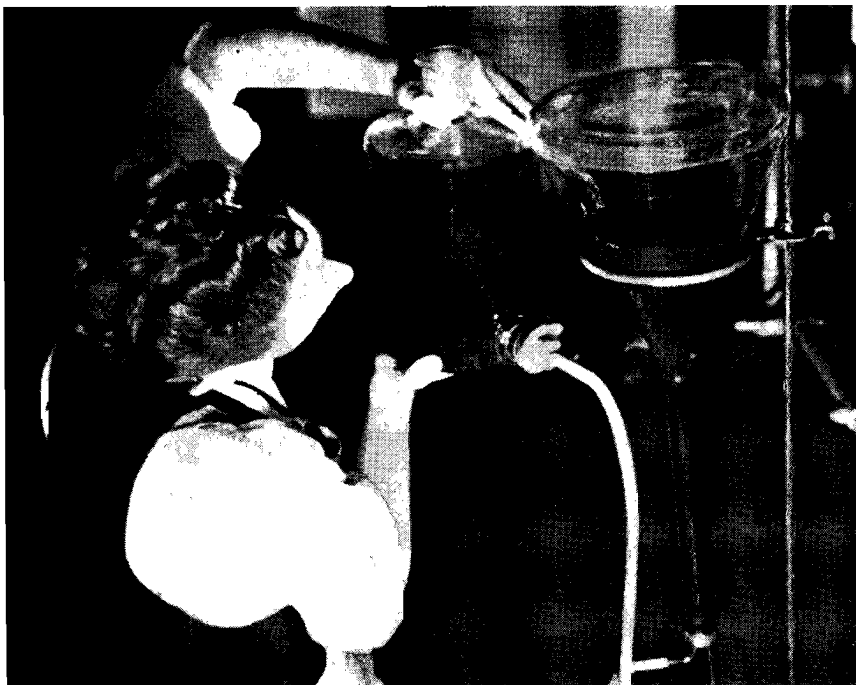



ability to combine with the glass in a binding sense, turns brown by tube heat and later disturbs the light emission.

The second method of application, namely, precipitation from alcohol, has the marked disadvantage of contaminating the light-sensitive phosphors with carbon compounds and impurities, thereby decreasing fluorescence. Also, such screens, unless sintered into glass, are sensitive to mechanical shocks, making shipments impractical. Carbon compounds, other than alcohol, as, for example, acetone, ethyl oxalate and glycerine, induce the formation of insulating films at the surface points of ray contact by the polymerization of the organic vapors emitted simultaneously. These layers, as formed on both the glass and metal tube parts, prevent the electron stream from hitting the fluorescent material itself.

A third procedure, frequently used, brings the glass near to its melting point and permits the fusing of the glass face with the fluorescent material. Particles, not firmly imbedded in the glass during the cooling of the envelope, are removed with a brush. Owing to the high heat conductivity of particles, the resulting frosted screen withstands stronger energy bombardment and provides more luminous intensity at the fluorescent spot than does a screen formed with potassium silicate binders.

Unfortunately, however, some degree of contamination of the luminescent powder results, and causes multiple reflections or halos that disrupt image definition. This effect is due to the total reflection of the fluorescent radiation at the glass-air interface of the glass wall.

Other considerations in television-tube production include the after-glow of the fluorescent compounds—a necessary attribute at one time for the prevention of flicker, though now not required as the effect is eliminated electrically; the sensitivity of the colors to heat in excess of 520° C. and the resulting formation of zinc silicate from the sulphide and soft glass; the non-injury¹ of the crystalline structure of the powder particles otherwise diminishing or destroying the fluorescence permanently; and finally, the absence of any traces of lead in or about the coating process that will contaminate or destroy the fluorescing properties of the sensitive phosphors.

Out of these difficulties, and perhaps in spite of them, the cathode-ray tube has come. A new binding agent of unknown chemical constituency, yet possessing the advantages needed, is ap-

¹Note: British Patent No. 471,190 (1937) suggests this can be overcome by treatment with an alkaline solution of ammonium hydroxide or ammonium carbonate.

plied by mechanical devices not unlike Fig. 2-A operating at a pressure of three atmospheres, and upon drying is covered with the filtered powders by means of the pump 2-B operating at $\frac{1}{2}$ - $\frac{3}{4}$ atmospheres. Frequently, the powders are merely stirred or agitated in air to produce a free-flowing and fluffy mixture that can be introduced in a hand-rotating tube to cover the face as desired.

NEW DEVELOPMENTS

Photometric measurements of the relative intensity of halos in sintered screens, with respect to total brightness of the luminescent radiation, reveals that one-fourth of the total light is dissipated. If the screen has a loosely-bound formation, the loss is only 1 to 4 percent. Obviously, a reduction in halo,

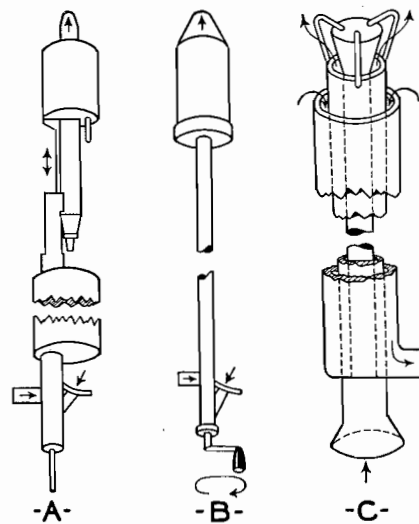

Fig. 2. Types of mechanical devices used in applying fluorescent powders.

so necessary for obtaining sharp oscillographic curves, requires either chemical binders of low absorption coefficient or no agent whatever. Working on the latter theory, research workers² have arranged a combination aspirator and gun (Fig. 2-C) which sprays sulphur dioxide and trioxide, carbon dioxide and monoxide, as the combustion products of burning carbon disulphide, onto the interior of the tube face, the later condensation of the gases resulting in a mosaic. After the application of the powders by the usual means, the sulphurous bodies are evaporated by heat, leaving the luminescent powders in intimate contact with the glass, and adhering by inter-molecular forces. The complete process³ has been thus described:

"The blank is filled with dense clouds from burning carbon disulphide. When the deposit is of a yellowish green

²H. W. Parker, U. S. Patent No. 2,094,242, (1937).

³W. H. Kohl, Canadian Journal of Research, 13, 129, (1935).

color, the blank is removed from the flame and allowed to cool. The deposit is then wiped from the wall of the blank with a cloth, except for the part that is to carry the screen. The fluorescent powder, which must be in a free flowing state, i. e., dry and of uniformly small particle size, is put into the blank and brought into contact with the sulphur coating by shaking it quickly with a circular motion. The sulphur coating picks up a uniform thickness of powder that is determined by the thickness of the original coating. The excess powder is removed by turning the blank upside down and shaking it violently. The wall is then wiped clean with a cloth and the edge of the screen reduced to the desired diameter. The sulphur deposit on the screen is driven off by holding the blank over a Bunsen flame of moderate temperature for a few minutes. This completes the process. A perfectly uniform screen adheres to the surface of the glass. The screen cannot be shaken off after exhaustion of the tube, but it can easily be removed with a cloth if another screen is to be put on. Blanks of medium size (3-inch screen diameter) can be coated in the same way. While exposing the blank to the vapor it is advisable to rotate it slowly in a holder, to ensure a uniform deposit of the vapor on the screen surface. The coating of such small blanks is carried out very easily in a very short time and at a minimum cost. The excess powder from the coating of one blank can immediately be used for the next one.

"Large-sized blanks for cathode-ray tubes of 5 inches or greater screen diameter require a specially designed double wall chimney that guides the vapor towards the screen surface, and prevents its condensation on the neck of the tube. This funnel ends in a specially designed mouthpiece which has a hollow glass cone with its apex pointing downwards, and which is supported in the inner tube. It serves to distribute the rising stream of vapor over a spherical angle and prevents it from hitting the center of the screen surface directly. The blank is rotated slowly during this stage of the process; after about 10 minutes a heavy deposit of sulphur is obtained. It was found useful, though not necessary, to cool the surface by means of water in a cylindrical container that fitted tightly over the face of the blank and rotated with it. After it has circulated within the bulb, the vapor is pumped off through the funnel by means of a water jet pump. This protects the operator from escaping sulphur vapors. The blank is then cleaned with a cloth, with which the sulphur deposit may be easily removed from the wall. In order to obtain a uniform

(Continued on page 36)

What **A.A.E.** means to you...

• Good condensers are usually taken for granted when dealing with a reputable manufacturer. But—how about getting the BEST condenser for that job? • That's where A. A. E.—**AEROVOX APPLICATION ENGINEERING**—comes in. • Our engineers work with you. They study your circuits, components, operating conditions, cost figures. • Result: Condenser satisfaction, maximum life, and usually, cost reduction. • Let's prove it to you!



AEROVOX CORPORATION

70 WASHINGTON STREET, BROOKLYN, N. Y.

Sales Offices in All Principal Cities



TELECOMMUNICATION

PANORAMA OF PROGRESS IN COMMUNICATIONS

SNOW STATIC DETECTOR

A SMALL DEVICE that detects and measures static is the latest development by United Air Lines' engineers in their drive on rain and snow electrical interference with plane-ground radio communication. The instrument is said to be so sensitive that it detects static not audible in the pilot's ear phones.

Designed to gauge the presence and volume of static electricity caused by electrically charged rain and snow particles, the new static meter was developed in the technical laboratory of United Air Lines. It locates static areas and measures their intensity to provide data useful in completing the elimination of this interference. Installation of two such devices has been made on United planes and production of a sufficient number to equip the entire fleet is being planned.

Pilots will report on static along with other weather conditions when they make their regular position reports at periodical intervals during flight.

SHIP-TO-SHORE RADIO-TELEPHONE SERVICE

SHIP-TO-SHORE radio-telephone service linking the ships of the U. S. Lines with any points in the Bell System has been inaugurated on the *Washington* and is now being made ready on the *Manhattan*

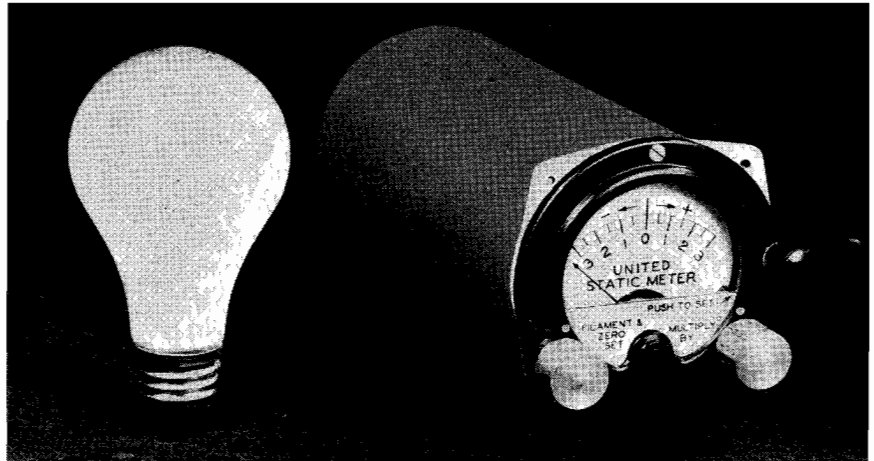

The snow and rain static detector compared in size with an ordinary light bulb.

by the Mackay Radio & Telegraph Company. These installations consist of Western Electric equipment designed especially for marine radio-telephone service and operate independently of the ships' radio-telegraph apparatus.

Calls between the vessels and either the United States or Europe may be made through these facilities during the entire trans-Atlantic voyage. The versatile transmitter used aboard ship is equipped with an automatic frequency-shifting mechanism. The twirl of a familiar telephone dial immediately transfers the radio transmitter to one of ten pre-selected radio-telephone chan-

nels. The equipment is especially designed to withstand a wide range of temperature and humidity conditions. A coaxial cable connects the radio transmitter with the antenna.

Since the radio receiver is designed so that watch may be kept simultaneously on three different shore-station frequencies, only one receiver is required aboard each ship for the radio-telephone service.

GOLD MEDAL FOR AIRCRAFT SAFETY EQUIPMENT

THE INTERNATIONAL JURY of the Paris World Exposition has awarded the Gold Medal for aircraft safety equipment and the Grand Prize for military and commercial airplane communication equipment to C. Lorenz-A. G., an associated manufacturing company of the International Telephone and Telegraph Corporation.

The safety equipment is the Lorenz Instrument Landing System for airports and aircraft which was demonstrated by the International Telephone and Telegraph Corporation in April and May at Indianapolis¹ for technical observers of the Army, Navy, the Federal Communications Commission and the Department of Commerce and the commercial airlines. It has been in use for a number of years at principal airports in England, Germany, Italy, Switzerland, Austria, Sweden, Poland, Japan

(Continued on page 38)



Chicago's fire chief is here shown demonstrating use of the new RCA 100-watt loud-speaker as installed on the cab of a light-generating truck used by the city fire department for all serious fires. His words, spoken into the microphone he holds in his hand, are heard over an area of several city blocks. The swivel which permits the speaker to be turned into any desired direction can be clearly seen.

¹See "Ultra-Short-Wave Radio Landing Beam," by R. Elsner and E. Kramar, p. 12, March, 1937, *Communication & Broadcast Engineering*. Also, "Lorenz Instrument-Landing System as Demonstrated at Indianapolis," p. 12, June, 1937, *Communication & Broadcast Engineering*.—Editor.

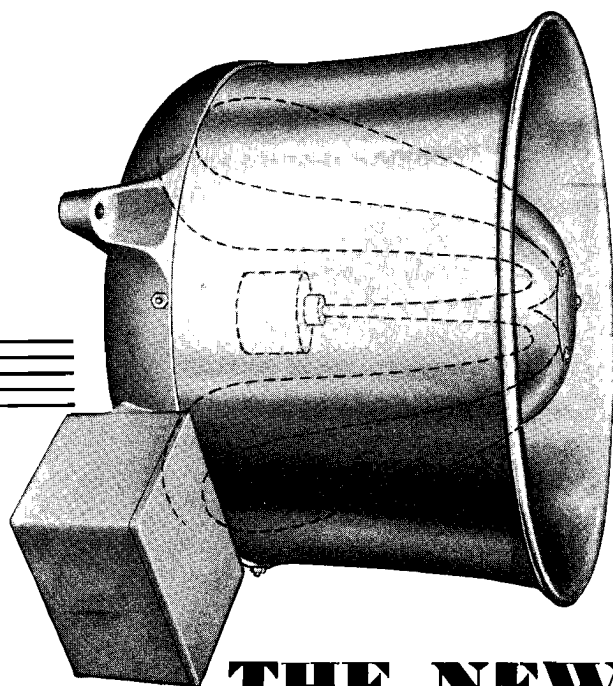

THE NEW BACON MARINE SPEAKER*

The following represent a few of the Steamships which are being equipped with RACON MARINE SPEAKERS on all embarkation decks:

United States Lines

S.S. "California"
S.S. "Pennsylvania"
S.S. "Virginia"
S.S. "Manhattan"
S.S. "Washington"
S.S. "Pres. Harding"
S.S. "Pres. Roosevelt"

Furness Steamship Lines

S.S. "Eastern Prince"
S.S. "Northern Prince"
S.S. "Southern Prince"
S.S. "Western Prince"

Munson Steamship Lines

S.S. "American Legion"
S.S. "Southern Cross"
S.S. "Pan American"
S.S. "Western World"
S.S. "Munargo"

Southern Pacific Lines

S.S. "Dixie"

Merchants & Miners Transp. Co.

S.S. "Alleghany"
S.S. "Berkshire"
S.S. "Chatham"
S.S. "Dorchester"
S.S. "Fairfax"

AGWI Steamship Lines

S.S. "Oriente"
S.S. "Coamo"
S.S. "Yucatan"
S.S. "Siboney"
S.S. "Borinquen"
S.S. "San Jacinto"
S.S. "Shawnee"
S.S. "Cherokee"
S.S. "Iroquois"
S.S. "Algonquin"
S.S. "Seminole"
S.S. "Orizaba"

Eastern Steamship Lines

S.S. "Acadia"
S.S. "St. John"
S.S. "Yarmouth"
S.S. "Evangeline"
S.S. "Robert E. Lee"
S.S. "George Washington"

Grace Steamship Lines

S.S. "Santa Barbara"
M.S. "Santa Clara"
S.S. "Santa Elena"
M.S. "Santa Inez"
S.S. "Santa Lucia"
S.S. "Santa Maria"
S.S. "Santa Marta"
S.S. "Santa Paula"
M.S. "Santa Rita"
S.S. "Santa Rosa"

Matson Steamship Lines

S.S. "Lurline"

Export Steamship Lines

S.S. "Excalibur"
S.S. "Excambion"
S.S. "Exeter"
S.S. "Exochorda"

Colombian Lines

S.S. "Haiti"

United Fruit Lines

S.S. "Antigua"
S.S. "Chiriqui"
S.S. "Petén"
S.S. "Oquirigua"
S.S. "Sixaola"
S.S. "Talamanca"
S.S. "Toloa"
S.S. "Ulúa"
S.S. "Veragua"

Savannah Lines

S.S. "City of Birmingham"
S.S. "City of Chattanooga"

*Used in all Emergency Loudspeaker Systems approved by the Bureau of Marine Inspection and Navigation Department of Commerce for ship use, under the 53rd Supplement of the Bureau, after tests made by the Bureau of Standards.

The latest speaker in Marine Practice. A compact re-entrant type of horn, 14" in diameter, 10" deep, having a base of heavy aluminum casting and heavy aluminum spinning. Uses a Driving Unit of the latest type made of Alnico Steel and Armco Iron, resulting in the most efficient unit of its size ever developed. The Driving Unit and connections are all enclosed making a completely waterproof speaker, not affected by temperature or weather, including use on sea even during storms.

Used as a LOUDSPEAKER and as a MICROPHONE, will pick up sound outdoors from distances up to 100 feet with very small amplifying gain, and will deliver 100 db. of sound 10 feet from the horn with an input of one watt.

Makes an ideal speaker not only for Marine work, but also for general PA use as well, where highly concentrated sound for great distances is required.

Technical Data and Prices on Request

WEIGHT 25 POUNDS — Code REDIM

224 Fourth Avenue, New York City

RACON ELECTRIC CO. INC.

OVER THE TAPE . . .

NEWS OF THE COMMUNICATIONS FIELD

WESTINGHOUSE MOVES RADIO DIVISION

The Radio Division of the Westinghouse Electric and Manufacturing Company will be moved to Baltimore, Md., from the present location at Chicopee Falls, Mass., according to Walter C. Evans, Manager, Radio Division.

The company has purchased a modern manufacturing plant at Wilkins Avenue and Catherine Street, on the main highway to Washington, approximately four miles from the center of the Baltimore business district. Plans have been made for the erection of a modern office building adjacent. Construction work will be begun at once, and it is expected that the transfer of the employees and their families, together with equipment, will be completed within the next six months.

VOLUME CONTROL REPLACEMENT LISTING

This volume control replacement listing indicates at a glance the makes and types of sets served, as well as the function and list price of some twelve hundred exact-duplicate controls numerically listed. The numerical listing is in the form of a 9-page bulletin, a copy of which may be had by addressing Clarostat Mfg. Co., Inc., 285-7 North Sixth St., Brooklyn, N. Y.

J. F. CUNNINGHAM RECEIVES APPOINTMENT

John F. Cunningham, Supervisor of Production for the General Electric Company since September, 1931, has been appointed Assistant to the Vice-President in charge of manufacturing, succeeding Myron F. Simmons, who has retired. The announcement was made by W. R. Burrows, Vice-President in charge of manufacturing. The appointment was effective January 1, 1938.

WESTON BULLETIN

"Weston Test Equipment For Industry, School and Laboratory," a new bulletin describing multi-range test equipment of high flexibility, has just been issued by the Weston Electrical Instrument Corporation, Newark, N. J. This bulletin illustrates six standard models of the multi-range test instruments, and contains complete description of their uses, ranges, electrical specifications, dimensions and prices.

JETT APPOINTED CHIEF ENGINEER OF FCC

The Federal Communications Commission have appointed Lieutenant Ewell K. Jett, its chief engineer. Lieutenant Jett succeeds Commander T. A. M. Craven who was appointed Commissioner on August 23, 1937.

LEEDS & NORTHRUP CATALOG

A new catalog on "Deflection Potentiometers and Accessories" will be of interest to laboratories in which large numbers of d-c deflection instruments are calibrated or checked, or where lamp-efficiency tests are made. To receive a copy, ask Leeds & Northrup Company, 4934 Stenton Avenue, Philadelphia, Pa., for Catalog E-50B(2).

MALCOLM FERRIS DIES

Malcolm Ferris, President and founder of the Ferris Instrument Corporation, passed away on December 23, 1937. Mr. Ferris, who had not recovered from an operation performed several weeks earlier, was forty-three years old.

The Board of Directors of the Ferris Instrument Corporation have decided to continue, unchanged in any important respect, the business and policies which Mr. Ferris began. Mr. J. H. Redington will be Treasurer and Sales Manager of the Company, and C. J. Franks President and Chief Engineer.

AMPERITE BULLETIN

Amperite Company, 561 Broadway, New York City, have just issued a new bulletin describing and giving specifications of their line of microphones, microphone stands, etc. Of special interest is the Amperite velocity microphone equipped with the "acoustic compensator." This bulletin may be secured by writing to the above organization.

SYLVANIA CHARACTERISTIC SHEET

Hygrade Sylvania Corporation announces a revised edition of the popular Sylvania Tube Characteristic Sheet, containing characteristic data on all tube types now available in the Sylvania line. Data on fifteen new types, and four new base views have been added. Data on older types have been revised to bring the characteristics up to date.

The sheet is printed on heavy stock, and is folded and punched for use in standard three ring binders. It can also be opened to full size for use as a wall chart. It is supplied free on request through jobbers handling Sylvania tubes.

RCA BULLETINS

A number of new bulletins have recently been issued by the RCA Manufacturing Co., Inc., Camden, N. J. The bulletins cover the following equipments: the Model AVT-7B 20-watt 4-frequency aircraft transmitter; the AVR-7D, -7E, -7F, and -7G aircraft radio receivers; the 82-A monitor amplifier, a flexible 8-watt high-fidelity a-c operated unit; the Type OP-5 remote pickup equipment; and the Type 96-A limiting amplifier. These bulletins may be secured from the above organization.

JENSEN AND CANADA WIRE COMPLETE DEAL

To facilitate service to Canadian radio set manufacturers, Jensen Radio Manufacturing Company has recently concluded arrangements with Canada Wire and Cable Company of Toronto, Ontario, for the manufacture of Jensen engineered products in Canada. Under the supervision of Mr. K. M. Clipsham, Jensen speakers will be manufactured and shipped by Canada Wire and Cable Company. The new Jensen Sales Office, Mr. C. A. Savage in charge, is to be located at 45 Richmond Street, West, Toronto.

RCA—HAZELTINE AGREEMENT

Radio Corporation of America announced recently that it has entered into agreements with Hazeltine Corporation whereby it has acquired simple non-exclusive licenses in all radio fields under the Hazeltine patents. These agreements effect termination of long pending litigation between the parties.

AMERICAN NATIONS IN RADIO TREATY

A treaty of North American nations for operation and regulation of radio broadcasting will develop from the Inter-American Radio Conference just concluded at Havana. Eventually, within a few years, there will result changes in frequencies of many American stations. The U. S. delegation at the Havana Conference was headed by Commissioner T. A. M. Craven of the Federal Communications Commission, and the first radio treaty, it is expected, will be signed by this country, Canada, Mexico, Cuba, Santo Domingo, and Haiti.

"Dual" stations in Mexico, which have interfered with broadcast reception in the United States, will be eliminated, and short wave, police, and aviation services broadened.

RCAI GROWING

The student body at RCA Institutes, Inc., RCA's school for operators and radio engineers, has been steadily growing for the past few years, and reached a height of 905 in 1937, about two-thirds of these being in the New York school and the remainder in Chicago. To these must be added 25 RCA employees who are receiving free instruction in the schools.

MANY JOINS KENYON

The appointment of W. G. (Bill) Many as Sales and Advertising Manager of the Kenyon Transformer Company, Inc., 840 Barry St., New York City, has just been announced. The present appointment is in line with the desire of the Kenyon organization to keep in close touch with its jobbers and to aid them in serving their trade in the transformer and amplifier fields.

VOLUME-CONTROL GUIDE

Centralab, 900 E. Keefe Ave., Milwaukee, Wisconsin, have just issued a supplement to the 1937 edition of their volume-control guide. A complete line of standard midrange replacements and universal auto replacements are listed. To secure a copy of this bulletin write to the above organization.

PURINTON IN CHARGE OF RAYTHEON'S NEW YORK OFFICE

On January 1, Raytheon Manufacturing Company, 190 Willow Street, Waltham, Massachusetts, announced the opening of their New York office in charge of R. M. Purinton, District Sales Engineer. The New York office is located at 420 Lexington Avenue, the telephone is Mohawk 4-1341.

Let CLAROSTAT

Solve

YOUR RESISTANCE PROBLEM

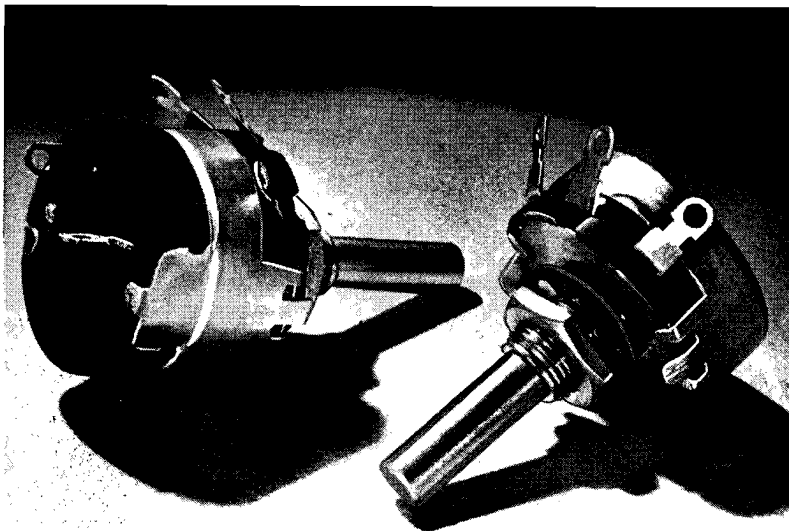

- Series M CLAROSTAT Midget Controls with and without power switch. Composition element. Widest choice of resistance values. All standard tapers.

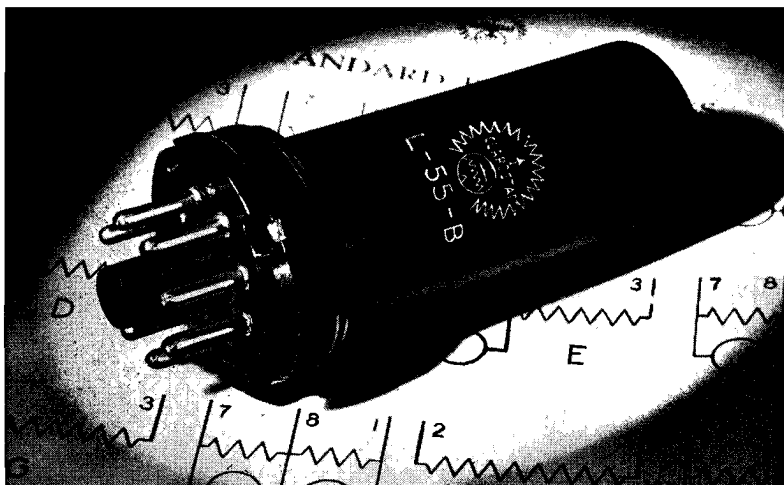

- Series MT CLAROSTAT Metal-Tube Resistors for voltage-dropping and voltage-dividing functions. Widest choice of resistance values, taps, pilot-light provisions, etc. Octal and UX bases.

CROWDED for space? . . . Well, here are two quite helpful aids in designing exceptionally compact assemblies. These are (1) CLAROSTAT Midget Controls, and (2) CLAROSTAT Metal-Tube Resistors. Their use in almost countless radio sets, amplifiers and other assemblies has already established a new standard of performance.

Series M CLAROSTAT Midget Controls have been designed from scratch by our engineers during the past several years. This is a NEW control. It isn't only smaller: it incorporates an entirely NEW resistance element, a NEW mechanical design, and a NEW choice of alloys. We invite the most rigid tests and comparisons.

Then there's the Metal-Tube Resistor, developed, introduced and pioneered by CLAROSTAT. Hundreds of thousands are in daily use for voltage-dropping and voltage-dividing functions. We invite you to check their service records.

Get Your Copy

Loose-leaf engineering data covers all types of resistors and resistance devices. Ask for your copy. And submit that resistance problem.

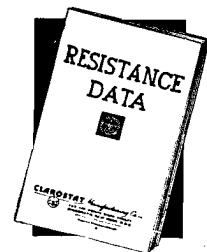

CLAROSTAT *Manufacturing Co. Inc.*



285-287 NORTH SIXTH STREET
BROOKLYN, NEW YORK, U.S.A.

• OFFICES IN PRINCIPAL CITIES •

12Y REMOTE AMPLIFIER



The 12Y is the smallest and most compact single channel amplifier. It more than meets every exaction which can be placed upon it by modern broadcasting.

COLLINS RADIO COMPANY

CEDAR RAPIDS IOWA
NEW YORK, N. Y.: 11 WEST 42 STREET

RMA EASTERN CREDIT COMMITTEE MEETING

There was a large attendance at the regular monthly meeting of the RMA eastern credit committee at the Hotel New Yorker in New York City on December 16, under the chairmanship of Vice-Chairman Victor Mucher and with the cooperation of the National Credit Office, the official credit information agency of RMA. It is desired that RMA members again be advised of their privilege to secure detailed credit data, submitted at the committee meetings, by writing to the National Credit Office, 2 Park Avenue, New York City.

PHILCO AUTO-RADIO LABS. IN DETROIT

Philco Radio and Television Corporation announced recently the removal of its automobile-radio engineering laboratories from Philadelphia to Detroit. The move was made, according to officials of the company, to place its trained research engineering staff in close proximity to the motor vehicle plants in and about Detroit. These trained technical men will now be in direct contact with the engineering staffs developing and producing motor vehicles.

SENATOR WHITE CHAIRMAN OF U. S. DELEGATES TO CAIRO

Senator Wallace H. White, of Maine, will be chairman of the U. S. Delegation to the International Radio Conference at Cairo, Egypt, next February. Other delegates will be Admiral Hooper of the Navy Department, E. K. Jett, chief engineer of the Federal Communications Commission, and Francis C. de Wolf of the State Department Treaty Division.

S.S. WHITE BULLETINS

The Industrial Division of the S. S. White Dental Manufacturing Co., 10 East 40th St., New York City, have made available two new bulletins. Bulletin No. 1137 refers particularly to flexible shafts and casings for auto radios and gives specifications for various types of swaged ends which can be supplied on the shafts. The other bulletin gives further information on flexible coupling shafts and contains two illustrations of actual applications.

"TUBE" TO BE DEFINED

Progress is being made by RMA toward promulgation of an industry definition of a "tube." An official definition has been recommended to the RMA Tube Division by the Association's engineering branch, and the tube manufacturers will meet early in January to take action and make final recommendations to the RMA Board of Directors. Other important business is scheduled for the January meeting of the Tube Division, now being arranged by Chairman B. G. Erskine of Emporium, Penna.

GOVERNMENT GIVES FURTHER RECOGNITION TO RADIO

RMA members are being forwarded a current copy, under a new title, of "Electrical and Radio World Trade News" of the Department of Commerce. In further government recognition of the radio industry, the new name for the government publication has been accorded. Its former title was "Electrical Foreign Trade Notes," and the new name is given in response to frequent RMA requests for greater specific recognition of the radio industry now adopted through John H. Payne, chief of the Electrical Division.

Waxes Compounds Varnishes

FOR INSULATION
OF CONDENSERS

Transformers, coils, power packs, pot heads, sockets, wiring devices, wet and dry batteries, etc. Also WAX SATURATORS for braided wire and tape. WAXES for radio parts. Compounds made to your own specifications if you prefer.

● ZOPHAR MILLS, INC.

Founded 1846
120—26th Street
Brooklyn, N. Y.

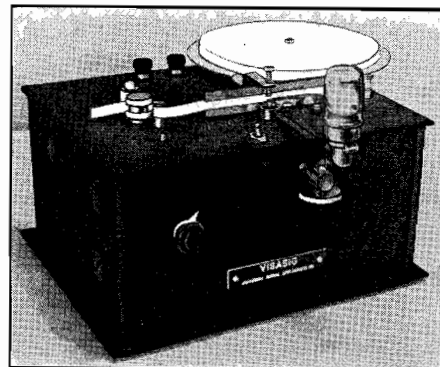

VISASIG full automatic Radio Telegraph Recorder

FOR COMMERCIAL AND AMATEUR USE

1 cent's worth of tape records over 3,000 words

Model VI-B—Semi-Professional

List \$75.00

Model V-5—Professional High Speed

List \$175.00

Prices FOB New York City

Write for Full Particulars

UNIVERSAL SIGNAL APPLIANCES

Department C

64 West 22nd Street New York City

Export Department:

116 Broad St., N. Y. C., U. S. A.

Cable Address: Auriema, N. Y.

DR. MARVIN L. FAIR RECEIVES APPOINTMENT

Announcement was made by Commissioner Thad H. Brown, who has been designated by the Commission to have charge of the Great Lakes and Inland Waters Survey, of the appointment by the Commission of Dr. Marvin L. Fair as Research Director for the Survey.

Commissioner Brown said that Dr. Fair would take active charge as Research Director on February 1, when he would take a leave of absence from his position as Professor of Transportation and Public Utilities at Temple University, Philadelphia, Pennsylvania. He will devote part time to the work until that time. Commissioner Brown stated that Dr. Fair would work in association with Dr. G. Lloyd Wilson, who was appointed on December 17 as Research Consultant for the Survey.

HAMMARLUND CATALOG

The Hammarlund Manufacturing Company, Inc., 424-438 West 33 Street, New York City, have just issued their "38" Catalog. This attractive catalog covers the Hammarlund line of midget condensers, transmitting condensers, coils, coil-forms, sockets, r-f chokes, i-f transformers, and receiving equipment. This catalog may be secured by writing to the above organization.

CORNISH WIRE ENLARGES FACILITIES

In the accompanying illustration is shown one of the drawing machines in the equipment of Cornish Wire Co., Inc., with

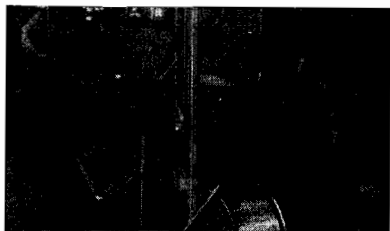

factory at Paterson, N. J., and office at 30 Church Street, New York City.

Corwico radio, hook-up and public-address wires are made from the ground up in one large, modern plant.

Complete literature relative to the many types of wire made by Cornish may be had on request.

HYDRAULIC PRESS BULLETIN

"Hydro-Power Presses for the Process Industry" is the title of an 8-page bulletin recently issued by The Hydraulic Press Mfg. Co., Mount Gilead, Ohio. Complete descriptions of the HPM line of presses are given. Write to the above organization for Bulletin No. 3706.

"MACHINING ALUMINUM"

"Machining Aluminum" is the title of a 32-page booklet just issued by the Aluminum Company of America. It may be secured from any of the organization's sales offices which are located in all principal cities. Some 19 pages in this booklet have been devoted to general machining practice, while approximately 10 pages are given over to automatic screw-machine practice. A number of tables, covering approximate feeds, physical properties, mechanical properties, weights, tolerances, etc., are also included.

FOR RECORDING STUDIOS THAT CAN AFFORD THE BEST

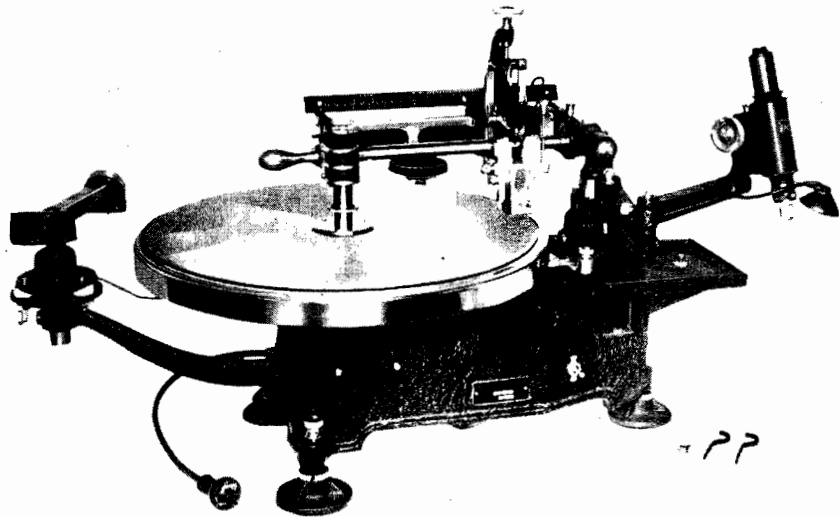

THE PRESTO STATIONARY RECORDER

Experienced recording engineers, those who are expected to get results *every time*, appreciate the refinements, the extra factors of safety and convenience, included in this Presto recording turntable.

Now that you know that instantaneous recording is a profitable fast growing business—give your engineer the best in equipment and be certain of producing the kind of records that keep your studios busy and make money for you.

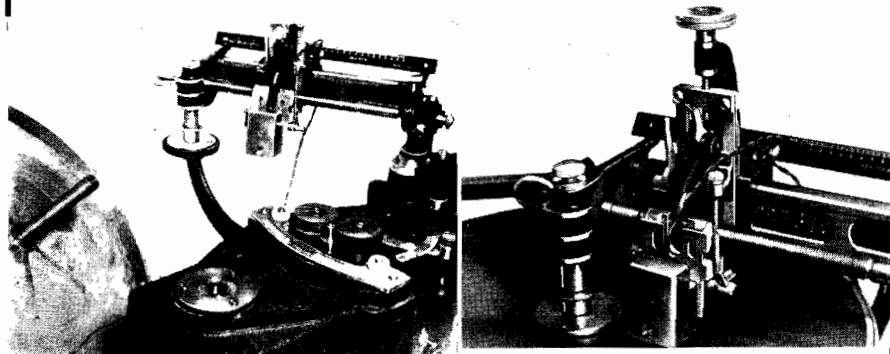

A heavy duty, constant speed motor drives a perfectly balanced cast iron turntable at the rim—the point of greatest leverage — providing ample power for recording and assuring absolutely steady speed. You can change speed from 78 to 33 $\frac{1}{2}$ RPM in less than 2 seconds.

Note the cam levers for lowering the cutting head and engaging the feed screw, the heavy guide bar for the cutter carriage, the scale indicating elapsed recording time, the quick adjustments of the cutting needle angle and pressure.

Send for the Presto catalog giving full technical description.

PRESTO RECORDING CORPORATION

145 W. 19th ST., NEW YORK

CUTLER-HAMMER SALES OFFICE

To better serve their many customers in the Northwest, Cutler-Hammer, Inc., Milwaukee, manufacturers of electrical apparatus, have opened a branch sales office in Portland, Oregon, with Mr. F. J. Woldrich in charge. Located at 625 N. W. Everett Street, the Portland office will operate under the supervision of the company's Seattle office.

I. T. & T. APPOINTMENT

Mr. Ellery W. Stone, who is in charge of the radio telephone and radio telegraph operations of the International Telephone and Telegraph Corporation and its subsidiaries, has been elected a vice-president of All America Cables, Inc., and will be in active charge of the radio activities of that company throughout its system, as well as of the radio communication activities of the other I. T. & T. subsidiaries. All America Cables during the last seven years has constantly expanded its radio operations by establishing stations in Central and South America. All America Cables, together with other I. T. & T. subsidiaries, operate radio stations in Peru, Colombia, Nicaragua, Argentina, Brazil, Chile, Cuba and Puerto Rico. These stations furnish radio telephone and radio telegraph services with the United States and various other countries throughout the world.

UNIVERSAL MICROPHONE ANNOUNCES PRICE REDUCTION

The Universal Microphone Co., Inglewood, Cal., has announced a price reduction in the list price of its crystal microphones. All crystal models of the Universal Microphone Co. are manufactured under patents of the Brush Development Co.

TRADE TREATY WITH GREAT BRITAIN

The RMA will represent industry interests in State Department negotiation of the proposed reciprocal trade treaty with the United Kingdom and also in revision of the Canadian trade pact. Anticipating the trade treaty negotiations with Great Britain, the RMA Board of Directors already has considered some of the major problems involved and has made informal recommendations regarding radio policies to government officials. The treaty negotiations are expected to extend over several months, and the RMA Export Committee, of which S. T. Thompson of Long Island City is Chairman, will compile and present to the State Department detailed recommendations and data affecting radio interests.

NEW FACTORY FOR DUMONT

Crowded out of its present quarters in Upper Montclair by the rising volume of business and the indications of expanding applications, the Allen B. DuMont Labs., Inc., will move shortly after the new year to their own factory building at 2 Main Ave., Passaic, N. J.

The attractive two-story-and-basement building of concrete and steel construction was recently purchased by the DuMont organization. It contains more than 22,000 feet of floor space, and there is ample land for expansion. The DuMont personnel will be at least doubled when the company moves into its new quarters. In addition to the present production of cathode-ray tubes and oscillographs, the company is developing television equipment and preparing for the mass production of necessary tubes and equipment when and as commercialized television makes its debut.

EXCISE TAX RULING ON POWER ADAPTERS

Power adapters, such as those with 2-volt battery sets, permitting such sets to be operated direct on 6-volt storage batteries, are not "power packs" within the meaning of the federal excise tax law and are not subject to the excise tax when sold separately, according to an informal ruling secured by RMA from Internal Revenue Bureau headquarters. When such power adapters are sold by a manufacturer direct to distributors, they are not subject to the excise tax. However, if the power adapters are incorporated in the chassis of a receiving set, the entire chassis assembly is taxable under the general rulings in the past covering inclusion of untaxable components in a complete chassis.

NEW CROSLEY OFFICIAL

James D. Shouse, former general manager of KMOX, St. Louis, has been appointed vice-president of the Crosley Radio Corporation in charge of broadcasting. Powel Crosley, Jr., president, announced recently. Mr. Shouse has been associated with the Columbia Broadcasting organization for more than nine years.

RADIO PARTS TAXABLE IN INTER-COMMUNICATING DEVICES

Loudspeaker and amplifier manufacturers, as well as all makers of intercommunicating office devices, will be interested in an informal ruling secured by RMA from Internal Revenue Bureau that certain radio components of such devices are taxable. Even though a manufacturer is a specialist in such office units, is not in the radio industry and does not manufacture radio sets, the taxable radio components of such intercommunicating devices are subject to the 5 percent radio excise tax.

The questions involved recently were submitted by several RMA members to association headquarters and taken up with Internal Revenue Bureau officials. The informal ruling of the Government is that if the radio components of intercommunicating office devices are capable of being used in receiving sets—"suitable for use" and used in receiving set manufacture—the 5 percent radio tax must be paid thereon by the manufacturer.

Loudspeakers, which are "suitable for use" and used in receiving sets, although actually incorporated in intercommunicating devices, are subject to the radio tax. Transformers and condensers are not subject to taxation when sold separately. However, if a transformer is combined and mounted with a radio speaker, forming a complete speaker, the entire assembly is subject to the radio tax.

If the cabinets of intercommunicating devices are specially designed and not "suitable for use" or actually used for receiving sets, they are exempt from taxation unless they have been used or are also used in assembly of radio sets.

"Suitability" of a product for radio usage is the general taxation test affecting taxable components. The Internal Revenue Bureau's ruling on "suitability" for use, made in August, 1932, and not since modified, follows:

"As to the interpretation to be placed on the phrase 'suitable for,' where it is found that any of the articles enumerated in section 607 of the Act have been or are being used in radio receiving sets or combination radio and phonograph sets, they are considered as 'suitable for' use in connection with or as a part of such sets and are taxable."

ZIERICK CATALOG

Catalog No. 14 is available from the Zierick Manufacturing Corp., 385 Gerard Avenue, New York, N. Y. This catalog covers the Zierick line of radio terminals, automotive cable terminals, eyelet terminals, screen-grid caps, fuse caps, battery clips, light sockets, wire forms, etc. To secure a copy of this catalog write direct to the above organization.

U. S. RUBBER PRODUCTS APPOINTMENTS

The Mechanical Goods Division of United States Rubber Products, Inc., has announced that Frederick D. Benz, formerly manager, Wire Sales, Chicago Branch, United States Rubber Products, Inc., has been appointed district manager of Wire Sales, Pacific Division, for the same company, with headquarters at San Francisco. This division comprises the Los Angeles, San Francisco, Portland, Seattle, Spokane and Salt Lake City territories.

RADIO RECEPTION STUDIES

Interference problems in radio reception were considered at another meeting of the Joint Coordination Committee of Edison Electric Institute, National Electrical Manufacturers Association and RMA at a meeting October 29 in New York City. Reports were made on measures to reduce radio interference from power lines, antennas, electrical apparatus of various kinds, small motors, and receiving sets. The committee also considered proposed data for radio service men in reducing interference and other industrial cooperation having the same objective.

TRIPLETT BULLETINS

Triplet has recently issued bulletins covering their illuminated dials, laboratory test bench panels, and the Model 1504 tube tester. To secure these bulletins write to the Triplet Electrical Instrument Co., Bluffton, Ohio.

NEW RMA SERVICE PROVIDED FOR AMPLIFIER MANUFACTURERS

A new engineering and merchandising service for RMA companies manufacturing amplifiers, requested by the Association's Amplifier and Sound Equipment Division, was approved by the Association's Board of Directors at its Chicago meeting on November 17. Chairman Peter L. Jensen of the Division presided and the RMA Board authorized a plan to promote the interests and sales of amplifier companies who are members of the Association by their use of an official RMA seal on their products certifying to definite RMA engineering standards.

A substantial appropriation to institute service for the RMA amplifier makers was voted by the Board of Directors and a special committee, consisting of Directors A. S. Wells and J. J. Kahn of Chicago, and Roy Burlew of Owensboro, Ky., was appointed to cooperate with Chairman Jensen of the Division and President Muter of RMA in organizing the entire amplifier project. The Association's Standards Committee will promulgate amplifier standards. Testing facilities will be arranged by RMA and upon conformance with the engineering requirements, amplifier manufacturers who are members of the Association will be permitted to use the official RMA seal in the merchandising of their amplifiers. Similar use of an official RMA seal by set manufacturers was adopted several years ago, and several million RMA seals have become familiar insignia on radio sets in national sales channels.

THE MUSA

(Continued from page 22)

will be out of phase, and their vector sum will thus be less than when they are in phase. As a result a directional characteristic is obtained, and—other things being equal—the characteristic will be sharper the greater the number of antennas in the array. If with such an antenna array some provision is made for changing the phase-shifting networks in unison, so that when that for antenna 2 is changed from ϕ to $(\phi + \Delta)$, that for antenna 3 will be changed to $2(\phi + \Delta)$ and that for antenna 4 to $3(\phi + \Delta)$ and so on, then the angle of most effective reception can be changed merely by changing the values of the ϕ 's.

The experimental musa now set up at Holmdel consists of six rhombic antennas, and gives a sharp receiving characteristic as indicated in Fig. 3. Besides the main lobe there are several minor ones on each side, but the magnitude of these is comparatively small. There will also be other main lobes, but by the design of the array and the individual antennas these are made to fall outside of the range over which the musa is designed to act. The direction of the main usable lobe may be made to vary over the steering range depending on the value of ϕ , and the steering range, in turn, will be larger or smaller depending on the design of the individual antennas and on the distance between the centers of the antennas.

As already pointed out, there may be prominent signals arriving in several directions at the same time, and to obtain the maximum receiving advantage all these signals should be separately received and suitably combined at the receiver. The musa readily permits this to be done by providing a number of parallel circuits connected to the same antenna but each having a separate set of phase-shifting networks. Each of these branch circuits with its phase-shifting networks becomes in effect an independent musa, and each may be set to receive at a different angle. Since the length of path, as is evident from Fig. 1, is different for each direction of arrival, the transmission delays of the various paths must be equalized, which is readily accomplished by delay networks in the branch paths.

In the experimental musa at Holmdel, three such branch paths are provided as indicated in Fig. 4. The three branch circuits are formed at the output of the first detectors for the six antennas of the array, and the three sets of phase shifters in the branch circuits are separately controlled by three dials. One of the branches, shown at the right

(Continued on page 36)

Jensen PERI-DYNAMIC REPRODUCERS

... with *Bass Reflex*

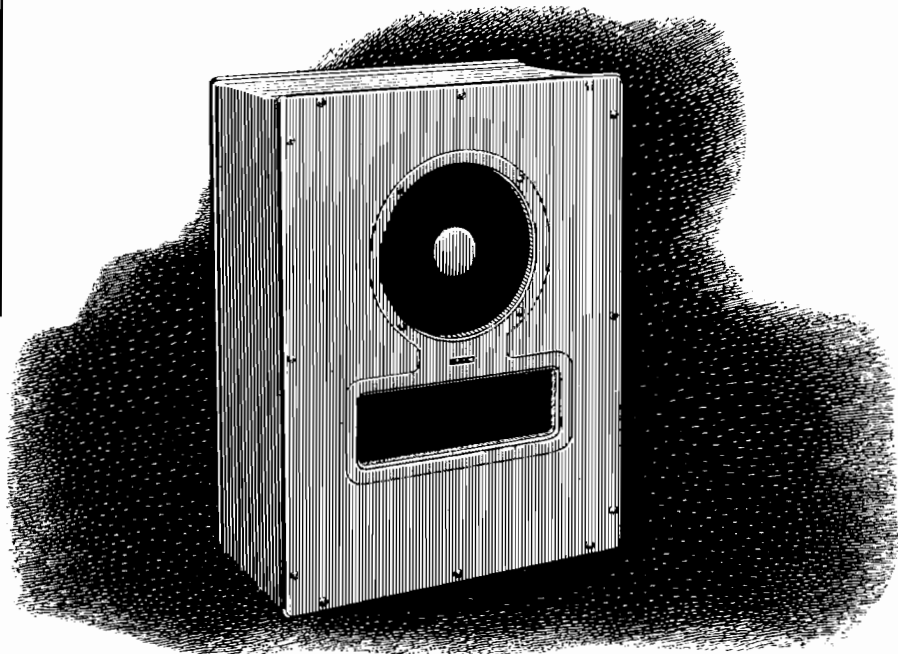

NOW OFFERED WITH **Jensen Auditorium and 18" Speakers**

The outstanding performance of these "Standard of the World" speakers is now improved by the advanced acoustic principles, incorporated in these new reproducers, which add new octaves of low frequency response and exceed in ability even an infinite baffle.

AND as separate enclosures correctly designed for the thousands of these speakers already in use and inefficiently "baffled."

Enclosures are shipped in knock-down kit form for convenience and low cost. Those who know the performance improvement, convenience and low cost of Jensen *Peri-dynamic* Reproducers for 8, 10, 12 and 15-inch speakers will cheer the addition of these new models. Write for new descriptive literature describing the complete line of Jensen *Peri-dynamic* Reproducers.



JENSEN RADIO MFG. COMPANY C-138
6601 S. Laramie Avenue, Chicago, Ill.

Please send me new literature describing Jensen *Peri-dynamic* Reproducers for Auditorium and 18" Speakers.

Name

Address

City State

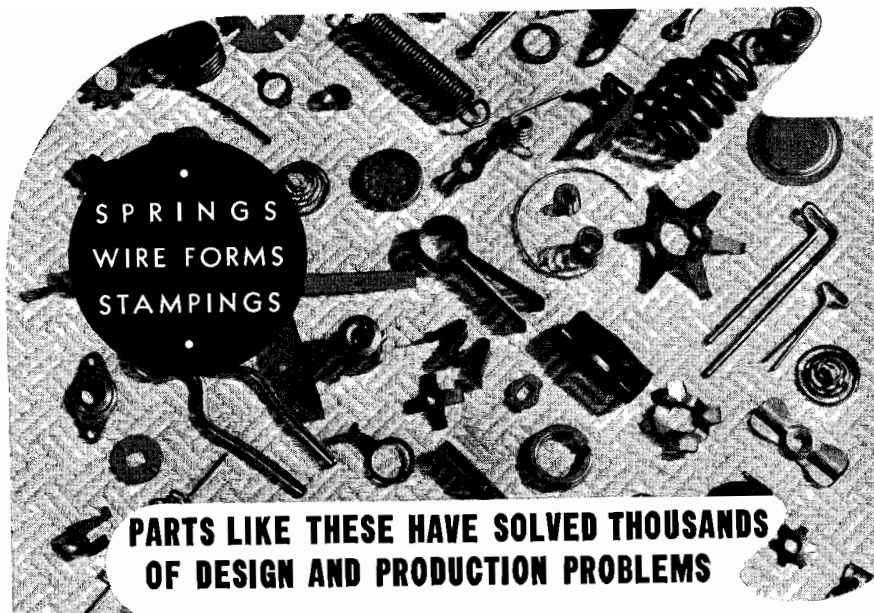

PARTS LIKE THESE HAVE SOLVED THOUSANDS OF DESIGN AND PRODUCTION PROBLEMS

Every piece illustrated represents a design or production problem solved—many highly involved. Hubbard has made thousands of parts like these, in all kinds of shapes and materials.

Hubbard's long experience, skill, extensive facilities, and modern equipment can work out the right part essential to your design or production scheme.

It will pay you to inquire.

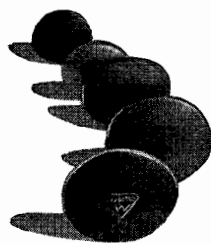

Hubbard Expansion Plugs "The Original Welch Plug"

M. D. HUBBARD, Pres. P. M. HUBBARD J. A. HUBBARD, Secy.
M. D. Hubbard Spring Company
 672 CENTRAL AVE., PONTIAC, MICH.

UNIVERSAL'S Complete Instantaneous School and College Recorder



... for speech, language, dramatic and music departments. Play back immediately on same machine or file for future. Simple to operate. Results guaranteed.

Recording Division

UNIVERSAL MICROPHONE CO., LTD.
 BOX 299, INGLEWOOD CALIFORNIA, U. S. A.

ERPI LABORATORY

ELECTRICAL RESEARCH PRODUCTS INC., a subsidiary of the Western Electric Company, whose activity is devoted to the commercialization of products of the latter company not primarily intended for use in the telephone industry, has formally opened its New York engineering laboratory. The new institution is a modernized version of the former, but less conveniently located laboratory in the Bronx.

Occupying more than ten thousand square feet, divided between two floors,

the new plant includes laboratories for the investigation of problems in optics, speech transmission, sound recording and sound reproduction, acoustical problems, a theatrical review room, a model shop, machine shop, an acoustic dead chamber, general offices and service departments.

Among the numerous recent ERPI developments are included a 16-mm sound-film recorder which is said to incorporate all the detailed engineering and careful planning which the professional 35-mm machines represent.

THE MUSA

(Continued from page 35)

in Fig. 4, is used only to explore the angle range to determine the angles at which waves are arriving. Its output is connected to a cathode-ray oscilloscope which shows amplitude as the ordinate with phase shift as the abscissa. The plot in the illustration indicates strong signals at two values of ϕ .

The other two branches pass through separate branch receivers, and then one is passed through an adjustable delay network to equalize the transmission delays before the two outputs are combined. The correct delay is indicated by a second oscilloscope as indicated in the illustration. When the delays are properly equalized the oscilloscope will show only a diagonal line, or compact elongated figure, as indicated. In this way, the musa may be held at all times on the two most prominent incoming signals, and the sharp directivity of the individual lobes insure the high ratio of signal-to-noise that is desired.

PRODUCTION DEVELOPMENT OF TELEVISION TUBES

(Continued from page 26)

screen, the powder should be whirled into a cloud before it makes contact with the surface. If the powder makes its first contact with the screen in a mass, streaks are liable to be left, but after the original contact the powder is allowed to slide over the surface in bulk."

Finally, the grounding of the phosphors for the dissipation of accumulative electron charges has been accomplished in oscillographic tubes by a path of colloidal graphite across the tube face and connecting with the side-wall anode. This film is formed before the fluorescent powders are applied. An improved procedure⁴ for shielding the screens of television tubes consists of first settling minute metal particles and then coarser fluorescent bodies from the same solution.

WALL ANODES

Among the factors of screen curvature, halation, and stray electrons from cold and secondary emission of tube parts, as contributing to maximum image contrast or lack thereof, production departments have been long concerned over light reflection within the tube. The glass envelope alone reflects about 10 percent of the light falling on it, while the second or focusing anode may reflect considerably more. Reflected radiation penetrating the translucent screen is also disturbing.

The relation of these effects to the necessity of providing a conductive anode on the interior glass walls, and

⁴J. C. Batchelor. U. S. Patent No. 2,062,858 (1936).

the attendant production techniques for overcoming them, have been discussed elsewhere.⁵ Briefly, the conducting and non-reflective features have been provided automatically in the earlier gas-filled tubes by the ionization of argon. In later types, the envelope walls have been metallized by reducing salts of silver or similar metal. Later the commercial impracticability of using silver, its cost, inability to adhere tenaciously, and marked light-reflecting properties, have brought about the use of colloidal graphite films. Such deposits formed with the aid of aqueous graphite dispersions, and the various coating methods⁶ depicted in Fig. 3, provide conductivity, opacity, and gettering characteristics.

PRODUCTION

In conclusion, the stages of manufacture might be summarized or indicated as follows:

(1) The Pyrex bulbs, as coming from the glass makers, are cleansed thoroughly with chemical washes, and coated on the interior face with fluorescent powders by mechanical means already discussed.

(2) After excess screen material is removed with a brush as the bulb is rotated mechanically, a neck of nonex glass is fused to the bulb. Coating treatment follows.

(3) The precision-made electrode parts are then assembled, great care being taken in alignment and spacing tolerances, and cleanliness of all elements involved. The microscopically-clean gun apertures are aligned, welded or cemented by hand into position, and examined critically to insure a clean image spot. The tube base is then mounted carefully on the tube so that the screen pattern will be horizontal at the time of later operation.

(4) Each tube is operated until its characteristics are stabilized. An electrical inspection follows of emission, deflecting-plate sensitivity, beam focus and center, screen efficiency, anode currents, and residual gas-content. Representative tubes from each production batch are given more critical analysis at periodic intervals during life-tests.

Many readers will remember when vacuum tubes sold for around twenty dollars each, in contrast to the present cost of less than one dollar. Cathode-ray tubes are now passing through similar stages of mass production and decreasing costs. The opinions of competent observers in the field, supported by the increasing number of new patents filed on the production and design of television tubes, suggest still other developments are impending.

⁵Radio Engineering, page 13, January, 1937.
⁶Radio Engineering, page 7, December, 1935.

HITS OF THE YEAR

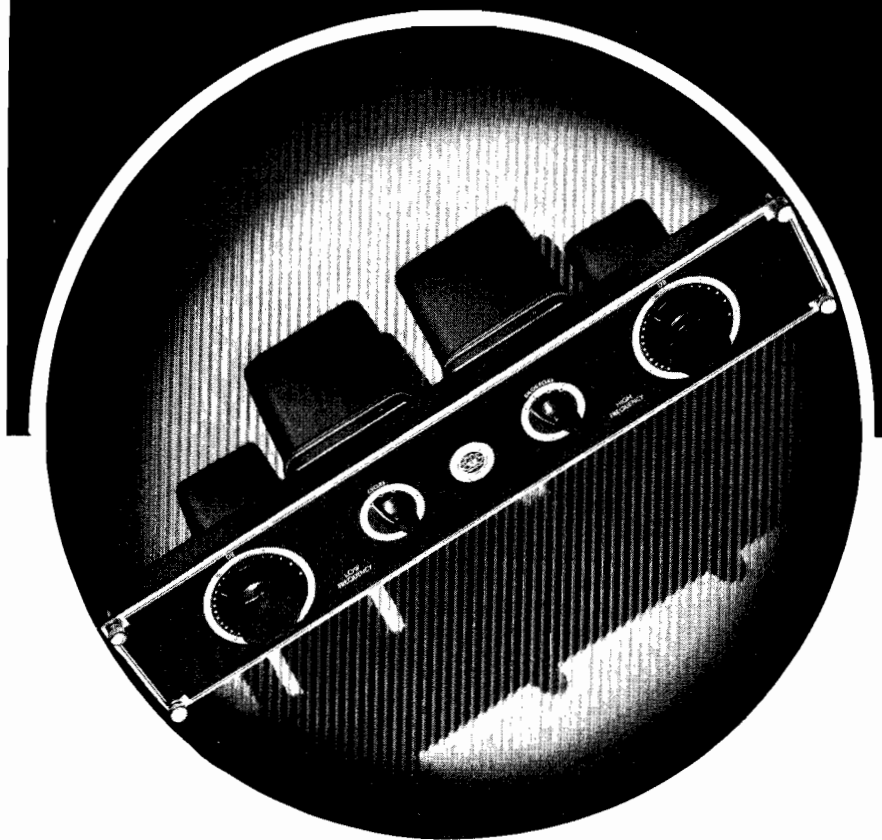

Appearance of 3A, 3D, 3R, 4B equalizers

UTC EQUALIZERS

UTC MODEL 3A EQUALIZER. The UTC 3A equalizer is an ideal universal equalizer for broadcast and recording service. It combines tap switches and pad controls permitting accurately controlled equalization up to 25 DB at both low and high frequencies. This unit will equalize telephone lines, pickups, cutting heads, sound on film, and other applications of a similar nature. Net price to broadcast stations..... **\$85**

MODEL 3D UNIVERSAL ATTENUATOR. The UTC model 3D attenuator is similar to the 3A equalizer, but is designed to ATTENUATE the low or high frequencies. The low frequency control consists of a switch for adjusting the point at which cutoff starts to 100, 175 or 250 cycles, and a calibrated pad control to adjust the slope of the attenuation curve. The high frequency portion is tapped at 4000, 6000, 8000 and 10000 cycles with a similar attenuation control. This type of equalizer finds many applications in recording, dialogue equalization, and P.A.—theatre applications. Net price to broadcast stations **\$75**

UTC MODEL 3R EQUALIZER. The UTC Model 3R equalizer combines the high frequency equalizer sections of the 3A unit and the low frequency attenuator section of the 3D unit into one equalizer ideal for disc recording. The low end can be attenuated to the exact degree to prevent overrunning the track and still obtain the best low frequency response possible. The high frequency equalizer compensates for the loss of highs normally encountered in the mechanical part of disc or film recording and also increases the ratio of signal to noise at the scratch frequencies. Net to broadcast stations **\$75**

MODEL 4B SOUND EFFECTS FILTER. The UTC model 4B filter is an improved design based on the sound effects filter developed by UTC for the Columbia Broadcasting System. The low pass control has cutoff frequencies of 500, 1000, 2000, and 3000 cycles and incorporates a pad control to govern the rapidity of attenuation. The high pass section has a switch for cutoff frequencies of 500, 1000, 2000 and 4000 cycles, with a calibrated attenuator. Net price to broadcast stations..... **\$70**

HAVE YOU A COPY?

If not . . . WRITE for the UTC BROADCAST BULLETIN, describing transformer, equalizer and amplifier components for every broadcast and recording application.

UNITED TRANSFORMER CORP.

72 SPRING STREET

NEW YORK, N. Y.

EXPORT DIVISION: 100 VARICK STREET NEW YORK, N. Y. CABLES: "ARLAB"

A Reputation built on a tubular condenser



Small, but mighty important. Twenty-eight years of engineering experience and research are incorporated in the design and manufacture of the small C-D paper tubular condenser. No wonder they far excel, outlive and outsell all

others. Described in detail in Catalog No. 151A free on request.



CORNELL-DUBILIER ELECTRIC CORPORATION

1005 Hamilton Boulevard, South Plainfield, New Jersey



Frequency Measuring Service

Many stations find this exact measuring service of great value for routine observation of transmitter performance and for accurately calibrating their own monitors.

MEASUREMENTS WHEN YOU NEED THEM MOST

at any hour every day in the year

R.C.A. COMMUNICATIONS, Inc.

Commercial Dept.

A RADIO CORPORATION OF AMERICA SERVICE

66 BROAD STREET

NEW YORK, N. Y.



SIXTH ANNUAL MEETING

INSTITUTE OF THE AERONAUTICAL SCIENCES

THE SIXTH ANNUAL MEETING and smoker of the Institute of the Aeronautical Sciences is to be held from January 24-27 inclusive at the Pupin Physics Laboratories, Columbia University, New York City.

This gathering has one of the most comprehensive aeronautical programs that has ever been prepared. Each session has been organized so that it should

be of interest to all members as well as to specialists.

Professional papers will be presented, surveys of specialized fields will be given by experts, and an attempt will be made in the discussions to estimate the state of knowledge and the avenues of research that appear the most useful for future progress.

TELECOMMUNICATION

(Continued from page 28)

and the Union of South Africa and is being installed in Hungary, Czechoslovakia, Russia, and in South America.

The Lorenz Company developed the only instrument landing system now in commercial operation anywhere in the world.

TELEVISION AMPLIFICATION

(Continued from page 19)

grouped about multiples of f_0 , where

$$f_0 = \frac{\text{(number of lines per frame)}}{\text{(number of frames per second)}}$$

There are little utilized bands between each of these energy groupings which may possibly be used for other purposes.

(4) The amplifier for television frequencies must have a satisfactory transient response, but this requirement is not difficult to satisfy.

(5) By means of various correction networks, the low and high-frequency steady-state response of the R-C coupled amplifier may be made adequate for television-frequency amplification.

BIBLIOGRAPHY

Proceedings of Institute of Radio Engineers

¹Lane—"The Resistance-Capacity Coupled Amplifier in Television," Vol. XX, No. 4, April, 1932, page 722.

²Robinson—"Theoretical Notes on Certain Features of Television Receiving Circuits," June, 1933, page 833.

The Wireless Engineer and Experimental Wireless

³Smith—"Amplification of Transients," June, 1933, page 296.

⁴Builder—"The Amplification of Transients," May, 1935, page 246. (References 3 and 4 should be considered together.)

⁵Oakey—"The Distortionless Amplification of Electrical Transients," May, 1931, page 245.

Marconi Review (London)

⁶Keall—"Correction Circuits for Amplifiers," No. 54, May-June, 1935, page 15. See also No. 56, Sept.-Oct., 1935, page 10, for second installment.

Television and Short Wave World (London)

⁷Walker—"The Design of High Definition Amplifiers."

Part I, August, 1935, page 473.

Part II, September, 1935, page 525.

Part III, November, 1935, page 672.

Part IV, January, 1936, page 151.

Part V, May, 1936, page 305.

⁸Nagy—"The Design of Vision-Frequency Amplifiers."

Part I, March, 1937, page 160.

Part II, April, 1937, page 220.

Part III, May, 1937, page 279.

⁹Beardsall—"Valve Couplings for Television Frequencies," February, 1936, page 95.

¹⁰Congreve—"Automatic Grid Bias in Television Receivers," March, 1936, page 167.

Books

¹¹Terman—"Radio Engineering," McGraw-Hill. Second Edition, Chapter VI, Section 50.

NOTES AND COMMENT

(Continued from page 21)

will give rise to a frequency change and thus cause an undesirable frequency-modulated, broad wave. The current through a practical choke does vary and in varying causes a comparatively large change in plate voltage. The design should be such that the plate voltage never goes under the value at which the frequency starts to change, for best work with the telephone. The change in frequency caused by plate-voltage change is greater at ultra-short waves, but is probably less for this type of modulation than for other types. In general, it may be stated that the 955 is the best tube for this type of service because it will, under the usual conditions, give a steadier wave and will do so with less voltage on the plate. If the 30 tube is to be used, it should be operated so that its oscillator never has voltages lower than about 45 volts applied to its plate.

A. BINNEWEG, JR.

REMOTE PICKUP EQUIPMENT

(Continued from page 10)

ponents, and provided with only one microphone-input position. They are, of course, intended for use at semi-fixed pickup points—newspaper offices, night-clubs, and the like—where no mixing is required and where, in fact, it is often not considered necessary to send a control operator.

Type 12-Y (Collins): Typical of these small equipments is the 12Y unit. This is a three-stage amplifier, of very compact dimensions, designed to be as foolproof and as automatic in operation as a remote equipment can be made. The unit and power supply are contained in a small cabinet (Fig. 11) which is only $3\frac{3}{4}$ by $6\frac{1}{4}$ by 7 inches, and weighs only $4\frac{3}{4}$ lbs. No controls at all are provided on the panel—the gain being adjusted through a screwdriver-type control, and ordinarily left in a fixed position. In order to minimize hum introduction, the power transformer is placed in the a-c cable.

Type 6-L (Gates): The 6-L amplifier is of somewhat larger size—the case being 17 inches long by 7 inches high and 4 inches deep (Fig. 12). As in the previous unit, one microphone input position is provided. A gain control is provided on the panel. The three-stage amplifier utilizes a 6F5 followed by a 6C5 and this by a 6F6 in the output stage. The standard 6-L model has an input impedance of 30 ohms, while the 6-R model provides input impedances of 50, 200, 250 or 500 ohms. This equipment is intended for a-c use only. The power supply is entirely contained, making the equipment complete in one unit.

DOUBLED POWER

for ————— \$239.00



No need asking you, we know you are looking for increased coverage. Do you have sections in your primary area down in the mud or a signal in your secondary area that in spots just exists and that's all? The Gates 17-B Audio Compressor, gentlemen, will do a grand job of pulling this signal up to a level that will completely erase many of these bad spots. One 100 watt reports for the first time hearing his signal in a town 140 miles distant after installing the 17-B. Another reports increased average modulation level of 15%. We'll bet a good cigar the 17-B will give you far more dollar for dollar signal improvement than any other investment you ever made. Yes a 3 to 4 Db. audio signal increase is equal in many cases to doubling power and that's what the 17-B will do for you at \$239.00 and with quick delivery assured.



A DYNAMIC Reproducer

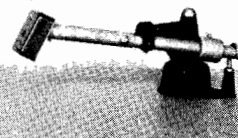
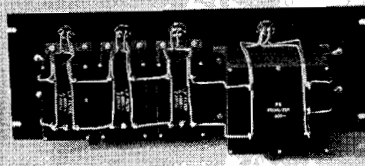

WITH ASSOCIATED NET WORK FOR HIGH FIDELITY LATERAL REPRODUCTION.

Ask for our latest "Sound Apparatus Bulletin" on Modern Reproducing

SOUND APPARATUS COMPANY

150 WEST 46TH STREET

NEW YORK CITY



VETERAN WIRELESS OPERATORS ASSOCIATION NEWS



W. J. McGONIGLE, President

RCA Building, 30 Rockefeller Plaza, New York, N. Y.

H. H. PARKER, Secretary

OFFICERS AND DIRECTORS

THE FOLLOWING Officers and Directors were elected by ballot by the membership for the year 1938: William J. McGonigle, President; Arthur F. Wallis, Vice-President; H. H. Parker, Secretary; W. C. Simon, Treasurer; and the following members were elected Directors: C. D. Guthrie, U. S. Maritime Commission Radio Supervisor; Fred Muller, Sales Engineer, Collins Radio Company; George H. Clark, Information Department, RCA; William J. McGonigle, New York Telephone Company; A. A. Isbell, Commercial Manager, RCA Communications; W. S. Fitzpatrick, Secretary Board of Editors, *RCA Review*; A. J. Costigan, Traffic Manager, Radiomarine Corp.; A. F. Wallis, Commercial Representative, Mackay Radio and Telegraph Company.

THIRTEENTH ANNUAL

AGAIN, we urge you to communicate with your local representative for information concerning the simultaneous cruises to be held by our chapters throughout the country and the world. The New York affair will be held in the beautiful Roof Garden of the Hotel Astor, Times Square, New York City. A delicious full-course dinner preceded by an Astorian Martini cocktail and accompanied by two bottles of delicious Sauterne wine per table of ten persons will be served. A comprehensive program of entertainment and highlights is being planned for your enjoyment. A radio broadcasting orchestra will play for dancing during and after the dinner and the next day being both a Saturday and a holiday we know you will enjoy to the fullest the long evening of jollification and genuine camaraderie on this the occasion of our 13th Anniversary Cruise. Tables of ten will be reserved in advance and such reservation assures you of having a choice location. Tickets are but \$4.00 and are available from any of our officers or committee men.

MIAMI

EBBIE, Secretary of the Miami Chapter, reports: "From the land of excessive electrons comes a report on activities of the 'Sun-Worshippers' Chapter.

"Le Petite secretaire por la chaptaire de sunshine called a meeting for December 16, 1937 (as per our enclosed notice). Chapter material began showing up at 7:30 P.M. and at 9:00 were still excusing their way into a bubbling over mixture of radiotics. The meeting never did take place—instead, it was decided to dispense with the dull business of holding a meeting, elections, etc., until early in January.

"Among the attendants were the yachting boys Frank, Reb and Alex Vadas. The Eastern Air turnout was good—L. C. Bishop, R. D. Phillips (ex-Ft. Lauderdale Police) and others. T. R. T. was represented by W. D. Thomas, Bob Brackett of 1912 vintage, and yours truly. C. J.

Corrigan was there with his ten farads capacity for lager, David Harpley just fresh from New York (a Dan Cupid quest 'tis rumored), A. Durio, unassigned but willing, Mr. Totman of the D. O. C. (Dep't of Commerce), Maynard (Goldbug) Davis and several half dozen others joined in making this a very enjoyable confab.

"New members signed up at the meeting are: Earle Hill, who commenced in this business in 1916 with the Marconi Company and saw service in the Army and on various ships; Ernest Thomas Luscombe, in the U. S. Navy back in '20 and later served on land, at sea and in the air and is at present with Tropical at Hialeah; Roy A. Demeritt, also of land, sea and airways radio services having been in the game since 1918; and G. Burgess, at present Superintendent of coastal station WOE at Lake Worth, Florida.

"And thus I take leave"—(and Ebbie signs) V. H. C.-E., 2. and underlines it with notation "Not a Chemical." They are his initials.

BOSTON

AT A MEETING held at the Hotel Manger, in the Canadien Room, Boston, Mass., Monday, December 6th, 1937, Officers of the Boston Chapter, for the year 1938, were elected. Chairman Charles Kolster, U. S. Radio Supervisor, our hard working Chairman, "did not choose to run." Harry Chetham, who did such a good job as secretary for several years, was nominated and elected Chairman, unanimously; Guy R. Entwistle, President of the Massachusetts Radio and Telegraph School, was re-elected Vice-Chairman; Raymond F. Trop, Treasurer of the above mentioned School, was re-elected Treasurer of the Chapter; and Bart McCarthy, Clerk at the Boston office of the Federal Communications Commission, was elected Secretary. Ted McElroy, world's fastest Radio Operator, was elected Director of Publicity.

Among those present were: Norman Filson of Waltham who twenty-five years ago operated on the Eastern Steamship fleet, the *Camden* and the *Belfast* on the Bangor run, and now holding a responsible position in a local baking concern; Arthur W. Mayer, who continues in the radio business in Boston; Elmer Walters, from Topsfield, one of our SOS section operators who distinguished himself in the famous *S.S. Boston-S.S. Swift Arrow* wreck off Point Judith, R. I., in July, 1924. During the emergency Mr. Walters remained at his radio post continuously for over twenty-four hours until the *S.S. Boston* was beached.

SAN FRANCISCO

ALL THOSE INTERESTED in attending the Dinner-Cruise of the San Francisco or in obtaining information concerning VVOA activity in that section of the country should communicate with Gilson V. Willets at 1434, 26th Avenue, San Francisco,

Phone Overland 7361, who says "I want to hear from those 'who have the time and will devote a part of it to the systematic building of VVOA strength on the Pacific Coast'."

GVW, incidentally, now conducts a column in a San Francisco paper titled "Dollarmakers" which includes interesting and humorous facts and situations and cartoons depicting interesting scenes. Good luck, GVW!

CANADA

WE HAVE a very interesting account of the experiences of one of Canada's more prominent veteran radiomen, Mr. D. R. P. Coats: "1910—built the usual receiving set. January 1911—quit my job and joined the British School of Telegraphy, London, England, where I took a course in Marconi and Poulsen Arc Wireless, submarine cable, telegraphy, etc. During that course worked on standard Marconi coherer equipment with 'Tune A' and 'Tune B' spark transmitters. Later had an English Marconi 1½ kw fixed spark transmitter and magnetic detector. Harold Bride of the *Titanic*, Evans of one of their ships mixed up in the *Titanic* case, and a number of other men who afterwards 'made' the newspapers, were students with me at that time. November, 1911—sent to Canada to work on the Trans-Canada line of the Pacific Cable Board. April, 1913—joined Canadian Marconi Company and went to sea. Served on more than a dozen vessels; was chief operator on the *S.S. City of Sidney* which was lost on the rocks of Sambro in March, 1914, and was lone operator aboard the *S.S. Morwenna* which was shelled and torpedoed by an enemy submarine in May, 1915.

"Subsequently served as manager and chief instructor of the Canadian Marconi Company's school for operators at Montreal for nigh onto three years and was publicity manager and one of the earliest broadcasters in Canada while employed with that company."

At present Mr. Coats is employed as Manager of Public Relations of radio station CKY, of Winnipeg, Manitoba, Canada, a station of 15,000 watts and one of our "Friendly Neighbor's" best known broadcasting outlets. Mr. Coats is quite anxious to establish a Chapter of our Association in his section of Canada. We say, more power to him, and assure him of our earnest cooperation.

PERSONALS

PETER PODELL, Charter Member, writes: "I am ready for the Cruise. What's new?" We refer Peter and others interested to another section of this page containing full details of our forthcoming 13th Annual at the Astor Hotel on February 11, 1938. We'll see you there, Peter. He is connected with Chapet Motor Company at Boscobel Avenue at 167 Street and Jerome Avenue in NYC.

BLILEY CRYSTALS

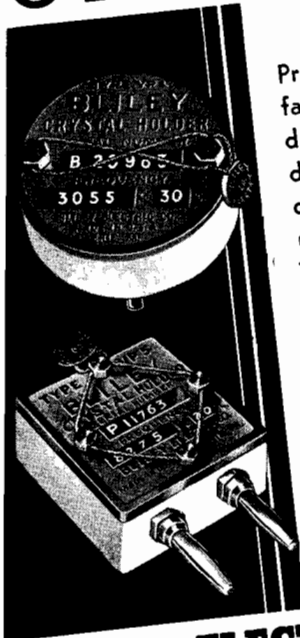

Precision manufacturing facilities and correctly designed holders assure dependable frequency control for any frequency from 20 KC. to 30 MC. For technical recommendations on standard or special applications, a statement of your requirements will receive immediate attention. A technical catalog is available on request.

BLILEY ELECTRIC COMPANY
UNION STATION BUILDING
ERIE, PA.

February COMMUNICATIONS

●
annual

NATIONAL ASSOCIATION
OF BROADCASTERS
CONVENTION NUMBER

●
TO BE DISTRIBUTED TO ALL
EXECUTIVES AND ENGINEERS
AT THE CONVENTION . . .

WILLARD HOTEL
WASHINGTON, D. C.
FEBRUARY 14, 15, 16

●
FINAL CLOSING DATE FOR ADVERTISING,
FEBRUARY 5TH . . . MAKE YOUR SPACE
RESERVATION NOW.

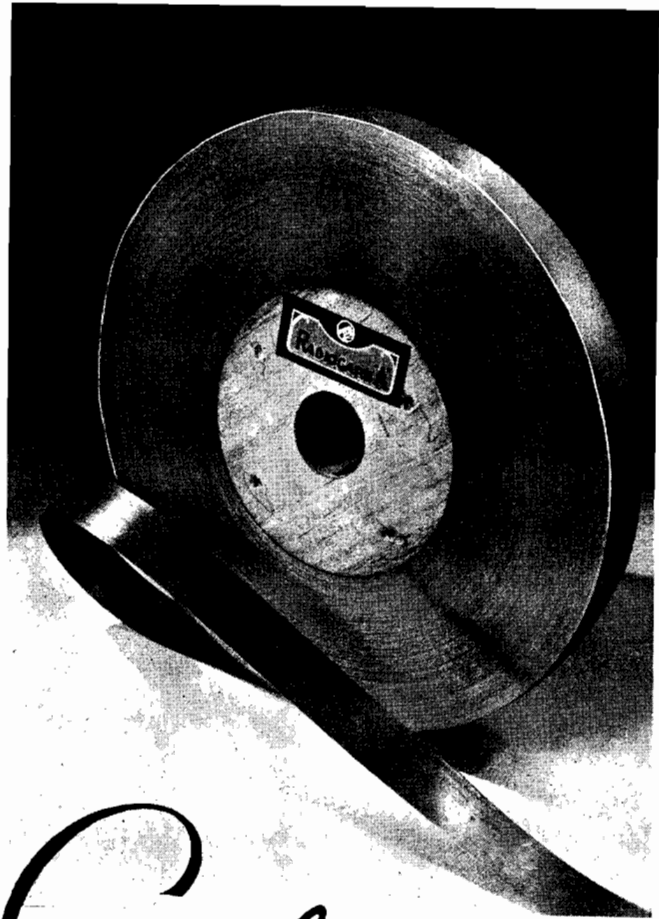

Carbonized NICKEL



The almost perfect thermal radiator. The favorite material for receiving-tube plates or anodes. Laboratory-controlled RadioCarb A and other W.B.D. carbonized nickels insure:

- Jet black, smooth, adherent, flexible carbon coating that will not peel or dust off in subsequent fabrication.
- Free from loose carbon, slivers, waves, seams, rough edges, hydrocarbons. Minimized sulphur and other impurities.
- Available in all widths up to 4". Thickness from .005" to .015".

ASK for samples and quotations. Let us explain how you can save money and produce better tubes with W.B.D. carbonized nickels.



WILBUR B. DRIVER CO.
NEWARK, NEW JERSEY

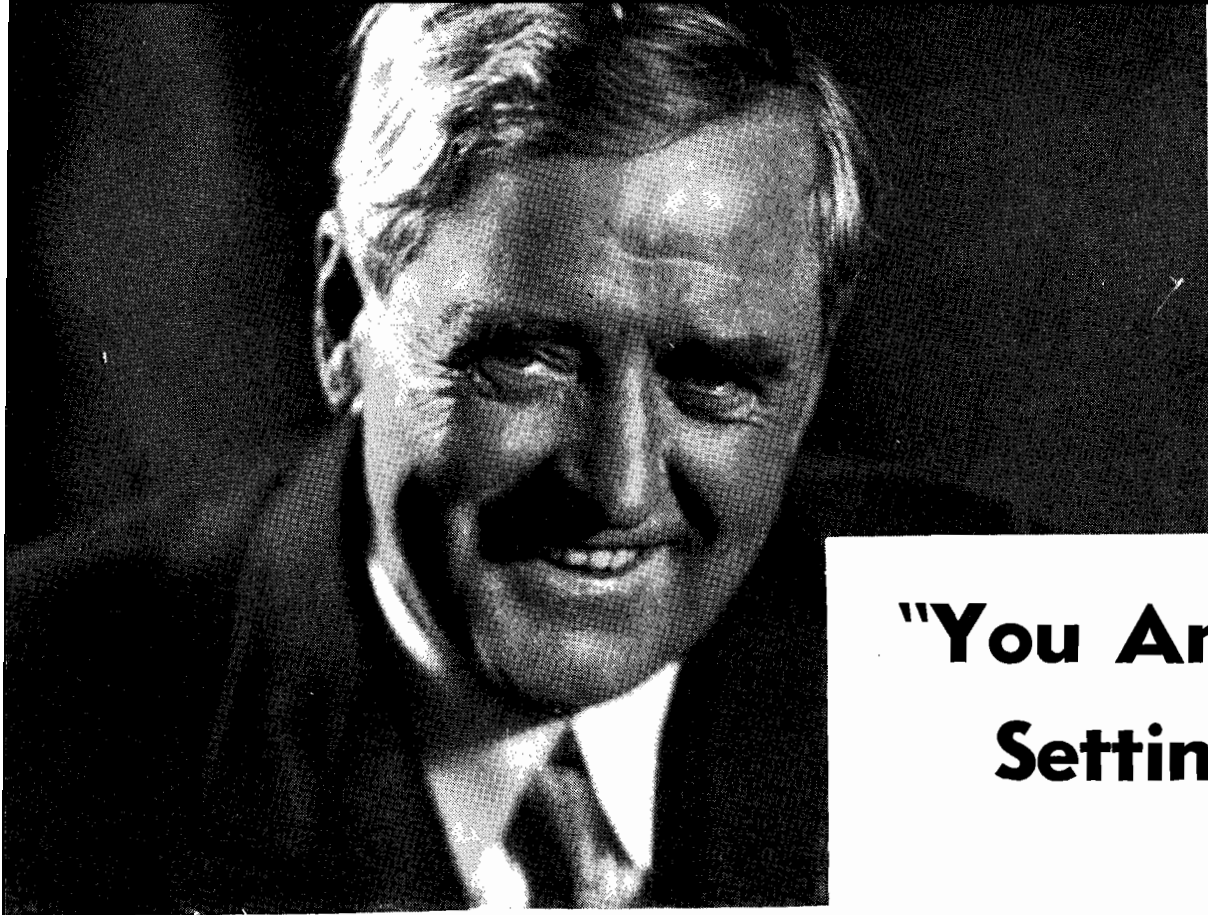

"You Are Setting the Pace!"

That's what the leading engineers say about COMMUNICATIONS

TEAR THIS OUT

AND MAIL TODAY

**COMMUNICATIONS,
19 East 47th Street,
New York City**

Gentlemen:
I remit \$..... herewith. Please enter 1 year
subscriptions for the following:

Name
Address
City-State
Occupation
Employed by

Name
Address
City-State
Occupation
Employed by

Name
Address
City-State
Occupation
Employed by

Name
Address
City-State
Occupation
Employed by

Radio Engineers are conservative, not given to brash statements. But the first and subsequent issues of COMMUNICATIONS must have had plenty on the ball! Our Editors' mail has been chock full of laudatory comments. Future issues will continue to have outstanding material, valuable to every executive and engineer engaged in any phase of the art of radio and communications.

If you are a radio, electrical, communications or industrial engineer, executive, department head or factory technician you can secure a year's subscription to COMMUNICATIONS (twelve issues) for only \$1.00 by using the Group Subscription Plan.

Regularly a yearly subscription to COMMUNICATIONS is \$2.00—but in groups of four or more, the subscription rate is only \$1.00 each per year. Your occupation must be stated.

Use the convenient form printed herewith. Your co-workers will sign up with you at the half-price rate if you tell them about this "G.S.P." All the important news about every phase of radio and communications appears *first* in COMMUNICATIONS. Sign up your group today.

**COMMUNICATIONS: 19 E. 47th ST.
NEW YORK, N. Y.**

 When mailing a check (or money order) for a group of subscriptions, use this convenient form.

THE MARKET PLACE

NEW PRODUCTS FOR THE COMMUNICATIONS FIELD

HYGRADE SYLVANIA 6J8G

A new triode heptode converter tube, Type 6J8G, which is in many respects similar to tubes which have been available in Europe for one or two seasons, has been announced.

This tube combines a triode oscillator element with a heptode converter section, so designed as to avoid oscillator frequency drift with change in applied a-c voltages. Although the basing arrangement of this tube is such that it may in some applications be substituted for Type 6A8G, with slight realigning, it is not primarily intended for use in this manner.

As compared with 6A8G, the reduction of some of the interelectrode capacities is an important advantage in Type 6J8G. High conversion gain is maintained at frequencies of 18 mc and above, and the ratio of signal to noise is materially improved. The exceptionally high plate resistance of 4.5 megohms makes it possible to use a high-quality i-f transformer with marked advantage in gain. The selectivity of a high Q tuned circuit is not appreciably impaired by shunting the plate resistance of this tube across it. High input impedance is maintained under all normal operating conditions.

Further facts may be secured from *Hygrade Sylvania Corporation*, 500 Fifth Ave., New York City.—COMMUNICATIONS.

HARVEY MARINE 12

The marine 12 is a compact and sturdy radio-telephone installation designed especially for marine service.

Both transmitter and receiver are housed in a single compact cabinet cushioned on rubber and are crystal controlled. There are but three main controls, all of which are located on the front panel and clearly marked for ease of operation. The central control knob selects any one of three transmitting and receiving frequencies simultaneously. There is also a receiver volume control as well as an on-off switch. The use of a loudspeaker permits incoming calls to be received without the use of headphones. Both speaker and handset may be mounted at any convenient point near the operating position.

The power section consists of a motor generator which may be installed at some distance from the main unit. Provision is made for operation from any one of the following voltage sources: 12-volt, 32-

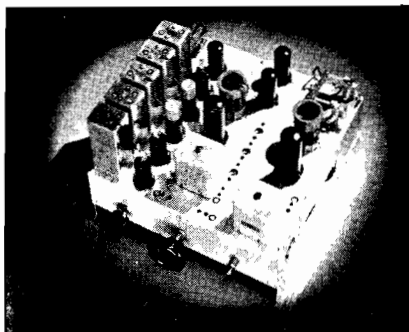

volt, 110-volt direct current; or 110-volt, 60-cycle, a-c.

Literature on this unit is available from *Harvey Radio Laboratories, Inc.*, 25 Thorndike St., Cambridge, Mass.—COMMUNICATIONS.

AIRCRAFT MICROPHONE

The new Universal aircraft microphone is shown in the accompanying illustration.

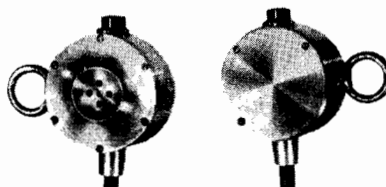

It is light, weighing but eight ounces including cable. The body is of Dural, and the instrument includes a special push-button switch for single or double circuit or any special switching arrangement that may be required.

Further information may be secured from the *Universal Microphone Co.*, Inglewood, California.—COMMUNICATIONS.

CONDENSER MOUNTING BRACKETS

A universal mounting bracket has been applied to the C-D Type TJ-U line of

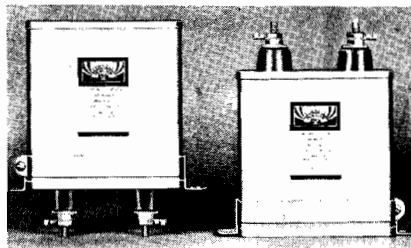

high-voltage dykanol filter capacitors. The new universal mounting permits the condenser to be mounted either upright or inverted as shown in the accompanying illustration.

The C-D dykanol line of high-voltage capacitors is manufactured by *Cornell-Dubilier Electric Corporation*, South Plainfield, N. J.—COMMUNICATIONS.

CRYSTAL UNIT

The new Type B5 crystal unit is manufactured for the 40 and 20 meter bands.

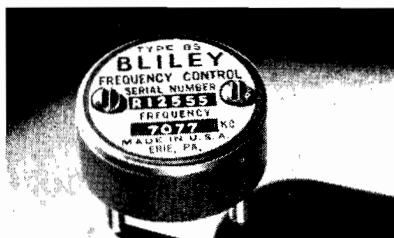

It consists of a low-frequency temperature coefficient quartz crystal, completely mounted and calibrated in a low-loss crystal holder specifically designed to take full advantage of the better characteristics of this new crystal.

The B5 unit for 40 meters has a higher activity, and will safely carry 35 percent more crystal current than the LD2 40-meter unit which it now replaces. The crystal is low drift, and has a maximum frequency temperature coefficient of 4 cycles/mc/°C.

Literature is available from *Bliley Electric Company*, Union Station Bldg., Erie, Pa.—COMMUNICATIONS.

RCA-884

A new gas triode for radio equipment manufacturers has recently been made available. This tube is designated as the RCA-884.

The 884 is electrically like RCA-885, except for heater rating. The 884 has a 6.3-volt heater which facilitates the use of this tube with other 6.3-volt tubes in the design of sweep-oscillator equipment. It is supplied with a 6-pin, small shell, octal base.

More detailed information on this tube is available from the *RCA Radiotron Division, RCA Manufacturing Co., Inc.*, Camden, N. J.—COMMUNICATIONS.

STUDIO PATCHING NETWORK

The Type 449-A adjustable attenuator is a small, compact, balanced-H unit designed for use in broadcast and recording studios. Among its applications are adjusting impedance and volume levels between studio circuits, and to pad out between incoming lines and studio equipment. Attenuation and impedance ranges are as follows:

500 to 500 ohms—0 to 60 db in 10-db steps
500 to 250 ohms—10 to 70 db in 10-db steps
500 to 50 ohms—20 to 80 db in 10-db steps

The case is of cast aluminum; the panel is photoetched and finished in black crackle lacquer. Two sets of parallel-connected Western Electric jacks are provided for both input and output terminals. Attenuation is controlled by Western Electric key switches.

Additional information may be secured from the *General Radio Company*, 30 State Street, Cambridge, Mass.—COMMUNICATIONS.



AUTOMATIC MOLDING MACHINE

A completely automatic molding machine, or press, to mold thermo-setting plastics materials of the phenolic base and urea compound types has recently been made. With the hopper filled, the metering device adjusted to feed the proper amount of molding powder and the machine set for correct breathing and curing time and mold temperature, the production cycle will be repeated, automatically and without operating attention, an indefinite number of times.

The machine is intended primarily for the use of single-cavity molds of the positive type. With it custom molders will be able to handle small-lot orders efficiently and economically, and get quickly into profitable production on parts not now economical to mold because of too high costs with the conventional production set-up.

Additional information may be secured from *F. J. Stokes Machine Co.*, Philadelphia, Pa.—COMMUNICATIONS.

COMMERCIAL HEADSET

This new commercial headset features durability and light weight. The response characteristic is substantially uniform throughout the usable voice range, it is said. It is so constructed that it can handle up to an input of 1 watt or more without rattling. The headband used with

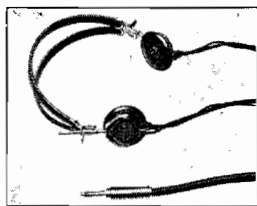

this phone is of an extra rugged leather covered, wire type with spring adjustment. The phone plug is a telephone type design. Phones are said to be desirable for aircraft, commercial operators, and amateurs.

For additional data write to *Trimm Radio Mfg. Co.*, 1770 West Berteau Ave., Chicago, Illinois.—COMMUNICATIONS.

MARINE TRANSMITTER, RECEIVER

The Model D-50 fifty-watt marine transmitter and receiver, shown in the accompanying illustration, operate from 32 or 110-volt ship supply, or 110-volts a-c. Transmitter and receiver are in heavy steel cabinets. The transmitter is remote controlled from the receiver. Three separate power supplies are used. The receiver is of the superheterodyne type and is equipped with a visual tuning indicator.

Complete information may be secured from *Sound Products*, 704 North Curson Ave., Hollywood, California.—COMMUNICATIONS.

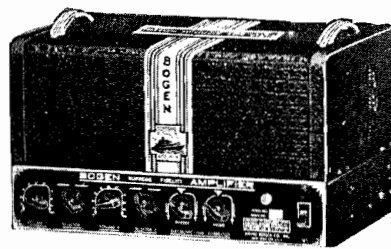
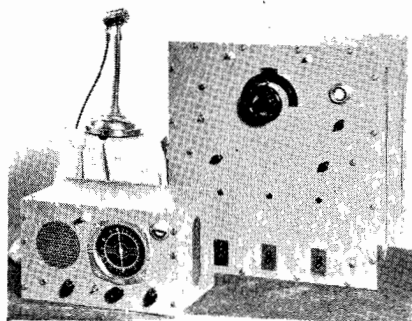

BOGEN AMPLIFIER

Following the introduction of the Bogen CX-30 deluxe amplifier with electronic tone corrector, the model CX-18 has been announced. This unit duplicates the features of the original model with 18 watts output.

CX-18 has dual channel device with separate controls for high and bass ranges, facilitating tonal adjustment; also a unique preamplifier stage said to reduce hum.

Four-channel input for two mikes and two phone pickups are provided. The gain is 128 db.

Complete literature may be had by writing the *David Bogen Company*, 663 Broadway, New York City.—COMMUNICATIONS.

PHOTOTUBE

Latest addition to the G-M Visitron line of phototubes is Type 62A, a small size unit only 2 inches high. It has all the performance characteristics of larger G-M phototubes and is especially adapted to small size apparatus. Dimensions are: overall height (not including prongs) 2 inches; bulb diameter $\frac{7}{8}$ inch; sensitive plate height $\frac{3}{4}$ inch; plate width $\frac{5}{8}$ inch; distance from bottom of base to center of sensitive plate $1\frac{1}{2}$ inches.

This phototube is a product of *G-M Laboratories, Inc.*, 1731 Belmont Ave., Chicago.—COMMUNICATIONS.

PEAK KILOVOLT METER

The peak kilovoltmeter consists essentially of a high-voltage rectifier in series with a condenser and electro-static voltmeter. Briefly, it measures instantaneous maximum potential of the electron charges accumulated on the plates of a low-leakage condenser. The condenser is not of the ordinary type, but is an entirely new design making it practically leak-proof, and it is permanently sealed in the voltmeter. The leakage resistance of the peak kilovoltmeter is approximately 10, to the 13th power ohms and variations in the resistance of the voltmeter are said to have negligible effects on its indications.

The most important function of the peak kilovoltmeter yet developed is the direct measurement of the instantaneous breakdown voltage developed by ordinary induction spark coils. Some of the other meas-

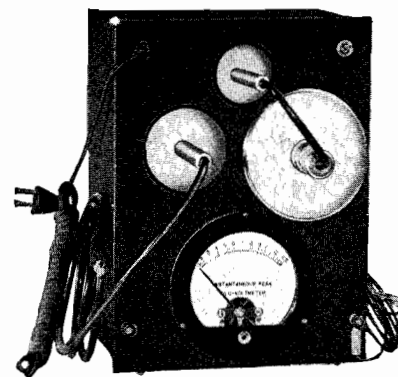

urements, for which the kilovoltmeter is suited, are measuring the potential difference between the first positive and first negative piece of damped sine wave, measurements of surge voltages of very short duration, and indicating the maximum value of pulsating d-c voltages.

Ranges manufactured are from 100 volts minimum readable value to 16,000 maximum, but experiments are now being conducted in order to make the instrument suitable for indicating even higher voltages.

The peak kilovoltmeter is a product of *The Hickok Electrical Instrument Co.*, 10514 Dupont Ave., Cleveland, Ohio.—COMMUNICATIONS.

MARINE SPEAKER

One of the most recently announced speakers for marine use is shown in the accompanying illustration. It is a compact re-entrant type of horn, 14 inches in diameter and 10 inches deep, having a base of heavy aluminum casting and heavy aluminum spinning. It uses a driving unit made of Alnico steel and Armco iron. The driving unit and connections are all enclosed, making a completely waterproof speaker

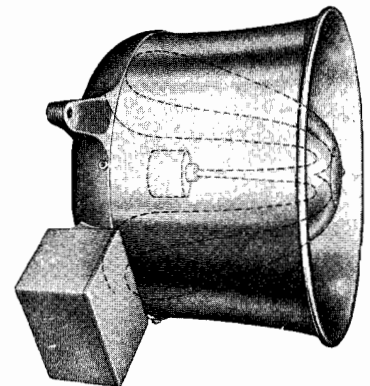

that is not affected by temperature or humidity.

Used as a loudspeaker the unit is said to deliver 100 db of sound at 10 feet from the horn with an input of one watt. Used as a microphone, it will pick up sound outdoors from distances up to 100 feet.

This marine speaker is a product of the *Racon Electric Co., Inc.*, 52 East 19th Street, New York City.—COMMUNICATIONS.

RECORD CHANGER

A new record changer is being introduced. This record changer will play either eight 10-inch or eight 12-inch records. Many unusual features are said to be incorporated in this record changer. It is available in any current, and also with crystal pickup.

Literature is available from the *Garrard Sales Corporation*, 17 Warren Street, New York City.—COMMUNICATIONS.

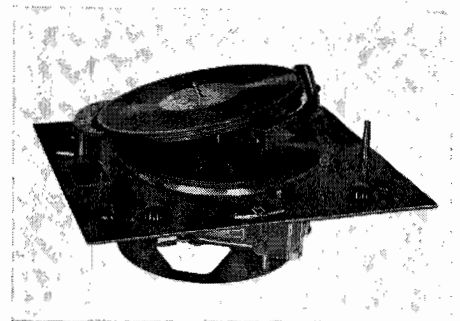

Mr. Engineer—

YOU'LL FIND a big sales advantage when you include the Brush "Hushatone" (pillow speaker) in your new model midget radio. It's easy to modify your output circuit to accommodate this popular accessory.

In the home the "Hushatone" is ideal for use in bed, on a couch or a comfortable chair.

In hospitals and sanitariums it has a natural use. Convalescents and bedridden patients welcome the "Hushatone" because of the pleasure and convenience it gives them.

Get in your order today and gain a definite sales advantage.

The BRUSH DEVELOPMENT Co.
3318 PERKINS AVE., CLEVELAND, OHIO

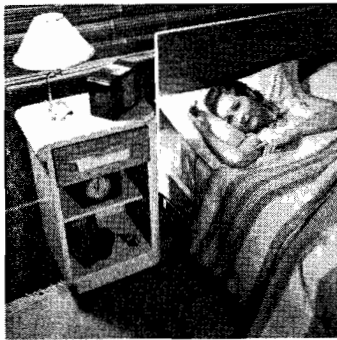

AMPEREX CARBON ANODE TRANSMITTING TUBES

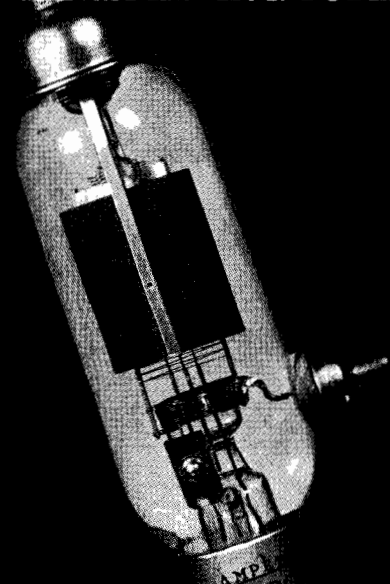

AMPEREX
ELECTRONIC PRODUCTS, Inc.
79 WASHINGTON ST., BROOKLYN, N. Y.

THAT *Tiny Motor*
YOU'VE BEEN LOOKING FOR

Utah
has it!

**65,349 DELIVERED TO THE RADIO
INDUSTRY IN THE LAST 60 DAYS!**

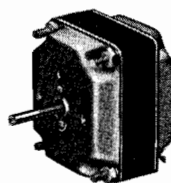

1/3 ACTUAL SIZE

A. C. Here is the 3-wire brushless reversible motor Utah pioneered for the electric tuning of radios. Other branches of industry are finding countless applications for this versatile little motor. It can be supplied for any A. C. voltage from 6 to 115.

Here is an arrangement that demonstrates the adaptability of these motors to a variety of applications. This Utah motor has an automatic clutch, a gear train, manual control shaft and mounting plate. Other gearing may be substituted. Silver contacts are used on the Thermostatic Switch and Muting Switch. Motor is squirrel cage induction type with self-aligning oil-less bearings.

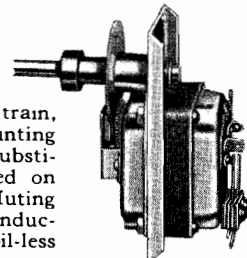

1/3 ACTUAL SIZE

D. C. Here is the 3-wire universal brush type, for D. C. and A. C., 25-50-60 cycles. Automatic clutch and driving pinion are standard equipment. All Utah motors are easily adapted to a variety of layouts. Though exceptionally compact, they are built to take the rigorous starting, stopping and reversing required by many applications.

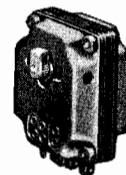

1/3 ACTUAL SIZE

Send your specifications
for prices and details.
Address Dept. C1.

**PATENTS ISSUED AND PENDING
ON ABOVE MOTORS**

UTAH RADIO PRODUCTS CO.
CHICAGO, U. S. A.

TORONTO BUENOS AIRES
ONTARIO, CANADA (UCOA RADIO PRODUCTS CO.)

"16 YEARS OF LEADERSHIP"

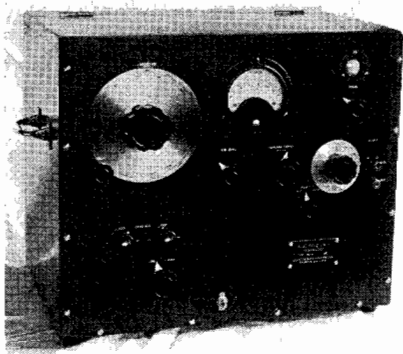

FREQUENCY GENERATOR

The Type 140-A beat-frequency generator, shown in the accompanying illustration, has recently been announced. This instrument has frequency range extending from 20 cycles to 5 megacycles. The voltage range is from 10 millivolts to 10 volts.

Literature is available on the 140-A beat-frequency generator. Write to *Boonton Radio Corporation*, Boonton, N. J.—COMMUNICATIONS.

NEUTRALIZING CONDENSER

Another new condenser for transmitting has just been developed in the laboratories of the *Hammarlund Manufacturing Company, Inc.* It is a neutralizing condenser and is called the "N-10." This newest addition to the Hammarlund transmitting condenser family is exceedingly compact and designed for horizontal adjustment.

It was heavy aluminum round edge plates, polished over all surfaces, which are mounted on a pair of strong Isolantite bars. These bars are so mounted that they will not shift or pull out of position. The movable plate of this condenser is controlled by a finely threaded screw, allowing micrometer control. A positive locking nut permits extremely accurate settings. The special design of the adjusting screw prevents any possibilities of plate touching or short circuits. The capacity range of the "N-10" is from 2 to 10 mmfd, while the air gap can be varied from 1/16" to 5/8". At the minimum spacing, the peak voltage rating is 3000. The base is drilled for 2-hole base mounting. The condenser is only 2 5/8" high by 1 13/16" deep.

Additional information may be secured from the *Hammarlund Manufacturing Co., Inc.*, 424 W. 33rd St., New York City.—COMMUNICATIONS.

DYNAMOTORS

Three new types of "Pinco" dynamotors have recently been announced. These addi-

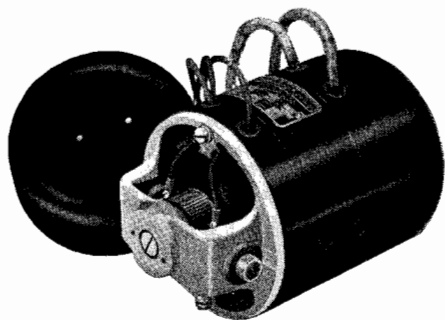

tions to the present Pioneer line are types PS, CS and TS.

The end-bracket and brush-holder design in these units give easy accessibility to the commutator for cleaning and inspection. The brush-holders are said to assure proper brush action and brush spring can not touch the commutator. A screw plug in the hub of the end-bracket enables adding grease without taking the dynamotor apart.

The armatures run on grease sealed bearings to insure smooth and quiet operation.

Type PS is designed for outputs up to 45 watts with either 6 or 12 volts. Type CS is intended for outputs up to 300 watts intermittent or 250 watts continuous duty. Type TS will give outputs up to 525 watts intermittent, or 400 watts continuous.

More detailed data may be secured from the *Pioneer Gen-E-Motor Corporation*, 466 West Superior St., Chicago, Illinois.—COMMUNICATIONS.

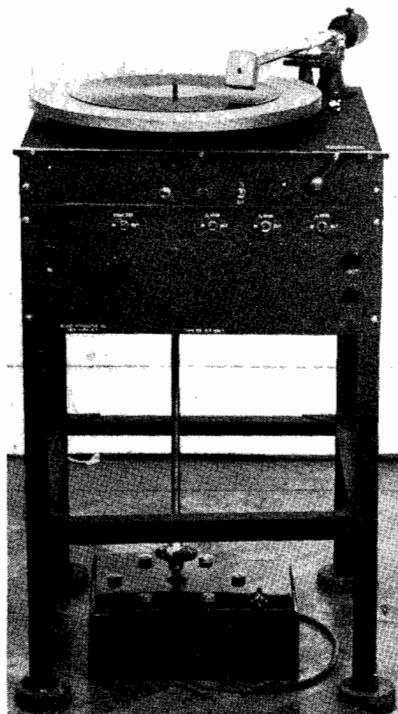

REPRODUCING TABLE

A complete reproducing table for high-fidelity lateral reproduction is shown in the accompanying illustration. This table includes a dynamic pickup which is said to have a flat frequency response from 40 to 8000 cycles. The moving coil principle is featured. A variable equalizer and set of low-pass filters make it possible to control bass, high response and background noises more advantageously, it is said.

Special literature on this reproducing system is available from *Sound Apparatus Company*, 150 West 46th St., New York City.—COMMUNICATIONS.

DECIBEL METER

A rectifier-type power-level indicator and voltmeter, in which a new circuit network provides improved uniformity of operating characteristics, has been introduced by the *Weston Electrical Instrument Corporation*, Newark, N. J. Known as the Model 695 Type 11 (eleven), the unit has a constant internal resistance of 20,000 ohms, both into the instrument from the line under



test, and from the instrument into the network toward the line.

This feature eliminates consideration of the load effect of the instrument on the circuit, since at 20,000 ohms on a 500-ohm circuit the load of the instrument is generally negligible.

Further information may be secured from *Weston Electrical Instrument Corp.*, 612 Frelinghuysen Ave., Newark, N. J.—COMMUNICATIONS.

SHURE MICROPHONE

Unique feature in microphone design is the "directivity control" switch found in the Shure "Tri-Polar" model.

The switch knob has been designed to appear as an integral part of the microphone case and permits instant selection of uni-directional, bi-directional or non-directional characteristics. This is accomplished by turning the switch knob so that the small chromium spot is directly beneath the desired characteristic as shown on the designation plate. The three available directional adjustments are indicated by the corresponding easily-recognized polar patterns.

Further information may be secured from *Shure Brothers*, 225 W. Huron Street, Chicago, Illinois.—COMMUNICATIONS.

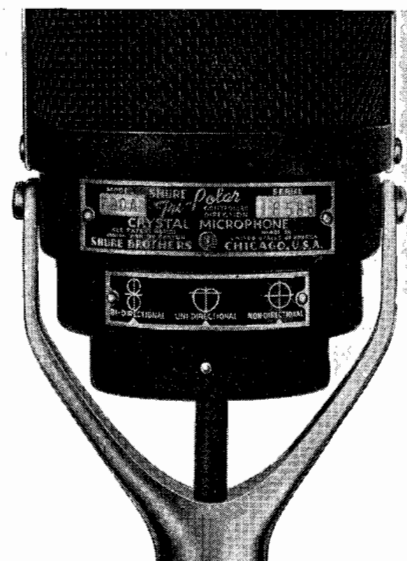

CHAS. EISLER'S
EQUIPMENT HAS PRODUCED
MILLIONS

FOREMOST IN THE ELECTRONICS FIELD FOR OVER 20 YEARS!
Charles Eisler's equipment for the production of radio and electronic tubes, incandescent lamps, X-Ray and cathode ray tubes, photoelectric cells, and neon signs has met the severest demands of industry in operating at maximum production and minimum cost. If you are in the market for any of the above or allied equipment including electric spot welders up to 250 KVA, butt, and arc welders, get in touch with us. Write for our "college and glass working laboratory units" catalog.

EISLER ENGINEERING CO.

750 S. 13th STREET (Near Avon Ave.) NEWARK, N. J.



VULCANIZED FIBRE
PHENOL FIBRE
TAYLOR INSULATION
TAYLOR FIBRE CO., Norristown, Pa.

"THE CRYSTAL SPECIALISTS SINCE 1925"
PIEZO-ELECTRIC CRYSTALS
GUARANTEED Accurate to BETTER than .01%
SCIENTIFIC RADIO SERVICE
Send for **FREE Booklet and Price List!**
UNIVERSITY PARK - - - - HYATTSVILLE, MD.

RADIO IN ITS ENTIRETY!



"B-A" serves the trade with every need in radio—complete 160-page catalog of nationally known radio receivers, public address, parts, supplies and equipment. Orders shipped same day received.

BURSTEIN-APPLEBEE CO.
1012-14 MCGEE ST. - KANSAS CITY, MO.

UP-TO-DATE CATALOG AVAILABLE

USED LABORATORY EQUIPMENT
Weston — G.R. — L&N — G.E., Etc.
Meters — Bridges — Torsion balances — Inductors.
Decade boxes — Analytical balances — Oscillographs.
Tubular rheostats — Signal generators — Condensers.
Write for new list
Louis J. Winslow
200 PENNSYLVANIA AVENUE HILLSIDE, N. J.



Sensation OF THE RADIO FIELD!
● It's the ONLY magazine with the best from ALL branches of radio (except business and entertainment).
● Digests, extracts, reprints from QST, Radio, All Wave Radio, Radio News, Electronics, Service, Communications, Bell System and R.C.A. papers, house organs, over 100 journals.
● Twelve issues for \$2.50 in U.S.A., Canada, and Pan-American countries. Elsewhere, \$3.00 or 12c. Sample copy, 25c.
RADIO DIGEST
7460 Beverly Blvd. Los Angeles



Famous FOR ECONOMY

Throughout the radio industry Gardiner Resin-Core Solder has an outstanding reputation for savings in both time and material. Its uniform water white rosin flux . . . no solvent added . . . permits cleaner work by both expert and inexperienced help. Its high tensile strength insures lasting bonds. Yet, due to modern production methods and tremendous demand, Gardiner Solder costs less than even ordinary kinds. Made in various alloys and core sizes and in gauges as small as 1/32 of an inch. Available in 1, 5 and 20-lb. spools.

Eastern Sales Office and Warehouse:
DAVID M. KASSON & CO., 264 Canal St., New York



4819 S. CAMPBELL AVENUE, CHICAGO, ILL.

POWERFUL, YET GENTLE!
IDEAL JUMBO "3-in-1" CLEANER
BLOWS — VACUUMS — SPRAYS

Powerful—but cleans most delicate electrical or other machinery and instruments without disturbing most precise adjustments. Gives high velocity of dry air at low pressure—absolutely no moisture.

Gets into smallest corners and nooks, removing every particle of lint and dust.

Blows—Vacuums—Sprays—Gives all around service. Portable—weighs only 14 lbs.

Sent on Free Trial
IDEAL COMMUTATOR DRESSER COMPANY
1062 Park Avenue, Sycamore, Illinois



• **There's Always A BETTER Job for A BETTER MAN . . .**



If you're satisfied and content with your present job, you won't be interested in CREI . . . but, if you're ambitious and can see the bright opportunities that lie ahead in Radio for specialized men who have been **Technically Trained . . .** then CREI can help you as it has helped others out of routine jobs into top positions in the Radio Industry.

"Invest" One Cent Now . . . Write Today for **FREE Illustrated Catalog**

Our new booklet "A TESTED PLAN FOR A FUTURE IN PRACTICAL RADIO ENGINEERING" is just off the press. Illustrated and complete with information about your future in Radio. Write today.

Capitol Radio Engineering Institute
WASHINGTON, D. C. DEPT. C-1 NEW YORK CITY
14th and Park Rd., N.W. 29 Broadway

36 years experience
in PERMANENT MAGNETS

We make Permanent Magnets for All Purposes — Stamped, Formed and Cast Magnets — Chrome . . . Tungsten . . . Cobalt . . . Alnico (cast only)

THOMAS & SKINNER STEEL PRODUCTS CO.
1120 E. 23rd ST. — INDIANAPOLIS

WRITE FOR PRICES
LAMINATIONS FOR RADIO TRANSFORMERS
TOOLS — DIES — STAMPINGS



A Leader in Sound Reproduction

Professionals and amateurs alike pronounce Astatic's new Acorn Model T-3 Microphone an outstanding leader in its field. Tilting head on unique swivel mount permits directional or non-directional position to control acoustic feedback. Chrome finish. Complete with interchangeable plug and socket connector and cable.

Write for Literature
LIST PRICE \$25.00



Astatic Microphone Laboratory, Inc.
Dept. M-5 YOUNGSTOWN, OHIO
Licensed Under Brush Development Company Patents

SIMPLAT



10 inch
12 inch
16 inch
200-shot
RECORDS

Cut 'em soft—play 'em hard

Stratified colloidal coating on a flat glass base gives a more durable and uniform blank with extremely wide frequency response. After recording soft, SIMPLAT is easily hardened and can be played back immediately. Under proper treatment, 200 plays may be had from a disc. We highly recommend this scientific record for studio and all professional work.

Write for further information.

We also supply sapphire stylus,
steel CUTTING NEEDLES
and superior
PLAYBACK NEEDLES



CORPORATION
178 Prince Street New York City

Advertising Index

A	
Aerovox Corp.	27
American Lava Corp.	1
Amperex Electronic Products, Inc.	45
Amperlite Co.	32
Astatic Microphone Laboratory, Inc.	48
B	
Bliley Electric Co.	41
Brush Development Co., The.	45
Burstein-Applebee Co.	47
C	
Callite Products Division.	48
Capitol Radio Engineering Inst.	47
Cinaudagraph Corp.	48
Clarostat Mfg. Co., Inc.	31
Collins Radio Co.	32
Cornell-Dublier Electric Corp.	38
D	
Driver Co., Wilbur B.	41
E	
Eisler Engineering Co.	47
G	
Gardiner Metal Co.	47
Gates Radio & Supply Co.	39
General Radio Co.	Third Cover
H	
Hubbard Spring Co., M. D.	36
I	
Ideal Commutator Dresser Co.	47
Isolantite, Inc.	25
J	
Jensen Radio Mfg. Co.	35
M	
Mallory & Co., Inc., P. R.	6
P	
Presto Recording Corp.	33
R	
RCA Communications, Inc.	38
RCA Mfg. Co., Inc.	Back Cover
Racon Electric Co., Inc.	29
Radio Digest	47
Recoton Corp.	32
S	
Scientific Radio Service.	47
Solar Mfg. Corp.	Second Cover
Sound Apparatus Co.	39
Synthane Corp.	5
T	
Taylor Fibre Co.	47
Thomas & Skinner Steel Prod. Co.	47
U	
United Transformer Corp.	37
Universal Microphone, Ltd.	36
Universal Signal Appliances.	48
Utah Radio Products Co.	45
W	
Western Electric Co.	3
Winslow, Louis J.	47
Z	
Zophar Mills, Inc.	32

Callite Products

HAVE TESTED, PROVEN
QUALITY

TUNGSTEN

... Rod, Sheet, Wire and Special Shapes
... Hard Glass Welds

MOLYBDENUM

... Rod, Sheet, Wire and Special Shapes
... For Grids, Round or Flat
... For Grids, Supports, Heating Elements
... Hard Glass Welds

KULGRID

... For Grids, Round or Flat
... Kulgrid "C" Tungsten Welds

CONTACTS

All Sizes and Shapes For All Applications

... Tungsten - Molybdenum
... Silver and Platinum
... Special Alloys

For High Conductivity
... Precious Metal Laminated
Silver and Platinum on Base Metals

CAL-LUX

FLUORESCENT MATERIALS

— WITH —
Measured Characteristics

... For All Applications

Callite Products

Division of EISLER ELECTRIC CORP.
542 - 39th STREET • UNION CITY, N. J.

CINAUDAGRAPH

Speaker



CINAUDAGRAPH Magic Magnet Speakers

—extensively utilized by all leading radio receiver and P. A. equipment manufacturers—are available in a complete range of sizes from 5½ to 18 inches, to meet your every radio requirement.

If you demand utmost dependability and fidelity of reproduction from your equipment—in-sist on Cinaudagraph P. M. speakers. Carried in stock by all progressive distributors. Free descriptive literature on request.



CINAUDAGRAPH
CORPORATION

Speaker Division • Stamford, Conn.

Do You KNOW Your Antenna?

WITH THE NEW G-R Type 684-A Modulated Oscillator and the Type 516-C Radio-Frequency Bridge the measurement of all of the characteristics of antenna systems is simple.

These two instruments will tell you the following *essential* information about your antenna:

- Antenna resistance*
- Antenna reactance*
- Equivalent inductance and capacitance*
- Presence of guy wires or other conducting structures with natural periods near the operating frequency*
- Presence of high energy losses in poor dielectrics in the antenna system*

In addition with this combination you can:

- Adjust the matching networks to match the antenna and transmitter to the transmission line*
- Adjust the phase shifting networks to obtain the desired phase shift between elements of the antenna array*
- Measure the mutual impedance between the antennas in a directive system*
- Measure the resistance, inductance and capacitance of all of the transmitter networks and their components*

These two instruments, with a simple broadcast receiver, are proving invaluable to a number of broadcast stations in making possible routine measurements of the antenna and station networks. They can help you. Let us show you how.

Type 684-A Modulated Oscillator: \$320.00

Type 516-C Radio-Frequency Bridge: \$225.00

For information address: 30 State Street, Cambridge, Mass.;
or branch offices in New York and Los Angeles

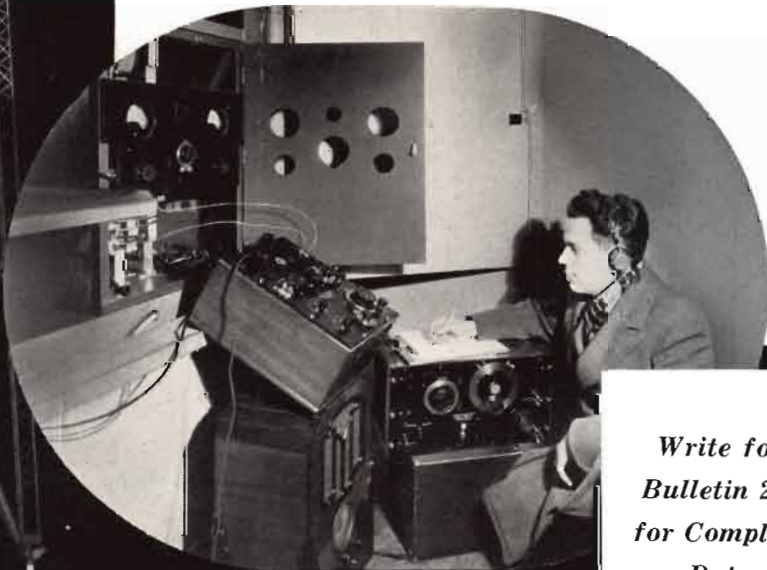

*Write for
Bulletin 234
for Complete
Data*



GENERAL RADIO COMPANY, Cambridge, Mass.

17 YEARS OF RCA PROGRESS

**Boosts Performance,
Cuts Cost of Transmitting Tubes**

Here's Proof!

RCA pioneered the development and sale of transmitting tubes in 1921. Since then, RCA has greatly increased performance capabilities of these tubes, thereby insuring greater sales, which have consistently lowered price levels!

★ 1 9 2 1 ★

These transmitting tubes were developed and sold by RCA.



UV-202
"5 watt"
\$8.00



UV-203
"50 watt"
\$30.00



UV-204
"250 watt"
\$110.00



UV-216—DC Output:
20 watts at 350 volts
\$7.50



UV-217—DC Output:
150 watts at 1000 volt
\$26.50

★ 1 9 3 8 ★

These RCA transmitting tubes give better performance at lower cost.



RCA-809
Plate Input* 75 watts
\$2.50



RCA-805
Plate Input* 315 watts
\$13.50



RCA-833
Plate Input* 1250 watts
\$85.00



RCA-866—DC Output:
550 watts at 2300 volts
\$1.50



RCA-872—DC Output:
2980 watts at 2300 volt
\$14.00

*Class C Telegraph Service

RCA presents the "Magic Key" every Sunday, 2 to 3 p. m., E. S. T., on the NBC Blue Network



Radiotrons

RCA MANUFACTURING CO., INC., CAMDEN, NEW JERSEY

A Service of the Radio Corporation of America

FIRST IN METAL
FOREMOST IN GLASS
FINEST IN PERFORMANCE