



*Since 1949 Devoted to
Engineering, Manufacturing
and Servicing Equipment
for the Broadcast, Television
Electronic Industry*

General Offices & Plant
N. J. HIGHWAY 33 / MANALAPAN TOWNSHIP / NEW JERSEY
P. O. BOX 677, FREEHOLD, N. J. 07728

58K

58K 147

INSTRUCTION BOOK
STANDARD ELECTRONICS

TYP 130 F.M. MULTIPLEX TRANSMITTER

MANUFACTURED BY

STANDARD ELECTRONICS CORPORATION
P.O.Box, 677, Freehold, N.J.
07728

December 1969



124,889 KC
X 864
124.9

1/2 sec 2nd Harmonic
Stage on FM
SECRET
6-30-44
130000000

TABLE OF CONTENTS

Para.		Page
	<i>XTAL FREQ - 102/125 - 88/108</i>	
SECTION 1 - DESCRIPTION		
1-1.	General.	1-1
1-3.	Reference Data	1-1
1-5.	Physical Characteristics	1-2
1-7.	Tube and Rectifier Complement.	1-2
1-8.	Description.	1-3
1-9.	Equipment Supplied	1-3
SECTION 2 - INITIAL OPERATION		
2-1.	General.	2-1
2-3.	Preliminary.	2-1
2-5.	Initial Operation.	2-1, 2-2, 2-3
SECTION 3 - OPERATION		
3-1.	General.	3-1
3-3.	Normal Operation	3-1
3-4.	Procedure.	3-1
3-6.	Logging Log.	3-2
		3-3 XTAL
SECTION 4 - THEORY OF OPERATION		
4-1.	General.	4-1
4-3.	Circuit Description.	4-1
4-5.	S-1786 FM Modulation (Serrasoid)	4-1
4-7.	S-1787 Frequency Multiplier.	4-3
4-9.	S-1788 250W Power Amplifier.	4-3

SECTION 2

SECTION 3

SECTION 4

SE

SECTION 5

SECTION 6

SECTION 7

SECTION 8

SECTION 9

SECTION 4 - THEORY OF OPERATION

	Page
4-11. S-1791 L.V. Power Supply.	4-5
4-13. S-1792 H.V. Power Supply.	4-5

SECTION 5-MAINTENANCE

5-1. General.	5-1
5-3. Maintenance.	5-1
5-5. Trouble Shooting	5-1

SECTION 6 - PARTS LIST

Paragraph

6-1. General	6-1
------------------------	-----

. LIST OF ILLUSTRATIONS

Figure No.	Page
1-1. Type 930 F.M. Multiplex Transmitter	1-0
4-1. Type 930 F.M. Multiplex Transmitter, Block Diagram.	4-0
4-2. S-1788 250W Power Amplifier, simplified schematic	4-4
5-1. Type 930 F.M. Multiplex Transmitter, front view	5-2
5-2. Type 930 Multiplex Transmitter, rear view.	5-3
5-3. Across line schematic diagram, Type 930 - F.M. Multiplex Transmitter.	5-4
5-4. Driver frame schematic diagram, Type 930 F.M. - Multiplex Transmitter	5-5
5-5. S-1786 F.M. Modulator Panel (Serrasoid) - schematic diagram	5-6
5-6. S-1787 Frequency Multiplier, schematic diagram.	5-7
5-7. S-1788 250W Power Amplifier, schematic diagram.	5-8
5-8. S-1781 Low Voltage Power Supply, schematic diagram.	5-9
5-9. S-1792 High Voltage Power Supply, schematic diagram	5-10

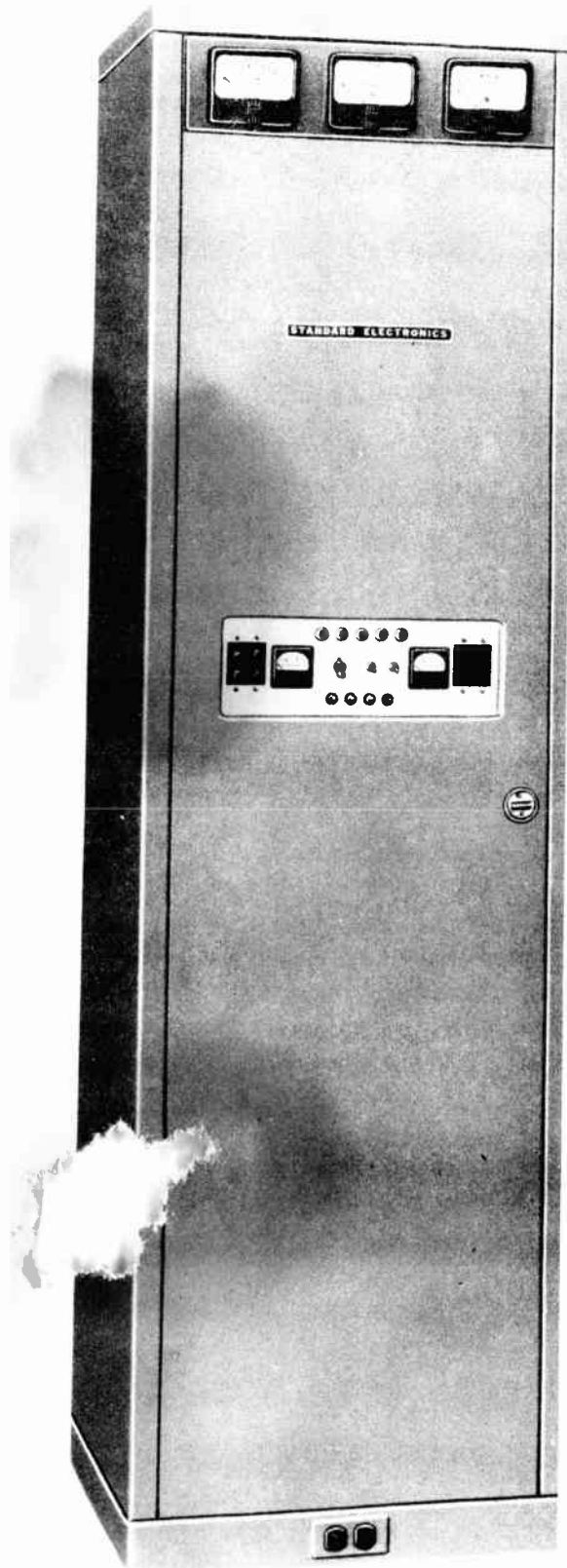

Figure 1-1 Type 930 F.M. Multiplex Transmitter

SECTION 1

DESCRIPTION

1-1. GENERAL

1-2. The Standard Electronics F.M. Multiplex Transmitter Type 930 delivers a standard frequency modulated R-F Signal and meets or exceeds applicable F.C.C. & E.I.A. standards. The output of the transmitter may be fed directly into a suitable Antenna or a higher power standard Electronics Amplifier.

1-3. REFERENCE DATA.

1-4. Table 1-1 gives data for quick reference.

Table 1-1. Type 930 F.M. Multiplex Transmitter
Reference Data

Input Voltage	208/230V 50/60 cps 1 phase 115 V.A.C.
Total Power Requirements	Approx. 1.3 KVA at 90% pf.
Power Output	250W FM
Efficiency	64%
Frequency Range	88-108 mc.
RF Output Impedance	50/51.5 ohms
A.F. Input Impedance	600/150 ohms Bal. or Unbal.
Frequency Response	Within \pm 1 db. of 75 microsecond preemphasis curve
Frequency Stability	\pm 1000 cps.
Modulation Capability	\pm 100 KC.
Input Level for Main Channel 100% Modulation	\pm 10 dbm.
FM Carrier Noise Level	At least 65 db. below 100% modulation.
Harmonic distortion	Less than 1% from 50 to 15,000 cps.
Crosstalk Subcarrier, into Main Carrier	Better than 65 db.

SUB-CARRIER CHANNEL

Frequency Range	25 to 75 KC.
Input Impedance	75/600 ohms Bal. or Unbal.
Input Level	0 dbm for 50% modulation of main carrier.
Gain Response	21 db \pm 1 db.
Harmonic distortion	Less than 1% between 25 and 75 KC.
Crosstalk Main Channel into Subcarrier	Better than 50 db.

1-5. **PHYSICAL CHARACTERISTICS**

1-6. The size and weight of a complete equipment are listed in table 1-2.

Table 1-2. Type 930 F. M. Multiplex Transmitter
Physical Characteristics

Depth	Width	Height	Weight
22"	24"	84"	450 lb

Door Swings

Front	Back
21"	21"

Exhaust Air Flow Approx. 100 cfm.

1-7. **Tube and Rectifier Compliment.**

<u>TYPE</u>	<u>QUANTITY</u>
12AT7	4
12AT7/EC81	1
12AX7	1
6AS6	1
6AU6	7
6AH6	2
5686	1
OC3/VR105	1
OD3/VR150	1
6C4	2
6360	1
2E26 <i>power out?</i>	1
4X250B <i>power in 3</i>	1
0A2	1
0B2	1

RECTIFIERS

<u>TYPE</u>	<u>QUANTITY</u>
F6	50

1-8. **DESCRIPTION:**

The transmitter with its silicon diode power supply is housed in a single cabinet, with front and rear access doors. Looking at the front, see Figure 5-1, the lower two panels contain all the necessary power supplies.

The unit directly above is the F. M. Modulator panel incorporating the Serrasoid principal. It comes equipped with two inputs; one for regular service and one for multiplex service.

The centrally located unit, which is also accessible with the front door closed, is the main control panel. This panel contains all the main control functions of the transmitter including the main breakers, control lights, filament voltage control, sub-metering, fuses, etc.

Directly above the control panel is the frequency multiplier stage. Its function is to bring output frequency of the modulator up to carrier frequency.

Directly above the multiplier unit is the final output amplifier, housed, next to it, is the screen regulator and blower for the final tube.

1-9. **EQUIPMENT SUPPLIED**

1-10. The units comprising a complete equipment are listed in table 1-3. See Figure 5-1.

Table 1-3. Type 930 Transmitter
Equipment Supplied

<u>UNIT</u>	<u>TITLE</u>
S-1789	Cabinet
S-1792	H.V. Power Supply
S-1791	L.V. Power Supply
S-1790	Control Panel
S-1786	F.M. Modulator Panel
S-1787	Frequency Multiplier
S-1788	250W Power Amplifier
S-1799	Meter Panel

SECTION 2

INITIAL OPERATION

2-1. GENERAL

2-2. The following procedure is given for initial operation.

2-3. PRELIMINARY

2-4. Prior to initial operation, check the following:

- A. Make sure all tubes are seated properly in their sockets and, where required, plate connections are tight.
- B. Check to see that the following protective panels are in place and secured and high voltage shorting switches are functioning.
 - 1. High voltage power supply rear panel, which operates S501. See Figure 5-2 and 5-9.
 - 2. Frequency multiplier rear panel which operates S201. See Figure 5-2 and 5-6.
 - 3. 250W Power Amplifier rear panel, which operates S603. See Figure 5-2 and 5-7.

2-5. INITIAL OPERATION

CAUTION

PA Overload Breaker S404 should be kept in the off position until just prior to tuning.

- a. Connect a 208/230 Volt 60 cps single phase source, and a 115 Volt 60 cps single phase to the appropriate leads in the junction box which is located halfway up on the left rear of the transmitter frame. See Figure 5-2 and 5-3.
- b. Ground the transmitter frame to the system ground.
- c. Terminate the transmitter in a dummy load or the antenna by connecting to the output of the power monitor Z901. See Figure 5-2.
- d. Energize the A.C. Power Breaker S401 on the control panel. See Figure 5-1. Adjust line voltage corrector T401 AC CONTROL to read 230V on meter M402 AC VOLTS.

- e. Throw FILAMENT ON-OFF switch S402 to ON position and check to see that FIL ON indicator I402 is lit. Re-adjust line voltage corrector T401 AC CONTROL for 230V on meter M402 AC VOLTS.
- f. After 60 seconds, HV READY indicator I403 will come on indicating all door interlocks are actuated and the transmitter is ready for application of high voltage.
- g. With the PA OVERLOAD breaker S404 in the off position, throw PLATE VOLTAGE ON-OFF switch S403 to the ON position. This energizes the low voltage power supply which furnishes d-c power to the F. M. Modulator panel and the Frequency Multiplier panel only.
- h. Turn METER SELECTOR S405 to MOD position and METER SWITCH S1 on the FM Modulator Panel (Serrasoid) S-1786, see Figure 5-1 and 5-5, to position 11 and adjust C97 AMPL PLATE TUNING; also on the Modulator Panel, for maximum reading on TUNING METER M401 on the control panel.
- i. Turn METER SELECTOR S405 to V201 Ig. position and adjust Z201 on the Frequency Multiplier Panel S-1787 for maximum reading on TUNING METER M401.
- j. Turn METER SELECTOR S405 to V202 Ig. position and adjust Z202 on the Frequency Multiplier Panel for maximum on TUNING METER M401.
- k. Turn METER SELECTOR S405 to V203 Ig. position and adjust Z203 for maximum reading on TUNING METER M401.
- l. Turn METER SELECTOR S405 to V204 Ig. position and adjust Z204 and Z205 for maximum reading on TUNING METER M401.
- m. Turn METER SELECTOR S405 to V601 Ig. position and turn the R. F. Output Control R401 on the control panel for a slight indication on the TUNING METER M401, then adjust Z206 and Z207 for maximum indication on the TUNING METER.
- n. Turn R. F. OUTPUT control R401 to minimum position and turn PLATE VOLTAGE ON-OFF switch S403 to OFF.

Begin here

- V601 IG*
- o. Energize PA OVERLOAD breaker S404, turn PLATE VOLTAGE ON-OFF switch S403 to ON, KILOVOLTS PLATE METER M802, See Figure 5-1, should read approximately 1700V dc and HV ON indicator I404 is ON.
 - p. Turn R. F. OUTPUT control R401 approximately one quarter turn and re-adjust Z206 and Z207 for maximum indication on TUNING METER M401.
 - q. Turn GRID TUNING C601 on the Power Amplifier panel S-1788, See Figure 5-1, for maximum on the TUNING METER M401.
 - r. Turn METER SELECTOR switch to position V601 ISCR.
 - s. Adjust C603 LOADING, C602 PLATE TUNING and RF OUTPUT control R401 for 250W as read on WATTS RF OUTPUT meter M803 with 230 ma. as indicated on MILLIAMPERES PLATE meter M801, while doing this, note TUNING METER M401 reading which should be .7, if the screen current is too high, increase LOADING and if too low, decrease LOADING and then retune PLATE TUNING control after each loading adjustment.

NOTE:

The multiplier factor for the grid and screen current of the final tube is "30" IE. .7 on the tuning meter X 30=21 ma. screen current. .18 on the tuning meter X 30=5.4 ma. Grid Current.

SECTION 3

OPERATION

- 3-1. GENERAL
- 3-2. Normal operating procedures for the Type 930 F. M. Multiplex Transmitter are given in this section. Make sure that all of the procedures outlined in SECTION 2 have been performed.
- 3-3. NORMAL OPERATION
- a. Energize the AC POWER breaker.
 - b. Adjust line voltage with AC CONTROL to read 230V on AC VOLTS METER.
 - c. Throw FILAMENT ON-OFF switch to ON. Check to see that FIL ON indicator is ON.
 - d. Re-adjust line voltage with AC CONTROL for 230V.
 - e. After 60 seconds HV READY indicator will come on.
 - f. With PA OVERLOAD breaker in the ON position, throw PLATE VOLTAGE ON-OFF switch ON.
 - g. KILOVOLTS PLATE meter should read approx. 1700V dc. MILLIAMPERES PLATE meter should read approx. 230 MA and WATTS RF OUTPUT 250.

CAUTION

Never energize the PA OVERLOAD breaker without the transmitter being connected to the antenna or a dummy load.

- 3-4. SHUT-DOWN PROCEDURE
- 3-5. When shutting down the transmitter proceed as follows:
- a. Throw PLATE VOLTAGE ON-OFF switch to OFF, FILAMENT ON-OFF switch to OFF.
 - b. After 5 minutes, throw A.C. POWER Breaker to OFF.

- 3-6. OPERATING LOG
- 3-7. As required by the F.C.C., keep an operating log in which is recorded periodic meter readings. This will aid in preventive maintenance, as a large change in meter readings over short periods of time may indicate a faulty component.
- 3-8. Table 3-1 lists indication lights and their condition during normal operation.

TABLE 3-1
TYPE 930 F.M. TRANSMITTER
Indicator Lights

<u>NOMENCLATURE</u>	<u>NORMAL INDICATION</u>
PWR ON	ON
FIL ON	ON
HV READY	ON
HV ON	ON
OVEN ON	Intermittent ON OFF

- 3-9. Table 3-2 lists typical meter readings.

TABLE 3-2

<u>METER SELECTOR</u> switch S405	<u>METER SWITCH S1</u> positions	<u>TUNING METER M401</u> readings
MOD	1	80
MOD	2	45
MOD	3	85
MOD	4	70
MOD	5	50
MOD	6	40
MOD	7	60
MOD	8	20
MOD	9	65
MOD	10	15
MOD	11	30
MOD	12	not used
V201IG		15
V202IG		45
V203IG		75
V204IG		50
V601IG		18
V601ISCR		52

<u>METER</u>	<u>READING</u>
KILOVOLTS PLATE M802	1700V
MILLIAMPERES PLATE M801	230 MA
WATTS RF OUTPUT M803	250 W

This is done by a small metal tab (CN TAB, see Figure 4-2) which is mounted adjacent to the plate of the 4X250B V601 and connected to the bottom of L613 for proper phasing,

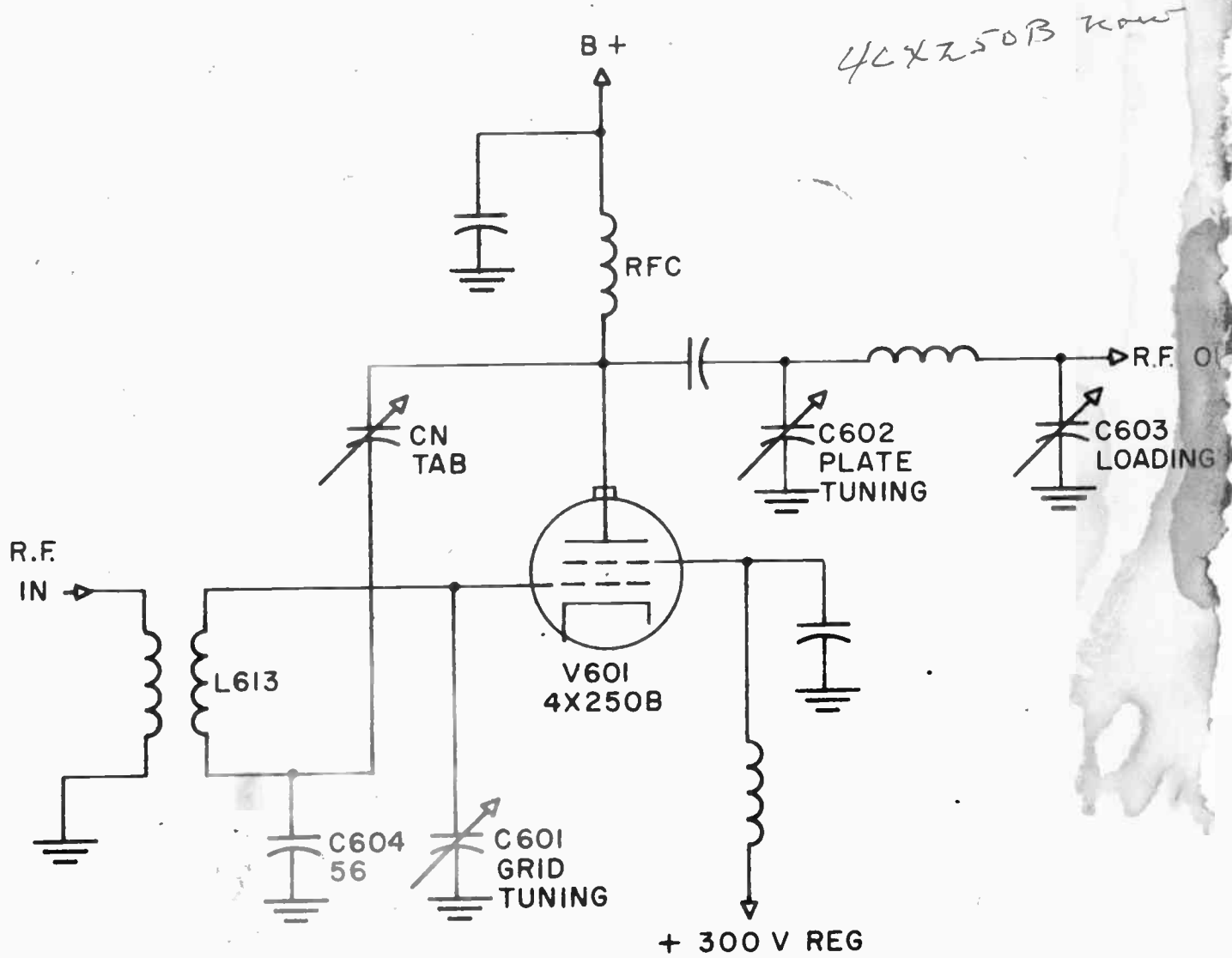

FIGURE 4-2 S-1788 250W POWER AMPLIFIER, SIMPLIFIED SCHEMATIC

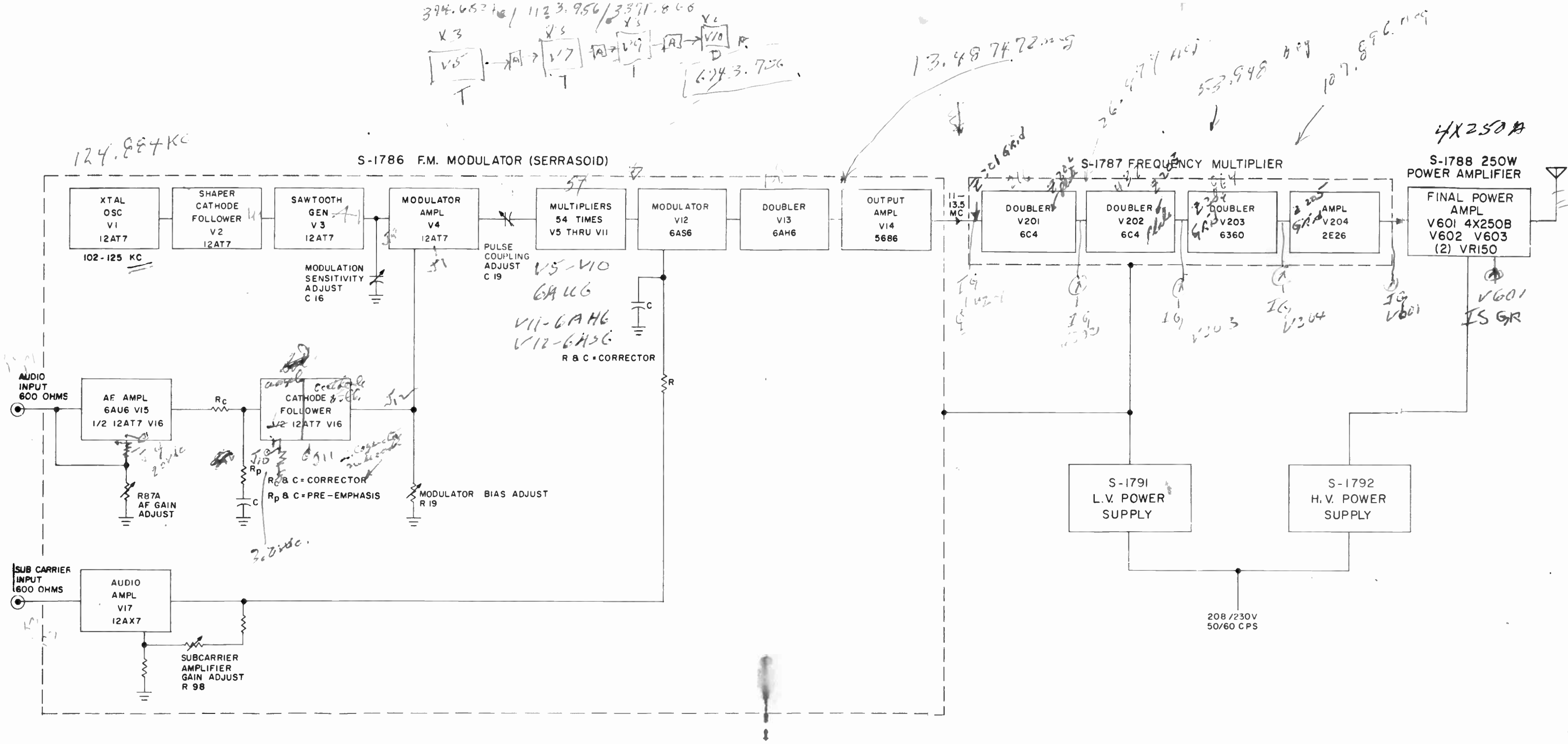

Figure 4-1 Type 930 F.M. Multiplex Transmitter, Block Diagram

33

SECTION 4

THEORY OF OPERATION

4-1. GENERAL

4-2. The Type 930 F. M. Multiplex Transmitter delivers a standard frequency modulated R. F. output signal of 250 watts throughout the 88-108 mcs. F. M. Band.

4-3. CIRCUIT DESCRIPTION

4-4. The Type 930 F. M. Multiplex Transmitter may be divided into three sections exclusive of the power supplies. See block diagram Figure 4-1.

4-5. S-1786 F. M. MODULATOR (SERRASOID).

4-6. The Serrasoid, see Figure 5-5 and 4-1, circuit has been developed to provide a reliable, low distortion, low noise and excellent linear frequency response modulation system for F. M. broadcast application, in addition, it also enables direct crystal control of the center frequency of the station.

The modulator is designed around four receiving-type tubes, V1 thru V4 (12AT7's). The quartz crystal Y1 in conjunction with the first 12AT7 V1 generates an R. F. signal at the crystal frequency. This frequency may range from 102 to 125 kc, depending upon the authorized frequency of the station.

The second tube, V2, shapes the oscillator buffer output to produce a steeply rising waveform at the crystal frequency, while the third tube, V3, is a driven sawtooth generator with a bootstrap circuit to ensure linear rise of the generated waveform. The linear sawtooth wave thus generated at a recurring rate of approximately 100 kc, is applied to the grid of V4 and the modulation bias potentiometer R19 is adjusted to a point where the grid bias, created by the plate current is such that conduction occurs when the sawtooth applied is about 50 per cent on its way up. Upon conduction, the balance of the sawtooth is clipped and at the very instant the tube conducts, a negative pulse is observed on its plate. This is the most important event of the process, for it is by this means that the linear sawtooth can be utilized to produce a phase modulated or frequency modulated signal.

If the cathode bias resistor on the right half of V4 is varied, it is easily shown on an oscilloscope that the negative pulse formed on the plate at time of tube conduction will vary its position either sooner or later in reference to the starting of the sawtooth. In other words, a conduction point lower or higher on the slope of the sawtooth causes the plate pulse to be formed in time position either sooner or later. If, instead of varying the conduction point by adjustment of the cathode potentiometer, an audio voltage was applied at this point, the plate pulses would be positioned by the audio voltage super-imposed upon the cathode. At this time, a system of pulse-position modulation has been developed by the audio wave, the plate pulses are phase-modulated by the audio voltage determining the instantaneous conduction point of the tube.

The amount of phase shift possible with this circuit is in the order of plus and minus 150° . In actual application, only 90° of plus or minus $1\frac{1}{2}$ radians is used on the basis of producing 100% modulation at the output frequency after multiplication.

Prior to its application on the cathode of the modulator V4, the audio signal is passed through a corrector network, RC and C, and a preemphasis network RP and C. The corrector network compensates for the tendency of the high audio frequencies to produce more equivalent frequency modulation than the low audio frequencies. The preemphasis network is used in this transmitter with a corresponding deemphasis network in the FM receiver. The purpose here is to raise the level of the high audio frequencies to such a degree that they will over-ride noise. That is, to produce a better signal-to-noise ratio at the receiver.

A second input is provided on the modulator panel by means of which a multiplexed signal can be introduced. A subcarrier generator outside the transmitter under discussion generates a carrier in the frequency range of 25 to 75 kc. The modulation of the subcarrier is FM. The subcarrier is amplified by V17 and applied to the main carrier channel in the form of phase modulation. The phase modulation of the main carrier at V12 is accomplished by the combination of two quadrature voltages at the output of V11 and V12. The grids of these tubes are driven by RF signals that are approximately 90° apart. They combine to form a resulting vector at their common plate load. When subcarrier modulation is applied to the grid of V17, the gain of this tube varies and its output amplitude changes. This new vector which varies in amplitude above and below a static level combines with the fixed amplitude and thus produces phase modulation.

The rate and amount of phase modulation is proportional to the multiplex subcarrier frequency and amplitude. When the multiplexing feature of this modulator panel is used, the modulation level of the main channel must be reduced so that the combined modulation of the main program input and the subcarrier input will not produce a total FM deviation greater than 75 kc.

Total frequency multiplication on the modulator panel is 108. The frequency range at the output of this panel is 11 to 13.5 Mc. The available power from the final amplifier stage, V14 (Type 5686), is approximately 1 watt into 50 ohms.

4-7. S-1787 FREQUENCY MULTIPLIER

4-8. The total frequency multiplication of the F. M. modulator panel is 108. A further multiplication of 8 takes place on the frequency-multiplier panel, See Diagram 5-6. Three doubler stages V201, V202, and V203, and an output amplifier V204, a 2E26 complete the panel. A potentiometer, R401 RF CONTROL, which is mounted on the control panel varies the screen voltage of the 2E26 V204 to permit the operator to change the drive to the power amplifier, which in turn varies the output power of the transmitter. Between V202 and V203 an over coupled type of coupling circuit is provided to increase the band width capabilities of the frequency multiplier. The input impedance of the frequency multiplier panel is 50 ohms. This feature permits inserting a power monitoring device between panels and checking RF power.

4-9. S-1788 250W Power Amplifier

4-10. The power amplifier utilizes a single 4 X 250B V601, See Figure 4-2, 5-7, operating as a conventional class C amplifier. Two VR150 voltage regulator tubes V602 and V603 connected in series furnish regulated screen voltage for V601.

Neutralization is accomplished by a small amount of capacitive coupling CN TAB which connects the input or grid circuit to the output or plate circuit in such a way that current passing through CN is of the proper amplitude and phase to neutralize exactly the transfer of energy between the input and output circuits of the amplifier via the grid-plate tube capacitance.

This is done by a small metal tab (CN TAB, see Figure 4-2) which is mounted adjacent to the plate of the 4X250B V601 and connected to the bottom of L613 for proper phasing.

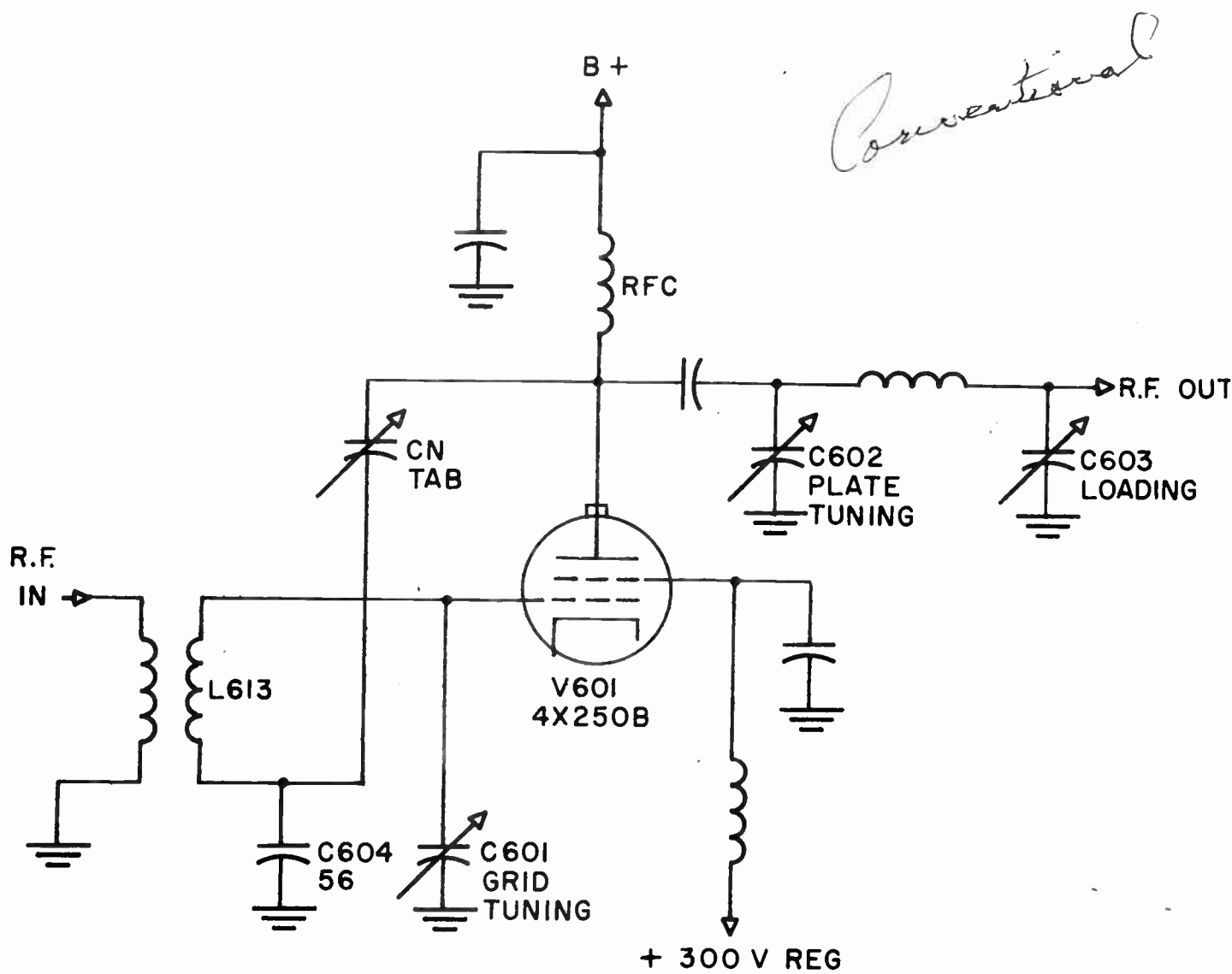

FIGURE 4-2 S-1788 250 W POWER AMPLIFIER, SIMPLIFIED SCHEMATIC

J602 RF OUTPUT and J603 MONITOR connectors are mounted on the front panel of the power amplifier. J602 is connected to the power monitor Z901, See Figure 5-2, by a length of coaxial cable and the antenna or dummy load is connected to the output of the power monitor.

The power monitor and its associated meter WATTS RF OUTPUT M803 is utilized by the operator to measure both incident (forward power) and reflected power. Switching from forward to reflected power is done by the RF WATTMETER DIRECT REFLECTED switch S406, See Figure 5-1 and 5-4, which is mounted on the control panel S-1790. Potentiometer R410 CALIBRATE is provided so that the power meter may be calibrated. This is done by using a dummy load with an associated power meter.

When the power meter readings are inserted in the following formula, the SWR toward the load may be determined.

$$SWR = \frac{1 + \sqrt{\frac{P_R}{P_D}}}{1 - \sqrt{\frac{P_R}{P_D}}}$$

approx 1.05:1 normally

WHEN: P_R = power in watts REFLECTED

P_D = power in watts DIRECT

4-11. S-1791 L.V. Power Supply

4-12. The low voltage power supply, See Figure 5-8, contains the step-down transformer T304, which provides 6.3V for the crystal oven, a full-wave rectifier using silicon diodes CR307, CR308 with T302 which furnishes 6.3V dc at 1 amp for V15, V16 and V17 heaters in the FM Modulator. All the unregulated and regulated DC Voltages for the FM modulator are furnished by T301 with Silicon diodes CR301 through CR306 in a series full-wave configuration, regulation is accomplished by the use of V301 OA2 and V302 OB2 connected in series. T302 also furnishes AC filament power for the FM modulator and the frequency multiplier. T303 supplies filament power for the 4X250B, V601 power amplifier. Included in the low voltage power supply is the time delay relay K301, which is a 60 second thermal time delay relay. This relay prevents the application of plate power until all tubes have reached their operating temperature.

Conventional

4-13. S-1752 H.V. Power Supply

4-14. The high voltage power supply, see Figure 5-9, furnishes 1900V \pm 10% at 300 ma. through the use of T501 and silicon diodes CR501 - CR540 connected in a single phase full-wave bridge arrangement.

A bias supply is incorporated within this unit which utilizes T502, silicon diodes CR541 and CR542 connected in a conventional single phase full-wave center tapped circuit. Bias for the 4 X 250B V601 in the final amplifier is obtained from the -90 volt at 35 ma. tap. V201 through V204 bias voltages in the frequency multiplier are obtained from the -20 Volt at 13 ma. tap.

A safety circuit in the transmitter makes use of the -100 volt output of the bias supply, which prevents the application of plate voltage to the final amplifier.

The -100 volts from the power supply is fed through pins 3 and 7 of V602 and V603, VR150's and interlock S601 on the power amplifier, See Figure 6-2, then through rear door switch S901, remote interlock TB907, and then to the coil of bias relay K402. Bias voltage must be available and all interlocks closed for K402 to close to permit application of plate power.

Handwritten calculations:

$$\frac{90}{.035} = 90.000A$$

$$\frac{90}{.035} = 2700$$

$$2700 \times .0125 = 337.5 \text{ watts}$$

SECTION 5

MAINTENANCE

5-1. GENERAL

5-2. This section contains information, photographs and schematics to aid in maintenance and trouble shooting of the equipment.

5-3. MAINTENANCE

5-4. If maintenance is to be performed on the transmitter, it must be shut down. Follow the procedure for shutting down as outlined in Paragraph 3-4.

There are no lubrication requirements for this equipment. The air filter supplied is one of the washable type and should be reverse flushed with water and detergent. The thin dry type filter element should be re-installed after washing and drying.

*except SAE 30
for blower
motor every
6 months.*

5-5. TROUBLE SHOOTING

5-6. The following illustrations are supplied to facilitate the operator in locating trouble within the equipment.

ILLUSTRATIONS

Figure No.		Page
5-1.	Type 930 F.M. Multiplex Transmitter - front view	
5-2.	Type 930 F.M. Multiplex Transmitter - rear view	
5-3.	Across the line schematic diagram, Type 930 F.M. Multiplex Transmitter	
5-4.	Driver frame schematic diagram, Type 930 F.M. Multiplex Transmitter	
5-5.	S-1786 F.M. Modulator Panel (Serrasoid) - schematic diagram	
5-6.	S-1787 Frequency Multiplier, schematic diagram	
5-7.	S-1788 250W Power Amplifier, schematic diagram	
5-8.	S-1781 Low Voltage Power Supply, schematic diagram	
5-9.	S-1782 High Voltage Power Supply, schematic diagram	

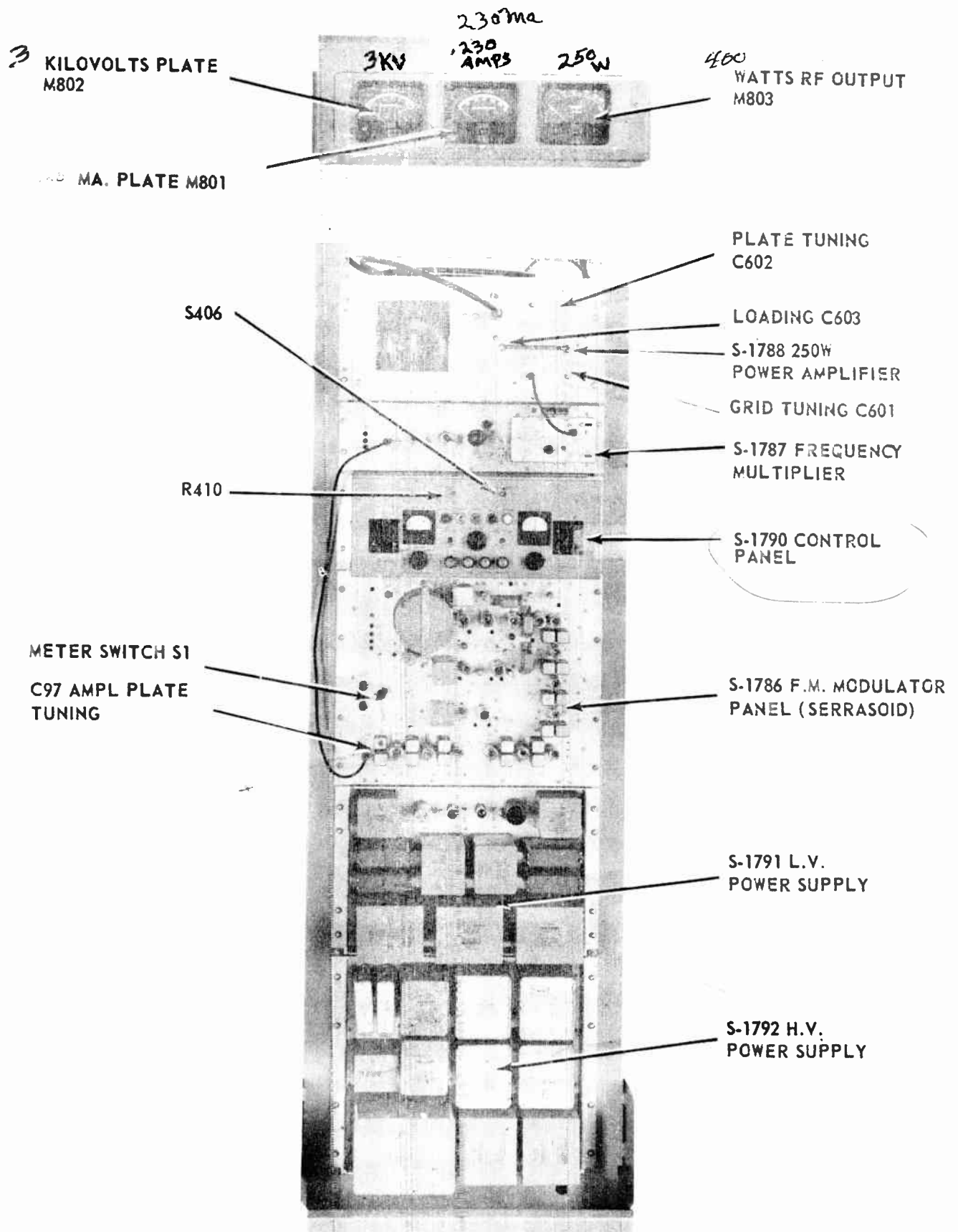

Figure 5-1 Type 930 F.M. Multiplex Transmitter, front view

POWER MONITOR
Z901

S601

S603

S201

INPUT POWER

S501

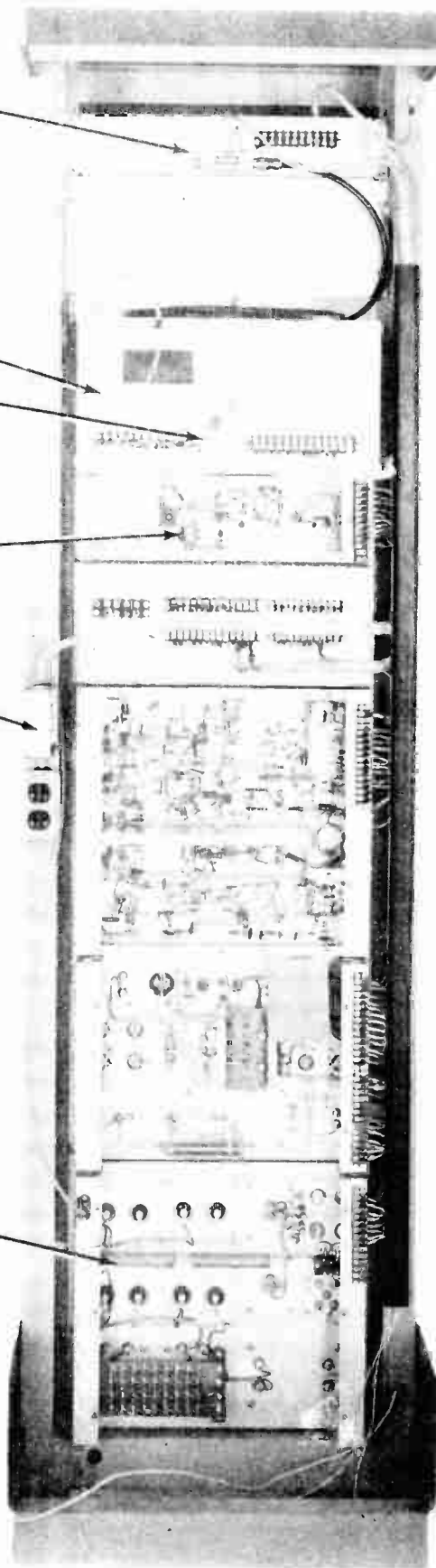

Figure 5-2 Type 930 F.M. Multiplex Transmitter, rear view

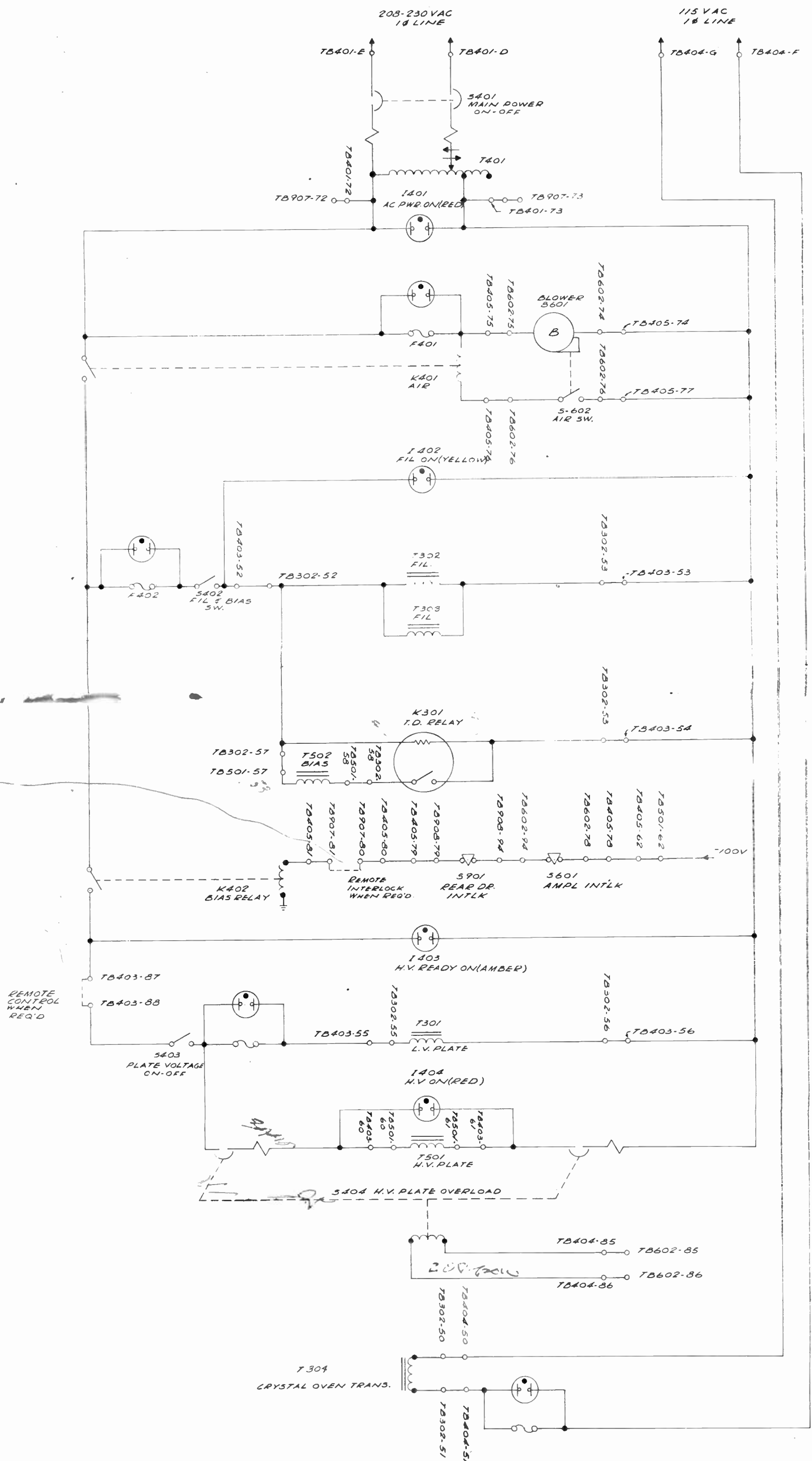

Figure 5-3 Across the line schematic diagram, Type 930 F.M. Multiplex Transmitter

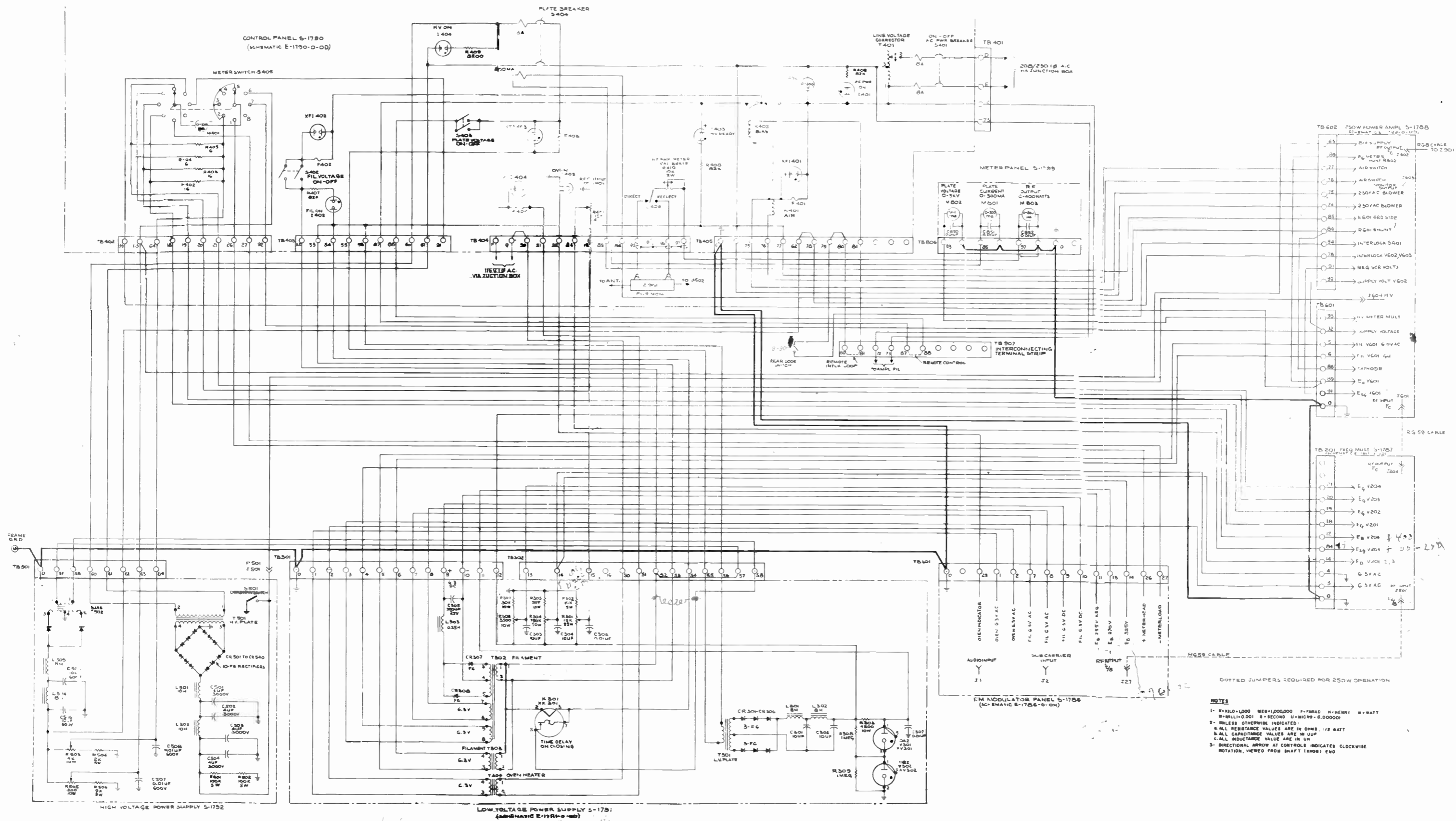

Figure 5-4 Driver frame schematic diagram, Type 930 F. M. Multiplex Transmitter

*Not Right
in circuit
for Ser*

PHASE MOD
6AS6
V12
XV12

AMPLIFIER (3)
6AH6
V11
XV11

DOUBLER (1)
6AU6
V10
XV10

TRIPLER (3)
6AU6
V9
XV9

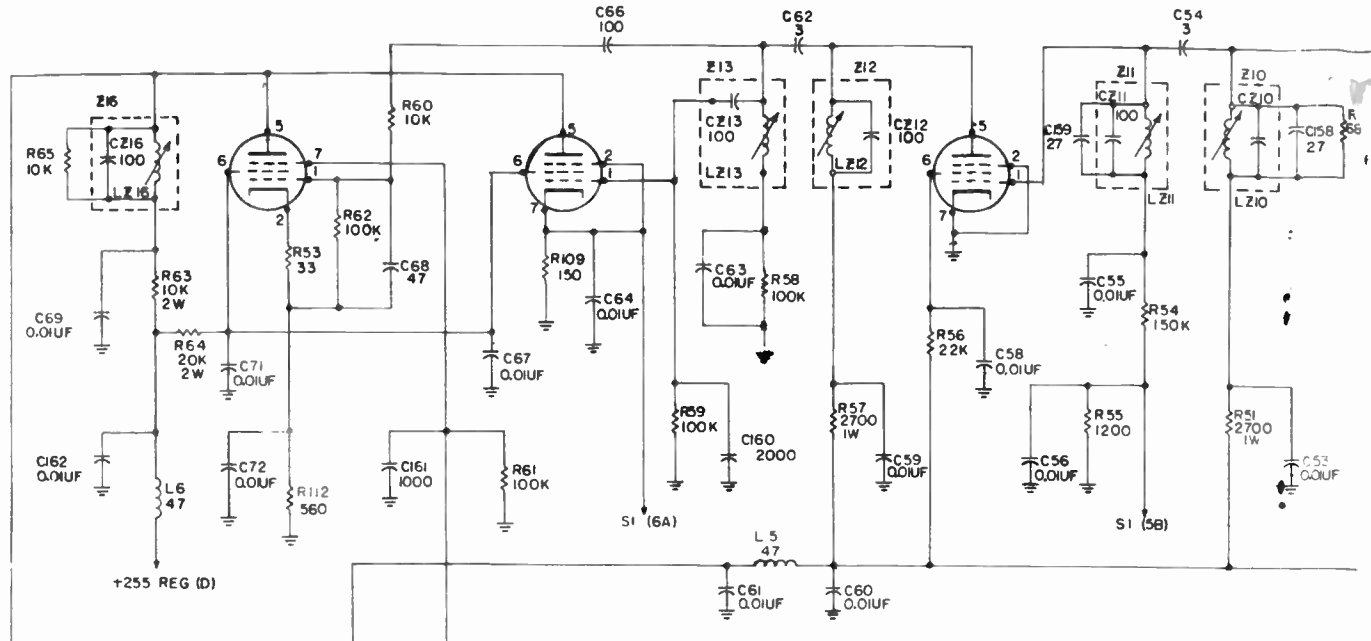

DOUBLER (2)
6AH6
V13
XV13

OUTPUT
56
V
X

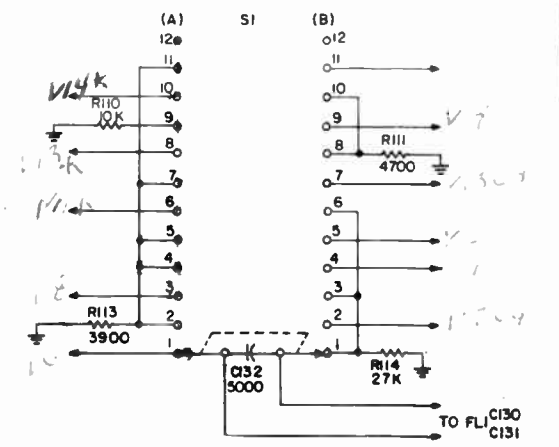
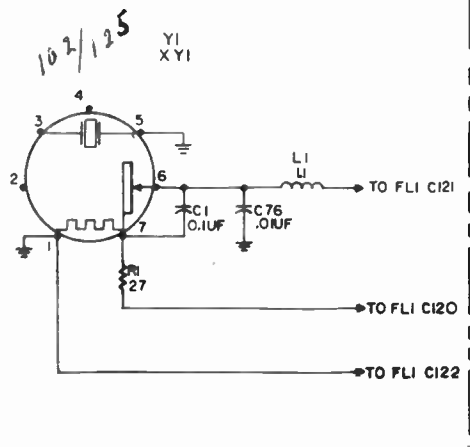
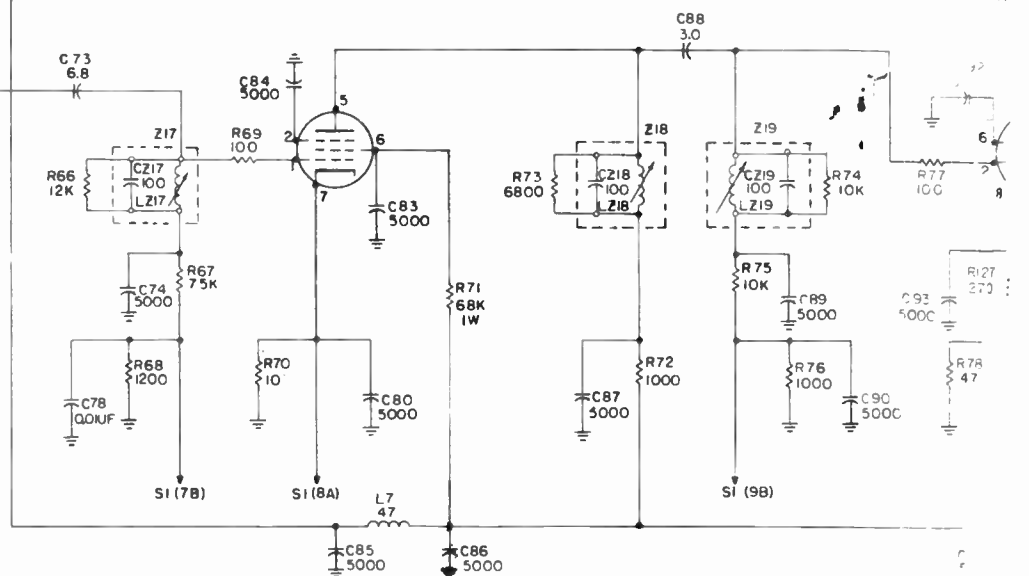

HAL

2.5 11/11

AMPLIFIER (2)
6AU6
V8
XV8

TRIPLER (2)
6AU6
V7
XV7

AMPLIFIER (1)
6AU6
V6
XV6

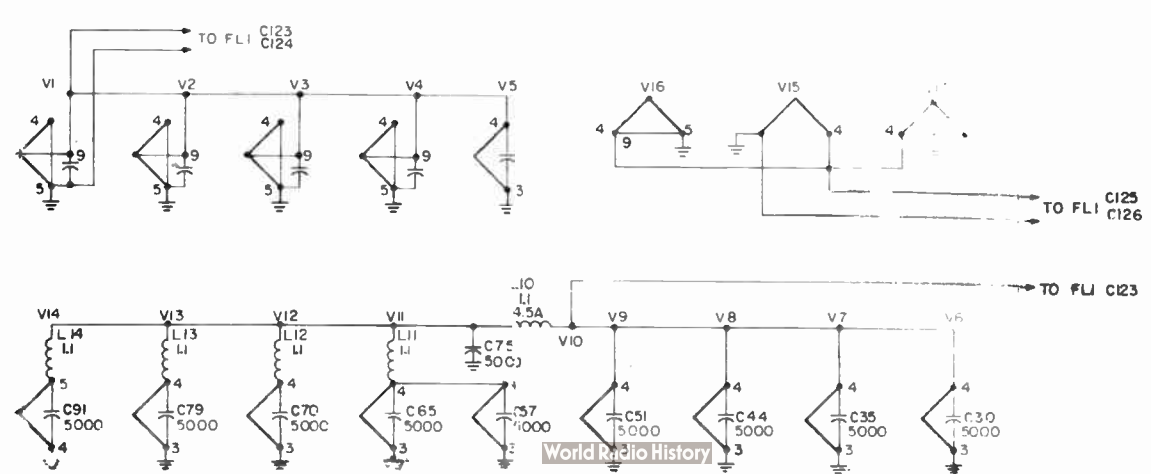
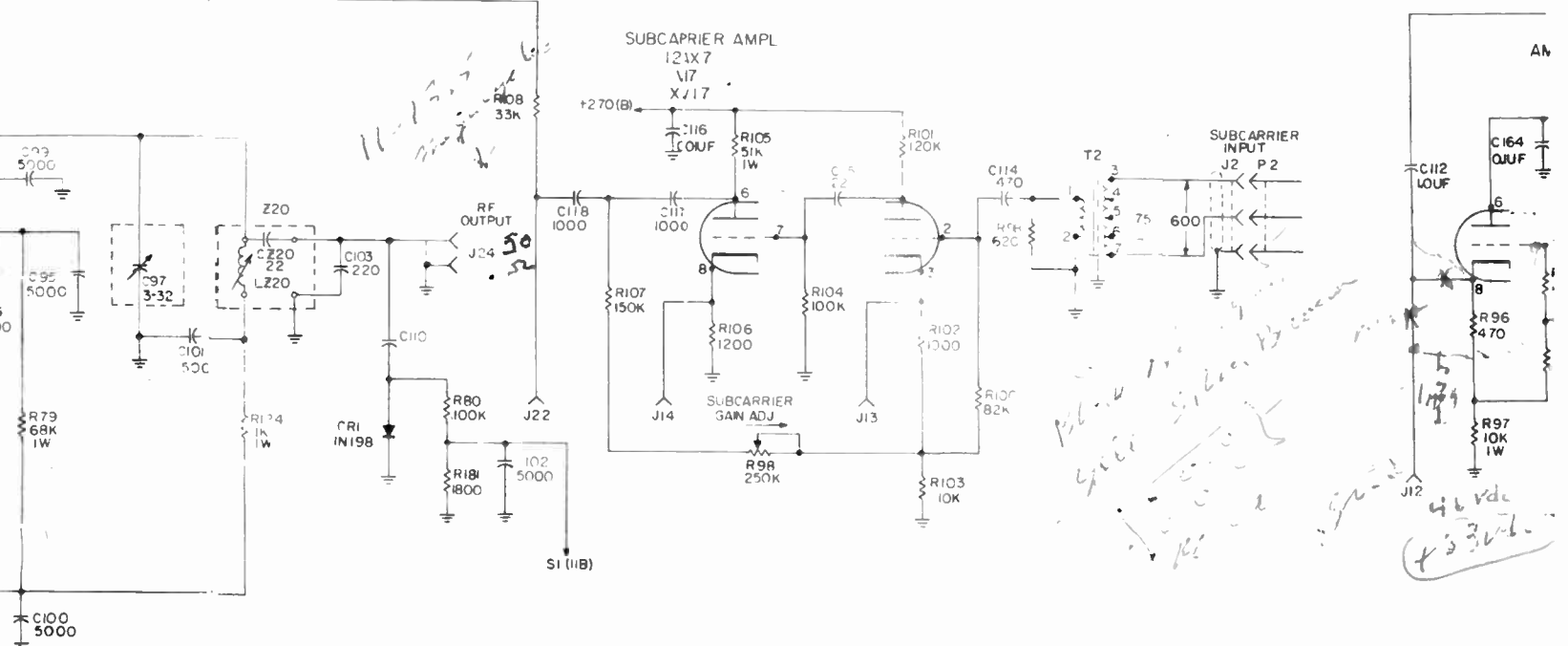
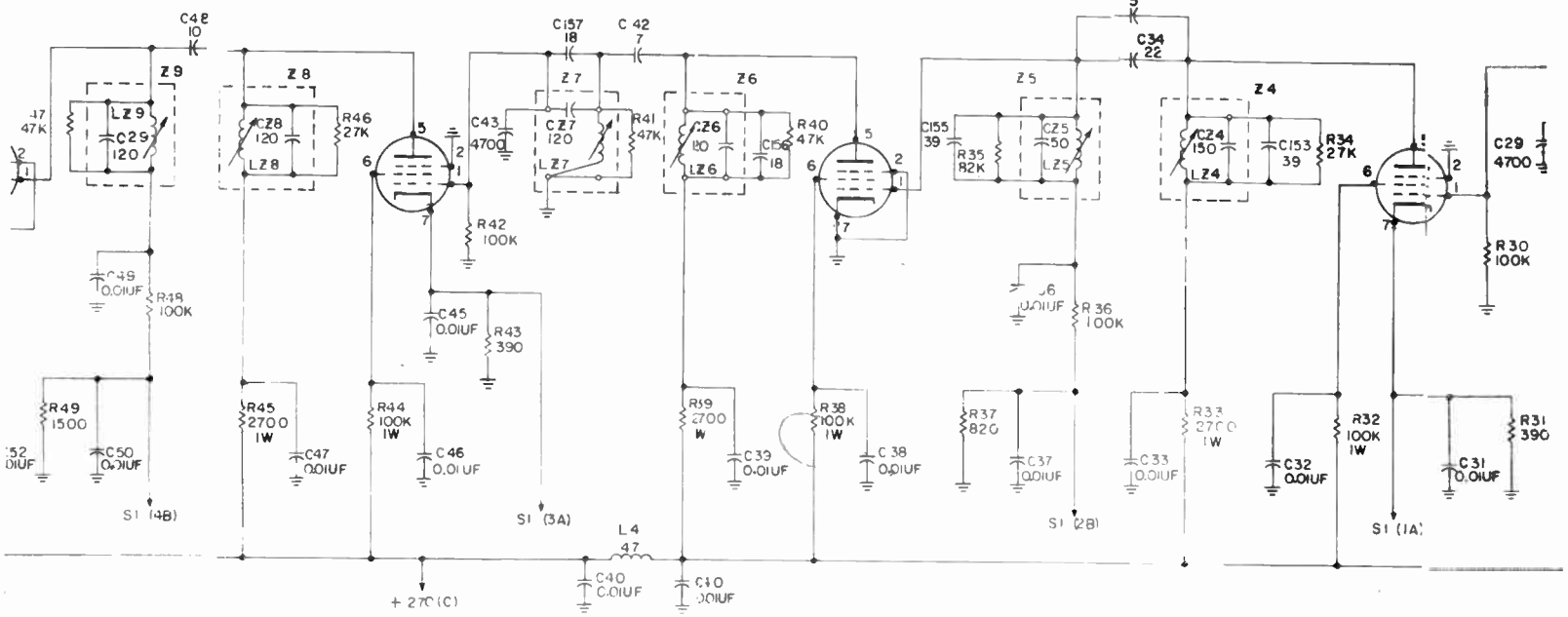

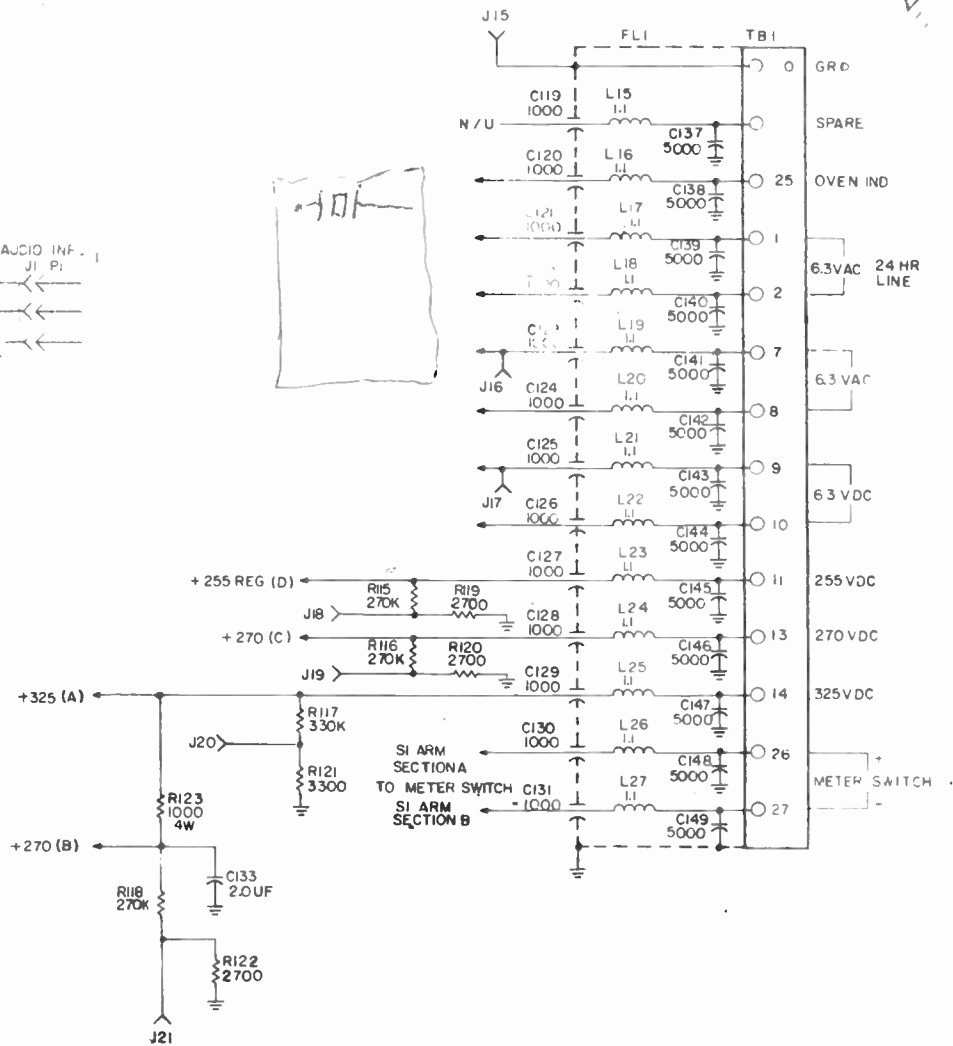
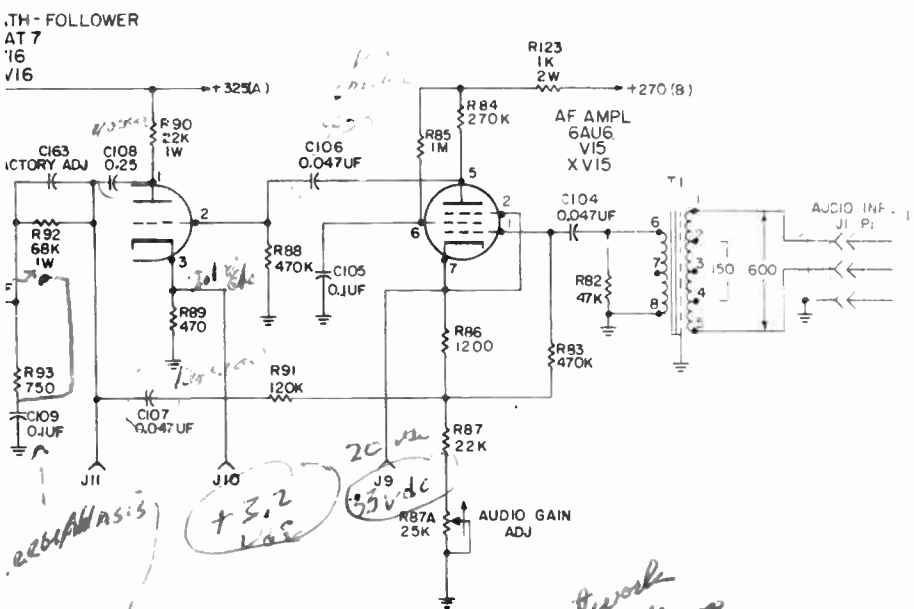
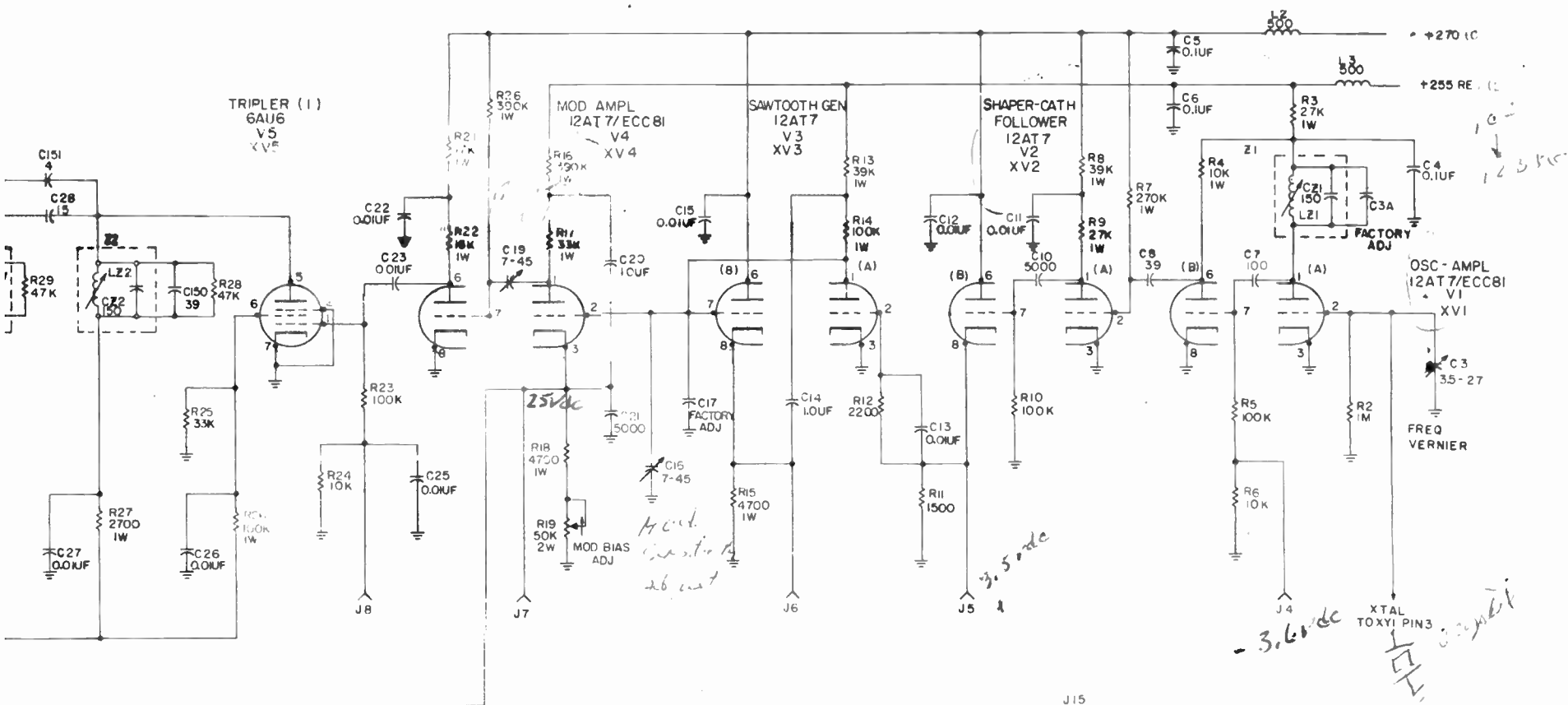

NOTE: when using test meter to test it the meter will load the feedback network & cause 2 cps oscillations at test point #511

NOTES:
1- K=KILO=1,000 MEG=1,000,000 F=PARAD H=HENRY W=WATT
M=MILLI=0.001 S=SECOND U=MICRO=0.000001
2- UNLESS OTHERWISE INDICATED:
A. ALL RESISTANCE VALUES ARE IN OHMS, 1/2 WATT
B. ALL CAPACITANCE VALUES ARE IN UUF
C. ALL INDUCTANCE VALUES ARE IN UH
DIRECTIONAL ARROW AT CONTROLS INDICATES CLOCKWISE ROTATION, VIEWED FROM SHAFT (KNOB) END
OR PARTS LIST SEE P.L. 17-6

Figure 5-5 S-1786 F.M. Modulator Panel (Serrasoid) schematic diagram

L601, L613, L603, L604, L607, L611, L608, L614, L612, L609, L610

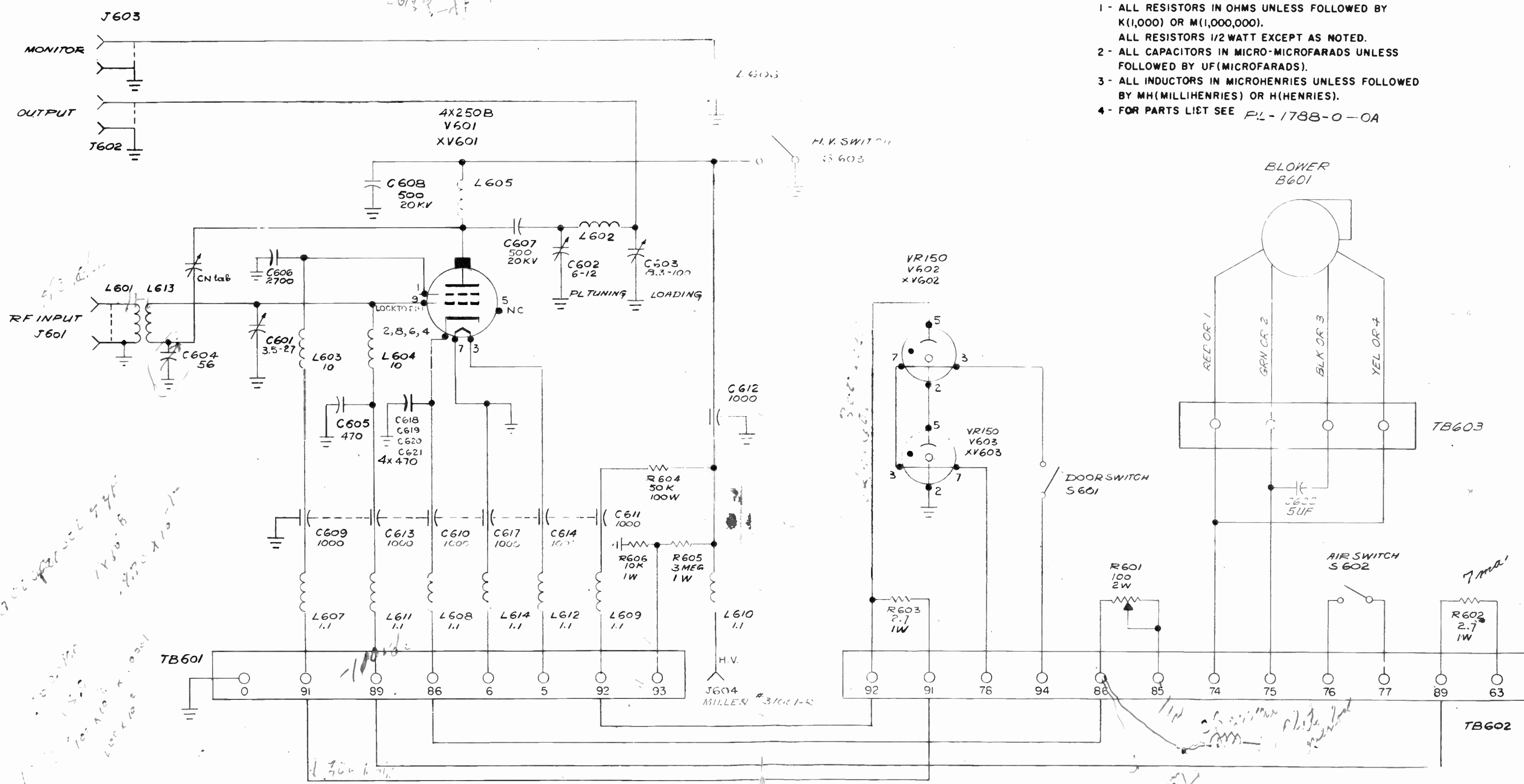

- NOTES**
- 1 - ALL RESISTORS IN OHMS UNLESS FOLLOWED BY K(1,000) OR M(1,000,000). ALL RESISTORS 1/2 WATT EXCEPT AS NOTED.
 - 2 - ALL CAPACITORS IN MICRO-MICROFARADS UNLESS FOLLOWED BY UF(MICROFARADS).
 - 3 - ALL INDUCTORS IN MICROHENRIES UNLESS FOLLOWED BY MH(MILLIHENRIES) OR H(HENRIES).
 - 4 - FOR PARTS LIST SEE PL-1788-0-0A

Figure 5-7 S-1788 250W Power Amplifier, schematic diagram

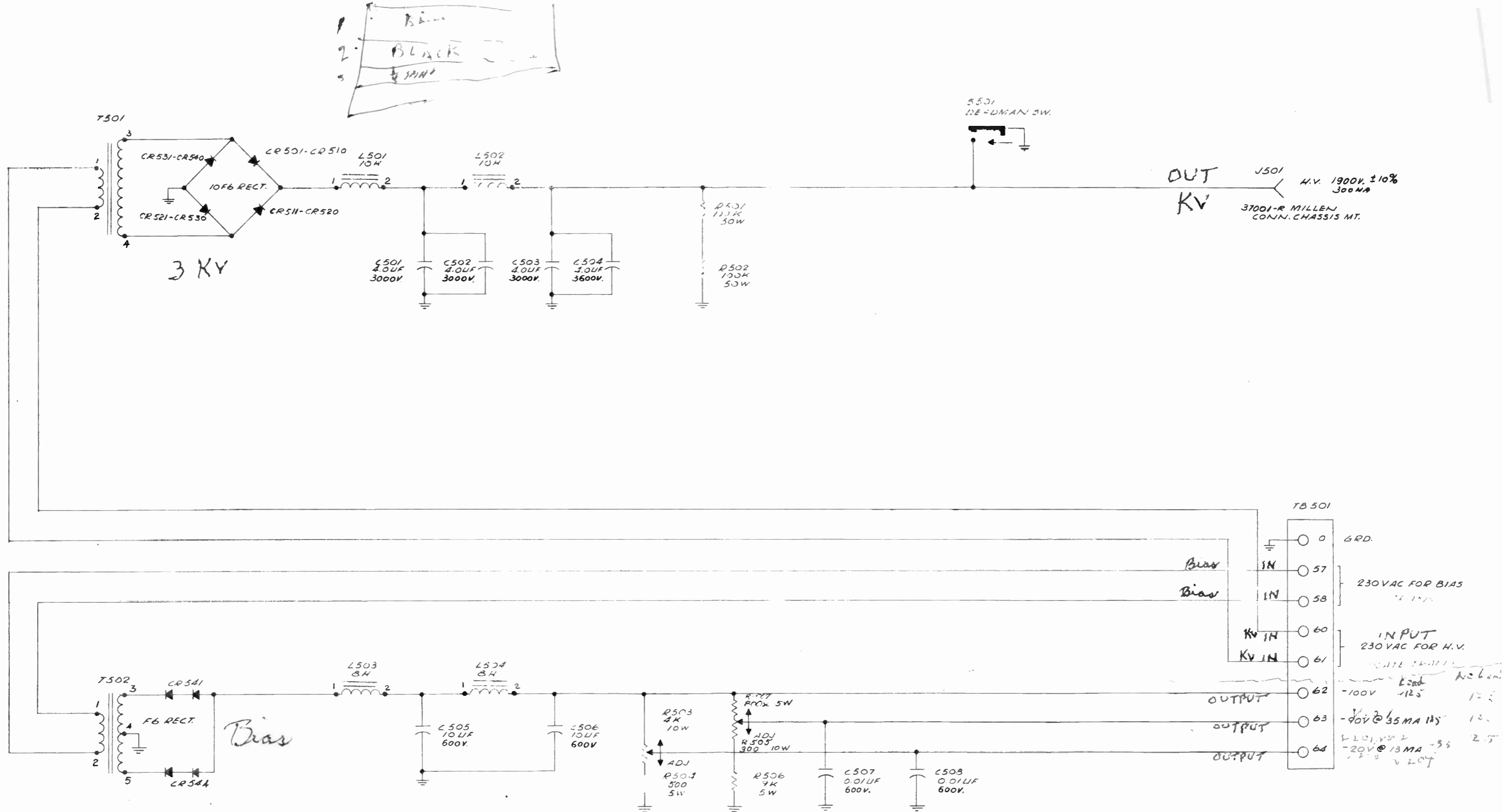

NOTES

- 1 - ALL RESISTORS IN OHMS UNLESS FOLLOWED BY K(1,000) OR M(1,000,000). ALL RESISTORS 1/2 WATT EXCEPT AS NOTED.
- 2 - ALL CAPACITORS IN MICRO-MICROFARADS UNLESS FOLLOWED BY UF(MICROFARADS).
- 3 - ALL INDUCTORS IN MICROHENRIES UNLESS FOLLOWED BY MH(MILLIHENRIES) OR H(HENRIE)
- 4 - FOR PARTS LIST SEE PL-1791-D-DA

Figure 5-9 S-1792 High Voltage Power Supply, schematic diagram

SECTION 6
PARTS LIST

6-1. GENERAL

6-2. The following Part Lists are included in this section.

A. a.	Type S-1789	Cabinet	6-2
B. b.	Type S-1792	H. V. Power Supply	6-4
C. c.	Type S-1791	L. V. Power Supply	6-7
D. d.	Type S-1790	Control Panel	6-10
E. e.	Type S-1786	F. M. Modulator Panel	6-13
F. f.	Type S-1787	Frequency Multiplier	6-30
G. g.	Type S-1788	250W Power Amplifier	6-35
H. h.	Type S-1799	Meter Panel	6-39

A. Type S-1789

CABINET

TYPE S-1789 CABINET

PARTS LIST

<u>Reference Designation</u>	<u>Description</u>	<u>Mfr's Type No.</u>
S901	Switch, sensitive	Micro Switch Div. Minneapolis - Honeywell Regulator Co., Freeport, Ill. Type BZ-2RS
Z901	DC Output directional coupler	M.C. Jones Elect. Co., Inc., Div. of Bendix Aviation Corp., 185 N. Main Street, Bristol, Conn. Model No. 576N6

B. Type S-1792 H.V. POWER SUPPLY

TYPE S-1792 HIGH VOLTAGE

POWER SUPPLY

PARTS LIST

Reference Designation	Description	Mfr's Type No.
C501	Capacitor, Fixed, Paper Dielectric: 4 uf \pm 10%, 3000V dcw, h-s Vect. metal case, two spade - lug intg. brkts.	Cornell-Dubilier TJH-30040
C502	Capacitor, Fixed, Paper Dielectric: 4 uf \pm 10%, 3000V dcw	
C503	Capacitor, Fixed, Paper Dielectric: 4 uf \pm 10%, 3000V dcw	
C504	Capacitor, Fixed, Paper Dielectric: 4 uf \pm 10%, 3000V dcw	
C505	Capacitor, Fixed, Paper Dielectric: 10 uf \pm 10%, 600V dcw; h-s metal case two spade - lug mtg. brkts.	Cornell-Dubilier TJH-6100
C506	Capacitor, Fixed, Paper Dielectric: 10 uf, \pm 10%, 600V dcw	
C507	Capacitor, Fixed, Paper Dielectric: 0.01 uf, \pm 20%, 600V dcw; h-s tubular metal case W/Plastic sleeve	Astron MFFD-6-01
C508	Capacitor, Fixed, Paper Dielectric: 0.01 uf, \pm 20%, 600V dcw	
CR501 CR544	Semiconductor Device, Diode: PIV 600V 420 volts max. rms; 0.8V drop @ 750 ma.F-6 0.275 in. dia., two wire-lead term.	Sarkes-Tareian
J501	Connector, Assembly, Electrical: one male, one female contact, red phenolic body w/mtg. flange, incl. bushing, phg. soldering.	Millen 37001-R
J502	Connector, Receptacle, Electrical: uninsulated banana jack; brass nickel-pltd; w/nut and lug	Gen. Cement 7740
L501	Reactor: 10H	SED Spec. #37322 Dwg. #C-81299
L502	Reactor: 10H	
L503	Reactor: 3H	SED Spec. #37209 Dwg. #C-81097
L504	Reactor: 3H	
P502 P509	Connector, Plug, Electrical: uninsulated banana plug, brass, nickel-pltd., 6-32 tap and cord, w/solder-lug.	Gen. Cement 7737

Reference Designation	Description	Mfr's Type No.
R501=	Resistor, Fixed, Wirewound: ind. wdg; 100,000 ohm \pm 5%, 50W, solder, lug type term. brkt. mtg.	Ward-Leonard 50F-100,000 W/814 mtg. brkts.
R502=	Resistor, Fixed, Wirewound: 100,000 \pm 5%, 50W.	
R503=	Resistor, Adjustable: Wirewound 4,000 ohm \pm 5%, 10W, 3 solder-lug, term. mdg. brkt.	Ward-Leonard 10A-4000 W/829 mtg. brkt.
R504=	Resistor, Fixed, Wirewound: 2500 ohm \pm 5%, 5 watt, ind. wdg.	Ward-Leonard 5F-500c
R505=	Resistor, Adjustable; wirewound, 300 ohm \pm 5%, 10 watt	Ward-Leonard 10A-300 W/829 mtg. brkts.
R506=	Resistor, Fixed, Wirewound: ind. wdg: 9000 ohm \pm 5%, 5 watt, two wire-lead term.	Ward-Leonard 5F-9000
R507=	Resistor, Fixed, Wirewound, 800 ohm \pm 5%, 5 Watt	Ward-Leonard 5F-800
T501=	Transformer, Power Step-Up: Single phase pri; 250V input	SED Spec. #37320 Dwg. #81301
T502=	Transformer, Power, Step-Down: Single Phase pri, 230V Input	SED Spec. #37321 Dwg. #C-81303
TB501=	Terminal Board Black Bakelite; 13 Screw and feed-thru type; 15 amp, 1,200 Vrms; four 0.166 dia mtg. holes	Gen. Prod. 440-Y-13

C. Type S-1791 L. V. Power Supply

TYPE S-1791 LOW VOLTAGE POWER SUPPLY

PARTS LIST

Reference Designation	Description	Mfr's Type No.
C301	Capacitor, Fixed, Paper Dielectric: 10 uf, \pm 10%, 600V; h-s rect. metal case; brkt. mtg.	CP70EIFF 106K W/CPO7SC4 Mtg. Brkt.
C302	Capacitor, Fixed, Paper Dielectric: 10 uf, \pm 10% 600V	
C303	Capacitor, Fixed, Paper Dielectric: 10 uf, \pm 10%, 600 Vdc.	
C305	Capacitor, Fixed, Electrolytic: 500 uf, 25 Vdc, molded plastic case, term. lug; requires item for mtg.	Pyramid Elect. PFM-500-25
C306	Capacitor, Fixed, Paper Dielectric: 0.01 uf, \pm 20%, 600 Vdc, tubular metal case, W/Plastic sleeve	Astron MRFP-6-01
C307	Capacitor, Fixed, Paper Dielectric: 0.01 uf, \pm 20%, 600 Vdc	
CR301	Semiconductor Device, Diode: PIV 600V; 420V max. RMS; term. mtd.	Sarkes-Tareian F-6
CR302	Semiconductor Device, Diode:	
CR303	Semiconductor Device, Diode:	
CR304	Semiconductor Device, Diode:	
CR305	Semiconductor Device, Diode:	
CR306	Semiconductor Device, Diode:	
CR307	Semiconductor Device, Diode: silicon type 1- $\frac{1}{2}$ Ade @ 100 $^{\circ}$ C, 50 PIV, 35 Vrms, max. term. mtd.	Sarkes-Tareian 1N1052 (5P1)
CR308	Semiconductor Device, Diode:	G-V
K301	Relay, Thermal: time delay, SPST, No contacts; rated 230 VAC, 3 Amp 60 sec. time delay	DT-7096
L301	Reactor: 3H	Stand. Elect. #37213
L302	Reactor: 8H	
L303	Reactor: 0.25H @ 1A dc; 1500 Vrms	Stand. Elect. #37319
R301	Resistor, Adjustable: wirewound, ind. wdg; 15,000 ohm, \pm 5%, 25 Watt	Ward-Leonard 25A-15,000 W/826 Brkts.
R302	Resistor, Fixed, Wirewound: ind. wdg., 10,000 ohm, \pm 5%, 5 Watt	Ward-Leonard 5F-10K W/829 Brkts.
R303	Resistor, Fixed, Wirewound: ind. wdg. 4,500 ohm, \pm 5%, 50 watts	Ward-Leonard 10F-4500 W/829 mtg. brkts.

Reference Designation	Description	Mfr's Type No.
R304	Resistor, Adjustable: ind. wdg. Wirewound; 750 ohm \pm 5%, 10W	Ward-Leonard 50A-750 W/814 mtg. brkts.
R305	Resistor, Fixed, Wirewound: ind. wdg., 30,000 ohm, \pm 5%, 10W	Ward-Leonard 10F-30,000 W/829 mtg. brkts.
R306	Resistor, Adjustable, Wirewound: ind. wdg., 3500 ohm, \pm 5%, 10W	Ward-Leonard 10A-3500 W/829 mtg. brkts.
R307	Resistor, Fixed, Wirewound: 30,000 ohm, \pm 5%, 10W	
R308	Resistor, Fixed, Composition: 1 Meg. ohm, \pm 10%, $\frac{1}{2}$ W	Allen-Bradley EB-1051
R309	Resistor, Fixed, Composition: 1 Meg. ohm, \pm 10%, $\frac{1}{2}$ W	
T301	Transformer, Power, Step-Up; 230V pri 1020 Vac. CT @ .254 Amp	Stand. Elect. 37316
T302	Transformer, Power, Step-Down, 230V pri; Secondary 20.6V @ .707A; 6.3V @ 4.5A; 6.3V @ 2A.	Stand. Elect. 37817
T303	Transformer, Power, Step-Down: 230V primary; 6 Vac. @ 2.3-2.9 Amp. Sec.	Stand. Elect. 37318
T304	Transformer, Power, Step-Down: 115V primary, Sec. 6.3 Vac. @ 3A	Stand. Elect. 35988
TB301	Terminal Board: bakelite; 13 screw and feed-thru type; barrier type; 15A, 1200 Vrms.	Gen. Prod. 440-Y-13
TB302	Terminal Board	
V301	Electron Tube: Type OA2	OA2
V302	Electron Tube: Type OB2	OB2
XV301	Socket, Electron Tube: 8 pin. molded body	TS101P01 Jan.-S-28A
XV302	Socket, Electron Tube: 7 pin min; molded body; shock shield base	TS102P01 Jan-S-28A
XV302	Socket, Electron Tube: 7 pin min.	

D. TYPE S-1790 CONTROL PANEL

TYPE S-1790 CONTROL PANEL

PARTS LIST

Reference Designation	Description	Mfr's Type No.
F401	Fuse, Cartridge; ½ amp at 125V; slow blow, ¼ in. dia. by 1¼ in. lg.	Littelfuse 313.500
F402	Fuse, Cartridge; 0.4 amp at 125V slow blow, ¼ in. dia. by 1¼ in. lg.	Littelfuse 313.400
F403	Fuse, Cartridge; ¾ amp at 125V, slow blow, ¼ in. dia. by 1¼ in. lg.	Littelfuse 313.750
F404	Fuse, Cartridge; ¼ amp at 125V slow blow, ¼ in. dia. by 1¼ in. lg.	Littelfuse
I401	Lamp, Glow: Neon, starting voltage about 85 VAC or 120 VDC; T3-¼ clear bulb, min. bayonet base, series resistor required.	GE NE-5TH
I405	Lamp, Incandescent: Rated 6.3V at 250 MA; T3-¼ clear bulb, miniature bayonet base.	GE 44
K401	Relay, Armature: DPST, two normally open contacts, 230V, 50 to 60 cps coil	Struthers-Dunn 215BXX-230 VAC coil with silver cad. oxide con- tacts
K402	Relay, Armature: DPST, two normally open contacts; 115 VDC coil.	Struthers-Dunn 215BXX-115 VDC coil, with silver cad. oxide contacts
M401	Ammeter: 0-100 uamp. movement; 50 scale div. 798 ohms DC resist. approx.	Westinghouse RX33 (1203-650) for 1/8 in. steel panel.
M402	Volt Meter: 0-300 VAC, 25 to 125 cps	Westinghouse RA 33 (1204-030) for 13 ga. steel panel.
R401	Resistor, Variable, Wirewound: 15,000 ohm, \angle 10%, 4W; 3/8-32 mtg. bushing; ¼ in. dia. by 2 in. lg. shaft	Clarostat 10-15K with RS-2 shaft
R402	Resistor, Fixed, Composition: 16 ohms, \angle 5%, ½W	Allen Bradley EB1605

Reference Designation	Description	Mfr's Type No.
R406	Resistor, Fixed, Composition: 82,000 ohm, $\pm 10\%$, $\frac{1}{2}W$	Allen Bradley EB-8231
R410	Resistor, Variable: Wirewound, 10,000 ohms, $\pm 10\%$, 2W, linear taper	Clarostat A43-10K
S401	Circuit Breaker: 2 pole, 8 amp. 230 VAC, 50-60 cps, curve 1 delay	Heinemann 2X0411TS- 8 amp 230V, 50-60-1
S402	Switch, Toggle: DPST - rated 3 amp, 250V, 6 amp at 125 VAC, bat handle; phenolic body; 15/32-32 mtg. bushing	Arrow-Hart and Hegeman 81024-GB
S404	Circuit Breaker	Heinemann X0411TS-3 amp 230V-50to60-3
S405	Switch, Rotary: 2 sections, 1 pole per section, 2 to 11 position with adjustable stop, non-short contacts, 30 deg. index; ceramic sect.	REL C-PP-1130-0A
S406	Switch, Toggle	Arrow-Hart and Hegeman 81021-AF
T401	Transformer, Variable, Power: Primary 187 to 250 volts 50/60 cps. Secondary 230 volts at 7 amps	S.E. Div. - REL Spec. #37323
TB401	Terminal Board: 4 single screw and feed thru type term.	Gen. Prod. 442-Y-4
TB402	Terminal Board: 10 single screw and feed thru type term.	Gen. Prod. 440-Y-10
TB404	Terminal Board: 13 single screw and feed thru type term.	Gen. Prod. 440-Y-13
XFI401	Fuseholder: for $\frac{1}{4}$ in. dia. by $1\frac{1}{4}$ in. lg. Fuse Cartridge; with glow lamp in knob; includes 220,000 ohm resistor, rated 20 amp - 100 to 250V	Bussmann HKL
XI401	Light, Indicator: red multivue cap; for use with NE-51H glow lamp, includes 18,000 ohm resistor.	Dialco 132-408H-991 (red)
XI402	Light, Indicator: Light yellow multivue cap; for use with NE-51H glow lamp; includes 18,000 ohm resistor	Dialco 132-408H-996 (light yellow)
XI403	Light, Indicator: amber multivue cap; for use with NE-51H glow lamp; includes 18,000 ohm resistor.	Dialco 132-408H-993 (Amber)
XI405	Light, Indicator: white translucent color, multivue cap; for incandescent lamp T3- $\frac{1}{4}$ bulb, miniature bayonet base	Dialco 132410-995

E. TYPE S-1786 F. M. MODULATOR PANEL

Reference Designation	Description	Mfr's Type No.
C1	Capacitor, Fixed, Paper Dielectric: 0.1 uf, \pm 20%, 200V	Astron TQF-2-1
C2	Capacitor, Fixed, Ceramic Dielectric: 0.01 uf, \pm 100% & 20%; 500V; disc.	CK63Y1032 MIL-C-11015A
C3	Capacitor, Variable, Air: 3.5-27 uuf, 1500V peak; plate mesh; slotted shaft	E. F. Johnson Type 25L15 Cat. #167-2
C4	Capacitor, Fixed, Paper Dielectric: 0.1 uf, \pm 20%; 400V; screw neck mtg.	CP11A3KE104M MIL-C-25A
C7	Capacitor, Fixed, Ceramic Dielectric: 100 uuf, \pm 10%, 500V; NPO	Centralab TU-3210K00H
C8	Capacitor, Fixed, Ceramic Dielectric: 39 uuf, \pm 10%, 500 dcw; temp. coeff NPO	HI-Q CN27CH390K
C9	Capacitor, Fixed, Ceramic Dielectric: 0.01 uf, \pm 100% -20%; 500V; disc.	
C10	Capacitor, Fixed, Ceramic Dielectric: 5000 uuf, GMV; 1,000 dcw; disc.	Centralab DD-502
C11	Capacitor, Fixed, Ceramic Dielectric: 0.01 uf, \pm 100% -20%; 500V, disc.	
C12	Capacitor, Fixed, Ceramic Dielectric: 0.01 uf, \pm 100% -20%; 500V, disc.	
C13	Capacitor, Fixed, Ceramic Dielectric: 0.01 uf, \pm 100% -20%; 500V, disc.	
C14	Capacitor, Fixed, Paper Dielectric: 1 uf, \pm 20% -10%; 600V dcw; h-s metal case, rectangular.	Aerovox 616MCB-1.0
C14A	Capacitor, Fixed, Ceramic Dielectric: 0.01 uf, \pm 100% -20%; 500V; disc.	
C15	Capacitor, Fixed, Ceramic Dielectric: 0.01 uf, \pm 100% -20%; 500V, disc.	
C16	Capacitor, Variable, Ceramic Dielectric: rotary type: 7 to 45 uuf: 500V dcw: temp. coeff minus 500 ppm/deg C	Erie Resistor TSZA-7-45-500
C17	Factory Adjust	
C18	Capacitor, Fixed, Ceramic Dielectric: 0.01 uf, \pm 100% -20%; 500V, disc.	
C19	Capacitor, Variable, Ceramic Dielectric: rotary type; 7 to 45 uuf; 500V dcw; temp. coeff minus 500 ppm/deg C	
C20	Capacitor, Fixed, Paper Dielectric: 1 uf, \pm 20% -10%; 600V.	
C21	Capacitor, Fixed, Ceramic Dielectric: 5000 uuf GMV; 1000V dcw; disc.	
C22	Capacitor, Fixed, Ceramic Dielectric: 0.01 uf, \pm 100% -20%; 500V; disc.	
C23	Capacitor, Fixed, Ceramic Dielectric: 0.01 uf, \pm 100% -20%; 500V; disc.	
C24	Capacitor, Fixed, Ceramic Dielectric: 5000 uuf GMV; 1000 dcw; disc.	

Reference Designation	Description	Mfr's Type No.
C25	Capacitor, Fixed, Ceramic Dielectric: 0.01 uf, / 100% -20%; 500V, disc.	
C26	Capacitor, Fixed, Ceramic Dielectric: 0.01 uf, / 100% -20%; 500V, disc.	
C27	Capacitor, Fixed, Ceramic Dielectric: 0.01 uf, / 100% -20%; 500V, disc.	
C28	Capacitor, Fixed, Ceramic Dielectric: 15 uuf, / 10%; 500V.	CC20CH150K JAN-C-20A
C29	Capacitor, Fixed, Mica Dielectric: 4700 uuf, / 5%, 500V	CM35C472J MIL-C-5A
C30	Capacitor, Fixed, Ceramic Dielectric: 5000 uuf GMV; 1000V, disc.	
C31	Capacitor, Fixed, Ceramic Dielectric: 0.01 uf, / 100% -20%; 500V, disc.	
C32	Capacitor, Fixed, Ceramic Dielectric: 0.01 uf / 100% -20%; 500V, disc.	
C33	Capacitor, Fixed, Ceramic Dielectric: 0.01 uf, / 100% -20%; 500V disc.	
C34	Capacitor, Fixed, Ceramic Dielectric: 22 uuf, / 5%, 500V	CC20CH220J JAN-C-20A
C35	Capacitor, Fixed, Ceramic Dielectric: 5000 uuf GMV; 1000 dcw; disc.	
C36	Capacitor, Fixed, Ceramic Dielectric: 0.01 uf / 100% -20%; 500V, disc.	
C37	Capacitor, Fixed, Ceramic Dielectric: 0.01 uf / 100% -20%; 500V, disc.	
C38	Capacitor, Fixed, Ceramic Dielectric: 0.01 uf / 100% -20%; 500V, disc.	
C39	Capacitor, Fixed, Ceramic Dielectric: 0.01 uf / 100% -20%; 500V; disc.	
C40	Capacitor, Fixed, Ceramic Dielectric: 0.01 uf / 100% -20%; 500V; disc.	
C41	Capacitor, Fixed, Ceramic Dielectric: 0.01 uf / 100% -20%; 500V; disc.	
C42	Capacitor, Fixed, Ceramic Dielectric: 7 uuf / 0.25 uuf; 500V	CC20CH070C JAN-C-20A
C43	Capacitor, Fixed, Mica Dielectric: 4700 uuf / 5%; 500V	
C44	Capacitor, Fixed, Ceramic Dielectric: 5000 uuf GMV; 1000V, disc.	
C45	Capacitor, Fixed, Ceramic Dielectric: 0.01 uf, / 100% -20%; 500V, disc.	
C46	Capacitor, Fixed, Ceramic Dielectric: 0.01 uf / 100% -20%; 500V; disc.	
C47	Capacitor, Fixed, Ceramic Dielectric: 0.01 uf, / 100% -20%; 500V; disc.	
C48	Capacitor, Fixed, Ceramic Dielectric: 10 uuf, / 0.5 uuf; 500V	CC20CH100D JAN-C-20A
C49	Capacitor, Fixed, Ceramic Dielectric: 0.01 uf, / 100% -20%, 500V; disc.	
C50	Capacitor, Fixed, Ceramic Dielectric: 0.01 uf, / 100% -20%; 500V; disc.	

Reference Designation	Description	Mfr's Type No.
C51	Capacitor, Fixed, Ceramic Dielectric: 5000 uuf GMV; 1000V; disc.	
C52	Capacitor, Fixed, Ceramic Dielectric: 0.01 uf, \neq 100% -20%; 500V; disc.	
C53	Capacitor, Fixed, Ceramic Dielectric: 0.01 uf, \neq 100% -20%; 500V; disc.	
C54	Capacitor, Fixed, Ceramic Dielectric: 3 uuf, \neq 0.1 uuf, 500V	HI-Q C11CJ030 (0.1 uuf)
C63	Capacitor, Fixed, Ceramic Dielectric: 0.01 uf, \neq 100% -20%; 500V, disc.	
C64	Capacitor, Fixed, Ceramic Dielectric: 0.01 uf, \neq 100% - 20%; 500V; disc.	
C65	Capacitor, Fixed, Ceramic Dielectric: 5000 uuf GMV; 1000V; disc.	
C66	Capacitor, Fixed, Ceramic Dielectric: 100 uuf, \neq 10%, 500V	
C67	Capacitor, Fixed, Ceramic Dielectric: 0.01 uf, \neq 100% - 20%; 500V, disc.	
C68	Capacitor, Fixed, Ceramic Dielectric: 47 uuf \neq 5%; 500V	CC30CH470J JAN-C-20A
C69	Capacitor, Fixed, Ceramic Dielectric: 0.01 uf, \neq 100% - 20%; 500V; disc.	
C70	Capacitor, Fixed, Ceramic Dielectric: 5000 uuf GMV; 1000V, disc.	
C71	Capacitor, Fixed, Ceramic Dielectric: 0.01 uf, \neq 100% - 20%; 500V, disc.	
C72	Capacitor, Fixed, Ceramic Dielectrics: 0.01 uf, \neq 100% - 20%; 500V, disc.	
C73	Capacitor, Fixed, Ceramic Dielectric: 6.8 uuf, \neq 0.5 uuf; 600V	Centralab TCZ-6.8
C74	Capacitor, Fixed, Ceramic Dielectric: 5000 uuf GMV; 1000V; disc.	
C75	Capacitor, Fixed, Ceramic Dielectric: 5000 uuf	
C76	Capacitor, Fixed, Ceramic Dielectric: 0.01 uf	
C77	Not Used	
C78	Capacitor, Fixed, Ceramic Dielectric: 0.01 uf, \neq 100% - 20%; 500V, disc.	
C79	Capacitor, Fixed, Ceramic Dielectric: 5000 uuf GMV; 1000V; disc.	
C80	Capacitor, Fixed, Ceramic Dielectric: 5000 uuf; GMV, 1000V, disc.	
C81	Capacitor, Fixed, Ceramic Dielectric: 5000 uuf GMV; 1000V; disc.	
C82	Capacitor, Fixed, Ceramic Dielectric: 5000 uuf GMV; 1000V, disc.	
C83	Capacitor, Fixed, Ceramic Dielectric: 5000 uuf GMV; 1000V, disc.	
C84	Capacitor, Fixed, Ceramic Dielectric: 5000 uuf GMV; 1000V, disc.	
C85	Capacitor, Fixed, Ceramic Dielectric: 5000 uuf GMV; 1000V, disc.	

Reference Designation	Description	Mfr's Type No.
C86	Capacitor, Fixed, Ceramic Dielectric: 5000 uuf GMV; 1000V, disc.	
C87	Capacitor, Fixed, Ceramic Dielectric: 5000 uuf GMV; 1000V, disc.	
C88	Capacitor, Fixed, Ceramic Dielectric: 3 uuf \leq 0.1 uuf; 500V dcw	
C89	Capacitor, Fixed, Ceramic Dielectric: 5000 uuf GMV; 1000V, disc.	
C90	Capacitor, Fixed, Ceramic Dielectric: 5000 uuf GMV; 1000 v disc.	
C91	Capacitor, Fixed, Ceramic Dielectric: 5000 uuf GMV; 100V, disc.	
C92	Capacitor, Fixed, Ceramic Dielectric: 5000 uuf GMV; 1000V, disc.	
C93	Capacitor, Fixed, Ceramic Dielectric: 5000 uuf GMV; 1000V, disc.	
C94	Capacitor, Fixed, Ceramic Dielectric: 5000 uuf GMV; 1000V, disc.	
C95	Capacitor, Fixed, Ceramic Dielectric: 5000 uuf GMV, 1000V, disc.	
C97	Capacitor, Variable, Air Dielectric: 3 uuf-32 uuf; 850V peak, plate meshing type	E. F. Johnson Type 30MB Cat. #160-130
C98	Capacitor, Fixed, Ceramic Dielectric: 5000 uuf GMV; 1000V, disc.	
C99	Capacitor, Fixed, Ceramic Dielectric: 5000 uuf GMV; 1000V, disc.	
C100	Capacitor, Fixed, Ceramic Dielectric: 5000 uuf GMV; 1000V, disc.	
C101	Capacitor, Fixed, Ceramic Dielectric: 5000 uuf GMV; 1000V, disc.	
C102	Capacitor, Fixed, Ceramic Dielectric: 5000 uuf GMV; 1000V, disc.	
C103	Capacitor, Fixed, Mica Dielectric: 220 uuf, \leq 5%; 500V, silver mica.	Elmenco RCM15E221J
C104	Capacitor, Fixed, Paper Dielectric: 0.047 uf, \leq 10%, 400V, term. mtd.	CP05ALEE473K
C105	Capacitor, Fixed, Paper Dielectric: 0.1 uf, \leq 20%, 400V; screw neck mtg.	MIL-C-25A
C106	Capacitor, Fixed, Paper Dielectric: 0.047 uf, \leq 10%; 400V; term. mtd.	
C107	Capacitor, Fixed, Paper Dielectric: 0.047 uf, \leq 10%; 400V, term. mtd.	
C108	Capacitor, Fixed, Paper Dielectric: 0.25 uf, \leq 20% -20%; 400V; term. mtd.	Astron MQCF-4-25
C109	Capacitor, Fixed, Paper Dielectric: 0.1 uf, \leq 20%; 400V, screw neck mtd.	
C110	Capacitor, Fixed, Ceramic Dielectric: 47 uuf, \leq 5%, 500V	

Reference Designation	Description	Mfr's Type No.
C111	Capacitor, Fixed, Paper Dielectric: 0.047 uf, \pm 10%, 400V	
C112	Capacitor, Fixed, Paper Dielectric: 1 uf, \pm 20% -20%, 600V	
C114	Capacitor, Fixed, Mica Dielectric: 470 uuf, \pm 10%, 500V	Elmenco RCM20B471K
C115	Capacitor, Fixed, Mica Dielectric: 220 uuf, \pm 5%, 500V, silver mica	
C116	Capacitor, Fixed, Ceramic Dielectric: 0.01 uf, \pm 100%, - 20%, disc.	
C117	Capacitor, Fixed, Mica Dielectric: 1000 uuf, \pm 5%, 300V	CM20C102J MIL-C-5A
C118	Capacitor, Fixed, Mica Dielectric: 1000 uuf, \pm 5%, 300V	
C119	Capacitor, Fixed, Ceramic Dielectric: 1000 uuf, GMV, 500V dcw; feedthru type; 12-28 thrd. body	Allen Bradley FTB-102W W/nut & Lockwasher
C120	Capacitor, Fixed, Ceramic Dielectric: 1000 uuf, feedthru	
C121	Capacitor, Fixed, Ceramic Dielectric: 1000 uuf, feedthru	
C122	Capacitor, Fixed, Ceramic Dielectric: 1000 uuf, feedthru	
C123	Capacitor, Fixed, Ceramic Dielectric: 1000 uuf, feedthru	
C124	Capacitor, Fixed, Ceramic Dielectric: 1000 uuf, feedthru	
C125	Capacitor, Fixed, Ceramic Dielectric: 1000 uuf, feedthru	
C126	Capacitor, Fixed, Ceramic Dielectric: 1000 uuf, feedthru	
C127	Capacitor, Fixed, Ceramic Dielectric: 1000 uuf, feedthru	
C128	Capacitor, Fixed, Ceramic Dielectric: 1000 uuf, feedthru	
C129	Capacitor, Fixed, Ceramic Dielectric: 1000 uuf, feedthru	
C130	Capacitor, Fixed, Ceramic Dielectric: 1000 uuf, feedthru	
C131	Capacitor, Fixed, Ceramic Dielectric: 1000 uuf, feedthru	
C132	Capacitor, Fixed, Ceramic Dielectric: 5000 uuf GMV, 1000V, disc.	
C133	Capacitor, Fixed, Paper Dielectric: 2 uf, \pm 20%, 400V dcw; screw-neck mtg.	Astron MQCS-4-2M
C137	Capacitor, Fixed, Ceramic Dielectric: 5000 uuf GMV, 1400V, disc.	R.M.C. U-5000
C138	Capacitor, Fixed, Ceramic Dielectric: 5000 uuf GMV, 1400V, disc.	
C139	Capacitor, Fixed, Ceramic Dielectric: 5000 uuf GMV, 1400V, disc.	

Reference Designation	Description	Mfr's Type No.
C140	Capacitor, Fixed, Ceramic Dielectric: 5000 uuf GMV; 1400V, disc.	
C141	Capacitor, Fixed, Ceramic Dielectric: 5000 uuf GMV; 1400V, disc.	
C142	Capacitor, Fixed, Ceramic Dielectric: 5000 uuf GMV; 1400V, disc.	
C143	Capacitor, Fixed, Ceramic Dielectric: 5000 uuf GMV, 1400V, disc.	
C144	Capacitor, Fixed, Ceramic Dielectric: 5000 uuf GMV, 1400V, disc.	
C145	Capacitor, Fixed, Ceramic Dielectric: 5000 uuf GMV; 1400V; disc.	
C146	Capacitor, Fixed, Ceramic Dielectric: 5000 uuf GMV, 1400V, disc.	
C147	Capacitor, Fixed, Ceramic Dielectric: 5000 uuf GMV; 1400V, disc.	
C148	Capacitor, Fixed, Ceramic Dielectric: 5000 uuf GMV; 1400V, disc.	
C149	Capacitor, Fixed, Ceramic Dielectric: 5000 uuf GMV; 1400V, disc.	
C150	Capacitor, Fixed, Mica Dielectric: 39 uuf, \pm 5%, 500V; silver mica	Elmenco RCM15E390J
C151	Capacitor, Fixed, Ceramic Dielectric: 4 uuf, \pm 0.25 uuf; 500V	CC20CH040C JAN-C-20A
C152	Capacitor, Fixed, Ceramic Dielectric: 39 uuf, \pm 10%, 500V	
C153	Capacitor, Fixed, Mica Dielectric: 39 uuf, \pm 5%; 500V, silver mica	
C154	Capacitor, Fixed, Ceramic Dielectric: 5 uuf, \pm 0.25 uuf; 500V	CC20CH050C JAN-C-20A
C155	Capacitor, Fixed, Mica Dielectric: 39 uuf, \pm 5%, 500V; silver mica	
C156	Capacitor, Fixed, Mica Dielectric: 18 uuf, \pm 5%, 500V; silver mica	Elmenco RCM15C180J
C157	Capacitor, Fixed, Ceramic Dielectric: 18 uuf, \pm 5%, 500V	CC20CH180J JAN-C-20A
C158	Capacitor, Fixed, Mica Dielectric: 27 uuf, \pm 5%; 500V, silver mica	
C159	Capacitor, Fixed, Mica Dielectric: 27 uuf, \pm 5%; 500V, silver mica	
C160	Capacitor, Fixed, Mica Dielectric: 2000 uuf, \pm 5%; 500V	CM30C202J MIL-C-5A
C161	Capacitor, Fixed, Mica Dielectric: 1,000 uuf, \pm 10%, 500V	Elmenco RCM19B102K
C162	Capacitor, Fixed, Ceramic Dielectric: 0.01 uf, \pm 100% - 20%; 500V, disc.	
C163	Factory Adjust	
C164	Capacitor, Fixed, Paper Dielectric: 0.1 uf, \pm 20%, 400V	
CZ1	Capacitor, Fixed, Mica Dielectric: 150 uuf, \pm 5%; silver mica	Elmenco RCM15E151J

Reference Designation	Description	Mfr's Type No.
CZ2	Capacitor, Fixed, Mica Dielectric: 150 uuf, \pm 5%, 500V, silver mica	
CZ3	Capacitor, Fixed, Mica Dielectric: 150 uuf, \pm 5%, 500V, silver mica	
CZ4	Capacitor, Fixed, Mica Dielectric: 150 uuf, \pm 5%, 500V, silver mica	
CZ5	Capacitor, Fixed, Mica Dielectric: 150 uuf, \pm 5%, 500V, silver mica	
CZ6	Capacitor, Fixed, Mica Dielectric: 120 uuf, \pm 5%, 500V, silver mica	Elmenco RCM15E121J
CZ7	Capacitor, Fixed, Mica Dielectric: 120 uuf, \pm 5%, 500V, silver mica	
CZ8	Capacitor, Fixed, Mica Dielectric: 120 uuf, \pm 5%, 500V, silver mica	
CZ9	Capacitor, Fixed, Mica Dielectric: 120 uuf, \pm 5%, 500V, silver mica	
CZ10	Capacitor, Fixed, Mica Dielectric: 100 uuf, \pm 5%, 500V, silver mica	Elmenco RCM15E101J
CZ11	Capacitor, Fixed, Mica Dielectric: 100 uuf, \pm 5%, 500V, silver mica	
CZ12	Capacitor, Fixed, Mica Dielectric: 100 uuf, \pm 5%, 500V, silver mica	
CZ13	Capacitor, Fixed, Mica Dielectric: 100 uuf, \pm 5%, 500V, silver mica	
CZ16	Capacitor, Fixed, Mica Dielectric: 100 uuf, \pm 5%, 500V, silver mica	
CZ17	Capacitor, Fixed, Mica Dielectric: 100 uuf, \pm 5%, 500V, silver mica	
CZ18	Capacitor, Fixed, Mica Dielectric: 100 uuf, \pm 5%, 500V, silver mica	
CZ19	Capacitor, Fixed, Mica Dielectric: 100 uuf, \pm 5%, 500V, silver mica	
CZ20	Capacitor, Fixed, Mica Dielectric: 22 uuf, \pm 5%, 500V dcw, silver mica	Elmenco RCM15C220J
CR1	Crystal Unit Rectifying: germanium type; 30 MA max. continuous forward current.	1N198 MIL-E-1C
J1	Connection, Receptacle: straight, two female contacts, microphone connector.	Amphenol 80-PCZF
J2	Connector, Receptacle: straight, two female contacts; microphone connector. Previously desc.	
J4	Jack, Tip: one female contact: black nylon body; $\frac{1}{4}$ -32 threaded metalshell.	I.P.C. 29150-2
J5	Jack, Tip: black nylon body	
J6	Jack, Tip: black nylon body	
J7	Jack, Tip: black nylon body	

Reference Designation	Description	Mfr's Type No.
J8	Jack, Tip: Black nylon body	
J9	Jack, Tip: Black nylon body	
J10	Jack, Tip: Black nylon body	
J11	Jack, Tip: One female contact: orange nylon body; ¼-32 threaded metal shell	I.P.C. 29150-5
J12	Jack, Tip: Black nylon body	
J13	Jack, Tip: Black nylon body	
J14	Jack, Tip: Black nylon body	
J15	Jack, Tip: Black nylon body	
J16	Jack, Tip: Black nylon body	
J17	Jack, Tip: Orange nylon body	
J18	Jack, Tip: Black nylon body	
J19	Jack, Tip: Black nylon body	
J20	Jack, Tip: Orange nylon body	
J21	Jack, Tip: Black nylon body	
J22	Jack, Tip: Orange nylon body	
J24	Connector, Receptacle: RF, BNC type one female contact; straight type.	UG-1094/U MIL-C-3608
L1	Coil, RF: Choke. 1.1 uh, \pm 10% 4.5 amps	C-PP-58-1A
L2	Coil, RF: Choke. 500 uh; 750 MA 7.8 ohm dc resistance	Delevan 5050-32
L3	Coil, RF: Choke, 500 uh; 750 MA	
L4	Coil, RF: Choke, 47 uh, \pm 10%, 100 MA brown color code	C-PP-55-0A
L5	Coil, RF: Choke, 47 uh, \pm 10%, 100 MA	
L6	Coil, RF: Choke, 47 uh, \pm 10%, 100 MA	
L7	Coil, RF: Choke, 47 uh, \pm 10%, 100 MA	
L8	Coil, RF: Choke, 47 uh, \pm 10%, 100 MA	
L10	Coil, RF: Choke, 1.1 uh, \pm 10%, 4.5 amp	
L11	Coil, RF: Choke, 1.1 uh, \pm 10%, 1 amp	C-PP-59-1A
L12	Coil, RF: Choke, 1.1 uh, \pm 10%, 1 amp	
L13	Coil, RF: Choke, 1.1 uh, \pm 10%, 1 amp	
L14	Coil, RF: Choke, 1.1 uh, \pm 10%, 1 amp	
L15	Coil, RF: Choke, 1.1 uh, \pm 10%, 4.5 amp	
L16	Coil, RF: Choke, 1.1 uh, \pm 10%, 4.5 amp	
L17	Coil, RF: Choke, 1.1 uh, \pm 10%, 4.5 amp	
L18	Coil, RF: Choke, 1.1 uh, \pm 10%, 4.5 amp	
L19	Coil, RF: Choke, 1.1 uh, \pm 10%, 4.5 amp	
L20	Coil, RF: Choke, 1.1 uh, \pm 10%, 4.5 amp	
L21	Coil, RF: Choke, 1.1 uh, \pm 10%, 4.5 amp	
L22	Coil, RF: Choke, 1.1 uh, \pm 10%, 4.5 amp	
L23	Coil, RF: Choke, 1.1 uh, \pm 10%, 4.5 amp	
L24	Coil, RF: Choke, 1.1 uh, \pm 10%, 4.5 amp	
L25	Coil, RF: Choke, 1.1 uh, \pm 10%, 4.5 amp	
L26	Coil, RF: Choke, 1.1 uh, \pm 10%, 4.5 amp	
L27	Coil, RF: Choke, 1.1 uh, \pm 10%, 4.5 amp	

Reference Designation	Description	Mfr's Type No.
LZ1	Coil, RF: Oscillator Plate: p/o Z1	C-1786-0-0A Sheet #1
LZ2	Coil, RF: Tripler (1) plate: p/o Z2	C-1786-0-0A Sheet #2
LZ3	Coil, RF: Ampl. (1) Grid: p/o Z3	G-1786-0-0A Sheet #3
LZ4	Coil, RF: Ampl. (1) Plate: p/o Z4: same as LZ2	
LZ5	Coil, RF: Tripler (2) Grid: p/o Z5	C-1786-0-0A Sheet #4
LZ6	Coil, R.F.: Tripler (2) Plate: p/o Z6	C-1786-0-0A Sheet #5
LZ7	Coil, RF: Ampl. (2) Grid. p/o Z7	C-1786-0-0A Sheet #6
LZ8	Coil, RF: Ampl. (2) Plate: p/o Z8; Same as LZ6	
LZ9	Coil, RF: Tripler (3) Grid: p/o Z9	C-1786-0-0A Sheet #7
LZ10	Coil, RF: Tripler (3) Plate: p/o Z10	C-1786-0-0A Sheet #8
LZ11	Coil, RF: Doubler (1) Grid: p/o Z11	C-1786-0-0A Sheet #9
LZ12	Coil, RF: Doubler (1) Plate: p/o Z12	C-1786-0-0A Sheet #10
LZ13	Coil, RF: Ampl. (3) Modulator Grid: p/o Z13	C-1786-0-0A Sheet #11
LZ16	Coil, RF: Ampl. (3) Modulator Plate: p/o Z16. Same as LZ12	
LZ17	Coil, RF: Doubler (2) Grid: p/o Z17	C-1786-0-0A Sheet #12
LZ18	Coil, RF: Doubler (2) Plate: p/o Z18	C-1786-0-0A Sht. #13
LZ19	Coil, RF: Output Ampl. Grid.; p/o Z19	C-1786-0-0A Sheet #14
LZ20	Coil, RF: Output Ampl. Plate: p/o Z20	C-1786-0-0A Sheet #15

Reference Designation	Description	Mfr's Type No.
P1	Connector, Plug: two male contacts microphone type connector	Amphenol 80-mc2m
P2	Connector, Plug: two male contacts microphone type connector	
R1	Resistor, Fixed, Composition; 27 ohms, ∠ 10%; 1W	Allen Bradley GB2701
R2	Resistor, Fixed, Composition; 1 meg ohm, ∠ 10%; 1/2W	A-B EB1051
R3	Resistor, Fixed, Composition; 27,000 ohms, ∠ 10%, 1W	A-B EB2731
R4	Resistor, Fixed, Composition; 10,000 ohms, ∠ 10%, 1W	A-B GB1031
R5	Resistor, Fixed, Composition; 100,000 ohm, ∠ 10%, 1/2W	A-B EB1041
R6	Resistor, Fixed, Composition; 10,000 ohm, ∠ 10%, 1W	A-B EB1031
R7	Resistor, Fixed, Composition; 270,000 ohm, ∠ 10%, 1W	A-B GB2741
R8	Resistor, Fixed, Composition; 39,000 ohm, ∠ 10%, 1W	A-B GB3931
R9	Resistor, Fixed, Composition; 27,000 ohms, ∠ 10%, 1W	A-B GB2731
R10	Resistor, Fixed, Composition; 100,000 ohm, ∠ 10%, 1/2W	A-B EB1041
R11	Resistor, Fixed, Composition; 1,500 ohm, ∠ 10%, 1/2W	A-B EB1521
R12	Resistor, Fixed, Composition; 2,200 ohm, ∠ 10%, 1/2W	A-B EB2221
R13	Resistor, Fixed, Composition; 39,000 ohm, ∠ 10%, 1W	A-B GB3931
R14	Resistor, Fixed, Composition; 100,000 ohm, ∠ 10%, 1W	A-B GB1041
R15	Resistor, Fixed, Composition; 4,700 ohm, ∠ 10%, 1W	A-B GB4721
R16	Resistor, Fixed, Composition; 390,000 ohm, ∠ 10%, 1W	A-B GB3941
R17	Resistor, Fixed, Composition; 33,000 ohm, ∠ 10%, 1W	A-B GB3331
R18	Resistor, Fixed, Composition; 4,700 ohm, ∠ 10%, 1W	
R19	Resistor, Variable: Composition; 50,000 ohms, ∠ 10%; 2W linear taper; 5/8 in. lg. screwdriver slotted shaft. shaft locking type.	A-B JLU-5031 SD4040L
R20	Resistor, Fixed, Composition; 390,000 ohm, ∠ 10%, 1W	
R21	Resistor, Fixed, Composition; 47,000 ohm, ∠ 10%, 1W	A-B GB4731
R22	Resistor, Fixed, Composition; 15,000 ohm, ∠ 10%, 1W	A-B GB1531
R23	Resistor, Fixed, Composition; 100,000 ohm, ∠ 10%, 1/2W	

Reference Designation	Description	Mfr's Type No.
R24	Resistor, Fixed, Composition; 10,000 ohm, \angle 10%, $\frac{1}{2}W$	
R25	Resistor, Fixed, Composition; 33,000 ohm, \angle 10%, $\frac{1}{2}W$	A-B EB3331
R26	Resistor, Fixed, Composition; 100,000 ohm, \angle 10%, 1W	
R27	Resistor, Fixed, Composition; 2,700 ohm, \angle 10%, 1W	A-B GB2721
R28	Resistor, Fixed, Composition; 47,000 ohm, \angle 10%, $\frac{1}{2}W$	A-B EB4731
R29	Resistor, Fixed, Composition; 47,000 ohm, \angle 10%; $\frac{1}{2}W$	
R30	Resistor, Fixed, Composition; 100,000 ohm, \angle 10%, $\frac{1}{2}W$	
R31	Resistor, Fixed, Composition; 390 ohms, \angle 10%, $\frac{1}{2}W$	A-B EB3911
R32	Resistor, Fixed, Composition; 100,000 ohm, \angle 10%, 1W	
R33	Resistor, Fixed, Composition; 2,700 ohm, \angle 10%, 1W	
R34	Resistor, Fixed, Composition; 27,000 ohm, \angle 10%, $\frac{1}{2}W$	A-B EB2731
R35	Resistor, Fixed, Composition; 82,000 ohm, \angle 10%, $\frac{1}{2}W$	A-B EB8231
R36	Resistor, Fixed, Composition; 100,000 ohm, \angle 10%, $\frac{1}{2}W$	
R37	Resistor, Fixed, Composition; 820 ohms, \angle 10%, $\frac{1}{2}W$	A-B EB8211
R38	Resistor, Fixed, Composition; 100,000 ohm, \angle 10%, 1W	
R39	Resistor, Fixed, Composition; 2,700 ohm, \angle 10%, 1W	
R40	Resistor, Fixed, Composition; 47,000 ohm, \angle 10%, $\frac{1}{2}W$	
R41	Resistor, Fixed, Composition; 47,000 ohm, \angle 10%, $\frac{1}{2}W$	
R42	Resistor, Fixed, Composition; 100,000 ohm, \angle 10%, $\frac{1}{2}W$	
R43	Resistor, Fixed, Composition; 390 ohms, \angle 10%, $\frac{1}{2}W$	
R44	Resistor, Fixed, Composition; 100,000 ohm, \angle 10%, 1W	
R45	Resistor, Fixed, Composition; 2,700 ohm, \angle 10%, 1W	
R46	Resistor, Fixed, Composition; 27,000 ohm, \angle 10%, $\frac{1}{2}W$	
R47	Resistor, Fixed, Composition; 47,000 ohm, \angle 10%, $\frac{1}{2}W$	
R48	Resistor, Fixed, Composition; 100,000 ohm, \angle 10%, $\frac{1}{2}W$	
R49	Resistor, Fixed, Composition; 1,500 ohm, \angle 10%, $\frac{1}{2}W$	

Reference Designation	Description	Mfr's Type No.
R50	Resistor, Fixed, Composition; 100,000 ohm, \angle 10%, 1W	
R51	Resistor, Fixed, Composition; 2,700 ohm \angle 10%, 1W	
R52	Resistor, Fixed, Composition; 68,000 ohm, \angle 10%, $\frac{1}{2}$ W	A-B EB6831
R53	Resistor, Fixed, Composition; 33 ohm \angle 10%, $\frac{1}{2}$ W	A-B EB3301
R54	Resistor, Fixed, Composition; 150,000 ohms, \angle 10%, $\frac{1}{2}$ W	A-B EB1541
R55	Resistor, Fixed, Composition; 1,200 ohm, \angle 10%, $\frac{1}{2}$ W	A-B EB1221
R56	Resistor, Fixed, Composition; 22,000 ohm, \angle 10%, $\frac{1}{2}$ W	A-B EB2231
R57	Resistor, Fixed, Composition; 2,700 ohm, \angle 10%, 1W	
R58	Resistor, Fixed, Composition; 100,000 ohm, \angle 10%, $\frac{1}{2}$ W	
R59	Resistor, Fixed, Composition; 100,000 ohm, \angle 10%, $\frac{1}{2}$ W	
R60	Resistor, Fixed, Composition; 10,000 ohm, \angle 10%, $\frac{1}{2}$ W	
R61	Resistor, Fixed, Composition; 100,000 ohm, \angle 10%, $\frac{1}{2}$ W	A-B EB1045
R62	Resistor, Fixed, Composition; 100,000 ohms, \angle 10%, $\frac{1}{2}$ W	
R63	Resistor, Fixed, Composition; 10,000 ohms, \angle 10%, 2W	A-B HB1031
R64	Resistor, Fixed, Composition; 20,000 ohms, \angle 5%, 2W	A-B HB2035
R65	Resistor, Fixed, Composition; 10,000 ohms, \angle 10%, $\frac{1}{2}$ W	
R66	Resistor, Fixed, Composition; 12,000 ohm, \angle 10%, $\frac{1}{2}$ W	A-B EB1231
R67	Resistor, Fixed, Composition; 75,000 ohm, \angle 5%, $\frac{1}{2}$ W	A-B EB7535
R68	Resistor, Fixed, Composition; 1,200 ohm, \angle 10%, $\frac{1}{2}$ W	
R69	Resistor, Fixed, Composition; 100 ohm \angle 10%, $\frac{1}{2}$ W	A-B EB1011
R70	Resistor, Fixed, Composition; 10 ohm \angle 10%, $\frac{1}{2}$ W	A-B EB1001
R71	Resistor, Fixed, Composition; 68,000 ohm, \angle 10%, 1W	A-B GB6831
R72	Resistor, Fixed, Composition; 1,000 ohm, \angle 10%, $\frac{1}{2}$ W	A-B EB1021
R73	Resistor, Fixed, Composition; 6,800 ohm, \angle 10%, $\frac{1}{2}$ W	
R74	Resistor, Fixed, Composition; 10,000 ohm, \angle 10%, $\frac{1}{2}$ W	
R75	Resistor, Fixed, Composition; 10,000 ohm, \angle 10%, $\frac{1}{2}$ W. Previously disc.	
R76	Resistor, Fixed, Composition; 1,000 ohm, \angle 10%, $\frac{1}{2}$ W	

Reference Designation	Description	Mfr's Type No.
R77	Resistor, Fixed, Composition; 100 ohm ± 10%, 1/2W	
R78	Resistor, Fixed, Composition; 4.7 ohm ± 10%, 1W	
R79	Resistor, Fixed, Composition; 68,000 ohm, ± 10%, 1W	
R80	Resistor, Fixed, Composition; 100,000 ohm, ± 10%, 1/2W	
R81	Resistor, Fixed, Composition; 1,800 ohm, ± 10%, 1/2W	A-B EB1821
R82	Resistor, Fixed, Composition; 47,000 ohm, ± 10%, 1/2W	
R83	Resistor, Fixed, Composition; 470,000 ohm, ± 10%, 1/2W	A-B EB4741
R84	Resistor, Fixed, Composition; 270,000 ohm, ± 10%, 1/2W	A-B EB2741
R85	Resistor, Fixed, Composition; 1 MEG ohm, ± 10%, 1/2W	
R86	Resistor, Fixed, Composition; 1,200 ohm, ± 10%, 1/2W	
R87	Resistor, Fixed, Composition; 22,000 ohm, ± 10%, 1/2W	
R88	Resistor, Variable, Composition; 25,000 ohm, ± 10%, 2W; linear taper 5/8 in. long screwdriver slotted shaft, shaft locking type.	A-B JLU-2531 SD40-40L
R89	Resistor, Fixed, Composition; 470,000 ohm, ± 10%, 1/2W	
R90	Resistor, Fixed, Composition; 470 ohm, ± 10%, 1/2W	A-B EB4711
R91	Resistor, Fixed, Composition; 22,000 ohm, ± 10%, 1W	A-B GB2231
R92	Resistor, Fixed, Composition; 120,000 ohm, ± 10%, 1/2W	A-B EB1241
R93	Resistor, Fixed, Composition; 68,000 ohm, ± 10%, 1W	
R94	Resistor, Fixed, Composition; 750 ohm ± 5%, 1/2W	A-B EB756
R95	Resistor, Fixed, Composition; 470,000 ohm, ± 10%, 1/2W	
R96	Resistor, Fixed, Composition; 100 ohm ± 10%, 1/2W	
R97	Resistor, Fixed, Composition; 470 ohm ± 10%, 1/2W	
R98	Resistor, Fixed, Composition; 10,000 ohm, ± 10%, 1W	
R99	Resistor, Fixed, Composition; 620 ohm ± 10%, 1/2W	A-B EB6215
R100	Resistor, Variable, Composition; 25,000 ohm, ± 10%, 2W; linear taper; 5/8 in. lg. screwdriver slotted shaft; shaft locking type.	A-B JLU-2541 SD4040L

Reference Designation	Description	Mfr's Type No.
R101	Resistor, Fixed, Composition: 82,000 ohm, $\pm 10\%$, $\frac{1}{2}W$	
R102	Resistor, Fixed, Composition: 120,000 ohm, $\pm 10\%$, $\frac{1}{2}W$	
R103	Resistor, Fixed, Composition: 1,000 ohm, $\pm 10\%$, $\frac{1}{2}W$	
R104	Resistor, Fixed, Composition: 10,000 ohm, $\pm 10\%$, $\frac{1}{2}W$	
R105	Resistor, Fixed, Composition: 100,000 ohm, $\pm 10\%$, $\frac{1}{2}W$	
R106	Resistor, Fixed, Composition: 51,000 ohm, $\pm 5\%$, 1W	A-B GB5135
R107	Resistor, Fixed, Composition: 1,200 ohm, $\pm 10\%$, $\frac{1}{2}W$	
R108	Resistor, Fixed, Composition: 150,000 ohm, $\pm 10\%$, $\frac{1}{2}W$	
R109	Resistor, Fixed, Composition: 33,000 ohm, $\pm 10\%$, $\frac{1}{2}W$	
R110	Resistor, Fixed, Composition: 150 ohm $\pm 10\%$, $\frac{1}{2}W$	A-B EB1511
R111	Resistor, Fixed, Composition: 10,000 ohm, $\pm 10\%$, $\frac{1}{2}W$	
R112	Resistor, Fixed, Composition: 4,700 ohm, $\pm 10\%$, $\frac{1}{2}W$	A-B EB4721
R113	Resistor, Fixed, Composition: 560 ohm $\pm 10\%$, $\frac{1}{2}W$	A-B EB5611
R114	Resistor, Fixed, Composition: 3,900 ohm, $\pm 10\%$, $\frac{1}{2}W$	A-B EB3921
R115	Resistor, Fixed, Composition: 27,000 ohm, $\pm 10\%$, $\frac{1}{2}W$	
R116	Resistor, Fixed, Composition: 270,000 ohm, $\pm 10\%$, $\frac{1}{2}W$	A-B EB2745
R117	Resistor, Fixed, Composition: 270,000 ohm, $\pm 5\%$, $\frac{1}{2}W$	
R118	Resistor, Fixed, Composition: 330,000 ohm, $\pm 5\%$, $\frac{1}{2}W$	A-B EB3345
R119	Resistor, Fixed, Composition: 270,000 ohm, $\pm 5\%$, $\frac{1}{2}W$	
R120	Resistor, Fixed, Composition: 2,700 ohm, $\pm 5\%$, $\frac{1}{2}W$	A-B EB2725
R121	Resistor, Fixed, Composition: 2,700 ohm, $\pm 5\%$, $\frac{1}{2}W$	
R122	Resistor, Fixed, Composition: 3,300 ohm, $\pm 5\%$, $\frac{1}{2}W$	A-B EB3325
R123	Resistor, Fixed, Composition: 2,700 ohm, $\pm 5\%$, $\frac{1}{2}W$	
R124	Resistor, Fixed, Composition: 1,000 ohm, $\pm 10\%$, 4W at 70° C max. amb.	A-B HM1021
R125	Resistor, Fixed, Composition: 1,000 ohm, $\pm 10\%$, 1W	A-B GB1021
R126	Resistor, Fixed, Composition: 270 ohm $\pm 10\%$, 1W	A-B GB2711
S1	Switch, Rotary: altered by REL	REL C-PA-1480-0A

Reference Designation	Description	Mfr's Type No.
T1	Transformer: AF	S.E. Div -
T2	Transformer: AF	Spec. #37303 S.E. Div - S-37281
TB1	Terminal Board: 14 screw and feed thru type terminals; barrier type	General Prod. 464-Y-14
V1	Electron Tube: 12AT7/ECC81	Amperex
V2	Electron Tube: 12AT7	
V3	Electron Tube: 12AT7	
V4	Electron Tube: 12AT7/ECC81	
V5	Electron Tube: 6AU6	
V6	Electron Tube: 6AU6	
V7	Electron Tube: 6AU6	
V8	Electron Tube: 6AU6	
V9	Electron Tube: 6AU6	
V10	Electron Tube: 6AU6	
V11	Electron Tube: 6AH6	
V12	Electron Tube: 6AS6	
V13	Electron Tube: 6AH6	
V14	Electron Tube: 5636	
V15	Electron Tube: 6AU6	
V16	Electron Tube: 12AT7	
V17	Electron Tube: 12AT7	
XV1	Socket, Electron Tube: 9 contacts noval; with shock shield	TS103P01 w/beryllium-copper contacts JAN-S-28A
XV2	Socket, Electron Tube: 9 contacts	
XV3	Socket, Electron Tube: 9 contacts	
XV4	Socket, Electron Tube: 9 contacts	
XV5	Socket, Electron Tube: 7 contacts miniature size; with shock shield	TS102P01 w/beryllium-copper contacts JAN-S-28A
XV6	Socket, Electron Tube: 7 contacts	
XV7	Socket, Electron Tube: 7 contacts	
XV8	Socket, Electron Tube: 7 contacts	
XV9	Socket, Electron Tube: 7 contacts	
XV10	Socket, Electron Tube: 7 contacts	
XV11	Socket, Electron Tube: 7 contacts	
XV12	Socket, Electron Tube: 7 contacts	
XV13	Socket, Electron Tube: 7 contacts	
XV14	Socket, Electron Tube: 9 contacts	
XV15	Socket, Electron Tube: 7 contacts	
XV16	Socket, Electron Tube: 9 contacts	
XV17	Socket, Electron Tube: 9 contacts	

Reference Designation	Description	Mfr's Type No.
XY1	Socket, Electron Tube: giant 7 pin, ceramic base (REL # X-5119)	E. F. Johnson 122-237-1
Y1	Consists of:- Oven Crystal: Crystal Unit: Quartz, Frequency to to specified, parallel resonant mode: to be calibrated in circuit similar to STANDARD ELECTRONICS DIVISION, type #6013A FM Exciter drawing number - D-100,073, except for frequency range.	C-PP-928-0A
Z1	Tuned Circuit: c/o CZ1, LZ1	
Z2	Tuned Circuit: c/o CZ2, LZ2	
Z3	Tuned Circuit: c/o CZ3, LZ3	
Z4	Tuned Circuit: c/o CZ4, LZ4	
Z5	Tuned Circuit: c/o CZ5, LZ5	
Z6	Tuned Circuit: c/o CZ6, LZ6	
Z7	Tuned Circuit: c/o CZ7, LZ7	
Z8	Tuned Circuit: c/o CZ8, LZ8	
Z9	Tuned Circuit: c/o CZ9, LZ9	
Z10	Tuned Circuit: c/o CZ10, LZ10	
Z11	Tuned Circuit: c/o CZ11, LZ11	
Z12	Tuned Circuit: c/o CZ12, LZ12	
Z13	Tuned Circuit: c/o CZ13, LZ13	
Z16	Tuned Circuit: c/o CZ14, LZ14	
Z17	Tuned Circuit: c/o CZ15, LZ15	
Z18	Tuned Circuit: c/o CZ16, LZ16	
Z19	Tuned Circuit: c/o CZ17, LZ17	
Z20	Tuned Circuit: c/o LZ20	

F. Type S-1787 FREQUENCY MULTIPLIER

Reference Designation	Description	Mfr's Type No.
C201	Capacitor, Fixed, Mica Dielectric: Silver, 5%, 500V	Elmenco RCM15E101J
C202	Capacitor, Fixed, Mica Dielectric: Silver, 56 uuf, 5%, 500V	Elmenco RCM15E560J
C203	Capacitor, Fixed, Mica Dielectric: Silver, 12 uuf, 5%, 500V	Elmenco RCM15C120J
C204	Capacitor, Fixed, Mica Dielectric: Silver, 100 uuf, 5%, 500V	
C205	Capacitor, Fixed, Ceramic Dielectric: 1000 uuf, 1500V	Centralab DD-102
C206	Capacitor, Fixed, Ceramic Dielectric: 1000 uuf, GMV, 1000V	
C207	Capacitor, Fixed, Ceramic Dielectric: 470 uuf, 600V	Erie ED-.00047
C208	Capacitor, Fixed, Ceramic Dielectric: 470 uuf, 500V	
C209	Capacitor, Fixed, Ceramic Dielectric: 470 uuf, 500V	
C210	Capacitor, Variable, Ceramic Dielectric: 1.5 - 7.0 uuf, NPO, 500V	Erie TS2A-1.5-7-NPO
C211	Capacitor, Fixed, Dielectric: Mica: Silver, 560 uuf, 5%, 500V	Elmenco RCM20D561J
C212	Capacitor, Fixed, Ceramic Dielectric: 1 uuf, \leq .25 uuf, 500V	CC21CK010C JAN-C-20A
C213	Capacitor, Variable Air Dielectric: 2.9-19.6 uuf	E. F. Johnson 20 MH
C214	Capacitor, Fixed, Ceramic Dielectric: disc. 470 uuf; GMV, 500V	
C215	Capacitor, Fixed, Ceramic Dielectric: 47 uuf, GMV, 500V	CC30CH470J JAN-C-20A
C216	Capacitor, Fixed, Ceramic Dielectric: disc. 470 uuf, GMV, 500V	
C217	Capacitor, Fixed, Ceramic Dielectric: 470 uuf, GMV, 500V	
C218	Capacitor, Fixed, Ceramic Dielectric: 470 uuf, GMV, 500V	
C219	Capacitor, Variable Air Dielectric: 3.52 uuf, without chassis mounting brkt.	E. F. Johnson 167-2 (25L15)
C220	Capacitor, Variable, Air Dielectric: 2.3-14.2 uuf, shaft mounted; 1250	E. F. Johnson 160-107 (15M11)
C221	Capacitor, Fixed, Ceramic Dielectric: 470 uuf, GMV, 500V	
C222	Capacitor, Variable, Air Dielectric: 2.7-19.6 uuf	E. F. Johnson 20M11
C223	Capacitor, Fixed, Ceramic Dielectric: Feedthru 1000 uuf, 500V	Allen Bradley FTB-102W with nut and lockwasher
C224	Capacitor, Fixed, Ceramic Dielectric: Feedthru, 1000 uuf, GMV, 500V	
C225	Capacitor, Fixed, Ceramic Dielectric: Feedthru, 1000 uuf, GMV, 500V	

Reference Designation	Description	Mfr's Type No.
C226	Capacitor, Fixed, Ceramic Dielectric: Feedthru, 1000 uuf, GMV, 500V	
C227	Capacitor, Fixed, Ceramic Dielectric: Feedthru, 1000 uuf, GMV, 500V	
C228	Capacitor, Fixed, Ceramic Dielectric: Feedthru, 1000 uuf, GMV, 500V	
C229	Capacitor, Fixed, Ceramic Dielectric: Feedthru, 1000 uuf, GMV, 500V	
C230	Capacitor, Fixed, Ceramic Dielectric: Feedthru, 1000 uuf, GMV, 500V	
C231	Capacitor, Fixed, Ceramic Dielectric: disc. 1000 uuf, GMV, 1000V	
C232	Capacitor, Fixed, Ceramic Dielectric: 470 uuf, GMV, 1500V	
C233	Capacitor, Fixed, Ceramic Dielectric: 470 uuf, GMV, 500V	
C234	Capacitor, Fixed, Ceramic Dielectric: 470 uuf, GMV, 500V	
C235	Capacitor, Fixed, Ceramic Dielectric: 1000 uuf, Feedthru, GMV, 500V	
J201	Connector, Receptacle: BNC	UG-625 A/U-MIL-C-360
J202	Jack, Tip: Black nylon	E. F. Johnson 105-603-1
J203	Jack, Tip: Black nylon	
J204	RF Connector Receptacle: BNC	
J208	Jack, Tip: Yellow	E. F. Johnson 105-607-1
L201	Doubler Grid Coil	C-1787-0-0A Sheet #1
L202	Doubler (1) Plate Coil	C-1787-0-0A Sheet #2
L203	Doubler (1) Plate Coil	C-1787- Sheet #3
L204	Coil, RE: 7.0 uh	Ohmite Z50
L205	Doubler (2) Grid Coil	C-1787 Sheet #4
L206	Coil, RE: color coded green; 1.8 uh, one amp	Ohmite Z144
L207	Coil, RF: 1.8 uh	
L208	Doubler (3) Plate Coil	C-1787- Sheet #5
L209	Ampl. (1) Plate Coil	C-1787- Sheet #6
L210	Output Coil	C-1787- Sheet #7
L211	Coil, RE: 1.8 uh	
L212	Coil, RF: 1.1 uh, 4.5 amp	
		C-PP-58-1A

Reference Designation	Description	Mfr's Type No.
L213	Coil, RF: 1.1 uh, 4.5 amp	
L214	Coil, RF: 7.0 uh	
L215	Coil, RF: 1.8 uh	
L216	Coil, RF: 1.8 uh	
L217	Coil, RF: 4.7 uh, 100 MA	REL C-PP-55-0A
L218	Coil, 4.7 uh: 100 MA RF	
L219	Coil, RF: 7.0 uh	
L220	Coil, RF: 1.8 uh	
L221	Coil, RF: 7.0 uh	
P201	Connector Plug RF: Type BNC	UG-88C/V
P204	Connector Plug RF: Type BNC	
R201	Resistor, Fixed, Composition: 10%, 1/2W, 27K	Ailen Bradley EB2731
R202	Resistor, Fixed, Composition: 10%, 2W, 2.2K	A-B
R203	Resistor, Fixed, Composition: 10%, 1/2W, 27K	
R204	Resistor, Fixed, Composition: 10%, 2W, 212K	
R205	Resistor, Fixed, Composition: 10%, 1/2W, 22K	A-B EB2231
R206	Resistor, Fixed, Composition: 5%, 1/2W, 1.5 Meg.	A-B EB1555
R207	Resistor, Fixed, Composition: 5%, 1/2W, 12K	A-B EB1235
R208	Resistor, Fixed, Composition: 5%, 1/2W, 12K	
R209	Resistor, Fixed, Composition: 5%, 1/2W, 1.5 Meg.	
R210	Resistor, Fixed, Composition: 10%, 1/2W, 68K	A-B EB6831
R211	Resistor, Fixed, Composition: 10%, 1/2W, 22K	A-B GB2231
R212	Resistor, Fixed, Composition: 10%, 2W, 4.7K	A-B HB4721
R213	Resistor, Fixed, Composition: 5%, 1/2W, 270K	A-B EB2745
R214	Resistor, Fixed, Composition: 5%, 1/2W, 1.5K	A-B EB1525
R215	Resistor, Fixed, Composition: 5%, 1/2W, 220K	A-B EB2245
R216	Resistor, Fixed, Composition: 5%, 1/2W, 2.2K	A-B EB2225
R217	Resistor, Fixed, Composition: 5%, 1/2W, 390K	A-B EB3945
R218	Resistor, Fixed, Composition: 5%, 1/2W, 2.0K	A-B EB2025

Reference Designation	Description	Mfr's Type No.
TB201	Terminal Board: 11 term.	Gen. Prod. 464-Y-11
V201	Electron Tube: 6C4	
V202	Electron Tube: 6C4	
V203	Electron Tube: 6360	
V204	Electron Tube: 2E26	
XV201	Socket Electron Tube: 7 contacts	TS102P01 JAN-S-28A
XV202	Socket Electron Tube:	
XV203	Socket Electron Tube: 9 contacts	Cinch Mfg. 12884
XV204	Socket Electron Tube: 8 contacts	TS101P01 JAN-S-28A
E5021	Shield Electron Tube:	TS102U01 JAN-S-28A
E5578	Heat Shield Electron Tube:	IERC T6-1001-B
E5635	Heat Shield Electron Tube:	IERC NWG-6530

G. Type S-1788 250W POWER AMPLIFIER

Reference Designation	Description	Mfr's Type No.
B601	Blower: 230V, 50 to 60 cps, 3350 RPM free air delivery 64 CFM max.	Rotron Model #DCPR Re-order #A0-20912
C601	Capacitor, Variable, Air Dielectric: Plate meshing type, 3.5 to 27 uuf, 3000 volts peak breakdown	E. F. Johnson 25L30 with 0.060 in. plate spacing
C602	Capacitor, Variable, Air Dielectric: Plate meshing type; 6 to 12 uuf, slotted shaft	Cardwell PL-7113 Type NA-10-NS
C603	Capacitor, Variable, Air Dielectric: Plate meshing type; 8.3 to 100 uuf, 1000 Vrms test.	Hammerland MC-100-S
C604	Capacitor, Fixed, Ceramic Dielectric: 56 uuf, \pm 10%, 500V, NPO, uninsulated tubular	H1-Q CN2-56 uuf \pm 10% NPO
C605	Capacitor, Fixed, Ceramic Dielectric: 470 uuf, GMV, 600V, disc.	Erie ED-.00047
C606	Capacitor, Fixed: 2700 uuf, 400V part of XY601	
C607	Capacitor, Fixed, Ceramic Dielectric: 500 uuf, \pm 50% -20%, 20,000V, round molded case	
C608	Same as C607	
C609	Capacitor, Fixed, Ceramic Dielectric: 1,000 uuf, GMV, 500V, Feedthru; 12-28 by 5/16 in. lg. body mounted.	Allen Bradley FTB-102W with nut and lockwasher
C610	Same as C609	
C611	Same as C609	
C612	Capacitor, Fixed, Ceramic Dielectric: Feedthru, 1500 uuf, 2000V dcw, 3/8-32 threaded body	C-PP-1232-0A
C613	Same as C609	
C614	Same as C609	
C615	Same as C609	
C616	Same as C605	
C617	Same as C609	
C618	Same as C605	
C619	Same as C605	
C620	Same as C605	
C621	Same as C605	
C622	Capacitor, Fixed, Paper Dielectric: 0.5 uf, \pm 10%, 330 VAC	Cornell Dubilier KGN3005
J601	Connector Receptacle: RF, BNC, one one round female contact; straight type	UG-1094/U MIL-C-3608
J602	Connector, Receptacle: RF, Type N, one round female contact; straight type, square mounting flange.	UG-58A/U MIL-C-71A

Reference Designation	Description	Mfr's Type No. or REL Dwg. No.
J603	Connector, Receptacle: RF, UHF, one round female contact, straight type	Amphenol 83-1R
J604	Connector, Assembly, Electrical: one male and one female contact red phenolic body w/mtg flange, includes bushing, plug, lug	Millen 37001-R
L601	Coil, Radio Frequency: half turn loop #12 bus wire	
L602	Coil, Radio Frequency: ¼ in. copper tube "U" bend 2½ in. dia.	
L603	Coil, RF: Choke. 10 uh, \pm 10%, 100 MA Orange color code	C-PP-57-0A
L604	Same as L603	
L605	Coil, Radio Frequency: Miniductor: 16 turns per inch, 5/8 in. dia. by 2 in. lg.	Barker and Williamson #3007
L606	Coil, Radio Frequency: single turn loop ½ in. dia.	
L607	Coil, RF: Choke. 1.1 uh, \pm 10%, one amp	C-PP-59-1A
L608	Same as L607	
L609	Same as L607	
L610	Same as L607	
L611	Same as L607	
L612	Coil, RF: Choke. 1.1 uh, \pm 10%, 4.5 amp	C-PP-58-1A
L613	Coil, Radio Frequency: half turn loop #12 bus	
P601	Connector Plug: RF, BNC, one round male contact, straight type	UG-21 D/U
P602	Connector Plug: RF, Type N, one round male contact, straight type	UG-21 D/U MIL-C-71A
P603	Connector Plug: RF, UHF, one round male contact	Amphenol 83-LSP
R601	Resistor, Variable: Composition: 100 ohm, \pm 10%, 2W, linear taper, slotted shaft 5/8 in. lg. from mtg. surface; shaft locking type	Allen Bradley JLU-1011 SD4040L
R602	Resistor, Fixed, Composition: 2.7 ohm \pm 10%, 1W	Allen Bradley GB27G1
R604	Resistor, Adjustable Wirewound: 50,000 ohm, \pm 5%, 100W	Ward Leonard 100A50,000 W/815 brkt.
R605	Resistor, Fixed, Film: 3 MEG ohm \pm 1%, 2W, deposited carbon	Aerovox CP-2-3 meg. \pm 1%

Reference Designation	Description	Mfr's Type No.
R606	Resistor, Fixed, Composition: 10,000 ohm, \pm 10%, 1W	Allen Bradley GB1031
SW601	Switch, Sensitive: rated 15 amp at 125 VAC, 10 amp at 250 VAC, plunger act.	Micro Switch EZ-2RQ104
SW602	Switch, Pressure	REL C-AS-30-0A
TB601	Terminal Board: 8 single screw and Feed thru terminals, barrier type	General Prod. 441-Y-8
TB602	Terminal Board: 13 single screw and feedthru terminals, barrier type	General Prod. 441-Y-13
TB603	Terminal Board: 4 double screw terminal	General Prod. 441-4
V601	Electron Tube	Amperex 4X250B
V602	Electron Tube	VR150
V603	Electron Tube	VR105
XV601	Socket, Electron Tube: Air system type, contains screen by-pass capacitor, used with 4X250 tube	Eimac SK-600
XV602	Socket, Electron Tube: 8 contacts	TS101P01 JAN-S-28A
XV603	Socket, Electron Tube:	
1	Switch, Sensitive: Rotary Type; 5 amp at 125V or 250 VAC (part of S602)	Micro Switch V4-14

H. Type S-1799 METER PANEL

Reference Designation	Description	Mfr's Type No.
C850	Capacitor, Fixed, Ceramic Dielectric: 0.01 uf, GMV, 600V, disc.	Radio Materials Co B-0.01-600V
C851	Same as C850	
C852	Same as C850	
M801	Ammeter: 0-300 MA DC; self contained, scale to be entitled "Milliamperes Plate". Black face with white markings	Simpson Model 29
M802	Voltmeter: 0-1 MA DC movement; 0-3 KV scale entitled "Kilovolts Plate"; Black face with white markings	Simpson Model 29
M803	Wattmeter: 0-200 micro amp DC move- ment; scale entitled "Watts R.F. Power", black face with white markings	Simpson Model 29
TB806	Terminal Board: solid black, molded black phenolic; 8 double screw terminals, barrier type.	General Prod. 440-8