

*Laboratory
Standards*

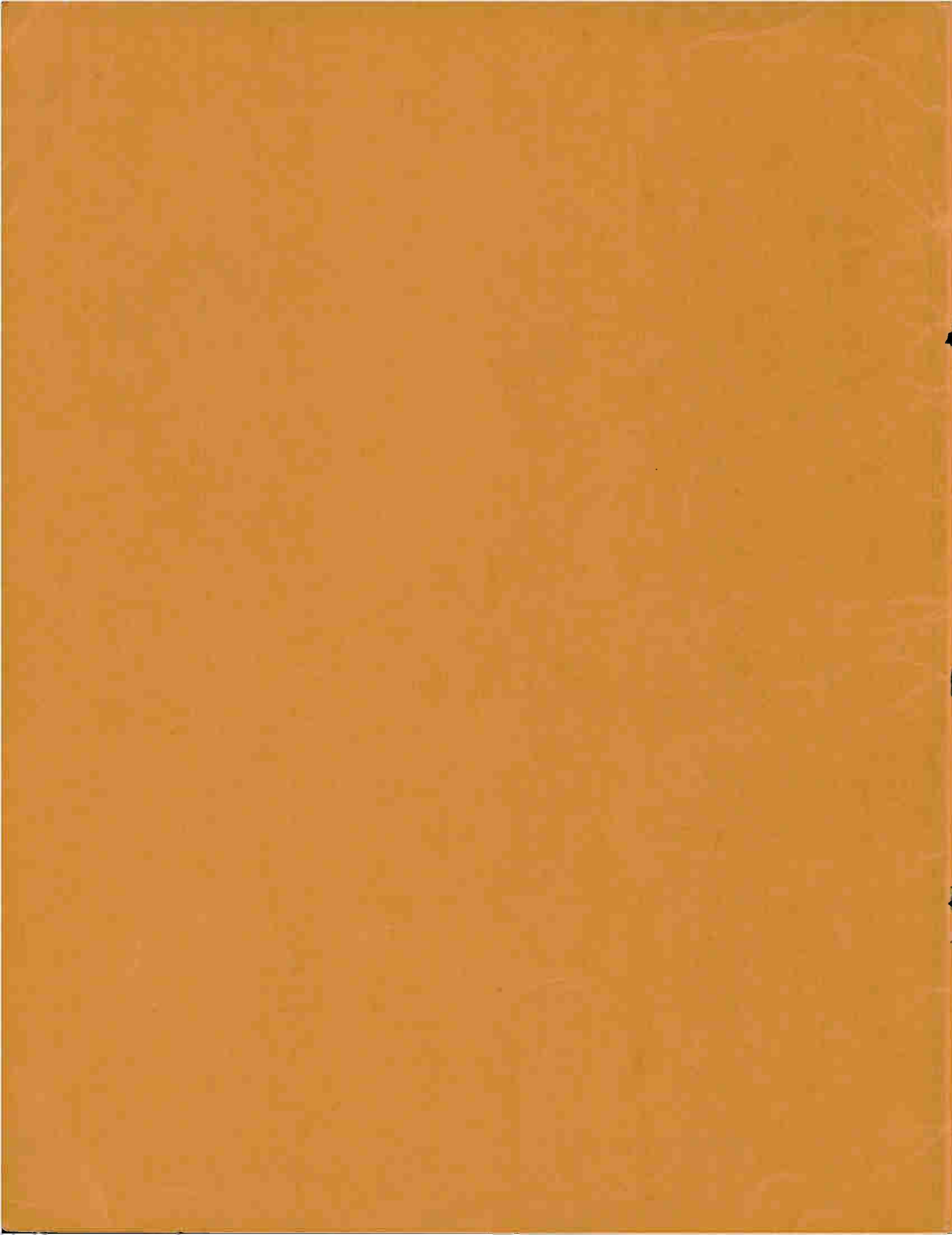



Laboratory Standards

PRICE LIST INSTRUMENTS

MODEL NUMBER	DESCRIPTION	CATALOG PAGE NO.	PRICE
58	U. H. F. RADIO NOISE & FIELD STRENGTH METER	27	\$ 925.00
59	MEGACYCLE METER	33	PRICE \$168.00 185.00
62	VACUUM TUBE VOLTMETER	29	135.00
62 UHF SPECIAL	VACUUM TUBE VOLTMETER	29	185.00
65-B	STANDARD SIGNAL GENERATOR	9	875.00
67	PEAK-TO-PEAK VOLTMETER	31	235.00
71	SQUARE WAVE GENERATOR	25	195.00
78-B	STANDARD SIGNAL GENERATOR	11	310.00
78-C	STANDARD SIGNAL GENERATOR	11	310.00
78-E	STANDARD SIGNAL GENERATOR	11	275.00
78-F	STANDARD SIGNAL GENERATOR	11	325.00
78-FM	STANDARD SIGNAL GENERATOR	13	375.00
78-FM SPECIAL	STANDARD SIGNAL GENERATOR	13	425.00
79-B	PULSE GENERATOR	23	295.00
80	STANDARD SIGNAL GENERATOR	17	590.00
82	STANDARD SIGNAL GENERATOR	7	660.00
84	STANDARD SIGNAL GENERATOR	21	1950.00
90	TELEVISION STANDARD SIGNAL GENERATOR	19	7460.00
183-B	MEGOHM METER	36	125.00
M-234	R. F. ATTENUATOR	36	75.00
M-235	R. F. ATTENUATOR	36	115.00
M-275	I. F. CONVERTER	15	178.00
31	INTERMODULATION METER		220.00
111	CRYSTAL CALIBRATOR		97.50
112	U.H.F. OSCILLATOR		575.00

See Other Side For Accessory Prices

The Above Prices Subject To Change Without Notice.

All Prices F. O. B.

Boonton, N. J.

TERMS: 1% 10 Days, Net 30

Subject to Credit Dept. Approval

MEASUREMENTS

CORPORATION

BOONTON



NEW JERSEY

Laboratory Standards

PRICE LIST ACCESSORIES

FOR USE WITH	PART NO.	DESCRIPTION	CATALOG PAGE NO.	PRICE
MODEL 80	80-ZH1	MATCHING PAD	38	\$ 15.00
	80-ZH3	MATCHING PAD	38	15.00
	80-ZH4	OUTPUT CABLE	38	15.00
	84-Z2-1	OUTPUT CABLE	38	10.00
	84-Z2-2	OUTPUT CABLE	38	10.00
	84-Z2-3	OUTPUT CABLE	38	10.00
	UG-201/U	ADAPTER	38	3.25
	M-255	MATCHING PAD	38	25.00
	M-266	OUTPUT CABLE	38	10.00
	M-286	IMPEDANCE MATCHING TRANSFORMER	38	15.50
MODEL 84	84-Z2-1	OUTPUT CABLE	38	10.00
	84-Z2-2	OUTPUT CABLE	38	10.00
	84-Z2-3	OUTPUT CABLE	38	10.00
MODEL 65-B	B-1155	OUTPUT CABLE	10	7.50
MODEL 58	A-112	ANTENNA CABLE	39	17.50
	A-110	LOOP PROBE ANTENNA	39	15.00
	A-107	AC CABLE	39	8.00
	A-108	BATTERY CABLE	39	15.00
	58-Z12	HIGH IMPEDANCE PROBE COMPLETE KIT WITH ACCESSORIES AND CASE, LISTED BELOW	39	48.00
	A-220-1-2	DOUBLET ANTENNAS (Including Holder A-215)	39	115.00
	A-1108	TRIPOD & STAND	39	40.00
	A-1165-1-2-3	TRIPOD & STAND	39	17.50
	A-211	LOOP PROBE ANTENNA	39	12.00
	A-212	CAPACITY PROBE	39	8.00
	A-213	ANTENNA CONNECTOR	39	15.00
	157	TRIMM HEADPHONES	39	16.00
	B-217	ACCESSORY CASE	39	15.00
MODEL 62	A-2117	PROBE	29	12.00
MODEL 62 UHF	A-2124	PROBE Not Interchangeable with A-2117 Probe	29	35.00

See Other Side For Instrument Prices.

The Above Prices Subject To Change Without Notice.

All Prices F. O. B.
Boonton, N. J.

TERMS: 1% 10 Days, Net 30
Subject to Credit Dept. Approval

MEASUREMENTS

CORPORATION

BOONTON



NEW JERSEY

CRYSTAL CALIBRATOR

Model 111

*An Extremely Accurate Instrument
For The Frequency Calibration Of
Equipment In The Range Of—*

250 Kc. to 1000 Mc.

FREQUENCY ACCURACY $\pm 0.002\%$

The Model 111 was designed as a dual-purpose calibrator. It not only provides a test signal of crystal-controlled frequency, but also has a self-contained receiver with a sensitivity of 2 microwatts.

A new circuit arrangement utilizes the cross-modulation products of three separate oscillators operating at the fundamental frequencies of .25, 1.0 and 10 megacycles. This system extends the usable range of harmonic frequencies far beyond that of previously available equipment.

DESIGNED FOR THE CALIBRATION AND FREQUENCY CHECKING OF —

- Signal Generators
- Transmitters
- Receivers
- Grid-Dip Meters

And other equipment where a high degree of frequency accuracy is required.

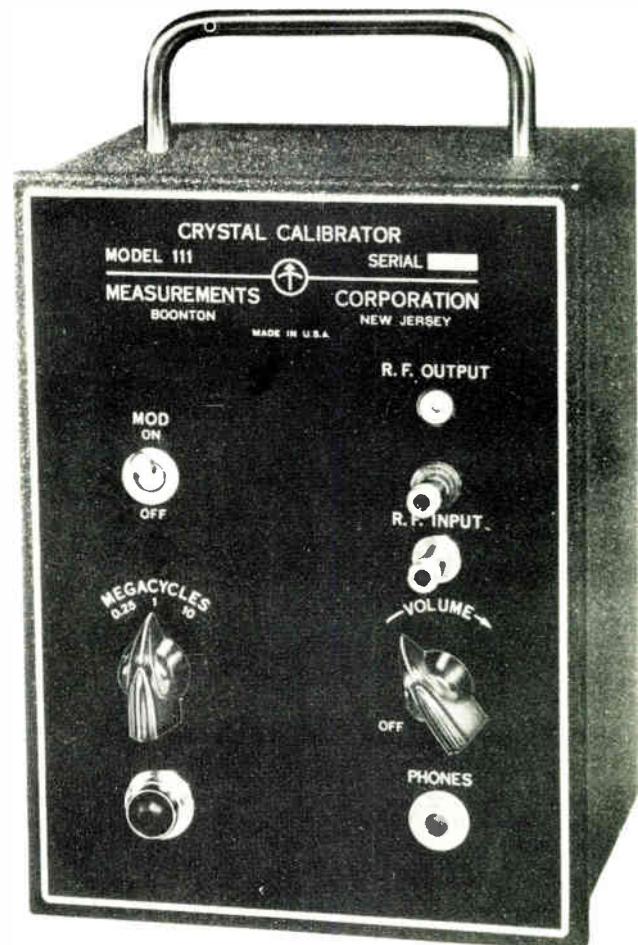

SPECIFICATIONS:

FREQUENCY RANGE:	.25 to 1000 Megacycles
HARMONIC RANGE:	.25 Mc. Oscillator: .25-450 Mc. 1 Mc. Oscillator: 1-600 Mc. 10 Mc. Oscillator: 10-1000 Mc.
FREQUENCY ACCURACY:	$\pm 0.002\%$
POWER SUPPLY:	117 volts, 50/60 cycles; 18 watts.
DIMENSIONS:	6" wide, 8" high, 5" deep.
WEIGHT:	4 lbs.

MEASUREMENTS

BOONTON



CORPORATION

NEW JERSEY

Laboratory Standards

FOR PRECISION MEASUREMENTS
5 CYCLES TO



IN THE FREQUENCY RANGE OF
1000 MEGACYCLES



MODEL 59 MEGACYCLE METER
2.2 to 400 megacycles in seven coil ranges

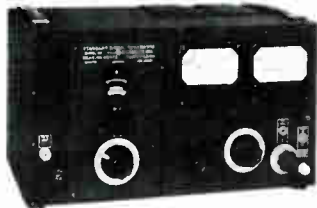

MODEL 80 STANDARD SIGNAL GENERATOR
2 to 400 megacycles, AM and Pulse Modulation



MODEL 65-B STANDARD SIGNAL GENERATOR
75 to 30,000 kilocycles M.O.F.A., 100% Modulation



MODEL 82 STANDARD SIGNAL GENERATOR
20 cycles to 50 megacycles, AM



MODEL 62 VACUUM TUBE VOLTMETER
0 to 100 volts AC, DC and RF



MODEL 84 U.H.F. STANDARD SIGNAL GENERATOR
300 to 1000 megacycles, AM and Pulse Modulation

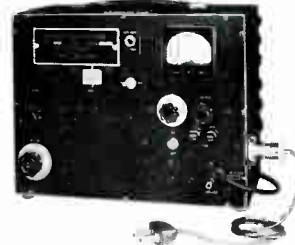

MODEL 78-FM STANDARD SIGNAL GENERATOR
86 to 108 megacycles, 0 to 300 KC. deviation

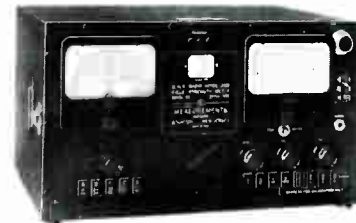

MODEL 58 U.H.F. RADIO NOISE AND FIELD STRENGTH METER 15 to 150 megacycles



MODEL 79-B PULSE GENERATOR
60 to 100,000 cycles 0.5 to 40 microsecond pulse width



MODEL 71 SQUARE WAVE GENERATOR
5 to 100,000 cycles

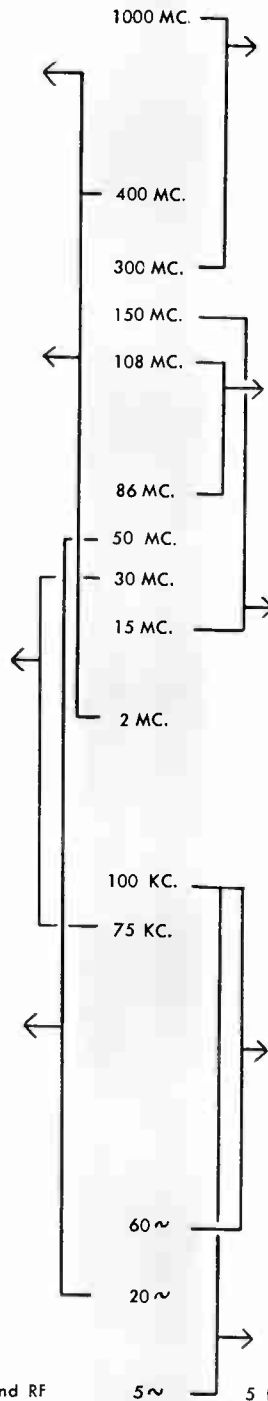

MEASUREMENTS CORPORATION

BOONTON · NEW JERSEY

INTERMODULATION DISTORTION

Its Causes, Effects and Measurement

THE measurement of intermodulation distortion is becoming of increasing importance in the evaluation of audio frequency equipment, but has not been widely adopted due to a lack of low cost, direct-reading equipment and the tedious procedures necessary with conventional instruments.

Broadly defined, intermodulation distortion is the effect produced when two or more different frequencies are applied to a non-linear network. The output from the network will contain, in addition to the original frequencies and their harmonics, new frequencies equal to the sum and difference of the original frequencies. This effect has been employed to advantage for many years in superheterodyne receivers, beat frequency oscillators and amplitude modulation, but its presence in audio equipment is highly undesirable. This is due to the fact that many audio signals, and music in particular, contain many frequencies that are harmoniously, as well as harmonically related. Intermodulation creates new frequencies that have no harmonious relationship to the original tones and in the case of musical programs the reproduced music has a harsh discordant quality that is extremely disagreeable to the listener. While no definite stand-

ards have been set establishing the amount of intermodulation distortion acceptable to the human ear, many experts agree that no more than 5% is permissible in a high quality system. Lesser percentages may pass unnoticed audibly, yet express themselves by increasing fatigue on the part of the listener.

In years past it was the custom to evaluate audio equipment on the basis of the percentage of harmonics generated by a single frequency, usually 400 or 1000 cycles. It has been demonstrated that the amount of harmonic distortion and the amount of intermodulation distortion bear a definite predictable relationship, if the type and degree of non-linearity are known. However, many things, including vacuum tubes, transformers, phonograph pickups, etc., may contribute to the non-linearity of a system and as the degree of non-linearity which they introduce is often a function of frequency, intermodulation measurements will often give an entirely different and much more unfavorable answer than that given by a single frequency harmonic analysis. It is interesting to note that critical listening tests usually confirm the results to be expected from intermodulation measurements.



INTERMODULATION METER—Model 31

FEATURES:

- A compact, completely self-contained unit with—
Test Signal Generator
Analyzer
Voltmeter
Power Supply
- Direct-reading meter indicates percentage of intermodulation.
- Accurate metering of input voltage to analyzer.
- Easy to operate.
- Quick, accurate measurements.
- May be mounted in standard 19" relay rack. (7" relay rack panel space).
- Connection for oscilloscope.

APPLICATIONS:

- Insuring peak performance from all audio systems.
- Correct adjustment and maintenance of AM and FM receivers and transmitters.
- Checking linearity of film and disc recordings and reproductions.
- Checking phonograph pick-ups and recording styli.
- Checking record matrices.
- Adjusting bias in tape recordings.
- For quality control of all audio components and equipment.

SPECIFICATIONS

GENERATOR

LOW FREQUENCY: 60 cycles.

HIGH FREQUENCY: 3000 cycles.

LF/HF VOLTAGE RATIO: Fixed 4/1.

OUTPUT VOLTAGE: 10 v. max. into high impedance
or +5 DBM matched to 600 ohms.

OUTPUT IMPEDANCE: 2000 ohms.

RESIDUAL INTERMODULATION: 0.2% max.

ANALYZER

INPUT VOLTAGE: Full scale ranges of 3, 10 and 30
volts RMS. Less than one volt of mixed signal is
sufficient for operation.

INPUT IMPEDANCE: Greater than 400 K ohms.

INTERMODULATION: Full scale ranges of 3, 10
and 30%.

ACCURACY: $\pm 10\%$ of full scale.

GENERAL: Power Supply 117 volts, 50/60 cycles. 30
watts. Dimensions: 8" high x 19" wide x 9" deep.
Weight 16 lbs. Tubes: 1-12AX7, 1-12AT7,
1-6J5GT, 1-5Y3GT.

MODEL 30 INTERMODULATION METER

This model has a test generator providing: a
low frequency range of 40, 70 and 100 cycles;
a high frequency range of 2000, 7000 and 12,000
cycles, either separate or mixed in a 1/1 or 4/1
ratio.

The analyzer will operate from 20 cycles to
200 cycles and from 2000 cycles to 20,000 cycles.

A direct-reading meter measures intermodula-
tion percentages from 0.1% to 30%; test gen-
erator output voltages from .01 to 100 v. (-30
to $+20$ DBM); analyzer input voltages from
.0001 to 100v. (-70 to $+40$ DBM).

MEASUREMENTS

BOONTON



CORPORATION

NEW JERSEY

MEASUREMENTS CORPORATION

BOONTON · NEW JERSEY · U·S·A·

RESEARCH AND MANUFACTURING ENGINEERS

of

PULSE GENERATORS

SQUARE WAVE GENERATORS

STANDARD SIGNAL GENERATORS

TELEVISION SIGNAL GENERATORS

U.H.F. RADIO NOISE & FIELD STRENGTH METERS

MEGOHM METERS

PEAK VOLTMETERS

R.F. ATTENUATORS

MEGACYCLE METERS

INDUCTANCE BRIDGES

CAPACITANCE BRIDGES

VACUUM TUBE VOLTMETERS

SPECIAL TEST INSTRUMENTS

Laboratory



Standards

DEVELOPMENT ENGINEERING

THE production of a precision line of electronic instruments requires extensive laboratory facilities for months, even years, of research work. Special equipment must be designed, new techniques devised and a thorough study of the specific application of the instrument being developed must be made.

Our Engineering Laboratory, through years of careful planning and an accumulation of the finest instruments, is prepared for any engineering detail within the scope of the profession.

Such facilities, however, would be worthless without the expert engineering personnel that has made our company's instruments outstanding leaders in the measurements field.

Our staff of engineers, many of them pioneers in electronic research, are ready with the technical knowledge required to approach and satisfactorily solve any problem that may be presented to us.

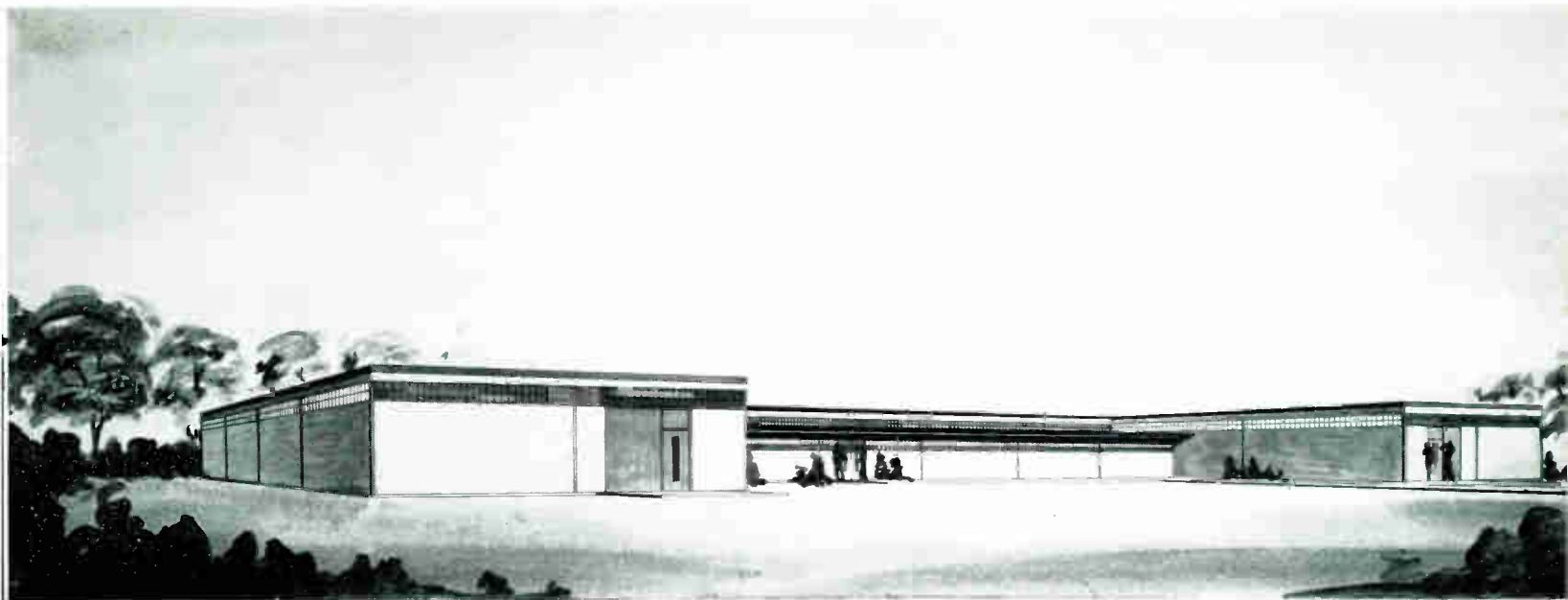

The New Home of Measurements Corporation

SINCE the founding of this company, we have specialized in the development and production of laboratory standards designed for radio, television and many other fields of electronic engineering and manufacturing. It has been our aim to not only make available those instruments currently required by laboratories and industry, but to anticipate the future needs of the art.

This policy has enabled us to be the first to commercially produce such instruments as the pulse generator; a UHF signal generator with built-in pulse modulation; an FM signal generator for the present channels; a television standard signal generator as well as many other innovations in electronic measuring equipment.

Rigid engineering control of all phases of manufacturing, from the selection of component parts, through the production departments, to the final mechanical and electrical inspection, assure every customer of quality instruments that are guaranteed to give accurate, dependable service.

MEASUREMENTS  CORPORATION
BOONTON NEW JERSEY

TABLE OF CONTENTS

STANDARD SIGNAL GENERATORS				
MODEL	PAGE	FREQUENCY RANGE	OUTPUT RANGE	MODULATION
65-B	9	75 Kc.-30 Mc.	0.1 microvolt to 2.2 volts	AM. 0 to 100% 400 cycles or 1000 cycles External mod., 50-10,000 cycles
78	11	15-25 Mc.; 195-225 Mc. 15-25 Mc.; 90-125 Mc. other ranges on order	1 to 100,000 microvolts	AM. 8200-400 cycles 625-400 cycles Fixed at approximately 30%
78-FM	13	86 Mc.-108 Mc.	1 to 100,000 microvolts	Deviation 0-300 kc, 2 ranges FM. 400-8200 cycles External modulation to 15 Kc.
80	17	2 Mc.-400 Mc.	0.1 to 100,000 microvolts	AM. 0 to 30% 400 cycles or 1000 cycles External mod., 50-10,000 cycles.
Accessories	38			
82	7	20 cycles to 200 Kc. 80 Kc. to 50 Mc.	0-50 volts 0.1 microvolt to 1 volt	Continuously variable 0-50% from 20 cycles to 20 Kc.
84	21	300 Mc.-1000 Mc.	0.1 to 100,000 microvolts	AM. 0 to 30%, 400, 1000, or 2500 cycles. Internal pulse modulator. External mod., 50-30,000 cycles.
90	19	20 Mc.-250 Mc.	0.3 microvolt to 0.1 volt	Continuously variable, 0 to 100% Sinusoidal modulation 30 cycles— 5 Mc. Composite TV modulation.
Accessories	40			
PULSE GENERATOR				
MODEL	PAGE	FREQUENCY RANGE	PULSE WIDTH	OUTPUT
79-B	23	60 to 100,000 cycles	Continuously variable from 0.5 to 40 microseconds	Approximately 150 volts positive with respect to ground. "Sync Output" 75 volts positive with respect to ground.
SQUARE WAVE GENERATOR				
MODEL	PAGE	FREQUENCY RANGE	WAVE SHAPE	OUTPUT
71	25	Continuously variable 6 to 100,000 cycles	Rise time less than 0.2 microseconds with negligible overshoot	Step attenuator: 75, 50, 25, 15, 10, 5 peak volts fixed and 0 to 2.5 volts continuously variable.
U.H.F. RADIO NOISE and FIELD STRENGTH METER				
MODEL	PAGE	FREQUENCY RANGE	INPUT VOLTAGE RANGE	
58	27	15 Mc. to 150 Mc.	1 to 100,000 microvolts in antenna. 1 to 100 microvolts on semi-logarithmic output meter, balanced resistance attenu- ator with ratios of 10, 100 and 1000 ahead of all tubes.	
Accessories	39			



TABLE OF CONTENTS — (Continued)

VACUUM TUBE VOLTMETERS				
MODEL	PAGE	VOLTAGE RANGE	FREQUENCY RANGE	INPUT IMPEDANCE
62	29	0-1, 0-3, 0-30 and 0-100 volts AC or DC	30 cycles to over 150 Mc.	Approximately 7 mmfd.
62-U.H.F.	29	0-1, 0-3, 0-30 and 0-100 volts AC or DC	100 Kc. to 500 Mc.	Approximately 2 mmfd.
67	31	.0005 to 300 volts peak-to-peak	5 to 100,000 sine-wave cycles per second	1 megohm shunted by 30 mmfd.
MEGACYCLE METER				
MODEL	PAGE	FREQUENCY RANGE	FREQUENCY ACCURACY	MODULATION
59	33	2.2 Mc. to 4 Mc.	Within $\pm 2\%$	CW or 120 cycles fixed at ap- proximately 30%. Provision for external modulation
I. F. CONVERTER				
MODEL	PAGE	FREQUENCY	OUTPUT	MODULATION
M-275	15	4.5 Mc., 10.7 Mc., 21.7 Mc.	10 microvolts to 1.0 volt when used with Model 78-FM	Up to approximately 80% AM combined with or exclusive of FM.
R. F. ATTENUATORS				
MODEL	PAGE	FREQUENCY RANGE	OUTPUT RANGE	OUTPUT IMPEDANCE
M-234	36	2 Mc.-1000 Mc.	0.3 to 100,000 microvolts	Matched 50 ohm line
M-235	36	2 Mc.-300 Mc.	0.3 to 100,000 microvolts	Matched 100 ohms line to line or 50 ohms to ground.
MEGOHM METER				
MODEL	PAGE	RESISTANCE RANGE	ACCURACY	
183-B	36	300 to 100,000 megohms	Within $\pm 5\%$	
BRIDGES				
MODEL	PAGE	INDUCTANCE (L)	CAPACITANCE (C)	AC RESISTANCE (R)
102	37	0.5 microhenry to 110 henries	1 mmf. to 110 mfd. Power factor 0-30%	1 ohm to 11 megohms
101	37		From 0.1 mmfd. to 1 mfd. in five ranges Power factors from 0.1% to 10%	





EVERY effort has been made to include the complete specifications of all instruments shown in this catalog.

We invite inquiries regarding the application and maintenance of this equipment as well as suggested modifications for special requirements.

MEASUREMENTS CORPORATION

BOONTON • NEW JERSEY

See Pages 42 and 43 for: "The Importance of Matched Impedances in Signal Generator Measurements"

No part of this catalog may be reproduced in whole or in part except by permission of Measurements Corporation

•

Copyright 1949 by Measurements Corporation

•

Printed in U.S.A.

STANDARD SIGNAL GENERATOR—Model 82

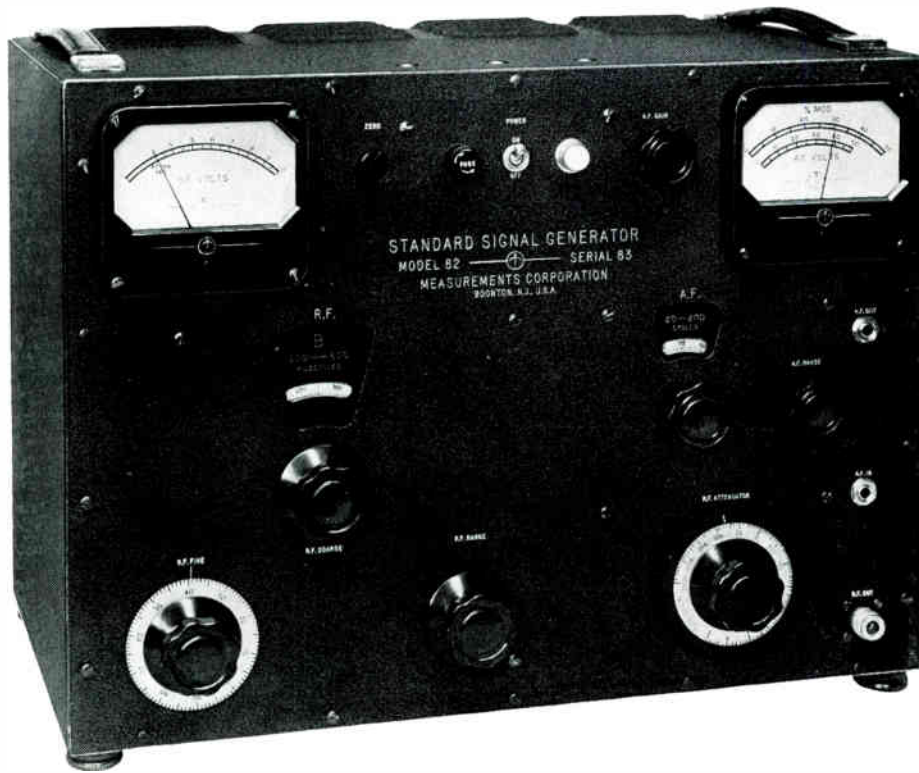

THE Model 82 Standard Signal Generator provides extremely wide frequency coverage. This instrument comprises a low frequency oscillator covering the range from 20 cycles to 200 kilocycles and a radio frequency oscillator in the 30 kilocycle to 50 megacycle range. As both oscillators have low harmonic output, the Model 82 can be used to measure the complete amplitude response of video amplifiers as well as for many other applications.

The low frequency oscillator not only provides an output of from 0 to 50 volts, but may be used to amplitude modulate the radio frequency oscillator. Thus, this one instrument is sufficient for checking the RF, IF and AF performance of receivers.

With the radio frequency oscillator, measurements from 0.1 microvolt to 1 volt across 50 ohms can be made. The output level from the mutual inductance type attenuator is continuously monitored, and triple shielding is used to reduce leakage and stray fields to a minimum.

High level measurements, with voltages up to 50 volts can be made with the Model 82 low frequency oscillator.

External attenuators are available for providing a 1.5 volt, peak-to-peak, video signal across 75 ohms, or much lower microvoltages for low frequency RF and IF measurements.

FEATURES:

- Continuous range from 20 cycles to 50 megacycles in one instrument.
- Individually calibrated dials.
- Low harmonic output.
- Accurately metered output.
- Stray field and leakage less than 1 microvolt.
- Built-in power supply.

USES:

For audio and radio frequency measurements of AM, FM and television receivers. For testing and checking the frequency response of audio systems; as a driving source for AF and RF bridges; for testing video and wide-band amplifiers.

STANDARD SIGNAL GENERATOR—Model 82

SPECIFICATIONS:

Frequency Range: 20 cycles to 200 kilocycles in four ranges. 80 kilocycles to 50 megacycles in seven ranges, plus one blank range.

Frequency Calibration: Each range is individually calibrated. 20 cycles to 200 kilocycles, accurate to $\pm 5\%$. 80 kilocycles to 50 megacycles, accurate to $\pm 1\%$.

Output Voltage and Impedance: 0.50 volts across 7500 ohms from 20 cycles to 200 kilocycles. The output voltage and impedance in this range can be reduced by external attenuator. 0.1 microvolt to 1 volt across 50 ohms over most of the range from 80 kilocycles to 50 megacycles.

Modulation: Continuously variable from 0.50% from 20 cycles to 20 kilocycles from internal variable oscillator or external source.

Harmonic Output: Less than 1% from 20 cycles to 20 kilocycles; 3% or less from 20 kilocycles to 50 megacycles.

Leakage and Stray Field: Less than 1 microvolt from 80 kilocycles to 50 megacycles.

Power Supply: 117 volts. 50-60 cycles. 75 watts.

Step-down transformer available for 220 volts, 50 cycle operation.

Dimensions: 15" high x 19" wide x 12" deep overall.

Weight: 50 lbs.

Tubes: 1—5Y3GT
1—6Y6G
1—6AG7
1—6SJ7
1—OC3/VR105
1—6J7
1—6V6GT
2—6AL5
1—6C4

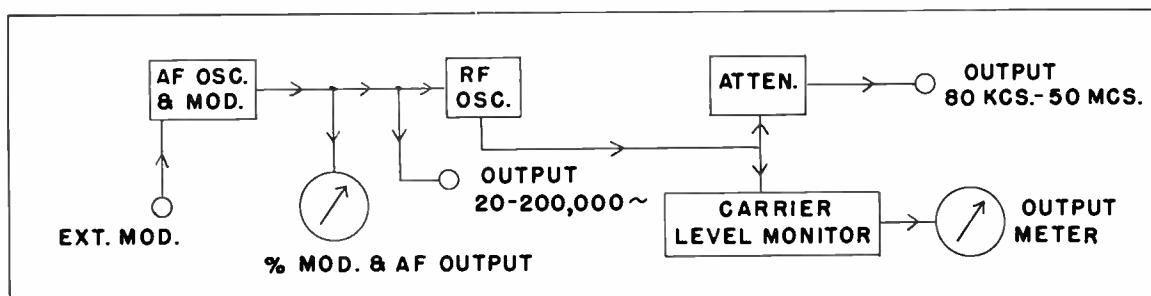

MODEL 82 BLOCK DIAGRAM



STANDARD SIGNAL GENERATOR—Model 65-B



FOR laboratory use or in production testing, where ultimate accuracy and simplicity of operation is essential, the Model 65-B will meet the most exacting requirements. Its acceptance by engineers in all phases of electronics testifies to the soundness of design, and precision in manufacturing, of this fine instrument.

The circuit of the Model 65-B is of the master-oscillator, tuned power-amplifier type. 100% modulation of the amplifier results in lower distortion and a practically constant output over each of the six tuning ranges. An internal audio oscillator provides modulating frequencies of 400 or 1000 cycles.

This signal generator has an individually calibrated direct-reading frequency dial with a 2300 division linear scale; it is motor driven for rapid operation.

A vacuum tube voltmeter output meter with an expanded scale characteristic makes possible a continuous indication of output with maximum accuracy from 0.1 microvolt to 2.2 volts. Complete internal shielding and careful filtering hold the leakage below 0.1 microvolt.

The Model 65-B, completely self-contained with modulator and power supply, can be used for a wide range of applications where a standard of accuracy is required.

FEATURES:

- Direct reading scales and dials; individually calibrated.
- Easily adjusted carrier frequency, modulation frequency, modulation depth and output voltage amplitude.
- Built-in power supply and modulator.
- Internal shielding makes residual voltage and leakage negligible.

USES:

The Model 65-B provides accurate test signals for the measurement of the sensitivity, selectivity, fidelity, overload, distortion, automatic gain control, image and intermediate frequency rejection ratios, noise and stage gain characteristics.

STANDARD SIGNAL GENERATOR—Model 65-B

SPECIFICATIONS:

Frequency Range: 75 kilocycles to 30 megacycles in 6 push-button ranges.

Frequency Accuracy: Individually calibrated dial direct reading to an accuracy of $\pm 0.5\%$. Backlash less than 1 part in 2300.

Output Voltage: Continuously variable from 0.1 microvolt to 2.2 volts.

Output System: Without cable connected, the impedance at the panel jack is 6.0 ohms plus internal lead and contact resistance. With 30 ohm cable (furnished with instrument) output impedance is 5 ohms to 0.2 volt. rising to 15 ohms at 2.2 volts.

Output Voltage Calibration: Accuracy at 1 volt $\pm 4\%$ between 1 megacycle and 25 megacycles.

Accuracy of Fixed Attenuator Steps: $\pm 5\%$ except for the 1-0.1 step which is -9% to $+2\%$.

Modulation: Continuously variable from 0 to 100%, indicated directly by a panel meter. Modulation may be obtained either from an internal source of 400 or 1000 cycles (within $\pm 5\%$) or from an external source.

Envelope Distortion: 4% at 100% modulation at 1 megacycle. 8% at 100% modulation at 15 megacycles. 1% at 30% modulation.

Frequency Modulation: Less than 0.02% for 30% amplitude modulation.

Leakage: Less than 0.1 microvolt leakage with attenuator set for 0 output.

Power Supply: 117 volts 50-60 cycles. 115 watts. Step-down transformer available for 220 volts, 50 cycle operation.

Dimensions: 11" high x 20" wide x 10 $\frac{1}{4}$ " deep, overall.

Weight: Approximately 55 pounds.

Tubes: 2—6SJ7 or 6SJ7GT

1—6L6

1—6SK7 (ceramic base)

1—6V6 or 6V6GT

1—5T4

2—6H6

1—6AG7

2—OD3/VR150

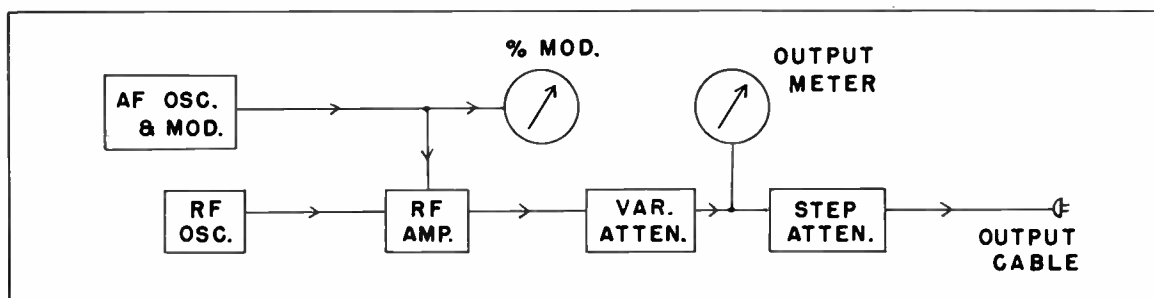

MODEL 65-B BLOCK DIAGRAM



STANDARD SIGNAL GENERATOR—Model 78

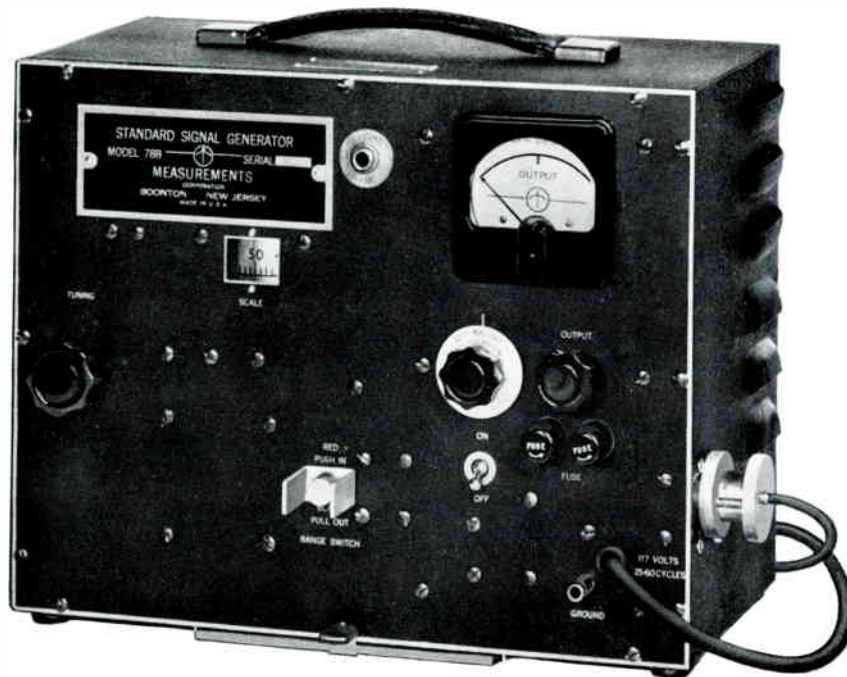

THE Model 78 series provides a wide selection of carrier and modulation frequencies for special laboratory work, production testing and field use. Though small in size, careful design and choice of component parts have made it possible to produce a moderately-priced instrument that is accurate and dependable.

These generators use a 9002 tube in a stable Colpitts-type oscillator circuit; a splitstator tuning condenser simplifies operation of the circuit by eliminating moving parts which might cause noise as the frequency is varied. This condenser is driven by a combined planetary and cord drive resulting in a reduction ratio of approximately 20:1; the frequency scale is on a drum which rotates with the tuning condenser.

A mutual inductance attenuator is calibrated directly in microvolts across the binding posts at the end of the output cable. The output is indicated on the scale engraved on the sliding tube of the attenuator. This tube pulled out to the maximum decreases the output to 1 microvolt. Push-

ing the tube in gradually increases the output to 100,000 microvolts.

Careful filtering of the power leads and complete shielding of the instrument reduce stray fields and leakage to a minimum.

FEATURES:

- Compactly designed for portability.
- Wide selection of carrier and modulation frequencies on special order.
- Built-in power supply and modulator.
- Dependable mutual inductance attenuator.

USES:

For special applications where a wide range of frequencies is not required, the signal generators in the Model 78 series will give reliable service and a high degree of accuracy.



STANDARD SIGNAL GENERATOR—Model 78

SPECIFICATIONS:

Frequency Range: Model 78-B, 15 to 25 megacycles and 195 to 225 megacycles. Model 78-C, 15 to 25 megacycles and 90 to 125 megacycles. Special instruments supplied on order within the range of 10 to 250 megacycles with a choice of two bands each having a 1.8 to 1 frequency ratio. Special one band instruments supplied covering the range of 100 to 275 megacycles or 250 to 420 megacycles.

Output Voltage: Continuously variable from 1 microvolt to 100,000 microvolts.

Output System: Mutual inductance attenuator calibrated directly in microvolts.

Output Impedance: 35 ohms across binding posts of output cable furnished with instrument.

Leakage: Less than 1 microvolt.

Modulation: Amplitude modulation fixed at approximately 30%. Modulation frequencies for Model 78-B, 8200 and 400 cycles. For the Model 78-C, 625 and 400 cycles. A switch is provided for turning modulation off. Special modulation frequencies available on order.

Power Supply: 117 volts, 25 to 60 cycles. 35 watts.

Dimensions: 10" high x 13" wide x 7" deep, overall.

Weight: Approximately 22 pounds.

Tubes: 1—9002

1—7Y4

1—OD3/VR150

1—7L7

1—7C5

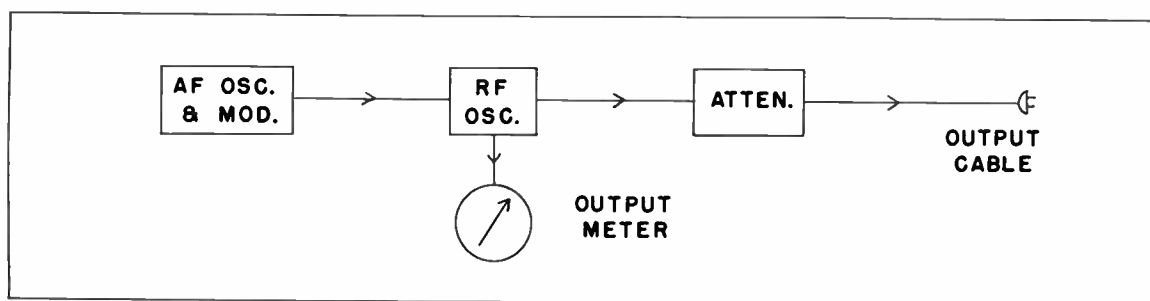

MODEL 78B BLOCK DIAGRAM



STANDARD FM SIGNAL GENERATOR—Model 78-FM



LABORATORIES, radio manufacturers and radio service organizations requiring an accurate FM signal generator for measurements in the range from 86 to 108 megacycles have found the Model 78FM most satisfactory. Its convenient size, moderate cost and reliability of operation has made the instrument very adaptable to production testing operations where a large number of units are required.

Unlike other types of FM generators, the Model 78FM employs no beat frequency oscillators, thus no spurious components, other than small amounts of simple carrier harmonics, are present in its output.

A mutual inductance type attenuator is calibrated directly in microvolts across the binding posts at the end of the output cable. The shielding and filtering of the Model 78FM is adequate for measurements down to one microvolt as leakage is of a negligible value. The noise level from all sources is at least 65 db below that of the desired signal output.

The Model 78FM when used in conjunction with the

Model M-275 I.F. Converter will provide output in the I.F. ranges of 4.5 Mc., 10.7 Mc. and 21.7 Mc.

Special one-band Model 78FM Signal Generators, with a tuning ratio of approximately 1.2 to 1, are available for use within the limits of 30 to 165 megacycles.

FEATURES:

- Carrier range on fundamentals; beat-frequency method not used.
- Individually calibrated carrier frequency and carrier frequency deviation dials.
- Built-in power supply and modulator.
- Internal shielding holds residual voltage and leakage to negligible value.

USES:

Designed for FM research, development and production testing to provide output measurements of satisfactory accuracy and extremely low distortion.



STANDARD FM SIGNAL GENERATOR—Model 78-FM

SPECIFICATIONS:

Frequency Range: 86 to 108 megacycles.

Frequency Accuracy: Individually calibrated dial, direct reading to an accuracy of $\pm 0.5\%$.

Output Voltage: Continuously variable from 1 to 100,000 microvolts.

Output System: Mutual inductance attenuator with 35 ohm output coaxial cable terminated in its surge impedance.

Leakage: Less than 1 microvolt.

Modulation: 400 cycle internal audio oscillator. Can be modulated from an external source providing 6 volts across 5000 ohms.

Frequency Modulation Deviation Range: Continuously variable from 0 to 300 kilocycles in two ranges: 0-30

kilocycles and 0-300 kilocycles, indicated on directly calibrated dial.

Fidelity: Flat within two db from d.c. to 15,000 cycles. Distortion is less than 1% at 75 kilocycles deviation. Transient response is excellent.

Power Supply: 117 volts, 50 to 60 cycles, 36 watts.

Step-down transformer available for 220 volts, 50 cycle operation.

Dimensions: 10" high x 13" wide x 7" deep, overall.

Weight: Approximately 25 pounds.

Tubes: 1—9002
2—6AK5
1—7Y4
1—OD3/VR150
1—7L7
1—7C5

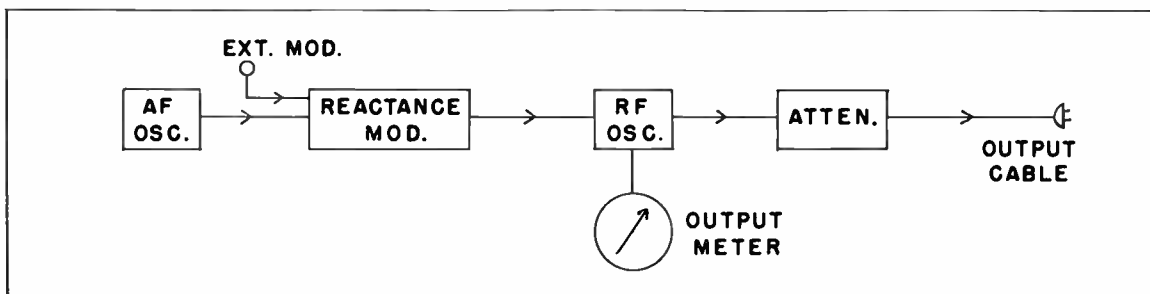

MODEL 78-FM BLOCK DIAGRAM



INTERMEDIATE FREQUENCY CONVERTER—Model M-275

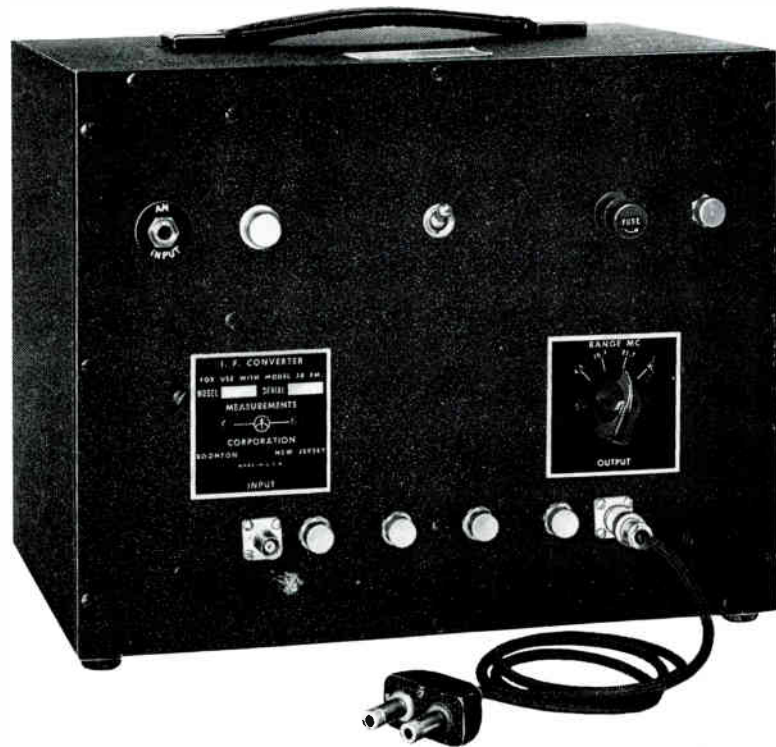

THE Model M-275 I.F. Converter was designed to be used with the Model 78-FM Standard Signal Generator to provide carrier output frequencies in the FM and Television receiver I.F. ranges.

A local oscillator in the M-275 beats with the proper frequency from the Model 78-FM to produce the desired output frequency. Spurious frequencies are kept at a minimum and none are present within the output carrier ranges.

Provision is made in the M-275 for amplitude modulation of the I.F. carrier for checking proper discrimination against AM by limiters and ratio detectors.

Users of the Model 78-FM can effect the modification of the instrument for use with the Model M-275 I.F. Converter as all changes are external and do not require the Model 78-FM to be removed from its case. The conversion is very simple and requires no special tools or jigs. When the modification is completed, the Model 78-FM can be used either in conjunction with the Model

M-275 or for carrier frequencies between 86 Mc. to 108 Mc.

If a Model M-275 is purchased with a Model 78-FM the necessary conversion will be made at the factory.

FEATURES:

- Careful filtering minimizes spurious frequencies.
- Amplitude modulation exclusive of, or combined with FM.
- Built-in power supply.
- Easily connected to 78-FM and adjusted for required output.

USES:

The Model M-275 enhances the usefulness of the Model 78-FM by providing carrier output at 4.5 Mc., 10.7 Mc., and 21.7 Mc. for the adjustment of intermediate frequency stages.

INTERMEDIATE FREQUENCY CONVERTER—Model M-275

SPECIFICATIONS:

Frequencies: 4.5 megacycles, 10.7 megacycles, 21.7 megacycles. Provision for one extra frequency.

Frequency Accuracy: Equivalent to accuracy of Model 78-FM. $\pm 0.5\%$.

Output Voltage: When used with the Model 78-FM Signal Generator the output voltage is variable from 10 microvolts to 1 volt.

Output System: 35 ohm coaxial cable terminated in its surge impedance.

Amplifier Bandwidth: ± 250 kilocycles from center frequency.

Amplitude Modulation: Up to approximately 80% AM, combined with, or exclusive of FM. There is negligible spurious FM due to AM. Envelope distortion is less than

10% at 80% modulation. 2.25 volts r.m.s. input across 100K ohms will produce approximately 70% AM. Frequency response is flat from d.c. to 5 kilocycles.

Leakage: 82 Mc., leakage less than 50 microvolts at the output terminals. 82 Mc. leakage field around instrument less than 2 microvolts with full output.

Power Supply: 117 volts, 50-60 cycles, 45 watts.

Step-down transformer available for 220 volts, 50 cycle operation.

Dimensions: 10" high x 13" wide x 7" deep, overall.

Weight: Approximately 15 pounds.

Tubes: 1—6C4
3—6AK5
1—5Y3GT
1—OD3/VR-150

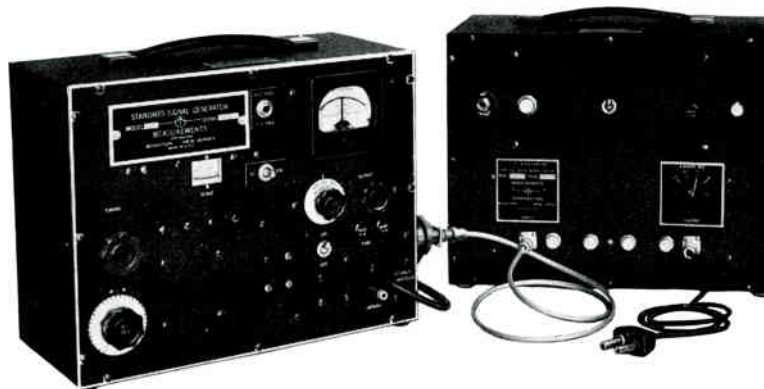

STANDARD SIGNAL GENERATOR—Model 80

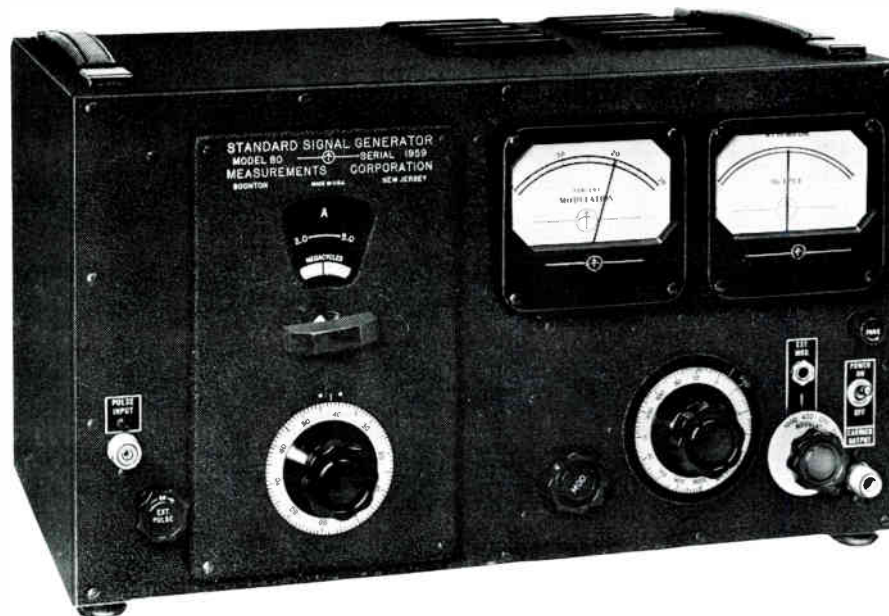

THE Model 80 is a completely self-contained instrument with built-in power supply and modulator.

This Signal Generator covers a wide frequency range of 2 to 400 megacycles and provides an output voltage, continuously variable from 0.1 microvolt to 0.1 volt, with a mutual inductance type attenuator. Very accurate indication of output voltages at all carrier levels is obtained with a precision barretter bridge. The output meter serves as a balance indicator for this bridge circuit. All values of carrier output are obtained with reference to an absolute level of 0.1 volt.

The Colpitts type split-stator, plate-modulated oscillator circuit is very stable as all critical parts are rigidly mounted. No moving contacts are used in the tuning condenser and all gears are spring-loaded to keep backlash at a minimum.

An internal modulator provides 400 or 1000 cycles. Amplitude modulation from an external source may also be used. Pulse modulation can be applied, through a special connector, directly to the oscillator.

Expertly designed, manufactured and tested under most rigid specifications, the Model 80 is an extremely stable and accurate instrument. It is very adaptable for laboratory work or production testing.

FEATURES:

- Direct reading scales and dials; individually calibrated.
- Carrier frequency, modulation frequency, modulation depth and output voltage amplitude controls designed for ease of operation.
- Accurate indication of output voltages at all levels.
- Built-in power supply and modulator.
- Provision for external pulse modulation.

USES:

The Model 80 covers the wide frequency range of 2 megacycles to 400 megacycles providing accurate test signals for testing the varied radio and television equipment operating within these frequencies.



STANDARD SIGNAL GENERATOR—Model 80

SPECIFICATIONS:

Carrier Frequency Range: 2 to 400 Megacycles in 6 bands.

Frequency Accuracy: Individually calibrated dial direct reading to an accuracy of $\pm 0.5\%$. Backlash less than 1.5 parts in 1850.

Frequency Drift: Less than .1% after warm-up.

Output Voltage: Continuously variable from 0.1 to 100,000 microvolts.

Output Accuracy: At 0.1 volt, the output voltage accuracy is $\pm 10\%$ from 2 megacycles to 200 megacycles. From 200 megacycles to 400 megacycles, at 0.1 volt, the output voltage accuracy is $\pm 15\%$.

Output System: An internal 50 ohm cable connects to a 50 ohm panel jack.

A 50 ohm matching pad (Part No. 80-ZH3) and a 50 ohm cable (Part No. 80-ZH4) are recommended for use with the Model 80 to isolate the attenuator system from any standing wave effects which may be present in loads of uncertain impedance. Other matching pads and cables are available as shown on page 38.

Leakage and Stray Fields: Attenuator leakage less than 0.1 microvolt. Power line leakage less than 0.5 microvolt. Stray fields less than 2 microvolts one inch or more from panel.

Modulation: Amplitude modulation is continuously variable from 0 to 30% and is indicated by a meter on the panel. Internal modulation of 400 cycles or 1000 cycles is available; modulation may also be applied from an external source. Pulse modulation may be applied to the oscillator from an external source through a special connector.

Power Supply: 117 volts, 50 to 60 cycles, 70 watts. Step-down transformer available for 220 volts, 50 cycle operation.

Dimensions: $10\frac{3}{4}$ " high x 19" wide x $9\frac{1}{2}$ " deep, overall.

Weight: Approximately 45 pounds.

Tubes: 1—955
1—5Y3GT
2—6V6 or 6V6GT
1—6SJ7 or 6SJ7GT
1—VR105/30
2—6SN7GT
1—6SL7GT
1—OA3/VR75

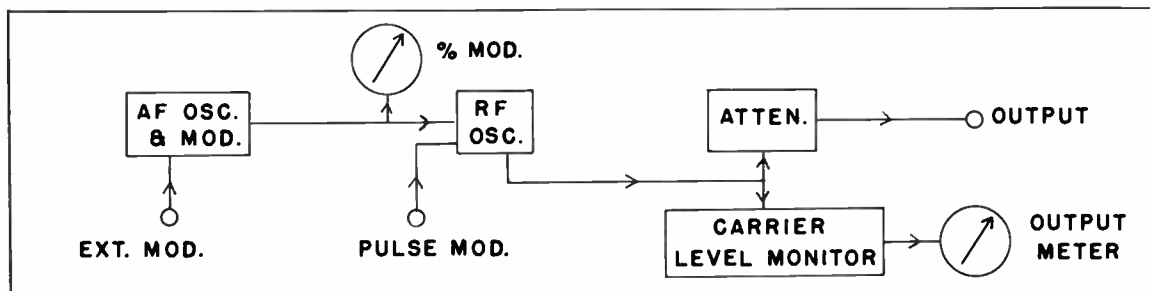

MODEL 80 BLOCK DIAGRAM



TELEVISION
STANDARD

SIGNAL GENERATOR - Model 90

THIS instrument is the first commercial wide-band, wide-range, standard signal generator ever to be developed. It is of the master oscillator, buffer-amplifier, modulated power amplifier type, and the output circuits are of the double-tuned, over-coupled, band-pass type, permitting modulation frequencies up to 5 megacycles. Excellent isolation is obtained between the final amplifier and oscillator, thus eliminating incidental frequency modulation.

The equipment is mounted in rack and panel style with a dust cover over the rear. Forced ventilation with dust filters is provided. A removable panel permits the installation of some accessory equipment such as: a sine-wave oscillator, square wave generator, pattern generator, a synchronizing signal generator, mixing amplifier, etc.

The carrier range of 20 to 250 megacycles is covered in eight coil ranges. A self-contained crystal calibrator permits the setting of even megacycle carrier frequencies to 0.01% or better. Setting accuracy of the direct reading frequency dial is 0.1%.

Video modulation is obtained from a built-in video modulator having a band width of 5 megacycles and designed to operate from a standard RMA composite signal. Continuous monitoring is provided by a built-in oscilloscope which displays the output of a keyed d.c. potentiometer superimposed on the video for accurate determination of modulation levels. Accurate measurements can be made for use in the study of transfer characteristics, etc. External sweep can also be used on the monitor oscilloscope for detailed studies of interlacing, etc. Optional d.c. insertion is provided in the modulator. Manual insertion and composite signal level controls are also provided.

The balanced attenuator of the mutual inductance type operates on the transverse magnetic field as a wave-guide below cut-off. Balanced output is secured by operating two co-axial outputs out of phase. This attenuator can be used unbalanced to ground, if desired. A self-calibrating, crystal rectifier is used for standardizing the unmodulated carrier level corresponding to the synchronizing tips.



A specially designed voltage regulator, mounted on casters for easy movement, is furnished as standard equipment with the Model 90.

SPECIFICATIONS:

CARRIER FREQUENCY

Range: 20 to 250 megacycles in eight ranges. Individually calibrated scales.

Accuracy: Built-in Crystal Frequency Standard permits setting to .01%. Dial scale may be set to 0.1%.

Stability: Warm-up drift less than .05%; less than .01% after warm-up.

Leakage: Less than 10 microvolts.

MODULATION

Continuously variable from zero to 100%.

Envelope: Sinusoidal, or composite television. Bandwidth to 3 db is 4 Mc. Rise time from 10% to 90% modulation 0.15 microsecond. Overshoot less than 5%. Slope less than 5% on 60 cycle square wave.

Input Impedance: 75 ohms \pm 10% (RMA Standard).

Input Level: 1.5 volts peak to peak minimum level for 100% modulation. Black negative polarity.

Modulation Percentage: 15% to 110% within \pm 2%.

OUTPUT

Level: Continuously variable from 0.3 microvolt to 0.1 volt balanced to ground (measured at 100% modulation level).

- Impedance:**
- (a) 107 ohms line to line (balanced).
 - (b) 53.5 ohms line to ground (unbalanced).
 - (c) Suitable pads may be employed to alter these impedances.

GENERAL

Dimensions: Height—58 $\frac{3}{4}$ "; Width—28 $\frac{1}{4}$ "; Depth—25 $\frac{1}{2}$ ".

Weight: Model 90—302 pounds. External Voltage Regulator 92 pounds.

Power Supply: With regulator, 117 volts, 60 cycles—825 V.A. Without regulator, 117 volts, 60 cycles—600 V.A.

TUBE COMPLEMENT

R.F. UNIT

2—6C4 2—832A
2—6SJ7

CARRIER FREQUENCY STANDARD

2—6AK5 2—9002

MONITOR OSCILLOSCOPE

1—3CP1 3—6J6
2—0B2 1—6AL5
1—B3GT/8016

MODULATOR

2—6AG7 1—0A2
1—6AL5 1—807
1—829B

POWER SUPPLY

2—5R4GY 1—5V4G
3—6AS7G 2—6L6
1—6Y6G 5—6SJ7
4—0B2

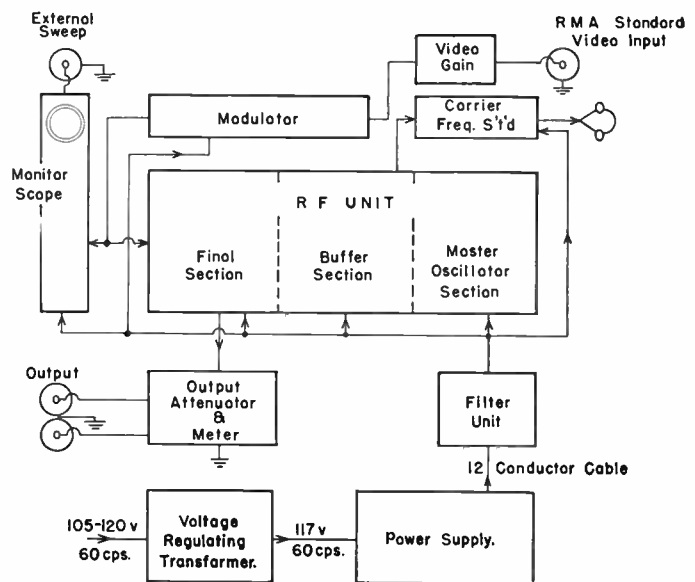

MODEL 90 BLOCK DIAGRAM



STANDARD SIGNAL GENERATOR—Model 84



THE Model 84 will meet the requirements of laboratories employed in ultra-high frequency engineering in the range of 300 to 1000 megacycles.

This instrument provides a choice of four types of test signal voltage: Continuous wave of UHF carrier, with metered output and a wide range of attenuation; Sine-wave modulated carrier, using either internal or external source of modulation with direct metering of per-cent modulation; Pulse modulated carrier using built-in pulse generator of variable repetition rate and pulse width; Synchronizing pulse output for triggering an external time axis in synchronism with the pulsed carrier.

The oscillator components are sturdily constructed and designed with only one moving part for maximum stability. The frequency band of the instrument is covered in one range.

Complete filtering of all power leads and triple shielding of the signal generator reduces radio frequency leakage to a negligible value.

For extremely accurate measurements the Model 84 can be furnished with external binding posts in order that DC may be used on the heater of the oscillator tube.

The Model 84 is manufactured and calibrated with expert care assuring the purchaser of a precision instrument that will require a minimum of adjustments and repairs throughout years of service.

FEATURES:

- Carrier oscillator range from 300 to 1000 megacycles with metered output and wide range of attenuation.
- Individually calibrated dials.
- Self-contained power supply.
- Internal modulating source of 400, 1000 and 2500 cycles per second.
- Built-in pulse modulator.
- Stray field not measurable with most sensitive receiver.

USES:

The Model 84 is recommended for the many applications in ultra-high frequency engineering that require a high degree of frequency accuracy and an output of known amplitude with residual voltage and stray fields held to an absolute minimum.



STANDARD SIGNAL GENERATOR—Model 84

SPECIFICATIONS:

Frequency Range: 300 to 1000 megacycles in one band.

Frequency Accuracy: Individually calibrated dial direct reading to an accuracy of $\pm 0.5\%$. Backlash of frequency dial is not more than 3 divisions.

Frequency Drift: Less than .05% after warm-up.

Output Voltage: Continuously variable from 0.1 microvolt to 100,000 microvolts.

Output System: The impedance at the output panel jack is 50 ohms. Two 84-Z2-1, one 84-Z2-2 and one 84-Z2-3 cables are supplied with the instrument. See page 33 for description of cables.

Modulation: 0 to 30% within $\pm 20\%$ as determined by dc meter.

Internal sine-wave oscillator provides choice of 400, 1000 or 2500 cycle modulation.

Can be externally modulated up to 30 kilocycles; approximately 5 r.m.s. volts required for 30% modulation depth.

Leakage: Line and attenuator leakage—none as measured on test receiver. No stray field, measured 2" from the panel.

Pulse Frequency: 60 cycles to 100 kilocycles in three ranges, 60-1000; 600-10,000 and 6000-100,000 pulses per second. Provision made for synchronizing pulse circuits to external source.

Pulse Width: Continuously variable 1-50 microseconds.

Pulse Delay: Continuously variable 0-50 microseconds with respect to synchronizing output pulse.

Synchronizing Output: Up to 50 volts, either polarity.

Power Supply: 117 volts, 60 cycles. External voltage regulator supplied. Regulators also available for 117 volts, 50 cycles; 220 volts, 60 cycles or 220 volts, 50 cycles. Power consumption of Model 84, 180 watts; with regulator 230 watts.

Dimensions: 12" high x 26" wide x 10" deep, overall.

Weight: Approximately 135 pounds, including external line voltage regulator.

Tubes: 2—6V6GT

1—6H6

1—OC3/VR105

1—6SJ7

1—OD3/VR150

4—6SN7-GT

2—6J5

2—6AG7

1—6L6

2—5Y3G or 5Y3GT

1—368AS or 703A

1—5R4GY

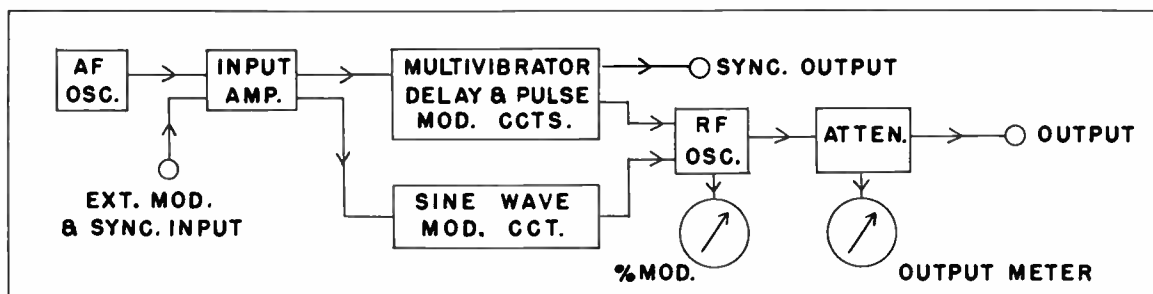

MODEL 84 BLOCK DIAGRAM



PULSE GENERATOR – Model 79-B



FOR applications where a pulse of known repetition rate and width is required, the Model 79-B Pulse Generator is recommended. This instrument is very useful for checking the transient responses of video and r.f. amplifiers and in the investigation of peak measuring equipment. It may be used as a radio noise generator to simulate ignition and other types of interference for research on the elimination of such interference in radio equipment.

The Model 79-B has a built-in multivibrator type oscillator providing its own frequency source which can be locked with a sine-wave or other external source when frequency accuracy is of prime importance.

A pulse modulator is provided for applying "pulse modulation" to the carrier wave of a signal generator such as Measurements Model 80 Standard Signal Generator. This combination will provide pulses down to one microsecond at the higher carrier frequencies.

The many new applications of pulse circuits make the Model 79-B an important instrument for laboratories engaged in this field of research and design.

FEATURES:

- Wide frequency range.
- Continuously variable pulse width.
- Built-in multivibrator, pulse modulator and power supply.
- Provision for synchronization to external frequency standard.

USES:

The Model 79-B generates voltage pulses of variable width and frequency for use with associated equipment such as the Model 80 Standard Signal Generator.

PULSE GENERATOR - Model 79-B

SPECIFICATIONS:

Frequency Range: 60 to 100,000 pulses per second.

Pulse Width: Continuously variable from 0.5 to 40 microseconds.

Pulse Shape: Rise time: approximately 0.5 microseconds. Decay time: no more than 25% of pulse width (at 70% peak) at a repetition rate 4 times pulse width.

Output Voltage: Approximately 150 volts (peak) positive with respect to ground.

Output Impedance: 6Y6G cathode follower with 1000 ohm load.

Synchronizing Input: May be synchronized with as little as 2 volts peak from an external source.

Synchronizing Output: 75 volts positive with respect to ground. Displaced by $\frac{1}{2}$ period from pulse output.

R. F. Modulator: Useful to over 50 megacycles. Attenuator provides fixed outputs of 1/10 and 1/100 of carrier input level from separate jacks. Output impedance approximately 66 ohms at X.1 jack and 7 ohms at X.01 jack.

Power Supply: 117 volts, 50-60 cycles AC, 115 watts.

Step-down transformer available for 220 volts, 50 cycle operation.

Dimensions: 10" high x 13 $\frac{5}{8}$ " wide x 10 $\frac{1}{2}$ " deep overall.

Weight: Approximately 31 pounds.

Tubes: 2—5V4G

1—OD3/VR150

2—6AG7

1—6SA7

3—6C5 or 6C5GT

1—6Y6G

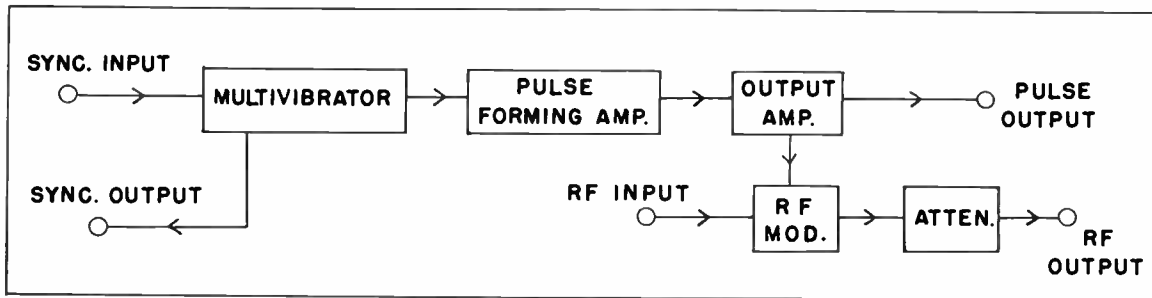

MODEL 79-B BLOCK DIAGRAM



SQUARE WAVE GENERATOR—Model 71



THE technique of square wave analysis is now standardized for testing television equipment.

With the Model 71 performance characteristics of audio, video and r.f. amplifiers may be quickly determined. Using this Square Wave Generator the engineer can observe wave shapes on a cathode-ray oscilloscope; varying the frequency of the square wave expands or compresses the time base thus permitting observation of both rise time and overshoot of the front of the wave or its top slope or decay. Rapid alignment of wideband i.f. amplifiers is made possible by the employment of this new square wave technique.

The Model 71 contains a built-in, multivibrator type oscillator providing its own frequency source, which may easily be locked with a sine-wave or other external source when frequency accuracy is important. A variable attenuator is supplied to reduce output voltage to the desired value.

An r.f. modulator is provided so that square envelopes of r.f. energy may be used to measure the characteristics of r.f. and i.f. amplifiers. The Model 71 has been widely

used to check amplitude, phase, frequency and transient response on all types of amplifiers. It is compact and self-contained and has been found an estimable timesaver wherever square wave analysis is employed.

This instrument is of proven design and performance and can readily be used in many different applications in the development of AM, FM and television equipment.

FEATURES:

- Wide frequency range.
- Built-in multivibrator, r.f. modulator and power supply.
- Frequency and output easily adjusted by individually calibrated controls.
- Compact; weighs only 15 pounds.

USES:

Performance characteristics of audio, video and r.f. amplifiers may quickly be determined by coupling a Model 71 to the equipment under test and observing the resultant wave shapes on a cathode-ray oscilloscope.



SQUARE WAVE GENERATOR—Model 71

SPECIFICATIONS:

Frequency Range: Continuously variable from 6 to 100,000 cycles per second.

Wave Shape: Rise time less than 0.2 micro-seconds with negligible overshoot at 75 peak volts output. At 5 volts or less, rise time is less than 0.1 microsecond.

Output Voltage: Step attenuator giving 75, 50, 25, 15, 10, 5 peak volts fixed and 0 to 2.5 volts continuously variable.

Output Impedance: 20 ohms per volt.

Synchronizing Output Voltage: 25 volts peak.

Synchronizing Output Impedance: 1500 ohms.

Synchronizing Input Impedance: Over 20,000 ohms.

R. F. Modulator: 5 volts maximum carrier input. Transla-

tion gain is approximately unity. Output impedance is 600 ohms.

Power Supply: 117 volts, 50-60 cycles. Self-contained, no batteries. 100 watts. Step-down transformer available for 220 volts, 50 cycle operation.

Dimensions: 7" high, 15" wide, 7½" deep.

Net Weight: Approximately 20 lbs.

Tubes: 2—6AG7

3—6J5

1—6SA7

1—OD3/VR150

1—5Y3G

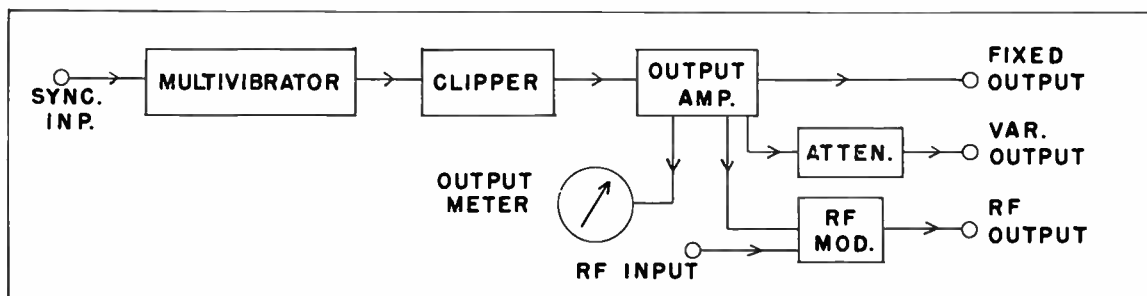

MODEL 71 BLOCK DIAGRAM



UHF RADIO NOISE & FIELD STRENGTH METER—Model 58



THE Model 58 has met the ever-increasing demand for a portable instrument useful in the investigation of ignition and other types of radio noise, in measuring signal-to-noise ratios, noise levels and for field strength surveys on television and FM transmitters.

The instrument may be operated on an ac source for laboratory use or from a 6 volt dc source when used in the field.

The Model 58's pass band is sufficiently wide to permit accurate field-strength measurements of frequency modulated signals down to the levels of a few microvolts per meter. In the width of its pass-band and the time constants of its weighting circuits, the Model 58 represents a worthwhile improvement over earlier instruments. Measurements closely approaching peak values and hence the true nuisance values of ignition and various other pulse type noises can be made.

Standard equipment furnished with the Model 58 consists of one 9" loop antenna; 15 feet of antenna cable; one power cable for ac operation; one power cable for

battery operation; adjustable carrying strap and instruction book.

A complete accessory kit, as described on page 39, is available. The type 58-Z12 (B-265) High-Impedance Probe is recommended for coupling the Model 58 to an external circuit for measuring r.f. voltages without disturbing the external circuit conditions.

FEATURES:

- Light weight, compact for portable use.
- Built-in ac and dc power supply.
- Self-contained calibration circuit.
- Large hand-calibrated frequency and microvolt scales.
- Push button switching.

USES:

The Model 58 is suitable for the measurement of steady carrier voltages or fields; as a sensitive voltmeter for measuring line loss; front-to-back ratios of directional antennas; signal-to-noise ratios of antennas; effectiveness of noise filters, etc.

UHF RADIO NOISE & FIELD STRENGTH METER—Model 58

SPECIFICATIONS:

Frequency Range: 15 to 150 megacycles in five bands.

Frequency Accuracy: Dials directly calibrated in megacycles to an accuracy of $\pm 2\%$.

Input Voltage Range: 1 to 100,000 microvolts induced in the antenna. 1 to 100 microvolts on semi-logarithmic output meter, balanced resistance attenuator with ratios of 10, 100 and 1000 ahead of all tubes.

Gain Standardization: Internal "shot noise" diode provides calibration standard. Special dial eliminates need for charts.

Circuit: Superheterodyne circuit with tuned R.F. amplifier eliminates image response.

Band Width: 150 kilocycles @ 2 x down.

Power Supply: Built-in regulated dual power supply for operation from either 117 volts AC (70 watts) or 6 volts

DC. Step-down transformer available for 220 volts, 50 cycle operation.

Standard Equipment: Power cables, 15 foot antenna cable, 9 inch loop antenna, carrying strap and instruction book.

Dimensions: 9" high x 16" wide x 11" deep overall.

Weight: Approximately 35 pounds.

Tubes: 3—7W7
1—6X5GT
1—6J5GT
1—6Y6G
1—6H6
1—6SJ7
1—955
2—6AK5
1—M74

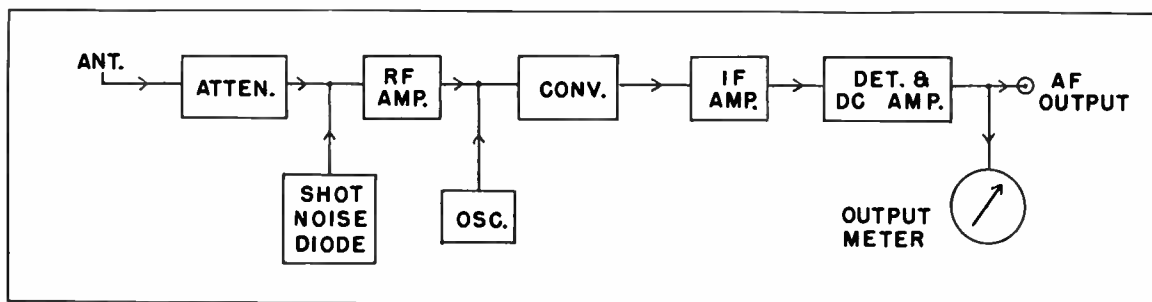

MODEL 58 BLOCK DIAGRAM



VACUUM TUBE VOLTMETER—Model 62

THE many outstanding features of the Model 62 Vacuum Tube Voltmeter has made it one of the most popular instruments in the Measurements line.

This zero current voltmeter with range selection push-buttons and easily-read meter provides a rapid and accurate means of measuring AC or DC voltage with a minimum frequency error from 30 cycles to over 150 megacycles.

The Model 62 was designed with stabilized, balanced, degenerative amplifiers to make possible the changing of DC voltage ranges without the readjustment of zero for each range. The balanced diode circuit minimizes zero drift on AC voltage measurements.

A detachable probe is provided for measurements at high frequencies without error due to lead length. For measurements at low or medium frequencies where lead length is not a consideration, the probe may be mounted on convenient carrying jacks on the rear of the instrument. When used as a DC meter the input resistance is practically infinite providing an accurate means of making measurements that are impossible with other types of direct-reading meters.

The Model 62 may be used as a high-range ohm meter for measuring resistance from 0.1 to beyond 100,000 megohms. The addition of a battery or other external source of potential is required.

The Model 62 U.H.F., with Special Probe for measurements from 100 KC to 500 Mc., is also available.

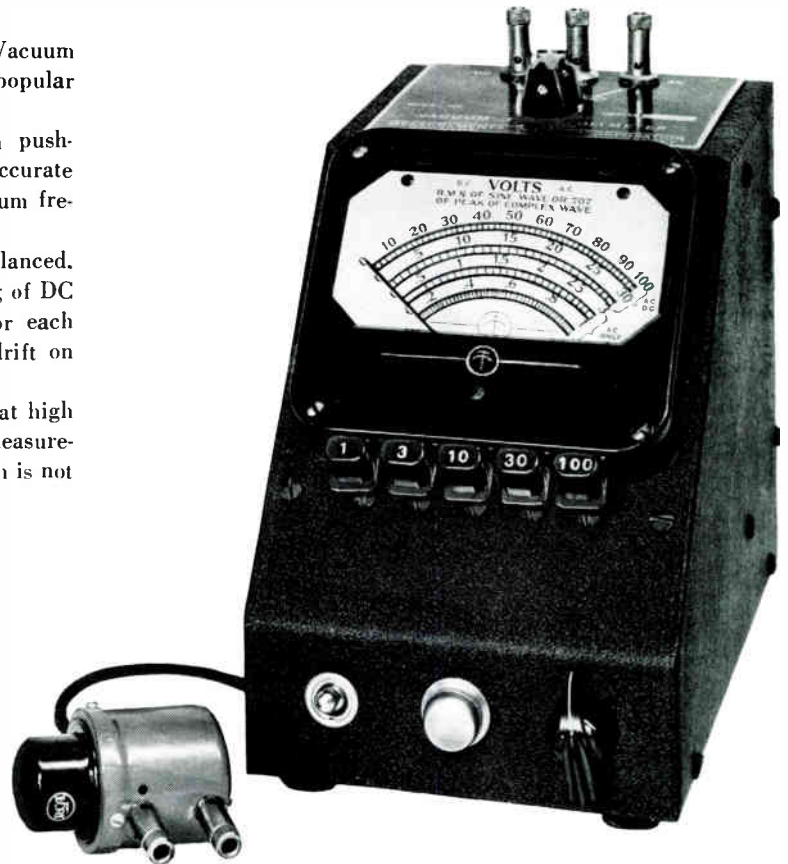

FEATURES:

- Stabilized, balanced degenerative amplifiers eliminate "zero-shift"; no change of zero with range selection.
- High input resistance on d.c. voltage measurements.
- Balanced diode minimizes zero drift on a.c.
- Large easily-read, hand calibrated scale.

USES:

Calibrated to indicate r.m.s. values of a sine-wave or 71% of the peak value of a complex wave on a.c. With proper associated equipment the Model 62 can be used as a light intensity and quantity instrument, as a Ph meter and for many other special applications.

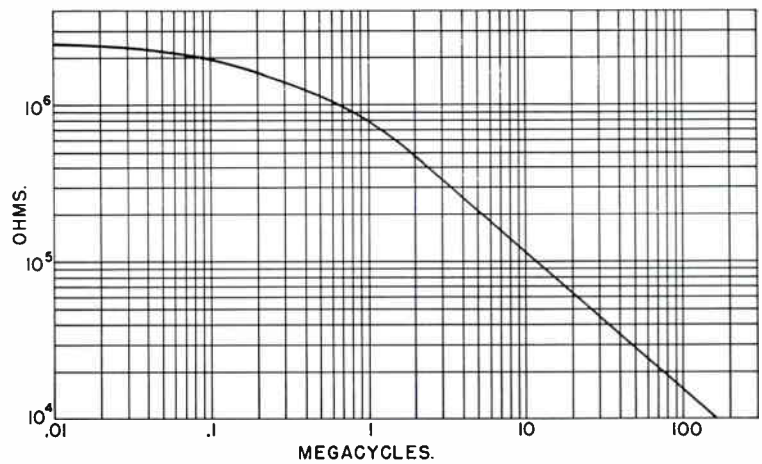

PROBE INPUT RESISTANCE

VACUUM TUBE VOLTMETER—Model 62

SPECIFICATIONS:

Voltage Range: 1, 3, 10, 30 and 100 volts full scale AC or DC. Push button range selector.

Accuracy: $\pm 2\%$ of full scale on each range, both DC and sine-wave AC, at line voltage of 117v.

Indication: Linear for DC and calibrated to indicate r.m.s values of a sine-wave or 71% of the peak value of a complex wave on AC.

Frequency Error: Less than 10% from 30 cycles to over 150 megacycles. Resonant frequency of the probe with input terminals shorted is 350 megacycles.

Input Impedance: The input capacitance is approxi-

mately 7 mmf. The input resistance is a function of frequency and is plotted in chart shown on page 29.

Power Supply: 117 volts, 50 to 60 cycles. 24 watts.

Step-down transformer available for 220 volts, 50 cycle operation.

Dimensions: 6" high x 4 $\frac{3}{4}$ " wide x 8 $\frac{1}{2}$ " deep, overall.

Weight: Approximately 8 pounds.

Tubes: 1—6H6
1—5W4
2—6C5

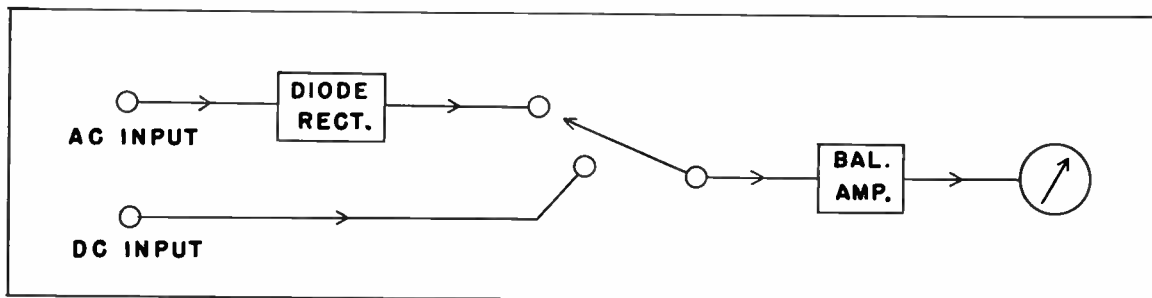

MODEL 62 BLOCK DIAGRAM



PEAK VOLTMETER – Model 67

THE Model 67 was designed to meet the need for a sensitive voltmeter capable of indicating the true peak value of complex waves encountered in radio and allied electronic work.

This instrument makes possible many new types of measurements which can not satisfactorily be made with copper oxide meters and electronic voltmeters of the r.m.s. type.

The Model 67 indicates the true peak-to-peak value of symmetrical and asymmetrical waveforms varying from low frequency square waves to pulses of less than five microvolts duration. It will prove of value in the measurement of complex waves in impulse and ignition radio noise, speech, music and video work. For mechanical vibration measurements and stress analysis, the Model 67's peak characteristics, low frequency response extending down to 5 c.p.s. and high sensitivity makes it possible to operate the instrument directly from strain gauge bridges without intervening amplifiers or carrier system.

FEATURES:

- Measures true peak voltages in the range from .0005 to 300 volts.
- Semi-logarithmic, hand calibrated, easily read scales.
- Provision for connection to external graphic recorder.



USES:

Designed for audio and video level measurements and the measurement of audio electrical interference and radio interference. The Model 67 is ideally suited for uses where the indication of true peak values is required.

PEAK VOLTMETER – Model 67

SPECIFICATIONS:

Voltage Range: 5 ranges permitting measurements from .0005 to 300 volts peak-to-peak. (Approximately .0002 r.m.s. volts to 100 r.m.s. volts.)

Semi-Logarithmic Scales: Hand calibrated; 0 to 30 peak-to-peak and 0 to 10 r.m.s. equivalent.

Frequency Range: 5 to 100,000 sine-wave cycles per second.

Input Impedance: 1 megohm shunted by 30 mmfd.

Stability: Less than 2% error with line variations from 110 volts to 120 volts.

Tube aging or replacement affects accuracy by less than 2%.

Recorder Terminals: Self-shorting type for external one milliamper graphic recorder or milliammeter.

Power Source: 117 volts, 50 to 60 cycles, 35 watts.
Step-down transformer available for 220 volts. 50 cycle operation.

Dimensions: Height 7½", Width 7", Depth 8½".

Weight: Approximately 10 lbs.

Tubes: 2—6SH7
1—6H6
1—6SN7GT
1—OD3/VR150
1—6X5GT

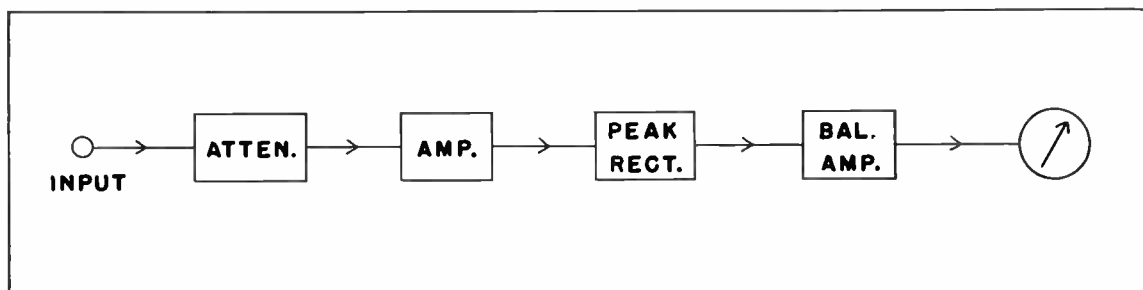

MODEL 67 BLOCK DIAGRAM



MEGACYCLE METER – Model 59

THE Model 59 Megacycle Meter is essentially the familiar “grid-dip” oscillator, however, it is the first commercial instrument of this type to cover such a wide frequency range and to incorporate important features that make it useful for so many different applications.

This versatile instrument consists of a compact oscillator unit, calibrated for direct reading from 2.2 Mc. to 400 Mc., connected by a small flexible cord to the power supply.

As a “grid-dip” meter the Model 59 has many uses such as for resonating all the tuned circuits of a transmitter or receiver, including oscillator and antenna, with the power off.

The instrument may be used for measuring capacitance, inductance, mutual inductance, “Q”; as an auxiliary signal generator; as a low sensitivity receiver for signal tracing; as an oscillating or absorption marker; for locating parasitic circuits; for checking amplitude modulation and keying of transmitters. In fact, the applications of the Model 59 are so varied it is possible to suggest only a few of its principal uses.

The Megacycle Meter will prove an indispensable instrument for anyone engaged in electronic work—engineer, serviceman, amateur or experimenter.

FEATURES:

- A frequency coverage never before incorporated in “grid-dip” meters.
- Internal modulation as well as provision for external modulation.
- Oscillator unit designed for coupling to circuits in small spaces.
- Large easily-read meters.
- Individually calibrated frequency dial.

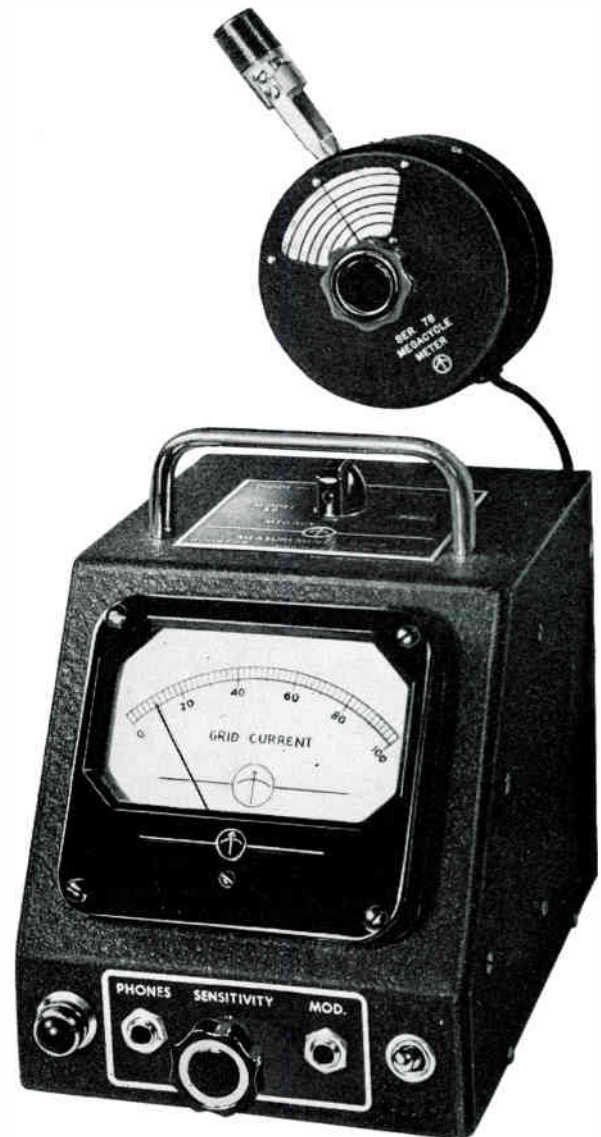

MEGACYCLE METER – Model 59

USES:

For determining the resonant frequency of tuned circuits, antennas, resonant transmission lines or any resonant circuit.

For measuring capacitance.

For measuring inductance.

For measuring Q.

For measuring the resonant frequency of video peaking coils.

For measuring mutual inductance.

For preliminary aligning and tracking of receiver and transmitter circuits with power off.

As an auxiliary signal generator for final alignment of receivers. Modulated or unmodulated.

As a low sensitivity receiver for tracing the source of unwanted oscillations in receivers or transmitters.

As a beat-frequency oscillator in conjunction with a fixed frequency oscillator for measuring video or wideband amplifier bandwidths.

As an oscillating or absorption marker for use with a sweep-frequency oscillator.

Checking antenna tuning, tuned circuit frequency and neutralizing with transmitter power off.

Locating parasitic circuits and spurious resonances in transmitters and receivers.

Transmitter or oscillator frequency checking by beat note method and absorption wavemeter method.

Checking of amplitude modulation and keying of transmitters.

The use of the Megacycle Meter as a “grid dip meter” is most important since it searches out troublesome parasitic resonant circuits in the most unex-



pected places. By its use as a “grid dip meter” the Model 59 may be used to resonate all the tuned circuits of a transmitter or receiver, including oscillator and antenna, before the power is turned on.

The selectivity of a receiver or transmitter may be determined (when the bandwidth is sufficiently wide for measurement with the Megacycle Meter) by using it in conjunction with another oscillator, either fixed frequency or frequency modulated, as a beat-frequency oscillator.

As an oscillator the Megacycle Meter may be used as a marker in conjunction with a sweep (or frequency modulated) oscillator to indicate the frequency at any point. This method is more accurate than an absorption type marker because of the type of indication seen on the oscilloscope screen.

Various methods of modulation may be used with the instrument such as plate modulation, absorption loop modulation or sweep modulation.

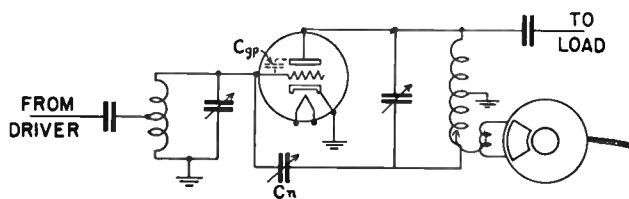

MEGACYCLE METER – Model 59

AN approximate determination of the Q of a resonant circuit may be obtained by tuning the Megacycle Meter through the frequency of the circuit and noting the sharpness of the “dip” in the meter indication. The method of measuring the Q of a tuned circuit is described fully in the instruction book.

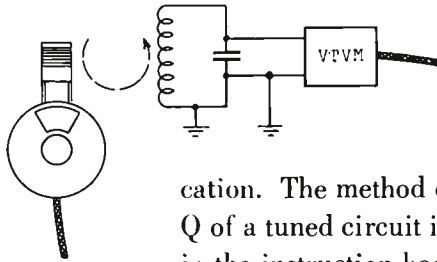

As a source of energy the Model 59 may be used with the latter stages of a transmitter to obtain the proper coupling of the antenna to the output stage without energizing the rest of the transmitter.

Transmitter or oscillator signals may be checked in frequency or for character of signal, such as

hum, motorboating, etc., by inserting headphones in series with the grid resistor and listening to the beat note between the oscillator and Megacycle Meter.

With the plate voltage off, the oscillator tube of the Model 59 acts as a rectifying diode. The coil is coupled to the transmitter or oscillator to be measured and tuned for a maximum reading of the grid current meter thus providing an effective absorption wave meter.

As a tuned circuit absorption detector, the plate voltage may be switched off and a set of headphones plugged in the telephone jack so that the rectified current in the grid circuit passes through the headphones. The energy picked up by the tuned circuit coil of the Megacycle Meter produces a voltage across the coil; this voltage is rectified and the modulation heard in the headphones.

SPECIFICATIONS:

Frequency Range: 2.2 megacycles to 400 megacycles with seven plug-in coils.

Frequency Accuracy: Individually calibrated dial. direct reading to an accuracy of $\pm 2\%$.

Output: CW or MCW. Modulation fixed at approximately 30%, 120 cycles.

Tubes: 1—Type 955
1—Type OD3/VR150
1—Type 5Y3GT

Dimensions: Power unit: 5 $\frac{1}{8}$ " wide, 6 $\frac{1}{8}$ " high, 7 $\frac{1}{2}$ " deep.
Weight: approximately 6 $\frac{1}{2}$ lbs.

Oscillator unit: 3 $\frac{3}{4}$ " diameter, 2" deep.
Weight: approximately 1 lb.

Power Supply: 117 volts, 50-60 cycles, 20 watts.

Step-down transformer available for 220 volts, 50 cycle operation.

USES:

For the measurement of capacitance inductance, relative “Q”, mutual inductance; resonant frequency of tuned circuits, antennas, transmission lines; as an auxiliary signal generator; for signal tracing; as a marker for use with a sweep-frequency generator, etc.



R. F. ATTENUATOR—Model M-234

THE M-234 is a co-axial attenuator of the mutual inductance type operating on the transverse magnetic field as a wave guide below cut-off. A rack and split gear drive assure long life and smooth operation. This attenuator is well suited to many specialized applications such as: AM, FM, and Television receiver production test equipment, stage gain test sets, filter test sets, etc.

SPECIFICATIONS:

Output Range: 0.3 to 100,000 microvolts.

Output Calibration: Calibrated at 100,000 microvolts across terminated output by 1N21 crystal.

Output Impedance: Matched 50 ohm line from type N connector. 25 ohm when used with 4' terminated binding post cable, Part 80-ZH4 (upper frequency limit approximately 200 megacycles).

Frequency Range: 2 to 1000 megacycles.

Dimensions: Width 10 $\frac{1}{8}$ "", height 9 $\frac{5}{8}$ "", depth 5 $\frac{1}{2}$ " incl. knobs.

Weight: Approximately 3 $\frac{1}{2}$ pounds.

R. F. ATTENUATOR—Model M-235

THE M-235 is a balanced attenuator of the mutual inductance type operating on the transverse magnetic field as a wave-guide below cut-off. Balanced output is secured by operating two co-axial outputs back to back out of phase. A rack and split gear drive assure long life and smooth operation. Designed for use in many specialized applications such as: FM and television receiver production test equipment, transmission line test sets, antenna test sets, etc.

SPECIFICATIONS:

Output Range: 0.3 to 100,000 microvolts.

Output Calibration: Calibrated at 100,000 microvolts (line to line) across terminated output by 1N21 crystals.

Output Impedance: Matched 100 ohms line to line or 50 ohms to ground from two type N connectors. One-half the above values when used with two 4' terminated binding post cables, Part 80-ZH4 (upper frequency limit approximately 200 megacycles).

Frequency Range: Approximately 2 to 300 megacycles.

Dimensions: 10 $\frac{1}{8}$ " wide, 9 $\frac{5}{8}$ " high, 5 $\frac{1}{2}$ " deep incl. knob.

Weight: Approximately 3 $\frac{3}{4}$ pounds.

MEGOHM METER MODEL 183-B

THE Megohm Meter was designed to accurately measure unknown resistances of values from 300 to 100,000 megohms, in two overlapping ranges. The scale has the conventional ohmmeter characteristics figured from 300 to 100,000 megohms and the measurements in this range are accurate within $\pm 5\%$ when the upper or expanded portion of the scale is used. Beyond 10,000 megohms the error increases because of the compressed scale.

In operation, the voltage on the unknown resistor being measured varies between 425 to 450 volts for indications between 300 to 100,000 megohms.

This instrument is suitable for the testing of power cords as measurements are made at voltages exceeding those used in normal operation. Megohm Meters can be supplied with resistance ranges to meet the individual requirements of the customer.

The instrument is supplied in a metal case having a black, wrinkle finish. The case is 4 $\frac{3}{4}$ " wide, 6" high and 10 $\frac{1}{2}$ " deep, weighing 8 pounds.

As a safety measure, the outside case is well insulated from the chassis making it impossible for an operator to make contact across the d.c. power supply.



L-C-R BRIDGE-Model 102

THIS compact instrument will prove most useful in the laboratory or shop, as inductance, capacitance and resistance measurements can all be made with this one unit, thus eliminating the need for several different instruments.

The main dial is calibrated for L, C and R on an easily-read semi-logarithmic scale. The Model 102 is AC operated, with a built-in power supply, 1000 cycle oscillator, tuned amplifier and null indicator. No external equipment is required; however, provision has been made for connections to external standards to extend the range of the instrument.

TENTATIVE SPECIFICATIONS:

Inductance (L) 0.5 microhenry to 110 henries. R_L dial reads directly in resistance equivalent to a Q of approximately 0.1 to infinity.

Capacitance (C) 1 mmf. to 110 mfd. P_F dial reads directly in % power factor from 0-30%.

AC Resistance (R) 1 ohm to 11 megohms.

Accuracy: Better than $\pm 2\%$ on practically all ranges.

SPECIAL TEST EQUIPMENT

SHOWN at the right is Measurements' Model M-310 Standard Signal Generator designed and manufactured to customer specifications.

This special instrument covers the frequency range of 50 megacycles to 90 megacycles. The maximum output is 1 milliwatt across 75 ohms, with an attenuator calibrated in 1 db steps from 0 to 120 db.

Consult us regarding your requirements for special electronic measuring equipment. While our standard instruments are suitable for most applications, minor modifications can often be made to adapt them to your particular needs.

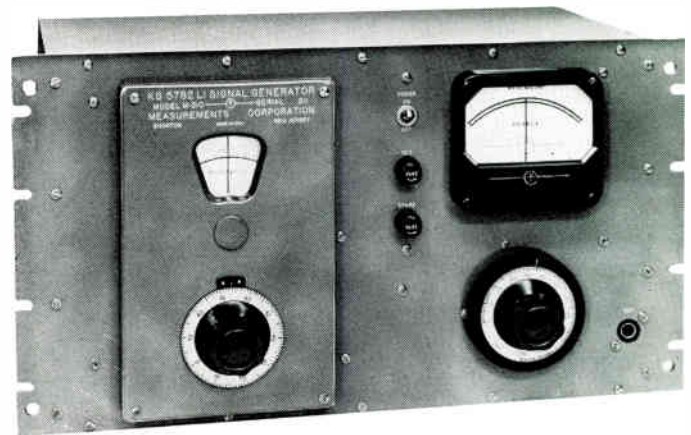

STANDARD SIGNAL GENERATOR—MODEL M-310



CAPACITANCE BRIDGE—MODEL 101

We will gladly estimate the cost of such modifications or of designing and producing a special unit for you.

Measurements Corporation engineers have designed several special bridges including an inductance bridge and the Model 101 Capacitance Bridge shown at the left.

The Model 101 will measure capacitance from 0.1 mmf. to 1 mfd. in five ranges with power factors from 0.1% to 10%.

The instrument is completely self-contained, with a built-in oscillator, audio amplifier and meter-type null indicator.

MODEL 80 CABLES, PADS, MATCHING TRANSFORMER

These Accessories are available on order but are not furnished as standard equipment with the purchase of a Model 80 Standard Signal Generator.

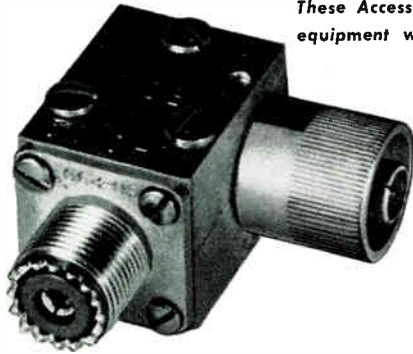

Part No. 80-ZH1
With Navy Type 49194 Output Jack

The two Matching Pads, Numbers 80-ZH1 and 80-ZH3 for use with the Model 80 are electrically the same but differ as to their types of output jacks. The purpose of both pads is to isolate the attenuator system of the Model 80 from any standing wave effects which may be present in loads of uncertain impedance. They present a constant 50 ohm load to the generator, accompanied by a constant insertion loss of 6 db; a voltage drop of 50%.

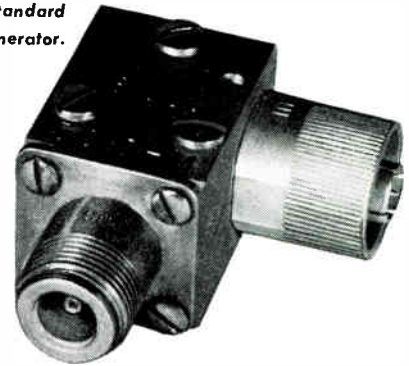

Part No. 80-ZH3
With Navy Type 49470 Output Jack

CABLES



Part No. 80-ZH4

A 4 ft. coaxial cable (RG-55/U) that may be used with the 80-ZH3 Pad at frequencies as high as 200 Mc. One end of the cable is terminated in an AN Type UG-21/U (Navy Type 49268) connector, while the other end has a binding post termination. (With 50 ohm resistor.)

Part No. 84-Z2-2

4 ft. 50 ohm coaxial cable (RG-8/U) for use with pad, 80-ZH1 or 80-ZH3, as one end of the cable is terminated in a Navy Type 49195 connector plug and the other end has an AN Type UG-21/U (Navy Type 49268) connector plug.



Part No. 84-Z2-3

4 ft. coaxial cable (RG-8/U) with both ends terminated in AN Type UG-21/U (Navy Type 49268) connector plugs. This cable may be used with 80-ZH3 pad and is preferred for U.H.F. work.



Part No. 84-Z2-1

4 ft. coaxial cable (RG-8/U) for connecting Pulse Generator, Model 79-B, to the Model 80 Standard Signal Generator. This cable may also be used with pad 80-ZH1, as both ends of the cable are terminated in Navy Type 49195 connector plugs.

Adapter, AN Type UG-201/U

AN Type UG-201/U adapter for use with 80-ZH3 pad. One end of the adapter has a plug connector that fits the output jack of the pad; the other end has a BNC jack. This adapter may be used below 100 megacycles without the use of the pad.



IMPEDANCE MATCHING TRANSFORMER

MODEL M-286

The M-286 is a broad-band impedance matching transformer for matching a 72 ohm coaxial line to a 300 ohm balanced line. Frequency range: 40 to 220 Mc. For use with M-255 Pad.

NOTE: Since the transformer yields a voltage step-up of 1:2 and the M-255 Pad a voltage step-down of 2:1, the overall voltage ratio is 1:1.

M-255 MATCHING PAD

A 72 ohm pad with an AN Type UG-58/U (Navy Type 49470) output jack for matching 50 ohm output impedance of Model 80 to 72 ohm input of M-286 transformer.

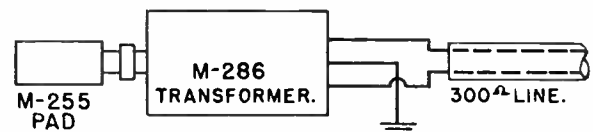
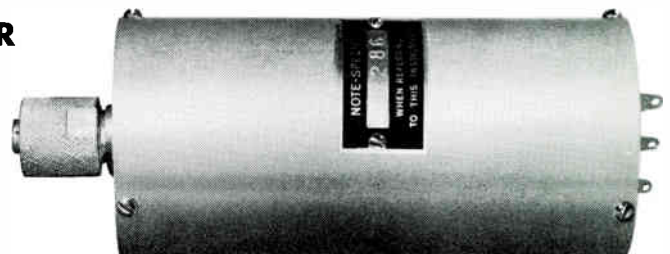

MODEL 58 ACCESSORIES

THE Accessories shown on this page are recommended for use with the Model 58 U.H.F. Radio Noise and Field Strength Meter but are not furnished as standard equipment with this instrument unless ordered.

HIGH IMPEDANCE PROBE

MODEL 58-Z12



This High Impedance Probe is a tunable transformer used for coupling the Model 58 to an external circuit or antenna for measuring rf voltage, transmission loss of various four-terminal networks and for determining the interference level on power lines, battery leads, etc.

CALIBRATION NETWORK

MODEL M-232

This network is convenient for coupling the Model 58 to a Model 80 Standard Signal Generator for r.f. and oscillator alignment and for sensitivity standardization. It consists of a special output pad for the Model 80 coupled by a short length of cable to a connector fitting the input terminals of the Model 58.

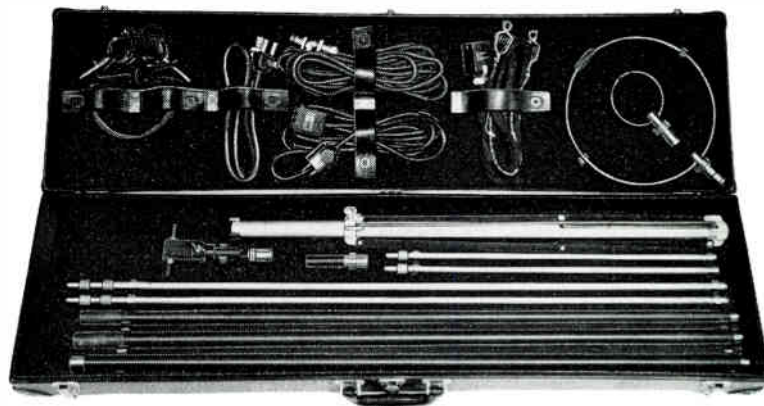

MODEL 58 KIT, CONSISTS OF:

Set of doublet antennas adjustable from 28 to 150 megacycles—permits the measurements of field intensity from 10 to 100,000 microvolts per meter at 150 megacycles; 1 to 60,000 microvolts per meter at 28 megacycles. Settings are engraved directly on the rods to indicate the correct length for a particular frequency—no yardstick or tape necessary for adjustment. Construction permits telescoping to about 3 feet for ease of transportation.

Tripod and stand for above antenna—designed to permit orientation of the antenna for measurement of either horizontally or vertically polarized waves—made of non-metallic materials to minimize errors from standing waves. Height extended, approximately 12 feet; collapsed for transportation, about 3 feet.

Loop probe antenna 3" diameter—interchangeable with the regular antennas. Designed for measuring the effectiveness of automobile or airplane ignition shielding. Indicates not only magnitude but also direction of current flow; thus speeding up the process of finding leaks and measuring the effectiveness of "bonding."

Capacity probe antenna for certain types of ignition noise investigation where space is very limited.

Antenna connector for attaching the instrument to transmission lines or other apparatus. Three terminals are provided with a three foot section of shielded cable and plug.

Pair of Trimm Featherweight headphones and plug.

Sturdy, fabricoid-covered carrying case designed to accommodate all of the above listed accessories and standard items. Size 4" x 10" x 40".

MODEL 90 ACCESSORIES

- 2—**Patch Cables:** Type 84-Z2-3, 4 ft. coaxial cables, RG-8/U (52 ohms), with both ends terminated in AN Type UG-21/U connector plugs.
- 1—**Output Pad:** Type M-289, a special matching pad, using two UG-21/U fittings, to provide a 300 ohm balanced matched output.
- 2—**Cables:** 3 ft. coaxial cables, RG-55/U, with one end terminated in an AN Type UG-22/U connector; the other end is terminated in an AN Type UG-23/U connector. (Dwg. A2736)
- 1—**Video Cable:** 4 ft. coaxial cable, RG-59/U (72 ohms), with both ends terminated in Navy Type 49195 connectors. (Dwg. A2735)
- 1—**Output Pad:** Type M-255, 72 ohm matching pad, with Navy Type 49470 output jack; for use with Type M-266 cable.
- 1—**Output Cable:** Type M-266, 4 ft. coaxial cable, RG-59/U (72 ohms), with one end terminated in a Navy Type 49268 connector; the other end is terminated with spade lugs.
- 1—**Output Cable:** Type 80-ZH4, 4 ft. coaxial cable, RG-55/U with one end terminated in an AN Type UG-21/U connector; the other end has a binding post termination.
- 1—**Termination:** Type M-292, Special 53 ohm termination to provide coaxial output, when balanced output is not required.
- 1—**Impedance Matching Transformer:** Type M-286 for matching 72 ohm coaxial cable to 300 ohm balanced line.

ACCESSORY EQUIPMENT RECOMMENDED FOR MODEL 90

MODEL 80 STANDARD SIGNAL GENERATOR

(See Page 17)

MODEL 71 SQUARE WAVE GENERATOR

(See Page 25)

MODEL 79-B PULSE GENERATOR

(See Page 23)



GENERAL INFORMATION

ORDERING: In the event an order is contemplated, it is suggested that the type number of the equipment be specified whenever possible. Otherwise describe the required item in detail in order that your requirements may be fully understood. Be sure to specify the power line voltage, if other than standard (117 volts). All orders should be made out to Measurements Corporation, Boonton, New Jersey, regardless of whether or not they are placed through a sales representative.

PRICES: All prices quoted are f.o.b. Boonton, New Jersey, unless otherwise specified in writing and are subject to change without notice. Formal written quotations will remain open for a thirty day period.

TERMS: 1% ten days, net thirty days, subject to the approval of our Credit Department. All payments are to be made at par in New York funds. In the event credit has not been established we reserve the right to effect shipment C.O.D.

SHIPPING INSTRUCTIONS: Unless specific instructions accompany the order, we shall use our best judgment as to the method of shipment. All equipment is packed for domestic shipment unless otherwise specified. Export packing charges will be given upon request.

DISCOUNTS: Our instruments are not subject to discount excepting in quantity purchases of 10 or more units. In the event a sizable order is contemplated it is suggested that our main office be contacted for the prevailing unit prices.

SALES REPRESENTATIVES: We have sales representatives throughout the United States who have had factory training and are available for the users of our equipment at all reasonable times. These men are located in the larger cities and are ready to serve our customers in the purchase of new units or will offer suggestions as to the solution of present problems with equipment at hand. While our agents are authorized to receive orders for purposes of transmittal, they have no authority to formally accept orders on behalf of the Company and any order that may be contemplated should be made out to Measurements Corporation, Boonton, New Jersey.

TAXES: Prices are subject to such additions for Federal, State or local taxes as we are now or may be required to collect, and to revision as to any sales or excise taxes which may hereafter be imposed and which must be included in the selling price.

SPECIFICATIONS: We reserve the right to discontinue instruments and to change specifications, without notice at any time without incurring any obligation to incorporate new features in instruments previously sold.

REPAIRS: When returning instruments for repair, recalibration, or for any other reason, please notify our Service Department well in advance of their return and specify the type number and serial number. To facilitate the repair of your instrument, a detailed description of the nature of the complaint should accompany the repair order or instrument. A special form for this purpose will be furnished on request. In many instances the owner of the instrument will require an exact quotation before authorizing the necessary repair work and a procedure has now been established whereby all units returned are carefully inspected, quotations made, and authorization given to proceed with the repairs. In certain cases, this method delays the user of the instrument; if you should desire the unit to be repaired without a definite quotation, please so specify on the repair order so that any necessary work may be expedited. Regardless of whether or not a quotation is submitted, the charges made will be as reasonable as possible, and will include time and materials required to place the instrument in satisfactory operating condition.

WARRANTY: We warrant all products manufactured or sold by us, with the exception of electronic tubes, to be free from defects in material and workmanship; said obligation under this warranty being limited to repairing or replacing any of our products which shall, within one year after delivery to the original purchaser, prove by our examination to be defective and which are returned to us, transportation charges prepaid.

Material delivered to you on order shall not be considered as defective or not in compliance with your order even though not in exact accordance with specifications, if it substantially fulfills performance requirements.

This warranty does not extend to any of our instruments which have been subject to misuse, neglect, accident, or improper installation or application, nor shall it extend to units which have been repaired or altered outside of our factory.

No return of parts will be accepted unless return has been previously authorized by us. This warranty is in lieu of all other warranties expressed or implied.



THE IMPORTANCE OF MATCHED IMPEDANCES IN SIGNAL GENERATOR MEASUREMENTS

Users of Signal Generators often question the true value of voltage developed across the input of the receiver under test. They are also confused when the apparent sensitivity appears to be a function of the generator with which the measurement is made.

Measurements made with different generators can usually be correlated if consideration is given to: (1) output impedance of the generator, (2) possibility of standing waves on the output cable, (3) effect of load impedance, (4) resonance in leads used to connect generator to load.

The output circuit of the modern signal generator is designed for use with a transmission line output cable. That is, the output terminals, instead of appearing on the front panel, are placed at the extremity of a coaxial cable thereby permitting the use of extremely short leads between generator and load. This cable functions as a transmission line and should be properly terminated at both ends for optimum performance.

Signal Generators are calibrated in terms of voltage appearing across the terminals of the output cable terminated by its characteristic impedance. The following examples will illustrate the errors that may be introduced by line characteristics and load impedances.

Figure 1 represents the equivalent circuit of a signal generator with step-type resistor attenuator and terminated output cable.

SIGNAL GENERATOR.

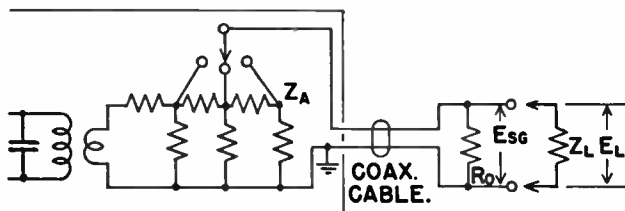

FIGURE 1

R_0 = Terminating resistor equal to characteristic impedance of output cable.

Z_A = Impedance of step attenuator

Z_{SG} = Parallel impedance of Z_A and R_0 and is referred to as the "output impedance of the generator".

Z_L = External load impedance

E_{SG} = Indicated open circuit voltage across R_0 .

E_L = Voltage developed across load impedance.

$$E_L = E_{SG} \frac{Z_L}{Z_{SG} + Z_L}$$

When $Z_L \gg Z_{SG}$, $E_L = E_{SG}$. When Z_L is comparable in magnitude to Z_{SG} , E_L will be less than E_{SG} .

It should be noted that when $Z_A = R_0$ the cable is properly terminated at both ends and the output impedance equals $\frac{R_0}{2}$ and will be substantially constant and independent of frequency. When Z_A does not equal R_0 the output impedance will vary with increasing frequency as the cable approaches quarter wavelength.

Let us now consider a mutual inductance attenuator, Figure 2.

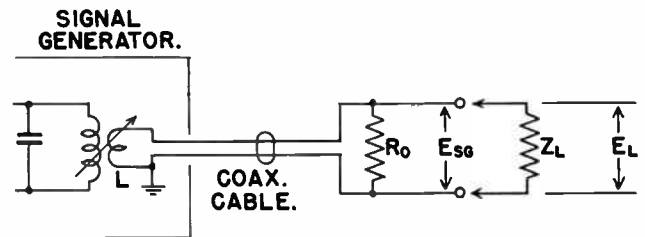

FIGURE 2

E_{SG} = Indicated open circuit voltage across R_0 .

Z_L = External Load impedance

Z_{SG} = Impedance seen looking into output terminals.

R_0 = Terminating resistor equal to characteristic impedance of output cable.

At low frequencies the reactance of the coupling coil L is usually negligible and Z_{SG} is very low. As the frequency is increased, however, the reactance of the cable, as viewed from the output terminals increases until the cable becomes a quarter wavelength line and theoretically appears as an open circuit. The output impedance then equals R_0 .

As in the previous case $E_L = E_{SG} \frac{Z_L}{Z_{SG} + Z_L}$. At the lower frequencies Z_{SG} is very small and for a given value of Z_L loading effect is not as noticeable as at the higher frequencies.

In order to overcome the effect of varying output impedance it is customary to terminate the output cable at both ends. This is accomplished at the generator end by

means of an impedance matching pad which isolates the coupling loop from the external cable. The pad is usually designed for a 2:1 voltage loss and the correction indicated by a "pad" fiducial mark on the attenuator dial.

The output impedance of the generator is now $\frac{R_0}{2}$ and the voltage across the output terminal is $\frac{E_{SG}}{2}$.

As the frequency is increased resonance effects will occur with even the shortest possible leads between the output terminals and Z_L . It then becomes desirable to design the input circuit of the equipment under test to match the characteristic impedance of the cable, thereby eliminating R_0 . Whenever the input circuit of the equipment is designed to match a line of different impedance from that supplied with the generator, a suitable pad can be designed to match the generator to the new line.

It is often possible to improvise suitable resistance pads from non-inductive carbon resistors using the shortest possible leads. Simple T pads can be computed from hand book formulas.

They can be calculated on the basis of a simple voltage attenuation ratio such as 2:1 making it convenient to apply a corresponding correction factor to the indicated voltage.

Figure 3 shows an example of a T pad used to match a 50 ohm cable to a 72 ohm receiver.

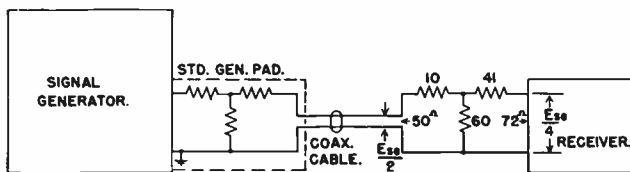

FIGURE 3

The resistor values given have been computed to match 50 to 72 ohms with a 2:1 drop in voltage (corresponding to 5.7:1 power ratio).

USE OF DUMMY ANTENNAS

Allowance should be made for the output impedance of the signal generator when testing a receiver through a dummy antenna. Recommended methods for connecting the generator to the receiver are shown in Figure 4.

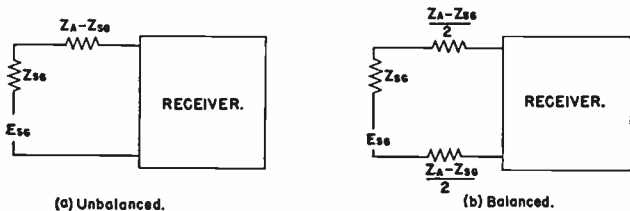

FIGURE 4

- E_{SG} = Indicated voltage of signal generator
- Z_{SG} = Output impedance of signal generator (when properly terminated)
- Z_A = Specified antenna impedance.

The output circuit of most signal generators is unbalanced to ground and when the input circuit of the receiver is also unbalanced, the connection shown in Figure 4a is satisfactory. When the receiver input is balanced to ground and the value of $Z_A - Z_{SG}$ is considerably higher than the internal impedance of the generator, the circuit of Figure 4b can be used. The effect of unbalance, usually negligible, may be checked by reversing the connections at the receiver and averaging the two readings.

For measurements at very high frequencies, special transformers for matching unbalanced to balanced lines are available. These are especially recommended for use when testing FM and TV receivers.

For some purposes it is desirable to consider the applied voltage as being supplied by a source impedance Z_0 as shown in Figure 5. Then the driving voltage E_0 may

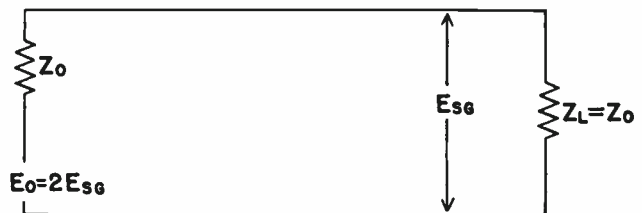

FIGURE 5

be considered as equal to twice the indicated voltage, E_{SG} . This concept of driving voltage is convenient when determining the noise factor of receivers. It is also useful for calibrating field strength measuring receivers in terms of the voltage induced in the antenna.

PRECAUTIONS

The signal generator is capable of making accurate measurements when used correctly. A careful analysis of test connections should always be made and the limitations of the generator considered. A pad should be used whenever possible and output cables should always work into a matched load for greatest accuracy of measurement. Where this is not possible, measurement data should be corrected as has been shown above.

Attenuators offer low impedance to power line voltages. Particular care should be observed when testing AC-DC receivers to isolate test leads with capacitors to avoid damage to the attenuator circuits.

REACTANCE CHART

