

DIALIGHT

MANUFACTURERS OF VISUAL INDICATORS

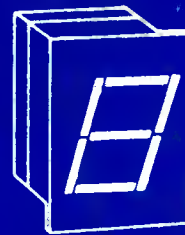

**INDICATOR
LIGHTS**



READOUTS

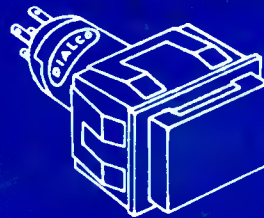

SWITCHES

A NORTH AMERICAN PHILIPS COMPANY

DIALIGHT

MANUFACTURERS OF VISUAL INDICATORS



**INDICATOR
LIGHTS**

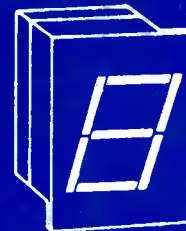

READOUTS



DIALIGHT

MANUFACTURERS OF VISUAL INDICATORS



**INDICATOR
LIGHTS**

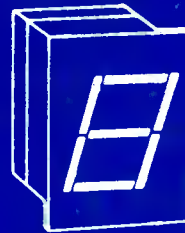

READOUTS

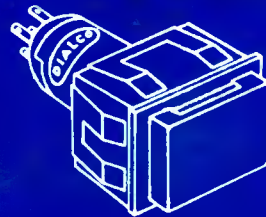

SWITCHES

A NORTH AMERICAN PHILIPS COMPANY

DIALIGHT

MANUFACTURERS OF VISUAL INDICATORS

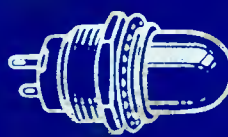

**INDICATOR
LIGHTS**

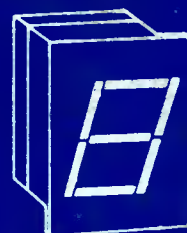

READOUTS

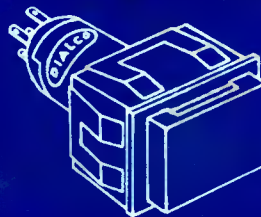

SWITCHES

A NORTH AMERICAN PHILIPS COMPANY

DIALIGHT

MANUFACTURERS OF VISUAL INDICATORS

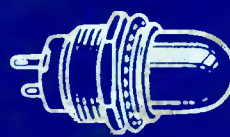

**INDICATOR
LIGHTS**

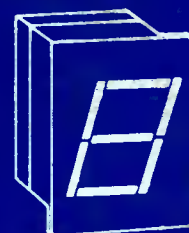

READOUTS

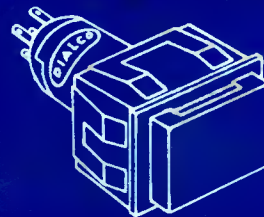

SWITCHES

A NORTH AMERICAN PHILIPS COMPANY

SERIES NUMBER	SIZE OR PRODUCT GROUP	CATALOG NUMBER	SECTION NUMBER	TAB DIVIDER
402-	Lens Cap	L-161	7	Miniature, Large & Misc. Indicators
502-	Open Type Assembly	L-161	7	Miniature, Large & Misc. Indicators
503-	Lamp Socket	CR680	3	Dialco Military Cross Reference
507-	Ultra-Miniature	UM1200	5	Ultra-Miniature Indicator Lights
		SG751	11	LED Diode-Lites
508-	Ultra-Miniature	UM1200	5	Ultra-Miniature Indicator Lights
513-	Switch	L-210	14	Switches
514-	Lens Cap	L-161	7	Miniature, Large & Misc. Indicators
515-		UM1200	5	Ultra-Miniature Indicator Lights
		L-210	14	Switches
520-	Placard Light	L-170	12	Placard Lights
		CR740	3	Dialco Military Cross Reference
521-	Lamp	SG751	11	LED Diode-Lites
		LS7010	15	Lamps
		LS7101	15	Lamps
533-	Switch	L-210	14	Switches
534-	Push Button Cap	L-210	14	Switches
538-	Snap-in Neon Indicator	L-211	7	Miniature, Large & Misc. Indicators
539-	Flasher	L-211	7	Miniature, Large & Misc. Indicators
545-	Switch	SW6120	14	Switches
546-	Switch	SW6120	14	Switches
547-	LED Indicator	SG751	11	LED Diode-Lites
549-	LED	SG751	11	LED Diode-Lites
550-	LED Indicator	SG751	11	LED Diode-Lites
551-	Opto-Isolator	SG751	11	LED Diode-Lites
554-	Switch	SW6130	14	Switches
555-	LED Indicator	SG751	11	LED Diode-Lites
556-	LED Status Indicator	SG751	11	LED Diode-Lites
557-	LED Status Indicator	SG751	11	LED Diode-Lites
558-	LED Indicator	SG751	11	LED Diode-Lites
559-	LED Indicator	SG751	11	LED Diode-Lites
704-	Readout	SG742	13	Readouts
710-	Readout	SG742	13	Readouts
711-	Readout	SG742	13	Readouts
712-	Readout	SG742	13	Readouts
713-	Readout	SG742	13	Readouts
730-	Readout	SG751	11	LED Diode-Lites
739-	Readout	SG751	11	LED Diode-Lites
740-	Readout	SG751	11	LED Diode-Lites
745-	Readout	SG751	11	LED Diode-Lites
749-	Readout	SG742	11	LED Diode-Lites
755-	Readout	SG742	11	LED Diode-Lites
800-	Press-to-Test	L-201	9	Press-to-Test Indicator Lights
801-	Press-to-Test	L-201	9	Press-to-Test Indicator Lights
		CR740	3	Dialco Military Cross Reference
803-	Press-to-Test	L-201	9	Press-to-Test Indicator Lights
		CR740	3	Dialco Military Cross Reference
804-	Press-to-Test	L-201	9	Press-to-Test Indicator Lights
		CR740	3	Dialco Military Cross Reference
806-	Press-to-Test	L-201	9	Press-to-Test Indicator Lights
808-	Press-to-Test	L-201	9	Press-to-Test Indicator Lights
809-	Press-to-Test	L-201	9	Press-to-Test Indicator Lights
810-	Press-to-Test	L-201	9	Press-to-Test Indicator Lights
811-	Press-to-Test	L-201	9	Press-to-Test Indicator Lights
812-	Press-to-Test	L-201	9	Press-to-Test Indicator Lights
813-	Press-to-Test	L-201	9	Press-to-Test Indicator Lights
911-	Indicator	L-210	14	Switches
913-	Switch	L-210	14	Switches
915-	Ultra-Miniature	UM1200	5	Ultra-Miniature Indicator Lights
922-	Switch	L-210	14	Switches

DIALIGHT

Catalog and Product Data Guide

This guide will aid you in finding the desired data in this catalog binder.

To locate a specific catalog: Consult the chart below. It will direct you to the specific Tab Divider and desired catalog.

To obtain data on a specific indicator series: Consult the following pages. Series numbers are listed in numerical order. Each listing provides the catalog(s) describing the item and behind which Tab Divider the catalog may be found.

Military Type Designations are also listed: Dialight part numbers are given for each. Appropriate catalog and tab divider reference as listed for quick location.

CATALOG NUMBER	SECTION NUMBER	TAB DIVIDER *
L-168	4	SUB-SUB-MINIATURE INDICATOR LIGHTS
UM1200	5	ULTRA-MINIATURE INDICATOR LIGHTS
L-157 L-158 L-178	6	SUB-MINIATURE INDICATOR LIGHTS
L-161 L-211	7	MINIATURE, LARGE & MISC. INDICATORS
L-200	8	OIL-TIGHT INDICATOR LIGHTS
L-201	9	PRESS-TO-TEST INDICATOR LIGHTS
SG751	11	LED DIODE-LITES
L-170	12	PLACARD LIGHTS
SG742	13	READOUTS
L-210 SW6120	14	SWITCHES
LS7010 LS7101	15	LAMPS

*In some instances, tab dividers do not have numbers.

MILITARY TYPE DESIGNATIONS

MS NUMBER	DESCRIPTION	CATALOG NUMBER	SECTION NUMBER	TAB DIVIDER
18235	Plug-in Lamp Cartridge	UM1200	5	Ultra-Miniature Indicator Lights
		CR740	3	Dialco Military Cross Reference
18236	Plug-in Lamp Cartridge	UM1200	5	Ultra-Miniature Indicator Lights
		CR740	3	Dialco Military Cross Reference
18237	Plug-in Lamp Cartridge	UM1200	5	Ultra-Miniature Indicator Lights
		CR740	3	Dialco Military Cross Reference
18238	Plug-in Lamp Cartridge	UM1200	5	Ultra-Miniature Indicator Lights
		CR740	3	Dialco Military Cross Reference
MS25010	Edge Lighting for Plastic Panels	L-158	6	Sub-Miniature Indicator Lights
		CR740	3	Dialco Military Cross Reference
MS25041	Press-to-Test	L-201	9	Press-to-Test Indicator Lights
		CR740	3	Dialco Military Cross Reference
MS25256	Sub-Miniature -- Two Terminals	L-178	6	Sub-Miniature Indicator Lights
		CR740	3	Dialco Military Cross Reference
MS25257	Sub-Miniature -- Two Terminals	L-178	6	Sub-Miniature Indicator Lights
		CR740	3	Dialco Military Cross Reference
MS25331	Press-to-Test	L-201	9	Press-to-Test Indicator Lights
		CR740	3	Dialco Military Cross Reference
MS25446	Sub-Sub-Miniature	L-168	4	Sub-Sub-Miniature Indicator Lights
		CR740	3	Dialco Military Cross Reference
MIL-L-3661B: LC11-LC37 LH50-LH92 LHC81-LHC85		CR740	3	Dialco Military Cross Reference

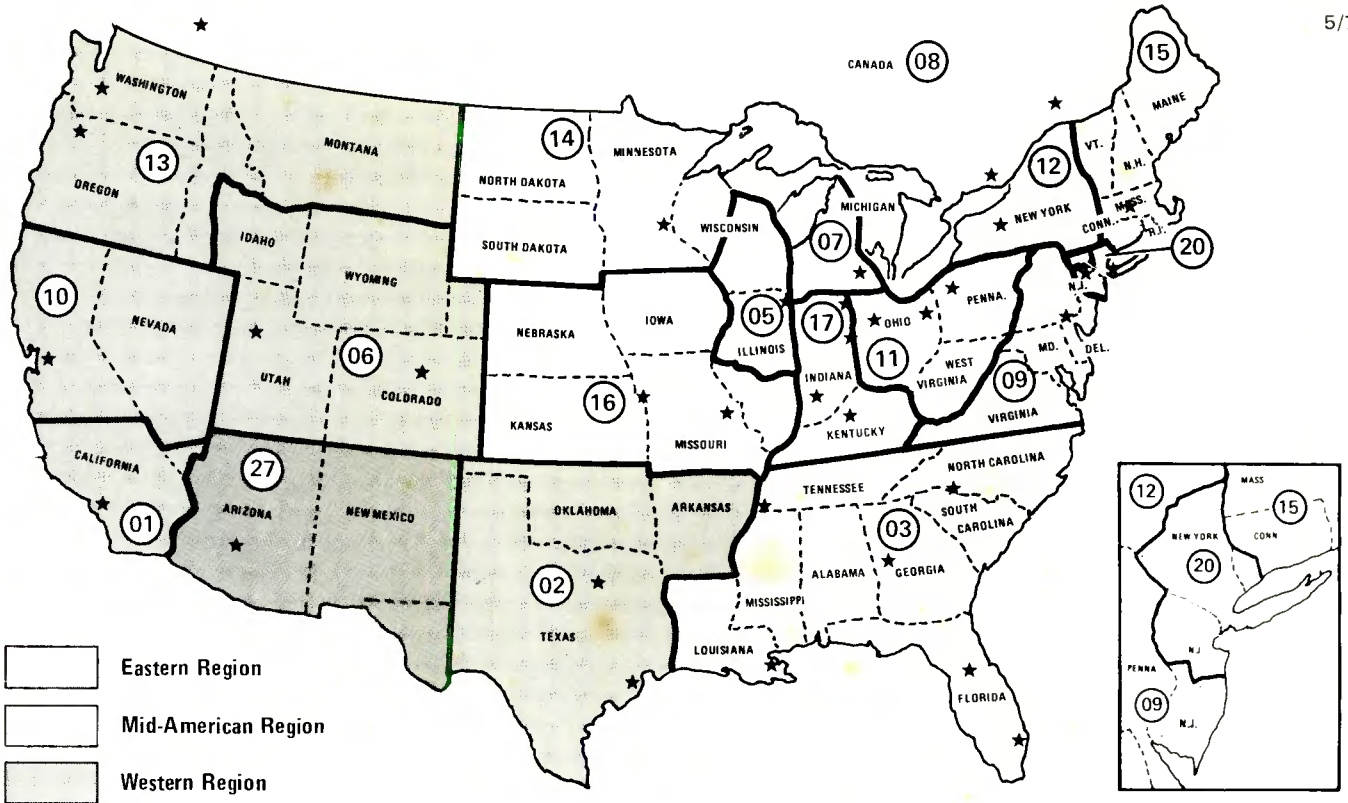

DIALIGHT sales representatives

01 Westrep
 9519 Telegraph Road
 Pico Rivera, Calif. 90660
 phone: (213) 949-2551

02 TESCO
 1401 K South Floyd Road
 Richardson, Texas 75080
 phone: (214) 690-4004

TESCO
 10212 Georgibelle Drive
 Houston, Texas 77043
 phone: (713) 464-2828

03 Cartwright & Bean Inc.
 560 S. Cooper
 P.O. Box 4760, Crosstown Sta.
 Memphis, Tenn. 38104
 phone: (901) 276-4442

Cartwright & Bean Inc.
 90 W. Wieuca Sq.
 Atlanta, Georgia 30342
 phone: (404) 255-5262

Cartwright & Bean Inc.
 1241 N.W. 75 Terrace
 Plantation, Florida 33313
 phone: (305) 791-3989

Cartwright & Bean Inc.
 200 E. Marks St.
 Orlando, Florida 32803
 phone: (305) 422-4531

Cartwright & Bean Inc.
 617 West Judge Perez Drive
 P.O. Box 1188
 Chalmette, La. 70043
 phone: (504) 279-4598

Cartwright & Bean Inc.
 625 Harwyn Drive
 Charlotte, N.C. 28215
 phone: (704) 333-6457

05 Hill-Gray Associates Inc.
 120 E. Ogden Avenue
 P.O. Box 250
 Hinsdale, Illinois 60521
 phone: (312) 325-4810

06 R.G. Bowen Co. Inc.
 1440 S. Santa Fe
 Denver, Colo. 80223
 phone: (303) 722-4641

Salt Lake City, Utah
 phone: (801) 363-8801

07 Hilltronics Inc.
 380 Hilton Road
 Ferndale, Michigan 48220
 phone: (313) 398-5556

08 Lake Engineering Co., Ltd.
 123 Manville Road
 Scarborough, Ontario
 phone: (416) 751-5980

Lake Engineering Co., Ltd.
 1061 DeCarie Blvd.
 St. Laurent, 381, Quebec
 phone: (514) 747-2441

Lake Engineering Co., Ltd.
 884 Minler Road
 Richmond, B.C.
 phone: (604) 277-0414

- | | | |
|---|--|--|
| <p>09 L.D. Lowery, Inc.
2801 West Chester Pike
Broomall, Pa. 19008
phone: (215) 528-5170</p> <p>L.D. Lowery, Inc.
5801 Annapolis Road
Bladensburg, Md. 20710
phone: (301) 277-6565</p> <p>10 Moulthrop Sales Inc.
1530 East 12th Street
Oakland, California 94606
phone: (415) 261-7676</p> <p>11 K W Electronics Sales, Inc.
8514 N. Main Street
Dayton, Ohio 45415
phone: (513) 890-2150</p> <p>K W Electronic Sales, Inc.
3439 W. Brainard Road
Cleveland, Ohio 44122
phone: (216) 831-8292</p> <p>K W Electronic Sales, Inc.
4025 William Flynn Hwy.
Allison Park, Penna. 15101
phone: (412) 487-4300</p> | <p>12 Precision Sales, Inc.
223 Taft Road
No. Syracuse, N.Y. 13212
phone: (315) 458-2223</p> <p>13 Almac/Stroum Electronics
5811 Sixth Avenue So.
Seattle, Washington 98108
phone: (206) 763-2300</p> <p>Almac/Stroum Electronics
Westhills Mall
4475 Scholls Ferry Road
Portland, Oregon 97225
phone: (503) 292-3534</p> <p>14 R.G. Ragon, Inc.
1136 W. Larpenteur Avenue
St. Paul, Minnesota 55113
phone: (612) 488-0201</p> <p>15 Mullin Technical Sales Co., Inc.
945 Great Plain Avenue
Needham, Mass. 02192
phone: (617) 444-4780</p> | <p>16 K & M Sales Company
5460 Buena Vista Dr.
Shawnee Mission, Kansas 66205
phone: (913) 262-1444</p> <p>K & M Sales Company
4969 Bancroft
St. Louis, Missouri 63109
phone: (314) 423-2420</p> <p>17 Southern Sales Corp.
5335 No. Tacoma Ave.
Indianapolis, Indiana 46220
phone: (317) 257-7575</p> <p>20 Dialight
203 Harrison Place
Brooklyn, N.Y. 11237
phone: (212) 497-7600</p> <p>27 Ralph Stitzer Co.
8808 North Central Avenue
Phoenix, Ariz. 85021
phone: (602) 944-6808</p> |
|---|--|--|

regional sales offices

EASTERN REGION & CANADA

Dialight
203 Harrison Place
Brooklyn, N.Y. 11237
phone: (212) 497-7600

MID-AMERICAN REGION

Dialight
823 Commerce Drive
Oakbrook, Illinois 60521
phone: (312) 323-1456

WESTERN REGION

Dialight
4676 Admiralty Way
Marina Del Rey, Calif. 90291
phone: (213) 821-3660

EXPORT: Contact **Dialight** Brooklyn, New York



DIALIGHT

INDICATOR LIGHT SELECTOR GUIDE

INCANDESCENT ■ NEON ■ LED

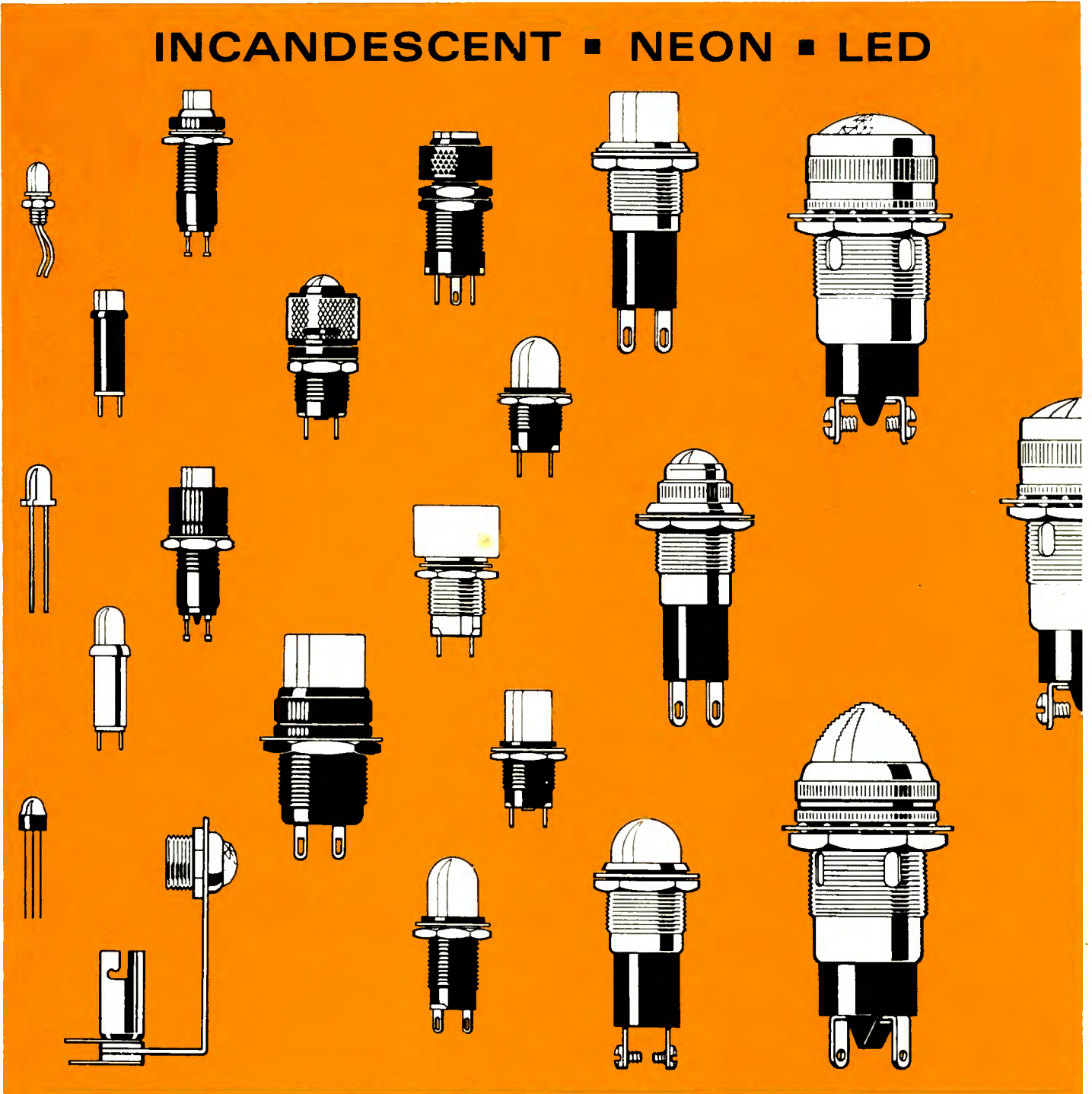

A NORTH AMERICAN PHILIPS COMPANY

How to use the Indicator Light Selector Guide

More than 1,500,000 indicator lights are presented in the Indicator Light Selector Guide by sections. Each section is devoted to indicators by either size or product groups. By consulting the appropriate section, you can ob-







tain helpful data. . . and a reference to the specific detailed catalog where necessary specifications and ordering information may be obtained. To request the desired catalog(s), fill-out the postage free return card found within this guide.

Note 1: Illustrations are for reference only. In some cases, features may vary slightly i.e. terminals, length or diameter may differ from illustrations shown. Series numbers are not to be used for ordering. Consult catalogs shown on right side of tabulation for complete ordering information.

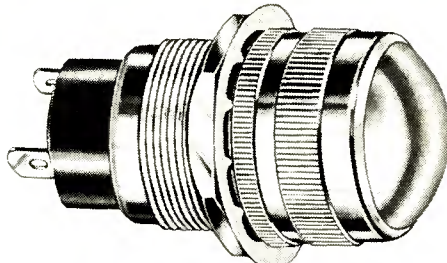
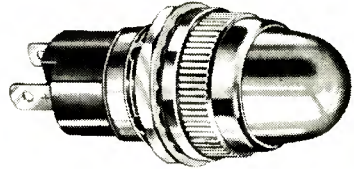
Three indexes are given to assist you in finding the desired indicators quickly and easily:

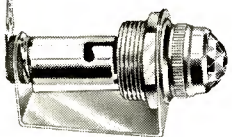
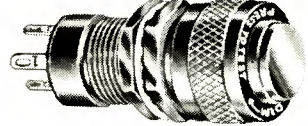
- 1- Index of Size and Product Groups w/MIL-SPEC REFERENCES
- 2- Index of Series Numbers in Numerical Order
- 3- Index of lamps

INDEX OF SIZE AND PRODUCT GROUPS

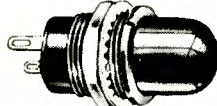
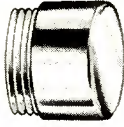
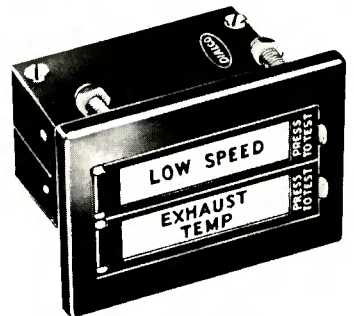
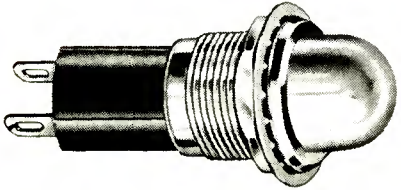
<p>1</p>  <p>Sub-Sub Miniatures</p>	<p>5</p>  <p>Large</p>	<p>9</p>  <p>Oil-Tights</p>
<p>2</p>  <p>Ultra-Miniatures</p>	<p>6</p>  <p>Open Type Indicators</p>	<p>10</p>  <p>Press-To-Test</p>
<p>2</p>  <p>Ultra-Miniatures</p>	<p>7</p>  <p>Flashers</p>	<p>11</p>  <p>Transistorized Indicators</p>
<p>3</p>  <p>Sub-Miniatures</p>	<p>8</p>  <p>Lens Caps</p>	<p>12</p>  <p>Placard Lights</p>
<p>4</p>  <p>Miniatures</p>		

MOUNTING HOLE SIZES

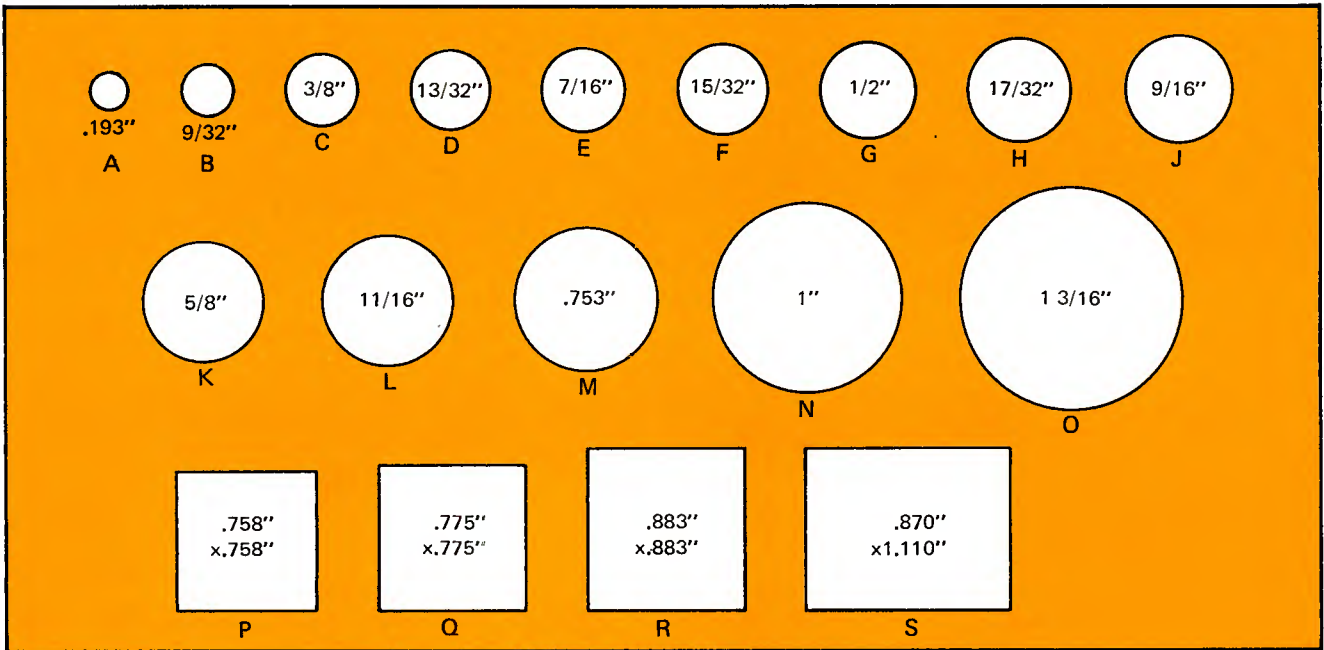

SIZE OR PRODUCT GROUPING	MOUNTING HOLE SIZES	MILITARY TYPE DESIGNATION		SEE PAGE NOS.
		MIL-SPEC	MIL-TYPE	
1 Sub-Sub Miniatures	A	MIL-SPEC MIL-6723B	MIL-TYPE MS25446	13
2 Ultra-Miniatures	C	MIL-SPEC MIL-L-3661B	MIL-TYPES MS18235 MS18236 MS18237 MS18238	13-17
3 Sub-Miniatures	D F G H M, P, R, S	MIL-SPEC MIL-7806 MIL-L-6723B	MIL-TYPES MS25010 MS25256 MS25257	18-24 53-54
4 Miniatures	E J L			25-35
5 Large	N			36-41
6 Open Type Indicators	B E L N			42-43
7 Flashers	Q			43
8 Lens Caps	—			44-45
9 Oil-Tights	L N O			46-49
10 Press-To-Test	F K N	MIL-SPECS MIL-L-7961B	MIL-TYPE MS25041 MS25331	50-51
11 Transistorized Indicators	C F			51
12 Placard Lights	Panel arrangement determined by stacking arrangement.			52

Glossary of Typical Lens Caps and Terminals Referenced in this Catalog.

lens shapes

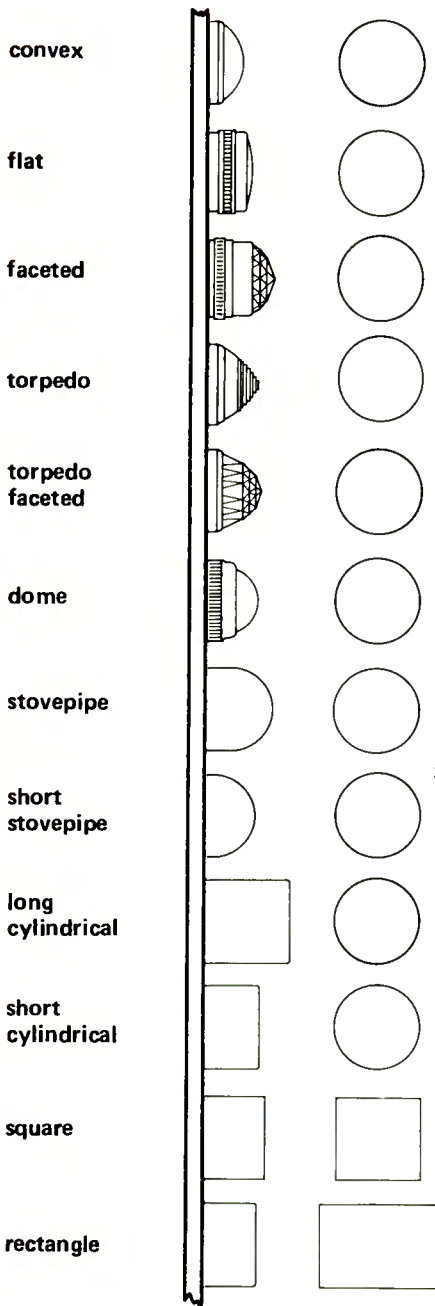

lens shape choices

1. Hollow back lenses such as **Dome, Stovepipe, Torpedo** or **Cylindrical** are preferred when good side angle visibility is required or for use with low light emitting lamps for maximum light output.
2. Flat back lenses such as **Convex, Flat** or **Faceted** would be used where low profile presentations are required. **Flat** and/or **Convex** lenses would be used when a legend disc is supplied behind the lens. **Flat** or **Cylindrical** lenses only would be used when legend is supplied hot-stamped or engraved and filled on the face of the lens.
3. **Faceted** lenses or **Internally Fluted** lenses are suggested where omnidirectional dispersment of light is required.

lens colors

- red
- *green
- yellow (amber)
- *blue
- white (translucent)
- light yellow
- clear (colorless)

*not recommended for use with neon light sources.

legends

Various lens cap shapes are available with **letters, numbers, words** or **symbols** to convey required indication. Depending on the particular lens caps and usage, legends may be hot-stamped, engraved or produced photographically on film or parchment. The latter three may be had with either positive or negative reading presentations.

terminals

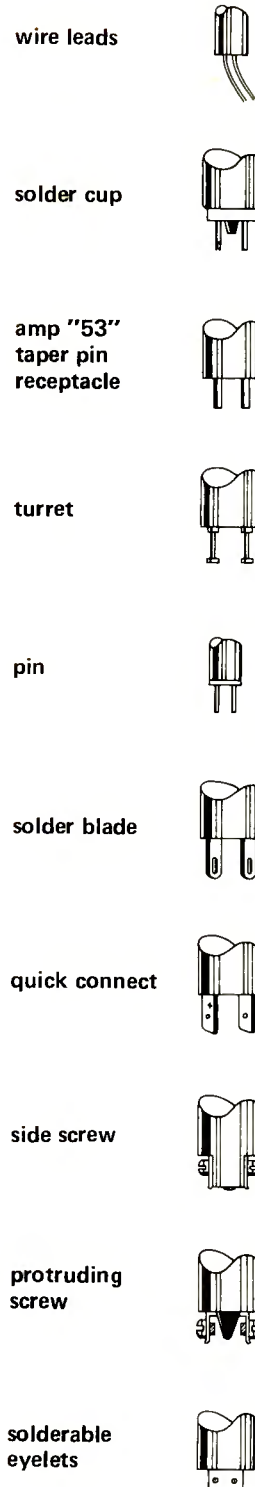

Index of Series Numbers in Numerical Order

SERIES	SIZE OR PRODUCT GROUP	SEE PAGE NO
2-	Sub-Miniature	18
3-	Sub-Miniature	18
4-	Sub-Miniature	18
8-	Sub-Miniature	19
11-	Sub-Miniature	19
17-	Miniature	25,31
19-	Large	36,37
21-	Miniature	25
22-	Miniature	25
26-	Miniature	26,31
31-	Large; Lens Cap	37,38,39,41 44
33-	Miniature	26
34-	Lens Cap	44
37-	Miniature	26,31
47-	Large	37
49-	Large	37
50-	Large	37,38
51-	Large	38,41
52-	Miniature	26,32
55-	Miniature	26
61-	Large	38,39
70-	Miniature	27,32
78-	Large	39
80-	Large	39,41
81-	Miniature; Lens Cap	27,32,33 44
85-	Miniature	27,33
89-	Miniature	27
90-	Miniature	27
93-	Miniature	28
95-	Miniature; Lens Cap	28,33,34 44
101-	Sub-Miniature	19
103-	Oil-Tight	46,47,48

SERIES	SIZE OR PRODUCT GROUP	SEE PAGE NO
104-	Oil-Tight	47
105-	Miniature	28
106-	Sub-Miniature	19
107-	Sub-Miniature	19
108-	Sub-Miniature	19
109-	Sub-Miniature	20
111-	Sub-Miniature	20
112-	Sub-Miniature	20
113-	Sub-Miniature	20
115-	Oil-Tight	47
116-	Oil-Tight	47
123-	Oil-Tight	47,49
124-	Oil-Tight	47
125-	Oil-Tight	48,49
126-	Miniature	28
129-	Miniature	28
132-	Miniature; Lens Cap	28,34 44
134-	Sub-Miniature	20
135-	Miniature; Lens Cap	29,34,35 44
137-	Sub-Miniature	23,24
138-	Sub-Miniature	24
140-	Sub-Miniature	20
145-	Sub-Miniature	24
151-	Large	39,40
154-	Large	40
156-	Miniature	29
159-	Oil-Tight	49
162-	Sub-Miniature	21

Index of Series Numbers in Numerical Order

SERIES	SIZE OR PRODUCT GROUP	SEE PAGE NO.
169-	Miniature	29,35
174-	Sub-Miniature	21
175-	Sub-Miniature	21
177-	Sub-Miniature	21
178-	Sub-Miniature	21
179-	Lens Cap	54
181-	Sub-Miniature	24
182-	Lens Cap	54
183-	Lens Cap	54
183-9730	Sub-Miniature	21,53
183-9830	Sub-Miniature	21,53
184-	Lens Cap	54
184-9730	Sub-Miniature	21
184-9830	Sub-Miniature	21
185-	Lens Cap	54
185-9730	Sub-Miniature	21
185-9830	Sub-Miniature	21
186-	Lens Cap	54
186-9730	Sub-Miniature	22
186-9830	Sub-Miniature	22
187-	Lens Cap	54
187-9730	Sub-Miniature	22
187-9830	Sub-Miniature	22
188-	Lens Cap	54
188-9730	Sub-Miniature	22
188-9830	Sub-Miniature	22
190-	Lens Cap	54
190-9730	Sub-Miniature	22
190-9830	Sub-Miniature	22
191-	Lens Cap	54
191-9730	Sub-Miniature	22
191-9830	Sub-Miniature	22
192-	Lens Cap	54

SERIES	SIZE OR PRODUCT GROUP	SEE PAGE NO.
199-	Lens Cap	54
203-	Miniature	29
204-	Miniature	30
207-	Miniature	30
208-	Miniature	30
209-	Large	40
210	Large	40
215-	Oil-Tight	48
216-	Oil-Tight	48
218-	Oil-Tight	48
220-	Miniature	30
221-	Miniature	30
222-	Miniature	30
223-	Sub-Miniature	22
225-	Large	40
249-	Ultra-Miniature	14,16
250-	Ultra-Miniature	14,16
251-	Ultra-Miniature	14
252-	Sub-Sub-Miniature	13
253-	Ultra-Miniature	15
270-	Sub-Miniature	22
271-	Sub-Miniature	22
272-	Sub-Miniature	23
273-	Sub-Miniature	23
274-	Sub-Miniature	23
300-	Lens Cap	54
301-	Lens Cap	54
303-	Lens Cap	54
304-	Lens Cap	54
305-	Lens Cap	54
306-	Lens Cap	54

Index of Series Numbers in Numerical Order

SERIES	SIZE OR PRODUCT GROUP	SEE PAGE NO.
307-	Lens Cap	54
359-	Sub-Miniature	23
360-	Sub-Miniature	23
361-	Sub-Miniature	24
362-	Sub-Miniature	23
363-	Sub-Miniature	23
364-	Sub-Miniature	24
365-	Ultra-Miniature	15
366-	Sub-Miniature	24
367-	Sub-Miniature	23
368-	Sub-Miniature	23
369-	Sub-Miniature	23
370-	Ultra-Miniature	15
371-	Ultra-Miniature	15
372-	Open Type Indicator	42
373-	Miniature	30,35
375-	Miniature	30,35
376-	Miniature	30,35
377-	Miniature	30,35
378-	Large	41
379-	Large	41
380-	Large	41
381-	Large	41
402-	Lens Cap	44
502-	Open Type Indicator	42,43
503-	Socket Assembly	45
507-	Ultra-Miniature	17
508-	Ultra-Miniature	15
510-	Data Strip®	15
511-	Data Strip®	15
512-	Data Matrix®	15
513-	Switches	55
514-	Lens Cap	44,45

SERIES	SIZE OR PRODUCT GROUP	SEE PAGE NO.
515-0012	Cartridge Connector	15
515-0050	Cartridge Connector	15
515-0051	Speed Clip	15
515-0074	Cartridge Connector	15
515-0300	Kap-Kover®	54
520-	Placard Lights	52
521-	LED Lamps	12
533-	Matching Indicator	53
534-	Push Button Cap	54
538-	Matching Indicator	43
539-	Flashing Indicator	43
545-	Thumbwheel Switches	55
546-	Thumbwheel Acces.	55
547-	LED Logic/State Fault Indicator	13
549-	LED Bi-Pin Lamps	12
550-	LED Logic/State Fault Indicator	13
551-	Opto-Isolators	55
555-	LED Logic/State Fault Indicator	13
700 series	Readouts	55
800-	Press-to-Test	50
801-	Press-to-Test	50
803-	Press-to-Test	50
804-	Press-to-Test	50
806-	Press-to-Test	50
808-	Press-to-Test	50
809-	Press-to-Test	50
810-	Press-to-Test	51
811-	Press-to-Test	51
812-	Press-to-Test	51
813-	Press-to-Test	51
901-	Transistorized Indicator	51
903-	Transistorized Indicator	51
907-	Transistorized Indicator	51
911-	Ultra-Miniature	16
913-	Switches	55
915-	Ultra-Miniature	16
922-	Switches	55

LAMP INDEX

INCANDESCENT

Incandescent Lamps are available in a wide range of voltages and specifications. They generally have a high light output and can be used with any color lens.

When reliability is important, it is advantageous to use low voltage lamps which have shorter, thicker filaments and are, therefore, inherently stronger.

Ratings of lamps are taken from published catalogs of leading lamp manufacturers.





Rated life is generally recognized as the 50% failure point of a group of lamps tested under static laboratory conditions, with the voltage closely regulated at the design value.

The rated life may not necessarily agree with the service life of a lamp

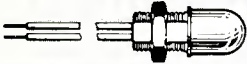
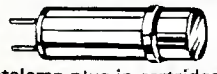

where the effects of temperature, shock, vibration and voltage fluctuations may result in a shorter than rated life.

Light output and life depend upon the voltage at which the incandescent lamp is operated. As the voltage is varied from its design value, current, life and light output also vary. For example, at 10% overvoltage, current increases 5%, light output 40% and life is reduced to about 35% of that at design voltage. Conversely, operation at 90% of design voltage reduces current to 95%, light output to 70% and increases life to 4 times that at design voltage.

Lamp choice should be made before design is frozen, so that a lamp well suited for the product may be selected. All Dialight indicator lights are designed to produce the greatest effectiveness with all lamp types.

LAMP	MANUFACTURER'S RATINGS	ACCOMMODATED BY INDICATOR LIGHTS DESCRIBED IN SECTION(S):	SEE PAGE NOS.																																																																																																																
 <p>T-1</p>	<table border="1"> <thead> <tr> <th>VOLTS</th> <th>AMPS</th> <th>HOURS</th> </tr> </thead> <tbody> <tr> <td>5.0</td> <td>0.06</td> <td>60,000</td> </tr> <tr> <td>6.3</td> <td>0.07</td> <td>6,000</td> </tr> </tbody> </table>	VOLTS	AMPS	HOURS	5.0	0.06	60,000	6.3	0.07	6,000	<ul style="list-style-type: none"> • Sub-Sub-Miniatures 	13																																																																																																							
VOLTS	AMPS	HOURS																																																																																																																	
5.0	0.06	60,000																																																																																																																	
6.3	0.07	6,000																																																																																																																	
 <p>T-1 3/4 Datalamp plug-in cartridges</p>	<table border="1"> <thead> <tr> <th>LAMP NO.</th> <th>VOLTS</th> <th>AMPERES</th> <th>HOURS</th> <th>CANDLE POWER</th> </tr> </thead> <tbody> <tr><td>331</td><td>1.35</td><td>.06</td><td>5,000</td><td>.006</td></tr> <tr><td>338</td><td>2.7</td><td>.06</td><td>6,000</td><td>.04</td></tr> <tr><td>375</td><td>3.0</td><td>.015</td><td>20,000</td><td>.004</td></tr> <tr><td>521-9057</td><td>5.0</td><td>.03</td><td>10,000</td><td>.02</td></tr> <tr><td>521-9058</td><td>5.0</td><td>.03</td><td>10,000</td><td>.02</td></tr> <tr><td>7332</td><td>5.0</td><td>.06</td><td>30,000</td><td>.05</td></tr> <tr><td>*328</td><td>6.0</td><td>.20</td><td>1,000</td><td>.63</td></tr> <tr><td>345</td><td>6.0</td><td>.04</td><td>1,000</td><td>.03</td></tr> <tr><td>349</td><td>6.3</td><td>.20</td><td>5,000</td><td>.55</td></tr> <tr><td>380</td><td>6.3</td><td>.04</td><td>20,000</td><td>.02</td></tr> <tr><td>381</td><td>6.3</td><td>.20</td><td>20,000</td><td>.40</td></tr> <tr><td>344</td><td>10.0</td><td>.014</td><td>25,000</td><td>.002</td></tr> <tr><td>367</td><td>10.0</td><td>.04</td><td>10,000</td><td>.08</td></tr> <tr><td>330</td><td>14.0</td><td>.08</td><td>1,500</td><td>.50</td></tr> <tr><td>382</td><td>14.0</td><td>.08</td><td>15,000</td><td>.30</td></tr> <tr><td>370</td><td>18.0</td><td>.04</td><td>10,000</td><td>.15</td></tr> <tr><td>*327</td><td>28.0</td><td>.04</td><td>4,000</td><td>.34</td></tr> <tr><td>**387</td><td>28.0</td><td>.04</td><td>7,000</td><td>.30</td></tr> </tbody> </table> <p>△ Bi-Pin Base *Conforms to MS25237 **MS18209 (BuShips)</p>	LAMP NO.	VOLTS	AMPERES	HOURS	CANDLE POWER	331	1.35	.06	5,000	.006	338	2.7	.06	6,000	.04	375	3.0	.015	20,000	.004	521-9057	5.0	.03	10,000	.02	521-9058	5.0	.03	10,000	.02	7332	5.0	.06	30,000	.05	*328	6.0	.20	1,000	.63	345	6.0	.04	1,000	.03	349	6.3	.20	5,000	.55	380	6.3	.04	20,000	.02	381	6.3	.20	20,000	.40	344	10.0	.014	25,000	.002	367	10.0	.04	10,000	.08	330	14.0	.08	1,500	.50	382	14.0	.08	15,000	.30	370	18.0	.04	10,000	.15	*327	28.0	.04	4,000	.34	**387	28.0	.04	7,000	.30	<ul style="list-style-type: none"> • Ultra-Miniatures 	13-17																	
LAMP NO.	VOLTS	AMPERES	HOURS	CANDLE POWER																																																																																																															
331	1.35	.06	5,000	.006																																																																																																															
338	2.7	.06	6,000	.04																																																																																																															
375	3.0	.015	20,000	.004																																																																																																															
521-9057	5.0	.03	10,000	.02																																																																																																															
521-9058	5.0	.03	10,000	.02																																																																																																															
7332	5.0	.06	30,000	.05																																																																																																															
*328	6.0	.20	1,000	.63																																																																																																															
345	6.0	.04	1,000	.03																																																																																																															
349	6.3	.20	5,000	.55																																																																																																															
380	6.3	.04	20,000	.02																																																																																																															
381	6.3	.20	20,000	.40																																																																																																															
344	10.0	.014	25,000	.002																																																																																																															
367	10.0	.04	10,000	.08																																																																																																															
330	14.0	.08	1,500	.50																																																																																																															
382	14.0	.08	15,000	.30																																																																																																															
370	18.0	.04	10,000	.15																																																																																																															
*327	28.0	.04	4,000	.34																																																																																																															
**387	28.0	.04	7,000	.30																																																																																																															
 <p>T-1 3/4 midget flanged base</p>		<ul style="list-style-type: none"> • Sub-Miniatures • Press-to-Test • Transistorized Indicators • Placard Lights • Panel & Snap - in Mounting Indicators 	18-24 50-51 51 52 53-54																																																																																																																
 <p>T-2 Datalamp plug-in cartridges</p>	Available from 6-120V	<ul style="list-style-type: none"> • Ultra-Miniatures 	13-17																																																																																																																
 <p>T-2 Telephone slide base</p>	<table border="1"> <thead> <tr> <th>LAMP NO.</th> <th>VOLTS</th> <th>AMPS</th> <th>HOURS</th> <th>LAMP NO.</th> <th>VOLTS</th> <th>AMPS</th> <th>HOURS</th> </tr> </thead> <tbody> <tr><td>6A</td><td>6</td><td>.12-.16</td><td>5,000+</td><td>24E</td><td>24</td><td>.032-.038</td><td>5,000+</td></tr> <tr><td>6B</td><td>6</td><td>.27-.31</td><td>5,000+</td><td>24X</td><td>24</td><td>.032-.038</td><td>5,000+</td></tr> <tr><td>6C</td><td>6</td><td>.035-.045</td><td>5,000+</td><td>30A</td><td>30</td><td>.06-.085</td><td>5,000+</td></tr> <tr><td>8A</td><td>8</td><td>.08-.10</td><td>5,000+</td><td>30B</td><td>30</td><td>.09-.11</td><td>5,000+</td></tr> <tr><td>10A</td><td>10</td><td>.10-.12</td><td>5,000+</td><td>35A</td><td>35</td><td>.035-.045</td><td>5,000+</td></tr> <tr><td>12A</td><td>12</td><td>.09-.11</td><td>5,000+</td><td>48A</td><td>48</td><td>.06-.085</td><td>5,000+</td></tr> <tr><td>12B</td><td>12</td><td>.032-.038</td><td>5,000+</td><td>48B</td><td>48</td><td>.09-.11</td><td>5,000+</td></tr> <tr><td>16A</td><td>16</td><td>.09-.11</td><td>5,000+</td><td>48C</td><td>48</td><td>.032-.038</td><td>5,000+</td></tr> <tr><td>18B</td><td>18</td><td>.09-.11</td><td>5,000+</td><td>48D</td><td>48</td><td>.017-.025</td><td>5,000+</td></tr> <tr><td>24A</td><td>24</td><td>.025-.035</td><td>5,000+</td><td>55B</td><td>55</td><td>.09-.11</td><td>5,000+</td></tr> <tr><td>24B</td><td>24</td><td>.035-.045</td><td>5,000+</td><td>55C</td><td>55</td><td>.045-.06</td><td>5,000+</td></tr> <tr><td>24C</td><td>24</td><td>.06-.085</td><td>5,000+</td><td>60A</td><td>60</td><td>.045-.055</td><td>5,000+</td></tr> <tr><td>24D</td><td>24</td><td>.09-.11</td><td>5,000+</td><td colspan="4">No higher voltages available.</td></tr> </tbody> </table>	LAMP NO.	VOLTS	AMPS	HOURS	LAMP NO.	VOLTS	AMPS	HOURS	6A	6	.12-.16	5,000+	24E	24	.032-.038	5,000+	6B	6	.27-.31	5,000+	24X	24	.032-.038	5,000+	6C	6	.035-.045	5,000+	30A	30	.06-.085	5,000+	8A	8	.08-.10	5,000+	30B	30	.09-.11	5,000+	10A	10	.10-.12	5,000+	35A	35	.035-.045	5,000+	12A	12	.09-.11	5,000+	48A	48	.06-.085	5,000+	12B	12	.032-.038	5,000+	48B	48	.09-.11	5,000+	16A	16	.09-.11	5,000+	48C	48	.032-.038	5,000+	18B	18	.09-.11	5,000+	48D	48	.017-.025	5,000+	24A	24	.025-.035	5,000+	55B	55	.09-.11	5,000+	24B	24	.035-.045	5,000+	55C	55	.045-.06	5,000+	24C	24	.06-.085	5,000+	60A	60	.045-.055	5,000+	24D	24	.09-.11	5,000+	No higher voltages available.				<ul style="list-style-type: none"> • Miniatures 	25-35
LAMP NO.	VOLTS	AMPS	HOURS	LAMP NO.	VOLTS	AMPS	HOURS																																																																																																												
6A	6	.12-.16	5,000+	24E	24	.032-.038	5,000+																																																																																																												
6B	6	.27-.31	5,000+	24X	24	.032-.038	5,000+																																																																																																												
6C	6	.035-.045	5,000+	30A	30	.06-.085	5,000+																																																																																																												
8A	8	.08-.10	5,000+	30B	30	.09-.11	5,000+																																																																																																												
10A	10	.10-.12	5,000+	35A	35	.035-.045	5,000+																																																																																																												
12A	12	.09-.11	5,000+	48A	48	.06-.085	5,000+																																																																																																												
12B	12	.032-.038	5,000+	48B	48	.09-.11	5,000+																																																																																																												
16A	16	.09-.11	5,000+	48C	48	.032-.038	5,000+																																																																																																												
18B	18	.09-.11	5,000+	48D	48	.017-.025	5,000+																																																																																																												
24A	24	.025-.035	5,000+	55B	55	.09-.11	5,000+																																																																																																												
24B	24	.035-.045	5,000+	55C	55	.045-.06	5,000+																																																																																																												
24C	24	.06-.085	5,000+	60A	60	.045-.055	5,000+																																																																																																												
24D	24	.09-.11	5,000+	No higher voltages available.																																																																																																															
 <p>T-2 Telephone slide base (PSB type)</p>	<table border="1"> <thead> <tr> <th>LAMP NO.</th> <th>VOLTS</th> <th>AVG. WATTS</th> <th>AVG. CURRENT (AMPS)</th> <th>HOURS</th> </tr> </thead> <tbody> <tr><td>6PSB</td><td>6</td><td>.8</td><td>.140</td><td>5000+</td></tr> <tr><td>12PSB</td><td>12</td><td>2.0</td><td>.170</td><td>5000+</td></tr> <tr><td>24PSB</td><td>24</td><td>1.7</td><td>.073</td><td>5000+</td></tr> <tr><td>28PSB</td><td>28</td><td>1.1</td><td>.040</td><td>5000+</td></tr> <tr><td>48PSB</td><td>48</td><td>2.5</td><td>.053</td><td>5000+</td></tr> <tr><td>60PSB</td><td>60</td><td>3.0</td><td>.050</td><td>5000+</td></tr> <tr><td>120PSB</td><td>120</td><td>3.0</td><td>.025</td><td>5000+</td></tr> </tbody> </table>	LAMP NO.	VOLTS	AVG. WATTS	AVG. CURRENT (AMPS)	HOURS	6PSB	6	.8	.140	5000+	12PSB	12	2.0	.170	5000+	24PSB	24	1.7	.073	5000+	28PSB	28	1.1	.040	5000+	48PSB	48	2.5	.053	5000+	60PSB	60	3.0	.050	5000+	120PSB	120	3.0	.025	5000+	<ul style="list-style-type: none"> • Miniatures 	25-35																																																																								
LAMP NO.	VOLTS	AVG. WATTS	AVG. CURRENT (AMPS)	HOURS																																																																																																															
6PSB	6	.8	.140	5000+																																																																																																															
12PSB	12	2.0	.170	5000+																																																																																																															
24PSB	24	1.7	.073	5000+																																																																																																															
28PSB	28	1.1	.040	5000+																																																																																																															
48PSB	48	2.5	.053	5000+																																																																																																															
60PSB	60	3.0	.050	5000+																																																																																																															
120PSB	120	3.0	.025	5000+																																																																																																															

INCANDESCENT (continued)

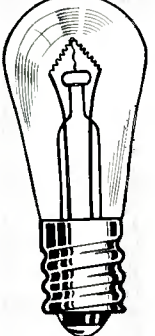
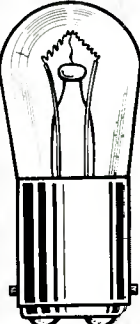
LAMP	MANUFACTURER'S RATINGS	ACCOMMODATED BY INDICATOR LIGHTS DESCRIBED IN SECTION(S):	SEE PAGE NOS.																																																																																																												
T-3  Miniature bayonet base	<table border="1" style="margin: auto;"> <thead> <tr> <th>LAMP NO.</th> <th>VOLTS</th> <th>AVG. WATTS</th> <th>AVG. CURRENT (AMPS)</th> <th>HOURS</th> </tr> </thead> <tbody> <tr><td>6MB</td><td>6</td><td>.8</td><td>.140</td><td>5000+</td></tr> <tr><td>12MB</td><td>12</td><td>2.0</td><td>.170</td><td>5000+</td></tr> <tr><td>24MB</td><td>24</td><td>1.7</td><td>.073</td><td>5000+</td></tr> <tr><td>28MB</td><td>28</td><td>1.1</td><td>.040</td><td>5000+</td></tr> <tr><td>48MB</td><td>48</td><td>2.5</td><td>.053</td><td>5000+</td></tr> <tr><td>60MB</td><td>60</td><td>3.0</td><td>.050</td><td>5000+</td></tr> <tr><td>120MB</td><td>120</td><td>3.0</td><td>.025</td><td>5000+</td></tr> </tbody> </table>	LAMP NO.	VOLTS	AVG. WATTS	AVG. CURRENT (AMPS)	HOURS	6MB	6	.8	.140	5000+	12MB	12	2.0	.170	5000+	24MB	24	1.7	.073	5000+	28MB	28	1.1	.040	5000+	48MB	48	2.5	.053	5000+	60MB	60	3.0	.050	5000+	120MB	120	3.0	.025	5000+	<ul style="list-style-type: none"> ● Miniatures ● Open Type Indicators 	25-35 42-43																																																																				
LAMP NO.	VOLTS	AVG. WATTS	AVG. CURRENT (AMPS)	HOURS																																																																																																											
6MB	6	.8	.140	5000+																																																																																																											
12MB	12	2.0	.170	5000+																																																																																																											
24MB	24	1.7	.073	5000+																																																																																																											
28MB	28	1.1	.040	5000+																																																																																																											
48MB	48	2.5	.053	5000+																																																																																																											
60MB	60	3.0	.050	5000+																																																																																																											
120MB	120	3.0	.025	5000+																																																																																																											
T-3¹/₄  Miniature bayonet base	<table border="1" style="margin: auto;"> <thead> <tr> <th>LAMP NO.</th> <th>VOLTS</th> <th>AMPS</th> <th>WATTS</th> <th>C.P.</th> <th>HOURS</th> </tr> </thead> <tbody> <tr><td>49</td><td>2.0</td><td>0.06</td><td>0.12</td><td>0.04</td><td>1,000</td></tr> <tr><td>45</td><td>3.2</td><td>0.35</td><td>1.12</td><td>0.50</td><td>3,000</td></tr> <tr><td>47</td><td>6.3</td><td>0.15</td><td>0.95</td><td>0.52</td><td>3,000</td></tr> <tr><td>1847</td><td>6.3</td><td>0.15</td><td>0.95</td><td>0.38</td><td>3,000</td></tr> <tr><td>44</td><td>6.3</td><td>0.25</td><td>1.6</td><td>0.90</td><td>3,000</td></tr> <tr><td>1866</td><td>6.3</td><td>0.25</td><td>1.6</td><td>0.65</td><td>20,000</td></tr> <tr><td>755</td><td>6.3</td><td>0.15</td><td>0.95</td><td>0.33</td><td>20,000</td></tr> <tr><td>1891*</td><td>14.0</td><td>0.24</td><td>3.4</td><td>2.0</td><td>500</td></tr> <tr><td>1815*</td><td>14.0</td><td>0.20</td><td>2.8</td><td>1.4</td><td>3,000</td></tr> <tr><td>756</td><td>14.0</td><td>0.08</td><td>1.1</td><td>0.31</td><td>15,000</td></tr> <tr><td>1819</td><td>28.0</td><td>0.04</td><td>1.1</td><td>0.34</td><td>1,000</td></tr> <tr><td>1829</td><td>28.0</td><td>0.07</td><td>1.9</td><td>1.0</td><td>1,000</td></tr> <tr><td>1820*</td><td>28.0</td><td>0.10</td><td>2.8</td><td>1.6</td><td>1,000</td></tr> <tr><td>313*</td><td>28.0</td><td>0.17</td><td>4.7</td><td>3.5</td><td>500</td></tr> <tr><td>757*</td><td>28.0</td><td>0.08</td><td>2.3</td><td>0.62</td><td>7,500</td></tr> <tr><td>1828</td><td>37.5</td><td>0.05</td><td>1.9</td><td>0.65</td><td>20,000</td></tr> <tr><td>1835*</td><td>55.0</td><td>0.05</td><td>2.8</td><td>1.1</td><td>20,000</td></tr> </tbody> </table> <p style="font-size: small; margin-top: 5px;">*These lamps, of 2 watts or more, should be used only in indicator lights designed for high temperature operation.</p>	LAMP NO.	VOLTS	AMPS	WATTS	C.P.	HOURS	49	2.0	0.06	0.12	0.04	1,000	45	3.2	0.35	1.12	0.50	3,000	47	6.3	0.15	0.95	0.52	3,000	1847	6.3	0.15	0.95	0.38	3,000	44	6.3	0.25	1.6	0.90	3,000	1866	6.3	0.25	1.6	0.65	20,000	755	6.3	0.15	0.95	0.33	20,000	1891*	14.0	0.24	3.4	2.0	500	1815*	14.0	0.20	2.8	1.4	3,000	756	14.0	0.08	1.1	0.31	15,000	1819	28.0	0.04	1.1	0.34	1,000	1829	28.0	0.07	1.9	1.0	1,000	1820*	28.0	0.10	2.8	1.6	1,000	313*	28.0	0.17	4.7	3.5	500	757*	28.0	0.08	2.3	0.62	7,500	1828	37.5	0.05	1.9	0.65	20,000	1835*	55.0	0.05	2.8	1.1	20,000	<ul style="list-style-type: none"> ● Miniatures ● Large ● Open Type Indicators ● Socket Assemblies ● Oil-Tights ● Press-to-Test 	25-35 36-41 42-43 45 46-49 50-51
LAMP NO.	VOLTS	AMPS	WATTS	C.P.	HOURS																																																																																																										
49	2.0	0.06	0.12	0.04	1,000																																																																																																										
45	3.2	0.35	1.12	0.50	3,000																																																																																																										
47	6.3	0.15	0.95	0.52	3,000																																																																																																										
1847	6.3	0.15	0.95	0.38	3,000																																																																																																										
44	6.3	0.25	1.6	0.90	3,000																																																																																																										
1866	6.3	0.25	1.6	0.65	20,000																																																																																																										
755	6.3	0.15	0.95	0.33	20,000																																																																																																										
1891*	14.0	0.24	3.4	2.0	500																																																																																																										
1815*	14.0	0.20	2.8	1.4	3,000																																																																																																										
756	14.0	0.08	1.1	0.31	15,000																																																																																																										
1819	28.0	0.04	1.1	0.34	1,000																																																																																																										
1829	28.0	0.07	1.9	1.0	1,000																																																																																																										
1820*	28.0	0.10	2.8	1.6	1,000																																																																																																										
313*	28.0	0.17	4.7	3.5	500																																																																																																										
757*	28.0	0.08	2.3	0.62	7,500																																																																																																										
1828	37.5	0.05	1.9	0.65	20,000																																																																																																										
1835*	55.0	0.05	2.8	1.1	20,000																																																																																																										
G-3¹/₂  Miniature bayonet base	<table border="1" style="margin: auto;"> <thead> <tr> <th>LAMP NO.</th> <th>VOLTS</th> <th>AMPS</th> <th>C.P.</th> <th>HOURS</th> </tr> </thead> <tbody> <tr><td>51</td><td>7.5</td><td>.22</td><td>1.0</td><td>1000</td></tr> <tr><td>53</td><td>14.4</td><td>.12</td><td>1.0</td><td>1000</td></tr> <tr><td>1445</td><td>18.0</td><td>.15</td><td>1.5</td><td>250</td></tr> </tbody> </table>	LAMP NO.	VOLTS	AMPS	C.P.	HOURS	51	7.5	.22	1.0	1000	53	14.4	.12	1.0	1000	1445	18.0	.15	1.5	250	<ul style="list-style-type: none"> ● Open Type Indicators 	42-43																																																																																								
LAMP NO.	VOLTS	AMPS	C.P.	HOURS																																																																																																											
51	7.5	.22	1.0	1000																																																																																																											
53	14.4	.12	1.0	1000																																																																																																											
1445	18.0	.15	1.5	250																																																																																																											
S-6  Candelabra screw base	<table border="1" style="margin: auto;"> <thead> <tr> <th>LAMP NO.</th> <th>WATTS</th> <th>VOLTS</th> <th>HOURS</th> </tr> </thead> <tbody> <tr><td>6S6-6V</td><td>6</td><td>6</td><td>1500</td></tr> <tr><td>6S6-12V</td><td>6</td><td>12</td><td>1500</td></tr> <tr><td>6S6-24V</td><td>6</td><td>24</td><td>1500</td></tr> <tr><td>6S6-30V</td><td>6</td><td>30</td><td>1500</td></tr> <tr><td>6S6-48V</td><td>6</td><td>48</td><td>1500</td></tr> <tr><td>6S6-75V</td><td>6</td><td>75</td><td>1500</td></tr> <tr><td>6S6-125V</td><td>6</td><td>125</td><td>1500</td></tr> <tr><td>6S6-135V</td><td>6</td><td>135</td><td>1500</td></tr> <tr><td>6S6-145V</td><td>6</td><td>145</td><td>1500</td></tr> <tr><td>10S6-230V</td><td>10</td><td>230</td><td>1500</td></tr> <tr><td>10S6-250V</td><td>10</td><td>250</td><td>1500</td></tr> </tbody> </table>	LAMP NO.	WATTS	VOLTS	HOURS	6S6-6V	6	6	1500	6S6-12V	6	12	1500	6S6-24V	6	24	1500	6S6-30V	6	30	1500	6S6-48V	6	48	1500	6S6-75V	6	75	1500	6S6-125V	6	125	1500	6S6-135V	6	135	1500	6S6-145V	6	145	1500	10S6-230V	10	230	1500	10S6-250V	10	250	1500	<ul style="list-style-type: none"> ● Large ● Open Type Indicators ● Oil-Tights 	36-41 42-43 46-49																																																												
LAMP NO.	WATTS	VOLTS	HOURS																																																																																																												
6S6-6V	6	6	1500																																																																																																												
6S6-12V	6	12	1500																																																																																																												
6S6-24V	6	24	1500																																																																																																												
6S6-30V	6	30	1500																																																																																																												
6S6-48V	6	48	1500																																																																																																												
6S6-75V	6	75	1500																																																																																																												
6S6-125V	6	125	1500																																																																																																												
6S6-135V	6	135	1500																																																																																																												
6S6-145V	6	145	1500																																																																																																												
10S6-230V	10	230	1500																																																																																																												
10S6-250V	10	250	1500																																																																																																												
S-6  Double contact bayonet base	<table border="1" style="margin: auto;"> <thead> <tr> <th>LAMP NO.</th> <th>WATTS</th> <th>VOLTS</th> <th>HOURS</th> </tr> </thead> <tbody> <tr><td>6S6DC-6V</td><td>6</td><td>6</td><td>1500</td></tr> <tr><td>6S6DC-12V</td><td>6</td><td>12</td><td>1500</td></tr> <tr><td>6S6DC-24V</td><td>6</td><td>24</td><td>1500</td></tr> <tr><td>6S6DC-30V</td><td>6</td><td>30</td><td>1500</td></tr> <tr><td>6S6DC-48V</td><td>6</td><td>48</td><td>1500</td></tr> <tr><td>6S6DC-75V</td><td>6</td><td>75</td><td>1500</td></tr> <tr><td>6S6DC-125V</td><td>6</td><td>125</td><td>1500</td></tr> <tr><td>6S6DC-135V</td><td>6</td><td>135</td><td>1500</td></tr> <tr><td>6S6DC-145V</td><td>6</td><td>145</td><td>1500</td></tr> <tr><td>10S6DC-230V</td><td>10</td><td>230</td><td>1500</td></tr> <tr><td>10S6DC-250V</td><td>10</td><td>250</td><td>1500</td></tr> </tbody> </table>	LAMP NO.	WATTS	VOLTS	HOURS	6S6DC-6V	6	6	1500	6S6DC-12V	6	12	1500	6S6DC-24V	6	24	1500	6S6DC-30V	6	30	1500	6S6DC-48V	6	48	1500	6S6DC-75V	6	75	1500	6S6DC-125V	6	125	1500	6S6DC-135V	6	135	1500	6S6DC-145V	6	145	1500	10S6DC-230V	10	230	1500	10S6DC-250V	10	250	1500	<ul style="list-style-type: none"> ● Large ● Open Type Indicators ● Oil-Tights 	36-41 42-43 46-49																																																												
LAMP NO.	WATTS	VOLTS	HOURS																																																																																																												
6S6DC-6V	6	6	1500																																																																																																												
6S6DC-12V	6	12	1500																																																																																																												
6S6DC-24V	6	24	1500																																																																																																												
6S6DC-30V	6	30	1500																																																																																																												
6S6DC-48V	6	48	1500																																																																																																												
6S6DC-75V	6	75	1500																																																																																																												
6S6DC-125V	6	125	1500																																																																																																												
6S6DC-135V	6	135	1500																																																																																																												
6S6DC-145V	6	145	1500																																																																																																												
10S6DC-230V	10	230	1500																																																																																																												
10S6DC-250V	10	250	1500																																																																																																												

INCANDESCENT (continued)

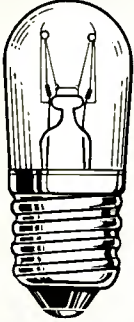
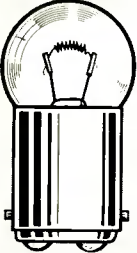
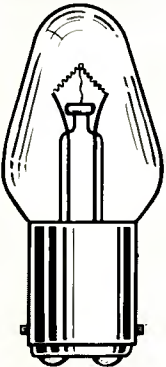
LAMP	MANUFACTURER'S RATINGS	ACCOMMODATED BY INDICATOR LIGHTS DESCRIBED IN SECTION(S):	SEE PAGE NOS.																														
<p style="text-align: center;">S-6</p>  <p style="text-align: center;">Intermediate screw base</p>	<table border="1" style="margin: auto;"> <thead> <tr> <th>LAMP NO.</th> <th>VOLTS</th> </tr> </thead> <tbody> <tr> <td>6S6/7</td> <td>125</td> </tr> <tr> <td>10S6/13</td> <td>230</td> </tr> <tr> <td>10S6/13</td> <td>250</td> </tr> </tbody> </table>	LAMP NO.	VOLTS	6S6/7	125	10S6/13	230	10S6/13	250	<ul style="list-style-type: none"> • Oil-Tights 	46-49																						
LAMP NO.	VOLTS																																
6S6/7	125																																
10S6/13	230																																
10S6/13	250																																
<p style="text-align: center;">G-6</p>  <p style="text-align: center;">Double contact bayonet base</p>	<table border="1" style="margin: auto;"> <thead> <tr> <th>LAMP NO.</th> <th>VOLTS</th> <th>AMPS</th> <th>C.P.</th> <th>HOURS</th> </tr> </thead> <tbody> <tr> <td>82</td> <td>6.5</td> <td>1.0</td> <td>6.0</td> <td>500</td> </tr> <tr> <td>68</td> <td>13.5</td> <td>.59</td> <td>4.0</td> <td>5000+</td> </tr> <tr> <td>90</td> <td>13.0</td> <td>.58</td> <td>6.0</td> <td>750</td> </tr> <tr> <td>304</td> <td>28.0</td> <td>.30</td> <td>6.0</td> <td>500</td> </tr> <tr> <td>1224</td> <td>32.0</td> <td>.16</td> <td>3.0</td> <td>200</td> </tr> </tbody> </table>	LAMP NO.	VOLTS	AMPS	C.P.	HOURS	82	6.5	1.0	6.0	500	68	13.5	.59	4.0	5000+	90	13.0	.58	6.0	750	304	28.0	.30	6.0	500	1224	32.0	.16	3.0	200	<ul style="list-style-type: none"> • Large • Socket Assemblies 	36-41 45
LAMP NO.	VOLTS	AMPS	C.P.	HOURS																													
82	6.5	1.0	6.0	500																													
68	13.5	.59	4.0	5000+																													
90	13.0	.58	6.0	750																													
304	28.0	.30	6.0	500																													
1224	32.0	.16	3.0	200																													
<p style="text-align: center;">C-7</p>  <p style="text-align: center;">Double contact bayonet base</p>	<table border="1" style="margin: auto;"> <thead> <tr> <th>LAMP NO.</th> <th>VOLTS</th> <th>WATTS</th> <th>HOURS</th> </tr> </thead> <tbody> <tr> <td>10C7/DC</td> <td>120</td> <td>10</td> <td>6000</td> </tr> <tr> <td>10C7/5DC</td> <td>120</td> <td>10</td> <td>8000</td> </tr> </tbody> </table>	LAMP NO.	VOLTS	WATTS	HOURS	10C7/DC	120	10	6000	10C7/5DC	120	10	8000	<ul style="list-style-type: none"> • Open Type Indicators • Socket Assemblies • Oil-Tights 	42-43 45 46-49																		
LAMP NO.	VOLTS	WATTS	HOURS																														
10C7/DC	120	10	6000																														
10C7/5DC	120	10	8000																														

NEON

Neon Lamps make extremely versatile indicators and are useful where a minimum of 105 volts is available.





Light output is low compared to incandescents, and of a limited color range, making blue and green lenses unsuitable for use. Reliability is extremely high, with early failure practically unknown. The lamps are very rugged and generally unaffected by vibration, shock and voltage variations.

The light output varies in direct proportion to the current through the lamp. All neons must be ballasted to prevent instantaneous burnout. This is usually performed by a resistor in series with the lamp. The value of the resistor combined with the applied voltage determines the current through the lamp and thus its light output.

This necessary current-limiting resistor is available "built-in" as an integral part of Dialco assemblies (a patented feature, U.S. Pat. No. 2,421,321).

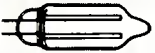
LAMP	BUILT-IN RESISTOR VALUES	ACCOMMODATED BY INDICATOR LIGHTS DESCRIBED IN SECTION(S):	PAGE NOS.																						
<p style="text-align: center;">T-2</p>  <p style="text-align: center;">Datalamp plug-in cartridges</p>	<table border="1" style="margin: auto;"> <thead> <tr> <th rowspan="2">NEON LAMP</th> <th rowspan="2">VOLTS APPLIED TO TERMINALS</th> <th colspan="2">BRIGHT LIGHT</th> <th colspan="2">LONG LIFE</th> </tr> <tr> <th>RESISTOR AND APPROX. LIFE▲</th> <th>RESISTOR AND APPROX. LIFE▲</th> <th>RESISTOR AND APPROX. LIFE▲</th> <th>RESISTOR AND APPROX. LIFE▲</th> </tr> </thead> <tbody> <tr> <td>A1B Standard Brightness</td> <td>105-125 AC or DC</td> <td>56K 3,000 hrs.</td> <td>100K 15,000 hrs.</td> <td>100K 15,000 hrs.</td> <td>100K 15,000 hrs.</td> </tr> <tr> <td>A1C High Brightness</td> <td>110-125 AC only</td> <td>22K 5,000 hrs.</td> <td>33K 25,000 hrs.</td> <td>33K 25,000 hrs.</td> <td>33K 25,000 hrs.</td> </tr> </tbody> </table>	NEON LAMP	VOLTS APPLIED TO TERMINALS	BRIGHT LIGHT		LONG LIFE		RESISTOR AND APPROX. LIFE▲	RESISTOR AND APPROX. LIFE▲	RESISTOR AND APPROX. LIFE▲	RESISTOR AND APPROX. LIFE▲	A1B Standard Brightness	105-125 AC or DC	56K 3,000 hrs.	100K 15,000 hrs.	100K 15,000 hrs.	100K 15,000 hrs.	A1C High Brightness	110-125 AC only	22K 5,000 hrs.	33K 25,000 hrs.	33K 25,000 hrs.	33K 25,000 hrs.	<ul style="list-style-type: none"> • Ultra-Miniatures 	13-17
NEON LAMP	VOLTS APPLIED TO TERMINALS			BRIGHT LIGHT		LONG LIFE																			
		RESISTOR AND APPROX. LIFE▲	RESISTOR AND APPROX. LIFE▲	RESISTOR AND APPROX. LIFE▲	RESISTOR AND APPROX. LIFE▲																				
A1B Standard Brightness	105-125 AC or DC	56K 3,000 hrs.	100K 15,000 hrs.	100K 15,000 hrs.	100K 15,000 hrs.																				
A1C High Brightness	110-125 AC only	22K 5,000 hrs.	33K 25,000 hrs.	33K 25,000 hrs.	33K 25,000 hrs.																				

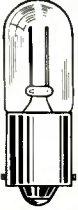
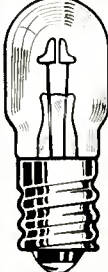
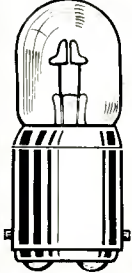



NEON (continued)

LAMP	BUILT-IN RESISTOR VALUES	ACCOMMODATED BY INDICATOR LIGHTS DESCRIBED IN SECTION(S):	SEE PAGE NOS.																
T-2 	<table border="1" style="width: 100%; border-collapse: collapse;"> <thead> <tr> <th rowspan="2">NEON LAMP</th> <th rowspan="2">VOLTS APPLIED TO TERMINALS</th> <th>BRIGHT LIGHT</th> <th>LONG LIFE</th> </tr> <tr> <th>RESISTOR AND APPROX. LIFE ▲</th> <th>RESISTOR AND APPROX. LIFE ▲</th> </tr> </thead> <tbody> <tr> <td>A9A</td> <td>105-125 AC or DC</td> <td>56K 3,000 hrs.</td> <td>100K 15,000 hrs.</td> </tr> <tr> <td>C2A</td> <td>110-125 AC only</td> <td>22K 5,000 hrs.</td> <td>33K 25,000 hrs.</td> </tr> </tbody> </table>	NEON LAMP	VOLTS APPLIED TO TERMINALS	BRIGHT LIGHT	LONG LIFE	RESISTOR AND APPROX. LIFE ▲	RESISTOR AND APPROX. LIFE ▲	A9A	105-125 AC or DC	56K 3,000 hrs.	100K 15,000 hrs.	C2A	110-125 AC only	22K 5,000 hrs.	33K 25,000 hrs.	<ul style="list-style-type: none"> ● Ultra-Miniatures ● Panel & Snap-in Mounting Indicators 	13-17 53-54		
NEON LAMP	VOLTS APPLIED TO TERMINALS			BRIGHT LIGHT	LONG LIFE														
		RESISTOR AND APPROX. LIFE ▲	RESISTOR AND APPROX. LIFE ▲																
A9A	105-125 AC or DC	56K 3,000 hrs.	100K 15,000 hrs.																
C2A	110-125 AC only	22K 5,000 hrs.	33K 25,000 hrs.																
T-2  Midget flanged base	<table border="1" style="width: 100%; border-collapse: collapse;"> <thead> <tr> <th colspan="2">STANDARD BRIGHTNESS</th> <th colspan="2">HIGH BRIGHTNESS</th> </tr> </thead> <tbody> <tr> <td>C7A (NE-2D)</td> <td>105-125V AC-DC</td> <td>C9A (NE-2J)</td> <td>110-125V AC ONLY</td> </tr> <tr> <td>BRIGHT LIGHT</td> <td>■ 62K</td> <td>BRIGHT LIGHT</td> <td>■ 22K</td> </tr> <tr> <td>LONG LIFE</td> <td>100K</td> <td>LONG LIFE</td> <td>33K</td> </tr> </tbody> </table> <p style="text-align: center; font-size: small;">■ Standard value of patented built-in resistor. (Other values optional.)</p>	STANDARD BRIGHTNESS		HIGH BRIGHTNESS		C7A (NE-2D)	105-125V AC-DC	C9A (NE-2J)	110-125V AC ONLY	BRIGHT LIGHT	■ 62K	BRIGHT LIGHT	■ 22K	LONG LIFE	100K	LONG LIFE	33K	<ul style="list-style-type: none"> ● Sub-Miniatures 	18-24
STANDARD BRIGHTNESS		HIGH BRIGHTNESS																	
C7A (NE-2D)	105-125V AC-DC	C9A (NE-2J)	110-125V AC ONLY																
BRIGHT LIGHT	■ 62K	BRIGHT LIGHT	■ 22K																
LONG LIFE	100K	LONG LIFE	33K																
T-3¼  Miniature bayonet base	<table border="1" style="width: 100%; border-collapse: collapse;"> <thead> <tr> <th colspan="2">B2A (NE-51H) HIGH BRIGHTNESS</th> <th colspan="2">B1A (NE-51) STANDARD BRIGHTNESS</th> </tr> </thead> <tbody> <tr> <td>110-125 AC</td> <td>210-250 AC-DC</td> <td colspan="2">105-125 AC-DC</td> </tr> <tr> <td>BRIGHT LIGHT</td> <td>■ 22K ■ 68K</td> <td>BRIGHT LIGHT</td> <td>■ 56K</td> </tr> <tr> <td>LONG LIFE</td> <td>33K 100K</td> <td>LONG LIFE</td> <td>100K</td> </tr> </tbody> </table> <p style="text-align: center; font-size: small;">■ Standard values of patented built-in resistors; other values optional. Note: The B2A NE-51H lamp is not recommended for use on DC circuits under 100V.</p>	B2A (NE-51H) HIGH BRIGHTNESS		B1A (NE-51) STANDARD BRIGHTNESS		110-125 AC	210-250 AC-DC	105-125 AC-DC		BRIGHT LIGHT	■ 22K ■ 68K	BRIGHT LIGHT	■ 56K	LONG LIFE	33K 100K	LONG LIFE	100K	<ul style="list-style-type: none"> ● Miniatures ● Large ● Oil-Tights 	25-35 36-41 46-49
B2A (NE-51H) HIGH BRIGHTNESS		B1A (NE-51) STANDARD BRIGHTNESS																	
110-125 AC	210-250 AC-DC	105-125 AC-DC																	
BRIGHT LIGHT	■ 22K ■ 68K	BRIGHT LIGHT	■ 56K																
LONG LIFE	33K 100K	LONG LIFE	100K																
T-4½  Candelabra screw base	<table border="1" style="width: 100%; border-collapse: collapse;"> <tbody> <tr> <td>105-125V</td> <td>—</td> <td>Lamp base has appropriate resistor built-in.</td> </tr> <tr> <td>210-250V</td> <td>—</td> <td>Lamp base has appropriate resistor built-in.</td> </tr> </tbody> </table>	105-125V	—	Lamp base has appropriate resistor built-in.	210-250V	—	Lamp base has appropriate resistor built-in.	<ul style="list-style-type: none"> ● Large ● Oil-Tights 	36-41 46-49										
105-125V	—	Lamp base has appropriate resistor built-in.																	
210-250V	—	Lamp base has appropriate resistor built-in.																	
T-4½  Double contact bayonet base	<p style="text-align: center;">B9A - (NE-48); 7AA (NE-16); B5A (NE-17)</p> <table border="1" style="width: 100%; border-collapse: collapse;"> <thead> <tr> <th>105-125 VOLTS</th> <th>RECOMMENDED RESISTOR</th> <th>210-250 VOLTS</th> <th>RECOMMENDED RESISTOR</th> </tr> </thead> <tbody> <tr> <td>BEST LIGHT</td> <td>■ 16.4K</td> <td>BEST LIGHT</td> <td>44K</td> </tr> <tr> <td>LONG LIFE</td> <td>30K</td> <td>LONG LIFE</td> <td>94K</td> </tr> </tbody> </table> <p style="text-align: center; font-size: small;">■ Standard value of patented built-in resistor. (Other values optional.)</p>	105-125 VOLTS	RECOMMENDED RESISTOR	210-250 VOLTS	RECOMMENDED RESISTOR	BEST LIGHT	■ 16.4K	BEST LIGHT	44K	LONG LIFE	30K	LONG LIFE	94K	<ul style="list-style-type: none"> ● Oil-Tights 	46-49				
105-125 VOLTS	RECOMMENDED RESISTOR	210-250 VOLTS	RECOMMENDED RESISTOR																
BEST LIGHT	■ 16.4K	BEST LIGHT	44K																
LONG LIFE	30K	LONG LIFE	94K																
S-7  Double contact bayonet base	<p style="text-align: center;">R1A - (NE-79)</p> <table border="1" style="width: 100%; border-collapse: collapse;"> <thead> <tr> <th>105-125 VOLTS</th> <th>RECOMMENDED RESISTOR</th> <th>210-250 VOLTS</th> <th>RECOMMENDED RESISTOR</th> </tr> </thead> <tbody> <tr> <td>BRIGHT LIGHT</td> <td>■ 3K</td> <td>BRIGHT LIGHT</td> <td>*</td> </tr> <tr> <td>LONG LIFE</td> <td>6K</td> <td>LONG LIFE</td> <td>60K</td> </tr> </tbody> </table> <p style="text-align: center; font-size: small;">■ Standard value of patented built-in resistor; other values optional. * 9,400 ohms is recommended for bright light and intermittent service.</p>	105-125 VOLTS	RECOMMENDED RESISTOR	210-250 VOLTS	RECOMMENDED RESISTOR	BRIGHT LIGHT	■ 3K	BRIGHT LIGHT	*	LONG LIFE	6K	LONG LIFE	60K	<ul style="list-style-type: none"> ● Oil-Tights 	46-49				
105-125 VOLTS	RECOMMENDED RESISTOR	210-250 VOLTS	RECOMMENDED RESISTOR																
BRIGHT LIGHT	■ 3K	BRIGHT LIGHT	*																
LONG LIFE	6K	LONG LIFE	60K																

▲ Ratings of lamps are taken from published catalogs of leading lamp manufacturers.

SOLID STATE LED LAMPS

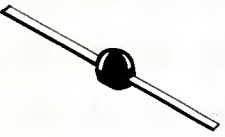
- Additional solid state LED lamps will be added to our line. To be sure of obtaining current information, request LED Catalog SG731

LAMP	RATINGS AND DESCRIPTION																																																																													
 <p>* 521-9167 red diffused 521-9168 clear diffused</p>  <p>** 521-9165 red diffused 521-9166 clear diffused 521-9190 clear non-diffused</p>  <p>521-9180 red diffused</p>	<p>Maximum Ratings</p> <table border="1"> <tr> <td>Forward DC Current</td> <td>50 mA</td> </tr> <tr> <td>Reverse Voltage</td> <td>3 Volts</td> </tr> <tr> <td>Power Dissipation - Derate 1.3 mW/°C above 25°C</td> <td>100 mW</td> </tr> <tr> <td>Storage Temperature</td> <td>-40°C to 100°C</td> </tr> <tr> <td>Operating Temperature</td> <td>-40°C to 100°C</td> </tr> <tr> <td>Relative Humidity @ 65°C</td> <td>98%</td> </tr> <tr> <td>Solder Temperature for 5 seconds</td> <td>250°C @ 0.1" from Seating Plane</td> </tr> </table> <p>* May be panel mounted as an indicator. Use No. 515-0003 Press-fit Mount in panels .030" to .250" thick.</p> <p>** May be panel mounted as an Snap-in Mounts: No. 515-0001 - for .040" panel thickness No. 515-0002 - for .062" to .125" panel thickness</p> <p>Radiant Characteristics @ I_F = 20 mA (25°C)</p> <table border="1"> <thead> <tr> <th rowspan="2">Parameters</th> <th>521-9167 & 521-9168</th> <th rowspan="2">Units</th> </tr> <tr> <th>Typical</th> </tr> </thead> <tbody> <tr> <td>Luminous Intensity</td> <td>1.0†</td> <td>mcd</td> </tr> <tr> <td>Luminous Flux</td> <td>1.35</td> <td>mlumen</td> </tr> <tr> <td>Wavelength @ Peak</td> <td>650</td> <td>nM</td> </tr> <tr> <td>Spectral Line Width</td> <td>25</td> <td>nM</td> </tr> <tr> <td>Rise and Fall Time</td> <td>10</td> <td>ns</td> </tr> <tr> <td>Angle of Half Intensity</td> <td>35</td> <td>degrees</td> </tr> <tr> <td>Angle of 0.1 Intensity</td> <td>85</td> <td>degrees</td> </tr> </tbody> </table> <p>† 521-9165; 521-9166; 521-9180 & 521-9190: 2.0</p> <p>Typical Resistor Values</p> <table border="1"> <thead> <tr> <th rowspan="2">DC Voltage</th> <th>Current @ 10 mA</th> <th>Current @ 20 mA</th> </tr> <tr> <th>R_L</th> <th>R_L</th> </tr> </thead> <tbody> <tr> <td>3.6</td> <td>200 Ω</td> <td>100 Ω</td> </tr> <tr> <td>5</td> <td>330 Ω</td> <td>180 Ω</td> </tr> <tr> <td>6</td> <td>430 Ω</td> <td>220 Ω</td> </tr> <tr> <td>10</td> <td>820 Ω</td> <td>390 Ω</td> </tr> <tr> <td>14</td> <td>1200Ω</td> <td>620 Ω</td> </tr> <tr> <td>28</td> <td>2700Ω</td> <td>1300Ω</td> </tr> </tbody> </table> <p>Electrical Characteristics (25°C)</p> <table border="1"> <thead> <tr> <th>Symbol</th> <th>Parameters</th> <th>Minimum</th> <th>Typical</th> <th>Maximum</th> </tr> </thead> <tbody> <tr> <td>V_F</td> <td>Forward Voltage @ 50 mA</td> <td>-</td> <td>1.8V</td> <td>2.3V</td> </tr> <tr> <td>BV_R</td> <td>Reverse Breakdown Voltage @ 10 μA</td> <td>3.0V</td> <td>8.0V</td> <td>-</td> </tr> </tbody> </table>	Forward DC Current	50 mA	Reverse Voltage	3 Volts	Power Dissipation - Derate 1.3 mW/°C above 25°C	100 mW	Storage Temperature	-40°C to 100°C	Operating Temperature	-40°C to 100°C	Relative Humidity @ 65°C	98%	Solder Temperature for 5 seconds	250°C @ 0.1" from Seating Plane	Parameters	521-9167 & 521-9168	Units	Typical	Luminous Intensity	1.0†	mcd	Luminous Flux	1.35	mlumen	Wavelength @ Peak	650	nM	Spectral Line Width	25	nM	Rise and Fall Time	10	ns	Angle of Half Intensity	35	degrees	Angle of 0.1 Intensity	85	degrees	DC Voltage	Current @ 10 mA	Current @ 20 mA	R _L	R _L	3.6	200 Ω	100 Ω	5	330 Ω	180 Ω	6	430 Ω	220 Ω	10	820 Ω	390 Ω	14	1200Ω	620 Ω	28	2700Ω	1300Ω	Symbol	Parameters	Minimum	Typical	Maximum	V _F	Forward Voltage @ 50 mA	-	1.8V	2.3V	BV _R	Reverse Breakdown Voltage @ 10 μA	3.0V	8.0V	-
Forward DC Current	50 mA																																																																													
Reverse Voltage	3 Volts																																																																													
Power Dissipation - Derate 1.3 mW/°C above 25°C	100 mW																																																																													
Storage Temperature	-40°C to 100°C																																																																													
Operating Temperature	-40°C to 100°C																																																																													
Relative Humidity @ 65°C	98%																																																																													
Solder Temperature for 5 seconds	250°C @ 0.1" from Seating Plane																																																																													
Parameters	521-9167 & 521-9168	Units																																																																												
	Typical																																																																													
Luminous Intensity	1.0†	mcd																																																																												
Luminous Flux	1.35	mlumen																																																																												
Wavelength @ Peak	650	nM																																																																												
Spectral Line Width	25	nM																																																																												
Rise and Fall Time	10	ns																																																																												
Angle of Half Intensity	35	degrees																																																																												
Angle of 0.1 Intensity	85	degrees																																																																												
DC Voltage	Current @ 10 mA	Current @ 20 mA																																																																												
	R _L	R _L																																																																												
3.6	200 Ω	100 Ω																																																																												
5	330 Ω	180 Ω																																																																												
6	430 Ω	220 Ω																																																																												
10	820 Ω	390 Ω																																																																												
14	1200Ω	620 Ω																																																																												
28	2700Ω	1300Ω																																																																												
Symbol	Parameters	Minimum	Typical	Maximum																																																																										
V _F	Forward Voltage @ 50 mA	-	1.8V	2.3V																																																																										
BV _R	Reverse Breakdown Voltage @ 10 μA	3.0V	8.0V	-																																																																										
 <p>521-9185 red non diffused 521-9186 red diffused</p>	<p>Maximum Ratings</p> <table border="1"> <tr> <td>Forward DC Current</td> <td>40 mA</td> </tr> <tr> <td>Reverse Voltage</td> <td>3.0V</td> </tr> <tr> <td>Power dissipation -(Derate 1.1 mW/°C above 25°C)</td> <td>80 mW</td> </tr> <tr> <td>Storage and Operating Temperature Range</td> <td>-55°C to 100°C</td> </tr> </table> <p>Radiant Characteristics</p> <table border="1"> <thead> <tr> <th>Parameters</th> <th>Typical</th> <th>Maximum</th> <th>Units</th> </tr> </thead> <tbody> <tr> <td>Luminance (Brightness) @ I_F=20 mA</td> <td>750</td> <td></td> <td>ft-L</td> </tr> <tr> <td>Current to Produce 50 Ft-L</td> <td>2</td> <td>10</td> <td>mA</td> </tr> <tr> <td>Rise and Fall Time</td> <td>1.0</td> <td></td> <td>nS</td> </tr> </tbody> </table> <p>Electrical Characteristics</p> <table border="1"> <thead> <tr> <th>Parameters</th> <th>Typical</th> <th>Maximum</th> <th>Units</th> </tr> </thead> <tbody> <tr> <td>Forward Voltage @ I_F=20 mA</td> <td>1.6</td> <td>2.0</td> <td>V</td> </tr> <tr> <td>Reverse Current @ -3.0V</td> <td>100</td> <td></td> <td>nA</td> </tr> <tr> <td>Capacitance @ V=0</td> <td>90</td> <td></td> <td>pF</td> </tr> </tbody> </table>	Forward DC Current	40 mA	Reverse Voltage	3.0V	Power dissipation -(Derate 1.1 mW/°C above 25°C)	80 mW	Storage and Operating Temperature Range	-55°C to 100°C	Parameters	Typical	Maximum	Units	Luminance (Brightness) @ I _F =20 mA	750		ft-L	Current to Produce 50 Ft-L	2	10	mA	Rise and Fall Time	1.0		nS	Parameters	Typical	Maximum	Units	Forward Voltage @ I _F =20 mA	1.6	2.0	V	Reverse Current @ -3.0V	100		nA	Capacitance @ V=0	90		pF																																					
Forward DC Current	40 mA																																																																													
Reverse Voltage	3.0V																																																																													
Power dissipation -(Derate 1.1 mW/°C above 25°C)	80 mW																																																																													
Storage and Operating Temperature Range	-55°C to 100°C																																																																													
Parameters	Typical	Maximum	Units																																																																											
Luminance (Brightness) @ I _F =20 mA	750		ft-L																																																																											
Current to Produce 50 Ft-L	2	10	mA																																																																											
Rise and Fall Time	1.0		nS																																																																											
Parameters	Typical	Maximum	Units																																																																											
Forward Voltage @ I _F =20 mA	1.6	2.0	V																																																																											
Reverse Current @ -3.0V	100		nA																																																																											
Capacitance @ V=0	90		pF																																																																											
 <p>521-9189 red diffused</p>	<p>operating characteristics at 25°C ambient air temperature</p> <table border="1"> <thead> <tr> <th>Parameter</th> <th>Test Conditions</th> <th>Min</th> <th>Typ</th> <th>Max</th> <th>Unit</th> </tr> </thead> <tbody> <tr> <td>P_O</td> <td>Radiant Power Output I_F= 20 mA</td> <td></td> <td>15</td> <td></td> <td>μW</td> </tr> <tr> <td>λ_p</td> <td>Wavelength at Peak Emission I_F= 20 mA</td> <td>6300</td> <td>6500</td> <td>6700</td> <td>Å</td> </tr> <tr> <td>V_F</td> <td>Static Forward Voltage I_F= 20 mA</td> <td>1.6</td> <td>2</td> <td></td> <td>V</td> </tr> <tr> <td>I_R</td> <td>Static Reverse Current V_R= 3V</td> <td></td> <td>0.1</td> <td></td> <td>μA</td> </tr> </tbody> </table> <p>Maximum Ratings</p> <table border="1"> <tr> <td>Reverse Voltage at 25°C Ambient-Air Temperature</td> <td>3V</td> </tr> <tr> <td>Continuous Forward Current at (or below) 25°C Ambient-Air Temperature (See Note 1)</td> <td>40 mA</td> </tr> <tr> <td>Storage Temperature Range</td> <td>-40°C to 80°C</td> </tr> <tr> <td>Lead Temperature 1/16 Inch from Case for 5 Seconds</td> <td>230°C</td> </tr> </table> <p>Note 1: Derate linearly to 70°C ambient-air temperature at the rate of 0.89 mA/°C.</p>	Parameter	Test Conditions	Min	Typ	Max	Unit	P _O	Radiant Power Output I _F = 20 mA		15		μW	λ _p	Wavelength at Peak Emission I _F = 20 mA	6300	6500	6700	Å	V _F	Static Forward Voltage I _F = 20 mA	1.6	2		V	I _R	Static Reverse Current V _R = 3V		0.1		μA	Reverse Voltage at 25°C Ambient-Air Temperature	3V	Continuous Forward Current at (or below) 25°C Ambient-Air Temperature (See Note 1)	40 mA	Storage Temperature Range	-40°C to 80°C	Lead Temperature 1/16 Inch from Case for 5 Seconds	230°C																																							
Parameter	Test Conditions	Min	Typ	Max	Unit																																																																									
P _O	Radiant Power Output I _F = 20 mA		15		μW																																																																									
λ _p	Wavelength at Peak Emission I _F = 20 mA	6300	6500	6700	Å																																																																									
V _F	Static Forward Voltage I _F = 20 mA	1.6	2		V																																																																									
I _R	Static Reverse Current V _R = 3V		0.1		μA																																																																									
Reverse Voltage at 25°C Ambient-Air Temperature	3V																																																																													
Continuous Forward Current at (or below) 25°C Ambient-Air Temperature (See Note 1)	40 mA																																																																													
Storage Temperature Range	-40°C to 80°C																																																																													
Lead Temperature 1/16 Inch from Case for 5 Seconds	230°C																																																																													
 <p>549 Series Bi-Pin Lamp</p>	<table border="1"> <thead> <tr> <th>Catalog Numbers</th> <th>Volts-</th> <th>mA</th> </tr> </thead> <tbody> <tr> <td>549-0101</td> <td>1.7</td> <td>*</td> </tr> <tr> <td>549-0102</td> <td>3.6</td> <td>20 +</td> </tr> <tr> <td>549-0103</td> <td>5</td> <td>6</td> </tr> <tr> <td>549-0104</td> <td>5</td> <td>16 △</td> </tr> <tr> <td>549-0105</td> <td>10</td> <td>14</td> </tr> <tr> <td>549-0106</td> <td>14</td> <td>10</td> </tr> </tbody> </table> <p>For use as an indicator. Is directly interchangeable with T-1 3/4 incandescent equivalent.</p> <p>* Requires external resistor. Maximum forward DC current 50 mA. Typical operating current 20 mA. + For higher brightness can be operated at 5V @ 30 mA. △ For higher brightness can be operated at 6V @ 20 mA.</p>	Catalog Numbers	Volts-	mA	549-0101	1.7	*	549-0102	3.6	20 +	549-0103	5	6	549-0104	5	16 △	549-0105	10	14	549-0106	14	10																																																								
Catalog Numbers	Volts-	mA																																																																												
549-0101	1.7	*																																																																												
549-0102	3.6	20 +																																																																												
549-0103	5	6																																																																												
549-0104	5	16 △																																																																												
549-0105	10	14																																																																												
549-0106	14	10																																																																												

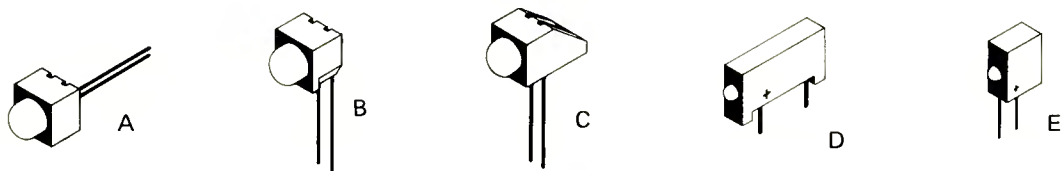

LED LOGIC/STATE FAULT INDICATORS

SERIES	ILLUS	VOLTS	TERMINAL TYPE	SPECIAL FEATURES	DATA IN CAT. NO.
550-0101	A	1.8V typ @ 50 mA	Pin	PC board or DIP socket mounting	SG731
550-0102	B	1.8V typ @ 50 mA	Pin	PC board or DIP socket mounting	SG731
550-0103	C	1.8V typ @ 50 mA	Pin	PC board or DIP socket mounting	SG731
547-	D	1.7; 3.6; 5; 10; 14	Pin	PC board or DIP socket mounting	SG731
555-	E	1.7; 3.6; 5; 10; 14	Pin	PC board or DIP socket mounting	SG731



SUB-SUB-MINIATURE INDICATOR LIGHTS

These series indicator lights mount in .193" clearance hole—and have permanently enclosed T-1 incandescent bulbs rated 5V. .06 Amp or 6.3V. .07 Amp.

SERIES	MTG. CLEAR. HOLE	PANEL INSERTION (F) FRONT (B) BACK	MAX. PANEL THICKNS.	LAMP ACCOMMO. & V. RANGE	LENS SHAPE	TERMINAL TYPE	SPECIAL FEATURES	DATA IN CAT. NO.
252-9951	.193"	F	5/32"	T-1 5-6.3V	Stovepipe	Wire Leads	Per MIL-L-3661B or MS25446 per MIL-L-6723	L-168 CR680

ULTRA-MINIATURE INDICATOR LIGHTS

With one exception, all ultra-miniature indicator lights mount in 3/8" clearance hole. The exception is the twin lamp indicators (see 253 and 365 Series) which mount in 3/4" clearance hole.

The indicators described in Catalog UM1200 (referred to as Datalites) consist of:

- 1 - the holder
- 2 - the lamp cartridge which plugs into the holder and makes electrical contact as the pins enter the receptacles in the holder
- 3 - optional data cap

Plug-in lamp cartridges may be Incandescent, Neon or Solid State LED.

Incandescent Datalamp Cartridges: Contain T-1 3/4 bulb, available in a range of voltages from 1.35 to 120V.

Neon Datalamp Cartridges: Contain A1B or A9A (NE-2E) standard, brightness bulb available in a range of voltages from 105-125V AC-DC; A1C or C2A (NE-2H) high brightness bulb available from 110-125V AC only. Cartridges can be obtained with or without built-in current-limiting resistor.

LED Datalamp Cartridges: Contain solid state LEDs as the light source, in a range of voltages from 3.6 to 28 VDC. For operation directly from RTL, DTL or TTL logic, the 10 mA cartridge is recommended; for optimum brightness, the 20 mA is recommended.

Permanent Indicators with Neon Lamps: (described in Catalog UM1200 contain non-replaceable T-2 neon lamps. The high brightness type is designated as C2A (NE-2H) and the standard brightness as A9A (NE-2E). The former operate on 110-125V AC circuits, the latter on 105-125V DC circuits. This group is available with or without built-in current-limiting resistor.

Permanent Indicators with LED light source: available from 3.6 to 28 VDC at maximum current of 20 mA.

HOLDERS – ACCOMMODATE DATALAMP CARTRIDGES *

* Datalamp cartridges are listed at the end of this section—See 507 Series.

See Note 1 on page 2.

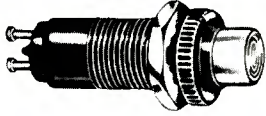

A



A

SERIES	ILLUS.	MTG. CLEAR. HOLE	PANEL INSERTION (F) FRONT (B) BACK	MAX. PANEL THICKNS.	LENS SHAPE	TERMINAL TYPE	SPECIAL FEATURES	DATA IN CAT. NO.
249-7867	A	3/8"	B	5/16"	Cylindrical, Stovepipe	Turret	LED	UM1200
249-7868	A	3/8"	B	5/16"	Cylindrical, Stovepipe	Turret	LED	UM1200
249-7869	A	3/8"	B	5/16"	Cylindrical, Stovepipe	Turret	LED	UM1200
249-7870	A	3/8"	B	5/16"	Cylindrical, Stovepipe	Turret	LED	UM1200
249-7871	A	3/8"	B	5/16"	Cylindrical, Stovepipe	Turret	LED	UM1200
249-7872	A	3/8"	B	5/16"	Cylindrical, Stovepipe	Turret	LED	UM1200
250-7538	B	3/8"	B	3/16"	Cylindrical	Solder Cup		UM1200
250-7545	B	3/8"	B	3/16"	Cylindrical	Solder Cup		UM1200
250-7558	B	3/8"	B	11/32"	Cylindrical	Solder Cup		UM1200
250-8738	B	3/8"	B	3/16"	Cylindrical	Turret		UM1200
250-8745	B	3/8"	B	3/16"	Cylindrical	Turret		UM1200
250-8758	B	3/8"	B	11/32"	Cylindrical	Turret		UM1200
250-9038	B	3/8"	B	3/16"	Cylindrical	Amp "53" Taper Pin Receptacles		UM1200
250-9045	B	3/8"	B	3/16"	Cylindrical	Amp "53" Taper Pin Receptacles		UM1200
251-7538	C	3/8"	B	5/16"	Cylindrical	Solder Cup	RFI Data Cap. Contact factory	-----
251-7545	C	3/8"	B	3/16"	Cylindrical	Solder Cup	RFI Data Cap. Contact factory	-----
251-7558	C	3/8"	B	5/16"	Cylindrical	Solder Cup	RFI Data Cap. Contact factory	-----
251-8738	C	3/8"	B	5/16"	Cylindrical	Turret	RFI Data Cap. Contact factory	-----
251-8745	C	3/8"	B	3/16"	Cylindrical	Turret	RFI Data Cap. Contact factory	-----
251-8758	C	3/8"	B	5/16"	Cylindrical	Turret	RFI Data Cap. Contact factory	-----
251-9038	C	3/8"	B	5/16"	Cylindrical	Amp "53" Taper Pin Receptacles	RFI Data Cap. Contact factory	-----
251-9045	C	3/8"	B	3/16"	Cylindrical	Amp "53" Taper Pin Receptacles	RFI Data Cap. Contact factory	-----

See Note 1 on page 2.



B

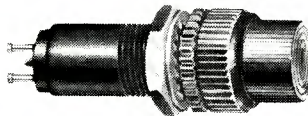

B



C

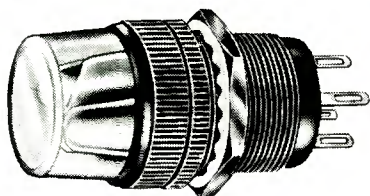

D

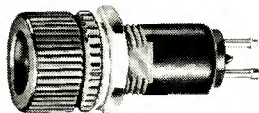

E

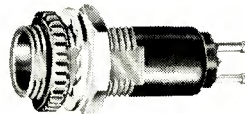

F

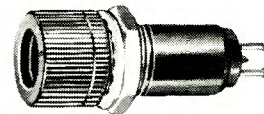

G

SERIES.	ILLUS.	MTG. CLEAR. HOLE	PANEL INSERTION (F) FRONT (B) BACK	MAX. PANEL THICKNS.	LENS SHAPE	TERMINAL TYPE	SPECIAL FEATURES	DATA IN CAT. NO.
253-6939	D	3/4"	F/B	5/16"	Cylindrical	Solder	Accommodate two lamp cartridges	UM1200
253-6945	D	3/4"	F/B	5/16"	Cylindrical	Solder	Accommodate two lamp cartridges	UM1200
365-6939	D	3/4"	F/B	5/16"	Cylindrical	Solder	Accommodate two lamp cartridges – Meets MIL-L-3661B	UM1200 CR680
370-8738	E	3/8"	B	5/32"		Turret	Meets MIL-L-3661B	UM1200 CR680
371-8738	F	3/8"	B	5/32"	Cylindrical	Turret	Meets MIL-L-3661B	UM1200 CR680
371-8760	F	3/8"	B	5/32"		Turret	Meets MIL-L-3661B	UM1200 CR680
508-7538	G	3/8"	B	5/32"		Solder Cup		UM1200
508-7545	G	3/8"	B	5/32"		Solder Cup		UM1200
508-8738	G	3/8"	B	5/32"		Turret		UM1200
508-8745	G	3/8"	B	5/32"		Turret		UM1200
508-9038	G	3/8"	B	5/32"		Amp "53" Taper Pin Receptacles		UM1200
508-9045	G	3/8"	B	5/32"		Receptacles Amp "53" Taper Pin Receptacles		UM1200
510-	—	—	F	—	—	—	Data Strip – Horizontal	UM1200
511-	—	—	F	—	—	—	Data Strip – Vertical	UM1200
512-	—	—	F	—	—	—	Data Matrix – Contact factory	UM1200
515-0012	H	—	—	—	—	Solder Cup	Cartridge Connector	UM1200
515-0050	J	—	—	—	—	Solder Blade	Cartridge Connector	UM1200
515-0051	K	—	B	—	—	—	Speed Clip	UM1200
515-0074	L	—	—	—	—	Solder Blade	Cartridge Connector	UM1200



H



J



K



L

See Note 1 on page 2.

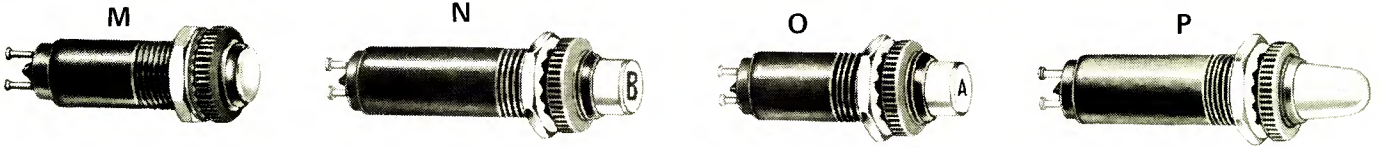

PERMANENT LAMP INDICATOR LIGHTS
NEON

SERIES	ILLUS.	MTG. CLEAR. HOLE	PANEL INSERTION (F) FRONT (B) BACK	MAX. PANEL THICKNS.	LAMP ACCOMMO. & V. RANGE	LENS SHAPE	TERMINAL TYPE	SPECIAL FEATURES	DATA IN CAT. NO.
249-7840	M	3/8"	B	5/16"	105-125V AC-DC	Stovepipe, Flat, Cylindrical	Turret	Standard brightness, no built-in resistor	UM1200
249-7841	N	3/8"	B	5/16"	105-125V AC-DC	Stovepipe, Flat, Cylindrical	Turret	Standard brightness, w/built-in resistor	UM1200
249-7865	O	3/8"	B	5/16"	110-125V AC	Stovepipe, Flat, Cylindrical	Turret	High brightness, no built-in resistor	UM1200
249-7866	P	3/8"	B	5/16"	110-125V AC	Stovepipe, Flat, Cylindrical	Turret	High brightness, w/built-in resistor	UM1200
250-7840	Q	3/8"	B	3/16"	105-125V AC-DC	Cylindrical	Turret	Standard brightness, no built-in resistor	UM1200
250-7841	R	3/8"	B	3/16"	105-125V AC-DC	Data Cap Cylindrical	Turret	Standard brightness, w/built-in resistor	UM1200
250-7865	Q	3/8"	B	3/16"	110-125V AC	Data Cap Cylindrical	Turret	High brightness, no built-in resistor	UM1200
250-7866	R	3/8"	B	3/16"	110-125V AC	Data Cap Cylindrical	Turret	High brightness, w/built-in resistor	UM1200
911-1112	S	3/8"	B	3/16"	T-1 3/4 Incand. 1.35-28V or Neon T-2 105-125V	Cylindrical	Solder	Neon unit requires externally mtd. current limiting resistor	L-210
915-1118	T	3/8"	B	3/16"	105-125V AC-DC	Stovepipe, Cylindrical	Amp "53" Taper Pin Receptacles	3 terminals Standard brightness, no built-in resistor	UM1200
915-1119	T	3/8"	B	3/16"	110-125V AC	Stovepipe, Cylindrical	Amp "53" Taper Pin Receptacles	3 terminals High brightness, no built-in resistor	UM1200
915-1120	T	3/8"	B	3/16"	105-125V AC-DC	Stovepipe, Cylindrical	Amp "53" Taper Pin Receptacles	3 terminals Standard brightness, w/built-in resistor	UM1200
915-1121	T	3/8"	B	3/16"	110-125V AC	Stovepipe, Cylindrical	Amp "53" Taper Pin Receptacles	3 terminals High brightness, w/built-in resistor	UM1200
915-1207	T	3/8"	B	3/16"	105-125V AC-DC	Stovepipe, Cylindrical	Amp "53" Taper Pin Receptacles	3 terminals Standard brightness, w/built-in resistor	UM1200
915-1208	T	3/8"	B	3/16"	110-125V AC	Stovepipe, Cylindrical	Amp "53" Taper Pin Receptacles	3 terminals High brightness, w/built-in resistor	UM1200

See Note 1 on page 2.

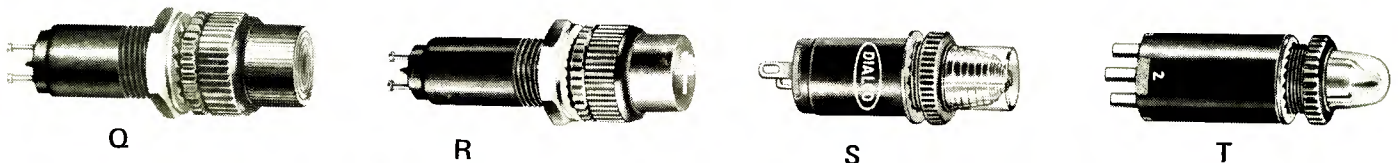

See Note 1 on page 2.

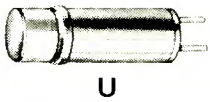

U

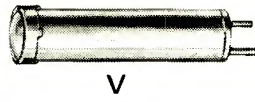

V



W

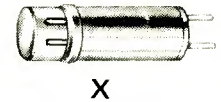

X

SERIES	ILLUS.	MTG. CLEAR. HOLE	PANEL INSERTION (F) FRONT (B) BACK	V. RANGE	LENS SHAPE	TERMINAL TYPE	SPECIAL FEATURES	DATA IN CAT. NO.
--------	--------	------------------	------------------------------------	----------	------------	---------------	------------------	------------------

INCANDESCENT DATALAMP PLUG-IN CARTRIDGES

507-39XX	U	9/32"	F	1.35-28V * See note below	Short Cyl., Flat	Pin	MS18235 – MS18237; also no MS designations	UM1200 CR680
507-58XX	V	9/32"	F	6-120V	Plano-Convex	Pin		UM1200
507-6022	W	9/32"	F	48V	Cylindrical	Pin	MS18238-1	UM1200 CR680
507-6023	W	9/32"	F	60V	Cylindrical	Pin	MS18238-2	UM1200 CR680

* See page 8 for T-1 3/4 lamp chart.

NEON DATALAMP PLUG-IN CARTRIDGES

507-38XX	X	9/32"	F	105-125V	Stovepipe, Cylindrical	Pin		UM1200
507-45XX	X	9/32"	F	105-125V	Stovepipe, Cylindrical	Pin		UM1200
507-5337	X	9/32"	F	105-125V AC-DC	Stovepipe, Cylindrical	Pin	MS18236 – MS18237; also no MS designations.	UM1200 CR680
507-5338	X	9/32"	F	110-125V AC	Stovepipe, Cylindrical	Pin	MS18236 – MS18237; also no MS designations.	UM1200 CR680
507-5838	Y	9/32"	F	110-125V AC	Cylindrical	Pin		UM1200

LED DATALAMP PLUG-IN CARTRIDGES

507-4756	Z	9/32"	F	3.6 - 28 VDC	Cylindrical, Stovepipe	Pin	LED	UM1200
507-4757	Z	9/32"	F	3.6 - 28 VDC	Cylindrical, Stovepipe	Pin	LED	UM1200
507-4758	Z	9/32"	F	3.6 - 28 VDC	Cylindrical, Stovepipe	Pin	LED	UM1200
507-4759	Z	9/32"	F	3.6 - 28 VDC	Cylindrical, Stovepipe	Pin	LED	UM1200
507-4760	Z	9/32"	F	3.6 - 28 VDC	Cylindrical, Stovepipe	Pin	LED	UM1200
507-4761	Z	9/32"	F	3.6 - 28 VDC	Cylindrical, Stovepipe	Pin	LED	UM1200

See Note 1 on page 2.



X

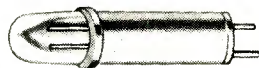

X



Y

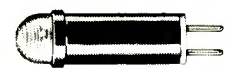

Z

SUB-MINIATURE INDICATOR LIGHTS

The indicator lights listed in this section mount in 13/32" to 17/32" clearance hole.

Incandescent Indicator Lights accommodate a T-1 3/4 bulb with midget flanged base — in a range of voltages from 1.35 to 28V. A lamp chart with full data is provided for your reference.

Neon Indicator Lights accommodate C7A or C9A (NE-2J) replaceable T-2 neon glow lamps with midget flanged base (listed as T-2 M.F.B.). Neon lamps require a resistor (or other ballast device) to limit the lamp current. Dialco makes the required resistor an integral part (built-in) — a patented Dialight feature, U.S. Pat. No. 2,421,321 in a number of the series in this section. Other listed series require the addition of an external resistor.

INCANDESCENT

SERIES	ILLUS.	MTG. CLEAR. HOLE	PANEL INSERTION (F) FRONT (B) BACK	MAX. PANEL THICKNS.	LAMP ACCOMMO. & V. RANGE	LENS SHAPE	TERMINAL TYPE	SPECIAL FEATURES	DATA IN CAT. NO.
2-1830	A	15/32"	F	17/64"	T-1 3/4 M.F.B. 1.35-28V	Convex	Screw	Dimmer-Mechanical	L-157
2-1930	A	15/32"	F	17/64"	T-1 3/4 M.F.B. 1.35-28V	Convex	Solder	Dimmer-Mechanical	L-157
2-3730	A	15/32"	F	5/32"	T-1 3/4 M.F.B. 1.35-28V	Convex	Solder	Dimmer-Mechanical, extended neck for plastic panel mtg.	L-158
2-4930	A	15/32"	F	5/32"	T-1 3/4 M.F.B. 1.35-28V	Convex	Screw	Dimmer-Mechanical extended neck for plastic panel mtg.	L-158
3-1830	A	15/32"	F	17/64"	T-1 3/4 M.F.B. 1.35-28V	Convex	Screw	Dimmer-Polaroid	L-157
3-1930	A	15/32"	F	17/64"	T-1 3/4 M.F.B. 1.35-28V	Convex	Solder	Dimmer-Polaroid	L-157
3-3730	A	15/32"	F	5/32"	T-1 3/4 M.F.B. 1.35-28V	Convex	Solder	Dimmer-Mechanical, extended neck for plastic panel mtg. polaroid.	L-158
3-4930	A	15/32"	F	5/32"	T-1 3/4 M.F.B. 1.35-28V	Convex	Screw	Dimmer-Mechanical, extended neck for plastic panel mtg. polaroid.	L-158
4-1830	B	15/32"	F	17/64"	T-1 3/4 M.F.B. 1.35-28V	-----	Screw	Light Shield	L-157
4-1930	B	15/32"	F	17/64"	T-1 3/4 M.F.B. 1.35-28V	-----	Solder	Light Shield	L-157

See Note 1 on page 2.

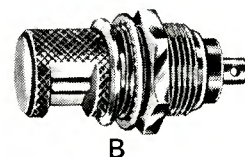
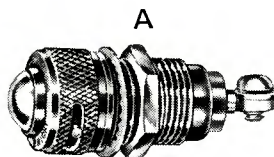
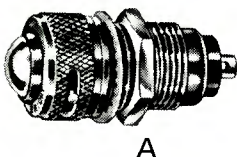

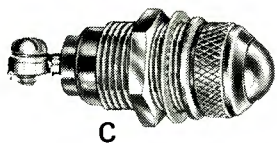

C

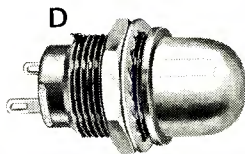

D

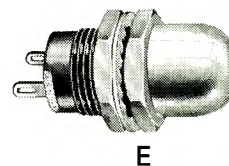

E

See Note 1 on page 2.

SERIES	ILLUS.	MTG. CLEAR. HOLE	PANEL INSERTION (F) FRONT (B) BACK	MAX. PANEL THICKNS.	LAMP ACCOMMO. & V. RANGE	LENS SHAPE	TERMINAL TYPE	SPECIAL FEATURES	DATA IN CAT. NO.
8-1830	C	15/32"	F	3/8"	T-1 3/4 M.F.B. 1.35-28V	Convex	Screw	Non-Dimming	L-157
8-1930	C	15/32"	F	3/8"	T-1 3/4 M.F.B. 1.35-28V	Convex	Solder	Non-Dimming	L-157
8-3730	C	15/32"	F	5/32"	T-1 3/4 M.F.B. 1.35-28V	Convex	Solder	Non-Dimming, extended neck for plastic panel mtg.	L-158
8-4930	C	15/32"	F	5/32"	T-1 3/4 M.F.B. 1.35-28V	Convex	Screw	Non-Dimming, extended neck for plastic panel mtg.	L-158
11-1830	A*	15/32"	F	17/64"	T-1 3/4 M.F.B. 1.35-28V	Convex	Screw	Dimmer-Mechanical	L-157
11-1930	A*	15/32"	F	17/64"	T-1 3/4 M.F.B. 1.35-28V	Convex	Solder	Dimmer-Mechanical	L-157
11-3730	A*	15/32"	F	5/32"	T-1 3/4 M.F.B. 1.35-28V	Convex	Solder	Dimmer-Mechanical extended neck for plastic panel mtg.	L-158
11-4930	A*	15/32"	F	5/32"	T-1 3/4 M.F.B. 1.35-28V	Convex	Screw	Dimmer-Mechanical; extended neck for plastic panel mtg.	L-158
101-3830	E	15/32"	F/B	1/4"	T-1 3/4 M.F.B. 1.35-28V	Stovepipe	Solder		L-178
101-4630	G	13/32"	F	7/32"	T-1 3/4 M.F.B. 1.35-28V	Stovepipe	Solder		L-157
101-5030	D	17/32"	F	1/4"	T-1 3/4 M.F.B. 1.35-28V	Stovepipe	Solder		L-178
101-7130	G	13/32"	F	7/32"	T-1 3/4 M.F.B. 1.35-28V	Stovepipe	Screw		L-157
101-8430	D	15/32"	F	1/4"	T-1 3/4 M.F.B. 1.35-28V	Stovepipe	Solder		L-178
106-1830	F	15/32"	F	17/64"	T-1 3/4 M.F.B. 1.35-28V	Flat	Screw	Two pc. lens cap. Rotatable. For use with hot-stamped or engraved legend.	L-157
106-1930	F	15/32"	F	17/64"	T-1 3/4 M.F.B. 1.35-28V	Flat	Solder	Two pc. lens cap. Rotatable. For use with hot-stamped or engraved legend.	L-157
107-1830	G	15/32"	F	9/32"	T-1 3/4 M.F.B. 1.35-28V	Stovepipe	Screw		L-157
107-1930	G	15/32"	F	9/32"	T-1 3/4 M.F.B. 1.35-28V	Stovepipe	Solder		L-157
108-3830	H	15/32"	F/B	1/4"	T-1 3/4 M.F.B. 1.35-28V	Convex	Solder	Dimmer-Mechanical	L-178
108-5030	J**	17/32"	F	1/4"	T-1 3/4 M.F.B. 1.35-28V	Convex	Solder	Dimmer-Mechanical	L-178
108-8430	L**	15/32"	F	1/4"	T-1 3/4 M.F.B. 1.35-28V	Convex	Solder	Dimmer-Mechanical	L-178

See Note 1 on page 2.

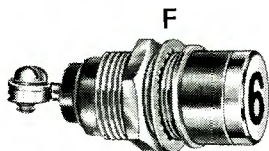

F

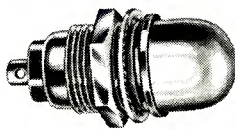

G

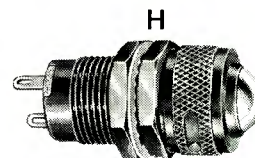

H

See Note 1 on page 2.

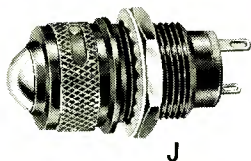

J

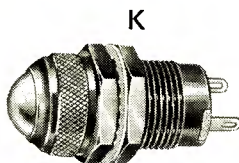

K



L

SERIES	ILLUS.	MTG. CLEAR. HOLE	PANEL INSERTION (F) FRONT (B) BACK	MAX. PANEL THICKNS.	LAMP ACCOMMO. & V. RANGE	LENS SHAPE	TERMINAL TYPE	SPECIAL FEATURES	DATA IN CAT. NO.
109-3830	H*	15/32"	F/B	1/4"	T-1 3/4 M.F.B. 1.35-28V	Convex	Solder	Dimmer-Mechanical	L-178
109-5030	J	17/32"	F	1/4"	T-1 3/4 M.F.B. 1.35-28V	Convex	Solder	Dimmer-Mechanical	L-178
109-8430	L	15/32"	F	1/4"	T-1 3/4 M.F.B. 1.35-28V	Convex	Solder	Dimmer-Mechanical	L-178
111-3830	K	15/32"	F/B	1/4"	T-1 3/4 M.F.B. 1.35-28V	Convex	Solder	Non-Dimming	L-178
111-4630	G*	13/32"	F	3/8"	T-1 3/4 M.F.B. 1.35-28V	Convex	Solder	Non-Dimming	L-157
111-5030	K	17/32"	F	1/4"	T-1 3/4 M.F.B. 1.35-28V	Convex	Solder	Non-Dimming	L-178
111-7130	G*	13/32"	F	3/8"	T-1 3/4 M.F.B. 1.35-28V	Convex	Screw	Non-Dimming	L-157
111-8430	K	15/32"	F	1/4"	T-1 3/4 M.F.B. 1.35-28V	Convex	Solder	Non-Dimming	L-178
112-3830	H*	15/32"	F/B	1/4"	T-1 3/4 M.F.B. 1.35-28V	Convex	Solder	Dimmer-Polaroid	L-178
112-5030	J	17/32"	F	1/4"	T-1 3/4 M.F.B. 1.35-28V	Convex	Solder	Dimmer-Polaroid	L-178
112-8430	L	15/32"	F	1/4"	T-1 3/4 M.F.B. 1.35-28V	Convex	Solder	Dimmer-Polaroid	L-178
113-1830	M	15/32"	F	17/64"	T-1 3/4 M.F.B. 1.35-28V	Molded filter	Screw	Light Shield	L-157
113-1930	M	15/32"	F	17/64"	T-1 3/4 M.F.B. 1.35-28V	Molded filter	Solder	Light Shield	L-157
134-3830	N	15/32"	F/B	1/4"	T-1 3/4 M.F.B. 1.35-28V	Flat, Convex, Faceted	Solder	Rotatable flat lens	L-178
134-5030	N	17/32"	F	1/4"	T-1 3/4 M.F.B. 1.35-28V	Flat, Convex, Faceted	Solder	Rotatable flat lens	L-178
134-8430	N	15/32"	F	1/4"	T-1 3/4 M.F.B. 1.35-28V	Flat, Convex, Faceted	Solder	Rotatable flat lens	L-178
140-3830	O	15/32"	F/B	1/4"	T-1 3/4 M.F.B. 1.35-28V	Cylindrical	Solder		L-178
140-5030	O	17/32"	F	1/4"	T-1 3/4 M.F.B. 1.35-28V	Cylindrical	Solder		L-178
140-8430	O	15/32"	F	1/4"	T-1 3/4 M.F.B. 1.35-28V	Cylindrical	Solder		L-178

See Note 1 on page 2.

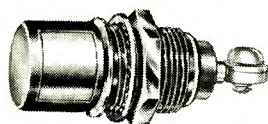

M



N

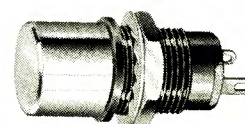

O

See Note 1 on page 2.

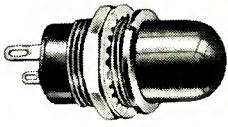

P

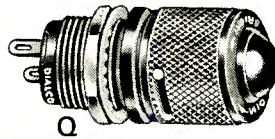

Q

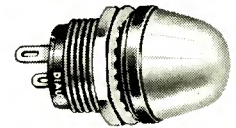

R

SERIES	ILLUS.	MTG. CLEAR. HOLE	PANEL INSERTION (F) FRONT (B) BACK	MAX. PANEL THICKNS.	LAMP ACCOMMO. & V. RANGE	LENS SHAPE	TERMINAL TYPE	SPECIAL FEATURES	DATA IN CAT. NO.
162-8430	P	15/32"	F	3/16"	T-1 3/4 M.F.B. 1.35-28V	Stovepipe	Solder	MS25256 2-12. Also 359 and 362 RFI Series, each MIL-L-3661B.	L-178
162-8430	P	15/32"	F	3/16"	T-1 3/4 M.F.B. 1.35-28V	Cylindrical	Solder	No MS designations	L-178
174-8430	Q	15/32"	F	1/4"	T-1 3/4 M.F.B. 1.35-28V	Convex	Solder	Water-tight; Mechanical Dimmer. Also 368 Series (MIL-L-3661B).	L-178
175-8430	Q	15/32"	F	1/4"	T-1 3/4 M.F.B. 1.35-28V	Convex	Solder	Water-tight; Mechanical Dimmer. Also 369 Series (MIL-L-3661B).	L-178
177-8430	R	15/32"	F	3/16"	T-1 3/4 M.F.B. 1.35-28V	Stovepipe	Solder	Water-tight. Also 367 Series (MIL-L-3661B).	L-178
178-8430	S	15/32"	F	3/16"	T-1 3/4 M.F.B. 1.35-28V	Flat, Convex, Faceted	Solder	Rotatable lens. Also 359 and 363 RFI Series, each MIL-L-3661B.	L-178
183-9730	T	15/32"	F	3/16"	T-1 3/4 M.F.B. 1.35-28V	Round	Solder	Friction-fit. 1/2" rotatable lens cap.	L-178
183-9830	T	1/2"	F/B	1/8"	T-1 3/4 M.F.B. 1.35-28V	Round	Solder	Friction-fit. 1/2" rotatable lens cap.	L-178
184-9730	U	15/32"	F	3/16"	T-1 3/4 M.F.B. 1.35-28V	Square	Solder	Friction-fit. 1/2" non-rotatable lens cap.	L-178
184-9830	U	1/2"	F/B	1/8"	T-1 3/4 M.F.B. 1.35-28V	Square	Solder	Friction-fit. 1/2" non-rotatable lens cap.	L-178
185-9730	U	15/32"	F	3/16"	T-1 3/4 M.F.B. 1.35-28V	Square	Solder	Friction-fit. 1/2" rotatable lens cap.	L-178
185-9830	U	1/2"	F/B	1/8"	T-1 3/4 M.F.B. 1.35-28V	Square	Solder	Friction-fit. 1/2" rotatable lens cap.	L-178

See Note 1 on page 2.



S

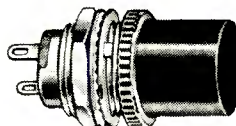

T

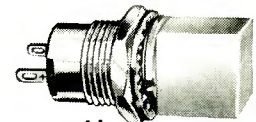

U

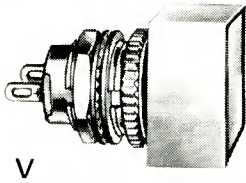

V

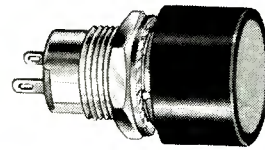

W

See Note 1 on page 2.

SERIES	ILLUS.	MTG. CLEAR. HOLE	PANEL INSERTION (F) FRONT (B) BACK	MAX. PANEL THICKNS.	LAMP ACCOMMO. & V. RANGE	LENS SHAPE	TERMINAL TYPE	SPECIAL FEATURES	DATA IN CAT. NO.
186-9730	T*	15/32"	F	3/16"	T-1 3/4 M.F.B. 1.35-28V	Round	Solder	Friction-fit. 1/2" non-rotatable lens cap.	L-178
186-9830	T*	1/2"	F/B	1/8"	T-1 3/4 M.F.B. 1.35-28V	Round	Solder	Friction-fit. 1/2" non-rotatable lens cap.	L-178
187-9730	V	15/32"	F	3/16"	T-1 3/4 M.F.B. 1.35-28V	Square	Solder	Friction-fit. 3/4" non-rotatable lens cap.	L-178
187-9830	V	1/2"	F/B	1/8"	T-1 3/4 M.F.B. 1.35-28V	Square	Solder	Friction-fit. 3/4" non-rotatable lens cap.	L-178
188-9730	W	15/32"	F	3/16"	T-1 3/4 M.F.B. 1.35-28V	Round	Solder	Friction-fit. 3/4" non-rotatable lens cap.	L-178
188-9830	W	1/2"	F/B	1/8"	T-1 3/4 M.F.B. 1.35-28V	Round	Solder	Friction-fit. 3/4" non-rotatable lens cap.	L-178
190-9730	V	15/32"	F	3/16"	T-1 3/4 M.F.B. 1.35-28V	Square	Solder	Friction-fit. 3/4" rotatable lens cap.	L-178
190-9830	V	1/2"	F/B	1/8"	T-1 3/4 M.F.B. 1.35-28V	Square	Solder	Friction-fit. 3/4" rotatable lens cap.	L-178
191-9730	W	15/32"	F	3/16"	T-1 3/4 M.F.B. 1.35-28V	Round	Solder	Friction-fit. 3/4" rotatable lens cap.	L-178
191-9830	W	1/2"	F/B	1/8"	T-1 3/4 M.F.B. 1.35-28V	Round	Solder	Friction-fit. 3/4" rotatable lens cap.	L-178
223-5030	—	17/32"	F	1/4"	T-1 3/4 M.F.B. 1.35-28V	Convex	Solder	RFI	—
270-1730	—	15/32"	F	7/32"	T-1 3/4 M.F.B. 1.35-28V	Edge Lighting	Solder	One terminal, grounded, hermetic seal.	L-158
270-1830	X	15/32"	F	7/32"	T-1 3/4 M.F.B. 1.35-28V	Edge Lighting	Screw	MS25010A11A thru MS25010A16A. Also w/o MS designations.	L-158
270-1930	X	15/32"	F	7/32"	T-1 3/4 M.F.B. 1.35-28V	Edge Lighting	Solder	MS25010B11A thru MS25010B16A. Also w/o MS designations.	L-158
271-8430	Y	15/32"	F	1/4"	T-1 3/4 M.F.B. 1.35-28V	Edge Lighting	Solder	MS25010C11B thru MS25010C16B. Also w/o MS designations.	L-158



X

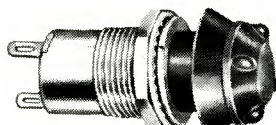

Y

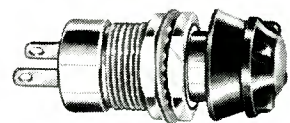

Z +

See Note 1 on page 2.

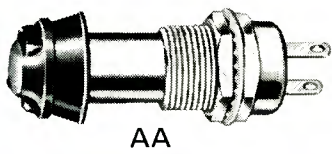

AA



BB

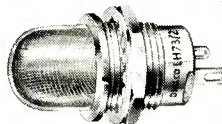

CC

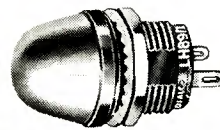

DD



EE

See Note 1 on page 2

SERIES	ILLUS.	MTG. CLEAR. HOLE	PANEL INSERTION (F) FRONT (B) BACK	MAX. PANEL THICKNS	LAMP ACCOMMO. & V. RANGE	LENS SHAPE	TERMINAL TYPE	SPECIAL FEATURES	DATA IN CAT. NO.
272-3830	Z*	15/32"	B	17/64"	T-1 3/4 M.F.B. 1.35-28V	Edge Lighting	Solder		L-158
272-5030	Z*	17/32"	F	1/4"	T-1 3/4 M.F.B. 1.35-28V	Edge Lighting	Solder		L-158
273-3830	AA	15/32"	B	17/64"	T-1 3/4 M.F.B. 1.35-28V	Edge Lighting	Solder	Extended neck	L-158
273-5030	AA	17/32"	F	1/4"	T-1 3/4 M.F.B. 1.35-28V	Edge Lighting	Solder	Extended neck	L-158
274-1830	BB	15/32"	F	7/32"	T-1 3/4 M.F.B. 1.35-28V	Inset Lens	Screw		L-158
274-1930	BB	15/32"	F	7/32"	T-1 3/4 M.F.B. 1.35-28V	Inset Lens	Solder		L-158
359-8430	P*	15/32"	F	3/16"	T-1 3/4 M.F.B. 1.35-28V	Stovepipe, Cylindrical	Solder	Meets MIL-L-3661B reqmts. See series 162 and 178.	L-178
360-8430	S*	15/32"	F	1/4"	T-1 3/4 M.F.B. 1.35-28V	Flat	Solder	Meets MIL-L-3661B	CR680
362-8430	CC	15/32"	F	3/16"	T-1 3/4 M.F.B. 1.35-28V	Stovepipe, Cylindrical	Solder	RFI. Meets MIL-L-3661B. See 162 series.	L-178
363-8430	S*	15/32"	F	3/16"	T-1 3/4 M.F.B. 1.35-28V	Flat	Solder	RFI. Meets MIL-L-3661B. See 178 series.	L-178
367-8430	DD	15/32"	F	3/16"	T-1 3/4 M.F.B. 1.35-28V	Stovepipe	Solder	Meets MIL-L-3661B reqmts. See 177 series.	L-178
368-8430	EE	15/32"	F	1/4"	T-1 3/4 M.F.B. 1.35-28V	Convex	Solder	Meets MIL-L-3661B reqmts. See series 174 and 175.	L-178
369-8430	Q*	15/32"	F	3/16"	T-1 3/4 M.F.B. 1.35-28V	Convex	Solder	Meets MIL-L-3661B	CR680
NEON									
137-7236	FF	15/32"	F/B	1/4"	T-2 M.F.B. 105-125V	Stovepipe, Cylindrical	Solder	W/o built-in resistor.	L-178
137-7336	GG	17/32"	F	11/32"	T-2 M.F.B. 105-125V	Stovepipe, Cylindrical	Solder	W/o built-in resistor.	L-178
137-8536	GG	15/32"	F	11/32"	T-2 M.F.B. 105-125V	Stovepipe, Cylindrical	Solder	W/o built-in resistor.	L-178
137-8836	HH	15/32"	F	7/16"	T-2 M.F.B. 105-125V	Stovepipe	Solder	MS25257 1-6; also 361 series (MIL-L-3661B).	L-178

See Note 1 on page 2.

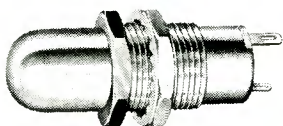

FF



GG

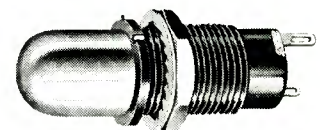

HH

* See illustrations P, Q, S and Z on pages 21-22

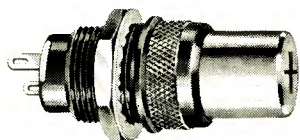

JJ



KK

SERIES	ILLUS.	MTG. CLEAR. HOLE	PANEL INSERTION (F) FRONT (B) BACK	MAX. PANEL THICKNS.	LAMP ACCOMMO. & V. RANGE	LENS SHAPE	TERMINAL TYPE	SPECIAL FEATURES	DATA IN CAT. NO.
137-8836	HH*	15/32"	F	7/16"	T-2 M.F.B. 105-125V AC-DC	Cylindrical	Solder	No MS designations. W/ built in resistor.	L-178
137-8864	HH*	15/32"	F	7/16"	T-2 M.F.B. 110-125V AC	Stovepipe Cylindrical	Solder	No MS designations. W/ built-in resistor. Also 361 series (MIL-L-3661B).	L-178
138-3836	JJ	15/32"	F/B	1/4"	T-2 M.F.B. 105-125V	Cylindrical	Solder	W/o built-in resistor.	L-178
138-5036	JJ	17/32"	F	1/4"	T-2 M.F.B. 105-125V	Cylindrical	Solder	W/o built-in resistor.	L-178
145-3836	KK	15/32"	F/B	1/4"	T-2 M.F.B. 105-125V	Stovepipe	Solder	W/o built-in resistor.	L-178
145-5036	KK	17/32"	F	1/4"	T-2 M.F.B. 105-125V	Stovepipe	Solder	W/o built-in resistor.	L-178
181-8536	LL	15/32"	F	11/32"	T-2 M.F.B. 105-125V	Stovepipe	Solder	Water-tight. W/o built-in resistor.	L-178
181-8836	LL	15/32"	F	11/32"	T-2 M.F.B. 105-125V AC-DC	Stovepipe	Solder	Water-tight. With built-in resistor. Also 366 series (MIL-L-3661B).	L-178
181-8864	LL	15/32"	F	11/32"	T-2 M.F.B. 110-125V AC	Stovepipe	Solder	Water-tight. With built-in resistor.	L-178
361-8836	HH*	15/32"	F	7/16"	T-2 M.F.B. 105-125V AC-DC	Stovepipe	Solder	Meets MIL-L-3661B reqmts. See 137 series.	L-178
361-8864	HH*	15/32"	F	7/16"	T-2 M.F.B. 110-125V AC	Stovepipe	Solder	Meets MIL-L-3661B reqmts. See 137 series.	L-178
364-8836	MM	15/32"	F	7/16"	T-2 M.F.B. 105-125V AC-DC	Stovepipe	Solder	RFI Meets MIL-L-3661B reqmts. See 137 series.	L-178
364-8864	MM	15/32"	F	7/16"	T-2 M.F.B. 110-125V AC	Stovepipe,	Solder	RFI. Meets MIL-L-3661B reqmts. See 137 series.	L-178
366-8836	NN	15/32"	F	11/32"	T-2 M.F.B. 105-125V AC-DC	Stovepipe	Solder	Meets MIL-L-3661B reqmts. See 181 series.	L-178

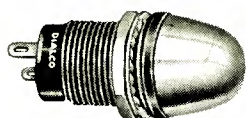

LL

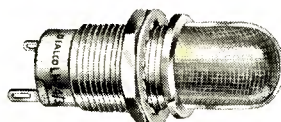

MM

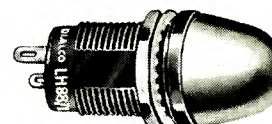

NN

MINIATURE INDICATOR LIGHTS

The indicator lights listed in this section mount in 7/16", 9/16" or 11/16" clearance hole. Those mounting in 7/16" clearance hole accommodate a T-2 bulb with telephone slide base and carry the following series numbers: 105-, 126-, 129- and 220-.

Incandescent Indicator Lights accommodate T-3 1/4 bulb with miniature bayonet base (listed as T-3 1/4 M.B.B.) in a range of voltages from 2-55V (these indicators will also accommodate T-3 bulb with miniature bayonet base, from 6-120 volts, and is indicated below with an (*) asterisk); or T-2 bulb with telephone slide base (listed as T-2 T.S.B.) from 6-120 volts.

Neon Indicator Lights accommodate B1A (NE-51) or B2A (NE-51H) neon glow lamps with miniature bayonet base-listed as B1A (NE-51) M.B.B. or B2A (NE-51H) M.B.B. The former is a standard brightness lamp for 105-125V AC-DC operation; the latter high brightness for either 110-125V AC or 210-250V AC-DC circuits. Dialco makes the required resistor an integral part (built-in – a patented Dialight feature – U.S. Pat. No. 2,421,321) in all of the series listed.

INCANDESCENT

SERIES	ILLUS.	MTG. CLEAR. HOLE	PANEL INSERTION (F) FRONT (B) BACK	MAX. PANEL THICKNS.	LAMP ACCOMMO. & V. RANGE	LENS SHAPE	TERMINAL TYPE	SPECIAL FEATURES	DATA IN CAT. NO.
17-0410	A	9/16"	B	3/8"	* T-3 1/4 M.B.B. 2-55V	Stovepipe	Solder	Screw-on cap	L-161
17-0428	A	9/16"	B	3/8"	T-2 T.S.B. 6-60V	Stovepipe	Solder	Screw-on cap	L-161
17-1310	A	9/16"	B	3/8"	* T-3 1/4 M.B.B. 2-55V	Stovepipe	Screw	Screw-on cap	L-161
17-1328	A	9/16"	B	3/8"	T-2 T.S.B. 6-60V	Stovepipe	Screw	Screw-on cap	L-161
21-0410	B	11/16"	F	9/32"	* T-3 1/4 M.B.B. 2-55V	-----	Solder	Light Shield cap	L-161
21-1310	B	11/16"	F	9/32"	* T-3 1/4 M.B.B. 2-55V	-----	Screw	Light Shield cap	L-161
22-0410	B	11/16"	F	9/32"	* T-3 1/4 M.B.B. 2-55V	-----	Solder	Light Shield cap	L-161
22-1310	B	11/16"	F	9/32"	* T-3 1/4 M.B.B. 2-55V	-----	Screw	Light Shield cap	L-161

See Note 1 on page 2.

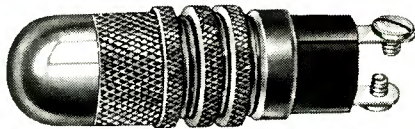

A

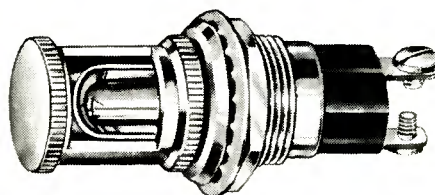

B

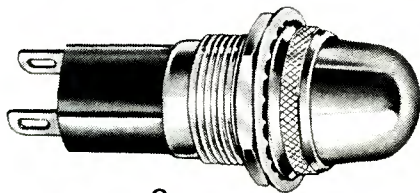

C

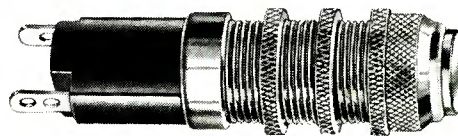

D

SERIES	ILLUS.	MTG. CLEAR. HOLE	PANEL INSERTION (F) FRONT (B) BACK	MAX. PANEL THICKNS	LAMP ACCOMMO. & V. RANGE	LENS SHAPE	TERMINAL TYPE	SPECIAL FEATURES	DATA IN CAT. NO.
26-0410	C	11/16"	F	11/32"	* T-3 1/4 M.B.B. 2-55V	Stovepipe	Solder	Screw-in cap	L-161
26-0428	C	11/16"	F	11/16"	T-2 T.S.B. 6-60V	Stovepipe	Solder	Screw-in cap	L-161
26-1310	C	11/16"	F	11/32"	* T-3 1/4 M.B.B. 2-55V	Stovepipe	Screw	Screw-in cap	L-161
26-1328	C	11/16"	F	11/16"	T-2 T.S.B. 6-60V	Stovepipe	Screw	Screw-in cap	L-161
26-5710	C	11/16"	F	11/32"	* T-3 1/4 M.B.B. 2-55V	Stovepipe	Quick Connect	Screw-in cap	L-161
33-0428	D	9/16"	B	21/32"	T-2 T.S.B. 6-60V	Flat	Solder	Friction-fit cap	L-161
33-1328	D	9/16"	B	21/32"	T-2 T.S.B. 6-60V	Flat	Screw	Friction-fit cap	L-161
37-0410	E	9/16"	B	3/8"	* T-3 1/4 M.B.B. 2-55V	Flat	Solder	Screw-on cap	L-161
37-0428	E	9/16"	B	21/32"	T-2 T.S.B. 6-60V	Convex, Faceted	Solder	Screw-on cap	L-161
37-1310	E	9/16"	B	3/8"	* T-3 1/4 M.B.B. 2-55V	Flat	Screw	Screw-on cap	L-161
37-1328	E	9/16"	B	21/32"	T-2 T.S.B. 6-60V	Convex, Faceted	Screw	Screw-on cap	L-161
52-0410	F	11/16"	F	13/32"	* T-3 1/4 M.B.B. 2-55V	Stovepipe	Solder	Screw-in cap	L-161
52-1059	F	11/16"	F	5/16"	T-2 T.S.B. 6-120V	Stovepipe	Amp connector	Screw-in cap	L-161
52-1310	F	11/16"	F	13/32"	* T-3 1/4 M.B.B. 2-55V	Stovepipe	Screw	Screw-in cap	L-161
52-5710	F	11/16"	F	13/32"	* T-3 1/4 M.B.B. 2-55V	Stovepipe	Quick Connect	Screw-in cap	L-161
55-0428	G	11/16"	F	5/8"	T-2 T.S.B. 6-60V	Flat	Solder	Friction-fit cap	L-161
55-1328	G	11/16"	F	5/8"	T-2 T.S.B. 6-60V	Flat	Screw	Friction-fit cap	L-161

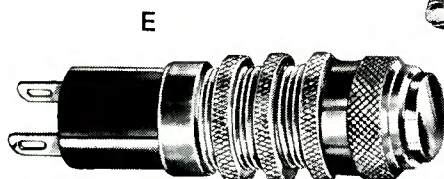

E

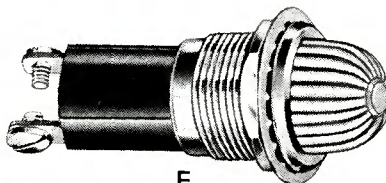

F

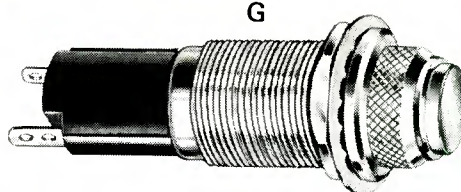

G

See Note 1 on page 2.



H

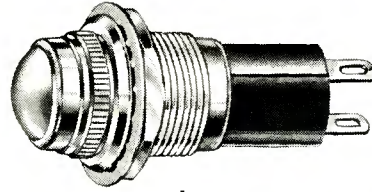

J

SERIES	ILLUS.	MTG. CLEAR. HOLE	PANEL INSERTION (F) FRONT (B) BACK	MAX. PANEL THICKNS.	LAMP ACCOMMO. & V. RANGE	LENS SHAPE	TERMINAL TYPE	SPECIAL FEATURES	DATA IN CAT. NO.
70-0410	H	9/16"	B	3/8"	* T-3 1/4 M.B.B. 2-55V	Stovepipe	Solder	Screw-on cap	L-161
70-0428	H	9/16"	B	3/8"	T-2 T.S.B. 6-60V	Stovepipe	Solder	Screw-on cap	L-161
70-1310	H	9/16"	B	3/8"	* T-3 1/4 M.B.B. 2-55V	Stovepipe	Screw	Screw-on cap	L-161
70-1328	H	9/16"	B	3/8"	T-2 T.S.B. 6-60V	Stovepipe	Screw	Screw-on cap	L-161
81-0410	J	11/16"	F	13/32"	* T-3 1/4 M.B.B. 2-55V	Convex, Flat	Solder	Screw-in cap; also see 373-0410	L-161
81-0428	J	11/16"	F	11/16"	T-2 T.S.B. 6-60V	Convex, Faceted	Solder	Screw-in cap	L-161
81-1059	J	11/16"	F	5/16"	T-2 T.S.B. 6-120V	Convex, Faceted	Amp connector	Screw-in cap	L-161
81-1310	J	11/16"	F	11/32"	* T-3 1/4 M.B.B. 2-55V	Convex	Screw	Screw-in cap	L-161
81-5710	J	11/16"	F	13/32"	* T-3 1/4 M.B.B. 2-55V	Convex	Quick Connect	Screw-in cap	L-161
85-0410	K	11/16"	F	11/32"	* T-3 1/4 M.B.B. 2-55V	Dome	Solder	Screw-on cap	L-161
85-1310	K	11/16"	F	11/32"	* T-3 1/4 M.B.B. 2-55V	Dome	Screw	Screw-on cap	L-161
85-5710	K	11/16"	F	11/32"	* T-3 1/4 M.B.B. 2-55V	Dome	Quick Connect	Screw-on cap	L-161
89-0410	L	11/16"	F	9/32"	* T-3 1/4 M.B.B. 2-55V	-----	Solder	Light Shield cap	L-161
89-1310	L	11/16"	F	9/32"	* T-3 1/4 M.B.B. 2-55V	-----	Screw	Light Shield cap	L-161
90-0410	L	11/16"	F	9/32"	* T-3 1/4 M.B.B. 2-55V	-----	Solder	Light Shield cap	L-161
90-1310	L	11/16"	F	9/32"	* T-3 1/4 M.B.B. 2-55V	-----	Screw	Light Shield cap	L-161

See Note 1 on page 2.

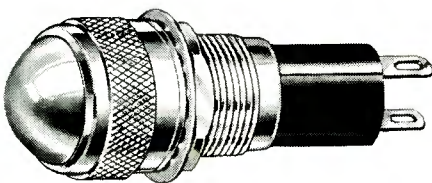

K

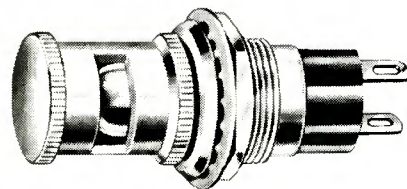

L

* See discussion of Incandescent Indicator Lights on page 25

See Note 1 on page 2.

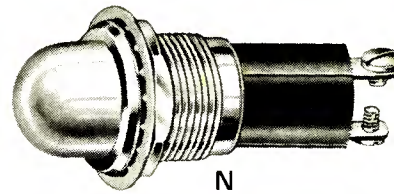
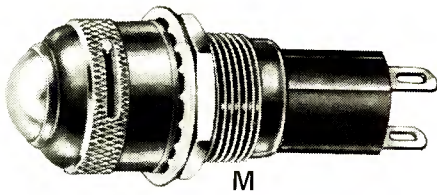

SERIES	ILLUS.	MTG. CLEAR. HOLE	PANEL INSERTION (F) FRONT (B) BACK	MAX. PANEL THICKNS.	LAMP ACCOMMO. & V. RANGE	LENS SHAPE	TERMINAL TYPE	SPECIAL FEATURES	DATA IN CAT. NO.
93-0410	M	11/16"	F	3/8"	* T-3 1/4 M.B.B. 2-55V	Convex	Solder	Screw-on cap; Dimmer-Polaroid	L-161
93-1310	M	11/16"	F	3/8"	* T-3 1/4 M.B.B. 2-55V	Convex	Screw	Screw-on cap; Dimmer-Polaroid	L-161
93-2210	M	11/16"	F	11/32"	* T-3 1/4 M.B.B. 2-55V	Convex	Solder	Screw-on cap; Dimmer-Polaroid	L-161
93-5910	M	11/16"	F	11/32"	* T-3 1/4 M.B.B. 2-55V	Convex	Screw	Screw-on cap; Dimmer-Polaroid	L-161
95-0410	N	11/16"	F	13/32"	* T-3 1/4 M.B.B. 2-55V	Stovepipe	Solder	Screw-in cap	L-161
95-0428	N	11/16"	F	11/16"	T-2 T.S.B. 6-60V	Stovepipe	Solder	Screw-in cap	L-161
95-1059	N	11/16"	F	5/16"	T-2 T.S.B. 6-120V	Stovepipe	Solder	Screw-in cap	L-161
95-1310	N	11/16"	F	13/32"	* T-3 1/4 M.B.B. 2-55V	Stovepipe	Screw	Screw-in cap	L-161
95-1328	N	11/16"	F	11/16"	T-2 T.S.B. 6-60V	Stovepipe	Screw	Screw-in cap	L-161
95-5710	N	11/16"	F	13/32"	* T-3 1/4 M.B.B. 2-55V	Stovepipe	Quick Connect	Screw-in cap	L-161
105-4428	O	7/16"	B	5/16"	T-2 T.S.B. 6-60V	Plano-Convex	Solder	Friction-fit cap; Slotted flange	L-161
126-4428	O	7/16"	B	5/16"	T-2 T.S.B. 6-60V	Flat	Solder	Friction-fit cap; Slotted flange	L-161
129-4428	O	7/16"	B	5/16"	T-2 T.S.B. 6-60V	Convex	Solder	Friction-fit cap; Slotted flange	L-161
132-0410	P	11/16"	F	13/32"	* T-3 1/4 M.B.B. 2-55V	Stovepipe	Solder	Screw-in cap	L-161
132-1310	P	11/16"	F	13/32"	* T-3 1/4 M.B.B. 2-55V	Stovepipe	Screw	Screw-in cap	L-161
132-5710	P	11/16"	F	13/32"	* T-3 1/4 M.B.B. 2-55V	Stovepipe	Quick Connect	Screw-in cap	L-161

See Note 1 on page 2.



O

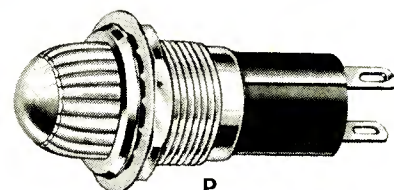

P

See Note 1 on page 2.

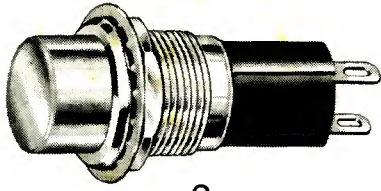

Q

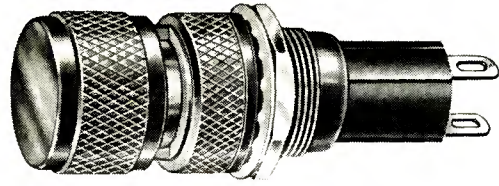

R

SERIES	ILLUS.	MTG. CLEAR. HOLE	PANEL INSERTION (F) FRONT (B) BACK	MAX. PANEL THICKNS.	LAMP ACCOMMO. & V. RANGE	LENS SHAPE	TERMINAL TYPE	SPECIAL FEATURES	DATA IN CAT. NO.
135-0410	Q	11/16"	F	13/32"	*T-3 1/4 M.B.B. 2-55V	Cylindrical	Solder	Screw-in cap	L-161
135-0428	Q	11/16"	F	11/16"	T-2 T.S.B. 6-60V	Cylindrical	Solder	Screw-in cap	L-161
135-1059	Q	11/16"	F	5/16"	T-2 T.S.B. 6-120V	Cylindrical	Amp Connector	Screw-in cap	L-161
135-1310	Q	11/16"	F	13/32"	*T-3 1/4 M.B.B. 2-55V	Cylindrical	Screw	Screw-in cap	L-161
135-1328	Q	11/16"	F	11/16"	T-2 T.S.B. 6-60V	Cylindrical	Screw	Screw-in cap	L-161
135-5710	Q	11/16"	F	13/32"	*T-3 1/4 M.B.B. 2-55V	Cylindrical	Quick Connect	Screw-in cap	L-161
156-0410	R	11/16"	F	11/16"	*T-3 1/4 M.B.B. 2-55V	0" to 1/4" x 3/8"	Solder	Variable Light Shield cap	L-161
156-1310	R	11/16"	F	11/16"	*T-3 1/4 M.B.B. 2-55V	0" to 1/4" x 3/8"	Screw	Variable Light Shield cap	L-161
169-0410	S	11/16"	F	11/32"	*T-3 1/4 M.B.B. 2-55V	Stovepipe	Solder	Screw-on cap; also meets MIL-L-3661B. See 377-0410.	L-161
169-1310	S	11/16"	F	11/32"	*T-3 1/4 M.B.B. 2-55V	Stovepipe	Screw	Screw-on cap	L-161
169-5710	S	11/16"	F	11/32"	*T-3 1/4 M.B.B. 2-55V	Stovepipe	Quick Connect	Screw-on cap	L-161
203-0410	T †	11/16"	F	11/32"	*T-3 1/4 M.B.B. 2-55V	Convex	Solder	Screw-in cap; Dimmer-Mechanical	L-161
203-1310	T †	11/16"	F	11/32"	*T-3 1/4 M.B.B. 2-55V	Convex	Screw	Screw-in cap; Dimmer-Mechanical	L-161
203-2210	T †	11/16"	F	1/2"	*T-3 1/4 M.B.B. 2-55V	Convex	Solder	Screw-in cap; Dimmer-Mechanical	L-161
203-5910	T †	11/16"	F	1/2"	*T-3 1/4 M.B.B. 2-55V	Convex	Screw	Screw-in cap; Dimmer-Mechanical	L-161

See Note 1 on page 2.

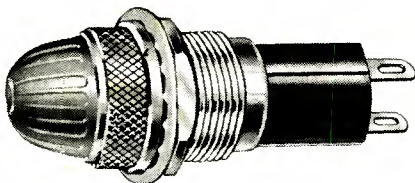

S

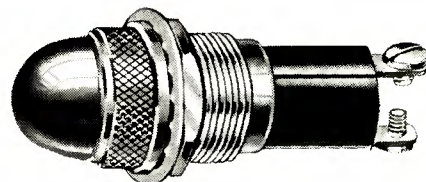

S

† See illustration T on page 30

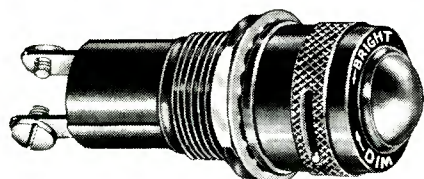

T

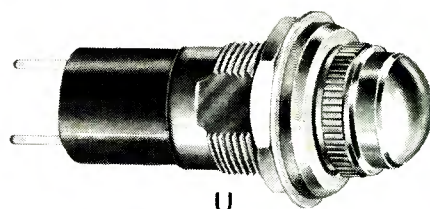

U

SERIES	ILLUS.	MTG. CLEAR. HOLE	PANEL INSERTION (F) FRONT (B) BACK	MAX. PANEL THICKNS.	LAMP ACCOMMO. & V. RANGE	LENS SHAPE	TERMINAL TYPE	SPECIAL FEATURES	DATA IN CAT. NO.
204-0410	T	11/16"	F	11/32"	* T-3 1/4 M.B.B. 2-55V	Convex	Solder	Screw-in cap; Dimmer-Mechanical	L-161
204-1310	T	11/16"	F	11/32"	* T-3 1/4 M.B.B. 2-55V	Convex	Screw	Screw-in cap; Dimmer-Mechanical	L-161
204-2210	T	11/16"	F	1/2"	* T-3 1/4 M.B.B. 2-55V	Convex	Solder	Screw-in cap; Dimmer-Mechanical	L-161
204-5910	T	11/16"	F	1/2"	* T-3 1/4 M.B.B. 2-55V	Convex	Screw	Screw-in cap; Dimmer-Mechanical	L-161
207-0410	T	11/16"	F	11/32"	* T-3 1/4 M.B.B. 2-55V	Convex	Solder	Screw-on cap; Dimmer-Mechanical	L-161
207-1310	T	11/16"	F	11/32"	* T-3 1/4 M.B.B. 2-55V	Convex	Screw	Screw-on cap; Dimmer-Mechanical	L-161
207-2210	T	11/16"	F	3/8"	* T-3 1/4 M.B.B. 2-55V	Convex	Solder	Screw-on cap; Dimmer-Mechanical	L-161
207-5910	T	11/16"	F	3/8"	* T-3 1/4 M.B.B. 2-55V	Convex	Screw	Screw-on cap; Dimmer-Mechanical	L-161
208-0410	T	11/16"	F	11/32"	* T-3 1/4 M.B.B. 2-55V	Convex	Solder	Screw-on cap; Dimmer-Mechanical	L-161
208-1310	T	11/16"	F	11/32"	* T-3 1/4 M.B.B. 2-55V	Convex	Screw	Screw-on cap; Dimmer-Mechanical	L-161
208-2210	T	11/16"	F	3/8"	* T-3 1/4 M.B.B. 2-55V	Convex	Solder	Screw-on cap; Dimmer-Mechanical	L-161
208-5910	T	11/16"	F	3/8"	* T-3 1/4 M.B.B. 2-55V	Convex	Screw	Screw-on cap; Dimmer-Mechanical	L-161
220-4428	O†	7/16"	B	5/16"	T-2 T.S.B. 6-60V	Convex	Solder	See 105-4428 series	L-161
221-0410	S†	11/16"	F	11/32"	* T-3 1/4 M.B.B. 2-55V	Stovepipe	Solder	RFI ; Screw-in cap	_____
222-0410	J†	11/16"	F	11/32"	* T-3 1/4 M.B.B. 2-55V	Convex	Solder	RFI ; Screw-in cap	_____
373-0410	U	11/16"	F	13/32"	* T-3 1/4 M.B.B. 2-55V	Convex	Solder	Screw-in cap; meets MIL-L-3661B	CR680 L-161
375-0410	V	11/16"	F	11/32"	* T-3 1/4 M.B.B. 2-55V	Convex	Solder	Screw-in cap; Dimmer-Mechanical Meets MIL-L-3661B	CR680 L-161
376-0410	V	11/16"	F	11/32"	* T-3 1/4 M.B.B. 2-55V	Convex	Solder	Screw-in cap; Dimmer-Mechanical Meets MIL-L-3661B	CR680 L-161
377-0410	W	11/16"	F	11/32"	* T-3 1/4 M.B.B. 2-55V	Stovepipe	Solder	Screw-on cap; Meets MIL-L-3661B	CR680 L-161

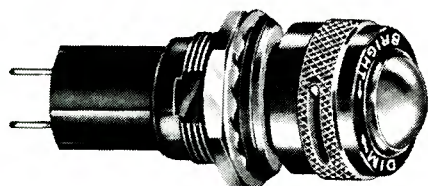

V

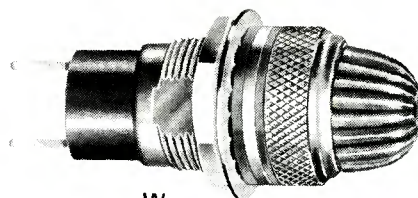

W

See Note 1 on page 2.

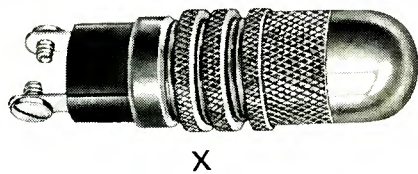

X

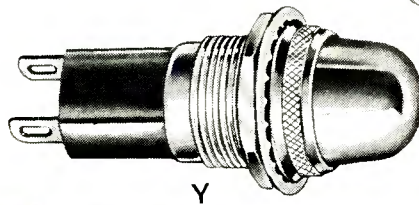

Y

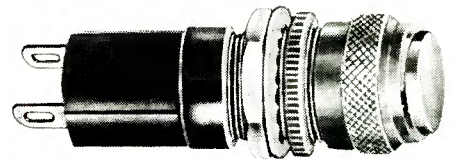

Z

SERIES	ILLUS.	MTG. CLEAR. HOLE	PANEL INSERTION (F) FRONT (B) BACK	MAX. PANEL THICKNS.	LAMP ACCOMMO. & V. RANGE	LENS SHAPE	TERMINAL TYPE	SPECIAL FEATURES	DATA IN CAT. NO.
NEON									
17-0408	X	9/16"	B	3/8"	B1A (NE-51)M.B.B. 105-125V AC-DC	Stovepipe	Solder	Screw-on cap	L-161
17-0463	X	9/16"	B	3/8"	B2A (NE-51H)M.B.B. 110-125V AC	Stovepipe	Solder	Screw-on cap	L-161
17-1308	X	9/16"	B	3/8"	B1A (NE-51)M.B.B. 105-125V AC-DC	Stovepipe	Screw	Screw-on cap	L-161
17-1363	X	9/16"	B	3/8"	B2A (NE-51H)M.B.B. 110-125V AC	Stovepipe	Screw	Screw-on cap	L-161
26-0408	Y	11/16"	F	3/8"	B1A (NE-51)M.B.B. 105-125V AC-DC	Stovepipe	Solder	Screw-in cap	L-161
26-0463	Y	11/16"	F	3/8"	B2A (NE-51H)M.B.B. 110-125V AC	Stovepipe	Solder	Screw-in cap	L-161
26-1308	Y	11/16"	F	3/8"	B1A (NE-51)M.B.B. 105-125V AC-DC	Stovepipe	Screw	Screw-in cap	L-161
26-1363	Y	11/16"	F	3/8"	B2A (NE-51H)M.B.B. 110-125V AC	Stovepipe	Screw	Screw-in cap	L-161
26-5708	Y	11/16"	F	3/8"	B1A (NE-51)M.B.B. 105-125V AC-DC	Stovepipe	Quick Connect	Screw-in cap	L-161
26-5763	Y	11/16"	F	3/8"	B2A (NE-51H)M.B.B. 110-125V AC	Stovepipe	Quick Connect	Screw-in cap	L-161
26-5863	Y	11/16"	F	3/8"	B2A (NE-51H)M.B.B. 210-250V AC-DC	Stovepipe	Quick Connect	Screw-in cap	L-161
26-9363	Y	11/16"	F	3/8"	B2A (NE-51H)M.B.B. 210-250V AC-DC	Stovepipe	Screw	Screw-in cap	L-161
26-9463	Y	11/16"	F	3/8"	B2A (NE-51H)M.B.B. 210-250V AC-DC	Stovepipe	Solder	Screw-in cap	L-161
37-0408	Z	9/16"	B	3/8"	B1A (NE-51)M.B.B. 105-125V AC-DC	Flat	Solder	Screw-on cap	L-161
37-0463	Z	9/16"	B	3/8"	B2A (NE-51H)M.B.B. 110-125V AC	Flat	Solder	Screw-on cap	L-161
37-1308	Z	9/16"	B	3/8"	B1A (NE-51)M.B.B. 105-125V AC-DC	Flat	Screw	Screw-on cap	L-161
37-1363	Z	9/16"	B	3/8"	B2A (NE-51H)M.B.B. 110-125V AC	Flat	Screw	Screw-on cap	L-161

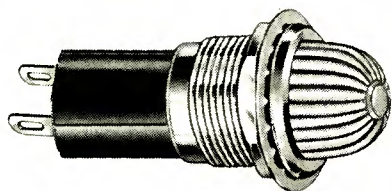

AA

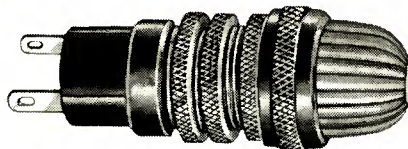

BB

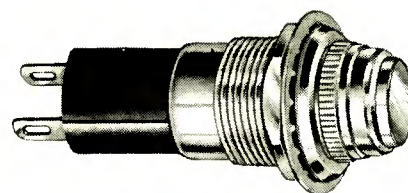

CC

SERIES	ILLUS.	MTG. CLEAR. HOLE	PANEL INSERTION (F) FRONT (B) BACK	MAX. PANEL THICKNS.	LAMP ACCOMMO. & V. RANGE	LENS SHAPE	TERMINAL TYPE	SPECIAL FEATURES	DATA IN CAT. NO.
52-0408	AA	11/16"	F	13/32"	B1A (NE-51)M.B.B. 105-125V AC-DC	Stovepipe	Solder	Screw-in cap	L-161
52-0463	AA	11/16"	F	13/32"	B2A (NE-51H)M.B.B. 110-125V AC	Stovepipe	Solder	Screw-in cap	L-161
52-1308	AA	11/16"	F	13/32"	B1A (NE-51)M.B.B. 105-125V AC-DC	Stovepipe	Screw	Screw-in cap	L-161
52-1363	AA	11/16"	F	13/32"	B2A (NE-51H)M.B.B. 110-125V AC	Stovepipe	Screw	Screw-in cap	L-161
52-5708	AA	11/16"	F	13/32"	B1A (NE-51)M.B.B. 105-125V AC-DC	Stovepipe	Quick Connect	Screw-in cap	L-161
52-5763	AA	11/16"	F	13/32"	B2A (NE-51H)M.B.B. 110-125V AC	Stovepipe	Quick Connect	Screw-in cap	L-161
52-5863	AA	11/16"	F	13/32"	B2A (NE-51H)M.B.B. 210-250V AC-DC	Stovepipe	Quick Connect	Screw-in cap	L-161
52-9363	AA	11/16"	F	13/32"	B2A (NE-51H)M.B.B. 210-250V AC-DC	Stovepipe	Screw	Screw-in cap	L-161
52-9463	AA	11/16"	F	13/32"	B2A (NE-51H)M.B.B. 210-250V AC-DC	Stovepipe	Solder	Screw-in cap	L-161
70-0408	BB	9/16"	B	3/8"	B1A (NE-51)M.B.B. 105-125V AC-DC	Stovepipe	Solder	Screw-on cap	L-161
70-0463	BB	9/16"	B	3/8"	B2A (NE-51H)M.B.B. 110-125V AC	Stovepipe	Solder	Screw-on cap	L-161
70-1308	BB	9/16"	B	3/8"	B1A (NE-51)M.B.B. 105-125V AC-DC	Stovepipe	Screw	Screw-on cap	L-161
70-1363	BB	9/16"	B	3/8"	B2A (NE-51H)M.B.B. 110-125V AC	Stovepipe	Screw	Screw-on cap	L-161
81-0408	CC	11/16"	F	13/32"	B1A (NE-51)M.B.B. 105-125V AC-DC	Flat	Solder	Screw-in cap; also see 373-0408	L-161
81-0463	CC	11/16"	F	13/32"	B2A (NE-51H)M.B.B. 110-125V AC	Flat	Solder	Screw-in cap; also see 373-0463	L-161
81-1308	CC	11/16"	F	13/32"	B1A (NE-51)M.B.B. 105-125V AC-DC	Flat	Screw	Screw-in cap	L-161
81-1363	CC	11/16"	F	13/32"	B2A (NE-51H)M.B.B. 110-125V AC	Flat	Screw	Screw-in cap	L-161
81-5708	CC	11/16"	F	13/32"	B1A (NE-51)M.B.B. 105-125V AC-DC	Flat	Quick Connect	Screw-in cap	L-161

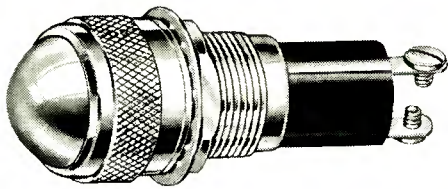

DD

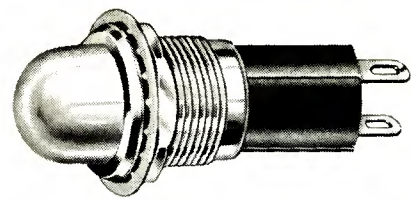

EE

SERIES	ILLUS.	MTG. CLEAR. HOLE	PANEL INSERTION (F) FRONT (B) BACK	MAX. PANEL THICKNS.	LAMP ACCOMMO. & V. RANGE	LENS SHAPE	TERMINAL TYPE	SPECIAL FEATURES	DATA IN CAT. NO.
81-5763	CC†	11/16"	F	13/32"	B2A (NE-51H)M.B.B. 110-125V AC	Flat	Quick Connect	Screw-in cap	L-161
81-5863	CC†	11/16"	F	13/32"	B2A (NE-51H)M.B.B. 210-250V AC-DC	Flat	Quick Connect	Screw-in cap	L-161
81-9363	CC†	11/16"	F	13/32"	B2A (NE-51H)M.B.B. 210-250V AC-DC	Flat	Screw	Screw-in cap	L-161
81-9463	CC†	11/16"	F	13/32"	B2A (NE-51H)M.B.B. 210-250V AC-DC	Flat	Solder	Screw-in cap	L-161
85-0408	DD	11/16"	F	11/32"	B1A (NE-51)M.B.B. 105-125V AC-DC	Dome	Solder	Screw-on cap	L-161
85-0463	DD	11/16"	F	11/32"	B2A (NE-51H)M.B.B. 110-125V AC	Dome	Solder	Screw-on cap	L-161
85-1308	DD	11/16"	F	11/32"	B1A (NE-51)M.B.B. 105-125V AC-DC	Dome	Screw	Screw-on cap	L-161
85-1363	DD	11/16"	F	11/32"	B2A (NE-51H)M.B.B. 110-125V AC	Dome	Screw	Screw-on cap	L-161
85-5708	DD	11/16"	F	11/32"	B1A (NE-51)M.B.B. 105-125V AC-DC	Dome	Quick Connect	Screw-on cap	L-161
85-5763	DD	11/16"	F	11/32"	B2A (NE-51H)M.B.B. 110-125V AC	Dome	Quick Connect	Screw-on cap	L-161
85-5863	DD	11/16"	F	11/32"	B2A (NE-51H)M.B.B. 210-250V AC-DC	Dome	Quick Connect	Screw-on cap	L-161
85-9363	DD	11/16"	F	9/32"	B2A (NE-51H)M.B.B. 210-250V AC-DC	Dome	Screw	Screw-on cap	L-161
85-9463	DD	11/16"	F	11/32"	B2A (NE-51H)M.B.B. 210-250V AC-DC	Dome	Solder	Screw-on cap	L-161
95-0408	EE	11/16"	F	13/32"	B1A (NE-51)M.B.B. 105-125V AC-DC	Stovepipe	Solder	Screw-in cap	L-161
95-0463	EE	11/16"	F	13/32"	B2A (NE-51H)M.B.B. 110-125V AC	Stovepipe	Solder	Screw-in cap	L-161
95-1308	EE	11/16"	F	13/32"	B1A (NE-51)M.B.B. 105-125V AC-DC	Stovepipe	Screw	Screw-in cap	L-161
95-1363	EE	11/16"	F	13/32"	B2A (NE-51H)M.B.B. 110-125V AC	Stovepipe	Screw	Screw-in cap	L-161
95-5708	EE	11/16"	F	13/32"	B1A (NE-51)M.B.B. 105-125V AC-DC	Stovepipe	Quick Connect	Screw-in cap	L-161

† See illustration CC on page 32

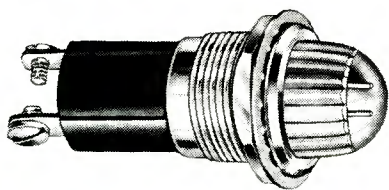

FF

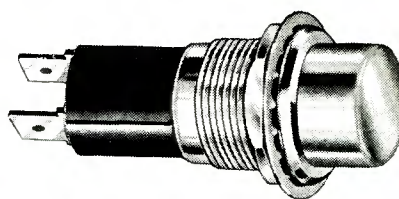

GG

SERIES	ILLUS.	MTG. CLEAR. HOLE	PANEL INSERTION (F) FRONT (B) BACK	MAX. PANEL THICKNS.	LAMP ACCOMMO. & V. RANGE	LENS SHAPE	TERMINAL TYPE	SPECIAL FEATURES	DATA IN CAT. NO.
95-5763	EE†	11/16"	F	13/32"	B2A (NE-51H)M.B.B. 110-125V AC	Stovepipe	Quick Connect	Screw-in cap	L-161
95-5863	EE†	11/16"	F	13/32"	B2A (NE-51H)M.B.B. 210-250V AC-DC	Stovepipe	Quick Connect	Screw-in cap	L-161
95-9363	EE†	11/16"	F	13/32"	B2A (NE-51H)M.B.B. 210-250V AC-DC	Stovepipe	Screw	Screw-in cap	L-161
95-9463	EE†	11/16"	F	13/32"	B2A (NE-51H)M.B.B. 210-250V AC-DC	Stovepipe	Solder	Screw-in cap	L-161
132-0408	FF	11/16"	F	13/32"	B1A (NE-51)M.B.B. 105-125V AC-DC	Stovepipe	Solder	Screw-in cap	L-161
132-0463	FF	11/16"	F	13/32"	B2A (NE-51H)M.B.B. 110-125V AC	Stovepipe	Solder	Screw-in cap	L-161
132-1308	FF	11/16"	F	13/32"	B1A (NE-51)M.B.B. 105-125V AC-DC	Stovepipe	Screw	Screw-in cap	L-161
132-1363	FF	11/16"	F	13/32"	B2A (NE-51H)M.B.B. 110-125V AC	Stovepipe	Screw	Screw-in cap	L-161
132-5708	FF	11/16"	F	13/32"	B1A (NE-51)M.B.B. 105-125V AC-DC	Stovepipe	Quick Connect	Screw-in cap	L-161
132-5763	FF	11/16"	F	13/32"	B2A (NE-51H)M.B.B. 110-125V AC	Stovepipe	Quick Connect	Screw-in cap	L-161
132-5863	FF	11/16"	F	13/32"	B2A (NE-51H)M.B.B. 210-250V AC-DC	Stovepipe	Quick Connect	Screw-in cap	L-161
132-9363	FF	11/16"	F	13/32"	B2A (NE-51H)M.B.B. 210-250V AC-DC	Stovepipe	Screw	Screw-in cap	L-161
132-9463	FF	11/16"	F	13/32"	B2A (NE-51H)M.B.B. 210-250V AC-DC	Stovepipe	Solder	Screw-in cap	L-161
135-0408	GG	11/16"	F	13/32"	B1A (NE-51)M.B.B. 105-125V AC-DC	Cylindrical	Solder	Screw-in cap	L-161
135-0463	GG	11/16"	F	13/32"	B2A (NE-51H)M.B.B. 110-125V AC	Cylindrical	Solder	Screw-in cap	L-161
135-1308	GG	11/16"	F	13/32"	B1A (NE-51)M.B.B. 105-125V AC-DC	Cylindrical	Screw	Screw-in cap	L-161
135-1363	GG	11/16"	F	13/32"	B2A (NE-51H)M.B.B. 110-125V AC	Cylindrical	Screw	Screw-in cap	L-161
135-5708	GG	11/16"	F	13/32"	B1A (NE-51)M.B.B. 105-125V AC-DC	Cylindrical	Quick Connect	Screw-in cap	L-161

† See illustration EE on page 33

See Note 1 on page 2.

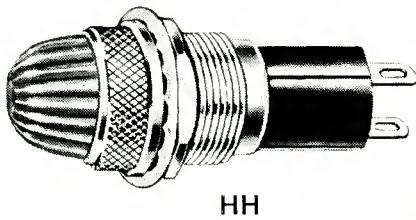

HH

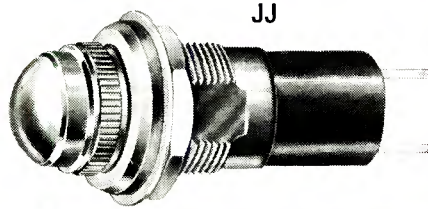

JJ

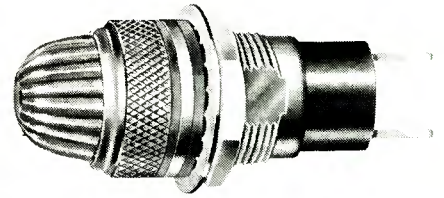

KK

SERIES	ILLUS.	MTG. CLEAR. HOLE	PANEL INSERTION (F) FRONT (B) BACK	MAX. PANEL THICKNS.	LAMP ACCOMMO. & V. RANGE	LENS SHAPE	TERMINAL TYPE	SPECIAL FEATURES	DATA IN CAT. NO.
135-5763	GG [†]	11/16"	F	13/32"	B2A (NE-51H)M.B.B. 110-125V AC	Cylindrical	Quick Connect	Screw-in cap	L-161
135-5863	GG [†]	11/16"	F	13/32"	B2A (NE-51H)M.B.B. 210-250V AC-DC	Cylindrical	Quick Connect	Screw-in cap	L-161
135-9363	GG [†]	11/16"	F	13/32"	B2A (NE-51H)M.B.B. 210-250V AC-DC	Cylindrical	Screw	Screw-in cap	L-161
135-9463	GG [†]	11/16"	F	13/32"	B2A (NE-51H)M.B.B. 210-250V AC-DC	Cylindrical	Solder	Screw-in cap	L-161
169-0408	HH	11/16"	F	11/32"	B1A (NE-51)M.B.B. 105-125V AC-DC	Stovepipe	Solder	Screw-on cap; also see 377-0408	L-161
169-0463	HH	11/16"	F	11/32"	B2A (NE-51H)M.B.B. 110-125V AC	Stovepipe	Solder	Screw-on cap; also see 377-0463	L-161
169-1308	HH	11/16"	F	11/32"	B1A (NE-51)M.B.B. 105-125V AC-DC	Stovepipe	Screw	Screw-on cap	L-161
169-1363	HH	11/16"	F	11/32"	B2A (NE-51H)M.B.B. 110-125V AC	Stovepipe	Screw	Screw-on cap	L-161
169-5708	HH	11/16"	F	11/32"	B1A (NE-51)M.B.B. 105-125V AC-DC	Stovepipe	Quick Connect	Screw-on cap	L-161
169-5763	HH	11/16"	F	11/32"	B2A (NE-51H)M.B.B. 110-125V AC	Stovepipe	Quick Connect	Screw-on cap	L-161
169-5863	HH	11/16"	F	11/32"	B2A (NE-51H)M.B.B. 210-250V AC-DC	Stovepipe	Quick	Screw-on cap	L-161
169-9363	HH	11/16"	F	11/32"	B2A (NE-51H)M.B.B. 210-250V AC-DC	Stovepipe	Screw	Screw-on cap	L-161
169-9463	HH	11/16"	F	11/32"	B2A (NE-51H)M.B.B. 210-250V AC-DC	Stovepipe	Solder	Screw-on cap	L-161
373-0408	JJ	11/16"	F	13/32"	B1A (NE-51)M.B.B. 105-125V AC-DC	Convex	Solder	Screw-in cap; meets MIL-L-3661B	CR680 L-161
373-0463	JJ	11/16"	F	13/32"	B2A (NE-51H)M.B.B. 110-125V AC	Convex	Solder	Screw-in cap; meets MIL-L-3661B	CR680 L-161
375-0408	V	11/16"	F	11/32"	B1A (NE-51)M.B.B. 105-125V AC-DC	Convex	Solder	Screw-in cap; Dimmer-Mechanical meets MIL-L-3661B	CR680 L-161
375-0463	V	11/16"	F	11/32"	B2A (NE-51H)M.B.B. 110-125V AC	Convex	Solder	Screw-in cap; Dimmer-Mechanical meets MIL-L-3661B	CR680 L-161
376-0408	V	11/16"	F	11/32"	B1A (NE-51)M.B.B. 105-125V AC-DC	Convex	Solder	Screw-in cap; Dimmer-Mechanical meets MIL-L-3661B	CR680 L-161
376-0463	V	11/16"	F	11/32"	B2A (NE-51H)M.B.B. 110-125V AC	Convex	Solder	Screw-in cap; Dimmer-Mechanical meets MIL-L-3661B	CR680 L-161
377-0408	KK	11/16"	F	11/32"	B1A (NE-51)M.B.B. 105-125V AC-DC	Stovepipe	Solder	Screw-on cap; meets MIL-L-3661B	CR680 L-161
377-0463	KK	11/16"	F	11/32"	B2A (NE-51H)M.B.B. 110-125V AC	Stovepipe	Solder	Screw-on cap; meets MIL-L-3661B	CR680 L-161

[†] See illustration GG on page 34

LARGE INDICATOR LIGHTS

The indicator lights listed in this section mount in 1" clearance hole.

Incandescent Indicator Lights may accommodate the following lamps: T-3¼ bulb with miniature bayonet base (listed as T-3¼ M.B.B.) — from 2-55V; T-3 bulb with miniature bayonet base, from 6-120V (consult factory); S-6 bulb with candelabra screw base (listed as S-6 C.S.B.) or double contact bayonet base (listed as S-6 D.C.B.B.) — from 6-250V; or lastly, G-6 bulb with double contact bayonet base (listed as G-6 D.C.B.B.) — from 6-32V.

Neon Indicator Lights accommodate either B1A (NE-51) standard brightness (for 105-125V AC-DC; or B2A (NE-51H) high brightness (for 110-125V AC or 210-250V AC-DC) glow lamps with miniature bayonet base, and are listed as B1A (NE-51) M.B.B. or B2A (NE-51H) M.B.B. respectively. Neon lamps require a resistor (or other ballast device) to limit the lamp current. Dialco makes the required resistor an integral part (built-in — a patented Dialight feature — U. S. Pat. No. 2,421,321) of these indicators.

Other neon indicator lights listed in this section accommodate T-4½ bulbs— with candelabra screw base (listed as T-4½ C.S.B.) for 125 or 250 volts. The lamp base contains the required resistor.

INCANDESCENT

SERIES	ILLUS.	MTG. CLEAR. HOLE	PANEL INSERTION (F) FRONT (B) BACK	MAX. PANEL THICKNS.	LAMP ACCOMMO. & V. RANGE	LENS SHAPE	TERMINAL TYPE	SPECIAL FEATURES	DATA IN CAT. NO.
19-0410	A	1"	F	1/4"	T-3 1/4 M.B.B. 2-55V	Large Torpedo	Solder	1-1/4" dia. lens	L-161
19-0901	A	1"	F	1/2"	S-6 C.S.B. 6-250V	Large Torpedo	Side Screw	1-1/4" dia. lens	L-161
19-1310	A	1"	F	1/4"	T-3 1/4 M.B.B. 2-55V	Large Torpedo	Screw	1-1/4" dia. lens	L-161
19-3101	A	1"	F	1/2"	S-6 C.S.B. 6-250V	Large Torpedo	Protruding Screw	1-1/4" dia. lens	L-161
19-3202	A	1"	F	1/2"	S-6 D.C.B.B. 6-250V	Large Torpedo	Fixed Screw	1-1/4" dia. lens	L-161
19-3204	A	1"	F	1/4"	G-6 D.C.B.B. 6-32V	Large Torpedo	Fixed Screw	1-1/4" dia. lens	L-161
19-3402	A	1"	F	1/2"	S-6 D.C.B.B. 6-250V	Large Torpedo	Fixed Solder	1-1/4" dia. lens	L-161
19-3404	A	1"	F	1/4"	G-6 D.C.B.B. 6-32V	Large Torpedo	Fixed Solder	1-1/4" dia. lens	L-161
19-4001	A	1"	F	1/2"	S-6 C.S.B. 6-250V	Large Torpedo	Solder	1-1/4" dia. lens	L-161
19-6602	A	1"	F	1/2"	S-6 D.C.B.B. 6-250V	Large Torpedo	Quick Connect	1-1/4" dia. lens	L-161
19-6604	A	1"	F	1/4"	G-6 D.C.B.B. 6-32V	Large Torpedo	Quick Connect	1-1/4" dia. lens	L-161

See Note 1 on page 2.

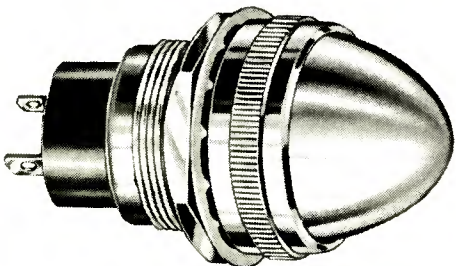

A

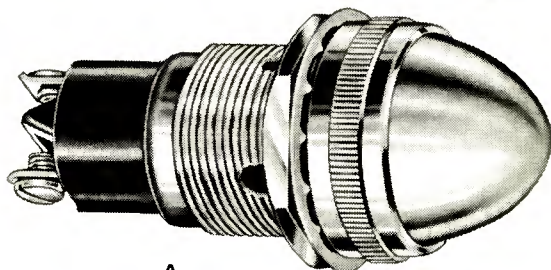

A

See Note 1 on page 2.

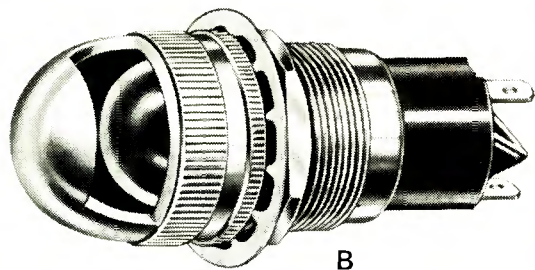

B

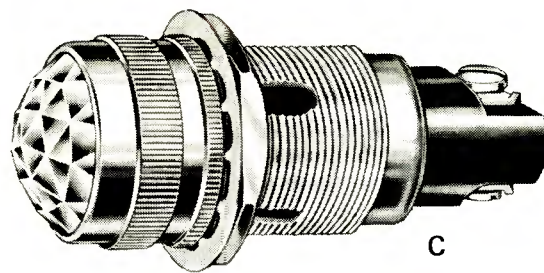

C

See page 35 for data on illustration C.

SERIES	ILLUS.	MTG. CLEAR. HOLE	PANEL INSERTION (F) FRONT (B) BACK	MAX. PANEL THICKNS.	LAMP ACCOMMO. & V. RANGE	LENS SHAPE	TERMINAL TYPE	SPECIAL FEATURES	DATA IN CAT. NO.
19-6701	A*	1"	F	1/2"	S-6 C.S.B. 6-250V	Large Torpedo	Quick Connect	1-1/4" dia. lens	L-161
▲ 31-									
47-3101	B	1"	F	7/16"	S-6 C.S.B. 6-250V	Dome, 3/8" X 1" opening	Protruding Screw	Light Shield Lens Cap	L-161
47-3202	B	1"	F	7/16"	S-6 D.C.B.B. 6-250V	Dome, 3/8" X 1" opening	Fixed Screw	Light Shield Lens Cap	L-161
47-3402	B	1"	F	7/16"	S-6 D.C.B.B. 6-250V	Dome, 3/8" X 1" opening	Fixed Solder	Light Shield Lens Cap	L-161
47-4001	B	1"	F	7/16"	S-6 C.S.B. 6-250V	Dome, 3/8" X 1" opening	Solder	Light Shield Lens Cap	L-161
47-6602	B	1"	F	7/16"	S-6 D.C.B.B. 6-250V	Dome, 3/8" X 1" opening	Quick Connect	Light Shield Lens Cap	L-161
47-6701	B	1"	F	7/16"	S-6 C.S.B. 6-250V	Dome, 3/8" X 1" opening	Quick Connect	Light Shield Lens Cap	L-161
49-3101	B	1"	F	7/16"	S-6 C.S.B. 6-250V	Dome, 1/4" X 1" opening	Protruding Screw	Light Shield Lens Cap	L-161
49-3202	B	1"	F	7/16"	S-6 D.C.B.B. 6-250V	Dome, 1/4" X 1" opening	Fixed Screw	Light Shield Lens Cap	L-161
49-3402	B	1"	F	7/16"	S-6 D.C.B.B. 6-250V	Dome, 1/4" X 1" opening	Fixed Solder	Light Shield Lens Cap	L-161
49-4001	B	1"	F	7/16"	S-6 C.S.B. 6-250V	Dome, 1/4" X 1" opening	Solder	Light Shield Lens Cap	L-161
49-6602	B	1"	F	7/16"	S-6 D.C.B.B. 6-250V	Dome, 1/4" X 1" opening	Quick Connect	Light Shield Lens Cap	L-161
49-6701	B	1"	F	7/16"	S-6 C.S.B. 6-250V	Dome, 1/4" X 1" opening	Quick Connect	Light Shield Lens Cap	L-161
50-3101	B	1"	F	7/16"	S-6 C.S.B. 6-250V	Dome, 1/8" X 1" opening	Protruding Screw	Light Shield Lens Cap	L-161
50-3202	B	1"	F	7/16"	S-6 D.C.B.B. 6-250V	Dome, 1/8" X 1" opening	Fixed Screw	Light Shield Lens Cap	L-161
50-3402	B	1"	F	7/16"	S-6 D.C.B.B. 6-250V	Dome, 1/8" X 1" opening	Fixed Solder	Light Shield Lens Cap	L-161
50-4001	B	1"	F	7/16"	S-6 C.S.B. 6-250V	Dome, 1/8" X 1" opening	Solder	Light Shield Lens Cap	L-161
50-6602	B	1"	F	7/16"	S-6 D.C.B.B. 6-250V	Dome, 1/8" X 1" opening	Quick Connect	Light Shield Lens Cap	L-161

* See illustration A on page 36

▲ See footnote on pages 38, 39, 41

See Note 1 on page 2.

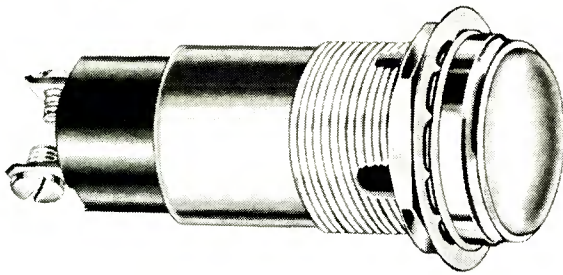

C

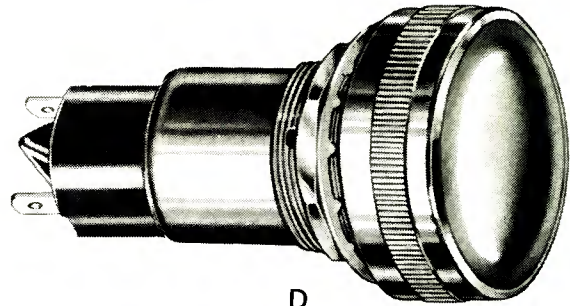

D

SERIES	ILLUS.	MTG. CLEAR. HOLE	PANEL INSERTION (F) FRONT (B) BACK	MAX. PANEL THICKNS.	LAMP ACCOMMO. & V. RANGE	LENS SHAPE	TERMINAL TYPE	SPECIAL FEATURES	DATA IN CAT. NO.
50-6701	B*	1"	F	7/16"	S-6 C.S.B. 6-250V	Dome, 1/8" X 1" opening	Quick Connect	Light Shield Lens Cap	L-161
▲ 51-0410	C	1"	F	7/16"	T-3 1/4 M.B.B. 2-55V	Flat, Convex, Faceted	Solder		L-161
▲ 51-0901	C	1"	F	3/4"	S-6 C.S.B. 6-250V	Flat, Convex, Faceted	Side Screw		L-161
▲ 51-1310	C	1"	F	7/16"	T-3 1/4 M.B.B. 2-55V	Flat, Convex, Faceted	Screw		L-161
▲ 51-3101	C	1"	F	5/8"	S-6 C.S.B. 6-250V	Flat, Convex Faceted	Protruding Screw		L-161
▲ 51-3202	C	1"	F	3/4"	S-6 D.C.B.B. 6-250V	Flat, Convex	Fixed Screw		L-161
▲ 51-3204	C	1"	F	7/16"	G-6 D.C.B.B. 6-32V	Convex	Fixed Screw		L-161
▲ 51-3402	C	1"	F	3/4"	S-6 D.C.B.B. 6-250V	Flat, Convex	Fixed Solder		L-161
▲ 51-3404	C	1"	F	7/16"	G-6 D.C.B.B. 6-32V	Convex	Fixed Solder		L-161
▲ 51-4001	C	1"	F	5/8"	S-6 C.S.B. 6-250V	Flat, Convex, Faceted	Solder		L-161
▲ 51-6602	C	1"	F	3/4"	S-6 D.C.B.B. 6-250V	Flat, Convex	Quick Connect		L-161
▲ 51-6604	C	1"	F	7/16"	G-6 D.C.B.B. 6-32V	Convex	Quick Connect		L-161
▲ 51-6701	C	1"	F	5/8"	S-6 C.S.B. 6-250V	Flat, Convex, Faceted	Quick Connect		L-161
61-0410	D	1"	F	1/2"	T-3 1/4 M.B.B. 2-55V	Large Convex	Solder	1-1/2" dia. lens	L-161
61-0901	D	1"	F	1/2"	S-6 C.S.B. 6-250V	Large Convex	Side Screw	1-1/2" dia. lens	L-161
61-1310	D	1"	F	1/2"	T-3 1/4 M.B.B. 2-55V	Large Convex	Screw	1-1/2" dia. lens	L-161
61-3101	D	1"	F	3/4"	S-6 C.S.B. 6-250V	Large Convex	Protruding Screw	1-1/2" dia. lens	L-161
61-3202	D	1"	F	1/2"	S-6 D.C.B.B. 6-250V	Large Convex	Fixed Screw	1-1/2" dia. lens	L-161
61-3204	D	1"	F	1/2"	G-6 D.C.B.B. 6-32V	Large Convex	Fixed Screw	1-1/2" dia. lens	L-161
61-3402	D	1"	F	1/2"	S-6 D.C.B.B. 6-250V	Large Convex	Fixed Solder	1-1/2" dia. lens	L-161
61-3404	D	1"	F	1/2"	G-6 D.C.B.B. 6-32V	Large Convex	Fixed Solder	1-1/2" dia. lens	L-161
61-4001	D	1"	F	3/4"	S-6 C.S.B. 6-250V	Large Convex	Solder	1-1/2" dia. lens	L-161
61-6602	D	1"	F	1/2"	S-6 D.C.B.B. 6-250V	Large Convex	Quick Connect	1-1/2" dia. lens	L-161

See Note 1 on page 2.

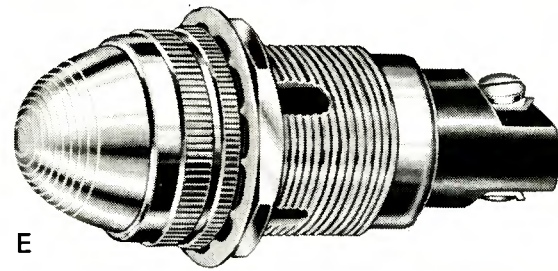
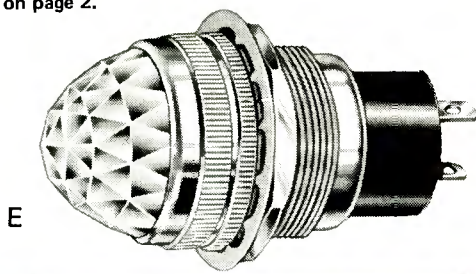

SERIES	ILLUS.	MTG. CLEAR. HOLE	PANEL INSERTION (F) FRONT (B) BACK	MAX. PANEL THICKNS.	LAMP ACCOMMO. & V. RANGE	LENS SHAPE	TERMINAL TYPE	SPECIAL FEATURES	DATA IN CAT. NO.
61-6604	D*	1"	F	1/2"	G-6 D.C.B.B. 6-32V	Large Convex	Quick Connect	1-1/2" dia. lens	L-161
61-6701	D*	1"	F	3/4"	S-6 C.S.B. 6-250V	Large Convex	Quick Connect	1-1/2" dia. lens	L-161
78-0901	G**	1"	F	3/4"	S-6 C.S.B. 6-250V	Convex	Side Screw	Dimmer-Polaroid	L-161
78-3101	G**	1"	F	5/8"	S-6 C.S.B. 6-250V	Convex	Screw	Dimmer-Polaroid	L-161
78-3202	G**	1"	F	3/4"	S-6 D.C.B.B. 6-250V	Convex	Screw	Dimmer-Polaroid	L-161
78-3402	G**	1"	F	3/4"	S-6 D.C.B.B. 6-250V	Convex	Solder	Dimmer-Polaroid	L-161
78-4001	G**	1"	F	5/8"	S-6 C.S.B. 6-250V	Convex	Solder	Dimmer-Polaroid	L-161
▲ 80-0410	E	1"	F	7/16"	T-3 1/4 M.B.B. 2-55V	Torpedo, Torpedo Faceted, Dome	Solder		L-161
▲ 80-0901	E	1"	F	5/8"	S-6 C.S.B. 6-250V	Torpedo, Torpedo Faceted, Dome	Side Screw		L-161
▲ 80-1310	E	1"	F	7/16"	T-3 1/4 M.B.B. 2-55V	Torpedo, Torpedo Faceted, Dome	Screw		L-161
▲ 80-3101	E	1"	F	1/2"	S-6 C.S.B. 6-250V	Torpedo, Torpedo Faceted, Dome	Protruding Screw		L-161
▲ 80-3202	E	1"	F	5/8"	S-6 D.C.B.B. 6-250V	Torpedo, Torpedo Faceted, Dome	Fixed Screw		L-161
▲ 80-3204	E	1"	F	7/16"	G-6 D.C.B.B. 6-32V	Torpedo, Torpedo Faceted, Dome	Fixed Screw		L-161
▲ 80-3402	E	1"	F	5/8"	S-6 D.C.B.B. 6-250V	Torpedo, Torpedo Faceted, Dome	Fixed Solder		L-161
▲ 80-3404	E	1"	F	7/16"	G-6 D.C.B.B. 6-32V	Torpedo, Torpedo Faceted, Dome	Fixed Solder		L-161
▲ 80-4001	E	1"	F	1/2"	S-6 C.S.B. 6-250V	Torpedo, Torpedo Faceted, Dome	Solder		L-161
▲ 80-6602	E	1"	F	5/8"	S-6 D.C.B.B. 6-250V	Torpedo, Torpedo Faceted, Dome	Quick Connect		L-161
▲ 80-6604	E	1"	F	7/16"	G-6 D.C.B.B. 6-32V	Torpedo, Torpedo Faceted, Dome	Quick Connect		L-161
▲ 80-6701	E	1"	F	1/2"	S-6 C.S.B. 6-250V	Torpedo, Torpedo Faceted, Dome	Quick Connect		L-161
151-3101	F**	1"	F	7/16"	S-6 C.S.B. 6-250V	Dome, 9/16" X 1" opening	Protruding Screw	Light Shield Lens Cap	L-161

* See illustration D on page 38

** See illustrations F and G on page 40

▲ Change prefix 80- to 31- to obtain assembly with friction-fit cap.

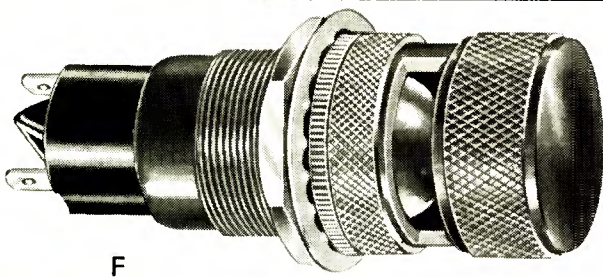

F

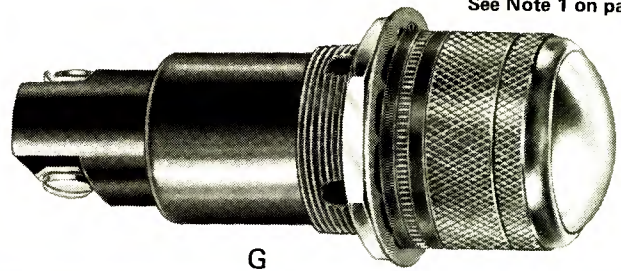

G

SERIES	ILLUS.	MTG. CLEAR. HOLE	PANEL INSERTION (F) FRONT (B) BACK	MAX. PANEL THICKNS.	LAMP ACCOMMO. & V. RANGE	LENS SHAPE	TERMINAL TYPE	SPECIAL FEATURES	DATA IN CAT. NO.
151-3202	F	1"	F	7/16"	S-6 D.C.B.B. 6-250V	Dome, 9/16" X 1" opening	Fixed Screw	Light Shield Lens Cap	L-161
151-3402	F	1"	F	7/16"	S-6 D.C.B.B. 6-250V	Dome, 9/16" X 1" opening	Solder	Light Shield Lens Cap	L-161
151-4001	F	1"	F	7/16"	S-6 C.S.B. 6-250V	Dome, 9/16" X 1" opening	Solder	Light Shield Lens Cap	L-161
151-6602	F	1"	F	7/16"	S-6 D.C.B.B. 6-250V	Dome, 9/16" X 1" opening	Quick Connect	Light Shield Lens Cap	L-161
151-6701	F	1"	F	7/16"	S-6 C.S.B. 6-250V	Dome, 9/16" X 1" opening	Quick Connect	Light Shield Lens Cap	L-161
154-3101	F	1"	F	1/2"	S-6 C.S.B. 6-250V	0" to 1/4" X 7/8" opening	Protruding Screw	Variable Light Shield Lens Cap	L-161
154-3202	F	1"	F	1/2"	S-6 D.C.B.B. 6-250V	0" to 1/4" X 7/8" opening	Fixed Screw	Variable Light Shield Lens Cap	L-161
154-3402	F	1"	F	1/2"	S-6 D.C.B.B. 6-250V	0" to 1/4" X 7/8" opening	Fixed Solder	Variable Light Shield Lens Cap	L-161
154-4001	F	1"	F	1/2"	S-6 C.S.B. 6-250V	0" to 1/4" X 7/8" opening	Solder	Variable Light Shield Lens Cap	L-161
154-6602	F	1"	F	1/2"	S-6 D.C.B.B. 6-250V	0" to 1/4" X 7/8" opening	Quick Connect	Variable Light Shield Lens Cap	L-161
154-6701	F	1"	F	1/2"	S-6 C.S.B. 6-250V	0" to 1/4" X 7/8" opening	Quick Connect	Variable Light Shield Lens Cap	L-161
209-0901	G	1"	F	1/2"	S-6 D.C.B.B. 6-250V	Convex	Side Screw	Dimmer-Mechanical	L-161
209-3101	G	1"	F	3/4"	S-6 C.S.B. 6-250V	Convex	Screw	Dimmer-Mechanical	L-161
209-3202	G	1"	F	1/2"	S-6 D.C.B.B. 6-250V	Convex	Screw	Dimmer-Mechanical	L-161
209-3402	G	1"	F	1/2"	S-6 D.C.B.B. 6-250V	Convex	Solder	Dimmer-Mechanical	L-161
209-4001	G	1"	F	3/4"	S-6 C.S.B. 6-250V	Convex	Solder	Dimmer-Mechanical	L-161
210-0901	G	1"	F	1/2"	S-6 C.S.B. 6-250V	Convex	Side Screw	Dimmer-Mechanical	L-161
210-3101	G	1"	F	3/4"	S-6 C.S.B. 6-250V	Convex	Screw	Dimmer-Mechanical	L-161
210-3202	G	1"	F	1/2"	S-6 D.C.B.B. 6-250V	Convex	Screw	Dimmer-Mechanical	L-161
210-3402	G	1"	F	1/2"	S-6 D.C.B.B. 6-250V	Convex	Solder	Dimmer-Mechanical	L-161
210-4001	G	1"	F	3/4"	S-6 C.S.B. 6-250V	Convex	Solder	Dimmer-Mechanical	L-161
225-3502	E*	1"	F	1/2"	S-6 D.C.B.B. 6-250V	Torpedo	Movable Screw	RFI Shielded	—

* See illustration E on page 39

See Note 1 on page 2.

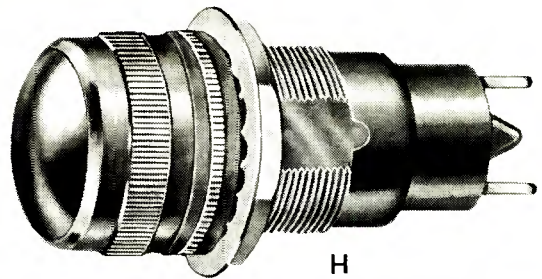
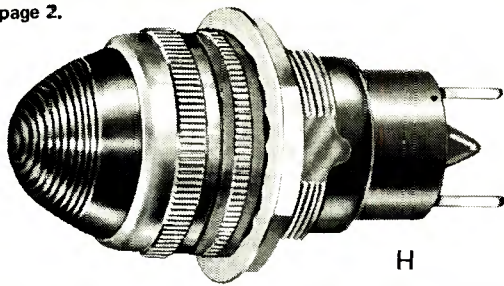

SERIES	ILLUS.	MTG. CLEAR. HOLE	PANEL INSERTION (F) FRONT (B) BACK	MAX. PANEL THICKNS.	LAMP ACCOMMO. & V. RANGE	LENS SHAPE	TERMINAL TYPE	SPECIAL FEATURES	DATA IN CAT. NO.
378-3402	H	1"	F	11/16"	S-6 D.C.B.B. 6-125V	Convex, Torpedo	Solder	Meet MIL-L-3661B	CR680 L-161
378-3404	H	1"	F	7/16"	G-6 D.C.B.B. 6-32V	Convex, Torpedo	Solder	Meet MIL-L-3661B	CR680 L-161
379-3402	H	1"	F	7/16"	G-6 D.C.B.B. 6-32V	Torpedo	Solder	Meet MIL-L-3661B	CR680 L-161
379-3404	H	1"	F	7/16"	G-6 D.C.B.B. 6-32V	Torpedo	Solder	Meet MIL-L-3661B	CR680 L-161
380-3402	G*	1"	F	7/16"	G-6 D.C.B.B. 6-32V	Convex	Solder	Meet MIL-L-3661B	CR680 L-161
380-3404	G*	1"	F	7/16"	G-6 D.C.B.B. 6-32V	Convex	Solder	Meet MIL-L-3661B	CR680 L-161
381-3402	G*	1"	F	7/16"	G-6 D.C.B.B. 6-32V	Convex	Solder	Meet MIL-L-3661B	CR680 L-161
381-3404	G*	1"	F	7/16"	G-6 D.C.B.B. 6-32V	Convex	Solder	Meet MIL-L-3661B	CR680 L-161

NEON

▲51-0914	J	1"	F	7/16"	T-4 1/2 C.S.B. 125-250V	Convex, Flat	Side Screw		L-161
▲51-3114	J	1"	F	7/16"	T-4 1/2 C.S.B. 125-250V	Convex, Flat	Protruding Screw		L-161
▲51-4014	J	1"	F	7/16"	T-4 1/2 C.S.B. 125-250V	Convex, Flat	Solder		L-161
▲51-6714	J	1"	F	7/16"	T-4 1/2 C.S.B. 125-250V	Convex, Flat	Quick Connect		L-161
▲80-0408	K	1"	F	7/16"	B1A (NE-51) M.B.B. 105-125V AC-DC	Dome, Stovepipe	Solder		L-161
▲80-0463	K	1"	F	7/16"	B2A (NE-51H) M.B.B. 110-125V AC	Dome, Stovepipe	Solder		L-161
▲80-0914	K	1"	F	7/16"	T-4 1/2 C.S.B. 125-250V	Dome, Stovepipe	Side Screw		L-161
▲80-1308	K	1"	F	7/16"	B1A (NE-51) M.B.B. 105-125V AC-DC	Dome, Stovepipe	Screw		L-161
▲80-1363	K	1"	F	7/16"	B2A (NE-51H) M.B.B. 110-125V AC	Dome, Stovepipe	Screw		L-161
▲80-3114	K	1"	F	1/4"	T-4 1/2 C.S.B. 125-250V	Dome, Stovepipe	Protruding Screw		L-161
▲80-4014	K	1"	F	1/4"	T-4 1/2 C.S.B. 125-250V	Dome, Stovepipe	Solder		L-161
▲80-6714	K	1"	F	1/4"	T-4 1/2 C.S.B. 125-250V	Dome, Stovepipe	Quick Connect		L-161
▲80-9363	K	1"	F	7/16"	B2A (NE-51H) M.B.B. 210-250V AC-DC	Dome, Stovepipe	Screw		L-161
▲80-9463	K	1"	F	7/16"	B2A (NE-51H) M.B.B. 210-250V AC-DC	Dome, Stovepipe	Solder		L-161

See Note 1 on page 2.

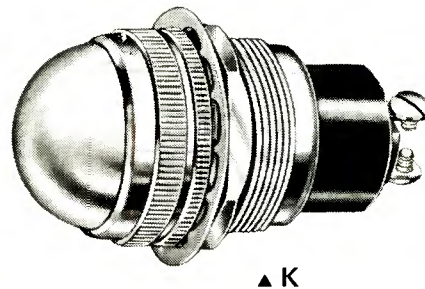
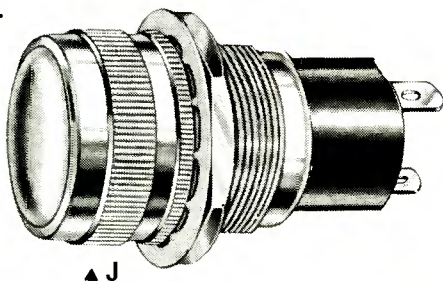

* See illustration G on page 40

▲ Change prefixes 51- or 80- to 31- to obtain assembly with friction-fit cap.

OPEN TYPE INDICATOR LIGHTS

Open type indicator lights are designed for use with one of the following incandescent lamps:

- *1- T-3 bulb with miniature bayonet base, from 6-120 volts.
All assemblies listed for use with T-3 1/4 M.B.B. will also accommodate the T-3 M.B.B.
- 2- T-3 1/4 bulb with miniature bayonet base, from 2-55 volts (listed as T-3 1/4 M.B.B.).
- 3- G-3 1/2 bulb with miniature bayonet base, from 7.5-18 volts (listed as G-3 1/2 M.B.B.).
- 4- S-6 bulb with candelabra screw base, from 6-145 volts (listed as S-6 C.S.B.).
- 5- S-6 bulb with double contact bayonet base, from 6-125 volts (listed as S-6 D.C.B.B.).
- 6- C-7 bulb with double contact bayonet base, from 6-120 volts (listed as C-7 D.C.B.B.).

Open type indicators are illustrated approx. 60% actual size.

Note: See Lens Cap section — pages 44-45 — for listing of lens caps for use with Open Type Indicators.

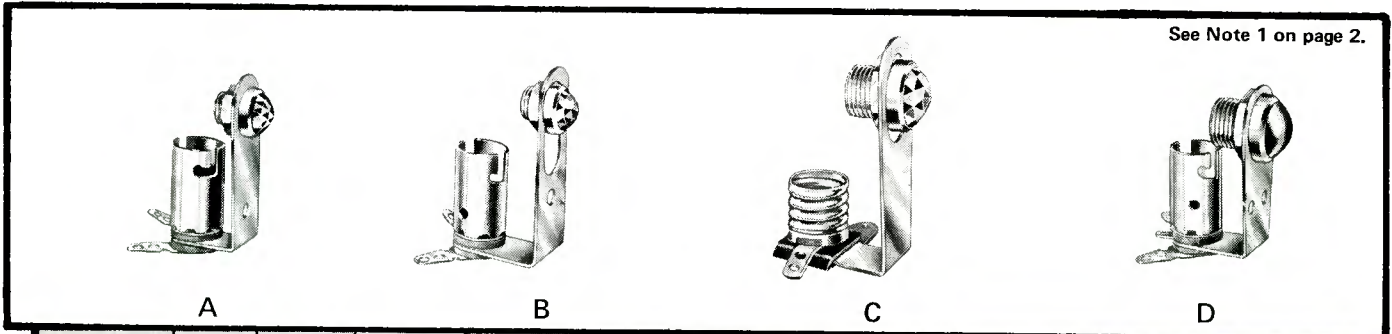

See Note 1 on page 2.

SERIES	ILLUS.	MTG. CLEAR. HOLE	LENS DIA.	LENS SHAPE	LAMP ACCOMMO. & V. RANGE	TERMINAL TYPE	SPECIAL FEATURES	DATA IN CAT. NO.
372-6236	N†	11/16"	1/2"	Convex	* T-3 1/4 M.B.B. 2-55V	Solder	Dimmer-Mechanical Meets MIL-L-3661B	CR680 L-161
372-6336	N†	11/16"	1/2"	Convex	* T-3 1/4 M.B.B. 2-55V	Solder	Dimmer-Mechanical Meets MIL-L-3661B	CR680 L-161
372-8136	N†	11/16"	1/2"	Convex	* T-3 1/4 M.B.B. 2-55V	Solder	Meets MIL-L-3661B	CR680 L-161
502-0530	A	9/32"	3/8"	Flat, Convex, Faceted	G-3 1/2 M.B.B. 7.5-18V	Solder		L-161
502-0531	B	9/32"	3/8"	Flat, Convex, Faceted	* T-3 1/4 M.B.B. 2-55V	Solder		L-161
502-1010	C	7/16"	1/2"	Flat, Convex, Faceted	S-6 C.S.B. 6-145V	Solder	Tamper Proof	L-161
502-1024	D	7/16"	1/2"	Flat, Convex, Faceted	G-3 1/2 M.B.B. 7.5-18V	Solder		L-161
502-1025	E	7/16"	1/2"	Flat, Convex, Faceted	* T-3 1/4 M.B.B. 2.55V	Solder		L-161

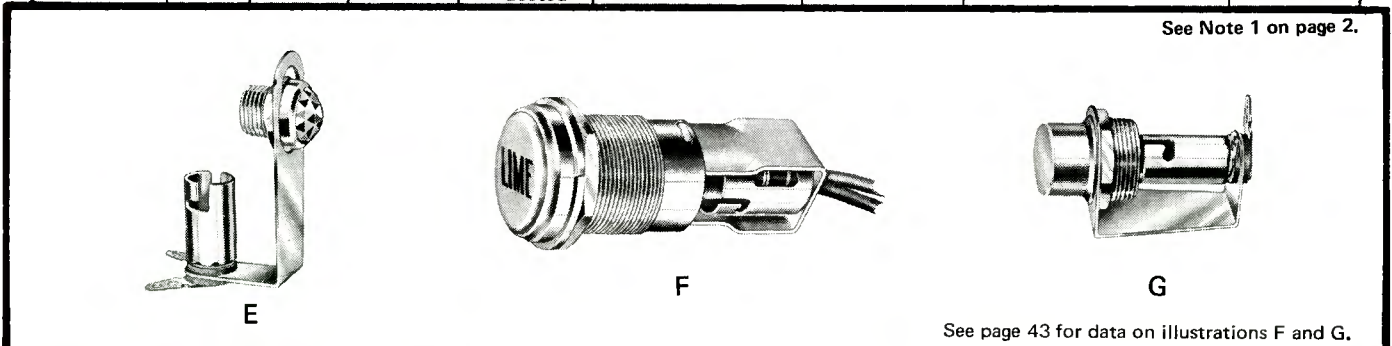

See Note 1 on page 2.

See page 43 for data on illustrations F and G.

† See illustration N on page 43

* See paragraph #1 above.

See Note 1 on page 2.

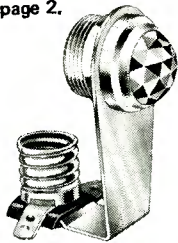

H

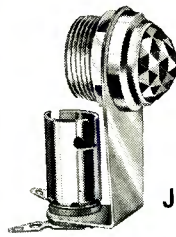

J

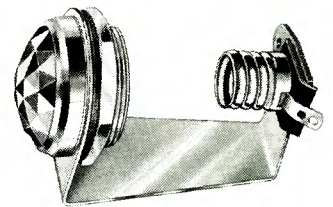

K

SERIES	ILLUS.	MTG. CLEAR. HOLE	LENS DIA.	LENS SHAPE	LAMP ACCOMMO. & V. RANGE	TERMINAL TYPE	SPECIAL FEATURES	DATA IN CAT. NO.
502-1813	F ▲	1"	1"	Flat	S-6 or C-7 D.C.B.B. 6-125V	Wire Leads	Tamper Proof	L-161
502-2436	G ▲	11/16"	5/8"	Cylin.	* T-3 1/4 M.B.B. 2-55V	Solder		L-161
502-2511	H	11/16"	5/8"	Convex, Faceted	S-6 C.S.B. 6-145V	Solder	Tamper Proof	L-161
502-2526	J	11/16"	5/8"	Flat, Convex, Faceted	* T-3 1/4 M.B.B. 2-55V	Solder		L-161
502-3214	K	1"	1"	Flat, Convex, Faceted	S-6 C.S.B. 6-145V	Solder		L-161
502-3241	—	1"	1"	Flat, Convex, Faceted	* T-3 1/4 M.B.B. 2-55V	Solder		L-161
502-5236	L	11/16"	5/8"	Stovepipe	* T-3 1/4 M.B.B. 2-55V	Solder		L-161
502-7633	M	1"	1"	Flat	S-6 or C-7 D.C.B.B. 6-125V	Wire Leads	Tamper Proof	L-161
502-7713	F	1"	1"	Flat	S-6 or C-7 D.C.B.B. 6-125V	Wire Leads	Tamper Proof	L-161
502-8136	N	11/16"	1/2"	Convex, Faceted	* T-3 1/4 M.B.B. 2-55V	Solder		L-161
502-9536	L	11/16"	5/8"	Stovepipe	* T-3 1/4 M.B.B. 2-55V	Solder		L-161

▲ See illustrations F and G on page 42

* See paragraph #1 on page 42

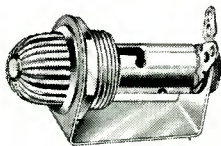

L



M

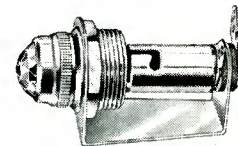

N

See Note 1 on page 2.

FLASHING INDICATOR LIGHT

The flashing indicator includes a special aged, seasoned and selected high brightness neon T-2 bulb with midget flanged base (listed as T-2 M.F.B.)

SERIES	ILLUS.	MTG. CLEAR. HOLE	PANEL INSERTION (F) FRONT (B) BACK	MAX. PANEL THICKNS.	LAMP ACCOMMO. & V. RANGE	LENS SHAPE	TERMINAL TYPE	DATA IN CAT. NO.
538*	A	.775 .775 x	Snap-in	3/16"	C2A (NE-2H) 110-125V AC	Square	Solderable	L-211
539	A	.775 .775 x	Snap-in	3/16"	C2A (NE-2H) 110-125V AC	Square	Solderable	L-211

*Matching indicator for use with 539 Series Flasher

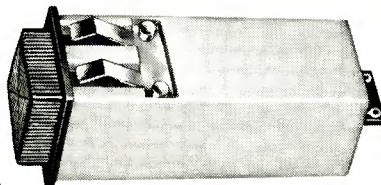

A

LENS CAP ASSEMBLIES

For Panel Mounting Or Use With Open Assemblies

SERIES	ILLUS.	LENS SHAPE	LENS DIA.	SHANK O.D.	SHANK LENGTH	SPECIAL FEATURES	DATA IN CAT. NO.
31-0111	A	Convex	1"	.885	5/16"		L-161
31-0211	A	Flat	1"	.885	5/16"		L-161
31-0431	A	Faceted	1"	.885	5/16"		L-161
31-1211	A	Dome	1"	.885	5/16"		L-161
31-1331	A	Torpedo Faceted	1"	.885	5/16"		L-161
34-0431	B	Faceted	1 1/2"	-----	-----	Snap-in Mtg. Clearance Hole 1 3/8"	L-161
34-0831	B	Dome	1 1/2"	-----	-----	Snap-in Mtg. Clearance Hole 1 3/8"	L-161
81-0331	C	Flat	1/2"	9/16"-27 thd.	3/16"	Meets MIL-L-3661B	L-161
81-0631	C	Convex	1/2"	9/16"-27 thd.	3/16"		L-161
81-2131	C	Faceted	1/2"	9/16"-27 thd.	3/16"		L-161
95-0931	D	Stovepipe	5/8"	9/16"-27 thd.	3/16"		L-161
132-0991	E	Stovepipe	5/8"	9/16"-27 thd.	3/16"		L-161
135-1431	F	Cylindrical	5/8"	9/16"-27 thd.	3/16"		L-161
▲402-01xx	G	Convex	11/32"	.348	3/16"		L-161
▲402-08xx	G	Dome	11/32"	.348	3/16"		L-161
514-0408	H*	Flat, Convex, Faceted	11/32"	.276	1/4"		L-161
514-0508	J*	Flat, Convex, Faceted	11/32"	9/32"-32 thd.	1/4"		L-161
514-0512	J*	Flat, Convex, Faceted	11/32"	9/32"-32 thd.	3/8"		L-161
514-0608	K*	Flat, Convex, Faceted	11/32"	.285	1/4"		L-161

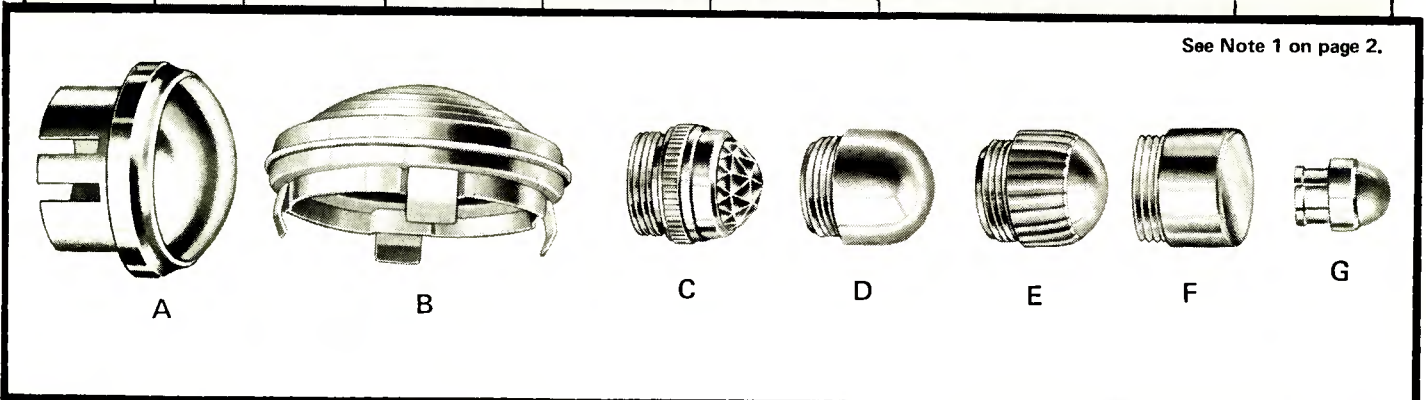

See Note 1 on page 2.

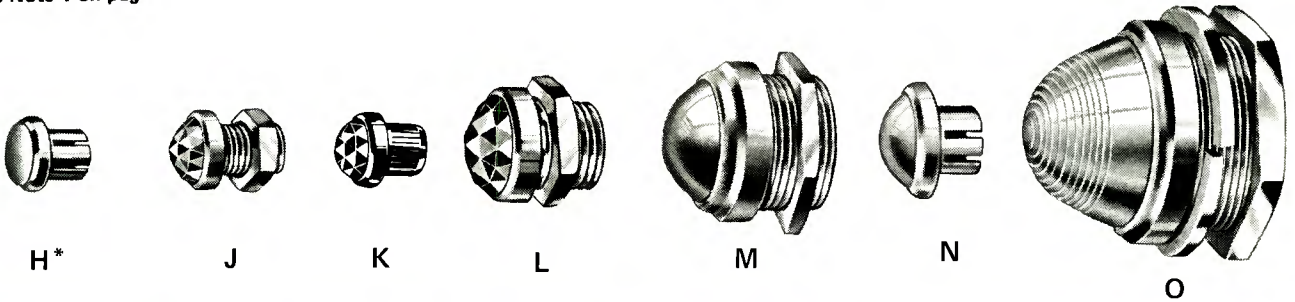

SERIES	ILLUS.	LENS SHAPE	LENS DIA.	SHANK O.D.	SHANK LENGTH	SPECIAL FEATURES	DATA IN CAT. NO.
514-0710	J	Flat, Convex, Faceted	11/32"	3/8" - 24 thd.	5/16"		L-161
514-1008	K	Flat, Convex, Faceted	1/2"	7/16" - 27 thd.	1/4"		L-161
514-1012	L	Flat, Convex, Faceted	1/2"	7/16" - 27 thd.	3/8"		L-161
514-2512	M	Convex, Faceted	5/8"	11/16" - 27 thd.	3/8"		L-161
514-3806	N	Flat, Convex, Faceted	1/2"	.373	3/16"		L-161
514-7612	O	Flat, Convex, Faceted, Torpedo	1"	1" - 27 thd.	3/8"		L-161

* See data for illustration H on page 44

SOCKET ASSEMBLIES

SERIES	ILLUS.	LAMP ACCOMMO. & VOLTAGE RANGE	SPECIAL FEATURES	DATA IN CATALOG NO.
503-4634	A	S6 and C7, double contact; candelabra or bayonet base. Up to 125V	Meet requirements of MIL-L-3661B	CR680
503-4931	B	T-3 1/4 M. B. B. 2-55V	Meet requirements of MIL-L-3661B	CR680

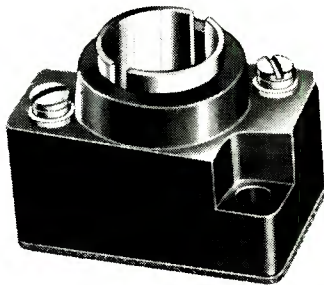

A

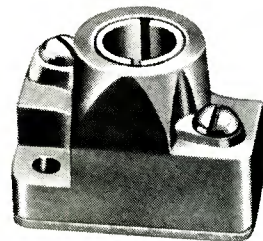

B

OIL-TIGHT INDICATOR LIGHTS

Oil tight, water tight, dust tight on the face of the panel.

Oil-Tight Indicator Lights are designed for mounting in 11/16", 1" or 1 3/16" clearance hole.

Incandescent Oil-Tight Indicator Lights accommodate the following lamps with listed voltage ratings:

1. T-3/4 with Miniature Bayonet Base (listed as T-3/4 M.B.B.) – 2-55 volts.
2. S-6 with Candelabra Screw Base (listed as S-6 C.S.B.) – 6-250 volts.
3. S-6 with Double Contact Bayonet Base (listed as S-6 D.C.B.B.) – 6-250 volts.
4. S-6 with Intermediate Screw Base (listed as S-6 I.S.B.) – 125-250 volts.
5. C-7 with Double Contact Bayonet Base (listed as C-7 D.C.B.B.) – 120 volts only.

Neon Oil-Tight Indicator Lights accommodate the following lamps with designated voltage ratings:

1. Standard brightness B1A (NE-51) with Miniature Bayonet Base – listed as B1A (NE-51) M.B.B. – 105-125 volts AC-DC.
2. High brightness B2A (NE-51H) with Miniature Bayonet Base – listed as B2A (NE-51H) M.B.B. – 110-125 volts AC or 210-250 volts AC-DC.
3. T-4½ with Candelabra Screw Base (listed as T-4½ C.S.B.) – 105-250 volts.
4. B9A (NE-48) with Double Contact Bayonet Base – listed as B9A (NE-48) D.C.B.B. – 105-250 volts.
5. R1A (NE-79) with Double Contact Bayonet Base – listed as R1A (NE-79) D.C.B.B. – 105-250 volts.

Some assemblies accommodating bayonet based lamps have the necessary current-limiting resistor built-in (an exclusive Dialco feature – U. S. Pat. No. 2,421,321). Screw based lamps have the required current-limiting resistor built into the base of the lamp, and therefore none is built into the base of the assembly.

INCANDESCENT

SERIES	ILLUS.	MTG. CLEAR. HOLE	PANEL INSERTION (F) FRONT (B) BACK	MAX. PANEL THICKNS.	LAMP ACCOMMO. & V. RANGE	LENS SHAPE	TERMINAL TYPE	SPECIAL FEATURES	DATA IN CAT. NO.
103-0901	A	1"	F	1/2"	S-6 C.S.B. 6-250V	Dome, Torpedo, Torpedo faceted	Side Screw		L-200
103-3101	A	1"	F	7/16"	S-6 C.S.B. 6-250V	Dome, Torpedo, Torpedo faceted	Protruding Screw		L-200
103-3202	A	1"	F	1/2"	S-6 D.C.B.B. 6-250V	Dome, Torpedo, Torpedo faceted	Movable Screw		L-200
103-3227	A	1"	F	1/2"	C-7 D.C.B.B. 120V	Dome, Torpedo, Torpedo faceted	Fixed Screw		L-200
103-3402	A	1"	F	1/2"	S-6 D.C.B.B. 6-250V	Dome, Torpedo, Torpedo faceted	Fixed Solder		L-200
103-3427	A	1"	F	1/2"	C-7 D.C.B.B. 120V	Dome, Torpedo, Torpedo faceted	Fixed Solder		L-200
103-3502	A	1"	F	1/2"	S-6 D.C.B.B. 6-250V	Dome, Torpedo, Torpedo faceted	Movable Screw		L-200
103-3527	A	1"	F	1/2"	C-7 D.C.B.B. 120V	Dome, Torpedo, Torpedo faceted	Movable Screw		L-200

See Note 1 on page 2.

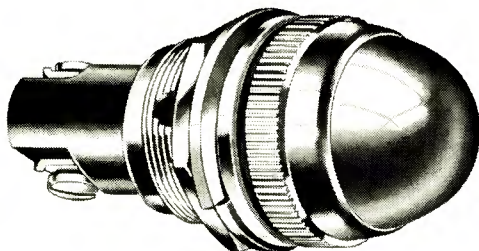

A

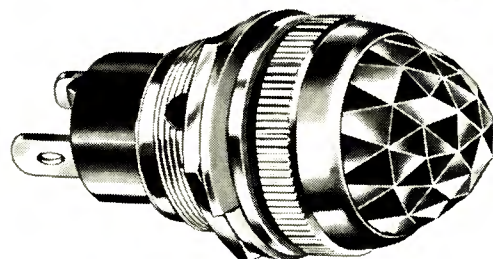

A

See Note 1 on page 2.

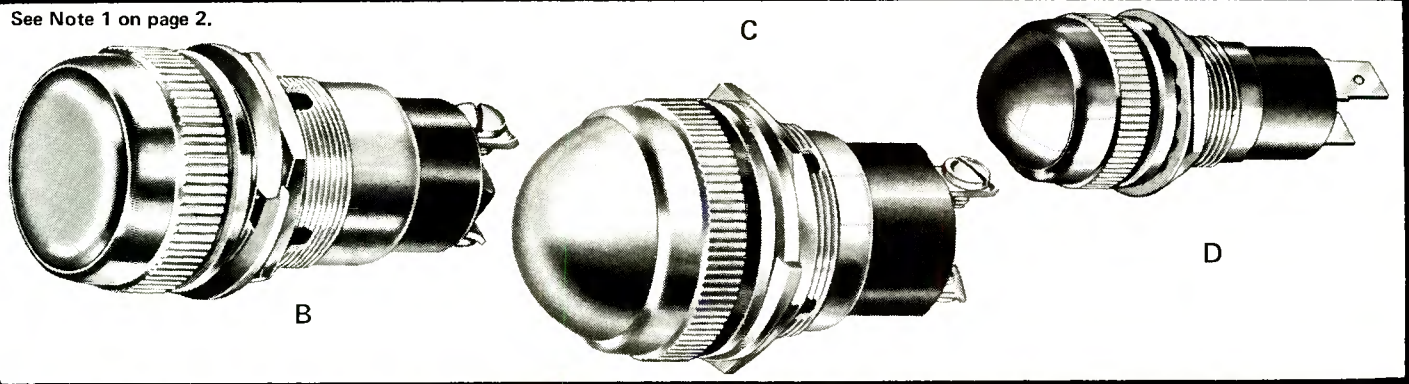

SERIES	ILLUS.	MTG. CLEAR. HOLE	PANEL INSERTION (F) FRONT (B) BACK	MAX. PANEL THICKNS.	LAMP ACCOMMO. & V. RANGE	LENS SHAPE	TERMINAL TYPE	SPECIAL FEATURES	DATA IN CAT. NO.
103-3602	A*	1"	F	1/2"	S-6 D.C.B.B. 6-250V	Dome, Torpedo, Torpedo faceted	Movable Solder		L-200
103-3627	A*	1"	F	1/2"	C-7 D.C.B.B. 120V	Dome, Torpedo, Torpedo faceted	Fixed Screw		L-200
103-4001	A*	1"	F	7/16"	S-6 C.S.B. 6-250V	Dome, Torpedo, Torpedo faceted	Solder		L-200
104-0901	B	1"	F	1/2"	S-6 C.S.B. 6-250V	Flat	Side Screw		L-200
104-3101	B	1"	F	1/2"	S-6 C.S.B. 6-250V	Flat	Protruding Screw		L-200
104-3202	B	1"	F	1/2"	S-6 D.C.B.B. 6-250V	Flat	Fixed Screw		L-200
104-3227	B	1"	F	1/2"	C-7 D.C.C.B. 120V	Flat	Movable Screw		L-200
104-3402	B	1"	F	1/2"	S-6 D.C.B.B. 6-250V	Flat	Fixed Solder		L-200
104-3427	B	1"	F	1/2"	C-7 D.C.B.B. 120V	Flat	Fixed Solder		L-200
104-3502	B	1"	F	1/2"	S-6 D.C.B.B. 6-250V	Flat	Movable Screw		L-200
104-3527	B	1"	F	1/2"	C-7 D.C.B.B. 120V	Flat	Movable Screw		L-200
104-3602	B	1"	F	1/2"	S-6 D.C.B.B. 6-250V	Flat	Movable Solder		L-200
104-3627	B	1"	F	1/2"	C-7 D.C.B.B. 120V	Flat	Movable Solder		L-200
104-4001	B	1"	F	1/2"	S-6 C.S.B. 6-250V	Flat	Solder		L-200
115-4733	C	1-3/16"	F	13/32"	S-6 I.S.B. 125-250V	Dome	Screw		L-200
115-4833	C	1-3/16"	F	13/32"	S-6 I.S.B. 125-250V	Dome	Solder		L-200
116-4733	C	1-3/16"	F	13/32"	S-6 I.S.B. 125-250V	Flat	Screw		L-200
116-4833	C	1-3/16"	F	13/32"	S-6 I.S.B. 125-250V	Flat	Solder		L-200
123-0410	D	11/16"	F	5/16"	T-3 1/4 M.B.B. 2-55V	Dome	Solder		L-200
123-1310	D	11/16"	F	5/16"	T-3 1/4 M.B.B. 2-55V	Dome	Quick Connect		L-200
123-5710	D	11/16"	F	5/16"	T-3 1/4 M.B.B. 2-55V	Dome	Quick Connect		L-200
124-0410	D	11/16"	F	5/16"	T-3 1/4 M.B.B. 2-55V	Convex	Solder		L-200
124-1310	D	11/16"	F	5/16"	T-3 1/4 M.B.B. 2-55V	Convex	Screw		L-200
124-5710	D	11/16"	F	5/16"	T-3 1/4 M.B.B. 2-55V	Convex	Quick Connect		L-200

* See illustration A on page 46

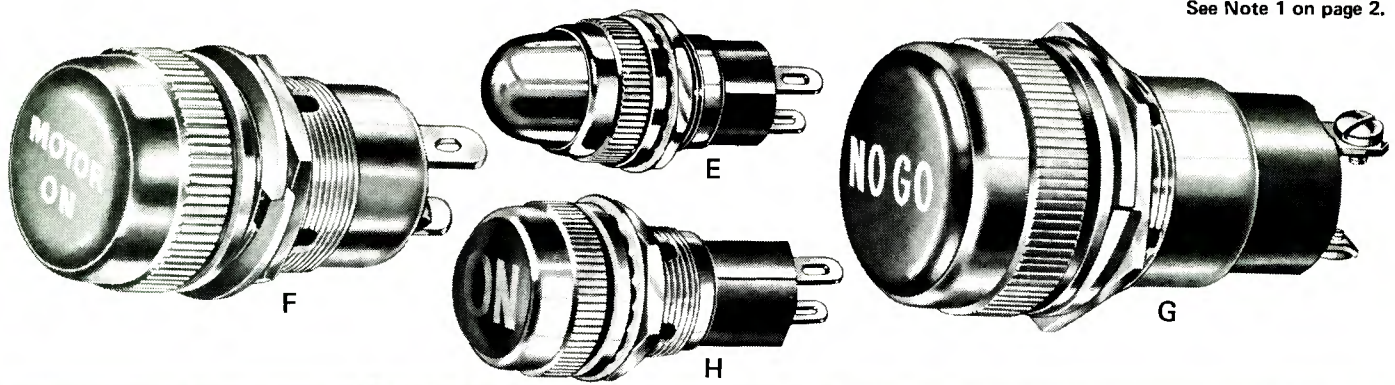

SERIES	ILLUS.	MTG. CLEAR. HOLE	PANEL INSERTION (F) FRONT (B) BACK	MAX. PANEL THICKNS.	LAMP ACCOMMO. & V. RANGE	LENS SHAPE	TERMINAL TYPE	SPECIAL FEATURES	DATA IN CAT. NO.
125-0410	E	11/16"	F	7/32"	T-3 1/4 M.B.B. 2-55V	Stovepipe	Solder		L-200
125-1310	E	11/16"	F	7/32"	T-3 1/4 M.B.B. 2-55V	Stovepipe	Screw		L-200
125-5710	E	11/16"	F	7/32"	T-3 1/4 M.B.B. 2-55V	Stovepipe	Quick Connect		L-200
215-0901	F	1"	F	1/2"	S-6 C.S.B. 6-250V	Flat	Side Screw	w/film legend disc	L-200
215-3101	F	1"	F	1/2"	S-6 C.S.B. 6-250V	Flat	Protruding Screw	w/film legend disc	L-200
215-3202	F	1"	F	1/2"	S-6 D.C.B.B. 6-250V	Flat	Fixed Screw	w/film legend disc	L-200
215-3227	F	1"	F	1/2"	C-7 D.C.B.B. 120V	Flat	Fixed Screw	w/film legend disc	L-200
215-3402	F	1"	F	1/2"	S-6 D.C.B.B. 6-250V	Flat	Fixed Solder	w/film legend disc	L-200
215-3427	F	1"	F	1/2"	C-7 D.C.B.B. 120V	Flat	Fixed Solder	w/film legend disc	L-200
215-3502	F	1"	F	1/2"	S-6 D.C.B.B. 6-250V	Flat	Movable Screw	w/film legend disc	L-200
215-3527	F	1"	F	1/2"	C-7 D.C.B.B. 120V	Flat	Movable Screw	w/film legend disc	L-200
215-3602	F	1"	F	1/2"	S-6 D.C.B.B. 6-250V	Flat	Movable Solder	w/film legend disc	L-200
215-3627	F	1"	F	1/2"	C-7 D.C.B.B. 120V	Flat	Movable Solder	w/film legend disc	L-200
215-4001	F	1"	F	1/2"	S-6 C.S.B. 6-250V	Flat	Solder	w/film legend disc	L-200
216-4733	G	1-3/16"	F	13/32"	S-6 I.S.B. 125-250V	Flat	Screw	w/film legend disc	L-200
216-4833	G	1-3/16"	F	13/32"	S-6 I.S.B. 125-250V	Flat	Solder	w/film legend disc	L-200
218-0410	H	11/16"	F	5/16"	T-3 1/4 M.B.B. 2-55V	Convex	Solder	w/film legend disc	L-200
218-1310	H	11/16"	F	5/16"	T-3 1/4 M.B.B. 2-55V	Convex	Screw	w/film legend disc	L-200
218-5710	H	11/16"	F	5/16"	T-3 1/4 M.B.B. 2-55V	Convex	Quick Connect	w/film legend disc	L-200
NEON									
103-0914	J*	1"	F	5/16"	T-4 1/2 C.S.B. 105-250V	Dome	Side Screw		L-200
103-3114	J*	1"	F	5/16"	T-4 1/2 C.S.B. 105-250V	Dome	Protruding Screw		L-200
103-4014	J*	1"	F	5/16"	T-4 1/2 C.S.B. 105-250V	Dome	Solder		L-200
103-5306	J*	1"	F	1/2"	B9A (NE-48) 105-250V	Dome	Movable Solder	Built-in resistor	L-200
103-5406	J*	1"	F	1/2"	B9A (NE-48) 105-250V	Dome	Movable Screw	Built-in resistor	L-200

* See illustration J on page 49

See Note 1 on page 2.

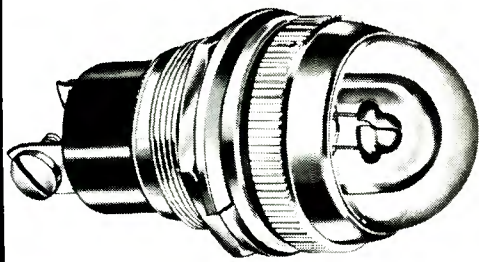

J*

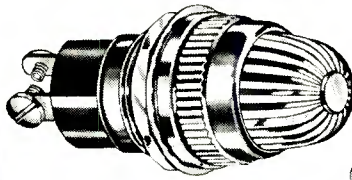

K

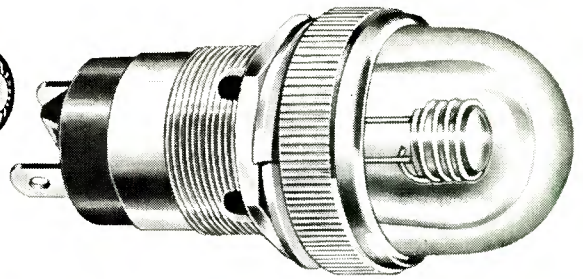

L

SERIES	ILLUS.	MTG. CLEAR. HOLE	PANEL INSERTION (F) FRONT (B) BACK	MAX. PANEL THICKNS.	LAMP ACCOMMO. & V. RANGE	LENS SHAPE	TERMINAL TYPE	SPECIAL FEATURES	DATA IN CAT. NO.
123-0408	K	11/16"	F	5/16"	B1A (NE-51) 105-125V AC-DC	Dome	Solder	Built-in resistor	L-200
123-0463	K	11/16"	F	5/16"	B2A (NE-51H) 110-125V AC	Dome	Solder	Built-in resistor	L-200
123-1308	K	11/16"	F	5/16"	B1A (NE-51) 105-125V AC-DC	Dome	Screw	Built-in resistor	L-200
123-1363	K	11/16"	F	5/16"	B2A (NE-51H) 110-125V AC	Dome	Screw	Built-in resistor	L-200
123-5708	K	11/16"	F	5/16"	B1A (NE-51) 105-125V AC-DC	Dome	Quick Connect	Built-in resistor	L-200
123-5763	K	11/16"	F	5/16"	B2A (NE-51H) 110-125V AC	Dome	Quick Connect	Built-in resistor	L-200
123-5863	K	11/16"	F	5/16"	B2A (NE-51H) 210-250V AC-DC	Dome	Quick Connect	Built-in resistor	L-200
123-9363	K	11/16"	F	5/16"	B2A (NE-51H) 210-250V AC-DC	Dome	Screw	Built-in resistor	L-200
123-9463	K	11/16"	F	5/16"	B2A (NE-51H) 210-250V AC-DC	Dome	Solder	Built-in resistor	L-200
125-0408	K	11/16"	F	7/32"	B1A (NE-51) 105-125V AC-DC	Stovepipe	Solder	Built-in resistor	L-200
125-0463	K	11/16"	F	7/32"	B2A (NE-51H) 110-125V AC	Stovepipe	Solder	Built-in resistor	L-200
125-1308	K	11/16"	F	7/32"	B1A (NE-51) 105-125V AC-DC	Stovepipe	Screw	Built-in resistor	L-200
125-1363	K	11/16"	F	7/32"	B2A (NE-51H) 110-125V AC	Stovepipe	Screw	Built-in resistor	L-200
125-5708	K	11/16"	F	7/32"	B1A (NE-51) 105-125V AC-DC	Stovepipe	Quick Connect	Built-in resistor	L-200
125-5763	K	11/16"	F	7/32"	B2A (NE-51H) 110-125V AC	Stovepipe	Quick Connect	Built-in resistor	L-200
125-5863	K	11/16"	F	7/32"	B2A (NE-51H) 210-250V AC-DC	Stovepipe	Quick Connect	Built-in resistor	L-200
125-9363	K	11/16"	F	7/32"	B2A (NE-51H) 210-250V AC-DC	Stovepipe	Screw	Built-in resistor	L-200
125-9463	K	11/16"	F	7/32"	B2A (NE-51H) 210-250V AC-DC	Stovepipe	Solder	Built-in resistor	L-200
159-3537	L	1"	F	7/16"	R1A (NE-79) 105-250V	Stovepipe	Movable Screw	w/o built-in resistor	L-200
159-3637	L	1"	F	7/16"	R1A (NE-79) 105-250V	Stovepipe	Movable Solder	w/o built-in resistor	L-200
159-5337	L	1"	F	9/16"	R1A (NE-79) 105-250V	Stovepipe	Movable Solder	Built-in resistor	L-200
159-5437	L	1"	F	9/16"	R1A (NE-79) 105-250V	Stovepipe	Movable Screw	Built-in resistor	L-200

* See data on page 48

PRESS-TO-TEST INDICATOR LIGHTS

Positive safety factors are provided by patented built-in Press-to-Test Indicator Lights. Lamps can be checked - instantly - without removing lamps from the assemblies.

These indicator lights are designed for mounting in 15/32", 5/8" or 1" clearance holes. The incandescent light source is either the T-1 3/4 bulb with midget flanged base (listed as T-1 3/4 M.F.B.) - in a range of voltages from 1.35-28V; or T-3 1/4 bulb with miniature bayonet base (listed as T-3 1/4 M.B.B.) - from 2-55V.

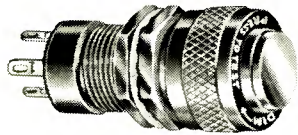

A

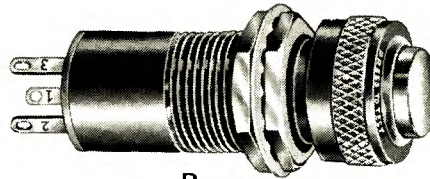

B

See Note 1 on page 2.

SERIES	ILLUS.	MTG. CLEAR. HOLE	PANEL INSERTION (F) FRONT (B) BACK	MAX. PANEL THICKNS.	LAMP ACCOMMO. & V. RANGE	LENS SHAPE	TERMINAL TYPE	SPECIAL FEATURES	DATA IN CAT. NO.
800-1030	A	15/32"	B	5/16"	T-1 3/4 M.F.B. 1.35-28V	Flat	3 terminal, Solder	Meet MS25041 per MIL-L-7961B	L-201 CR680
801-1030	A	15/32"	B	5/16"	T-1 3/4 M.F.B. 1.35-28V	Flat	3 terminal, Solder	Dimmer-Mechanical, Meet MS25041 per MIL-L-7961B	L-201 CR680
803-1710	B	5/8"	B	3/8"	T-3 1/4 M.B.B. 2-55V	Flat	3 terminal, Solder	Meet MS25331 per MIL-L-7961B	L-201 CR680
804-1710	C	5/8"	B	3/8"	T-3 1/4 M.B.B. 2-55V	Flat	3 terminal, Solder	Dimmer-Mechanical, Meet MS25331 per MIL-L-7961B	L-201 CR680
806-1710	D	5/8"	B	3/8"	T-3 1/4 M.B.B. 2-55V	Faceted	3 terminal, Solder	Non-Dimmer, 1" dia. lens	L-201
806-1810	D	5/8"	B	3/8"	T-3 1/4 M.B.B. 2-55V	Faceted	4 terminal, Solder	Non-Dimmer, 1" dia. lens	L-201
808-1130	A	15/32"	B	5/16"	T-1 3/4 M.F.B. 1.35-28V	Flat	4 terminal, Solder		L-201
809-1130	A	15/32"	B	5/16"	T-1 3/4 M.F.B. 1.35-28V	Flat	4 terminal, Solder	Dimmer-Mechanical	L-201

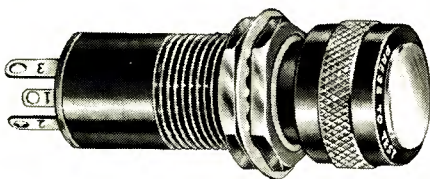

C

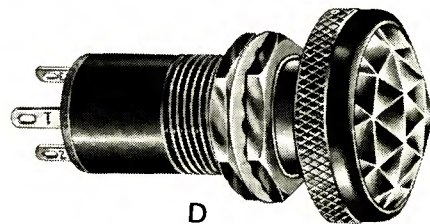

D

See Note 1 on page 2.

See Note 1 on page 2.

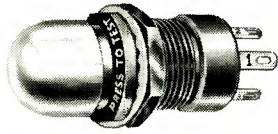

E

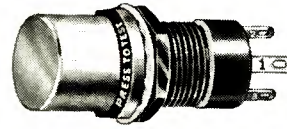

F

SERIES	ILLUS.	MTG. CLEAR. HOLE	PANEL INSERTION (F) FRONT (B) BACK	MAX. PANEL THICKNS.	LAMP ACCOMMO. & V. RANGE	LENS SHAPE	TERMINAL TYPE	SPECIAL FEATURES	DATA IN CAT. NO.
810-1810	B *	5/8"	B	3/8"	T-3 1/4 M.B.B. 2-55V	Flat	4 terminal, Solder		L-201
811-1810	C *	5/8"	B	3/8"	T-3 1/4 M.B.B. 2-55V	Flat	4 terminal, Solder	Dimmer-Mechanical	L-201
812-1030	E	15/32"	B	5/16"	T-1 3/4 M.F.B. 1.35-28V	Stovepipe	3 terminal, Solder	Round flange nut	L-201
812-1130	E	15/32"	B	5/16"	T-1 3/4 M.F.B. 1.35-28V	Stovepipe	4 terminal, Solder	Round flange nut	L-201
813-1030	F	15/32"	B	5/16"	T-1 3/4 M.F.B. 1.35-28V	Cylindrical	3 terminal, Solder	Round flange nut	L-201
813-1130	F	15/32"	B	5/16"	T-1 3/4 M.F.B. 1.35-28V	Cylindrical	4 terminal, Solder	Round flange nut	L-201

* See illustrations B and C on page 50

TRANSISTORIZED INDICATOR LIGHTS

Transistorized indicators offer a choice of neon or incandescent light sources. The former is a non-replaceable neon lamp, the latter a T-1 3/4 bulb with midget flanged base (listed as T-1 3/4 M.F.B.).

See Note 1 on Page 2.

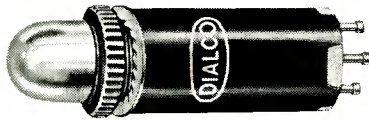

A



B

SERIES	ILLUS.	MTG. CLEAR. HOLE	PANEL INSERTION (F) FRONT (B) BACK	MAX. PANEL THICKNS	LAMP ACCOMMO. & V. RANGE	LENS SHAPE	TERMINAL TYPE	SPECIAL FEATURES	DATA IN CAT. NO.
901-1478	A	15/32"	B	3/16"	Cylindrical	Turret	Meet requirements of MIL-L-3661B	CR680
901-1537	A	3/8"	B	3/16"	Cylindrical	Solder blade	non-replaceable Neon lamp	L-210
903-1458	A	15/32"	B	3/16"	T-1 3/4 M.F.B. 3.6-5V	Cylindrical, Stovepipe	Turret		L-207
903-1476	A	15/32"	B	3/16"	T-1 3/4 M.F.B. (MS18209-387)	Cylindrical, Stovepipe	Turret	Meet requirements of MIL-L-3661B	CR680
907-1458	B	3/8"	B	3/16"	T-1 3/4 M.F.B. 5V	Cylindrical	Solder blade		L-210

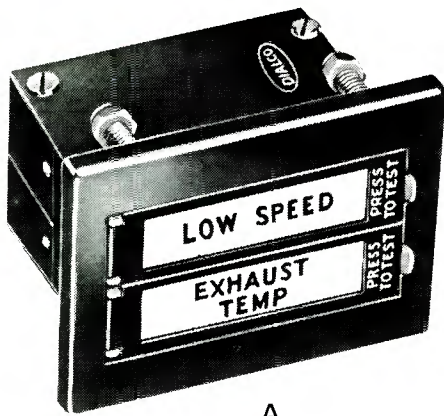

A

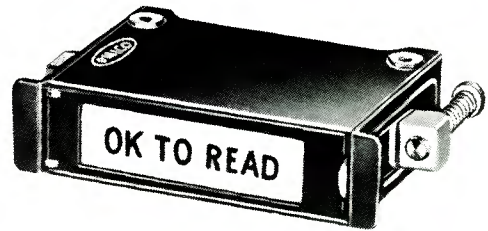

B

PLACARD LIGHTS

In addition to MIL-L-3661B, these assemblies conform to the environmental and operational requirements of MIL-E-5272, ABMA-MPD-11023 and 11064.

Placard lights accommodate two T-1 3/4 bulbs with midget flanged base, incandescent – in a range of voltages from 6-28V. All Placard Lights are available singly, or (with the exception of the end-mounting type) can be furnished in stacks of up to 10 indicators.

SERIES	ILLUS.	MOUNTING METHOD	PANEL INSERTION (F) FRONT (B) BACK	LAMP ACCOMMO. & V. RANGE	SPECIAL FEATURES	DATA IN CAT. NO.
520-1291	A	Escutcheon	F	Two T-1 3/4 M.F.B. 6-28V	Non-Press-to-Test, 2 terminals, MIL-L-3661B	L-170 CR680
520-1292	A	Escutcheon	F	Two T-1 3/4 M.F.B. 6-28V	Press-to-Test, 3 terminals, MIL-L-3661B	L-170 CR680
520-2281	B	End Mounting	F	Two T-1 3/4 M.F.B. 6-28V	Non-Press-to-Test, 2 terminals	L-170
520-2282	B	End Mounting	F	Two T-1 3/4 M.F.B. 6-28V	Press-to-Test, 3 terminals	L-170
520-3281	C	Side Mounting	F	Two T-1 3/4 M.F.B. 6-28V	Non-Press-to-Test, 2 terminals	L-170
520-3282	C	Side Mounting	F	Two T-1 3/4 M.F.B. 6-28V	Press-to-Test, 3 terminals	L-170
520-4281	D	"L" Angle Bracket	F or B	Two T-1 3/4 M.F.B. 6-28V	Non-Press-to-Test, 2 terminals	L-170
520-4282	D	"L" Angle Bracket	F or B	Two T-1 3/4 M.F.B. 6-28V	Press-to-Test, 3 terminals	L-170

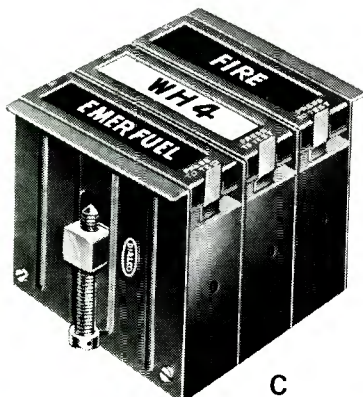

C

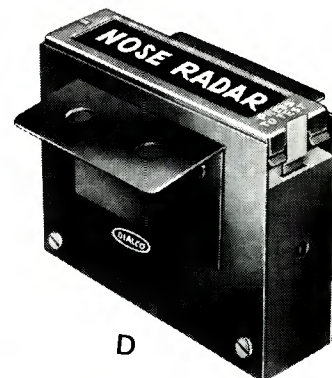

D

INDICATORS WITH PANEL OR SNAP-IN MOUNTING FEATURE

PANEL MOUNTING TYPE

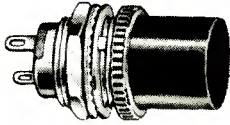

183-9830 SERIES

These indicators offer choice of panel or snap-in mounting feature.

Panel mounting indicators (183 - Series) accommodate all lens caps on the following page; snap-in mounting indicators with bezels accommodate either square (300 Series), round (301 Series) or rectangular (303 or 534 Series) caps.

SNAP-IN MOUNTING TYPE

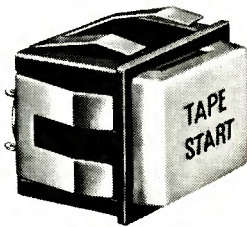

533 SERIES

The light source is the T-1 3/4 bulb with midget flanged base, incandescent, in a range of voltages up to 28V.

SERIES	ILLUS.	MTG. CLEAR. HOLE	PANEL MTG.	MAX. PANEL THKNS.	SPECIAL FEATURES	DATA IN CATALOG NO.
183-9730	A	15/32"	Front	3/16"	Anti-Rotation	L-210
183-9830	B	1/2"	Front or Rear	3/16"	Anti-Rotation	L-210
533-06XX	C	.758 x .758	Snap-in	3/16"	Accommodates 300 Series Cap.	L-210
533-07XX	D	.753 dia.	Snap-in	3/16"	Accommodates 301 Series Cap.	L-210
533-09XX	E	.870 x 1.110	Snap-in	3/16"	Accommodates 303 or 534 Series Cap.	L-210
533-10XX	F	.870 x 1.110	Snap-in	3/16"	W/barrier. Accommodates 303 or 534 Series Cap.	L-210
533-11XX	G	.883 x .883	Snap-in	3/16"	Accommodates 300 Series Cap with Kap-Kover.	L-210

See Note 1 on page 2.



A
Front Mtg.
Matching Indicator



B
Front or Rear Mtg.
Matching Indicator



C
Snap-in Mtg.
Matching Indicator
w/ 5/8" Sq. Bezel



D

Snap-in Mtg.
Matching Indicator
w/ 5/8" Rnd. Bezel

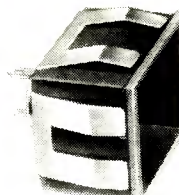

E
Snap-in Mtg.
Matching Indicator
w/ 3/4" x 1" Bezel

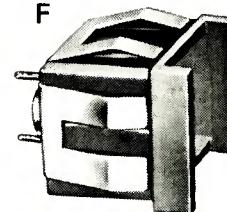

Snap-in Mtg.
Matching Indicator
w/ 3/4" x 1" Bezel
with Barrier

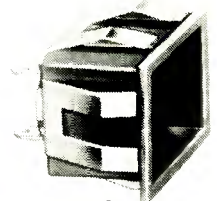

G
Snap-in Mtg.
Matching Indicator
w/ 3/4" Sq. Bezel

Illustrations Approx. 75% Actual Size

See Note 1 on page 2.

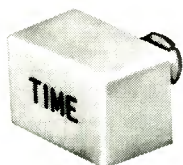

H



J

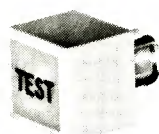

K

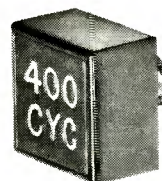

L



M

SERIES	ILLUS.	CAP SIZE	CAP SHAPE	ROTATABLE or NON-ROTATABLE		SPECIAL FEATURES	DATA IN CAT. NO.
				(R)	(N-R)		
179-	H	1/2" x 3/4"	Rectangle	R			L-210
182-	H	1/2" x 3/4"	Rectangle	N-R			L-210
183-	J	1/2"	Round	R			L-210
184-	K	1/2"	Square	N-R			L-210
185-	K	1/2"	Square	R			L-210
186-	J	1/2"	Round	N-R			L-210
187-	L	3/4"	Square	N-R			L-210
188-	M	3/4"	Round	N-R			L-210
190-	L	3/4"	Square	R			L-210
191-	M	3/4"	Round	R			L-210
192-	J	1/2"	Round			Screw-in cap	L-210
199-	N	3/4" x 1 1/2"	Rectangle	N-R			L-210
300-	O	5/8"	Square	R			L-210
301-	P	5/8"	Round	R			L-210
303-	Q	3/4" x 1"	Rectangle	N-R			L-210
304-	O	5/8"	Square	N-R			L-210
305-	P	5/8"	Round	N-R			L-210
306-	O	3/4"	Square	R			L-210
307-	O	3/4"	Square	N-R			L-210
515-0300	—	3/4" x 3/4"	Square	N-R		Kap-Kover For use with 300 & 304 Series push button caps	L-210
534-	R	3/4" x 1"	Rectangle	N-R			L-210

See Note 1 on page 2.



N

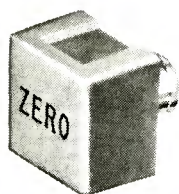

O



P

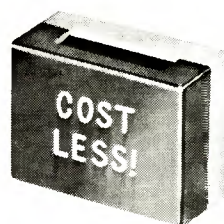

Q

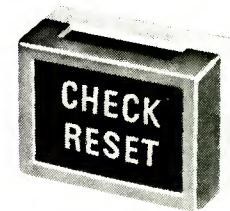

R

additional products available from Dialight

(though not described in this catalog).

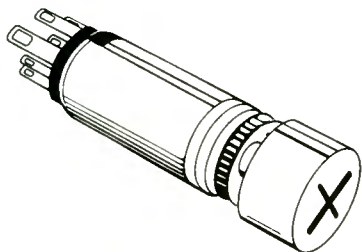

Incandescent lighted switches. . . panel mounting

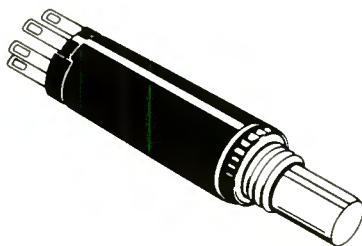

Incandescent or neon lighted switches

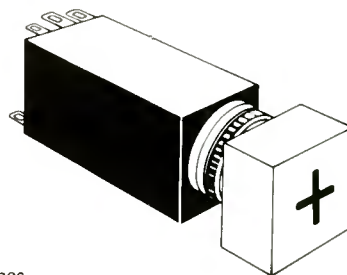

Contactless solid state switches

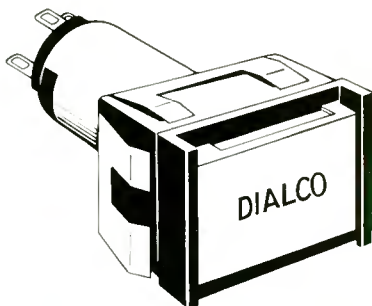

Incandescent lighted switches...snap-in mounting

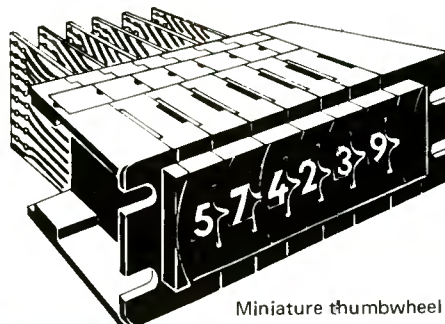

Miniature thumbwheel switches

LED DEVICES

- available are LED lamps, logic/state fault indicators, ultra-miniature plug-in cartridges and indicator lights. . . all offering solid state long life reliability. To obtain catalog, check LED PRODUCT SELECTOR GUIDE - Catalog SG731 on the enclosed reply cards.

READOUTS

Incandescent • Neon • LED

- single digit modules are available in .125", .205", .270", .300", .625" and 1.000" heights. Packaged displays and bezel mounted readout assemblies can also be obtained for quick, easy panel mounting.

To obtain catalogs, check READOUT PRODUCT SELECTOR GUIDE - Catalog SG732 on the enclosed reply cards.

SWITCHES

Incandescent • Neon • LED

for virtually any application. Dialight can give you push button switches with unlimited cap and bezel options . . . solid state switches that eliminate all mechanical switching problems. . . LED lighted switches. . . thumbwheel switches. . . switches with transistorized indicators.

To obtain data, check SWITCH catalog L-210 on the enclosed reply cards.

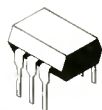

Opto-Isolators

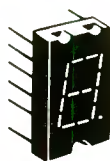
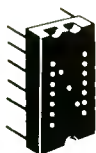

Readout modules and packages

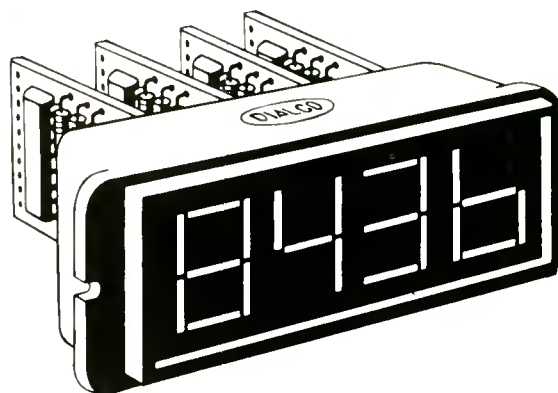
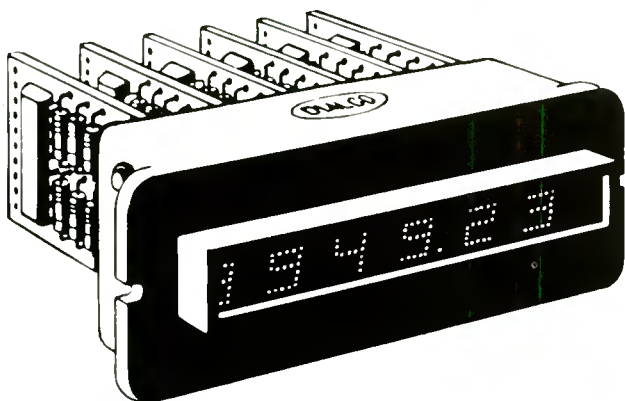
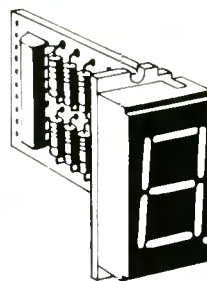
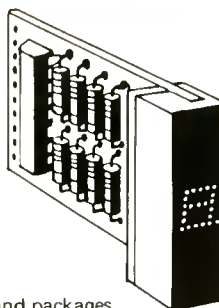

Readout assemblies

DIALIGHT

60 STEWART AVENUE • BROOKLYN, N.Y. 11237

(212) 497-7600

TWX: 710-584-5487

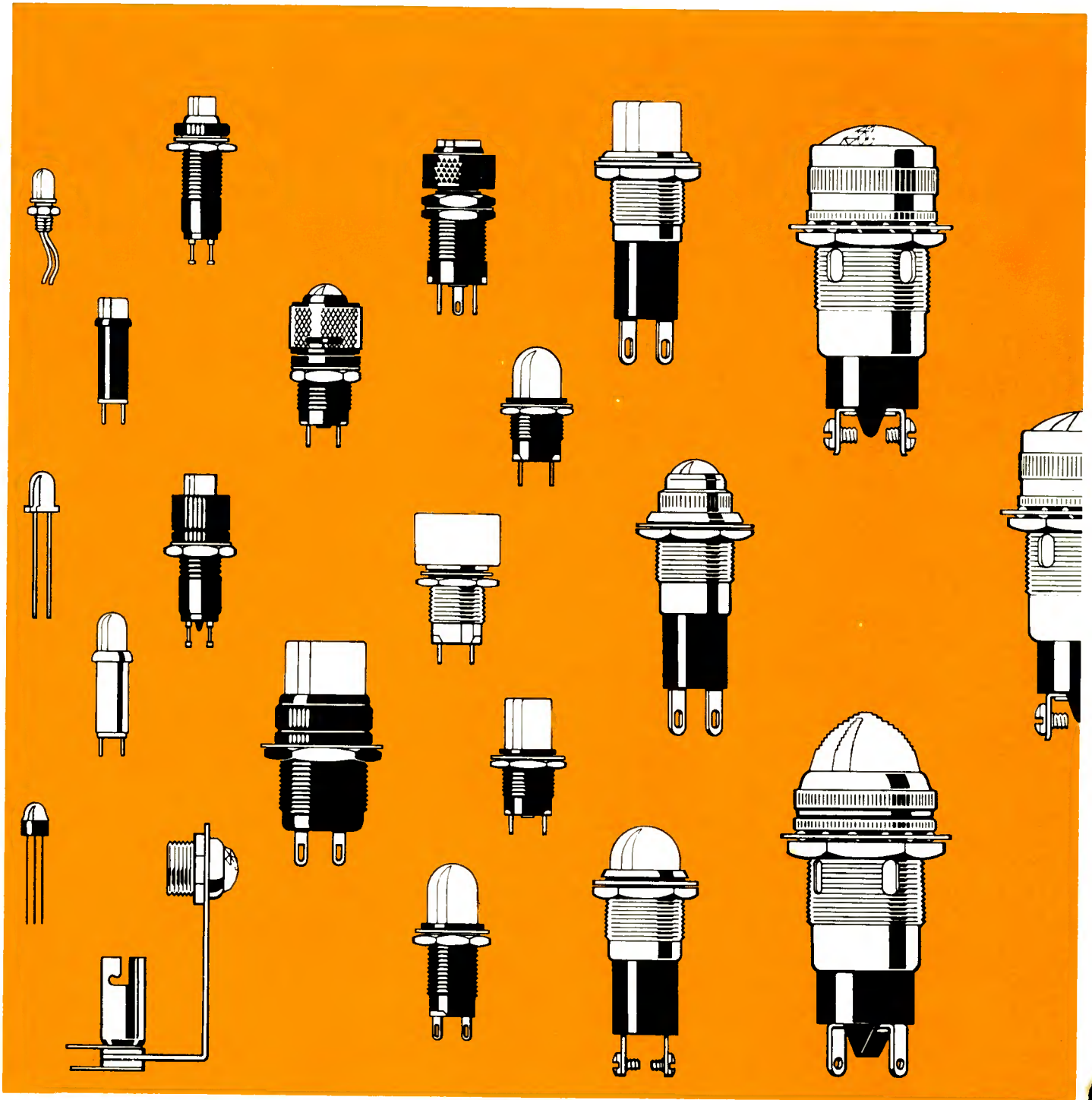

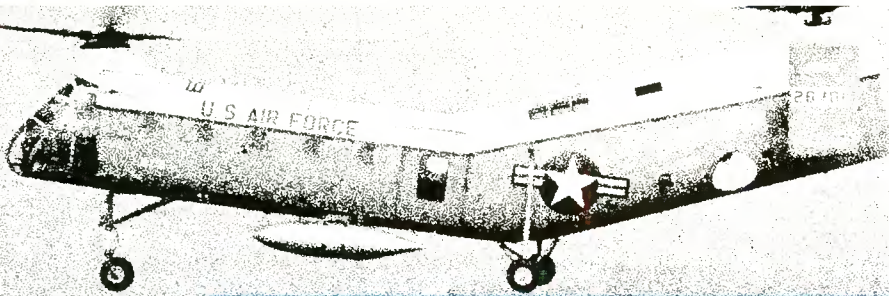

**A CROSS REFERENCE
of *DIALIGHT*
CATALOG NUMBERS
to MILITARY TYPE DESIGNATIONS
and MS DRAWINGS**

MIL-L-3661B:
"Lampholders;
Lights, Indicator;
Indicator-Light
Housings, and Lenses,
Indicator-Light"

MIL-L-7961B:
"Light, Indicator,
Press-to-Test"
MS25331-1 through 8
MS25041-1 through 11

MIL-L-6723B:
"Lights, Aircraft"
MS25257-2 through 6
MS25256-2 through 12
MS25446-2 through 7

MIL-L-7805:
"Light, Panel, Plastic
Plate Lighting"
MS26010-Revision D.

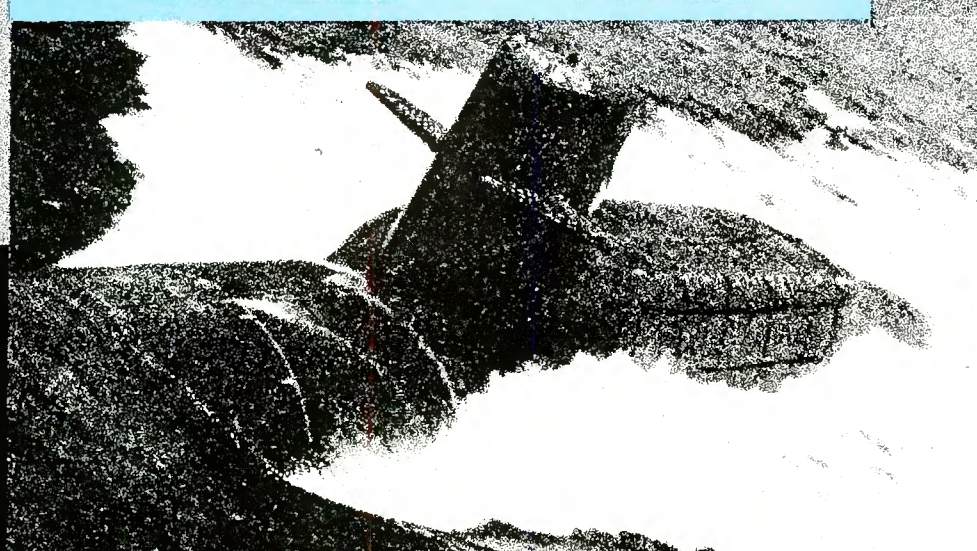



INTRODUCTION

Purpose & Scope

The purpose of this cross reference is to provide the design engineer and the buyer with a means of translating military code into commercial code and to identify the applicable military standards and certain critical description of the items specified.

This cross reference covers the general requirements for lampholders, indicator lights, indicator-light housings, and indicator-light lenses.

The "B" revision to MIL-L-3661 dated 27 March 1967 added for lens material a polycarbonate resin material (Symbol 3) with the same temperature specification as a glass lens in the "A" revision. It was intended that polycarbonate would become standard (in place of glass) and a subsequent revision of MIL - L -3661 would make glass lens inactive for new design. Amendment 3 dated 17 February 1972 deleted "glass" and "Symbol 1" which designated glass.

Dialight has deleted from this revision of the Cross-Reference all assemblies with glass lenses.

Due to the customized nature of Electronically Controlled (Transistorized) indicator lights the Military, per Notice 1, dated 20 July 1972, cancelled LHC85 and LH86. Dialight in turn has deleted these assemblies from this revision.

The B revision of MIL - L - 3661 dated 27 March 1967 had as one of its aims the consolidation under one basic set of documents the various Indicator Lights used by all of the Services. It was found there were several duplications of the same physical assemblies with both a Military Type designation and an MS Part Number. To remedy this it was agreed, at the suggestion of Dialight, that the MS Part Numbers would be made inactive as soon as appropriate paperwork could be generated. This resulted in the following:

Revision F dated 26 May 1969 made MS25256 inactive and superseded it with

the LH73/1 and LC12 Series per MIL - L -3661/5A and /12.

Revision G dated 4 June 1970 made MS25257 inactive and superseded it with LH74/1 and LC13 Series per MIL - L -3661/6 and /13.

Revision C dated 20 July 1970 made MS25446 inactive and superseded it with the LHC82/1 Series per MIL-L-3661/40.

Revision E dated 5 February 1971 made MS25010 inactive. Assemblies with the Type C Indicator Base were superseded by LH92/1 and LC34 Series per MIL-L-3661/51 and /34. No superseding assemblies were offered for those using the type A and B base.

However, due to the popularity of all of the above outlined MS assemblies and to facilitate your future procurement, we have continued to list these assemblies, the comparable Military Type designations and the Dialight Catalog Numbers.

For the purpose of this cross - reference, the following definitions apply:

1. **Lampholder:** a lampholder is an electrical device which accommodates a lamp, both electrically and mechanically, but does not provide for the use of an indicator-light lens.
2. **Indicator Light:** an indicator light is an indicator-light housing and indicator-light lens.
3. **Indicator-light housing:** an indicator-light housing is an electrical device which accommodates a lamp, both electrically and mechanically, and provides for the use of an indicator-light lens.
4. **Indicator-light lens:** an indicator-light lens is a device having a mounting means and a plastic window through which light is transmitted.

INTRODUCTION

Purpose & Scope



1.2.1 Type designation of lampholders and indicator-light housings. The type designation of lampholders and indicator-light housings shall be in the following form:

LH72	/1
Style	Type
(1.2.1.1)	(1.2.1.2)

1.2.1.1 Style. The style is identified by a two-letter symbol "LH" followed by a two-digit number.

1.2.1.2 Type. The applicable types based on circuit or mechanical parameters are identified by one or more digit numbers. The numbers shall follow and be separated from the style number by a slash mark.

1.2.2 Type designation of lenses. The type designation of lenses shall be in the following form:

LC12	B	T	2
Style	Color	Transmittance	Lens material
(1.2.2.1)	(1.2.2.2)	(1.2.2.3)	(1.2.2.4)

1.2.2.1 Style. The style is identified by a two-letter symbol "LC" followed by a two-digit number.

1.2.2.2 Color. The color of the lens shall be identified by a single letter in accordance with table I:

Table I. Color.

Symbol	Color
B ₁	Blue
C	Colorless (clear) (D and N transmittance only).
G ₁	Green (identification).
R	Red (identification).
E	Red (aviation).
W	White (aviation) (T transmittance only).
Y	Yellow (aviation).
D	Black (opaque).
S	Gray (opaque).

1. Not recommended for use with neon lamps.

1.2.2.3 Transmittance. The lens transmittance shall be identified by a single letter in accordance with table II:

Table II. Transmittance.

Symbol	Transmittance
D ₁	Diffusing ²
N	Nondiffusing
T ₁	Translucent ³
O ₁	Opaque ⁴
B ₁	Translucent/black overlay ⁵

1. Not recommended for use with neon lamps.
2. In these lenses diffusion shall be accomplished only by the surface closest to the lamp.
3. In these lenses the diffusing media shall be dispersed throughout the transmitting plastic material.
4. In these lenses no light shall be transmitted or reflected.
5. Lens, prior to black overlay, shall be translucent. Exterior viewing portion of the lens excluding any legend(s) shall be covered with a black lusterless finish.

1.2.2.4 Material. The lens material shall be identified by a one-digit number in accordance with table III:

Table III. Lens material

Symbol	Material
2	Plastic (-55°C. to +71°C.)
3	Plastic (-55°C. to +125°C.)

1.2.3 Type designation of indicator lights (non-replaceable lens type). The type designation for indicator lights with non-replaceable lens and nomenclature display types shall be in the following form:

LHC82	/1	BT2
Style	Type	(1.2.2.2
(1.2.3.1)	(1.2.1.2)	to 1.2.2.4)

1.2.3.1 Style. The style is identified by a three-letter symbol "LHC" followed by a two-digit number.



INDEX

military type designations to Dialight catalog numbers

PAGE NUMBER	MILITARY TYPE DESIGNATIONS	DIALIGHT COMPLETE ASSEMBLY NUMBERS	DIALIGHT LENS CAP NUMBERS	DIALIGHT INDICATOR LIGHT HOUSING NUMBERS
8	LC11	-----	178-0331-500	-----
8	LC12	-----	162-0931	-----
9	LC13	-----	137-0931	-----
11, 12	LC14	-----	81-0131-203	-----
11	LC15	-----	-----	-----
12	LC16	-----	-----	-----
11, 12	LC17	-----	203-0131-203	-----
11, 12	LC18	-----	204-0131-203	-----
13	LC19	-----	169-1131-203	-----
13	LC20	-----	169-1191-203	-----
14, 15	LC21	-----	51-0131-203	-----
14, 15	LC22	-----	80-0531-203	-----
14, 15	LC23	-----	209-0131-203	-----
14, 15	LC24	-----	210-0131-203	-----
8	LC25	-----	239-0331-500	-----
8	LC29	-----	162-1431	-----
7	LC30	-----	250-3531-500	-----
7	LC31	-----	253-1437-500	-----
7	LC32	-----	250-1471-500	-----
9	LC33	-----	130-0931-003	-----
10	LC34	-----	271-0111	-----
10	LC35	-----	128-0931-003	-----
10	LC36	-----	160-0131-203	-----
10	LC37	-----	161-0131-203	-----
11	LH50/1	-----	-----	372-8136-203
11	LH50/1, LC14	372-8136-0131-203	81-0131-203	372-8136-203
11	LH50/1, LC17	372-6236-0131-203	203-0131-203	372-8136-203
11	LH50/1, LC18	372-6336-0131-203	204-0131-203	372-8136-203
11	LH71/1	-----	-----	503-4634
11	LH72/1	-----	-----	503-4931
8	LH73/1	-----	-----	359-8430-09-502
8	LH73/1, LC11	360-8430-0371-502	178-0371-500	359-8430-09-502
8	LH73/1, LC12	359-8430-0971-502	162-0971	359-8430-09-502
8	LH73/1, LC29	359-8430-1471-502	162-1471	359-8430-09-502
8	LH73/2	-----	-----	362-8430-09-702
8	LH73/2, LC25	363-8430-0331-502	239-0331-500	362-8430-09-702
9	LH74/1	-----	-----	361-8836-09-552
9	LH74/1, LC13	361-8836-0931-552	137-0931	361-8836-09-552
9	LH74/2	-----	-----	361-8864-09-522
9	LH74/2, LC13	361-8864-0931-522	137-0931	361-8864-09-522
9	LH74/3	-----	-----	364-8836-09-752
9	LH74/4	-----	-----	364-8864-09-722
12	LH76/1	-----	-----	373-0408-01-273
12	LH76/1, LC14	373-0408-0131-273	81-0131-203	373-0408-01-273
12	LH76/1, LC17	375-0408-0131-273	203-0131-203	373-0408-01-273
12	LH76/1, LC18	376-0408-0131-273	204-0131-203	373-0408-01-273
12	LH76/2	-----	-----	373-0463-01-223
12	LH76/2, LC14	373-0463-0131-223	81-0131-203	373-0463-01-223
12	LH76/2, LC17	375-0463-0131-223	203-0131-203	373-0463-01-223
12	LH76/2, LC18	376-0463-0131-223	204-0131-203	373-0463-01-223
12	LH76/3	-----	-----	373-0410-01-203
12	LH76/3, LC14	373-0410-0131-203	81-0131-203	373-0410-01-203
12	LH76/3, LC17	375-0410-0131-203	203-0131-203	373-0410-01-203
12	LH76/3, LC18	376-0410-0131-203	204-0131-203	373-0410-01-203
13	LH77/1	-----	-----	377-0408-11-273
13	LH77/1, LC19	377-0408-1131-273	169-1131-203	377-0408-11-273
13	LH77/1, LC20	377-0408-1191-273	169-1191-203	377-0408-11-273
13	LH77/2	-----	-----	377-0463-11-223
13	LH77/2, LC19	377-0463-1131-223	169-1131-203	377-0463-11-223
13	LH77/2, LC20	377-0463-1191-223	169-1191-203	377-0463-11-223

Government Type Designations for lens cap assemblies do not include lens color, finish or material and the Dialight Part Numbers indicate red lens (except LH87). Specific requirements will be found on appropriate pages.

INDEX

military type designations to Dialight catalog numbers



PAGE NUMBER	MILITARY TYPE DESIGNATIONS	DIALIGHT COMPLETE ASSEMBLY NUMBERS	DIALIGHT LENS CAP NUMBERS	DIALIGHT INDICATOR LIGHT HOUSING NUMBERS
13	LH77/3	-----	-----	377-0410-11-203
13	LH77/3, LC19	377-0410-1131-203	169-1131-203	377-0410-11-203
13	LH77/3, LC20	377-0410-1191-203	169-1191-203	377-0410-11-203
14	LH79/1	-----	-----	378-3404-01-203
14	LH79/1, LC21	378-3404-0131-203	51-0131-203	378-3404-01-203
14	LH79/1, LC22	379-3404-0531-203	80-0531-203	378-3404-01-203
14	LH79/1, LC23	380-3404-0131-203	209-0131-203	378-3404-01-203
14	LH79/1, LC24	381-3404-0131-203	210-0131-203	378-3404-01-203
15	LH80/1	-----	-----	378-3402-01-203
15	LH80/1, LC21	378-3402-0131-203	51-0131-203	378-3402-01-203
15	LH80/1, LC22	379-3402-0531-203	80-0531-203	378-3402-01-203
15	LH80/1, LC23	380-3402-0131-203	209-0131-203	378-3402-01-203
16	LH80/1, LC24	381-3402-0131-203	210-0131-203	378-3402-01-203
16	LHC81/1	-----	-----	520-1291-03-001
16	LHC81/2	-----	-----	520-1291-03-002
16	LHC81/3	-----	-----	520-1291-03-003
16	LHC81/4	-----	-----	520-1291-03-004
16	LHC81/5	-----	-----	520-1291-03-005
16	LHC81/6	-----	-----	520-1291-03-006
16	LHC81/7	-----	-----	520-1291-03-007
16	LHC81/8	-----	-----	520-1291-03-008
16	LHC81/9	-----	-----	520-1291-03-009
16	LHC81/10	-----	-----	520-1291-03-010
16	LHC81/11	-----	-----	520-1292-03-001
16	LHC81/12	-----	-----	520-1292-03-002
16	LHC81/13	-----	-----	520-1292-03-003
16	LHC81/14	-----	-----	520-1292-03-004
16	LHC81/15	-----	-----	520-1292-03-005
16	LHC81/16	-----	-----	520-1292-03-006
16	LHC81/17	-----	-----	520-1292-03-007
16	LHC81/18	-----	-----	520-1292-03-008
16	LHC81/19	-----	-----	520-1292-03-009
16	LHC81/20	-----	-----	520-1292-03-010
16	LHC82/1	252-9951-0971	-----	-----
16	LHC82/2	236-9951-0971	-----	-----
7	LH87/1	-----	-----	365-6939-14-504
7	LH87/1, LC31	365-6939-1437-504	253-1437-500	365-6939-14-504
9	LH88/1	-----	-----	366-8836-09-553
9	LH88/1, LC33	366-8836-0931-553	130-0931-003	366-8836-09-553
9	LH88/2	-----	-----	366-8864-09-523
9	LH88/2, LC33	366-8864-0931-523	130-0931-003	366-8864-09-523
10	LH89/1	-----	-----	367-8430-09-503
10	LH89/1, LC35	367-8430-0931-503	128-0931-003	367-8430-09-503
10	LH89/1, LC36	368-8430-0131-203	160-0131-203	367-8430-09-503
10	LH89/1, LC37	369-8430-0131-203	161-0131-203	367-8430-09-503
7	LH90/1	-----	-----	370-8738-504
7	LH90/2	-----	-----	371-8738-14-504
7	LH90/2, LC30	371-8738-3531-504	250-3531-500	371-8738-14-504
7	LH90/2, LC32	371-8738-1471-504	250-1471-500	371-8738-14-504
7	LH90/3	-----	-----	371-8760-14-504
7	LH90/3, LC30	371-8760-3531-504	250-3531-500	371-8760-14-504
10	LH92/1	-----	-----	271-8430-702
10	LH92/1, LC34	271-8430-0111-702	271-0111	271-8430-702
6	MS18235-1	507-3909-1471-600	-----	-----
6	MS18235-2	507-3914-1471-600	-----	-----
6	MS18235-3	507-3918-1471-600	-----	-----
6	MS18236-1	507-5338-0931-630	-----	-----
6	MS18236-2	507-5337-0931-670	-----	-----
6	MS18237-1	507-5338-1531-630	-----	-----
6	MS18237-2	507-5337-1531-670	-----	-----
6	MS18238-1	507-6022-1437-600	-----	-----
6	MS18238-2	507-6023-1437-600	-----	-----



The lamp cartridges described below are intended for use with base assemblies listed in this table. Data is furnished for base assemblies on the facing page.

INDICATOR LIGHT HOUSING	
TYPE DESIGNATION	DIALIGHT CATALOG NO.
LH87/1	365-6939-14-504
LH90/1	370-8738-504
LH90/2*†	371-8738-14-504
LH90/3■	371-8760-14-504

cross reference to military and ms numbers MIL-L-3661B

INCANDESCENT



507-3909-1471-600
MS18235-1RT

LAMP CARTRIDGE	VOLTS	MA
MS18235-1	6.3	200
MS18235-2	14	80
MS18235-3	28	40

LAMP CARTRIDGE DESCRIPTION			
MILITARY STD. DRAWING NO.	DIALIGHT CATALOG NO.	FINISH	COLOR
MS18235-1RT	507-3909-1471-600	Trans'l.	Red
MS18235-1GT	507-3909-1472-600	Trans'l.	Green
MS18235-1YT	507-3909-1473-600	Trans'l.	Yellow (Amber)
MS18235-1BT	507-3909-1474-600	Trans'l.	Blue
MS18235-1WT	507-3909-1475-600	Trans'l.	White
MS18235-1CN*	507-3909-1437-600	Non-Diff.	Colorless (Clear)
MS18235-2RT	507-3914-1471-600	Trans'l.	Red
MS18235-2GT	507-3914-1472-600	Trans'l.	Green
MS18235-2YT	507-3914-1473-600	Trans'l.	Yellow (Amber)
MS18235-2BT	507-3914-1474-600	Trans'l.	Blue
MS18235-2WT	507-3914-1475-600	Trans'l.	White
MS18235-2CN*	507-3914-1437-600	Non-Diff.	Colorless (Clear)
MS18235-3RT	507-3918-1471-600	Trans'l.	Red
MS18235-3GT	507-3918-1472-600	Trans'l.	Green
MS18235-3YT	507-3918-1473-600	Trans'l.	Yellow (Amber)
MS18235-3BT	507-3918-1474-600	Trans'l.	Blue
MS18235-3WT	507-3918-1475-600	Trans'l.	White
MS18235-3CN*	507-3918-1437-600	Non-Diff.	Colorless (Clear)

* Only incandescent lamp cartridges with clear (colorless) lens (-1CN, -2CN, -3CN) should be used with LH90/2 base assembly, when combined with LC30 or LC32 lens cap.

NEON



507-5338-0931-630
MS18236-1RN

LAMP CARTRIDGE	VOLTS	RESISTOR
MS18236-1	110-125AC	33K
MS18236-2	105-125AC-DC	100K



507-5338-1531-630
MS18237-1RN

LAMP CARTRIDGE	VOLTS	RESISTOR
MS18237-1	110-125AC	33K
MS18237-2	105-125AC-DC	100K

MS18236-1RN	507-5338-0931-630	Non-Diff.	Red
MS18236-1YN	507-5338-0933-630	Non-Diff.	Yellow (Amber)
MS18236-1WT	507-5338-0935-630	Trans'l.	White
MS18236-1CN	507-5338-0937-630	Non-Diff.	Colorless (Clear)
MS18236-2RN	507-5337-0931-670	Non-Diff.	Red
MS18236-2YN	507-5337-0933-670	Non-Diff.	Yellow (Amber)
MS18236-2WT	507-5337-0935-670	Trans'l.	White
MS18236-2CN	507-5337-0937-670	Non-Diff.	Colorless (Clear)
MS18237-1RN	507-5338-1531-630	Non-Diff.	Red
MS18237-1YN	507-5338-1533-630	Non-Diff.	Yellow (Amber)
MS18237-1WT	507-5338-1535-630	Trans'l.	White
MS18237-1CN	507-5338-1537-630	Non-Diff.	Colorless
MS18237-2RN	507-5337-1531-670	Non-Diff.	Red
MS18237-2YN	507-5337-1533-670	Non-Diff.	Yellow (Amber)
MS18237-2WT	507-5337-1535-670	Trans'l.	White
MS18237-2CN	507-5337-1537-670	Non-Diff.	Colorless (Clear)

† There are no lens cap assemblies with MS part number designations for use with LH90/2 when the light housing is used with neon lamp cartridges.

For use with LH90/3 and LC30 Base and Lens Cap Assemblies only.

INCANDESCENT



507-6022-1437-600
MS18238-1

LAMP CARTRIDGE	VOLTS	MA
MS18238-1	48	53
MS18238-2	60	50

**MS18238-1	507-6022-1437-600	Non-Diff.	Colorless (Clear)
**MS18238-2	507-6023-1437-600	Non-Diff.	Colorless (Clear)

** This series is not supplied with colored lens, since the glass envelop of the lamp acts as a lens.

■ Accommodates MS18238 lamp cartridge only

The lamp cartridge will be marked with the basic MS number only regardless of lens color. They will also be marked with basic Dialight catalog number, voltage and ampere rating in cases of Incandescent cartridges or resistance value in cases of Neon cartridges. Examples:

DIALCO 507-3909 6.3V 200 ma. MS18235-1	DIALCO 507-5338 33K MS18236-1	DIALCO 507-5338 33K MS18237-1	DIALCO 507-6022 48V 53 ma. MS18238-1
---	--	--	---



cross reference to military and ms numbers MIL-L-3661B

INDICATOR LIGHT HOUSING	
TYPE DESIGNATION	DIALIGHT CATALOG NO.
**LH90/1	370-8738-504
**LH90/2†	371-8738-14-504
**LH90/3†	371-8760-14-504

LENS DESCRIPTION			
TYPE DESIGNATION	DIALIGHT CATALOG NO.	FINISH	COLOR
LC30RN3	250-3531-500	Non-Diff.	Red
LC30GN3	250-3532-500	Non-Diff.	Green
LC30YN3	250-3533-500	Non-Diff.	Yellow (Amber)
LC30BN3	250-3534-500	Non-Diff.	Blue
LC30WT3	250-3535-500	Non-Diff.	White
LC32RT2	250-1471-500	Translucent	Red
LC32GT2	250-1472-500	Translucent	Green
LC32YT2	250-1473-500	Translucent	Yellow (Amber)
LC32BT2	250-1474-500	Translucent	Blue
LC32WT2	250-1475-500	Translucent	White

** See cylindrical plug-in lamp cartridges, on facing page.
† No collar is furnished.

INDICATOR LIGHT HOUSING	
TYPE DESIGNATION	DIALIGHT CATALOG NO.
LH87/1	365-6939-14-504

LENS DESCRIPTION			
TYPE DESIGNATION	DIALIGHT CATALOG NO.	FINISH	COLOR
LC31WT2	253-1435-500	Translucent	White
LC31CN2	253-1437-500	Non-Diff.	Colorless (Clear)



370-8738-504
LH90/1



371-8738-14-504 LH90/2
371-8760-14-504 LH90/3



250-1471-500
LC32

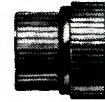

250-3531-500
LC30



371-8738-1471-504
LH90/2, LC32

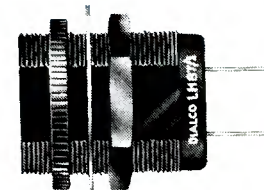
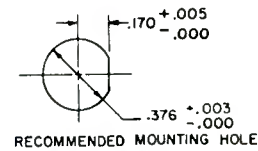

365-6939-14-504
LH87/1



253-1437-500
LC31

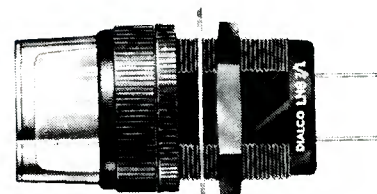

365-6939-1437-504
LH87/1, LC31

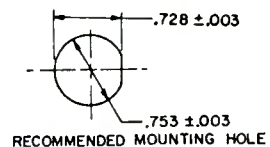

cross reference to military and ms numbers MIL-L-3661B

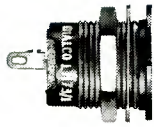

359-8430-09-502
LH73/1

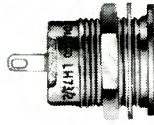

362-8430-09-702
LH73/2

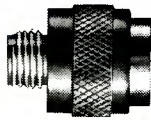

178-0331-500
LC11

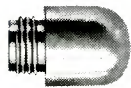

162-0931
LC12

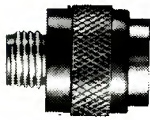

239-0331-500
LC25

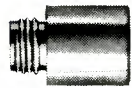

162-1431
LC29



359-8430-0971-502
LH73/1, LC12

Lamp accommodation: T-1 3/4 bulb, mid-gt flanged base, incandescent.

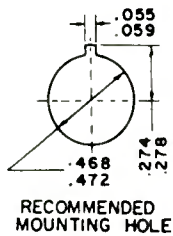

INDICATOR LIGHT HOUSING	
TYPE DESIGNATION	DIALIGHT CATALOG NO.
LH73/1††	359-8430-09-502
LH73/2◇◇	362-8430-09-702

LENS DESCRIPTION			
TYPE DESIGNATION	DIALIGHT CATALOG NO.	FINISH	COLOR
LC11RN2	178-0331-500	Non Diff.	Red
LC11GN2	178-0332-500	Non Diff.	Green
LC11YN2	178-0333-500	Non Diff.	Yellow (Amber)
LC11BN2	178-0334-500	Non Diff.	Blue
LC11CN2	178-0337-500	Non Diff.	Colorless (Clear)
LC11RT2	178-0371-500	Translucent	Red
LC11GT2	178-0372-500	Translucent	Green
LC11YT2	178-0373-500	Translucent	Yellow (Amber)
LC11BT2	178-0374-500	Translucent	Blue
LC11WT2	178-0375-500	Translucent	White
LC11RB2**	178-5771-500	Translucent	Red
LC11GB2**	178-5772-500	Translucent	Green
LC11YB2**	178-5773-500	Translucent	Yellow (Amber)
LC11BB2**	178-5774-500	Translucent	Blue
LC11WB2**	178-5775-500	Translucent	White
LC12RN2	162-0931	Non Diff.	Red
LC12GN2	162-0932	Non Diff.	Green
LC12YN2	162-0933	Non Diff.	Yellow (Amber)
LC12BN2	162-0934	Non Diff.	Blue
LC12CN2	162-0937	Non Diff.	Colorless (Clear)
LC12RT2	162-0971	Translucent	Red
LC12GT2	162-0972	Translucent	Green
LC12YT2	162-0973	Translucent	Yellow (Amber)
LC12BT2	162-0974	Translucent	Blue
LC12WT2	162-0975	Translucent	White
LC25RN2	239-0331-500	Non Diff.	Red
LC25GN2	239-0332-500	Non Diff.	Green
LC25YN2	239-0333-500	Non Diff.	Yellow (Amber)
LC25BN2	239-0334-500	Non Diff.	Blue
LC25CN2	239-0337-500	Non Diff.	Colorless (Clear)
LC25RT2	239-0371-500	Translucent	Red
LC25GT2	239-0372-500	Translucent	Green
LC25YT2	239-0373-500	Translucent	Yellow (Amber)
LC25BT2	239-0374-500	Translucent	Blue
LC25WT2	239-0375-500	Translucent	White
LC29RN2	162-1431	Non Diff.	Red
LC29GN2	162-1432	Non Diff.	Green
LC29YN2	162-1433	Non Diff.	Yellow (Amber)
LC29BN2	162-1434	Non Diff.	Blue
LC29CN2	162-1437	Non Diff.	Colorless (Clear)
LC29RT2	162-1471	Translucent	Red
LC29GT2	162-1472	Translucent	Green
LC29YT2	162-1473	Translucent	Yellow (Amber)
LC29BT2	162-1474	Translucent	Blue
LC29WT2	162-1475	Translucent	White

†† For use with LC11, LC12 and LC29 lens caps only.

◇◇ For use with LC25, LC26 and LC27 lens caps only.

** To be used only to enable the engraving of color legends when required. Only the legend will show in color. The black color is lusterless.



cross reference to military and ms numbers MIL-L-3661B

INDICATOR LIGHT HOUSING	
TYPE DESIGNATION	DIALIGHT CATALOG NO.
LH74/1*	361-8836-09-552
LH74/2*	361-8864-09-522
LH74/3†	364-8836-09-752
LH74/4†	364-8864-09-722

LENS DESCRIPTION

TYPE DESIGNATION	DIALIGHT CATALOG NO.	FINISH	COLOR
LC13RN2	137-0931	Non Diff.	Red
LC13YN2	137-0933	Non Diff.	Yellow (Amber)
LC13WT2	137-0935	Translucent	White □
LC13CN2	137-0937	Non Diff.	Colorless (Clear)

- The transmittance shall be suitable for use with a neon lamp.
- * For use with LC13 Lens Cap Assemblies only.
- † For use with LC28 Lens Cap Assemblies only.

Lamp accommodation:
Neon C7A (MS25252-NE-2D)
or Neon C9A (MS25252-NE-2J).

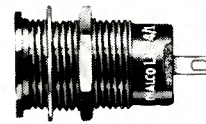

361-8836-09-552 LH74/1
361-8864-09-522 LH74/2
364-8836-09-752 LH74/3
364-8864-09-722 LH74/4



137-0931
LC13

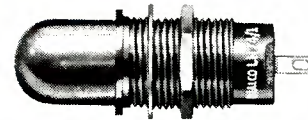

361-8836-0931-552
LH74/1, LC13

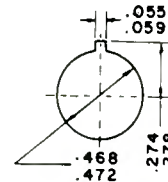

RECOMMENDED
MOUNTING HOLE

INDICATOR LIGHT HOUSING	
TYPE DESIGNATION	DIALIGHT CATALOG NO.
LH88/1	366-8836-09-553
LH88/2	366-8864-09-523

LENS DESCRIPTION

TYPE DESIGNATION	DIALIGHT CATALOG NO.	FINISH	COLOR
LC33RN2	130-0931-003	Non Diff.	Red
LC33YN2	130-0933-003	Non Diff.	Yellow (Amber)
LC33WT2	130-0935-003	Translucent	White *
LC33CN2	130-0937-003	Non Diff.	Colorless (Clear)

- *Transmittance suitable for use with neon lamp.
- Lamp accommodation: Neon C7A (MS25252-NE-2D)
or Neon C9A (MS25252-NE-2J).



366-8836-09-553
LH88/1
366-8864-09-523
LH88/2

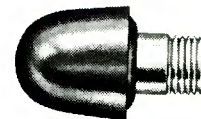

130-0931-003
LC33

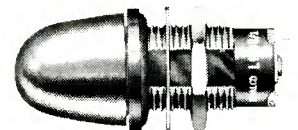

366-8836-0931-553
LH88/1, LC33
366-8864-0931-523
LH88/2, LC33

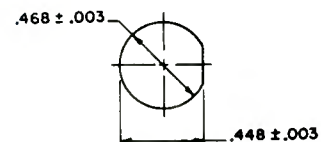

RECOMMENDED
MOUNTING HOLE



cross reference to military and ms numbers MIL-L-3661B



271-8430-702
LH92/1

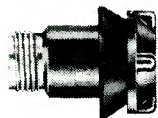

271-0111
LC34



271-8430-0111-702
LH92/1, LC34

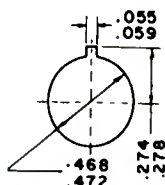

RECOMMENDED
MOUNTING HOLE

INDICATOR LIGHT HOUSING	
TYPE DESIGNATION	DIALIGHT CATALOG NO.
LH92/1	271-8430-702

TYPE DESIGNATION	DIALIGHT CATALOG NO.	FILTER COLOR - TRANSMITTANCE	CAP ASSEMBLY TOP COLOR	LIGHT SEAL WASHER COLOR
LC34EN2/DO2	271-0111	Red Non Diff	Black	Black
LC34CN2/DO2	271-0171	Colorless Non-Diff	Black	Black
LC34EN2/EN2	271-3111	Red Non Diff.	Red	Black
LC34EN2/SO2	271-0212	Red Non Diff.	Gray	Gray
LC34CN2/SO2	271-0272	Colorless Non Diff.	Gray	Gray

Lamp accommodation: T-1 3/4 bulb, midget flanged base, incandescent.



367-8430-09-503
LH89/1

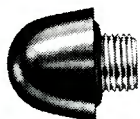

128-0931-003
LC35

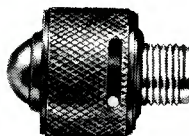

160-0131-203
LC36
161-0131-203
LC37

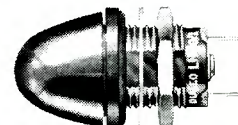

367-8430-0931-503
LH89/1, LC35

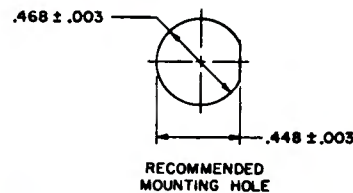

INDICATOR LIGHT HOUSING	
TYPE DESIGNATION	DIALIGHT CATALOG NO.
LH89/1	367-8430-09-503

LENS DESCRIPTION			
TYPE DESIGNATION	DIALIGHT CATALOG NO.	FINISH	COLOR
LC35RN2	128-0931-003	Non Diff	Red
LC35GN2	128-0932-003	Non Diff	Green
LC35YN2	128-0933-003	Non Diff	Yellow (Amber)
LC35BN2	128-0934-003	Non Diff	Blue
LC35CN2	128-0937-003	Non Diff	Colorless (Clear)
LC35RT2	128-0971-003	Translucent	Red
LC35GT2	128-0972-003	Translucent	Green
LC35YT2	128-0973-003	Translucent	Yellow (Amber)
LC35BT2	128-0974-003	Translucent	Blue
LC35WT2	128-0975-003	Translucent	White

LENS DESCRIPTION			
TYPE DESIGNATION	DIALIGHT CATALOG NO.	FINISH	COLOR
LC36RD2	160-0111-203	Diffusing	Red
LC36GD2	160-0112-203	Diffusing	Green
LC36YD2	160-0113-203	Diffusing	Yellow (Amber)
LC36BD2	160-0114-203	Diffusing	Blue
LC36CD2	160-0117-203	Diffusing	Colorless (Clear)
LC37RD2	161-0111-203	Diffusing	Red
LC37GD2	161-0112-203	Diffusing	Green
LC37YD2	161-0113-203	Diffusing	Yellow (Amber)
LC37BD2	161-0114-203	Diffusing	Blue
LC37CD2	161-0117-203	Diffusing	Colorless (Clear)

Lamp accommodation: T-1 3/4 bulb, midget flanged base, incandescent.

cross reference to military and ms numbers MIL-L-3661B

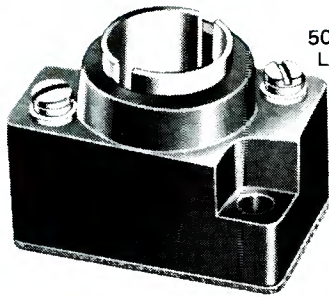

503-4634
LH71/1

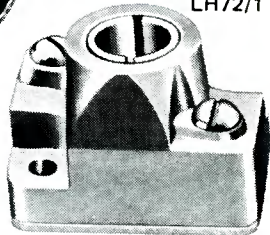

503-4931
LH72/1

Lamp accommodation:
S6 and C7 bulb, double
contact, candelabra,
bayonet base, incandes-
cent, 125V maximum.

Lamp accommodation:
T-3 1/4 bulb, mini-
ature bayonet base,
incandescent.

INDICATOR LIGHT HOUSING	
TYPE DESIGNATION	DIALIGHT CATALOG NO.
LH71/1	503-4634
LH72/1	503-4931

INDICATOR LIGHT HOUSING	
TYPE DESIGNATION	DIALIGHT CATALOG NO.
LH50/1	372-8136-203

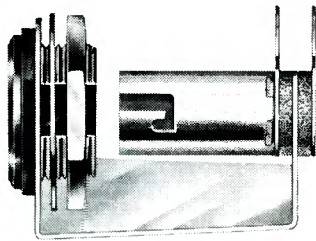

372-8136-203
LH50/1

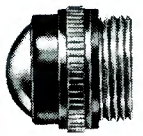

81-0131-203
LC14

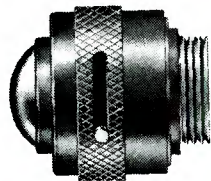

203-0131-203 LC17
204-0131-203 LC18

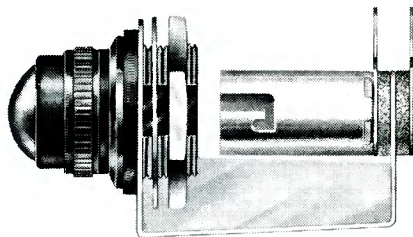

372-8136-0131-203
LH50/1, LC14

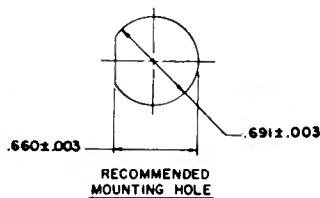

Lamp accommodation: T-3 1/4 bulb,
miniature bayonet base, incandescent.

LENS DESCRIPTION			
TYPE DESIGNATION	DIALIGHT CATALOG NO.	FINISH	COLOR
LC14RN3	81-0131-203	Non-Diff.	Red
LC14GN3	81-0132-203	Non-Diff.	Green
LC14YN3	81-0133-203	Non-Diff.	Yellow (Amber)
LC14BN3	81-0134-203	Non-Diff.	Blue
LC14WT3	81-0135-203	Translucent	White
LC14CN3	81-0137-203	Non-Diff.	Colorless (Clear)
LC14RD3	81-0111-203	Diffusing	Red
LC14GD3	81-0112-203	Diffusing	Green
LC14YD3	81-0113-203	Diffusing	Yellow (Amber)
LC14BD3	81-0114-203	Diffusing	Blue
LC14CD3	81-0117-203	Diffusing	Colorless (Clear)

Note: The LC15 Indicator Light Lens has not been illustrated or listed. It is not recommended for use with the LH50/1 Indicator Light Housing.



INDICATOR LIGHT HOUSING	
TYPE DESIGNATION	DIALIGHT CATALOG NO.
LH76/1	373-0408-01-273
LH76/2	373-0463-01-223
LH76/3	373-0410-01-203

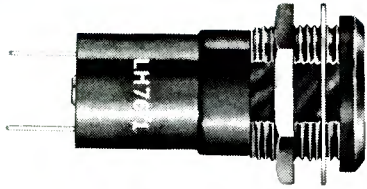

373-0408-01-273 LH76/1
 373-0463-01-223 LH76/2
 373-0410-01-203 LH76/3

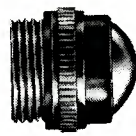

81-0131-203
 LC14

(see preceding page)

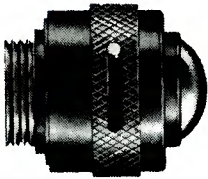

203-0131-203
 LC17

204-0131-203
 LC18

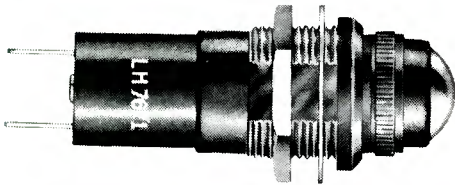

373-0408-0131-273
 LH76/1 LC14

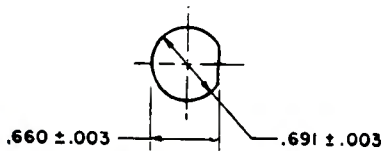

RECOMMENDED MOUNTING HOLE

Lamp accommodation: For LH76/1 – T- 3 1/4 bulb, miniature bayonet base, neon, B1A (NE-51). For LH76/2 – T- 3 1/4 bulb, miniature bayonet base, neon, B2A (NE-51H). For LH76/3 – T- 3 1/4 bulb, miniature bayonet base, incandescent.

LENS DESCRIPTION			
TYPE DESIGNATION	DIALIGHT CATALOG NO.	FINISH	COLOR
LC17RN3	203-0131-203	Non-Diff.	Red
LC17GN3*	203-0132-203	Non-Diff.	Green
LC17YN3	203-0133-203	Non-Diff.	Yellow (Amber)
LC17BN3*	203-0134-203	Non-Diff.	Blue
LC17WT3*	203-0135-203	Translucent	White
LC17CN3	203-0137-203	Non-Diff.	Colorless (Clear)
LC17RD3	203-0111-203	Diffusing	Red
LC17GD3*	203-0112-203	Diffusing	Green
LC17YD3	203-0113-203	Diffusing	Yellow (Amber)
LC17BD3*	203-0114-203	Diffusing	Blue
LC17CD3	203-0117-203	Diffusing	Colorless (Clear)
LC18RN3	204-0131-203	Non-Diff.	Red
LC18GN3*	204-0132-203	Non-Diff.	Green
LC18YN3	204-0133-203	Non-Diff.	Yellow (Amber)
LC18BN3*	204-0134-203	Non-Diff.	Blue
LC18CN3	204-0137-203	Non-Diff.	Colorless (Clear)
LC18RD3	204-0111-203	Diffusing	Red
LC18GD3*	204-0112-203	Diffusing	Green
LC18YD3	204-0113-203	Diffusing	Yellow (Amber)
LC18BD3*	204-0114-203	Diffusing	Blue
LC18CD3	204-0117-203	Diffusing	Colorless (Clear)

* Not recommended for use with neon lamps.

Note: Neither the LC15 nor LC16 Indicator Light Lenses have been illustrated or listed. We do not recommend their use with the LH76/1, 2 and 3 Indicator Light Housings. The LH77/1, 2 and 3 Indicator Light Housings with LC19 or LC20 Indicator Light Lenses (shown on facing page) should be used. Their design permits best wide angle viewing.



cross reference to
military and ms numbers
MIL-L-3661B

INDICATOR LIGHT HOUSING	
TYPE DESIGNATION	DIALIGHT CATALOG NO.
LH77/1	377-0408-11-273
LH77/2	377-0463-11-223
LH77/3	377-0410-11-203

LENS DESCRIPTION			
TYPE DESIGNATION	DIALIGHT CATALOG NO.	FINISH	COLOR
LC19RN3	169-1131-203	Non Diff.	Red
LC19GN3	169-1132-203	Non-Diff.	Green
LC19YN3	169-1133-203	Non Diff.	Yellow (Amber)
LC19BN3	169-1134-203	Non Diff.	Blue
LC19CN3	169-1137-203	Non Diff.	Colorless (Clear)
LC19RD3	169-1111-203	Diffusing	Red
LC19GD3	169-1112-203	Diffusing	Green
LC19YD3	169-1113-203	Diffusing	Yellow (Amber)
LC19BD3	169-1114-203	Diffusing	Blue
LC19WT3	169-1135-203	Translucent	White
LC19CD3	169-1117-203	Diffusing	Colorless (Clear)
LC20RN3	169-1191-203	Non Diff.	Red
LC20GN3	169-1192-203	Non Diff.	Green
LC20YN3	169-1193-203	Non-Diff.	Yellow (Amber)
LC20BN3	169-1194-203	Non Diff.	Blue
LC20WT3	169-1195-203	Translucent	White
LC20CN3	169-1197-203	Non Diff.	Colorless (Clear)

Lamp accommodation: For LH77/1 – T- 3 1/4 bulb, miniature bayonet base, neon, B1A (NE-51). For LH77/2 – T- 3 1/4 bulb, miniature bayonet base, neon, B2A (NE-51H). For LH77/3 – T- 3 1/4 bulb, miniature bayonet base, incandescent.

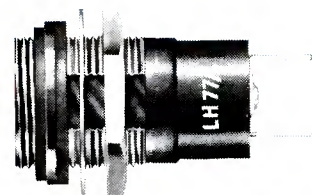

377-0408-11-273 LH77/1
377-0463-11-223 LH77/2
377-0410-11-203 LH77/3

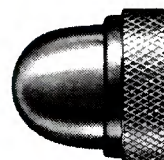

169-1131-203
LC19

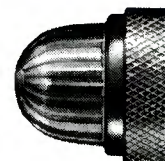

169-1191-203
LC20

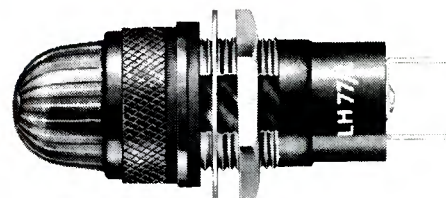

377-0408-1191-273
LH77/1, LC20

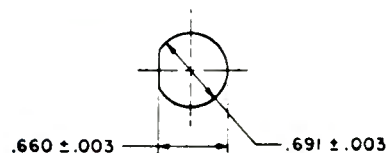

RECOMMENDED MOUNTING HOLE

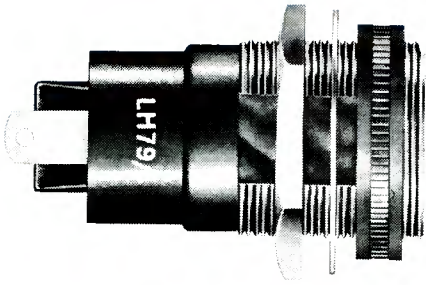

378-3404-01-203 LH79/1

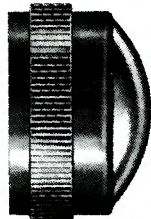

51-0131-203
LC21

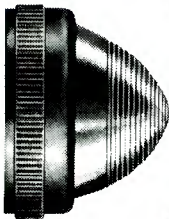

80-0531-203
LC22

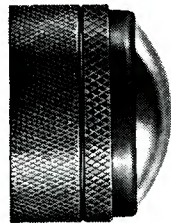

209-0131-203 LC23
210-0131-203 LC24

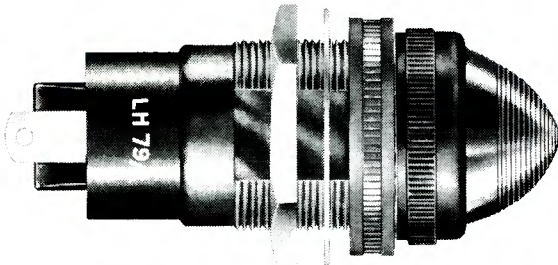

378-3404-0531-203 LH79/1, LC22

INDICATOR LIGHT HOUSING	
TYPE DESIGNATION	DIALIGHT CATALOG NO.
LH79/1	378-3404-01-203
LH80/1	378-3402-01-203

LENS DESCRIPTION			
TYPE DESIGNATION	DIALIGHT CATALOG NO.	FINISH	COLOR
LC21RN3	51-0131-203	Non-Diff.	Red
LC21GN3	51-0132-203	Non-Diff.	Green
LC21YN3	51-0133-203	Non-Diff.	Yellow (Amber)
LC21BN3	51-0134-203	Non-Diff.	Blue
LC21WT3	51-0135-203	Translucent	White
LC21CN3	51-0137-203	Non-Diff.	Colorless (Clear)
LC21RD3	51-0111-203	Diffusing	Red
LC21GD3	51-0112-203	Diffusing	Green
LC21YD3	51-0113-203	Diffusing	Yellow (Amber)
LC21BD3	51-0114-203	Diffusing	Blue
LC21CD3	51-0117-203	Diffusing	Colorless (Clear)
LC22RN3	80-0531-203	Non-Diff.	Red
LC22GN3	80-0532-203	Non-Diff.	Green
LC22YN3	80-0533-203	Non-Diff.	Yellow (Amber)
LC22BN3	80-0534-203	Non-Diff.	Blue
LC22WT3	80-0535-203	Translucent	White
LC22CN3	80-0537-203	Non-Diff.	Colorless (Clear)
LC22RD3	80-0511-203	Diffusing	Red
LC22GD3	80-0512-203	Diffusing	Green
LC22YD3	80-0513-203	Diffusing	Yellow (Amber)
LC22BD3	80-0514-203	Diffusing	Blue
LC22CD3	80-0517-203	Diffusing	Colorless (Clear)

Listing continued on following page

**cross reference to
military and ms numbers
MIL-L-3661B**

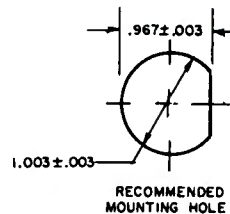

Lamp accommodation: G-6 bulb, double-contact, candelabra, bayonet base, incandescent.



cross reference to military and ms numbers MIL-L-3661B

This listing continued from preceding page

LENS DESCRIPTION			
TYPE DESIGNATION	DIALIGHT CATALOG NO.	FINISH	COLOR
LC23RN3	209-0131-203	Non-Diff.	Red
LC23GN3	209-0132-203	Non-Diff.	Green
LC23YN3	209-0133-203	Non-Diff.	Yellow (Amber)
LC23BN3	209-0134-203	Non-Diff.	Blue
LC23WT3	209-0135-203	Translucent	White
LC23CN3	209-0137-203	Non-Diff.	Colorless (Clear)
LC23RD3	209-0111-203	Diffusing	Red
LC23GD3	209-0112-203	Diffusing	Green
LC23YD3	209-0113-203	Diffusing	Yellow (Amber)
LC23BD3	209-0114-203	Diffusing	Blue
LC23CD3	209-0117-203	Diffusing	Colorless (Clear)
LC24RN3	210-0131-203	Non-Diff.	Red
LC24GN3	210-0132-203	Non-Diff.	Green
LC24YN3	210-0133-203	Non-Diff.	Yellow (Amber)
LC24BN3	210-0134-203	Non-Diff.	Blue
LC24CN3	210-0137-203	Non-Diff.	Colorless (Clear)
LC24RD3	210-0111-203	Diffusing	Red
LC24GD3	210-0112-203	Diffusing	Green
LC24YD3	210-0113-203	Diffusing	Yellow (Amber)
LC24BD3	210-0114-203	Diffusing	Blue
LC24WT3	210-0135-203	Translucent	White
LC24CD3	210-0117-203	Diffusing	Colorless (Clear)

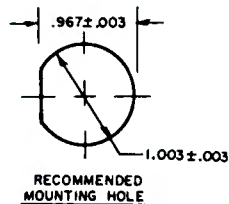

Lamp accommodation: S-6 bulb, double-contact, candelabra, bayonet base, incandescent (6V, 12V, 24V, 32V, 48V, 75V, 125V).

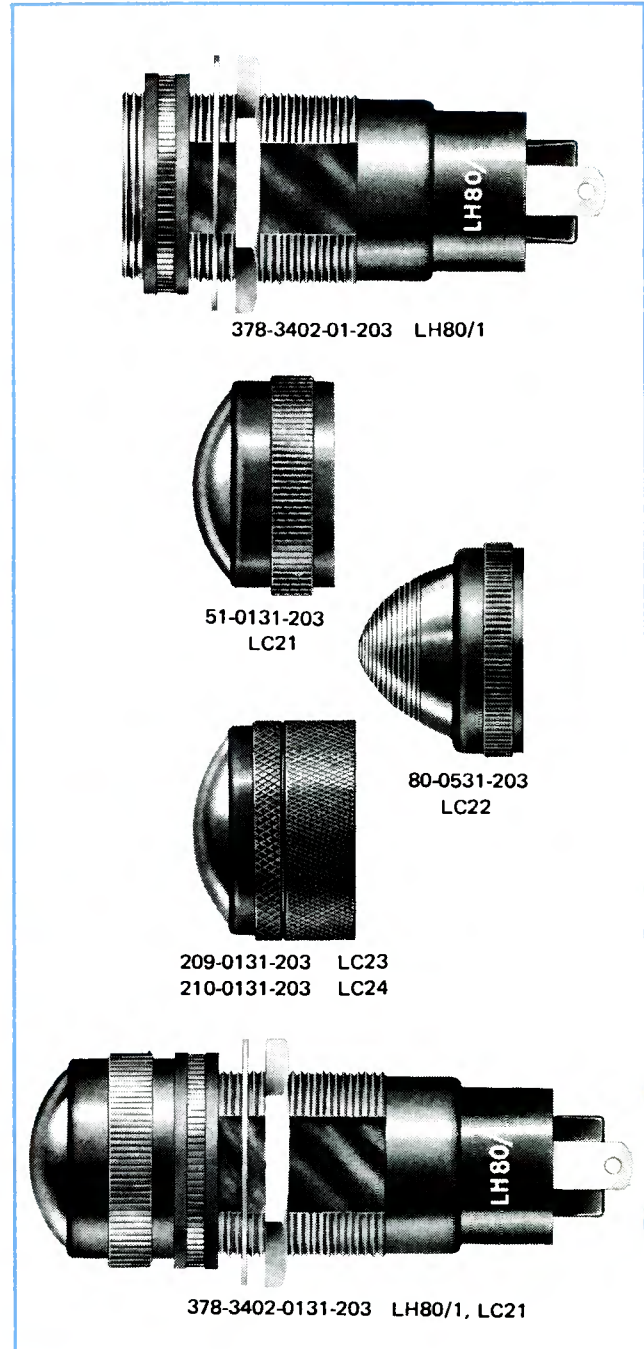



LHC81/11
520-1292-03-001

LEGEND

Typical Legend Plate
(See below)



LHC81/1
520-1291-03-001

With Typical
Legend Plate



INDICATOR LIGHT HOUSING	
TYPE DESIGNATION	DIALIGHT CATALOG NO.*
LHC81/1	520-1291-03-001
LHC81/2	520-1291-03-002
LHC81/3	520-1291-03-003
LHC81/4	520-1291-03-004
LHC81/5	520-1291-03-005
LHC81/6	520-1291-03-006
LHC81/7	520-1291-03-007
LHC81/8	520-1291-03-008
LHC81/9	520-1291-03-009
LHC81/10	520-1291-03-010
LHC81/11	520-1292-03-001
LHC81/12	520-1292-03-002
LHC81/13	520-1292-03-003
LHC81/14	520-1292-03-004
LHC81/15	520-1292-03-005
LHC81/16	520-1292-03-006
LHC81/17	520-1292-03-007
LHC81/18	520-1292-03-008
LHC81/19	520-1292-03-009
LHC81/20	520-1292-03-010

*See applicable lens description below.

Lamp accommodation: Two T-1 3/4 bulbs, midget flanged base, incandescent.

legend plate for LHC81/1-20

FUEL LOW

Typical Legend Plate

DIALIGHT CATALOG NO.	LEGEND PLATE COLOR
520-0371-100	Red
520-0372-100	Green
520-0373-100	Yellow (Amber)
520-0374-100	Blue
520-0375-100	White

DIALIGHT CATALOG NO.	UNDERLYING FILTER COLOR
520-0331-600	Red
520-0332-600	Green
520-0333-600	Yellow (Amber)
520-0334-600	Blue

COMPLETE ASSEMBLY		LENS DESCRIPTION	
TYPE DESIGNATION	DIALIGHT CATALOG NO.	FINISH	COLOR
LHC82/1RT2*	252-9951-0971	Translucent	Red
LHC82/1GT2*	252-9951-0972	Translucent	Green
LHC82/1YT2*	252-9951-0973	Translucent	Yellow (Amber)
LHC82/1BT2*	252-9951-0974	Translucent	Blue
LHC82/1WT2*	252-9951-0975	Translucent	White
LHC82/1CN2*	252-9951-0937	Transparent	Clear (Colorless)
LHC82/2RT2**	236-9951-0971	Translucent	Red
LHC82/2GT2**	236-9951-0972	Translucent	Green
LHC82/2YT2**	236-9951-0973	Translucent	Yellow (Amber)
LHC82/2BT2**	236-9951-0974	Translucent	Blue
LHC82/2WT2**	236-9951-0975	Translucent	White
LHC82/2CN2**	236-9951-0937	Transparent	Clear (Colorless)



252-9951-0971
LHC82/1RT2

236-9951-0971
LHC82/2RT2

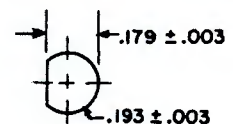

* Not electromagnetic interference shielded.
** Electromagnetic interference shielded.
Case must be grounded.

RECOMMENDED
MOUNTING HOLE



cross reference to military and ms numbers MIL-L-3661B

Rev F dated 26 May 1969 inactivated MS25256
 Rev G dated 4 June 1970 inactivated MS25257
 Rev C dated 20 July 1970 inactivated MS25446
 Rev E dated 5 February 1971 inactivated MS25010



359-8430-0931-502
 LH73/1, LC12RN2
 162-8430-0931-502
 MS25256-6

These drawings, with the exception of Type A and B Mounting Base to MS25010, have been superseded by the Military Type Designations and Dialight Catalog Numbers listed in the tables below. To facilitate future procurement for replacement purposes and due to the popularity of the MS assemblies we have continued to list them for your convenience.

MILITARY * STANDARD DWG. NO.	DIALIGHT CATALOG NO. TO MS DWG.	NEW ** DIALIGHT + CATALOG NO. TO MIL-L-3661 DWG.	CONSISTING OF		LENS DESCRIPTION	
			LAMPHOLDER	LENS	FINISH	COLOR
MS25256-2	162-8430-0933-502	359-8430-0933-502	LH73/1	LC12YN2	Non-diff.	Aviation Yellow
MS25256-4	162-8430-0932-502	359-8430-0932-502	LH73/1	LC12GN2	Non-diff.	Identification Green
MS25256-6	162-8430-0931-502	359-8430-0931-502	LH73/1	LC12RN2	Non-diff.	Identification Red
MS25256-8	162-8430-0937-502	359-8430-0937-502	LH73/1	LC12CN2	Non-diff.	Colorless
MS25256-10	162-8430-0975-502	359-8430-0975-502	LH73/1	LC12WT2	Translucent	Aviation White
MS25256-12	162-8430-0934-502	359-8430-0934-502	LH73/1	LC12BN2	Non-diff.	Aviation Blue



361-8836-0931-552
 LH74/1, LC13RN2
 137-8836-0931-552
 MS25257-4

MILITARY * STANDARD DWG. NO.	DIALIGHT CATALOG NO. TO MS DWG.	NEW ** DIALIGHT + CATALOG NO. TO MIL-L-3661 DWG.	CONSISTING OF		LENS DESCRIPTION	
			LAMPHOLDER	LENS	FINISH	COLOR
MS25257-2	137-8836-0933-552	361-8836-0933-552	LH74/1	LC13YN2	Non-diff.	Aviation Yellow
MS25257-4	137-8836-0931-552	361-8836-0931-552	LH74/1	LC13RN2	Non-diff.	Identification Red
MS25257-6	137-8836-0937-552	361-8836-0937-552	LH74/1	LC13CN2	Non-diff.	Colorless

- * Under the old MS number the complete assembly had to be ordered and the MS part number marked on the base is the one applicable to the complete assembly less lamp.
The new MIL-L-3661 number permits the ordering of the complete assemblies or separate lampholder and lens cap.
- ** The Military Type designation marked on the assembly is the part number for the lampholder only (less lens cap).
- + Lamps must be ordered separately.



252-9951-0971
 LHC82/1RT2
 MS25446-4

MILITARY STANDARD DWG. NO.	DIALIGHT + CATALOG NO. TO MS DWG.	MILITARY TYPE DESIGNATIONS	FINISH	COLOR
MS25446-2	252-9951-0974	LHC82/1BT2	Transl.	Aviation Blue
MS25446-3	252-9951-0972	LHC82/1GT2	Transl.	Identification Green
MS25446-4	252-9951-0971	LHC82/1RT2	Transl.	Identification Red
MS25446-5	252-9951-0975	LHC82/1WT2	Transl.	Aviation White
MS25446-6	252-9951-0973	LHC82/1YT2	Transl.	Aviation Yellow
MS25446-7	252-9951-0937	LHC82/1CN2	Transp.	Colorless

+ The Dialight part numbers for MS and MIL-L-3661B are identical.



271-8430-0111-702
 LH92/1, LC34EN2/EN2
 MS25010C11B

MILITARY ▲ STANDARD DWG. NO.	DIALIGHT + CATALOG NO. TO MS DWG.	CONSISTING OF		FILTER COLOR	TOP COLOR	MS. PART NO. FOR MTG. BASE	TERMINALS
		LAMPHOLDER	LENS				
MS25010C11B	271-8430-0111-702	LH92/1	LC34EN2/DO2	Red	Black	MS25010C	Two Solder
MS25010C12B	271-8430-0171-702	LH92/1	LC34CN2/DO2	Clear	Black	MS25010C	Two Solder
MS25010C13B	271-8430-3111-702	LH92/1	LC34EN2/EN2	Red	Red	MS25010C	Two Solder
MS25010C14B	271-8430-3171-702	LH92/1	LC34CN2/EN2	Clear	Red	MS25010C	Two Solder
MS25010C15B	271-8430-0212-702	LH92/1	LC34EN2/SO2	Red	Gray	MS25010C	Two Solder
MS25010C16B	271-8430-0272-702	LH92/1	LC34CN2/SO2	Clear	Gray	MS25010C	Two Solder

- + The Dialight part numbers for MS and MIL-L-3661B are identical.
- ▲ The MS and military type designation marked on the assembly is the part number for the lampholder only (less lens cap).



MIL-L-7806 LIGHT, PANEL, PLASTIC PLATE LIGHTING

See notes regarding Rev. E of MS25010 on preceding page

MILITARY STANDARD DWG. NO.**	DIALIGHT CATALOG NO.	FILTER COLOR	TOP COLOR	MS PART NO. FOR MTG. BASE	TERMINALS
MS25010A11A	270-1930-0111-702	Red	Black	MS25010A	One Solder
MS25010B11A	270-1830-0111-702	Red	Black	MS25010B	One Screw
MS25010A12A	270-1930-0171-702	Clear	Black	MS25010A	One Solder
MS25010B12A	270-1830-0171-702	Clear	Black	MS25010B	One Screw
MS25010A13A	270-1930-3111-702	Red	Red	MS25010A	One Solder
MS25010B13A	270-1830-3111-702	Red	Red	MS25010B	One Screw
MS25010A14A	270-1930-3171-702	Clear	Red	MS25010A	One Solder
MS25010B14A	270-1830-3171-702	Clear	Red	MS25010B	One Screw
MS25010A15A	270-1930-0212-702	Red	Gray	MS25010A	One Solder
MS25010B15A	270-1830-0212-702	Red	Gray	MS25010B	One Screw
MS25010A16A	270-1930-0272-702	Clear	Gray	MS25010A	One Solder
MS25010B16A	270-1830-0272-702	Clear	Gray	MS25010B	One Screw
MS25010C11B	271-8430-0111-702	Red	Black	MS25010C	Two Solder
MS25010C12B	271-8430-0171-702	Clear	Black	MS25010C	Two Solder
MS25010C13B	271-8430-3111-702	Red	Red	MS25010C	Two Solder
MS25010C14B	271-8430-3171-702	Clear	Red	MS25010C	Two Solder
MS25010C15B	271-8430-0212-702	Red	Gray	MS25010C	Two Solder
MS25010C16B	271-8430-0272-702	Clear	Gray	MS25010C	Two Solder

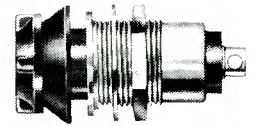

270-1930-0111-702
MS25010A11A

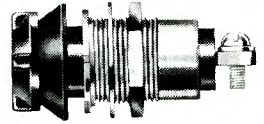

270-1830-0111-702
MS25010B11A



271-8430-0111-702
MS25010C11B

- The complete assembly will be marked with MS part number for mounting base only.
- To specify assembly with lamp No.327 or No.328, add lamp designation to suffix. Examples: MS25010B11A327; MS25010A13A328.

MIL-L-7961B LIGHT, INDICATOR, PRESS-TO-TEST

MILITARY STD. DWG. NO.	DIALIGHT CATALOG NO.	LENS DESCRIPTION	
		FINISH	COLOR
*MS25331-1	804-1710-0337-504	Unfrosted	Clear
*MS25331-2	804-1710-0331-504	Unfrosted	Red
*MS25331-3	804-1710-0332-504	Unfrosted	Green
*MS25331-4	804-1710-0333-504	Unfrosted	Amber
**MS25331-5	803-1710-0337-504	Unfrosted	Clear
**MS25331-6	803-1710-0331-504	Unfrosted	Red
**MS25331-7	803-1710-0332-504	Unfrosted	Green
**MS25331-8	803-1710-0333-504	Unfrosted	Amber
*To be assigned	804-1710-0334-504	Unfrosted	Blue
**To be assigned	803-1710-0334-504	Unfrosted	Blue
*MS25041-1	801-1030-0337-504	Unfrosted	Clear
*MS25041-2	801-1030-0331-504	Unfrosted	Red
*MS25041-3	801-1030-0332-504	Unfrosted	Green
*MS25041-4	801-1030-0333-504	Unfrosted	Amber
**MS25041-5	800-1030-0337-504	Unfrosted	Clear
**MS25041-6	800-1030-0331-504	Unfrosted	Red
**MS25041-7	800-1030-0332-504	Unfrosted	Green
**MS25041-8	800-1030-0333-504	Unfrosted	Amber
*MS25041-10	801-1030-0334-504	Unfrosted	Blue
**MS25041-11	800-1030-0334-504	Unfrosted	Blue

* Dimming

** Non-dimming

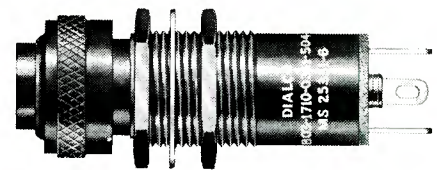

803-1710-0331-504 MS25331-6

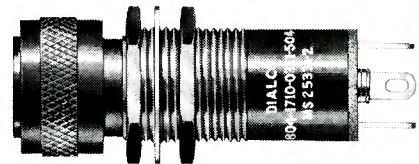

804-1710-0331-504 MS25331-2

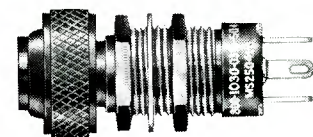

800-1030-0331-504 MS25041-6

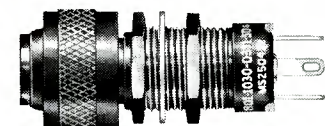

801-1030-0331-504 MS25041-2

additional products available from Dialight

(though not described in this catalog).

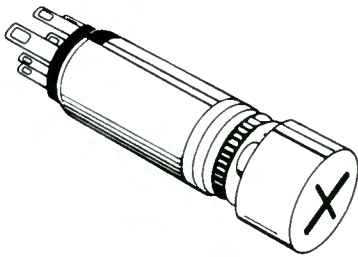

Incandescent lighted switches...panel mounting



Incandescent, LED or neon lighted switches

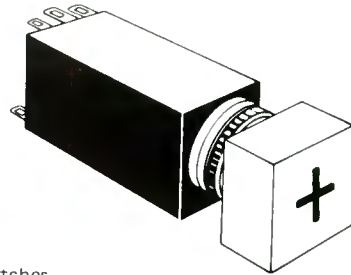

Contactless solid state switches

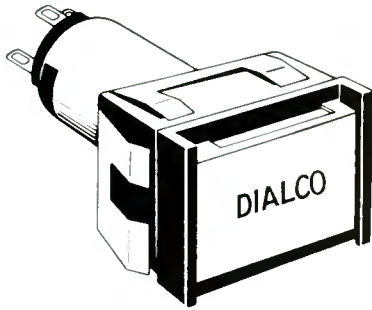

Incandescent lighted switches...snap-in mounting

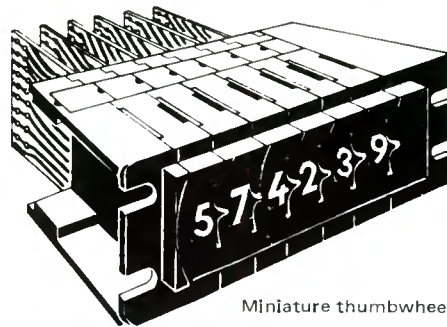

Miniature thumbwheel switches

LED DEVICES—available are LED lamps, logic/state fault indicators, ultra-miniature plug-in cartridges and indicator lights... all offering solid state long life reliability.

To obtain data on above items, ask for LED PRODUCT SELECTOR GUIDE - Catalog SG731.

READOUTS—LED . Gas Discharge . Incandescent—Single digit modules are available in .270", .300" or .625" and 1.000" heights. Displays and bezel mounted readout assemblies can also be obtained for quick, easy panel mounting.

To obtain data, ask for READOUT PRODUCT SELECTOR GUIDE - Catalog SG742.

SWITCHES—LED . Incandescent . Neon—Switches are available for most applications. Dialight can give you illuminated push button switches with unlimited cap and bezel options...solid state switches that eliminate all mechanical switching problems... LED lighted switches... even thumbwheel switches.

To obtain data, ask for Switch Catalogs L-210 and SW6120.

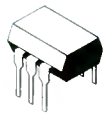

Opto-Isolators



Gas Discharge Readouts

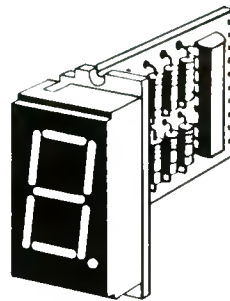

Readouts with PC board and D/D

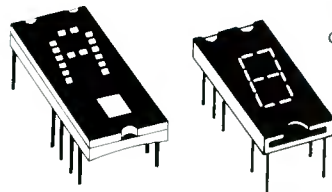
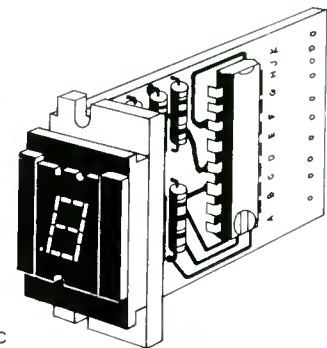

Readout modules

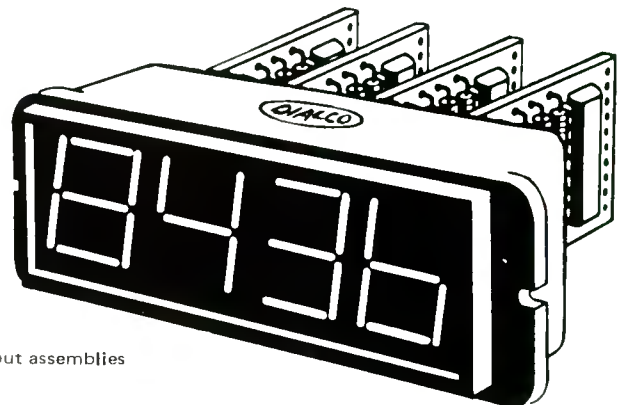
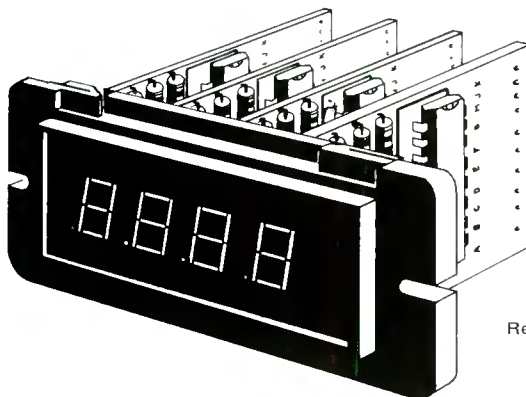

Readout assemblies

CURRENT LITERATURE

	catalog number	check here
INDICATOR LIGHTS		
Sub-Sub-Miniature.....	L-168.....	<input type="checkbox"/>
Ultra-Miniature.....	UM-1200.....	<input type="checkbox"/>
Sub-Miniature		
● One Terminal.....	L-157.....	<input type="checkbox"/>
● Edge lighting for Plastic Plates.....	L-158.....	<input type="checkbox"/>
● Two Terminals.....	L-178.....	<input type="checkbox"/>
Miniature, Large & Misc.		
● Digest of Indicator Lights.....	L-161.....	<input type="checkbox"/>
● Flashing Indicators.....	L-211.....	<input type="checkbox"/>
Oil-Tight.....	L-200.....	<input type="checkbox"/>
Press-to-Test.....	L-201.....	<input type="checkbox"/>
Placard Lights.....	L-170.....	<input type="checkbox"/>

Also available though not listed in this catalog

Switch Product Selector Guide.....	L-210.....	<input type="checkbox"/>
Readout Product Selector Guide.....	SG742.....	<input type="checkbox"/>
LED Product Selector Guide.....	SG731.....	<input type="checkbox"/>
Indicator Light Product Selector Guide.....	SG730.....	<input type="checkbox"/>

Send for your copies of these Catalogs.



DIALIGHT

203 HARRISON PLACE • BROOKLYN, N.Y. 11237 • 212 497-7600 • TWX: 710-584-5487

A NORTH AMERICAN PHILIPS COMPANY

DIALCO®

DETERMINATOR
INDICATOR LIGHTS



DIALIGHT



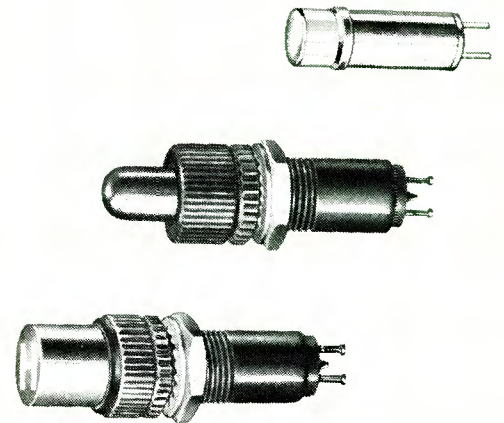

Datalite[®] Indicator Lights ***Incandescent · Neon · LED***



A NORTH AMERICAN PHILIPS COMPANY

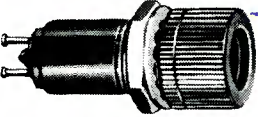
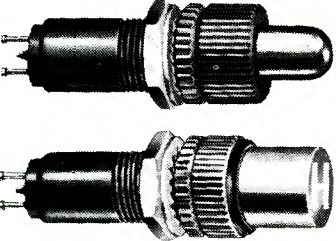

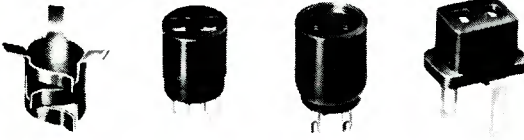
Catalog Index

	Description	See Page(s)
	Plug-in Datalamp Cartridges	4-8
	Datalamp Holders	9,19
	Indicator Lights for use with plug-in Datalamp Cartridges	10-11
	Military Indicators: Plug-in Cartridges covered by MS18235 thru MS18238. Datalites covered by MIL-L-3661B	12-14
	Permanent Lamp Indicator Lights with non-replaceable neon and LED light sources.	15-18
	Speed Clip and Cartridge Connectors	9
	Mounting Wrench	10
	Legend Standards	19

General Information

Characteristics & Performance

(Illustrations are approx. actual size. Dimensions are average values.)



INCANDESCENT DATALAMPS

Filament bulbs are used for circuit voltages ranging from 2.7 to 120 volts. Certain general characteristics are the same for all tungsten filament lamps. Understanding of their peculiarities will be valuable in their satisfactory usage.

Most notable is the effect of over and under voltage on incandescent lamps. Only 5% over voltage reduces life expectancy by 50% while 5% under voltage will double the life.

Undervoltage operation reduces watts and efficiency and therefore the amount of light. When 90% of rated volts is applied, the candlepower is 70% of rating and the current is 95% of nominal value.

Intermittent (or flashing) operation has no substantial adverse effect on the life of these tungsten filament lamps. A cold filament shows transient peak current about 10 times normal, but there is no overshooting of filament temperature. Sensitive switching devices are likely

to be affected. They may be protected by providing continuous "keep alive" current to the lamp at a level just below that which will make it faintly luminous.

Ratings of lamps in amperes are purely nominal and the values shown are subject to $\pm 7\%$ to $\pm 10\%$ tolerances. Quality control in lamp manufacture aims at producing lamps that will deliver rated hours at rated volts. Operation of lamps at nominal amperes will produce unsatisfactory life performance. It is undesirable to operate lamps from circuit voltages much higher than ratings by means of dropping resistors.

The maximum power that may be put into the small bulbs used in Datalites is 2 to 3 watts. High voltage lamps must have proportionately low current ratings, which means that the filaments are thinner and less rugged. It is obvious that when a choice may be made between the short thick filaments of low voltage lamps and the long thin filaments of higher voltage types, that the low voltage lamp is to be preferred.

Fortunately, neon lamps offer both high voltage operation and great ruggedness.



NEON DATALAMPS

Electrically, neon lamps are unique. They require a minimum firing voltage, and once started, current must be limited by a series resistor whose

value determines performance. Both the standard and the high brightness neons are each offered with 2 resistor values. In each case the lower value gives the best indication, with a minimum life of 5000 hours, while the higher value results in long life, preferred where 25000 hours or more operation may be required.

The blue and green light producing neons are of the high brightness type, and are supplied with one specific resistor value, for a life of 10000 hours.

No indicator light in this voltage range is more rugged or shows slower deterioration as it operates than the high brightness types of the neon T-2 series. Offering relatively constant light output through life, and five times the brightness of the standard T-2 neon, they should be used in all cases where the circuit voltage is adequate.

Neon Lamps for Circuit Component Uses

Lamps of the "standard brightness" type may be required with narrower limits on starting voltage than are characteristic of run of factory product. Seasoned and selected lamps will be provided in Datalamps on request. Practical limits are 72 ± 8 volts and, at higher cost, 72 ± 4 volts. All selected lamps contain radio-active additive for more stable starting voltage characteristics. The shielding provided by the Datalamp housing, if grounded, adds a useful stabilizing effect.



SOLID STATE DATALAMPS

Diode-Lites (Dialight's registered trademark for its LED) are the light source for a series of cartridges and indicator lights used for circuit voltages of 3.6 to 28V DC.

5800 Å for the yellow portions of the spectrum.

All of this emitted light is of the same general wave length, known as monochromatic. As a result, you cannot put different filters over it and get different colored light.

Power requirements are low and the device can be driven directly by RTL, DTL and TTL logic. Response time is measured in nano seconds, and being a solid state device, the Diode-Lite is just about impervious to mechanical vibration and other environmental conditions, while having a life expectancy measured in years.

Basic materials are Gallium Arsenide Phosphide and Gallium Phosphide, forming PN junction diodes which, when biased in the forward direction, give off energy in the form of light (photons). This light typically peaks at 6700 Å for the red, 5600 Å for the green, and

HOW TO DESIGNATE THE THREE DIGIT CATALOG NUMBER SUFFIX (—XXX)

Finish	Resistor	Hardware
-5 black anodize	0 - None	0 - None
-6 clear anodize	1 - 22K	4 - Aluminum
	3 - 33K	
	4 - 56K	
	7 - 100K	

Note: The part numbers given in this catalog indicate standard indicator lights. The table at left provides the standard and optional designations for Finish, Resistor (for Neon assemblies only) and Hardware, where appropriate.

Examples: 507-4538-0937-530 (black anodize, 33K resistor, no hardware); 508-8738-604 (clear anodize, no resistor, aluminum hardware).

Incandescent plug-in

2.7 to 120V

MATERIALS AND FINISHES

Housing: Aluminum. Standard finish - clear anodize.
Optional - black anodize. Other finishes available on special order.

Connections: Stainless steel pins mounted in nylon insulated header.
Offset to provide polarization.

Lens: Heat resistant, high strength plastic. Permanently attached to the open end of the housing.

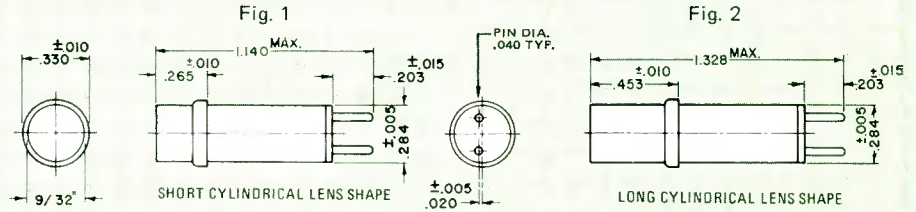

Design Voltage	mA	C.P.	Life Hours average	Δ Short Cylindrical	Δ Long Cylindrical
				Fig. 1	Fig. 2
2.7	60	.04	6,000	507-3903-1431-600	507-3903-1531-600
3.0	15	.005	20,000	507-3904-1431-600	507-3904-1531-600
5.0	60	.053	25,000	507-3951-1431-600	507-3951-1531-600
6.0	40	.03	10,000	507-3905-1431-600	507-3905-1531-600
6.0	200	.60	1,000	507-3906-1431-600	507-3906-1531-600
6.0	140	0.7 ++	5,000		
6.3	40	.03	20,000	507-3907-1431-600	507-3907-1531-600
6.3	200	.40	20,000	507-3909-1431-600	507-3909-1531-600
6.3	200	.55	5,000	507-3943-1431-600	507-3943-1531-600
10.0	14	.004	50,000	507-3910-1431-600	507-3910-1531-600
10.0	40	.08	10,000	507-3911-1431-600	507-3911-1531-600
12.0	170	2.1 ++	5,000		
12.0	40	.10	10,000	507-3944-1431-600	507-3944-1531-600
14.0	80	.30	15,000	507-3914-1431-600	507-3914-1531-600
14.0	80	.50	1,500	507-3913-1431-600	507-3913-1531-600
14.0	17	.03	25,000	507-3912-1431-600	507-3912-1531-600
18.0	40	.15	1,000	507-3916-1431-600	507-3916-1531-600
18.0	20	.08	15,000	507-3915-1431-600	507-3915-1531-600
28.0	40	.30	7,000	507-3918-1431-600	507-3918-1531-600
28.0	40	.34	4,000	507-3917-1431-600	507-3917-1531-600
28.0	40	1.2 ++	5,000		
48.0	53	1.5 ++	5,000		
60.0	50	2.2 ++	5,000		
120.0	25	1.5 ++	5,000		

* Recommended and available only in transparent lens color due to low current.

+ Clear colorless lens with matted back, only.

Δ All catalog numbers in the above chart designate cartridges with transparent lens. To specify cartridges with translucent lens, change the "3" in -1431- or -0331- to "7". Examples: 507-3906-1471-600; 507-3918-0372-600.

++ Relative luminosity end-on.

Notes

1 - Use cartridge with clear (colorless) lens with complete indicators (Illus. A and B - pages 10-11).

2 - Use cartridge with either transparent or translucent lens finish with Datalamp Holder (Illus. C - page 9), or complete indicator (Illus. D - page 10).

■ Ratings of lamps are taken from published catalogs of leading lamp manufacturers.

Rated life is generally recognized as the 50% failure point of a group of lamps tested under static laboratory conditions, with the voltage closely regulated at the design value. This may not necessarily agree with the service life of a lamp where the effects of temperature, shock, vibration and voltage fluctuations may result in a shorter than rated life.

LENS COLOR CODE

Number	Lens Color
1	Red
2	Green
3	Yellow (Amber)
4	Blue
5	White Translucent
6	Lt. Yellow
7	Clear Colorless

Example: 507-3906-1433-600 (Yellow Amber).

Datalamp Cartridges

2.7 to 120V



LEGENDS

See "Ordering Custom Legend Markings" on page 19.

MARKINGS

Markings on Datalamp cartridges include DIALCO, basic DATALAMP series number, voltage and milliamps: (e.g. DIALCO 507-3909-6.3V 200MA).

Fig. 3

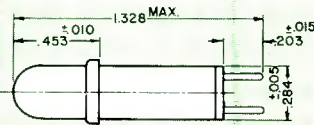

STOVEPIPE LENS SHAPE

Fig. 4

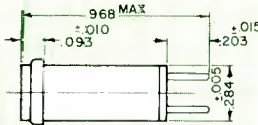

FLAT LENS SHAPE

Fig. 5



PLANO CONVEX LENS SHAPE

				Accommodated By:	
Δ Stovepipe	Δ Flat	Plano Convex	Lens Colors	Datalamp Holder	Complete Indicator(s)
Fig. 3	Fig. 4	Fig. 5		See Page 9	See Pages 10-11
507-3903-0931-600	507-3903-0331-600		All	C	A, D
507-3904-0931-600	507-3904-0331-600		* All	C	A, D
507-3951-0931-600	507-3951-0331-600		All	C	A, D
507-3905-0931-600	507-3905-0331-600		All	C	A, D
507-3906-0931-600	507-3906-0331-600		All	C	A, D
		507-5819-0747-600	+	-	B
507-3907-0931-600	507-3907-0331-600		* All	C	A, D
507-3909-0931-600	507-3909-0331-600		All	C	A, D
507-3943-0931-600	507-3943-0331-600		All	C	A, D
507-3910-0931-600	507-3910-0331-600		* All	C	A, D
507-3911-0931-600	507-3911-0331-600		All	C	A, D
		507-5820-0747-600	+	-	B
507-3944-0931-600	507-3944-0331-600		All	C	A, D
507-3914-0931-600	507-3914-0331-600		All	C	A, D
507-3913-0931-600	507-3913-0331-600		All	C	A, D
507-3912-0931-600	507-3912-0331-600		* All	C	A, D
507-3916-0931-600	507-3916-0331-600		All	C	A, D
507-3915-0931-600	507-3915-0331-600		All	C	A, D
507-3918-0931-600	507-3918-0331-600		All	C	A, D
507-3917-0931-600	507-3917-0331-600		All	C	A, D
		507-5821-0747-600	+	-	B
		507-5822-0747-600	+	-	B
		507-5823-0747-600	+	-	B
		507-5824-0747-600	+	-	B

**SOLID STATE (LED)
DATALAMP CARTRIDGES**

SEE PAGE 8

Features **low power** requirements and **long life** reliability.

**MILITARY SPECIFICATIONS
MIL-L-3661B**

SEE PAGES 12-13

**CARTRIDGE CONNECTORS
AND SPEED CLIP**

SEE PAGE 9



Neon plug-in

High Brightness: 110-125V AC

MATERIALS AND FINISHES

- **Housing:** Aluminum. Standard finish - clear anodize. Optional - black anodize. Other finishes available on special order.
- **Connections:** Stainless steel pins mounted in nylon insulated header. Offset to provide polarization.
- **Lens:** Heat resistant, high strength plastic. Permanently attached to the open end of the housing.

MARKINGS

Markings on Datalamp cartridge include DIALCO, basic Datalamp series number and resistor value.
Example: DIALCO 507-4538 33K

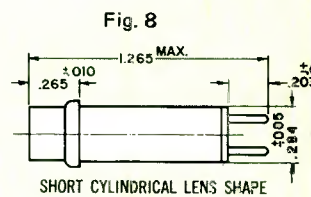
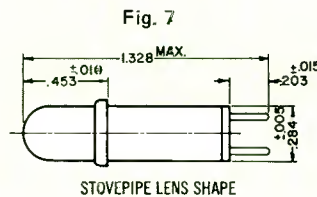
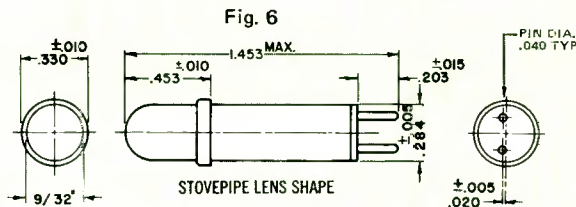

	Design Voltage	Lamp	Hours*	Built-in Resistor	Stovepipe	Stovepipe	Short Cylindrical
					Fig. 6	Fig. 7	Fig. 8
High Brightness	110-125V AC	A1C	5,000	22K	507-4538-0931-610		507-4538-1431-610
	110-125V AC	A1C	25,000	33K	507-4538-0931-630		507-4538-1431-630
	110-125V AC	NE2H	5,000	□ NONE		507-3836-0931-600	
	110-125V AC	A1C	25,000	□ NONE			
	110-125V AC	A1C	5,000	22K		507-5338-0931-610	
	110-125V AC	A1C	25,000	33K		507-5338-0931-630	
	110-125V AC	G2B	10,000	33K	△ 507-4576-0932-630		
	110-125V AC	T2B	10,000	33K	■ 507-4577-0934-630		
Standard Brightness	105-125V AC-DC	A1B	3,000	56K	507-4537-0931-640		507-4537-1431-640
	105-125V AC-DC	A1B	15,000	100K	507-4537-0931-670		507-4537-1431-670
	105-125V AC-DC	NE2E	3,000	□ NONE		507-3835-0931-600	
	105-125V AC-DC	A1B	15,000	□ NONE			
	105-125V AC-DC	A1B	3,000	56K		507-5337-0931-640	
	105-125V AC-DC	A1B	15,000	100K		507-5337-0931-670	

Note: The above catalog numbers (with the exception of blue and green cartridges which are so noted) designate cartridges with red lens. Refer to Lens Color Code on facing page for other colors.

Important: If Datalamp cartridge is to be used with complete indicator (illus. E & F, pages 10-11), specify clear colorless lens only.

To obtain optional black anodize finish, change the "6" in the catalog number suffix to "5".

Example: 507-4538-0931-510

□ The necessary current-limiting resistor must be added externally. See the chart with recommended resistance values on the facing page.

+ These Datalamp Cartridges are listed to extend the range of the 507-5824-0747-600 incandescent cartridges (described on pages 4-5) to 125 volts. The cartridge is accommodated by complete indicator B only (see pages 10-11).

△ Green neon lamps must be used with green lens only.

■ Blue neon lamps must be used with blue lens only.

6 ♦ Replacement is indicated when darkening of the lamp is observed.

NEW! BLUE OR GREEN
NEON DATALAMP CARTRIDGES

Datalamp cartridges are now offered with neon lamps producing green or blue light. In indicator light applications, neon lamps have been previously limited to the orange and red colors which are characteristics of neon gas. Now with the addition of green and blue the complete spectrum of colors can be provided for the 120 volt indicator needs. Applications can now use both lamp types to emphasize multiple functions by the use of colors.

See data and Part Numbers under FIGS. 6 & 10 in chart above.

Datalamp Cartridges

Standard Brightness: 105-125V AC-DC

RECOMMENDED BUILT-IN RESISTANCE VALUES

Neon Lamp	Volts Applied to Terminals	Bright Light	Long Life
		Resistor and Approx. Life	Resistor and Approx. Life
High Brightness			
A1C	110-125 AC only	22K 5,000 hrs.	33K 25,000 hrs.
G2B	110-125 AC only	—	33K 10,000 hrs.
T2B	110-125 AC only	—	33K 10,000 hrs.
Standard Brightness			
A1B	105-125 AC or DC	56K 3,000 hrs.	100K 15,000 hrs.

Change the second digit in the catalog number suffix to designate the appropriate built-in resistor as follows:
22K-1; 33K-3; 56K-4; 100K-7. Example: 507-4537-0931-670.

LENS COLOR CODE

Number	Color Code
1	Red
2	Green
3	Yellow (Amber)
4	Blue
5	White
6	Light Yellow
7	Clear Colorless

Example: 507-4537-0935-670 (White)
Blue and green colors, transparent only, are for use with blue and green lamps only.

Fig. 9

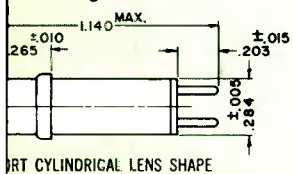

Fig. 10

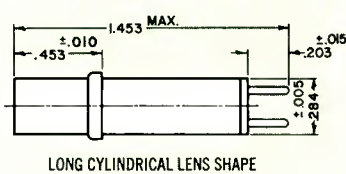

Fig. 11

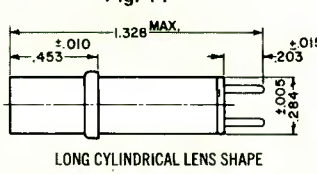
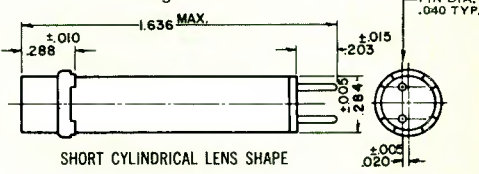

Fig. 13



Short Cylindrical Fig. 9	Long Cylindrical Fig. 10	Long Cylindrical Fig. 11	Short Cylindrical Fig. 13+	Accommodated By:		Lens Colors Available (See Above)
				Datalamp Holder See Page 9	Complete Indicator(s) See Pages 10-11	
	507-4538-1531-610		507-5838-1431-610	G	D, E	1, 3, 5, 6, 7
	507-4538-1531-630			G	D, E	1, 3, 5, 6, 7
		507-3836-1531-600		C	D, F	1, 3, 5, 6, 7
507-3838-1431-600				C	D, F	1, 3, 5, 6, 7
		507-5338-1531-610		C	D, F	1, 3, 5, 6, 7
		507-5338-1531-630	507-5838-1431-630	C	D, F	1, 3, 5, 6, 7
	507-4576-1532-630			G	D, E	2
	507-4577-1534-630			G	D, E	4
	507-4537-1531-640			G	D, E	1, 3, 5, 6, 7
	507-4537-1531-670			G	D, E	1, 3, 5, 6, 7
		507-3835-1531-600		C	D, F	1, 3, 5, 6, 7
507-3837-1431-600				C	D, F	1, 3, 5, 6, 7
		507-5337-1531-640		C	D, F	1, 3, 5, 6, 7
		507-5337-1531-670		C	D, F	1, 3, 5, 6, 7

LED DATALAMP® PLUG-IN CARTRIDGES with Pre-aged, Seasoned and Selected features.

Selected lamps can be provided when low circuit voltages are required for DC applications. These Neon Datalamps will be provided with 68 to 76 volt range of starting voltage and at lower cost with 64 to 80 volt range.

Other ranges can be provided. All selected lamps are treated to insure high insulation resistance and are seasoned before selection. All contain radioactive additive to reduce dark starting

effect on voltage. Please note that Datalamp Cartridges without built-in resistor are accommodated by Datalamp Holder C (see page 9) and complete indicator lights A and D (see pages 10-11); Datalamp Cartridges with built-in resistor are accommodated by Datalamp Holder G (see page 9) and complete indicators D and E (see pages 10-11).

Lens Color: See Lens Color Code above.

Datalamp Cartridges Without Built-in Resistor			*Datalamp Cartridges with Built-in Resistor	
Starting Volts	Stovepipe	Long Cylindrical	Stovepipe	Long Cylindrical
72 ± 4	507-3840-0931-600	507-3840-1531-600	507-4540-0931-640	507-4540-1531-640
72 ± 8	507-3839-0931-600	507-3839-1531-600	507-4539-0931-640	507-4539-1531-640

*The given catalog numbers indicate use of 56K built-in resistor. If other value is desired, change the appropriate digit in the catalog number to the designation noted in chart "Recommended Built-in Resistance Values" above.

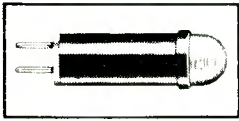

Datalamp Cartridges with solid-state **DIODE-LITES™**

(Illustrations are approx. actual size. Dimensions are average values.)

FEATURES

- Low power requirements
- Integrated circuit compatibility
- Solid state reliability - life measured in years
- Immune to shock and vibration
- Operating temperatures -55°C to +60° C.
- Interchangeable with Incandescent Datalamp Cartridges
- Transient free switching

A new addition has been made to Dialight's Datalite family of indicators...a Datalamp cartridge series accommodating a DIODE-LITE™ (LED). The light source is a solid state lamp that provides the advantages of **low power** with **extremely long life**, **reliability** measured in years, and is compatible with integrated circuits (can be driven directly by RTL, DTL and TTL logic).

OPERATING VOLTAGES: The Datalamp cartridges with solid state DIODE-LITES™ may be used as direct replacements for existing cartridges using an incandescent lamp operating from a DC power source. The former series is available in a range of voltages from 3.6 to 28V DC at a maximum current of 20 mA. Tolerances on the DC voltage should be within 5% of the specified voltage on the cartridge.



UNIQUE LENS DESIGN: Dialight uses an internal fresnel ring pattern in its lens design. This assures maximum distribution of the light output from the DIODE-LITE™. The lens area is completely flooded with light.

MAXIMUM CONTRAST: The Datalamp cartridge is supplied in a black anodized finish (standard) which produces a high contrast ratio. Such a ratio is desirable for optimum indication.

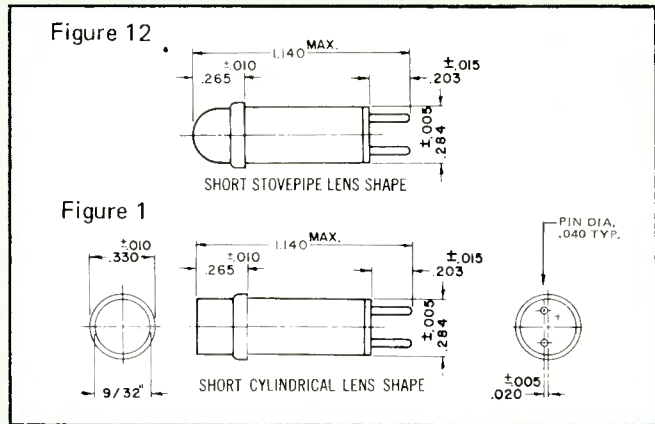

MATERIALS AND FINISHES

- **Housing:** Aluminum. Standard finish—black anodize. Optional—clear anodize.
- **Connections:** Stainless steel pins mounted in nylon insulated header. Offset to provide polarization.
- **Lens:** High strength plastic. Permanently attached to open end of the housing.

POLARITY: To facilitate proper installation of the cartridge, the polarity is marked (+) on the cartridge housing and the terminal base is keyed.

MOUNTING: This series Datalamp cartridge may be used with a Datalamp holder or cartridge connector with speed clip described on the facing page.

Ordering Information

20mA DATALAMP CARTRIDGES WITH SHORT CYLINDRICAL LENS - WITH FRESNEL RINGS ☆							
WITH LED	TRANSPARENT LENS COLOR	3.6V DC	5V DC	6V DC	10V DC	14V DC	28V DC
RED	Red	507-4756-3331-500	507-4757-3331-500	507-4758-3331-500	507-4759-3331-500	507-4760-3331-500	507-4761-3331-500
	White	507-4756-3335-500	507-4757-3335-500	507-4758-3335-500	507-4759-3335-500	507-4760-3335-500	507-4761-3335-500
	Clear	507-4756-3337-500	507-4757-3337-500	507-4758-3337-500	507-4759-3337-500	507-4760-3337-500	507-4761-3337-500
	10mA Units	507-4763-xxxx-500	507-4764-xxxx-500	507-4765-xxxx-500	507-4766-xxxx-500	507-4767-xxxx-500	507-4768-xxxx-500
GREEN	Green	507-4856-3332-500	507-4857-3332-500	507-4858-3332-500	507-4859-3332-500	507-4860-3332-500	507-4861-3332-500
	White	507-4856-3335-500	507-4857-3335-500	507-4858-3335-500	507-4859-3335-500	507-4860-3335-500	507-4861-3335-500
	Clear	507-4856-3337-500	507-4857-3337-500	507-4858-3337-500	507-4859-3337-500	507-4860-3337-500	507-4861-3337-500
YELLOW	Yellow (amber)	507-4956-3333-500	507-4957-3333-500	507-4958-3333-500	507-4959-3333-500	507-4960-3333-500	507-4961-3333-500
	White	507-4956-3335-500	507-4957-3335-500	507-4958-3335-500	507-4959-3335-500	507-4960-3335-500	507-4961-3335-500
	Clear	507-4956-3337-500	507-4957-3337-500	507-4958-3337-500	507-4959-3337-500	507-4960-3337-500	507-4961-3337-500

☆ To obtain cartridges with short stovepipe lens shape, change the first two digits in the 3rd code block from 33 to 37. Examples: 507-4856-3735-500; 507-4959-3737-500.

Note: The catalog numbers in this chart designate cartridges with standard black anodize finish.

To specify optional clear anodize finish, change the 5 in the catalog number to 6. Example: 507-4765-3337-600.

Datalamp Holder "C" (Page 9) accommodates these series Datalamp cartridges. The terminals of the holder are marked "A" and "B". The "A" terminal would denote positive (+) polarity. This feature insures proper installation and wiring.

Cartridge Connectors (Cat. No. 515-0012 and 515-0074) and Speed Clip (Cat. No. 515-0051) are described on page 9. The terminals of the connectors are marked "A" and "B". The "A" terminal would denote positive (+) polarity. This feature insures proper installation and wiring.

Datalamp Holders



The panel mounting Datalamp Holder is available with or without screw-on collar. If the conditions of use demand that the plug-in Datalamp Cartridge be very securely retained, the necessary thread is left exposed in mounting and the collar is used and screwed down tight.

Note: When Datalamp Holders are used with Neon Cartridges without built in resistor, the necessary current-limiting resistor must be added externally. See the chart recommended resistance values on Page 7.

MATERIALS AND FINISHES — Datalamp Holders

- **Mounting bushing, collar and flange nut:** Aluminum. Standard finish - black anodize. Optional - clear anodize.
- **Mounting Nut:** Brass, white nickel finish.
- **Internal-tooth Lockwasher:** Phosphor bronze, white nickel finish.
- **Terminals:** Phosphor bronze, gold plated.

DATALAMP HOLDER Only		Accommodate Cartridge Figure Numbers	Turret Terminals	Solder Cup Terminals	Amp "53" Taper Pin Receptacles	Solder Blade Terminals	Dim. "A" (max.)
C		1-4, 7, 9, 11, 12	508-8738-504	508-7538-504	508-9038-504	508-7438-504	57/64"
		1-4, 7, 9, 11, 12	250-8738-14-504	250-7538-14-504	250-9038-14-504	250-7438-14-504	1-1/32"
G		6, 8, 10	508-8745-504	508-7545-504	508-9045-504	508-7445-504	63/64"
		6, 8, 10	250-8745-14-504	250-7545-14-504	250-9045-14-504	250-7445-14-504	1-1/8"

Note: To obtain Datalamp with optional clear anodize finish, change "5" in -504 to "6". Example: 508-8738-604.

CARTRIDGE CONNECTORS and SPEED CLIP

For use in mounting Incandescent and Neon Datalamp Cartridges in 9/32" clearance hole.

Direct mounting of Datalamp Cartridges on the panel is possible using the accessories illustrated. The Datalamp is inserted through a clearance hole and is secured by sliding the speed clip over the housing from the rear. The connector is adapted for soldered wire leads and fits the Datalamp plug-in pins.

Speed clips and cartridge connectors are recommended for use with Neon or long life low powered Incandescent Datalamp cartridges. Where high powered Incandescent Datalamps are required, consideration of heat dissipation must be given.

Not providing a Datalamp holder (which acts as a heat sink) may cause shorter filament life for high powered Incandescent Datalamps unless used on an intermittent basis.

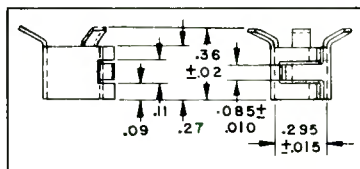

We suggest that installation be made on metal panels only.

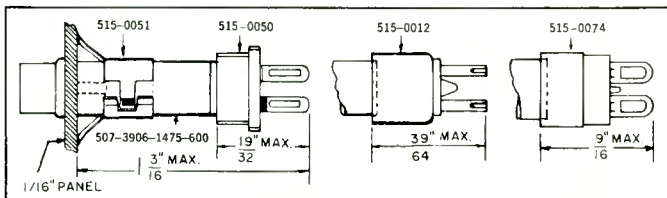

SPEED CLIP

CARTRIDGE CONNECTORS



515-0051



515-0074



515-0012



515-0050

Dimensions are average values.)

DATALITE PROJECTIONS FRONT AND BACK OF PANEL **

C Lamp-holder	Datalamp Holder				
	Datalamp Lens Shape	*With Collar		*W/O Collar	
		Front Proj.	Back Proj.	Front Proj.	Back Proj.
Flat	1/2"	57/64"	7/32"	1-1/32"	
Short Cylindrical	21/32"	57/64"	3/8"	1-1/32"	
Short Stovepipe	21/32"	57/64"	3/8"	1-1/32"	
Stovepipe (Standard)	7/8"	57/64"	39/64"	1-1/32"	
Long Cylindrical	7/8"	57/64"	39/64"	1-1/32"	

G Lamp-holder	Datalamp Holder				
	Datalamp Lens Shape	*With Collar		*W/O Collar	
		Front Proj.	Back Proj.	Front Proj.	Back Proj.
Short Cylindrical	21/32"	63/64"	3/8"	1 1/8"	
Stovepipe (standard)	7/8"	63/64"	39/64"	1 1/8"	
Long Cylindrical	7/8"	63/64"	39/64"	1 1/8"	

* Dimensions are average values. ** 1/16" panel thickness (ref.)

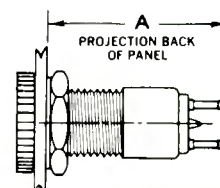
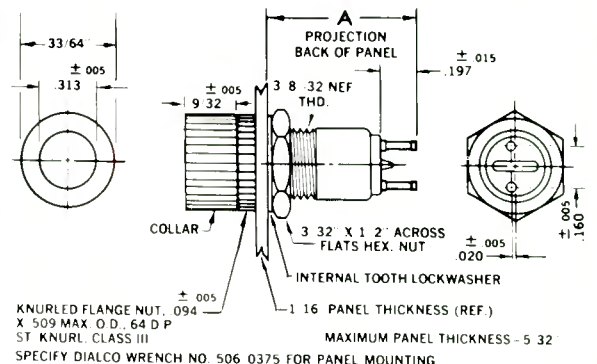

Datalite[®] specifications and

The Datalite Indicator consists of:

- 1- the main body, or **Datalamp Holder**, which is adapted for permanent mounting on the panel and
- 2- the screw-on **Data Cap**.







Data Caps are offered with three types of lens finishes:

- 1- **Transparent**. These caps are especially useful with low powered incandescent or Neon Datalamp cartridges.
- 2- **Translucent**. These caps are for use with Incandescent Datalamp cartridges. They provide a uniform lighted background for opaque legends.
- 3- **Transparent with internal fresnel** diffusing rings.

All lenses are rotatable for erect positioning of legends. A spring loaded friction device prevents accidental rotation.

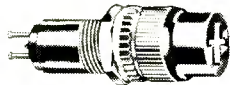

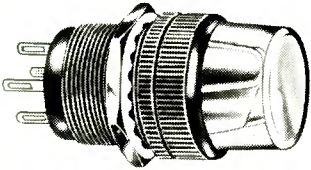
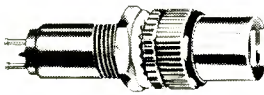
WRENCH 506-0375: The threaded round knurled nut used on the indicator lights described in this catalog has a precise knurl of this specification: 64 D.P. ST. Knurl, Class III. Wrench 506-0375 is offered to permit fastening of these indicators on mounting panels.

INDICATOR LIGHT	Light Source	Accommodate Cartridge Figure Numbers		 Turret Terminals	 Solder Cup Terminals
A' 	INCANDESCENT	1,4	Transparent	250-8738-1431-504	250-7538-1431-504
		1,4	Translucent	250-8738-1471-504	250-7538-1471-504
		1,4	Fresnel	250-8738-3331-504	250-7538-3331-504
		2,3	Transparent	250-8738-1531-504	250-7538-1531-504
		2,3	Fresnel	250-8738-1631-504	250-7538-1631-504
B' 	INCANDESCENT	5, 13	Translucent	250-8758-1471-504	250-7558-1471-504
		5,13	Fresnel	250-8758-3331-504	250-7558-3331-504
D+ 	INCANDESCENT & NEON	1-4, 7, 9, 11	Transparent	_____	_____
		6-8, 10	Transparent	_____	_____
E' 	NEON	8	Transparent	250-8745-1431-504	250-7545-1431-504
		8	Fresnel	250-8745-3331-504	250-7545-3331-504
		6, 10	Transparent	250-8745-1531-504	250-7545-1531-504
		6, 10	Fresnel	250-8745-1631-504	250-7545-1631-504
F' 	NEON	9	Transparent	250-8738-1431-504	250-7538-1431-504
		9	Fresnel	250-8738-3331-504	250-7538-3331-504
		7, 11	Transparent	250-8738-1531-504	250-7538-1531-504
		7, 11	Fresnel	250-8738-1631-504	250-7538-1631-504

Note: The above catalog numbers designate complete indicators with standard black anodize finish. To obtain optional clear anodize finish, change "5" in the catalog number suffix to "6". Example: 250-8745-1431-604.

¹ (Illust. approx. 70% actual size.)

² (Illust. approx. 80% actual size.)

BASE ASSEMBLY CATALOG NUMBERS

Indicator Light Illus:	Turret Terminals	Solder Blade Terminals	Solder Cup Terminals	Amp "53" Taper Pin Receptacles
A	250-8738-14-504	250-7438-14-504	250-7538-14-504	250-9038-14-504
B	250-8758-33-504	_____	250-7558-33-504	_____
D	_____	253-6939-14-504	_____	_____
	_____	253-6945-14-504	_____	_____
E	250-8745-14-504	250-7445-14-504	250-7545-14-504	250-9045-14-504
F	250-8738-14-504	250-7438-14-504	250-7538-14-504	250-9038-14-504

ordering information



MATERIALS AND FINISHES

Datalamp Holder

- Mounting bushing, collar and flange nut: Aluminum. Standard finish - black anodize. Optional - clear anodize.
- Mounting Nut: Brass, white nickel finish.
- Internal-tooth Lockwasher: Phosphor bronze, white nickel finish.
- Terminals: Phosphor bronze, gold plated.

Data Cap

- Lens: High heat resisting plastic. Spring mounted, rotatable.
- Lens Holder: Aluminum. Standard finish - black anodize. Optional - clear anodize.

Legend Specifications: See page 19.

For Datalites covered by MIL-L-3661B, see pages 12-14.

Note: Similar assemblies accommodating non-replaceable lamps - for mounting in 3/8" clearance holes - are described on pages 16-18.

Amp "53" Taper Pin Receptacles	Solder Blade Terminals	Dim. "A"	Data Cap Number*
250-9038-1431-504	250-7438-1431-504	29/32"	250-1431-500
250-9038-1471-504	250-7438-1471-504	29/32"	250-1471-500
250-9038-3331-504	250-7438-3331-504	29/32"	250-3331-500
250-9038-1531-504	250-7438-1531-504	29/32"	250-1531-500
250-9038-1631-504	250-7438-1631-504	29/32"	250-1631-500
_____	_____	1.428"	250-1471-500
_____	_____	1.428"	250-3331-500
_____	253-6939-1431-504	63/64"	253-1431-500
_____	253-6945-1431-504	1 1/16"	253-1431-500
250-9045-1431-504	250-7445-1431-504	63/64"	250-1431-500
250-9045-3331-504	250-7445-3331-504	63/64"	250-3331-500
250-9045-1531-504	250-7445-1531-504	63/64"	250-1531-500
250-9045-1631-504	250-7445-1631-504	63/64"	250-1631-500
250-9038-1431-504	250-7438-1431-504	29/32"	250-1431-500
250-9038-3331-504	250-7438-3331-504	29/32"	250-3331-500
250-9038-1531-504	250-7438-1531-504	29/32"	250-1531-500
250-9038-1631-504	250-7438-1631-504	29/32"	250-1631-500

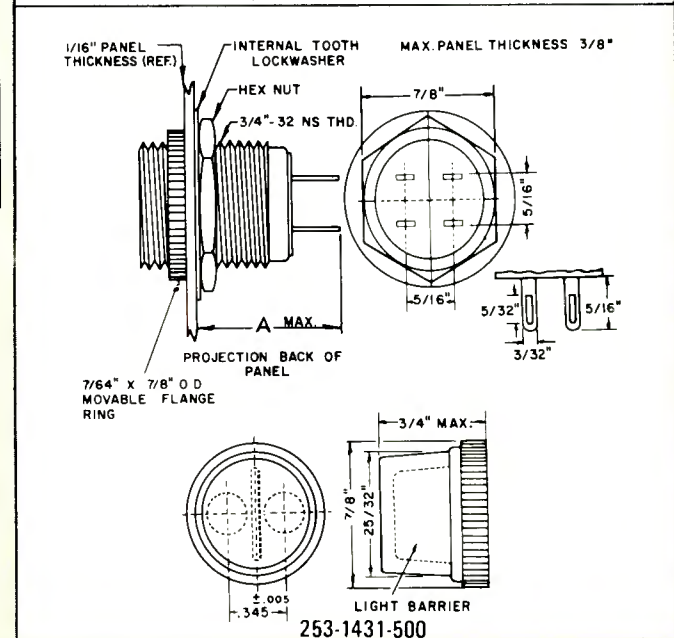
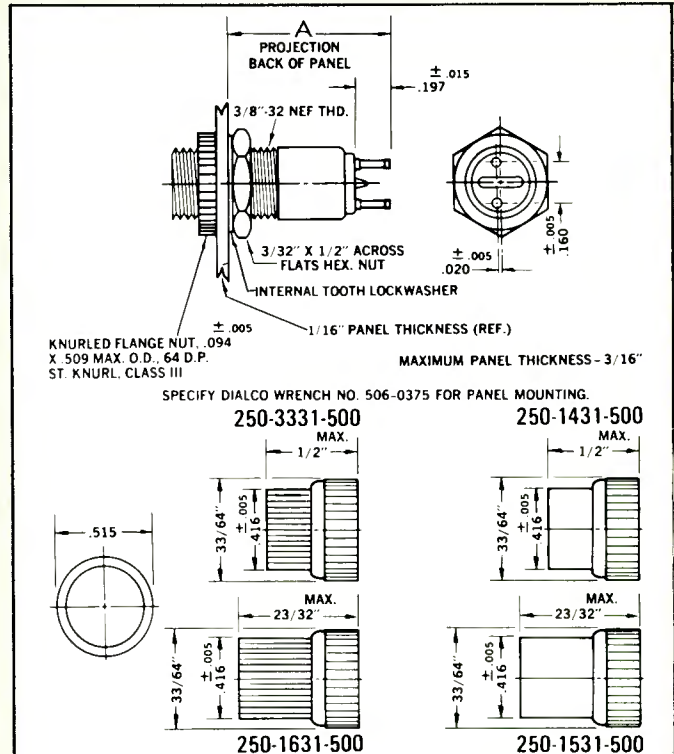

*DATA CAP LENS COLORS

1 - Red	5 - White
+2 - Green	(translucent)
3 - Yellow	6 - Lt. Yellow
(amber)	7 - Clear
+4 - Blue	(colorless)

* The catalog numbers in the large chart above designate complete indicators with red Data Cap. To obtain other colors, change the last digit in code block three. Example: 250-8738-1433-504 (Yellow Amber).

+ Blue and green are not recommended for use with neon.



Plug-in Lamp Cartridges

Covered by Military Specifications MS18235 through MS18238



507-3909-1471-600
MS18235-1RT



507-5338-0931-630
MS18236-1RN

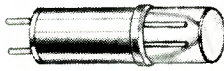

507-5337-1531-670
MS18237-2RN



507-6022-1437-600
MS18238-1

(Illust. approx. actual size.)

Incandescent Cylindrical Plug-in Lamp Cartridges								
Military Std. Drawing Nos.	Dialight Catalog Numbers	Finish	Lens Shape	Lens Color	Volts	mA	C.P.**	Life † Hours
MS18235-1RT	507-3909-1471-600	Translucent	Short Cyl.	Red	6.3	200	.40	50,000
MS18235-1GT	507-3909-1472-600	Translucent	Short Cyl.	Green	6.3	200	.40	50,000
MS18235-1YT	507-3909-1473-600	Translucent	Short Cyl.	Yellow (Amber)	6.3	200	.40	50,000
MS18235-1BT	507-3909-1474-600	Translucent	Short Cyl.	Blue	6.3	200	.40	50,000
MS18235-1WT	507-3909-1475-600	Translucent	Short Cyl.	White	6.3	200	.40	50,000
MS18235-1CN*	507-3909-1437-600	Non-Diffusing	Short Cyl.	Colorless (Clear)	6.3	200	.40	50,000
MS18235-2RT	507-3914-1471-600	Translucent	Short Cyl.	Red	14.0	80	.30	50,000
MS18235-2GT	507-3914-1472-600	Translucent	Short Cyl.	Green	14.0	80	.30	50,000
MS18235-2YT	507-3914-1473-600	Translucent	Short Cyl.	Yellow (Amber)	14.0	80	.30	50,000
MS18235-2BT	507-3914-1474-600	Translucent	Short Cyl.	Blue	14.0	80	.30	50,000
MS18235-2WT	507-3914-1475-600	Translucent	Short Cyl.	White	14.0	80	.30	50,000
MS18235-2CN*	507-3914-1437-600	Non-Diffusing	Short Cyl.	Colorless (Clear)	14.0	80	.30	50,000
MS18235-3RT	507-3918-1471-600	Translucent	Short Cyl.	Red	28.0	40	.30	25,000
MS18235-3GT	507-3918-1472-600	Translucent	Short Cyl.	Green	28.0	40	.30	25,000
MS18235-3YT	507-3918-1473-600	Translucent	Short Cyl.	Yellow (Amber)	28.0	40	.30	25,000
MS18235-3BT	507-3918-1474-600	Translucent	Short Cyl.	Blue	28.0	40	.30	25,000
MS18235-3WT	507-3918-1475-600	Translucent	Short Cyl.	White	28.0	40	.30	25,000
MS18235-3CN*	507-3918-1437-600	Non-Diffusing	Short Cyl.	Colorless (Clear)	28.0	40	.30	25,000

* Only incandescent lamp cartridges with clear (colorless) lens (-1CN, -2CN, -3CN) should be used with LH90/2 Indicator Light Housing, when combined with LC30 or LC32 lens cap. (See facing page for description of Indicator Light Housing and Lens Caps)

** C.P. is the mean spherical candle power of the bulb used. Values are useful for relative effectiveness.

† Theoretical design average.

INCANDESCENT: These plug-in lamp cartridges are accommodated by Military Type Designations LH87/1, LH90/1 (with collar) or LH90/2 (without collar). Incandescent plug-in cartridges are available at 6.3, 14 or 28 volts and are accommodated by the above noted housings. Similar incandescent cartridges (for 48 or 60 volt operation—see MS18238-1, -2 below) are accommodated by LH90/3 Housing only. Six lens colors are available at 6.3, 14 and 28 volts. The bulbs used in these lamp cartridges have low temperature filaments for long life performance. The 48 and 60 volt cartridges are clear colorless only.

NEON: These plug-in lamp cartridges are available with long cylindrical or stovepipe lens shapes, and are also accommodated by LH87/1, LH90/1 (with collar) and LH90/2 (without collar) Housings. High brightness neon cartridges are supplied with a built-in 33K current-limiting resistor for use on 110-125V AC only. Standard brightness neon cartridges are supplied with 100K resistors for 105-125V AC-DC operation.

The incandescent and neon lamp cartridges described above may also be accommodated by other appropriate housings described elsewhere in this catalog.

Materials and Finishes: See description on Page 4.

Note: The lamp cartridge will be marked with the basic MS number only regardless of lens color. They will also be marked with basic Dialight catalog number, voltage and ampere ratings in cases of Incandescent cartridges or resistance value in cases of Neon cartridges. Example:

DIALCO 507-3909 6.3V 200 ma. MS18235-1	DIALCO 507-5338 33K MS18236-1	DIALCO 507-5337 100K MS18237-2	DIALCO 507-6022 48V 53 ma. MS18238-1
---	--	---	---

Neon Cylindrical Plug-in Lamp Cartridges							
Neon Lamp 110-125V AC Only	Military Std. Drawing Nos.	Dialight Catalog Numbers	Finish	Lens Shape	Lens Color	Resistor	Approx. Life Hours
A1C High Brightness	MS18236-1RN	507-5338-0931-630	Non-Diffusing	Stovepipe	Red	33K	25,000
	MS18236-1YN	507-5338-0933-630	Non-Diffusing	Stovepipe	Yellow (Amber)	33K	25,000
	MS18236-1WT	507-5338-0935-630	Translucent	Stovepipe	White	33K	25,000
	MS18236-1CN	507-5338-0937-630	Non-Diffusing	Stovepipe	Colorless (Clear)	33K	25,000
A1C High Brightness	MS18237-1RN	507-5338-1531-630	Non-Diffusing	Long Cyl.	Red	33K	25,000
	MS18237-1YN	507-5338-1533-630	Non-Diffusing	Long Cyl.	Yellow (Amber)	33K	25,000
	MS18237-1WT	507-5338-1535-630	Translucent	Long Cyl.	White	33K	25,000
	MS18237-1CN	507-5338-1537-630	Non-Diffusing	Long Cyl.	Colorless (Clear)	33K	25,000

Neon Cylindrical Plug-in Lamp Cartridges							
Neon Lamp 105-125V AC-DC	Military Std. Drawing Nos.	Dialight Catalog Numbers	Finish	Lens Shape	Lens Color	Resistor	Approx. Life Hours
A1B Standard Brightness	MS18236-2RN	507-5337-0931-670	Non-Diffusing	Stovepipe	Red	100K	15,000
	MS18236-2YN	507-5337-0933-670	Non-Diffusing	Stovepipe	Yellow (Amber)	100K	15,000
	MS18236-2WT	507-5337-0935-670	Translucent	Stovepipe	White	100K	15,000
	MS18236-2CN	507-5337-0937-670	Non-Diffusing	Stovepipe	Colorless (Clear)	100K	15,000
A1B Standard Brightness	MS18237-2RN	507-5337-1531-670	Non-Diffusing	Long Cyl.	Red	100K	15,000
	MS18237-2YN	507-5337-1533-670	Non-Diffusing	Long Cyl.	Yellow (Amber)	100K	15,000
	MS18237-2WT	507-5337-1535-670	Translucent	Long Cyl.	White	100K	15,000
	MS18237-2CN	507-5337-1537-670	Non-Diffusing	Long Cyl.	Colorless (Clear)	100K	15,000

Incandescent Cylindrical Plug-in Lamp Cartridges								
Military Std. Dwg. Numbers +	Dialight Catalog Numbers	Lens Shape	Finish	Lens Color	Volts	mA	C.P.**	Life Hours
MS18238-1	507-6022-1437-600	Short Cylindrical	Non-Diffusing	Colorless (Clear)	48	53	.52	5,000
MS18238-2	507-6023-1437-600	Short Cylindrical	Non-Diffusing	Colorless (Clear)	60	50	.67	5,000

+ These cartridges are accommodated by LH90/3 Housing only. When the assembly includes lens cap, only the LC30 Type Designation should be specified.

** C.P. is the mean spherical candle power of the bulb used. Values are useful for relative effectiveness.

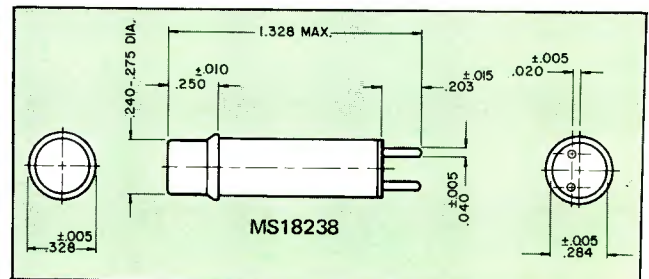
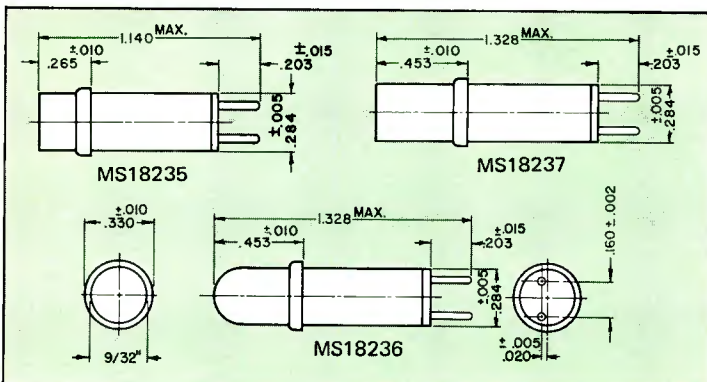

Datalites® Covered by Mil-L-3661B

Designed to Accommodate Cylindrical Plug-in Lamp Cartridges

(Illustr. approx. actual size.)

Indicator lights in this series consist of the Housing (base assembly) designed for mounting in 3/8" clearance hole on panels up to 3/16" thick. Style LH90/1 is provided with collar, and accommodates MS18235, MS18236 and MS18237 plug-in lamp cartridges described on Page 12. Housing styles LH90/2 and LH90/3 are furnished without collar. LH90/2 may be used with LC30 or LC32 lens cap. LH90/3 should only be used with LC30. The LH90/2 housing, when used with a lens cap, will accommodate only the MS18235 cartridge.

Housing LH90/1 and LH90/2 also accommodate other plug-in lamp cartridges described elsewhere in this catalog.

The lens caps are offered in a choice of five colors. Translucent caps permit use of hot-stamped or engraved legend markings.

Materials and Finishes: See description on Page 10 to 11.

Legend Markings: See description on Page 19.

Note: Only the type designation for the Indicator-Light Housing will be marked on the assembly. There will be no marking on the Indicator-Light Lens (e.g. DIALCO LH90/2).

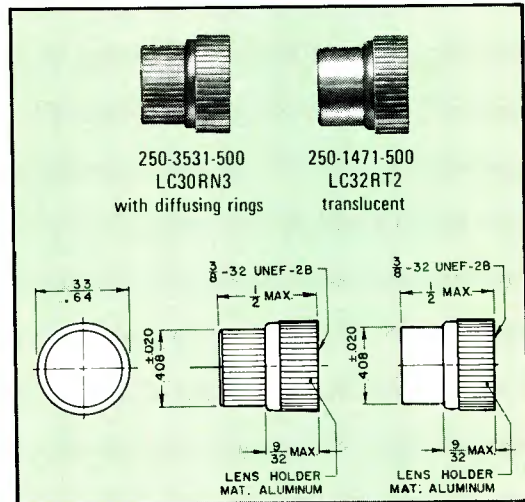
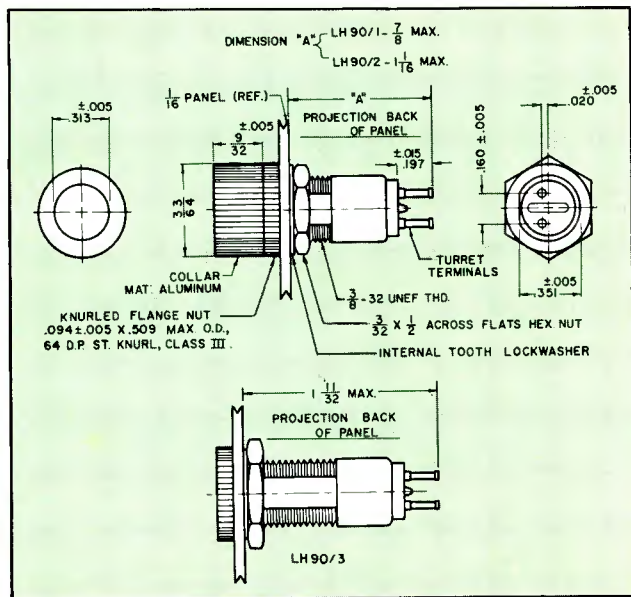
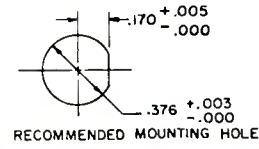
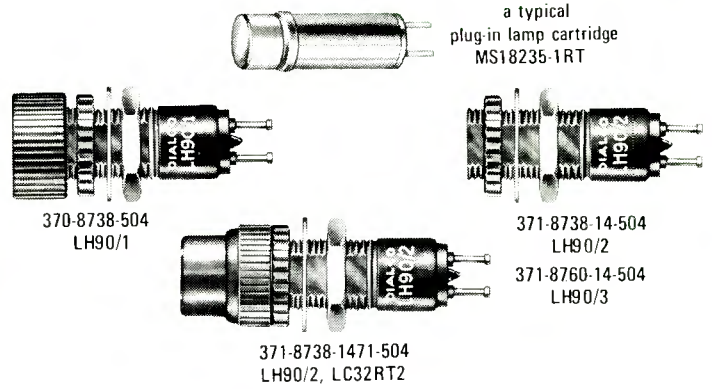

Housings, Indicator Light, Style LH90	
Type Designations	Dialight Catalog Nos.
LH90/1*	370-8738-504
+ LH90/2*	371-8738-14-504
+ LH90/3**	371-8760-14-504

* Accommodate MS plug in lamp cartridges on Page 12 (with exception of MS18238).
 ** Accommodate MS18238 plug-in lamp cartridges only.
 + No collar shall be furnished.

Lens Cap Type Designation ▲	With LH90/2 Housing	With LH90/3 Housing
	Complete Catalog Number □	Complete Catalog Number ■ □
LC30RN3	371-8738-3531-504	371-8760-3531-504
LC30GN3	371-8738-3532-504	371-8760-3532-504
LC30YN3	371-8738-3533-504	371-8760-3533-504
LC30BN3	371-8738-3534-504	371-8760-3534-504
LC30WT3	371-8738-3535-504	371-8760-3535-504
LC32RT2	371-8738-1471-504	_____
LC32GT2	371-8738-1472-504	_____
LC32YT2	371-8738-1473-504	_____
LC32BT2	371-8738-1474-504	_____
LC32WT2	371-8738-1475-504	_____

- LH90/3 housing accommodates MS18238 plug-in cartridge only, and is not to be used with LC32 lens cap.
- Assemblies, with lens caps, are not available for use with MS18236 and MS18237 neon plug-in cartridges.
- ▲ Lens caps (offered in a choice of 5 colors), may only be used with incandescent plug-in lamp cartridges having clear colorless lenses.

Lenses, Indicator Light, Styles LC30, LC32			
Type Designations	Dialight Catalog Nos.	Finish	Color
LC30RN3	250-3531-500	Non-Diffusing	Red
LC30GN3	250-3532-500	Non-Diffusing	Green
LC30YN3	250-3533-500	Non-Diffusing	Yellow (Amber)
LC30BN3	250-3534-500	Non-Diffusing	Blue
LC30WT3	250-3535-500	Non-Diffusing	White
LC32RT2	250-1471-500	Translucent	Red
LC32GT2	250-1472-500	Translucent	Green
LC32YT2	250-1473-500	Translucent	Yellow (Amber)
LC32BT2	250-1474-500	Translucent	Blue
LC32WT2	250-1475-500	Translucent	White



Twin Lamp Datalites®

Covered by Mil-L-3661B

Designed to Accommodate Two Cylindrical Plug-in Lamp Cartridges

(Illustrations are approx. actual size. Dimensions are average values.)

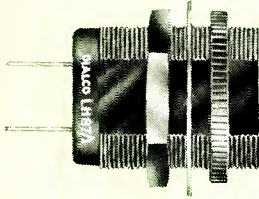

365-6939-14-504
LH87/1

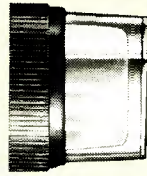

253-1437-500
LC31CN2

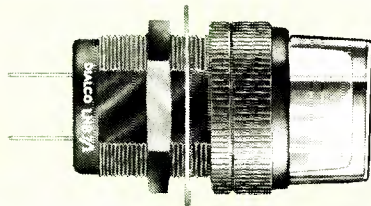

365-6939-1437-504
LH87/1, LC31CN2

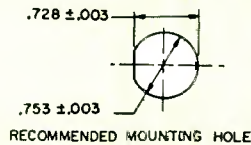

Housing, Indicator Light, Style LH87/1	
Type Designation	Dialight Catalog Number
LH87/1*	365-6939-14-504

*Not for use with MS18238 incandescent plug-in lamp cartridges.

This indicator light accommodates two lamps which may be operated independently or simultaneously. It consists of a dual lamp indicator light housing (LH87/1) and a lens cap (LC31). The lens cap is divided into two sections by an aluminum light barrier. Lens caps can be supplied either light white translucent or clear colorless (non-diffusing).

The required plug-in lamp cartridges (two) are ordered separately (exception: MS18238 cartridges cannot be used with this assembly). The clear colorless (non-diffusing) lens is suitable for either incandescent or neon lamp cartridges.

Materials and Finishes: See description on Pages 10-11.

Note: Only the type designation for the Indicator-Light Housing will be marked on the assembly. There will be no marking on the Indicator-Light Lens (e.g. DIALCO LH87/1).

HOUSING, INDICATOR LIGHT, STYLE LH87/1

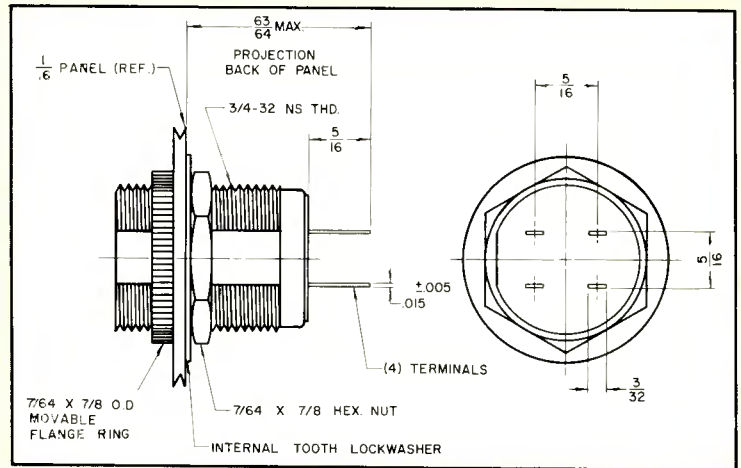

Lenses, Indicator Light, Style LC31

Type Designations	Dialight Catalog Nos.	Finish	Color
LC31WT2	253-1435-500	Translucent	White
LC31CN2	253-1437-500	Non-Diffusing	Colorless (Clear)

Lens Cap Type Designation	With LH87/1 Housing	
	Type Designation	Complete Catalog Number
LC31WT2		365-6939-1435-504
LC31CN2		365-6939-1437-504

LENSES, INDICATOR LIGHT, STYLE LC31

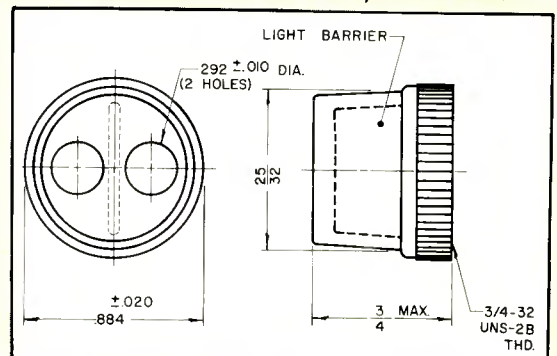

ultra-miniature Indicator Lights with solid-state **DIODE-LITES™**

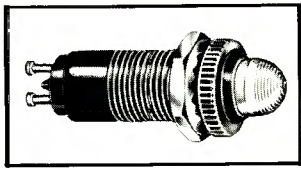

(Illustrations are approx. actual size. Dimensions are average values.)

FEATURES

- LOW POWER REQUIREMENTS
- INTEGRATED CIRCUIT COMPATIBILITY
- SOLID STATE RELIABILITY
- IMMUNE TO SHOCK AND VIBRATION
- OPERATING TEMPERATURES – 55° C TO + 60° C
- TRANSIENT FREE SWITCHING

The 249 Series solid state indicator is a complete package – light source, housing and lens – ready for permanent panel mounting.

The light source is a solid state lamp that provides the advantages of **low power** with extremely **long life**, **reliability** measured in years, and is compatible with integrated circuits (can be driven directly by RTL, DTL and TTL Logic).

OPERATING VOLTAGES: The 249 Series indicators with solid-state DIODE-LITES™ is available in a range of voltages from 3.6 to 28V DC at a maximum current of 20 mA. Tolerances on the DC voltage should be within 5% of the specified voltage.



UNIQUE LENS DESIGN: Dialight uses an internal fresnel ring pattern in its lens design. This assures maximum distribution of the light output from the DIODE-LITE™. The lens area is completely flooded with light.

MAXIMUM CONTRAST: The indicator is supplied in a black anodized finish (standard) which produces a high contrast ratio. Such a ratio is desirable for optimum indication.

POLARITY: To facilitate proper installation of the indicator, the terminal marked “+” denotes positive polarity.

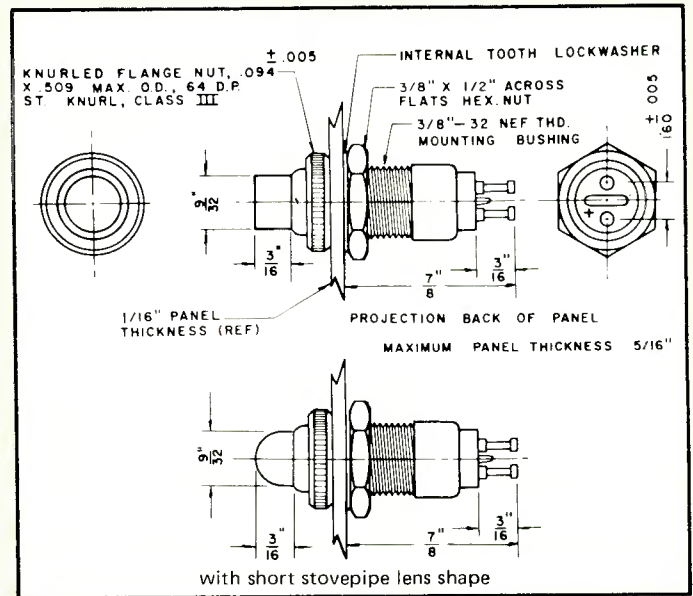
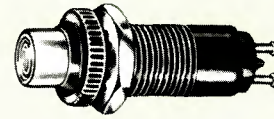

MATERIALS AND FINISHES

- **Mounting bushing and flange ring:** Standard – Aluminum, black anodized finish. Optional – clear anodize finish.
- **Mounting nut:** Brass, white nickel finish.
- **Internal-tooth Lockwasher:** Phosphor bronze, white nickel finish.
- **Terminals:** Low carbon steel, solder plated.
- **Lens:** High strength plastic. Internal fresnel ring pattern.

Ordering Information

20mA INDICATOR LIGHTS WITH SHORT CYLINDRICAL LENS SHAPE – WITH FRESNEL RINGS ☆							
	TRANSPARENT LENS COLOR	3.6V DC	5V DC	6V DC	10V DC	14V DC	28V DC
WITH RED LED	Red	249-7867-3331-504	249-7868-3331-504	249-7869-3331-504	249-7870-3331-504	249-7871-3331-504	249-7872-3331-504
	White	249-7867-3335-504	249-7868-3335-504	249-7869-3335-504	249-7870-3335-504	249-7871-3335-504	249-7872-3335-504
	Clear	249-7867-3337-504	249-7868-3337-504	249-7869-3337-504	249-7870-3337-504	249-7871-3337-504	249-7872-3337-504
WITH GREEN LED	Green	249-7967-3332-504	249-7968-3332-504	249-7969-3332-504	249-7970-3332-504	249-7971-3332-504	249-7972-3332-504
	White	249-7967-3335-504	249-7968-3335-504	249-7969-3335-504	249-7970-3335-504	249-7971-3335-504	249-7972-3335-504
	Clear	249-7967-3337-504	249-7968-3337-504	249-7969-3337-504	249-7970-3337-504	249-7971-3337-504	249-7972-3337-504
WITH YELLOW LED	Yellow (amber)	249-8067-3333-504	249-8068-3333-504	249-8069-3333-504	249-8070-3333-504	249-8071-3333-504	249-8072-3333-504
	White	249-8067-3335-504	249-8068-3335-504	249-8069-3335-504	249-8070-3335-504	249-8071-3335-504	249-8072-3335-504
	Clear	249-8067-3337-504	249-8068-3337-504	249-8069-3337-504	249-8070-3337-504	249-8071-3337-504	249-8072-3337-504

☆ To obtain indicators with short stovepipe lens shape, change the first two digits in the 3rd code block from 33 to 37. Examples: 249-7968-3732-504; 249-8070-3737-504.

NOTE: The catalog numbers in this chart designate indicators with standard black anodize finish. To specify optional clear anodize finish, change the 5 in the catalog number suffix to 6. Example: 249-7869-3331-604.

permanent lamp Indicator Lights

It is possible to provide indicator lights of very small dimensions, that may be applied directly to commercial voltage circuits when T-2 neon lamps are used as the light sources.

These neon glow lamps are very uniform in their performance and exceptionally free of early failures. When recommended series resistors are used, very long minimum life ratings apply. High lamp reliability makes it reasonable to offer these lights with non-replaceable lamps.

Lamp C2A (NE-2H) is used in these lights for all applications on 110-125 volts, alternating current. The necessary current-limiting

resistor is built into the light housing so that the full voltage may be applied to the terminals. Two levels of operation are provided by the choice of the resistor value—either 22K or 33K ohms. Higher light output is provided by the 22K option and minimum life is still long—5,000 hours. For DC circuits of 105-125 volts, the neon lamp used is A9A (NE-2E). Even lower voltages may be accommodated by the use of selected lamps. Data will be provided on application.

The tables on the facing page show recommended resistor values, and how to designate the three-digit catalog number suffix.

(Illustrations are approx. actual size. Dimensions are average values.)

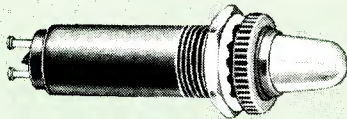

249-7866-0931-514

MOUNT FROM REAR IN 3/8" CLEARANCE HOLE

WITH BUILT-IN RESISTOR

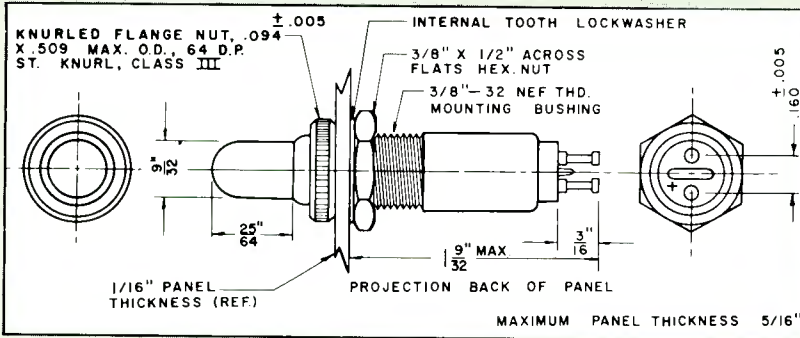

In this series of assemblies, the non-replaceable neon lamp is combined with a built-in current-limiting resistor. Indicator lights are offered with a choice of stovepipe, flat or short cylindrical lens. The latter two may be hot-stamped or engraved if desired. See "Hot-Stamped or Engraved Legends" on Page 19.

See "Recommended Resistance Values" and "How to Designate the Three-Digit Catalog Number Suffix" on the facing page.

See "Materials and Finishes" on facing page.

Hot-Stamped or Engraved Legends: See description on Page 19.

PERMANENT LAMP INDICATOR LIGHTS WITH BUILT-IN RESISTOR

Lens Color	With Stovepipe Lens Shape		With Short Cylindrical Lens Shape		With Flat Lens Shape	
	Standard Brightness 56K*	High Brightness 22K*	Standard Brightness 56K*	High Brightness 22K*	Standard Brightness 56K*	High Brightness 22K*
Red	249-7841-0931-544	249-7866-0931-514	249-7841-1431-544	249-7866-1431-514	249-7841-0331-544	249-7866-0331-514
Yellow (Amber)	249-7841-0933-544	249-7866-0933-514	249-7841-1433-544	249-7866-1433-514	249-7841-0333-544	249-7866-0333-514
White (Translucent)	249-7841-0935-544	249-7866-0935-514	249-7841-1435-544	249-7866-1435-514	249-7841-0335-544	249-7866-0335-514
Clear (Colorless)	249-7841-0937-544	249-7866-0937-514	249-7841-1437-544	249-7866-1437-514	249-7841-0337-544	249-7866-0337-514

*See recommended resistance values and appropriate catalog number designations on facing page.

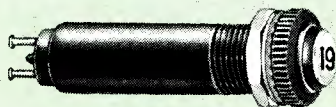

249-7866-0331-514

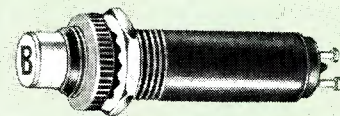

249-7841-1431-544

WITH BUILT-IN RESISTOR

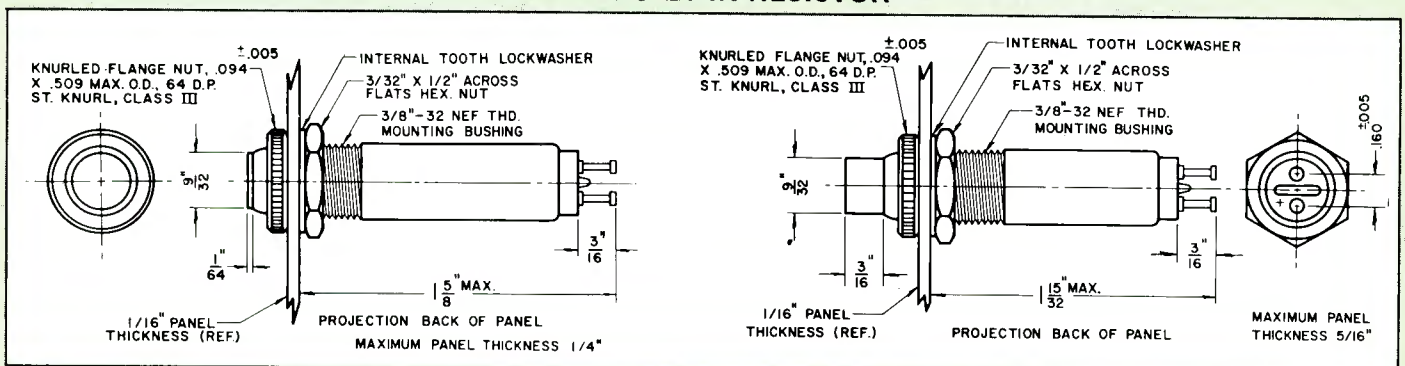

permanent lamp Indicator Lights with Neon Lamps

WITH DATA CAPS

WITH OR WITHOUT BUILT-IN RESISTOR

MOUNT FROM REAR IN 3/8" CLEARANCE HOLE

The permanent Lamp Indicator Lights described on this page are provide with an "outer" screw-on Data Cap. This cap may be rotated for alignment of legend after installation.

Note: For those assemblies offered without built-in resistor, it is necessary to add the recommended current-limiting resistor externally.

(Illustr. approx. actual size.
Dimensions are average values.)

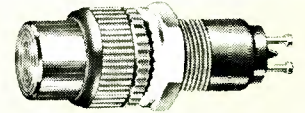

250-7840-3331-504
WITH NO BUILT-IN RESISTOR

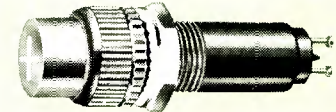

250-7866-1431-514
WITH BUILT-IN RESISTOR

MATERIALS AND FINISHES

- Mounting bushing, flange ring, lens holder and collar: Aluminum, black anodize finish. Optional—clear anodize finish.
- Mounting nut: Brass, white nickel finish.
- Internal-tooth lockwasher: Phosphor bronze, white nickel finish.
- Terminals: Low carbon steel, solder plated.

SAMPLES ON REQUEST—
AT ONCE—NO CHARGE

PERMANENT LAMP INDICATOR LIGHTS WITHOUT BUILT-IN RESISTOR

Data Cap Lens Colors	Standard Brightness		High Brightness		Data Cap Assemblies	
	Transparent Lens	Lens With Refractive Inner Surfaces	Transparent Lens	Lens With Refractive Inner Surfaces	Transparent	With Refractive Surfaces
Red	250-7840-1431-504	250-7840-3331-504	250-7865-1431-504	250-7865-3331-504	250-1431-500	250-3331-500
Yellow (Amber)	250-7840-1433-504	250-7840-3333-504	250-7865-1433-504	250-7865-3333-504	250-1433-500	250-3333-500
White (Translucent)	250-7840-1435-504	250-7840-3335-504	250-7865-1435-504	250-7865-3335-504	250-1435-500	250-3335-500
Clear (Colorless)	250-7840-1437-504	250-7840-3337-504	250-7865-1437-504	250-7865-3337-504	250-1437-500	250-3337-500
Base Assembly	250-7840-14-504		250-7865-14-504		—	—

PERMANENT LAMP INDICATOR LIGHTS WITH BUILT-IN RESISTOR

Data Cap Lens Colors	Standard Brightness—56K*		High Brightness—22K*		Data Cap Assemblies	
	Transparent Lens	Lens With Refractive Inner Surfaces	Transparent Lens	Lens With Refractive Inner Surfaces	Transparent	With Refractive Surfaces
Red	250-7841-1431-544	250-7841-3331-544	250-7866-1431-514	250-7866-3331-514	250-1431-500	250-3331-500
Yellow (Amber)	250-7841-1433-544	250-7841-3333-544	250-7866-1433-514	250-7866-3333-514	250-1433-500	250-3333-500
White (Translucent)	250-7841-1435-544	250-7841-3335-544	250-7866-1435-514	250-7866-3335-514	250-1435-500	250-3335-500
Clear (Colorless)	250-7841-1437-544	250-7841-3337-544	250-7866-1437-514	250-7866-3337-514	250-1437-500	250-3337-500
Base Assembly	250-7841-14-544		250-7866-14-514		—	—

*For other resistance values, change the second digit in the catalog number suffix. See chart on Page 17 with recommended resistance values and appropriate catalog number designations.

WITHOUT BUILT-IN RESISTOR

WITH BUILT-IN RESISTOR

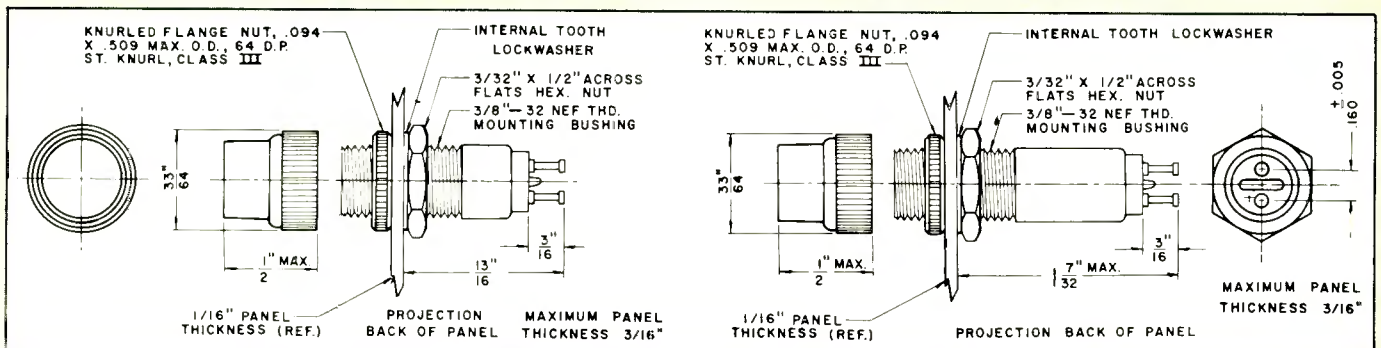

509 series Datalamp Holder

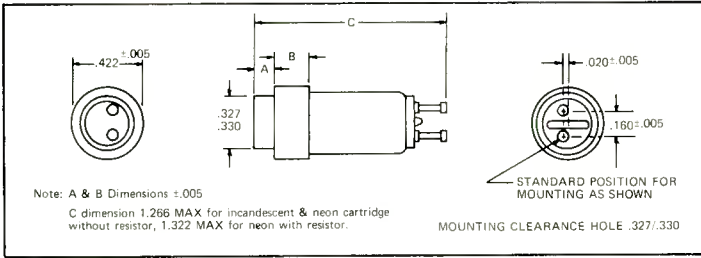

Ordering Information

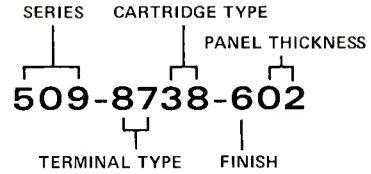

Closely spaced arrangements of many indicator lights are possible with the use of these holders mounted permanently (swaged)* to a panel or strip. Center to center spacing can be measured from 7/16" up, with 1/2" recommended as an optimum standard. Holders can be supplied for use with either neon, incandescent or LED cartridges, and with turret terminals (illus), solder cup or solder blade terminals or AMP "53" taper pin receptacles.

* Tool kit available for manual mounting of holders.
Dialight part no. 506-0509.

Materials and Finishes

- Mounting bushing** — Aluminum, clear anodize finish, black anodize optional.
- Terminals** — Phosphor bronze, nickel flash and gold plated, except solder blade, — phosphor bronze with fused tin finish.
- Header** — Phenolic, type CFG.

Terminal Type

- 87 — Turret
- 75 — Solder Cup
- 74 — Solder Blade
- 90 — AMP "53"

Cartridge Type

- 38 — Incandescent or neon w/o built-in resistor
- 45 — Neon only, with built-in resistor

Finish

- 6 — Clear anodize
- 5 — Black anodize

Panel Thickness

	DIM. A	DIM. B
02 — 1/16"	.099	.218
03 — 3/32"	.126	.218
04 — 1/8"	.161	.218
06 — 3/16"	.225	.155

HOT-STAMPED OR ENGRAVED LEGENDS

Datalamp Standard Character Sizes			Data Cap Standard Character Sizes		
One Line	Two Lines	Size	One Line	Two Lines	Size
XXX	XX XX	5/64"	XXXX	XXX XXX	5/64"
XX		7/64"	XXX	XX XX	7/64"
X		11/64"	XX		11/64"
			X		13/64"

ORDERING CUSTOM LEGEND MARKINGS

While not recommended, Datalamp cartridges (with short or long cylindrical lens shape) can be hot-stamped or engraved. Lamp failure requires replacement of the Datalamp with another with identical hot-stamping. As a result, spares must be kept on hand to reduce replacement procurement time.

It is recommended that Data Caps be used. Only clear colorless Datalamp cartridges (without legends) are required, with a hot-stamped or engraved "outer" Data Cap. Down time is greatly reduced, since the cartridge can be quickly replaced and the Data Cap repositioned over the Datalamp.

Select a color for the lighted lens which provides a good background for the desired legend. Use of white or amber is recommended for best contrast (and legibility) lighted or unlighted. **Standard marking color is black** for best contrast on these colors.

Red, green and blue translucent colors are useful with higher powered Datalamps. Red is good, green is fair and blue has the lowest luminosity. Specify the precise marking (legend) to be applied. (See description to the left.) Legends will be furnished in a uniform manner—i.e., the size of type will be determined by the largest legend indicated in each individual order unless otherwise specified.

ENGRAVED LEGENDS (For Negative Legend Presentations only).

Translucent colored markings can be furnished on Datalamp or Data Cap lenses with black or gray opaque overlay. As a result, legends may be had in "negative" or "reverse" style.

The legend is illuminated in white (or other color) while the background remains opaque black or gray. For example, to obtain a green legend on a black background, a green translucent lens is sprayed black, then engraved through to the green lens surface. When lighted, the green marking is seen surrounded by opaque black color.

DIALIGHT

203 Harrison Place, Brooklyn, N.Y. 11237
Phone: (212) 497-7600
TWX: 710-584-5487



CURRENT LITERATURE

	catalog number	check here
INDICATOR LIGHTS		
Sub-Sub-Miniature.....	L-168.....	<input type="checkbox"/>
Ultra-Miniature.....	UM-1200.....	<input type="checkbox"/>
Sub-Miniature		
● One Terminal.....	L-157.....	<input type="checkbox"/>
● Edge lighting for Plastic Plates.....	L-158.....	<input type="checkbox"/>
● Two Terminals.....	L-178.....	<input type="checkbox"/>
Miniature, Large & Misc.		
● Digest of Indicator Lights.....	L-161.....	<input type="checkbox"/>
● Flashing Indicators.....	L-211.....	<input type="checkbox"/>
Oil-Tight	L-200.....	<input type="checkbox"/>
Press-to-Test	L-201.....	<input type="checkbox"/>
Placard Lights	L-170.....	<input type="checkbox"/>
Cross Reference of Dialight Catalog		
Numbers to Military Type Designations & MS Drawings.....	CR740.....	<input type="checkbox"/>
Also available		
Switch Product Selector Guide.....	L-210.....	<input type="checkbox"/>
554 Series Illuminated Push Button Switch.....	SW6130.....	<input type="checkbox"/>
Readout Product Selector Guide.....	SG742.....	<input type="checkbox"/>
LED Product Selector Guide.....	SG751.....	<input type="checkbox"/>
Indicator Light Product Selector Guide.....	SG750.....	<input type="checkbox"/>

Send for your copies of these Catalogs.



INDICATOR LIGHTS



DIALIGHT

Sub-Miniature

*Indicator Lights • one terminal—fully insulated
for use on grounded circuits*



A NORTH AMERICAN PHILIPS COMPANY

CATALOG L-157E
April 1973



INCANDESCENT INDICATOR LIGHTS

ONE TERMINAL—FULLY INSULATED

MEET OR EXCEED ENVIRONMENTAL AND OPERATIONAL REQUIREMENTS

OF MIL-L-7806 AND MIL-L-3661.

LIGHT SOURCE

All sub-miniature indicator lights described in this catalog are intended to be used with T-1 3/4 bulb with midjet flanged base.



MATERIALS AND FINISHES

(All Series, unless otherwise noted)

- **Mounting Bushing:** Standard—Brass, black nickel finish. Optional—Polished chrome or white nickel.
- **Mounting Nut:** Brass, white nickel finish.
- **Internal-tooth Lockwasher:** Phosphor bronze, white nickel finish.
- **Terminals:** **Soldering**—Brass, hot tin dip.
Screw—Brass, cadmium plated with yellow iridescent chromate finish.
- **Insulation:** Per MIL-L-7806.

MANUFACTURER'S RATINGS

(Values given are approx.)

LAMP NO.	VOLTS	AMPERES	HOURS	CANDLE POWER
331	1.35	.06	5,000	.006
338	2.7	.06	6,000	.04
375	3.0	.015	20,000	.004
7332	5.0	.06	30,000	.05
*328	6.0	.20	1,000	.63
345	6.0	.04	1,000	.03
349	6.3	.20	5,000	.55
380	6.3	.04	20,000	.02
381	6.3	.20	20,000	.40
344	10.0	.014	25,000	.002
367	10.0	.04	10,000	.08
330	14.0	.08	1,500	.50
382	14.0	.08	15,000	.30
370	18.0	.04	10,000	.15
*327	28.0	.04	4,000	.34
**387	28.0	.04	7,000	.30

*Conforms to MS25237

**MS18209 (BuShips)

■ Ratings of lamps are taken from published catalogs of leading lamp manufacturers.

Rated life is generally recognized as the 50% failure point of a group of lamps tested under static laboratory conditions, with the voltage closely regulated at the design value. This may not necessarily agree with the service life of a lamp where the effects of temperature, shock, vibration and voltage fluctuations may result in a shorter than rated life.

TWO TERMINAL SUB-MINIATURE INDICATOR LIGHTS: Dialco also makes a series of two terminal, completely insulated sub-miniatures for use on ungrounded circuits. Ask for **Catalog L-178**.

INDICATOR LIGHTS with OMNIDIRECTIONAL LENSES

MOUNT FROM FRONT OF PANEL IN 13/32" OR 15/32" CLEARANCE HOLE

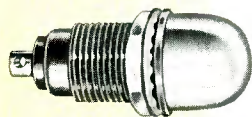

101-4630-0931-201

The plastic dome lens shape provides 180° all angle visibility. The metal insert reinforces and holds the lamp. The lens cap assembly unscrews for easy lamp replacement from front of panel.

OPTIONAL FINISHES

NOTE: The catalog number suffix designates an assembly with standard black nickel finish. To specify optional finish (where applicable), change the first digit of the catalog number suffix to -1 (white nickel finish) or -3 (polished chrome finish).

Examples: 101-4630-0931-101 (white nickel finish); 101-4630-0931-301 (polished chrome finish).

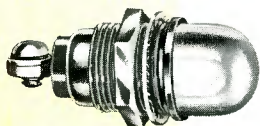

107-1830-0931-201

FOR MOUNTING IN 13/32" CLEARANCE HOLE

PLASTIC LENS TYPE	LENS FINISH	COMPLETE ASSEMBLY WITH 1 SOLDERING TERMINAL	COMPLETE ASSEMBLY WITH 1 SCREW TERMINAL	LENS CAP ASSEMBLY
Stovepipe	Transparent	101-4630-0931-201	101-7130-0931-201	101-0931
	Translucent	101-4630-0971-201	101-7130-0971-201	101-0971
Base Assembly	—	101-4630-09-201	101-7130-09-201	—

FOR MOUNTING IN 15/32" CLEARANCE HOLE

PLASTIC LENS TYPE	LENS FINISH	COMPLETE ASSEMBLY WITH 1 SOLDERING TERMINAL	COMPLETE ASSEMBLY WITH 1 SCREW TERMINAL	LENS CAP ASSEMBLY
Stovepipe	Transparent	107-1930-0931-201	107-1830-0931-201	107-0931
	Translucent	107-1930-0971-201	107-1830-0971-201	107-0971
Base Assembly	—	107-1930-09-201	107-1830-09-201	—

LENS COLOR: See description on Page 3.

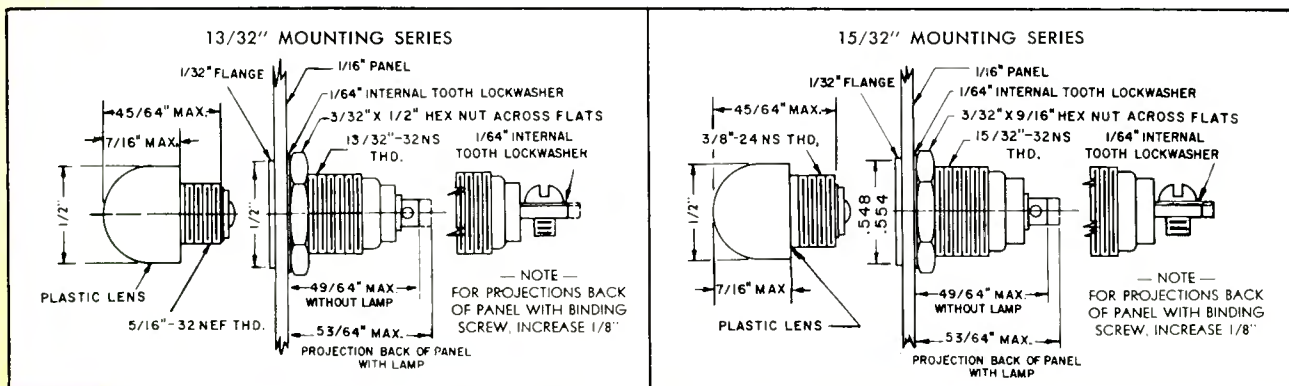

SAMPLES ON REQUEST AT ONCE—NO CHARGE

DIALIGHT
MANUFACTURERS OF VISUAL INDICATORS

CORPORATION

60 STEWART AVENUE • BROOKLYN, N.Y. 11237 • 212 497-7600 • TWX: 710-584-5487

A NORTH AMERICAN PHILIPS COMPANY

NON-DIMMING INDICATOR LIGHTS

MOUNT FROM FRONT OF PANEL IN 13/32" OR 15/32" CLEARANCE HOLE



FOR MOUNTING IN 13/32" CLEARANCE HOLE

TERMINAL TYPE	LENS FINISH	COMPLETE ASSEMBLY	LENS CAP ASSEMBLY
Soldering	Frosted Back	111-4630-0111-201	111-0111-200
	Unfrosted	111-4630-0131-201	111-0131-200
BASE ASSEMBLY		101-4630-09-201	
Screw	Frosted Back	111-7130-0111-201	111-0111-200
	Unfrosted	111-7130-0131-201	111-0131-200
BASE ASSEMBLY		101-7130-09-201	

A rugged, general purpose indicator light series with brass lens holder and glass lens. The lens cap assembly unscrews for easy lamp replacement from the front of panel. These assemblies mount in panels up to 3/8" thick.

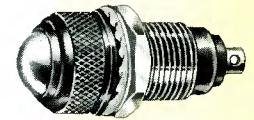

111-4630-0111-201

OPTIONAL FINISHES

NOTE: The catalog number suffix designates an assembly with standard black nickel finish. To specify optional finish (where applicable), change the first digit of the catalog number suffix to -1 (white nickel finish) or -3 (polished chrome finish).



8-1830-0111-201

Examples: 8-1930-0111-101 (white nickel finish); 111-4630-0131-301 (polished chrome finish).

FOR MOUNTING IN 15/32" CLEARANCE HOLE

TERMINAL TYPE	LENS FINISH	COMPLETE ASSEMBLY	LENS CAP ASSEMBLY
Soldering	Frosted Back	8-1930-0111-201	8-0111-200
	Unfrosted	8-1930-0131-201	8-0131-200
BASE ASSEMBLY		8-1930-01-201	
Screw	Frosted Back	8-1830-0111-201	8-0111-200
	Unfrosted	8-1830-0131-201	8-0131-200
BASE ASSEMBLY		8-1830-01-201	

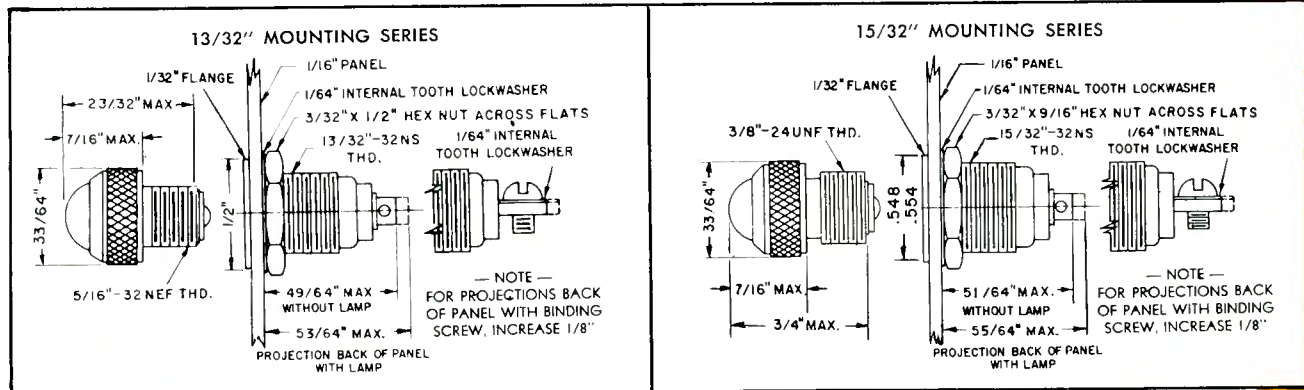

DIMMING INDICATOR LIGHTS (Mechanical or Polaroid)

MOUNT FROM FRONT OF PANEL IN 15/32" CLEARANCE HOLE

Choice of mechanical or polaroid dimming device. Polaroid produces some reduced intensity at all settings, but gives full diameter opening.

Mechanical varies opening size to complete blackout or has permanent small opening as in "semi-blackout" type.

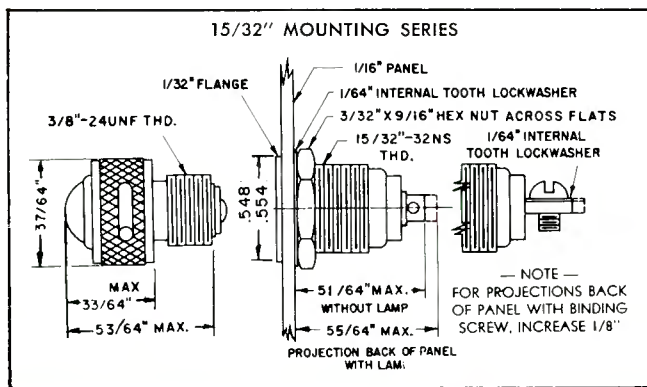

LENS COLOR: The last digit before the 3 digit catalog number suffix indicates that the lens is RED. When a color other than red is desired, change this digit to a figure from the listing below. Note that white lenses are translucent and are always furnished unfrosted.

Red-1; Green-2; Yellow (Amber)-3; Blue-4; White Translucent-5; Light Yellow-6; Clear (Colorless)-7.

Example: 2-1930-0114-201 (Blue)

Standard Finish: Black Nickel.

No options available.



2-1930-0111-201



11-1830-0111-201

FOR MOUNTING IN 15/32" CLEARANCE HOLE

TERMINAL TYPE	LENS FINISH	DIMMER TYPE			SEMI-BLACKOUT LENS CAP ASSEMBLY	COMPLETE BLACKOUT LENS CAP ASSEMBLY	POLAROID LENS CAP ASSEMBLY
		SEMI-BLACKOUT	COMPLETE BLACKOUT	POLAROID			
Soldering	Frosted Back	2-1930-0111-201	11-1930-0111-201	3-1930-0111-201	2-0111-200	11-0111-200	3-0111-200
	Unfrosted	2-1930-0131-201	11-1930-0131-201	3-1930-0131-201	2-0131-200	11-0131-200	3-0131-200
BASE ASSEMBLY		8-1930-01-201					
Screw	Frosted Back	2-1830-0111-201	11-1830-0111-201	3-1830-0111-201	2-0111-200	11-0111-200	3-0111-200
	Unfrosted	2-1830-0131-201	11-1830-0131-201	3-1830-0131-201	2-0131-200	11-0131-200	3-0131-200
BASE ASSEMBLY		8-1830-01-201					

SAMPLES ON REQUEST AT ONCE-NO CHARGE

DIALIGHT
MANUFACTURERS OF VISUAL INDICATORS

CORPORATION

60 STEWART AVENUE • BROOKLYN, N.Y. 11237 • 212 497-7600 • TWX: 710-584-5487

A NORTH AMERICAN PHILIPS COMPANY



INDICATOR LIGHTS with FLAT CYLINDRICAL LENSES

PERMIT USE OF HOT-STAMPED OR ENGRAVED LEGENDS

The lens cap assembly is a 2-piece unit, consisting of (1) **Plastic lens** moulded to a brass cap which fits over (2) **Friction-fit** slotted holder. Thus, the lens is rotatable and facilitates the alignment of the legend—after installation of the indicator light.

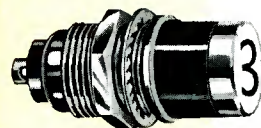

106-1930-0375-201



106-1830-0375-201

SIZE OF TYPE FOR LEGENDS (Flat lens only)

Number of Characters	Character Height Nearest Fraction	Type Size
ONE	13/64"	18 pt.
TWO	11/64"	14 pt.
THREE	9/64"	12 pt.
FOUR	5/64"	8 pt.

STANDARD: Black letters. White, red, green, blue or silver can be supplied on request.

Unless otherwise specified, these standard sizes will be provided in a uniform manner per order—i.e., the size of type will be determined by the largest legend in each individual order.

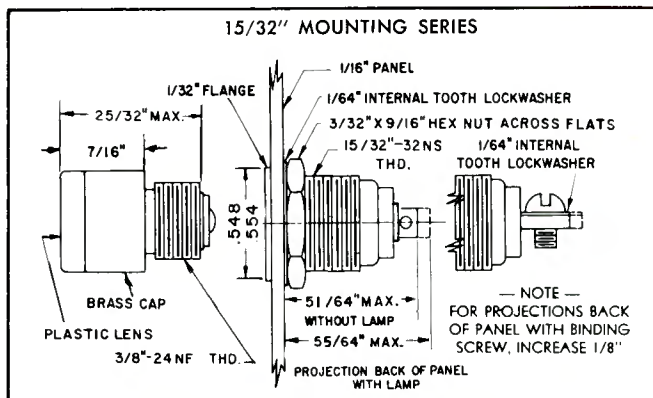

FOR MOUNTING IN 15/32" CLEARANCE HOLE

TRANSLUCENT PLASTIC	COMPLETE ASSEMBLY WITH 1 SOLDERING TERMINAL	COMPLETE ASSEMBLY WITH 1 SCREW TERMINAL	LENS CAP ASSEMBLY
Red	106-1930-0351-201	106-1830-0351-201	106-0351-200
Green	106-1930-0352-201	106-1830-0352-201	106-0352-200
Amber	106-1930-0373-201	106-1830-0373-201	106-0373-200
Blue	106-1930-0374-201	106-1830-0374-201	106-0374-200
White	106-1930-0375-201	106-1830-0375-201	106-0375-200
Yellow	106-1930-0376-201	106-1830-0376-201	106-0376-200
Base Assembly	8-1930-01-201	8-1830-01-201	—

LIGHT SHIELD INDICATOR LIGHTS

MOUNT FROM FRONT OF PANEL IN 15/32" CLEARANCE HOLE

An opening in the side of the metal lamp holder emits light on the panel to illuminate dials or controls. The usual opening is 1/4" X 5/32". Other openings are available on request. These units may be supplied with molded colored filter to provide red light (or other color). The light shield unscrews for easy lamp replacement from the front of panel.

FINISHES: No optional finishes are offered on "113-" series. To designate "4-" series with optional finish, see description on Page 3.

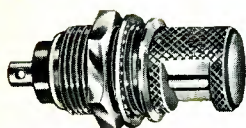

4-1930-2900-201

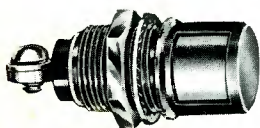

113-1830-2931-201

FOR MOUNTING IN 15/32" CLEARANCE HOLE

TERMINAL TYPE	COMPLETE ASSEMBLY WITH NO FILTER		COMPLETE ASSEMBLY WITH MOLDED FILTER	
	NO FILTER	MOLDED FILTER	NO FILTER	MOLDED FILTER
Soldering	4-1930-2900-201	113-1930-2931-201	4-2900-200	113-2931-200
Base Assembly	4-1930-29-201	4-1930-29-201	—	—
Screw	4-1830-2900-201	113-1830-2931-201	4-2900-200	113-2931-200
Base Assembly	4-1830-29-201	4-1830-29-201	—	—

FILTER COLORS: The digit before the three digit catalog number suffix indicates that the filter is RED. When a color other than red is desired, change this digit to a figure from the listing below:
Red—1; Green—2; Yellow (Amber)—3; Blue—4; Clear (Colorless)—7.

Example: 113-1930-2934-201 (Blue)

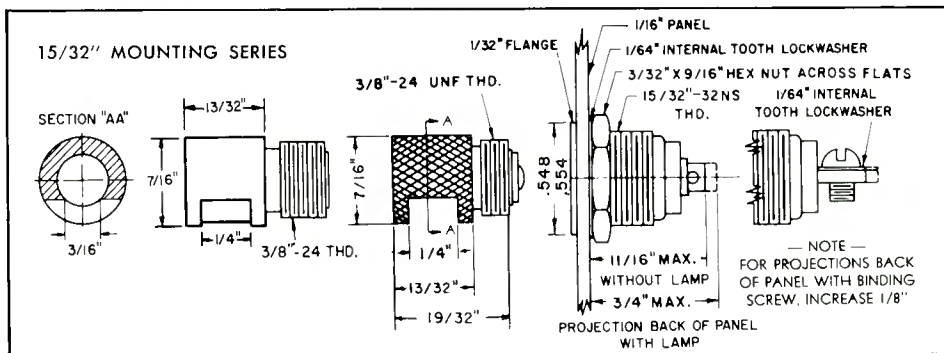

SUB-MINIATURE LAMP HOLDER

Single Terminal, Grounded

Mount in 13/32" Clearance Hole

The lamp is removable only from REAR of panel.

STANDARD FINISH: White nickel. No options available.

Catalog No. 259-1930-2900-101



WATERPROOF CONSTRUCTION

Many of the indicator lights shown may be supplied with resilient gaskets which make them waterproof on the front of the panel. Information will be supplied on request.



DIALIGHT

Sub-Miniature Indicator Lights for translucent panel edge lighting

For use with MIL-P-7788 (plastic plate) panels • Meet all applicable requirements of Military Specification MIL-L-7806 • Shadowless lighting (no blind spots) • All filters conform to MS25010. Meet requirements of MIL-L-3661B.

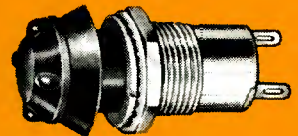



SUB-MINIATURE INDICATOR LIGHTS

for TRANSLUCENT PANEL EDGE LIGHTING

FOR USE WITH MIL-P-7788 (PLASTIC PLATE) PANELS

T-134 bulb with midget flange base.



These indicator lights are designed to emit light through a colored filter radially into the plastic plate. A resilient light seal washer (light trap) insures against light loss at the front of the panel.

When it is necessary to insulate the mounting bushing of the one-terminal grounded lights from the metal panel, 2 insulating washers and 1 grounding terminal may be provided. See Insulated Mounting on Page 5.

Dialight Corporation reserves the right to make changes at anytime in order to improve design and to supply the best product possible.

**SAMPLES ON REQUEST AT ONCE
- NO CHARGE**

- Ratings of lamps are taken from published catalogs of leading lamp manufacturers. Rated life is generally recognized as the 50% failure point of a group of lamps tested under static laboratory conditions, with the voltage closely regulated at the design value. This may not necessarily agree with the service of a lamp where the effects of temperature, vibration and voltage fluctuations may result in a shorter than rated life.

MANUFACTURER'S RATINGS

(Values given are approx.)

LAMP NO.	VOLTS	AMPERES	HOURS	CANDLE POWER
331	1.35	.06	5,000	.006
338	2.7	.06	6,000	.04
375	3.0	.015	20,000	.004
7332	5.0	.06	30,000	.05
*328	6.0	.20	1,000	.63
345	6.0	.04	10,000	.03
349	6.3	.20	5,000	.55
380	6.3	.04	20,000	.02
381	6.3	.20	20,000	.40
344	10.0	.014	25,000	.002
367	10.0	.04	10,000	.08
330	14.0	.08	1,500	.50
382	14.0	.08	15,000	.30
*370	18.0	.04	10,000	.15
**327	28.0	.04	4,000	.34
**387	28.0	.04	7,000	.30

*Conforms to MS25237

**MS18209 (BuShips)

Illus. are approx. actual size.

TWO TERMINALS — FULLY INSULATED

MOUNT FROM FRONT OF PANEL
IN 15/32" CLEARANCE HOLE

MS25010—REVISION D
MIL-L-3661B

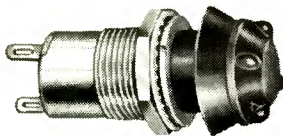

271-8430-0111-702
MS25010C11B
LH92/1; LC34EN2/D02

Meet all applicable requirements of MIL-L-7806, MIL-L-3661B & MS25010—REVISION D

CATALOG NO. ■	MIL-L-3661B	*MILITARY STANDARD DWG. NO. ■	FILTER COLOR	TOP COLOR	LIGHT SEAL WASHER— OPAQUE	HOLDER (FILTER CAP) ASSEMBLY	HOLDER (FILTER CAP) ASSEMBLY MIL-L-3661B
271-8430-0111-702	LH92/1; LC34EN2/D02	MS25010C11B	Red	Black	Black	271-0111	LC34EN2/D02
271-8430-0171-702	LH92/1; LC34CN2/D02	MS25010C12B	Clear	Black	Black	271-0171	LC34CN2/D02
271-8430-3111-702	LH92/1; LC34EN2/EN2	MS25010C13B	Red	Red	Black	271-3111	LC34EN2/EN2
271-8430-3171-702	_____	MS25010C14B	Clear	Red	Black	271-3171	_____
271-8430-0212-702	LH92/1; LC34EN2/S02	MS25010C15B	Red	Gray	Gray	271-0212	LC34EN2/S02
271-8430-0272-702	LH92/1; LC34CN2/S02	MS25010C16B	Clear	Gray	Gray	271-0272	LC34CN2/S02

Mounting Base: 271-8430-702 (MS25010C); (LH92/1 per MIL-L-3661B).

*To designate an assembly by MS number complete with MS25237-327 or MS25237-328 lamp requires the call out and addition of the lamp number to the MS number suffix. Examples: MS25010C12B327; MS25010C16B328. There is no MS designation of assembly complete with other lamps listed.

There are no Dialight catalog numbers for assemblies complete with lamp. To order, call out correct lamp designation with desired assembly. By so doing, you will assure receipt of the desired indicator light and lamp at one time, ready for immediate use.

Examples: 271-8430-3111-702 with #382 lamp; 271-8430-0222-702 with #387 lamp.

- The complete assembly will be marked with MS and LH part numbers for Mounting Base only.

MATERIALS AND FINISHES

- **Mounting Bushing:** Brass, cadmium plated with yellow iridescent chromate finish.
- **Hardware:** Internal-tooth lockwasher and hex mounting nut—Steel, cadmium plated with yellow iridescent chromate finish.
- **Terminals:** Brass, hot-tinned, with elongated slots.

Anti-Rotation Notch on face of flange prevents rotation of unit while nut is being tightened.

Note: On all units, the shank of the lens holder is crimped in 3 evenly spaced places to secure the lamp.

NEW CATALOG NO.	OLD CATALOG NO.	FILTER COLOR	TOP COLOR	LIGHT SEAL WASHER— OPAQUE	HOLDER (FILTER CAP) ASSEMBLY
271-8430-0121-702	TT78-8430-B2	Green	Black	Black	271-0121
271-8430-0131-702	TT78-8430-B3	Amber	Black	Black	271-0131
271-8430-0222-702	TT85-8430-GR2	Green	Gray	Gray	271-0222
271-8430-0232-702	TT85-8430-GR3	Amber	Gray	Gray	271-0232

Mounting Base: 271-8430-702

HOLDER (FILTER CAP)

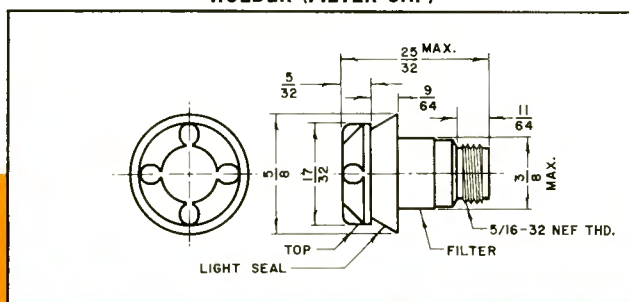

MOUNTING BASE

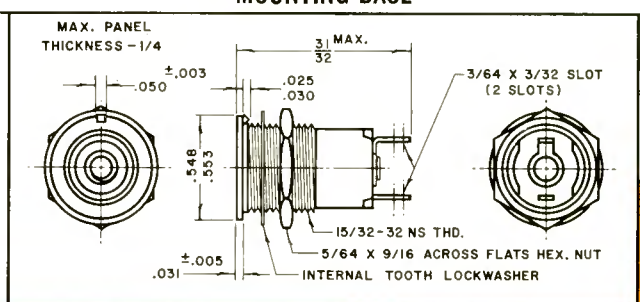

SUB-MINIATURE INDICATOR LIGHTS

for TRANSLUCENT PANEL EDGE LIGHTING

FOR USE WITH MIL-P-7788 (PLASTIC PLATE) PANELS



Illus. are approx. actual size.

MOUNT FROM FRONT OF PANEL in 15/32" CLEARANCE HOLE

MS25010 — REVISION D

ONE TERMINAL

MATERIALS AND FINISHES

- **Mounting Bushing:** Brass, cadmium plated with yellow iridescent chromate finish.
- **Hardware:** Internal-tooth lockwasher and hex mounting nut—Steel, cadmium plated with yellow iridescent chromate finish.
- **Terminals: Soldering—**Brass, hot tin dip.
Screw—Brass, cadmium plated with yellow iridescent chromate finish.

Note: On all units, the shank of the lens holder is crimped in 3 evenly spaced places to secure the lamp.



270-1930-0111-702
SOLDERING TERMINAL



270-1830-0111-702
SCREW TERMINAL

NEW CAT. NO. WITH OPAQUE BLACK TOP AND LIGHT SEAL ■	OLD CATALOG NUMBER	*MILITARY STANDARD DWG. NO. ■	NEW CAT. NO. WITH OPAQUE GRAY TOP AND LIGHT SEAL ■	OLD CATALOG NUMBER	*MILITARY STANDARD DWG. NO. ■	FILTER COLOR	TERMINAL TYPE	HOLDER (FILTER CAP ASSEMBLY)	
								BLACK TOP	GRAY TOP
270-1930-0111-702	TT61	MS25010A11A	270-1930-0212-702	TT67	MS25010A15A	Red	Soldering	270-0111	270-0212
270-1830-0111-702	TT62	MS25010B11A	270-1830-0212-702	TT68	MS25010B15A	Red	Screw	270-0111	270-0212
270-1930-0171-702	TT61-B7	MS25010A12A	270-1930-0272-702	TT67-GR7	MS25010A16A	Clear	Soldering	270-0171	270-0272
270-1830-0171-702	TT62-B7	MS25010B12A	270-1830-0272-702	TT68-GR7	MS25010B16A	Clear	Screw	270-0171	270-0272

Mounting Base: 270-1930-702 (with Soldering Terminal); 270-1830-702 (with Screw Terminal).

*To designate an assembly by MS number complete with MS25237-327 or MS25237-328 lamp requires the call out and addition of the lamp number to the MS number suffix. Examples: MS25010A12A327; MS25010B16A328. There is no MS designation of assembly complete with other lamps listed.

There are no Dialight catalog numbers for assemblies complete with lamp. To order, call out correct lamp designation with desired assembly. By so doing, you will assure receipt of the desired indicator light and lamp at one time, ready for immediate use.

Examples: 270-1930-0171-702 with #381 lamp; 270-1830-0141-702 with #387 lamp.

■ The complete assembly will be marked with MS part number for Mounting Base only.

NEW CAT. NO. WITH OPAQUE BLACK TOP AND LIGHT SEAL	OLD CATALOG NUMBER	NEW CAT. NO. WITH OPAQUE GRAY TOP AND LIGHT SEAL	OLD CATALOG NUMBER	FILTER COLOR	TERMINAL TYPE	HOLDER (FILTER CAP ASSEMBLY)	
						BLACK TOP	GRAY TOP
270-1930-0121-702	TT61-B2	270-1930-0222-702	TT67-GR2	Green	Soldering	270-0121	270-0222
270-1830-0121-702	TT62-B2	270-1830-0222-702	TT68-GR2	Green	Screw	270-0121	270-0222
270-1930-0131-702	TT61-B3	270-1930-0232-702	TT67-GR3	Amber	Soldering	270-0131	270-0232
270-1830-0131-702	TT62-B3	270-1830-0232-702	TT68-GR3	Amber	Screw	270-0131	270-0232
270-1930-0141-702	TT61-B4	270-1930-0242-702	TT67-GR4	Blue	Soldering	270-0141	270-0242
270-1830-0141-702	TT62-B4	270-1830-0242-702	TT68-GR4	Blue	Screw	270-0141	270-0242

Mounting Base: 270-1930-702 (with Soldering Terminal); 270-1830-702 (with Screw Terminal).

Insulated Mounting: See description and catalog number designations on Page 5.

HOLDER (FILTER CAP)

MOUNTING BASES

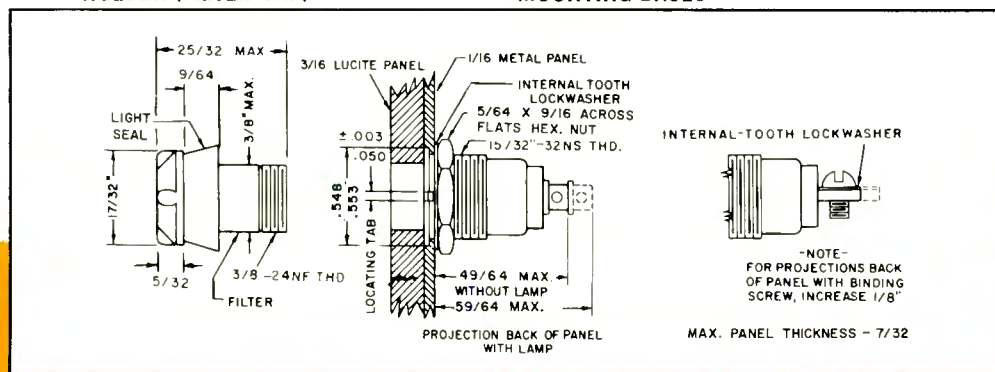



SUB-MINIATURE INDICATOR LIGHTS

WITH LIGHT EMITTING OR INSET LENS TOP

FOR TRANSLUCENT PANEL EDGE LIGHTING

DESIGN ELIMINATES BLIND SPOTS—PRODUCES SHADOW-LESS LIGHTING

Illus. are approx. actual size.

INDICATOR LIGHTS WITH LIGHT EMITTING TOP

MOUNT FROM FRONT OF PANEL
IN 15/32" CLEARANCE HOLE

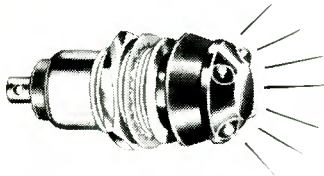

270-1930-3111-702

NEW CATALOG NUMBER ■	OLD CATALOG NUMBER	*MILITARY STANDARD DWG. NO. ■	FILTER COLOR	TOP COLOR	LIGHT SEAL WASHER—OPAQUE	TERMINAL TYPE	HOLDER (FILTER CAP) ASSEMBLY
270-1930-3111-702	TT61-R1	MS25010A13A	Red	Red	Black	Soldering	270-3111
270-1830-3111-702	TT62-R1	MS25010B13A	Red	Red	Black	Screw	270-3111
270-1930-3171-702	TT61-R7	MS25010A14A	Clear	Red	Black	Soldering	270-3171
270-1830-3171-702	TT62-R7	MS25010B14A	Clear	Red	Black	Screw	270-3171

Mounting Base: 270-1930-702 (MS25010A) with Soldering Terminal; 270-1830-702 (MS25010B) with Screw Terminal.

*To designate an assembly by MS number complete with MS25237-327 or MS25237-328 lamp requires the call out and addition of the lamp number to the MS number suffix.

Examples: MS25010A13A327; MS25010B14A328. There is no MS designation of assembly complete with other lamps listed.

■ The complete assembly will be marked with MS part number for Mounting Base only.

All of the units listed at the right are available with transparent tops in the various colors, or with back matting for diffusion. Specify the latter by changing the "3" in that part of the catalog number that reads -3111- to "4".

Examples: 270-1830-4111-702; 270-4771 (filter cap only).

NEW CATALOG NUMBER	OLD CATALOG NUMBER	FILTER COLOR	TOP COLOR	LIGHT SEAL WASHER—OPAQUE	TERMINAL TYPE	HOLDER (FILTER CAP) ASSEMBLY
270-1930-3221-702	TT61-G2	Green	Green	Black	Soldering	270-3221
270-1830-3221-702	TT62-G2	Green	Green	Black	Screw	270-3221
270-1930-3331-702	TT61-A3	Amber	Amber	Black	Soldering	270-3331
270-1830-3331-702	TT62-A3	Amber	Amber	Black	Screw	270-3331
270-1930-3771-702	TT61-C7	Clear	Clear	Black	Soldering	270-3771
270-1830-3771-702	TT62-C7	Clear	Clear	Black	Screw	270-3771

Mounting Base: 270-1930-702 (with Soldering Terminal); 270-1830-702 (with Screw Terminal).

MATERIALS AND FINISHES:

See description on Page 3.

SAMPLES ON REQUEST — AT ONCE — NO CHARGE

Insulated Mounting: See description and catalog number designations on facing page.



274-1930-7111-702

These assemblies provide wide angle of visibility with inset colored lens in an opaque top.

HOLDERS (FILTER CAPS)

MOUNTING BASES

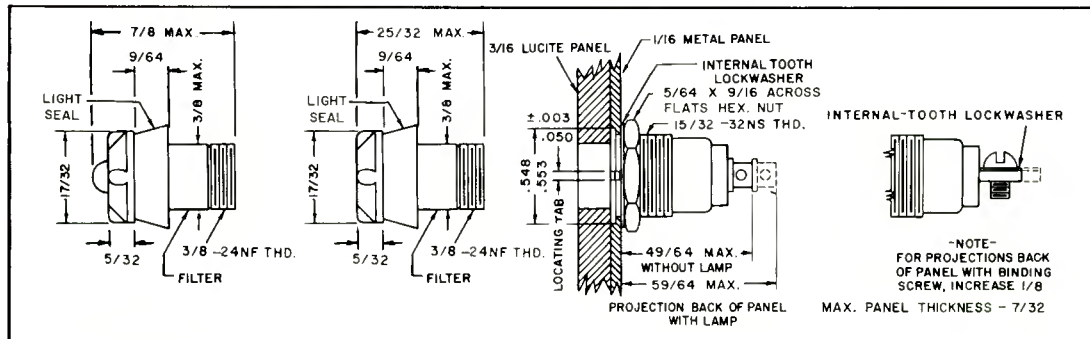

INDICATOR LIGHTS WITH INSET LENS TOP

MOUNT FROM FRONT OF PANEL IN 15/32" CLEARANCE HOLE

NEW CATALOG NUMBER	OLD CATALOG NUMBER	FILTER COLOR	*INSET LENS COLOR	TOP COLOR	LIGHT SEAL WASHER—OPAQUE	TERMINAL TYPE	HOLDER (FILTER CAP) ASSEMBLY
274-1930-7111-702	TT63-R1	Red	Red	Black Opaque	Black	Soldering	274-7111
274-1830-7111-702	TT66-R1	Red	Red	Black Opaque	Black	Screw	274-7111
274-1930-7101-702	TT63-R0	Opaque	Red	Black Opaque	Black	Soldering	274-7101
274-1830-7101-702	TT66-R0	Opaque	Red	Black Opaque	Black	Screw	274-7101
274-1930-7201-702	TT63-G0	Opaque	Green	Black Opaque	Black	Soldering	274-7201
274-1830-7201-702	TT66-G0	Opaque	Green	Black Opaque	Black	Screw	274-7201
274-1930-7301-702	TT63-A0	Opaque	Amber	Black Opaque	Black	Soldering	274-7301
274-1830-7301-702	TT66-A0	Opaque	Amber	Black Opaque	Black	Screw	274-7301

Mounting Base: 270-1930-702 (with Soldering Terminal); 270-1830-702 (with Screw Terminal).

*The above catalog numbers and designations for "Holder (Filter Cap Assembly)" indicate Translucent inset lens. If a Transparent inset lens is required, change the "7" in that part of the catalog number that reads -7111- to "3".

Examples: 274-1830-3201-702 (complete assembly); 274-3201 (Filter Cap Assembly).

INDICATOR LIGHTS FOR PLASTIC PANELS

Extended neck passes through MIL-P-7788 panel



Illus. are approx. actual size.

NON-DIMMING

These indicator lights are especially intended for mounting on the metal backing plate with long neck to extend through the plastic panel.

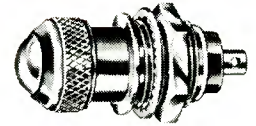

8-3730-0131-201

LENS SURFACE	CAT. NO. WITH SOLDERING TERMINAL	CAT. NO. WITH BINDING SCREW TERMINAL	LENS CAP ASSEMBLY
Unfrosted	8-3730-0131-201	8-4930-0131-201	8-0131-200
Back Frosted	8-3730-0111-201	8-4930-0111-201	8-0111-200
Base Assembly	8-3730-01-201	8-4930-01-201	—

MATERIALS AND FINISHES

- **Mounting Bushing:** Brass, black nickel finish.
- **Mounting Nut:** Brass, white nickel finish.
- **Internal-tooth Lockwasher:** Phosphor bronze, white nickel finish.
- **Terminal: Soldering—**Brass, hot tin dip.

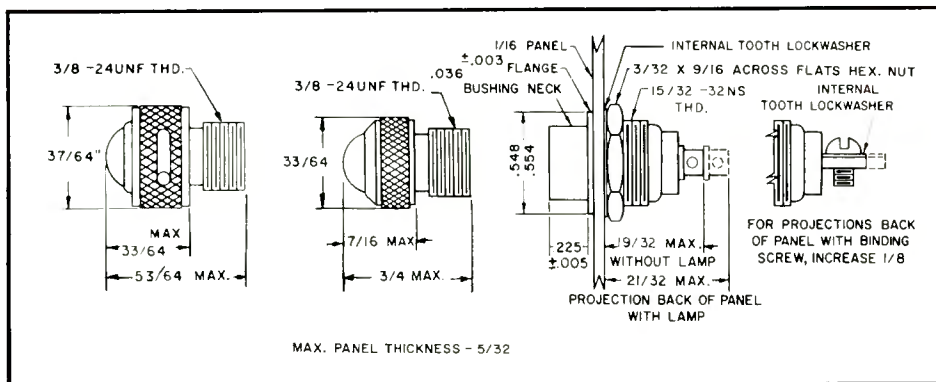

LENS COLOR: The digit before the last dash in the catalog number designates RED color. When color other than red is desired, change this digit to a figure shown below.

Note that white lenses are translucent and are always furnished unfrosted.

Red - 1; Green - 2; Yellow (Amber) - 3; Blue - 4; White Translucent - 5; Light Yellow - 6; Clear (colorless) - 7.
Example: 2-3730-0112-201 (Green).

Order complete with lamp; specify lamp number.

DIMMING

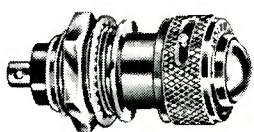

11-3730-0131-201

The dimmer lights are provided with a knurled section of the cap which may be rotated on the fixed portion to adjust the light intensity. The mechanical type indicator light may be completely blacked out or may have a small permanent opening to insure some visibility under all conditions. Polaroid type indicator light gives full diameter light pattern.

Materials and Finishes: See description above.

DIMMER TYPE	LENS SURFACE	CAT. NO. WITH SOLDERING TERMINAL	CAT. NO. WITH BINDING SCREW TERMINAL	LENS CAP ASSEMBLY
Complete Blackout	Unfrosted	11-3730-0131-201	11-4930-0131-201	11-0131-200
	Back Frosted	11-3730-0111-201	11-4930-0111-201	11-0111-200
Semi-Blackout	Unfrosted	2-3730-0131-201	2-4930-0131-201	2-0131-200
	Back Frosted	2-3730-0111-201	2-4930-0111-201	2-0111-200
Polaroid	Unfrosted	3-3730-0131-201	3-4930-0131-201	3-0131-200
	Back Frosted	3-3730-0111-201	3-4930-0111-201	3-0111-200
Base Assembly	—	8-3730-01-201	8-4930-01-201	—

INSULATED MOUNTING

The one terminal sub-miniature indicator lights listed in this catalog may be provided with insulating washers and terminal when it is required that the grounded bushing shall not be connected to the metal panel. As shown in the diagram, extra threads are provided for this purpose.

Use the Catalog Number Suffix "-707" to cover this feature for use on all one terminal Panel Edge Lighting assemblies. Example: 270-1930-0131-707. The former coding "-XP15" in the catalog number, which designated Insulated Mounting, has been superseded by the catalog number suffix "-707".

This feature also applies to all of the assemblies listed on this page... and is so designated by the catalog number suffix "-207." Example: 11-3730-0111-207.

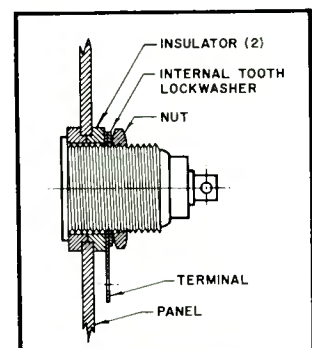



SUB-MINIATURE INDICATOR LIGHTS FOR TRANSLUCENT PANEL EDGE LIGHTING

TWO TERMINALS — FULLY INSULATED

Illus. are approx. actual size.

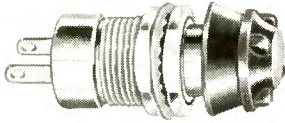

272-3830-0111-101
Mounts from rear of panel
in 15/32" clearance hole

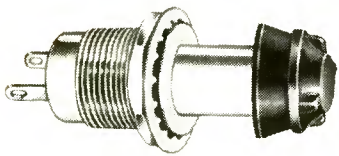

273-5030-0111-101
Mounts from front of panel
in 17/32" clearance hole

SAMPLES ON REQUEST —
AT ONCE — NO CHARGE

All two terminal assemblies listed on this and the facing page are available with the same selection of colored tops and filters as are listed for one terminal assemblies.

MATERIALS AND FINISHES

- **Mounting Bushing:** Brass, white nickel finish.
- **Hardware: (Back Mtg. assemblies)**—Mounting and Flange Nuts: Brass, white nickel finish. **(Front Mtg. assemblies)**—Mounting Nut and Fixed Flange: Brass, white nickel finish. Internal-tooth Lockwasher: Phosphor bronze, white nickel finish.
- **Terminals:** Brass, hot-tinned with elongated slot.
Note: On all assemblies, the shank of the lens holder is crimped in 3 evenly spaced places to secure the lamp.

See chart for catalog numbers on facing page.

Order complete with lamp; specify lamp number.

MOUNTING BASES

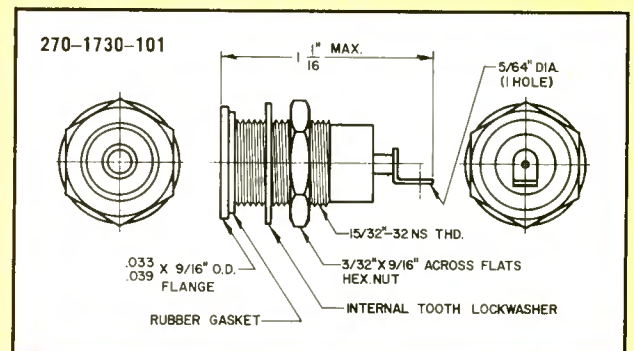
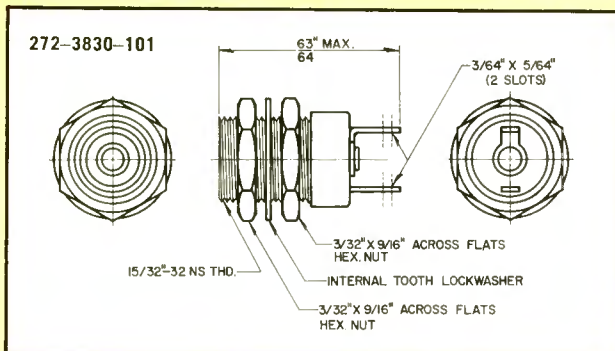
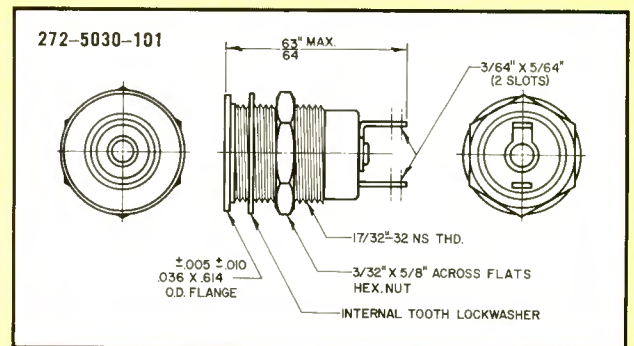
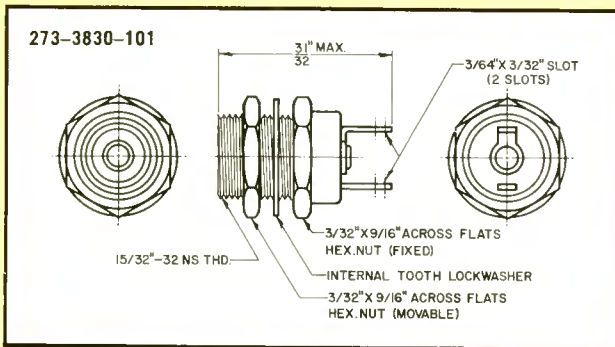

DIALIGHT

A NORTH AMERICAN PHILIPS COMPANY

203 HARRISON PLACE • BROOKLYN, N.Y. 11237 • 212 497-7600 • TWX: 710-584-5487

SUB-MINIATURE INDICATOR LIGHTS FOR TRANSLUCENT PANEL EDGE LIGHTING

TWO TERMINALS — FULLY INSULATED



Illus. are approx. actual size.

The catalog numbers listed in the chart below describe indicator lights shown on this and the facing page.

See Materials and Finishes on the facing page.

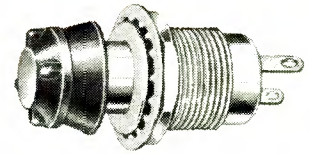

272-5030-0111-101
Mounts from front of panel
in 17/32" clearance hole

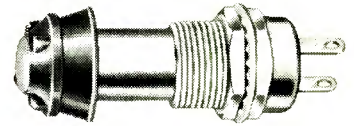

273-3830-0111-101
Mounts from rear of panel
in 15/32" clearance hole

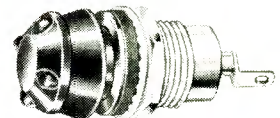

270-1730-0111-101
1 terminal, grounded, with hermetic
seal. Mounts from front of panel
in 15/32" clearance hole

NEW CATALOG NUMBER	OLD CATALOG NUMBER	FILTER COLOR	TOP COLOR	LIGHT SEAL WASHER— OPAQUE	PANEL MTG.	MOUNTING BASE	HOLDER (FILTER CAP) ASSEMBLY
273-3830-0111-101 ■	TT54-3830	Red	Black	Black	Rear	273-3830-101	273-0111
273-5030-0111-101 ■	TT54-5030	Red	Black	Black	Front	272-5030-101	273-0111
272-3830-0111-101 ■	TT55-3830	Red	Black	Black	Rear	272-3830-101	272-0111
272-3830-0121-101	TT55-3830-B2	Green	Black	Black	Rear	272-3830-101	272-0121
272-3830-0131-101	TT55-3830-B3	Amber	Black	Black	Rear	272-3830-101	272-0131
272-3830-0171-101	TT55-3830-B7	Clear	Black	Black	Rear	272-3830-101	272-0171
272-5030-0111-101 ■	TT55-5030	Red	Black	Black	Front	272-5030-101	272-0111
272-5030-0121-101	TT55-5030-B2	Green	Black	Black	Front	272-5030-101	272-0121
272-5030-0131-101	TT55-5030-B3	Amber	Black	Black	Front	272-5030-101	272-0131
272-5030-0171-101	TT55-5030-B7	Clear	Black	Black	Front	272-5030-101	272-0171
270-1730-0111-101 ■	TT59	Red	Black	Black	Front	270-1730-101	270-0111

■ Available in a full range of filter colors as well as gray opaque tops.

NOTE: These assemblies are also available with light emitting tops and inset lens tops.

HOLDERS (FILTER CAP ASSEMBLIES)

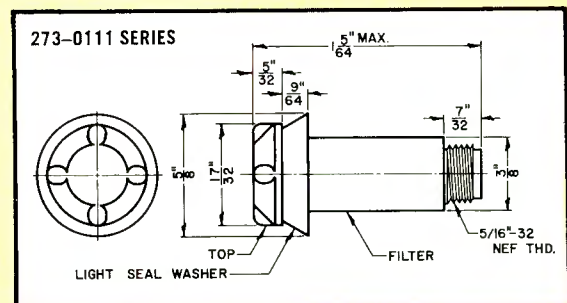
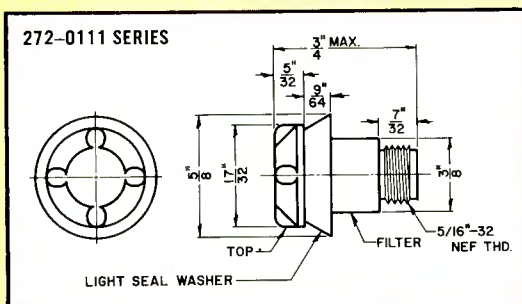
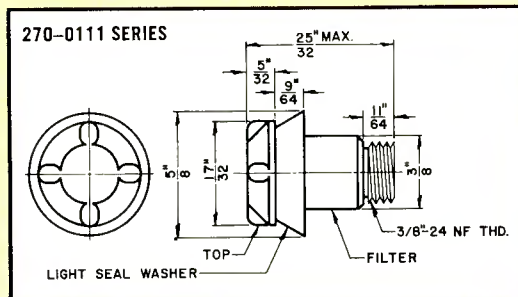

DIALIGHT

203 Harrison Place, Brooklyn, N.Y. 11237
Phone: (212) 497-7600

CURRENT DIALCO LITERATURE

Indicator Lights

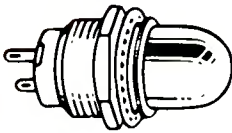

- ▲ Sub-Sub-Miniature Indicator Lights L-168
- ▲ Sub-Miniature Indicator Lights
 - ▲ One Terminal (For Grounded Circuits) L-157
 - ▲ Edge Lighting for Plastic Plates L-158
 - ▲ Two Terminals, Fully Insulated L-178
- ▲ Ultra-Miniature Indicator Lights UM-1200
- ▲ Miniature & Large Indicator Lights L-161
- ▲ Twin Lamp Placard Lights L-170
- ▲ Heavy Duty Oil-Tight Indicator Lights L-200
- ▲ Press-to-Test Indicator Lights L-201
- ▲ Flashing Indicator Light L-211
- ▲ A Cross Reference of DIALIGHT Catalog numbers to Military Type Designations and MS Drawings CR-680
- ▲ Indicator Light Selector Guide SG730

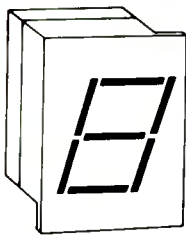

Readouts

- ▲ Readout Product Selector Guide SG732

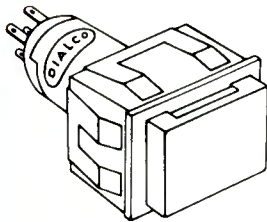

Switches

- ▲ Illuminated Push Button Switches and matching indicators L-210
- ▲ Solid State Switch SW6110
- ▲ Thumbwheel Switches SW6120

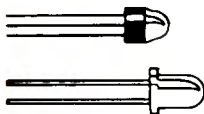

LED Displays

- ▲ LED Product Selector Guide
 - ▲ LEDs, Indicators, Readouts SG731

Send for your copies of these catalogs



DIALIGHT

CORPORATION

sub-miniature Indicator Lights
two terminal-fully insulated



A NORTH AMERICAN PHILIPS COMPANY

(All illustrations are approx. actual size)

INCANDESCENT INDICATOR LIGHTS

TWO TERMINALS—FULLY INSULATED

MEET OR EXCEED ENVIRONMENTAL AND OPERATIONAL REQUIREMENTS
OF MIL-L-6723 AND MIL-L-3661B

FEATURES:

- Available for mounting from FRONT or BACK of panel in 15/32" or 17/32" clearance hole; also from FRONT of panel in 15/32" or 17/32" clearance hole.
- Rugged-phenolic insulated: The socket, lamp, and all connections are well insulated from the mounting bushing by means of phenolic material of military specification grade.
- Lens cap assembly unscrews from front of panel for easy replacement of the lamp. Indicators on Pages 6-7 have friction-fit lens caps—and too—are easily removed from front of panel.
- Two terminals (soldering) are provided for electrical connections.
- Anti-rotation (locked) construction: Provides for secure locking of the socket terminal assembly in the mounting bushing and of the center terminal to the insulating disc. The notched mounting bushing receives the matched insulating disc—prevents rotation of the mounting bushing.
- Order complete with lamp. Specify lamp number.

HOW TO DESIGNATE THE THREE DIGIT CATALOG NUMBER SUFFIX (-XXX)

FINISH	RESISTOR	HARDWARE
-1 white nickel	0—none	0—none
-2 black nickel		1—brass
-3 polished chrome		2—steel
-5 black anodize		3—water-tight on the face of the panel
-6 clear anodize		4—aluminum

NOTE: The part numbers given in this catalog indicate **standard** indicator lights. The table at the left provides the standard and optional designations for **Finish** and **Hardware** (for Incandescent Assemblies only) where appropriate. Example: 101-8430-0931-101 (white nickel finish).

LIGHT SOURCE

All sub-miniature indicator lights described on Pages 2-8 are intended to be used with T-1 3/4 bulbs, with midget flanged base, incandescent.



MANUFACTURER'S RATINGS

(Values given are approx.)

LAMP NO.	VOLTS	AMPERES	HOURS	CANDLE POWER
▲ 331	1.35	.06	500	.006
▲ 338	2.7	.06	500	.04
▲ 375	3.0	.015	20,000	.004
7332	5.0	.06	30,000	.05
* 328	6.0	.20	1,000	.63
345	6.0	.04	1,000	.03
349	6.3	.20	3,000	.55
380	6.3	.04	50,000	.02
381	6.3	.20	50,000	.40
▲ 344	10.0	.014	50,000	.002
367x	10.0	.04	5,000	.08
330	14.0	.08	750	.50
382	14.0	.08	50,000	.30
370	18.0	.04	1,000	.15
* 327	28.0	.04	4,000	.34
** 387	28.0	.04	7,000	.30

▲ These lamps **only** are for use with transparent lens caps **without** legends.

*Conforms to MS25237.

**MS18209 (BuShips)

MOUNT IN 15/32" CLEARANCE HOLE
FRONT OR BACK OF PANEL INSERTION
WITH MOVABLE FLANGE

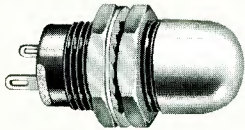

101-3830-0931-201

MOUNT IN 17/32" CLEARANCE HOLE
FRONT OF PANEL INSERTION
WITH FIXED FLANGE

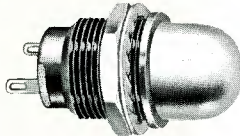

101-5030-0931-201

MOUNT IN 15/32" CLEARANCE HOLE
FRONT OF PANEL INSERTION
WITH FIXED FLANGE

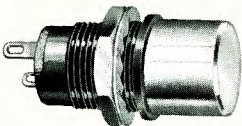

140-8430-1471-201

OMNIDIRECTIONAL LENS

Omnidirectional Lenses in Signal Colors . . . These unique stovepipe and flat cylindrical lenses are molded of high heat plastic. They radiate light in all directions. The heavy wall of the lens is reinforced by a threaded brass insert. This fitting receives the lamp and screws into the internal thread of the bushing. The bulb enters well into the plastic lens for best effectiveness.

Whether used on the **front** or **back** insertion assembly, the lens cap is readily removable from the front of the panel, thus making the lamp accessible for easy replacement, without the use of tools.

MATERIALS AND FINISHES

- **Mounting Bushing:** Brass, black nickel finish. Optional — White nickel or chrome finish.
- **Mounting Nut:** Front or Back Mtg. (movable flange) — Brass, black nickel finish. Front Mtg. (fixed flange) — Brass, white nickel finish.
- **Flange Nut:** (movable) — Brass, black nickel finish. Optional — White nickel or chrome finish.
- **Internal-tooth Lockwasher:** Phosphor bronze, white nickel finish.
- **Terminals:** Brass, hot tinned, with elongated slot.

TYPE MOUNTING	LENS SURFACE	CATALOG NUMBER STOVEPIPE LENS SHAPE	CATALOG NUMBER CYLINDRICAL LENS SHAPE	BASE ASSEMBLY	LENS CAP ASSEMBLIES	
					STOV'P	CYL.
Front or Back Mtg. in 15/32" Clearance Hole	Transparent	101-3830-0931-201	140-3830-1431-201	101-3830-09-201	101-0931	140-1431
	Translucent	101-3830-0971-201	140-3830-1471-201		101-0971	140-1471
Front Mtg. in 17/32" Clearance Hole	Transparent	101-5030-0931-201	140-5030-1431-201	101-5030-09-201	101-0931	140-1431
	Translucent	101-5030-0971-201	140-5030-1471-201		101-0971	140-1471
Front Mtg. in 15/32" Clearance Hole	Transparent	101-8430-0931-201	140-8430-1431-201	101-8430-09-201	101-0931	140-1431
	Translucent	101-8430-0971-201	140-8430-1471-201		101-0971	140-1471

LENS COLOR: See description on facing page.

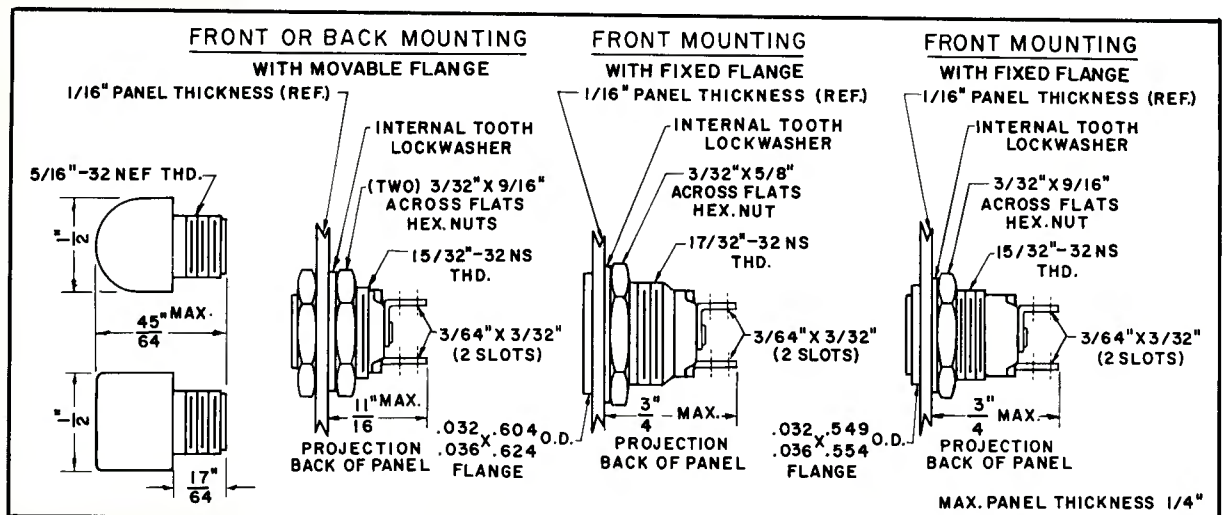

SAMPLES ON REQUEST
AT ONCE—NO CHARGE

OMNIDIRECTIONAL LENS



CATALOG NUMBER	MS. NO. WITHOUT LAMP*	LENS CAP COLOR	LENS CAP ASSEMBLIES
162-8430-0933-502	MS25256-2	Aviation Yellow	162-0933
162-8430-0932-502	MS25256-4	Aviation Green	162-0932
162-8430-0931-502	MS25256-6	Identification Red	162-0931
162-8430-0937-502	MS25256-8	Aviation White	162-0937
162-8430-0975-502	MS25256-10	Translucent White	162-0975
162-8430-0934-502	MS25256-12	Aviation Blue	162-0934

*Marking: Part number marked on the assembly is the part number for the complete assembly less lamp.

LENS CAP SHAPE	CATALOG NO. WITH TRANSLUCENT LENS	CATALOG NO. WITH TRANSPARENT LENS	LENS CAP ASSEMBLIES TRANSPARENT
Stovepipe	162-8430-0971-502	MS-See table above	162-0971
Cylindrical	162-8430-1471-502	162-8430-1431-502	162-1471 162-1431
Base Assembly	162-8430-09-502	162-8430-09-502	

The above noted assemblies are not covered by MS designations. For standard DIALCO colors, see Lens Color Code below.

MIL-L-3661B

LENS CAP COLOR	STOVEPIPE LENS CAP*				CYLINDRICAL LENS CAP*			
	NON-DIFFUSING		TRANSLUCENT		NON-DIFFUSING		TRANSLUCENT	
	TYPE DESIG.	CATALOG NUMBER	TYPE DESIG.	CATALOG NUMBER	TYPE DESIG.	CATALOG NUMBER	TYPE DESIG.	CATALOG NUMBER
Red	LC12RN2	162-0931	LC12RT2	162-0971	LC29RN2	162-1431	LC29RT2	162-1471
Green	LC12GN2	162-0932	LC12GT2	162-0972	LC29GN2	162-1432	LC29GT2	162-1472
Yellow (Amber)	LC12YN2	162-0933	LC12YT2	162-0973	LC29YN2	162-1433	LC29YT2	162-1473
Blue	LC12BN2	162-0934	LC12BT2	162-0974	LC29BN2	162-1434	LC29BT2	162-1474
White			LC12WT2	162-0975			LC29WT2	162-1475
Clear (Colorless)	LC12CN2	162-0937			LC29CN2	162-1437		
Base (LH73/1)					359-8430-09-502			
Assemblies (LH73/2)+					362-8430-09-702			

*These lens caps are also available with RFI feature. They are to be used with LH73/2 base assembly only. For stovepipe lens cap, change 12 in Type Designation to 27. For cylindrical lens cap, change 29 to 26. It is also necessary to change the Catalog Number prefix from 162- to 235-. Examples: LC27YN2 235-0933; LC26BT2 235-1474.

+ For use with LC25, LC26 and LC27 lens caps only.

ROTATABLE LENS

Specially designed spring mounting facilitates rotation of lens and alignment of legend — after installation of the Indicator Light.

LENS SHAPE	LENS FINISH	CATALOG NUMBER	LENS CAP ASSEMBLIES
FLAT	Transparent	178-8430-0331-502	178-0331-500
	Translucent	178-8430-0371-502	178-0371-500
CONVEX	Unfrosted	178-8430-0131-502	178-0131-500
	Back Frosted	178-8430-0111-502	178-0111-500
FACETED	Unfrosted	178-8430-2131-502	178-2131-500
Base Assembly		162-8430-09-502	

■ Specify translucent colors as follows: Red—0371; Green—0372; Yellow (Amber)—0373; Blue—0374; White—0375; Light Yellow—0376

MIL-L-3661B

LENS CAP COLOR	FLAT LENS CAP**					
	NON-DIFFUSING			TRANSLUCENT+		
	TYPE DESIG.	CATALOG NUMBER	TYPE DESIG.	CATALOG NUMBER	TYPE DESIG.	CATALOG NUMBER
Red	LC11RN2	178-0331-500	LC11RT2	178-0371-500	LC11RB2	178-5771-500
Green	LC11GN2	178-0332-500	LC11GT2	178-0372-500	LC11GB2	178-5772-500
Yellow (Amber)	LC11YN2	178-0333-500	LC11YT2	178-0373-500	LC11YB2	178-5773-500
Blue	LC11BN2	178-0334-500	LC11BT2	178-0374-500	LC11BB2	178-5774-500
White			LC11WT2	178-0375-500	LC11WB2	178-5775-500
Clear (Colorless)	LC11CN2	178-0337-500				
Base (LH73/1)	359-8430-09-502					
Assemblies (LH73/2)▲	362-8430-09-702					

+ To be used only to enable the engraving of color legends when required. Only the legend will show in color. The black color is lusterless. See "Colored Legends" on Page 4.

**This lens cap series (exception LC11RB2 series) is available with RFI feature. They are to be used with LH73/2 base assembly only. To specify, change 11 in Type Designation number to 25 and Catalog Number prefix from 178- to 239-. Example: LC25BN2 239-0334-500.

▲ For use with LC25, LC26 and LC27 lens caps only.

See hot-stamped and engraved legend standards on Page 4.

Note: The inclusion of lamp MS25237-327 in MS25256, formerly designated by the use of odd numbered suffixes, -1 through -11 inclusive, is now superseded by suffix -327 (28 volts .04 amp) or -328 (6 volts .20 amp) after the even numbered dash number.

Examples:
MS25256-2-327;
MS25256-10-328.

MOUNT IN 15/32" CLEARANCE HOLE FRONT OF PANEL INSERTION WITH FIXED FLANGE

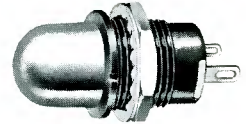

162-8430-0931-502 MS25256-6
359-8430-0931-502 LH73/1; LC12RN2

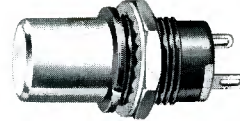

162-8430-1471-502 (No MS Number)
359-8430-1471-502 LH73/1; LC29RT2

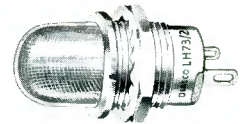

362-8430-0931-702 LH73/2; LC27RN2

MATERIALS AND FINISHES

- **Mounting Bushing:** Aluminum, black anodize finish. LH73/2 base assembly (362-8430-09-702): yellow iridescent chromate finish. Optional—clear anodize finish (no MS or LH designations).
- **Internal-tooth Lockwasher and Mounting Nut:** Steel, cadmium plated with yellow iridescent chromate finish.
- **Terminals:** Brass, hot tinned with elongated slot.

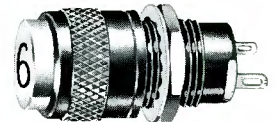

178-8430-0371-502
360-8430-0371-502 LH73/1; LC11RT2
363-8430-0331-702 LH73/2; LC25RN2

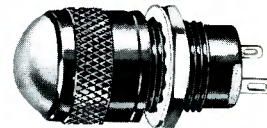

178-8430-0111-502

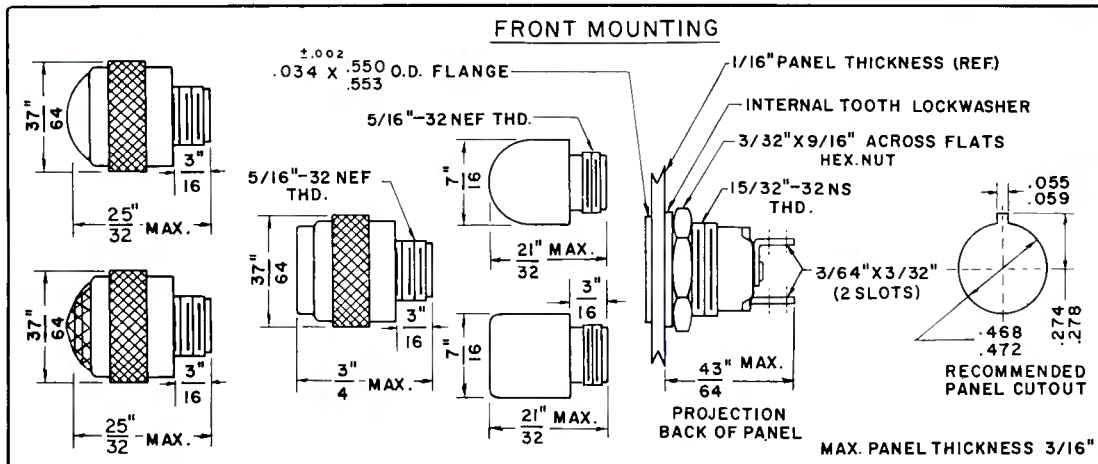

178-8430-2131-502

SAMPLES ON REQUEST AT ONCE—NO CHARGE

INCANDESCENT INDICATOR LIGHTS

NON-DIMMING OR DIMMING TYPE

MEET OR EXCEED ENVIRONMENTAL AND OPERATIONAL REQUIREMENTS

OF MIL-L-6723 AND MIL-L-3661B

General purpose, rugged, metal lens holder. Unscrews for easy lamp replacement.



MATERIALS AND FINISHES

- **Mounting Bushing:** Brass, black nickel finish. Optional (111-Series Assemblies only)—White nickel or chrome finish.
- **Mounting Nut:** Front or Back Mtg. (movable flange)—Brass, black nickel finish. Front Mtg. (fixed flange)—Brass, white nickel finish.
- **Flange Nut:** (movable)—Brass, black nickel finish. Optional—(111-Series Assemblies only)—White nickel or chrome finish.
- **Internal-tooth Lockwasher:** Phosphor bronze, white nickel finish.
- **Terminals:** Brass, hot tinned, with elongated slot.

MOUNT IN 15/32" CLEARANCE HOLE
FRONT OR BACK OF PANEL INSERTION
WITH MOVABLE FLANGE



111-3830-0111-201

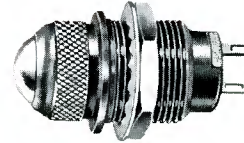

111-5030-0111-201

MOUNT IN 17/32" CLEARANCE HOLE
FRONT OF PANEL INSERTION
WITH FIXED FLANGE

MOUNT IN 15/32" CLEARANCE HOLE
FRONT OF PANEL INSERTION
WITH FIXED FLANGE

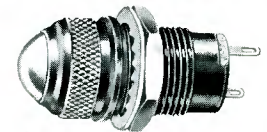

111-8430-0111-201

NON-DIMMING TYPE	LENS TYPE	LENS SURFACE	COMPLETE ASSEMBLIES	BASE ASSEMBLY	LENS CAP ASSEMBLIES
Front or Back Mtg. in 15/32" Clearance Hole	Convex	Unfrosted Back Frosted	111-3830-0131-201 111-3830-0111-201	101-3830-09-201	111-0131-200 111-0111-200
Front Mtg. in 17/32" Clearance Hole	Convex	Unfrosted Back Frosted	111-5030-0131-201 111-5030-0111-201	101-5030-09-201	111-0131-200 111-0111-200
Front Mtg. in 15/32" Clearance Hole	Convex	Unfrosted Back Frosted	111-8430-0131-201 111-8430-0111-201	101-8430-09-201	111-0131-200 111-0111-200

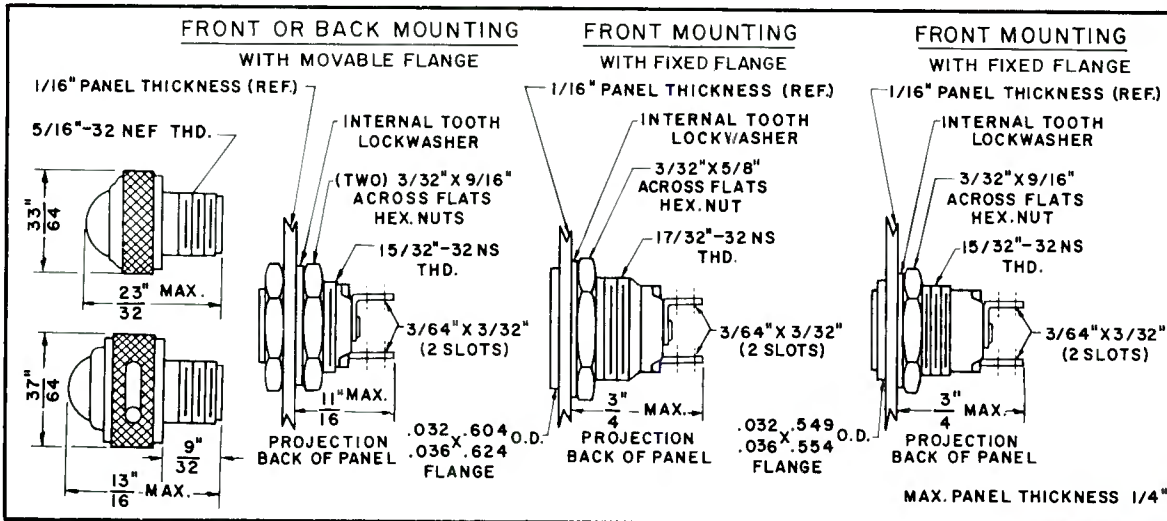

DIMMER TYPES

Choice of mechanical or polaroid dimming device. Polaroid produces some reduced intensity at all settings, but gives full diameter opening.

Mechanical varies opening size to complete blackout or has permanent small opening as in "semi-blackout" type.



108-3830-0111-201

MOUNT IN 15/32" CLEARANCE HOLE
FRONT OR BACK OF PANEL INSERTION
WITH MOVABLE FLANGE

DIMMER TYPE	LENS TYPE	LENS SURFACE	CATALOG NO. (FRONT OR BACK MTG. 15/32" CLEARANCE HOLE)	CATALOG NO. (FRONT MTG. 17/32" CLEARANCE HOLE)	CATALOG NO. (FRONT MTG. 15/32" CLEARANCE HOLE)	LENS CAP ASSEMBLIES
Complete Blackout	Convex	Unfrosted	108-3830-0131-201	108-5030-0131-201	108-8430-0131-201	108-0131-200
		Back Frosted	108-3830-0111-201	108-5030-0111-201	108-8430-0111-201	108-0111-200
Semi-Blackout	Convex	Unfrosted	109-3830-0131-201	109-5030-0131-201	109-8430-0131-201	109-0131-200
		Back Frosted	109-3830-0111-201	109-5030-0111-201	109-8430-0111-201	109-0111-200
Polaroid	Convex	Unfrosted	112-3830-0131-201	112-5030-0131-201	112-8430-0131-201	112-0131-200
		Back Frosted	112-3830-0111-201	112-5030-0111-201	112-8430-0111-201	112-0111-200
Base Assembly			101-3830-09-201	101-5030-09-201	101-8430-09-201	



109-5030-0111-201

LENS COLOR: The figure before the last dash in the catalog number indicates that the lens is RED. When a color other than red is desired, change this digit to a figure from the listing below. Note that white lenses are translucent and are always furnished unfrosted.

Red—1 . . . Green—2 . . . Yellow (Amber)—3 . . . Blue—4 . . .
White Translucent—5 . . . Light Yellow—6 . . . Clear (Colorless)—7.

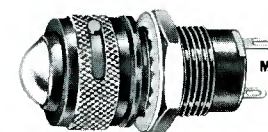

112-8430-0111-201

MOUNT IN 15/32" CLEARANCE HOLE
FRONT OF PANEL INSERTION
WITH FIXED FLANGE

INCANDESCENT INDICATOR LIGHTS

with ROUND or SQUARE Plastic Lens Caps



MATERIALS AND FINISHES

- **Lens Cap Assembly:** Plastic. Fitted with brass shank, white nickel plated.
- **Mounting Bushing (base assembly):** Aluminum, clear anodize finish; optional—black anodize finish.
- **Hardware:** For 1/2" Mounting: Round Knurled Flange Nut: Aluminum, clear anodized or (optional) black anodized... Mounting Nut—Aluminum, clear anodized... Internal-tooth Lockwasher—Phosphor bronze, white nickel plated... Lock Ring—Aluminum, chromate finish. For 15/32" Mounting: Mounting Nut and Internal-tooth Lockwasher: Steel, cadmium plated, with yellow iridescent chromate finish.
- **Terminals:** Brass, hot tinned with elongated slot.

OPTIONAL FINISH: To obtain the knurled flange ring on the 1/2" assembly... or mounting bushing for the 15/32" assembly in optional black anodize finish, change the "6" to "5" in the code number suffix. Examples: 183-9730-1473-502; 187-9830-1871-504.

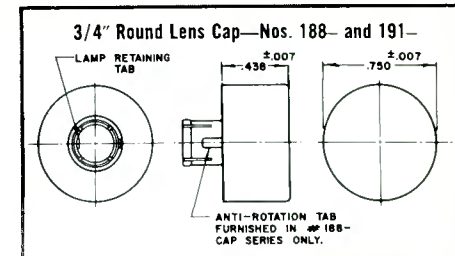
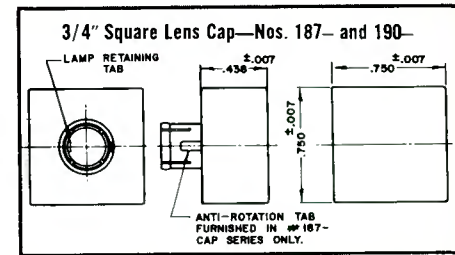
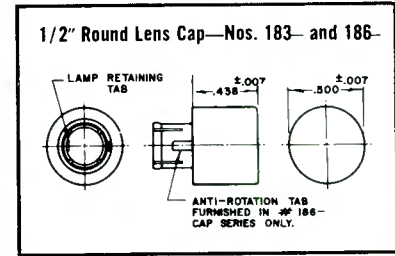
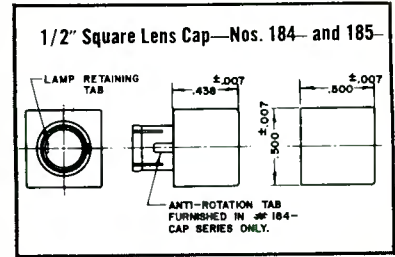

1/2" LENS COLOR COMBINATIONS	COMPLETE INDICATOR LIGHT ASSEMBLY WITH 1/2" ROTATABLE LENS CAP*				LENS CAP ASSEMBLY	
	FRONT MOUNTING IN 15/32" CLEARANCE HOLE		FRONT OR REAR MOUNTING IN 1/2" CLEARANCE HOLE		ROUND	SQUARE
	ROUND LENS	SQUARE LENS	ROUND LENS	SQUARE LENS		
Solid Color, Translucent Face & Sides	183-9730-1471-602	185-9730-1871-602	183-9830-1471-604	185-9830-1871-604	183-1471	185-1871
Solid Color** Transparent Face & Sides	183-9730-1431-602	—	183-9830-1431-604	—	183-1431	—
Translucent Colored Face, Black Opaque Sides	183-9730-5071-602	185-9730-5071-602	183-9830-5071-604	185-9830-5071-604	183-5071	185-5071
Translucent Colored Face, Gray Opaque Sides	183-9730-5171-602	185-9730-5171-602	183-9830-5171-604	185-9830-5171-604	183-5171	185-5171
Translucent Colored Face, White Opaque Sides	183-9730-5271-602	185-9730-5271-602	183-9830-5271-604	185-9830-5271-604	183-5271	185-5271
Translucent White Face, Black Opaque Sides, Underlying Colored Filter	183-9730-5061-602	185-9730-5061-602	183-9830-5061-604	185-9830-5061-604	183-5061	185-5061
Translucent White Face, Gray Opaque Sides, Underlying Colored Filter	183-9730-5161-602	185-9730-5161-602	183-9830-5161-604	185-9830-5161-604	183-5161	185-5161
Translucent White Face, White Opaque Sides, Underlying Colored Filter	183-9730-5261-602	185-9730-5261-602	183-9830-5261-604	185-9830-5261-604	183-5261	185-5261
Transparent Face With Internal Diffusing Rings, White Opaque Sides	183-9730-5291-602	—	183-9830-5291-604	—	183-5291	—
Black Opaque Overlay On Translucent Colored Face, Black Opaque Sides	183-9730-5371-602	185-9730-5371-602	183-9830-5371-604	185-9830-5371-604	183-5371	185-5371
Gray Opaque Overlay On Translucent Colored Face, Gray Opaque Sides	183-9730-5471-602	185-9730-5471-602	183-9830-5471-604	185-9830-5471-604	183-5471	185-5471
Black Opaque Overlay On Translucent Colored Face, White Opaque Sides	183-9730-5571-602	185-9730-5571-602	183-9830-5571-604	185-9830-5571-604	183-5571	185-5571
Gray Opaque Overlay On Translucent Colored Face, White Opaque Sides	183-9730-5671-602	185-9730-5671-602	183-9830-5671-604	185-9830-5671-604	183-5671	185-5671
Base Assembly	183-9730-14-602		183-9830-14-604		—	—

*The Catalog Nos. listed above are for units with rotatable lens caps assemblies. To designate non-rotatable (keyed) lens caps, change the prefix to 184-(Square) or 186-(Round). Examples: 184-9730-1871-602; 186-9830-5075-604.

**This series only is also available in clear colorless and is designated by -1437-.

3/4" LENS CAPS	
Number of Characters	Character Height
1 (one line)	.266
2 (one line)	.203
3 (one line)	.172
4 (one line)	.141
5 (one line)	.109
6 (one line)	.078

1/2" LENS CAPS	
Number of Characters	Character Height
1 (one line)	.203
2 (one line)	.172
3 (one line)	.109
4 (one line)	.078

HOT-STAMPED or ENGRAVED LEGENDS: 1/2" lens caps may be engraved and filled, or hot-stamped with up to 2 lines with a maximum of 4 digits per line. 3/4" lens caps can display a maximum of 4 lines with 6 digits per line.

Standard sizes for one line legends are listed in the two tables below. Standard marking is in black. Engraving and filling in white or hot-stamping in silver may be preferred on red,

green and blue lens caps for better contrast and legibility when unlighted.

Unless otherwise specified, these standard sizes will be provided in a uniform manner per order—i.e., the size of type will be determined by the longest legend indicated in each individual order. Special legend configurations and sizes may be furnished on application.

	Gray Opaque Overlay on Translucent Colored Face, Gray Opaque Sides		Translucent Colored Face, Black Opaque Sides
	Black Opaque Overlay on Translucent Colored Face, Black Opaque Sides		Translucent Colored Face, White Opaque Sides



WATER-TIGHT

INCANDESCENT INDICATOR LIGHTS

with RETAINED O-RING SEALS

WATER-TIGHT, OIL-TIGHT, DUST-TIGHT ON THE FACE OF THE PANEL

TWO TERMINALS—FULLY INSULATED

MEET OR EXCEED ENVIRONMENTAL AND OPERATIONAL REQUIREMENTS
OF MIL-L-6723 AND MIL-L-3661B

MOUNT IN 15/32" CLEARANCE HOLE
FRONT OF PANEL INSERTION
WITH FIXED FLANGE



177-8430-0931-503

MATERIALS AND FINISHES

- **Mounting Bushing:** Aluminum, black anodize finish. Optional—clear anodize finish.
- **Internal-tooth Lockwasher and Mounting Nut:** Steel, cadmium plated with yellow iridescent chromate finish.
- **Terminals:** Brass, hot tinned, with elongated slot.

DIMMER TYPE



174-8430-0131-203
175-8430-0131-203

MATERIALS AND FINISHES

- **Mounting Bushing:** Brass, black nickel finish.
- **Mounting Nut:** Brass, white nickel finish.
- **Internal-tooth Lockwasher:** Phosphor bronze, white nickel finish.
- **Terminals:** Brass, hot tinned with elongated slot.

LENS COLOR	COMPLETE ASSEMBLIES		LENS CAP ASSEMBLIES	
	TRANSPARENT COLORS	TRANSLUCENT COLORS	TRANSPARENT COLORS	TRANSLUCENT COLORS
Red	177-8430-0931-503	177-8430-0971-503	177-0931-003	177-0971-003
Green	177-8430-0932-503	177-8430-0972-503	177-0932-003	177-0972-003
Yellow (Amber)	177-8430-0933-503	177-8430-0973-503	177-0933-003	177-0973-003
Blue	177-8430-0934-503	177-8430-0974-503	177-0934-003	177-0974-003
White (Translucent)	177-8430-0935-503	177-8430-0975-503	177-0935-003	177-0975-003
Light Yellow	177-8430-0936-503	177-8430-0976-503	177-0936-003	177-0976-003
Clear (Colorless)	177-8430-0937-503		177-0937-003	
Base Assembly	177-8430-09-503	177-8430-09-503		

MECHANICAL DIMMER TYPE	LENS TYPE	LENS SURFACE	COMPLETE ASSEMBLIES	LENS CAP ASSEMBLIES
Complete Blackout	Convex	Unfrosted	174-8430-0131-203	174-0131-203
		Back Frosted	174-8430-0111-203	174-0111-203
Semi-Blackout	Convex	Unfrosted	175-8430-0131-203	175-0131-203
		Back Frosted	175-8430-0111-203	175-0111-203
Base Assembly			101-8430-09-203	

LENS COLOR: The figure before the last dash in the catalog number indicates that the lens is RED. When a color other than red is desired, change this digit to a figure from the listing below. Note that white lenses are translucent and are always furnished unfrosted.

Red—1 ... Green—2 ... Yellow (Amber)—3 ... Blue—4 ...
White Translucent—5 ... Light Yellow—6 ... Clear (Colorless)—7.

SAMPLES ON REQUEST AT ONCE—NO CHARGE

MIL-L-3661B

(See charts at top of facing page.)

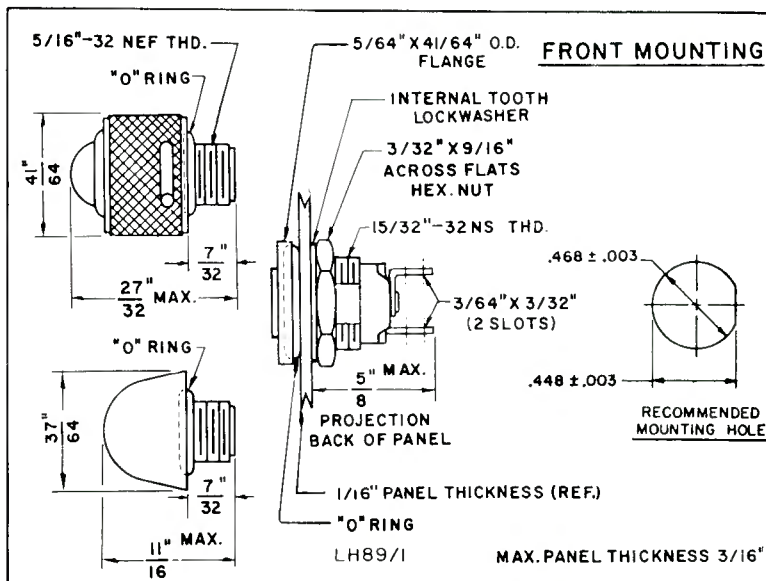
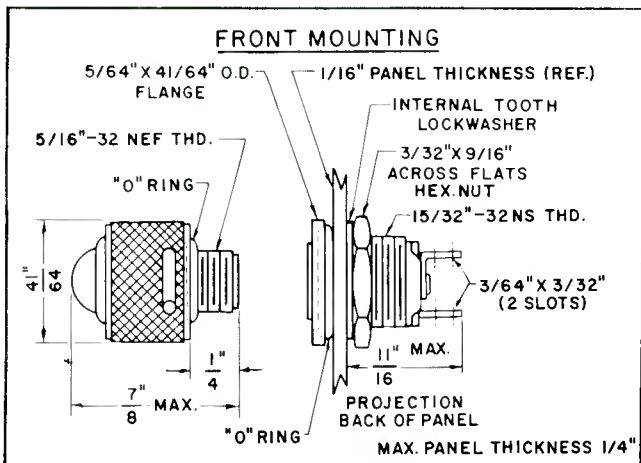
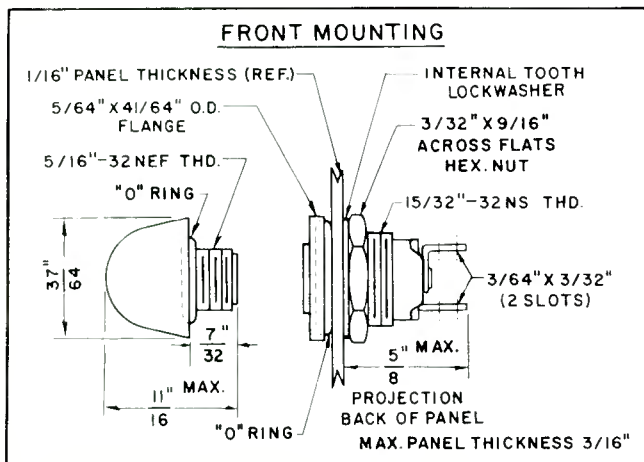

WATER-TIGHT INCANDESCENT INDICATOR LIGHTS

with RETAINED O-RING SEALS

WATER-TIGHT, OIL-TIGHT, DUST-TIGHT ON THE FACE OF THE PANEL

These assemblies conform to MIL-L-3661B. Outline drawings and Materials and Finishes for these indicators are found on the facing page.



LENS CAP COLOR	STOVEPIPE LENS CAP			
	NON-DIFFUSING		TRANSLUCENT	
	TYPE DESIG.	CATALOG NUMBER	TYPE DESIG.	CATALOG NUMBER
Red	LC35RN2	128-0931-003	LC35RT2	128-0971-003
Green	LC35GN2	128-0932-003	LC35GT2	128-0972-003
Yellow (Amber)	LC35YN2	128-0933-003	LC35YT2	128-0973-003
Blue	LC35BN2	128-0934-003	LC35BT2	128-0974-003
White	---	---	LC35WT2	128-0975-003
Clear (Colorless)	LC35CN2	128-0937-003	---	---
Base Assembly (LH89/1)		367-8430-09-503		

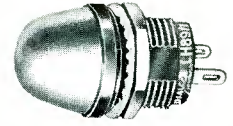

367-8430-0931-503
LH89/1; LC35RN2

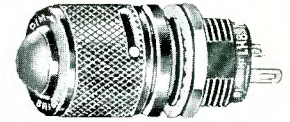

368-8430-0111-203
LH89/1; LC36RD2

LENS CAP COLOR	CONVEX LENS CAP—COMPLETE BLACKOUT				CONVEX LENS CAP—SEMI-BLACKOUT			
	GLASS—DIFFUSING		PLASTIC—DIFFUSING		GLASS—DIFFUSING		PLASTIC—DIFFUSING	
	TYPE DESIG.	CATALOG NUMBER	TYPE DESIG.	CATALOG NUMBER	TYPE DESIG.	CATALOG NUMBER	TYPE DESIG.	CATALOG NUMBER
Red	LC36RD1	160-2211-203	LC36RD2	160-0111-203	LC37RD1	161-2211-203	LC37RD2	161-0111-203
Green	LC36GD1	160-2212-203	LC36GD2	160-0112-203	LC37GD1	161-2212-203	LC37GD2	161-0112-203
Yellow (Amber)	LC36YD1	160-2213-203	LC36YD2	160-0113-203	LC37YD1	161-2213-203	LC37YD2	161-0113-203
Blue	LC36BD1	160-2214-203	LC36BD2	160-0114-203	LC37BD1	161-2214-203	LC37BD2	161-0114-203
White	LC36WT1	160-2235-203+	---	---	LC37WT1	161-2235-203+	---	---
Clear (Colorless)	LC36CD1	160-2217-203	LC36CD2	160-0117-203	LC37CD1	161-2217-203	LC37CD2	161-0117-203
Base Assembly (LH89/1)		367-8430-09-503						

+ Translucent

**MOUNT IN 15/32" CLEARANCE HOLE
FRONT OF PANEL INSERTION
WITH FIXED FLANGE
With Built-in Resistor**

WATER-TIGHT NEON INDICATOR LIGHTS

with RETAINED O-RING SEALS

WATER-TIGHT, OIL-TIGHT, DUST-TIGHT ON THE FACE OF THE PANEL

When connecting a neon light to a circuit having one side grounded, always connect the hot side of the circuit to the terminal marked + (Center Contact).

LENS COLOR	COMPLETE ASSEMBLIES			
	WITH BUILT-IN RESISTOR		WITHOUT BUILT-IN RESISTOR	LENS CAP ASSEMBLIES
	ACCOMMODATE C7A (NE-2D) LAMP	ACCOMMODATE C9A (NE-2J) LAMP		
Red	181-8836-0931-553	181-8864-0931-513	181-8536-0931-503	181-0931-003
Yellow (Amber)	181-8836-0933-553	181-8864-0933-513	181-8536-0933-503	181-0933-003
White (Translucent)	181-8836-0935-553	181-8864-0935-513	181-8536-0935-503	181-0935-003
Light Yellow	181-8836-0936-553	181-8864-0936-513	181-8536-0936-503	181-0936-003
Clear (Colorless)	181-8836-0937-553	181-8864-0937-513	181-8536-0937-503	181-0937-003
Base Assembly	181-8836-09-553	181-8864-09-513	181-8536-09-503	---

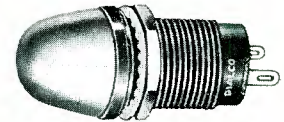

181-8836-0931-553

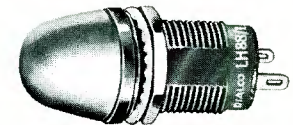

366-8836-0931-553
LH88/1; LC33RN2

Without Built-in Resistor



181-8536-0931-503

MIL-L-3661B

LENS CAP COLOR	STOVEPIPE LENS CAP	
	NON-DIFFUSING	
	TYPE DESIG.	CATALOG NUMBER
Red	LC33RN2	130-0931-003
Yellow (Amber)	LC33YN2	130-0933-003
White	LC33WT2	130-0935-003
Clear (Colorless)	LC33CN2	130-0937-003
Base Assemblies:		
LH88/1	366-8836-09-553	
LH88/2	366-8864-09-523	

MATERIALS AND FINISHES

- **Mounting Bushing:** Aluminum, black anodize finish. Optional—clear anodize finish.
- **Internal-tooth Lockwasher and Mounting Nut:** Steel, cadmium plated with yellow iridescent chromate finish.
- **Terminals:** Brass, hot tinned with elongated slot.

**SAMPLES ON REQUEST
AT ONCE—NO CHARGE**

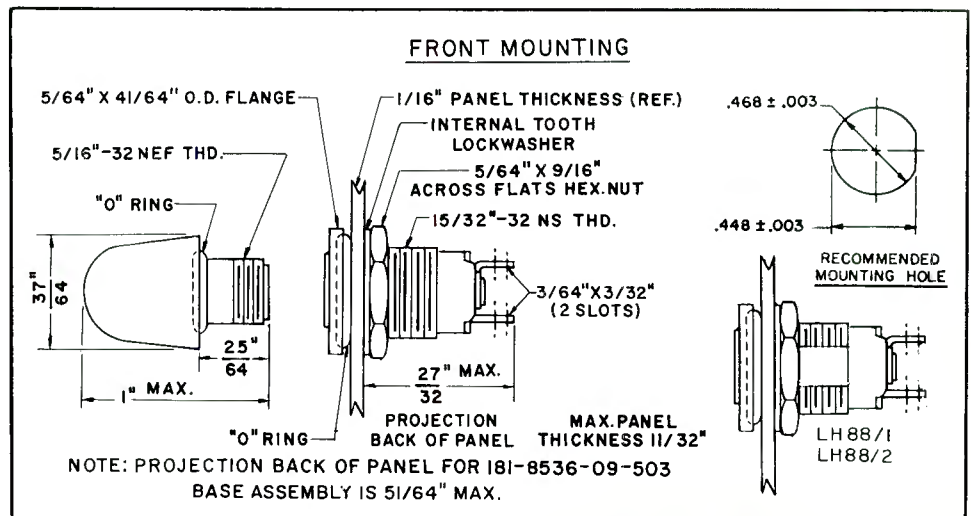



NEON INDICATOR LIGHTS

TWO TERMINALS—FULLY INSULATED

MEET OR EXCEED ENVIRONMENTAL AND OPERATIONAL REQUIREMENTS OF MIL-L-6723 AND MIL-L-3661B

CONFORM TO MS25257

WITH BUILT-IN RESISTOR

(U.S. Pat. No. 2,421,321)

MOUNT IN 15/32" CLEARANCE HOLE
FRONT OF PANEL INSERTION
WITH FIXED FLANGE

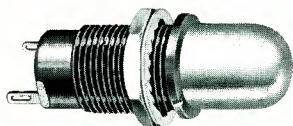

137-8836-0931-552 MS25257-4
361-8836-0931-552
LH74/1; LC13RN2

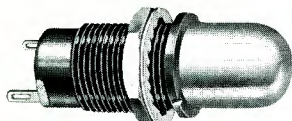

137-8864-0931-512
361-8864-0931-522
LH74/2 LC13RN2

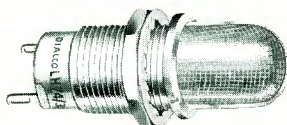

364-8836-0931-752
LH74/3, LC28RN2

MATERIALS AND FINISHES

- **Mounting Bushing:** Aluminum, black anodize finish. LH74/3 (364-8836-09-752) and LH74/4 (364-8864-09-722) base assemblies: yellow iridescent chromate finish. Optional—clear anodize finish.
- **Internal-tooth Lockwasher and Mounting Nut:** Steel, cadmium plated with yellow iridescent chromate finish.
- **Terminals:** Brass, hot tinned with elongated slot.

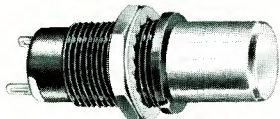

137-8836-1531-552

These assemblies are similar in every respect to the MS assemblies (137-8836-0931-552 Series) above, except that they offer optional features not covered by MS. Finishes: Standard—black anodize; optional—clear anodize. Lamps—C7A (NE-2D) standard brightness for 105-125 volts AC or DC; C9A (NE-2J) high brightness for 110-125 volts AC only. Resistor values—recommended ohmic values for two levels of operation are given on this page.

SAMPLES ON REQUEST—
AT ONCE—NO CHARGE

When connecting a neon light to a circuit having one side grounded, always connect the hot side of the circuit to the terminal marked + (Center Contact).

Use T-2 Neon Glow Lamps, designated as C7A (NE-2D) for standard brightness; C9A (NE-2J) for high brightness. Since Neon lamps require a resistor (or other ballast device) to limit the lamp current, DIALCO makes the required resistor an integral part of the unit—built-in (a patented Dialco feature—U.S. Pat. No. 2,421,321) of the Series 137-8836-0931-552 (shown on Page 10) and 181-8836-0931-553 (shown on Page 9). In all other listed Series, an external resistor must be added. The recommended ohmic values for two levels of operation are given in the following table:

FOR C7A (NE-2D) AT 105-125 VOLTS AC OR DC	
Bright Light	Long Life
■ 62,000 ohms	100,000 ohms
FOR C9A (NE-2J) HIGH BRIGHTNESS AT 110-125 VOLTS AC ONLY	
Bright Light	Long Life
■ 22,000 ohms	33,000 ohms

■ Standard values of patented built-in resistors; other values optional.

FEATURES

- **Rugged-phenolic insulated:** The socket, lamp, and all connections are well insulated from the mounting bushing by means of phenolic material of military specification grade.

- Available for mounting from FRONT or BACK of panel in 15/32" clearance hole; also from FRONT of panel in 17 and 15/32" clearance hole.
- Ultra-compact; conserves space and weight.
- Lens cap assembly unscrews from front of panel for replacement of the lamp.
- The shank of the lens holder is crimped in 3 evenly spaced places to secure the lamp.
- Anti-rotation (locked) construction: See description on following page.
- Choice of 5 lens colors.
- Order complete with lamp. Specify lamp number.

HOW TO DESIGNATE THE THREE DIGIT CATALOG NUMBER SUFFIX (-XX)

FINISH	RESISTOR	HARDWARE
-1 white nickel	0—none	0—none
-2 black nickel	1-22K	1—brass
-3 polished chrome	2-27K	2—steel
-5 black anodize	3-33K	3—water-t on the l of the
-6 clear anodize	5-62K	
	7-100K	

NOTE: The part numbers given in this catalog indicate standard indicators. The above table provides the standard and optional designations for Resistor and Hardware (for Neon Assemblies only) where appropriate. Example: 181-8864-0933-633 (clear anodize finish, 33K resistor, wa construction).

CATALOG NO. WITHOUT LAMP	MS NO. WITHOUT LAMP*	MS NO. WITH LAMP MS25252-C7A (NE-2D)*	LENS COLOR
137-8836-0933-552 ■	MS25257-2	MS25257-1	Aviation Yellow
137-8836-0931-552 ■	MS25257-4	MS25257-3	Identification Red
137-8836-0937-552 ■	MS25257-6	MS25257-5	Clear (Colorless)

■ With patented built-in resistor: 62K ± 10%.

*MARKING: The Part No. marked on the assembly is the Part No. for the complete assembly less lamp.

LENS CAP COLOR	STOVEPIPE LENS CAP	
	NON-DIFFUSING	
	TYPE DESIG.	CATALOG NUMBER
Red	LC13RN2	137-0931
Yellow (Amber)	LC13YN2	137-0933
White	LC13WT2	137-0935
Clear (Colorless)	LC13CN2	137-0937
Base Assemblies:		
	LH74/1	361-8836-09-552
	LH74/2	361-8864-09-522

LENS CAP COLOR	STOVEPIPE LENS CAP (with RFI feature)	
	NON-DIFFUSING	
	TYPE DESIG.	CATALOG NUMBER
Red	LC28RN2	234-0931
Yellow (Amber)	LC28YN2	234-0933
White	LC28WT2	234-0935
Clear (Colorless)	LC28CN2	234-0937
Base Assemblies:		
	LH74/3	364-8836-09-752
	LH74/4	364-8864-09-722

LENS COLOR	COMPLETE ASSEMBLIES				LENS CAP ASSEMBLY	
	ACCOMMODATE C7A (NE-2D) LAMP		ACCOMMODATE C9A (NE-2J) LAMP		STOV'P	CYL.
	STOVEPIPE	CYLINDRICAL	STOVEPIPE	CYLINDRICAL		
Identification Red	137-8836-0931-552	137-8836-1531-552	137-8864-0931-512	137-8864-1531-512	137-0931	137-15
Aviation Yellow	137-8836-0933-552	137-8836-1533-552	137-8864-0933-512	137-8864-1533-512	137-0933	137-15
White	137-8836-0935-552	137-8836-1535-552	137-8864-0935-512	137-8864-1535-512	137-0935	137-15
Light Yellow	137-8836-0936-552	137-8836-1536-552	137-8864-0936-512	137-8864-1536-512	137-0936	137-15
Clear (Colorless)	137-8836-0937-552	137-8836-1537-552	137-8864-0937-512	137-8864-1537-512	137-0937	137-15
Base Assembly	137-8836-09-552	137-8836-09-552	137-8864-09-512	137-8864-09-512		

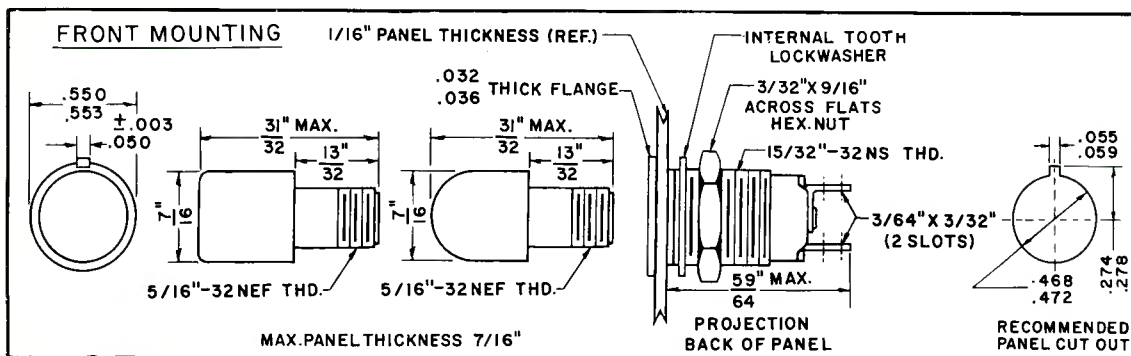

NEON INDICATOR LIGHTS

with STOVEPIPE or ROTATABLE CYLINDRICAL LENS



This omnidirectional stovepipe lens is molded of high heat plastic to a special design: About two-thirds of the lens is "fluted," and the remaining portion is smooth. This produces clear light framed by a sparkling "halo" when viewed from the front. Softer light is afforded along the "fluted" sides. The C7A (NE-2D) or C9A (NE-2J) Neon Lamp enters high into the lens for greater effectiveness.

Whether used on the front insertion or the back insertion assembly, the stovepipe or cylindrical lens cap is readily removable from the front of the panel, thus making the lamp accessible for easy replacement.

ROTATABLE LENS

Specially designed spring mounting facilitates rotation of lens and alignment of legend—after installation of the Indicator Light. See description of "Legends" and "Size of Type for Legends" below.

MATERIALS AND FINISHES

- **Mounting Bushing and Lens Holder:** Brass, black nickel finish. Optional — White nickel or chrome finish.
- **Mounting Nut:** Front or Back Mtg. (movable flange) — Brass, black nickel finish. Optional — White nickel finish. Front Mtg. (fixed flange) — Brass, white nickel finish.
- **Flange Nut:** (movable) — Brass, black nickel finish. Optional — White nickel or chrome finish.
- **Internal-tooth Lockwasher:** Phosphor bronze, white nickel finish.
- **Terminals:** Brass, hot tinned, with elongated slot.

WITHOUT BUILT-IN RESISTOR

MOUNT IN 15/32" CLEARANCE HOLE
FRONT OR BACK OF PANEL INSERTION
WITH MOVABLE FLANGE

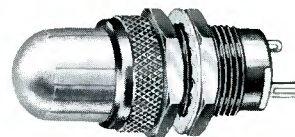

145-3836-0991-201

MOUNT IN 17/32" CLEARANCE HOLE
FRONT OF PANEL INSERTION
WITH FIXED FLANGE

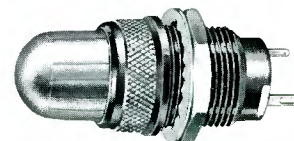

145-5036-0991-201

MOUNT IN 15/32" CLEARANCE HOLE
FRONT OR BACK OF PANEL INSERTION
WITH MOVABLE FLANGE

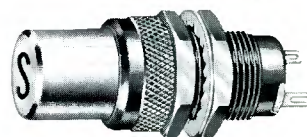

138-3836-1431-201

MOUNT IN 17/32" CLEARANCE HOLE
FRONT OF PANEL INSERTION
WITH FIXED FLANGE

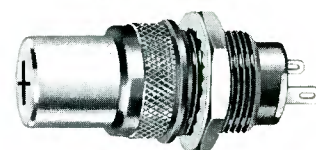

138-5036-1431-201

LENS COLOR	CATALOG NUMBER FRONT OR BACK MTG. SERIES		CATALOG NUMBER FRONT MTG. SERIES		LENS CAP ASSEMBLIES	
	STOVEPIPE LENS	CYLINDRICAL LENS	STOVEPIPE LENS	CYLINDRICAL LENS	STOVEPIPE	CYLINDRICAL
Red	145-3836-0991-201	138-3836-1431-201	145-5036-0991-201	138-5036-1431-201	145-0991-200	138-1431-200
Yellow (Amber)	145-3836-0993-201	138-3836-1433-201	145-5036-0993-201	138-5036-1433-201	145-0993-200	138-1433-200
White	145-3836-0995-201	138-3836-1435-201	145-5036-0995-201	138-5036-1435-201	145-0995-200	138-1435-200
Light Yellow	145-3836-0996-201	138-3836-1436-201	145-5036-0996-201	138-5036-1436-201	145-0996-200	138-1436-200
Clear (Colorless)	145-3836-0997-201	138-3836-1437-201	145-5036-0997-201	138-5036-1437-201	145-0997-200	138-1437-200
Base Assembly	101-3830-09-201	101-3830-09-201	101-5030-09-201	101-5030-09-201		

SIZE OF TYPE FOR LEGENDS

HOT-STAMPED & ENGRAVED LEGENDS (Flat lens only)	
Number of Characters	Character Height
1	.203
2	.172
3	.141
4	.109
5	.078

STANDARD: Black letters. White, red, green, blue or silver can be supplied on request.

Unless otherwise specified, these standard sizes will be provided in a uniform manner per order —i.e., the size of type will be determined by the largest legend in each individual order.

COLORED LEGENDS—See Page 4 for details.

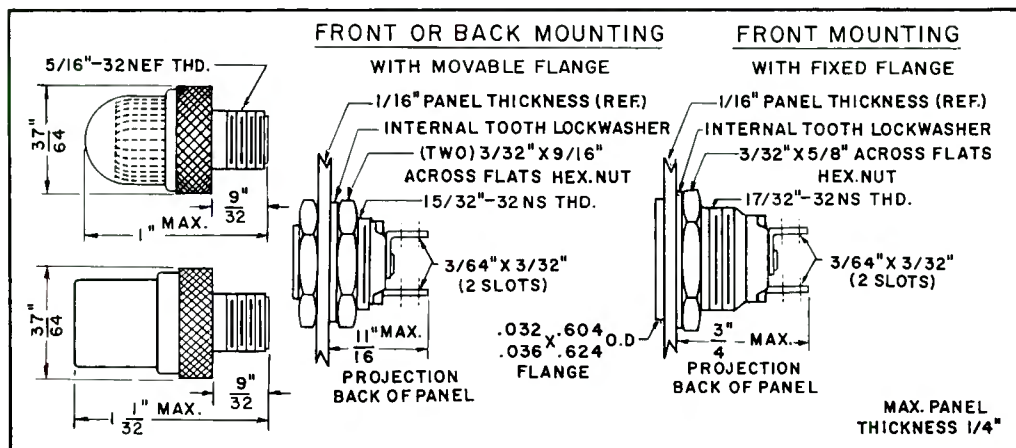

When connecting a neon light to a circuit having one side grounded, always connect the hot side of the circuit to the terminal marked + (Center Contact).

SAMPLES ON REQUEST
AT ONCE—NO CHARGE



NEON INDICATOR LIGHTS

PLASTIC LENS - OMNIDIRECTIONAL

MEET OR EXCEED ENVIRONMENTAL AND OPERATIONAL REQUIREMENTS
OF MIL-L-6723 AND MIL-L-3661B

MOUNT IN 15/32" CLEARANCE HOLE
FRONT OR BACK OF PANEL INSERTION
WITH MOVABLE FLANGE

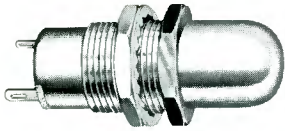

137-7236-0931-201



137-7236-1531-201

All assemblies on this page are furnished without built-in resistor. Similar units with built-in resistors are described on Page 10.

MOUNT IN 17/32" CLEARANCE HOLE
FRONT OF PANEL INSERTION
WITH FIXED FLANGE

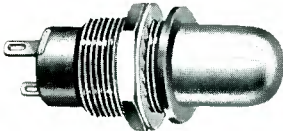

137-7336-0931-201

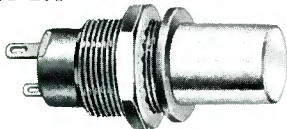

137-7336-1531-201

MOUNT IN 15/32" CLEARANCE HOLE
FRONT OF PANEL INSERTION
WITH FIXED FLANGE

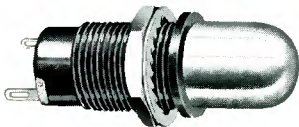

137-8536-0931-201

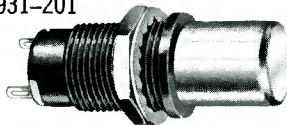

137-8536-1531-201

Omnidirectional lenses in Signal Colors. . . These unique lenses are molded of high heat plastic. They radiate light in all directions. Their heavy wall is reinforced by a threaded brass insert. This fitting receives the lamp and screws into the internal thread of the bushing. The bulb enters well into the plastic lens for best effectiveness.

Whether used on the front or back insertion assembly, the lens is readily removable from the front of the panel, thus making lamp accessible for easy replacement.

MATERIALS AND FINISHES (For Front or Back Mtg. Assemblies)

- Mounting Bushing: Brass, white nickel or chrome finish.
- Mounting Nut: (movable flange)—Brass, white nickel finish.
- Flange Nut: (movable)—Brass, black nickel finish. Optional—White nickel or chrome finish.
- Internal-tooth Lockwasher: Phosphor bronze, white nickel finish.
- Terminals: Brass, hot tinned, with elongated slot.

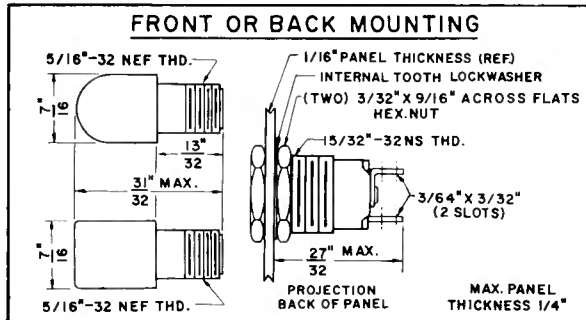

ASSEMBLY TYPE	LENS FINISH	CATALOG NUMBER		BASE ASSEMBLY	LENS CAP ASSEMBLIES	
		LENS SHAPE STOVEPIPE	LENS SHAPE CYLINDRICAL		STOV'P	CYL.
Front or Back Mtg. in 15/32" Clearance Hole	Transparent	137-7236-0931-201	137-7236-1531-201	137-7236-09-201	137-0931	137-1531
Front Mtg. in 17/32" Clearance Hole	Transparent	137-7336-0931-201	137-7336-1531-201	137-7336-09-201	137-0931	137-1531
Front Mtg. in 15/32" Clearance Hole	Transparent	137-8536-0931-201	137-8536-1531-201	137-8536-09-201	137-0931	137-1531

NOTE: The figure before the last dash in the catalog number indicates that the lens is RED. When a color other than red is desired, change this digit from the listing below. Red-1...Yellow (Amber)-3...White-5...Light Yellow-6...Clear (Colorless)-7.

MATERIALS AND FINISHES (For Front Mtg. Assemblies)

- Mounting Bushing: Brass, black nickel finish. Optional—White nickel or chrome finish.
- Mounting Nut: (fixed flange)—Brass, white nickel finish.
- Internal-tooth Lockwasher: Phosphor bronze, white nickel finish.
- Terminals: Brass, hot tinned with elongated slot.

When connecting a neon light to a circuit having one side grounded, always connect the hot side of the circuit to the terminal marked + (Center Contact).

SAMPLES ON REQUEST AT ONCE - NO CHARGE

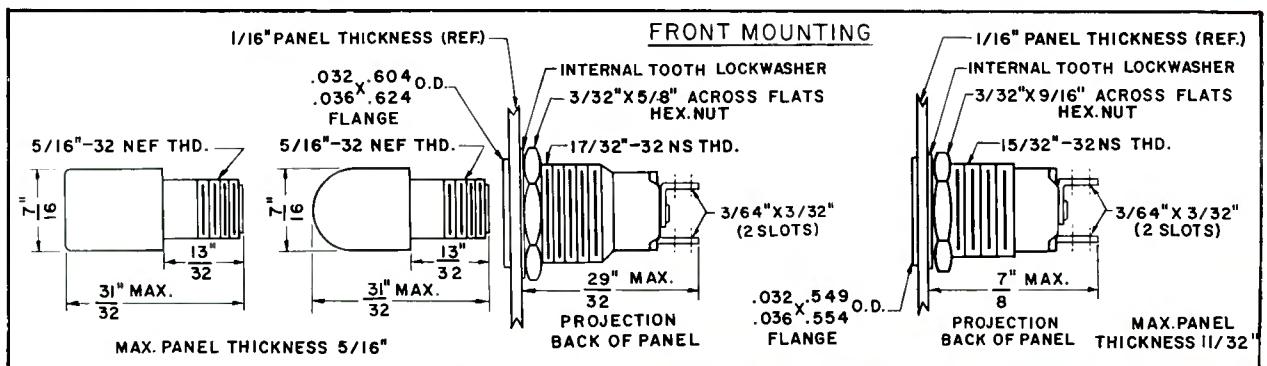



7 MINIATURE, LARGE
& MISC. INDICATORS

7
MINIATURE, LARGE
& MISC. INDICATORS



DIALIGHT

***Miniature & Large Indicator Lights
Incandescent & Neon***

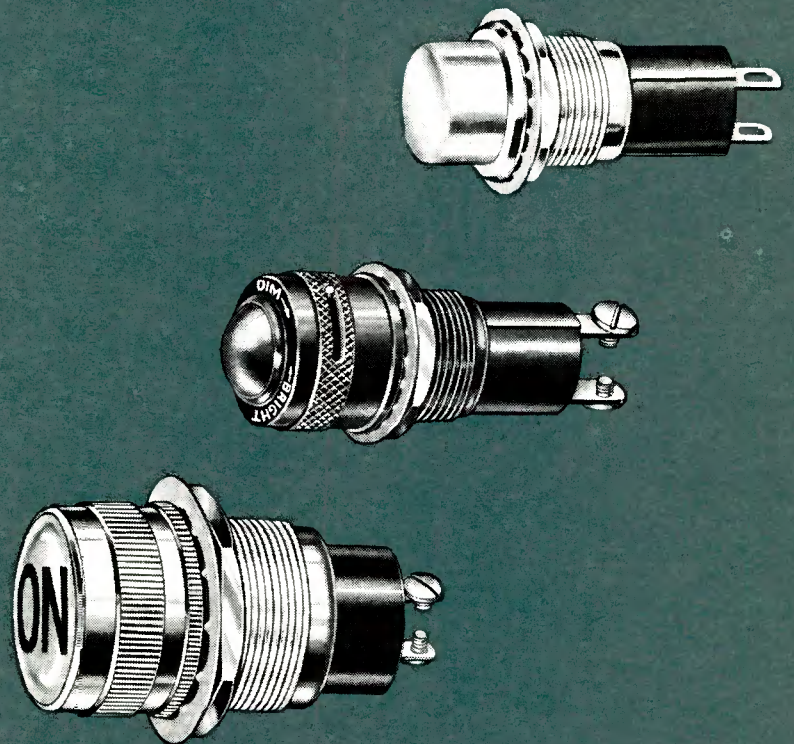

A NORTH AMERICAN PHILIPS COMPANY

CATALOG L-161K



INDICATOR LIGHTS with BUILT-IN RESISTOR FOR T-3 1/4 NEON GLOW LAMPS B2A (NE-51H) & B1A (NE-51)

For Mounting in 11/16" Clearance Hole

These series indicator lights meet or exceed requirements of MIL-L-3661.

When Connecting a Neon Light to a Circuit Having One Side Grounded, Always Connect the Hot Side of the Circuit to the Terminal Marked + (Center Contact)



B1A (NE-51)
B2A (NE-51H)

FEATURES

- May be directly connected to commercial circuits up to 250V.
- Accommodate rugged, long life (rated over 25,000 hours) standard brightness B1A (NE-51) or high brightness B2A (NE-51H) Neon Glow Lamps.
- The necessary current-limiting resistor is "Built-in" (A patented Dialco feature—U.S. Pat. No. 2,421,321)—as an integral part of these assemblies.
- Lens cap assemblies afford 180° light spread for maximum visibility.

BUILT-IN RESISTOR VALUES for the B2A (NE-51H) and B1A (NE-51) NEON GLOW LAMPS (Values in Ohms)

B2A (NE-51H) High Brightness			B1A (NE-51) Standard Brightness	
Circuit volts applied to terminals 110-125 AC 210-250 AC-DC			Circuit volts applied to terminals 105-125 AC-DC	
BRIGHT LIGHT	■ 22,000	■ 68,000	BRIGHT LIGHT	■ 56,000
LONG LAMP LIFE	33,000	100,000	LONG LAMP LIFE	100,000

■ Standard values of patented built-in resistors. (Other values optional). Note: The B2A (NE-51H) Neon Glow Lamp is not recommended for use on DC circuits under 160V.

Ratings of lamps are taken from published catalogs of leading lamp manufacturers.

ORDER COMPLETE WITH LAMP so that you will be assured of receiving the indicator light and correct lamp at one time for immediate use.

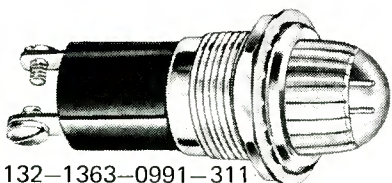

132-1363-0991-311
Screw-in lens cap

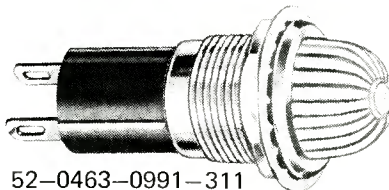

52-0463-0991-311
Screw-in lens cap

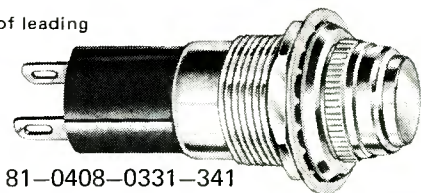

81-0408-0331-341
Screw-in lens cap

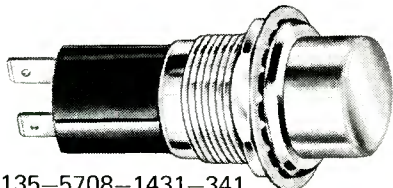

135-5708-1431-341
Screw-in lens cap

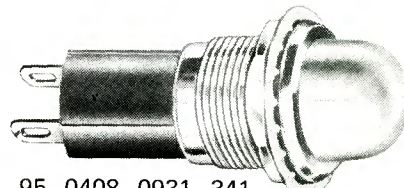

95-0408-0931-341
Screw-in lens cap

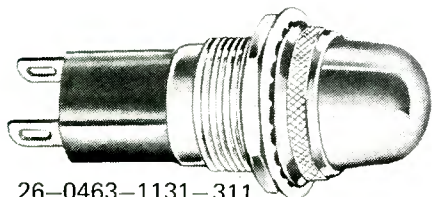

26-0463-1131-311
Screw-in lens cap

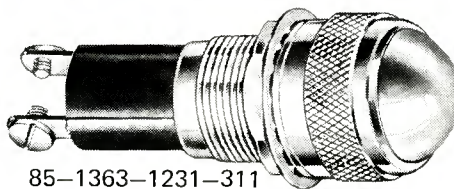

85-1363-1231-311
Screw-on lens cap

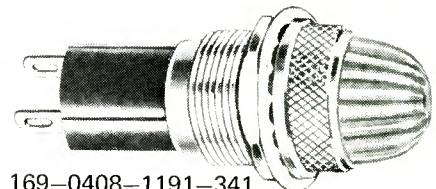

169-0408-1191-341
Screw-on lens cap

PER MIL-L-3661B

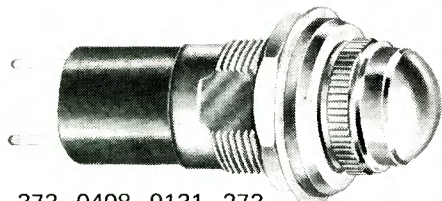

373-0408-0131-273
Screw-in lens cap

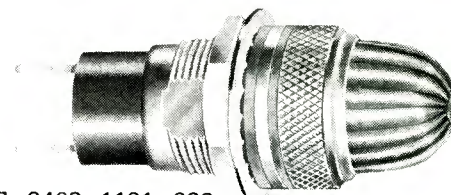

377-0463-1191-223
Screw-on lens cap

INDICATOR LIGHTS with BUILT-IN RESISTOR

FOR T-3 1/4 NEON GLOW LAMPS B2A (NE-51H) & B1A (NE-51)



For Mounting in 11/16" Clearance Hole

When Connecting a Neon Light to a Circuit Having One Side Grounded, Always Connect the Hot Side of the Circuit to the Terminal Marked + (Center Contact).

MATERIALS AND FINISHES

- **Mounting Bushing and Lens Holder:** Standard—Brass, polished chrome finish. Optional—White nickel, black nickel or satin chrome finish.
- **Mounting Nut:** Brass, white nickel finish.
- **Internal-tooth Lockwasher:** Phosphor bronze, white nickel finish.
- **Terminals:** Soldering—Brass, hot tinned with elongated slot. Screw—Brass, white nickel finish. Quick Connect—Brass, tinned. Mate with standard female receptacles.

LENS HOLDER AND PLASTIC LENS STYLE	LENS FINISH	FOR B2A (NE-51H) 110-125V. AC		FOR B1A (NE-51) 105-125V. AC-DC	
		CATALOG NO. WITH SCREW TERMINALS	CATALOG NO. WITH SOLDER TERMINALS	CATALOG NO. WITH SCREW TERMINALS	CATALOG NO. WITH SOLDER TERMINALS
STOVEPIPE (Screw-in)	Internal Fluting	52-1363-0991-311	52-0463-0991-311	52-1308-0991-341	52-0408-0991-341
STOVEPIPE (Screw-in)	Special Internal Fluting	132-1363-0991-311	132-0463-0991-311	132-1308-0991-341	132-0408-0991-341
CYLINDRICAL (Screw-in)	Transparent	135-1363-1431-311	135-0463-1431-311	135-1308-1431-341	135-0408-1431-341
FLAT (Screw-in)	Transparent	81-1363-0331-311	81-0463-0331-311	81-1308-0331-341	81-0408-0331-341
STOVEPIPE (Screw-in)	Transparent	95-1363-0931-311	95-0463-0931-311	95-1308-0931-341	95-0408-0931-341
DOME (Screw-on)	Transparent+	85-1363-1231-311	85-0463-1231-311	85-1308-1231-341	85-0408-1231-341
	Matted Back	85-1363-0841-311	85-0463-0841-311	85-1308-0841-341	85-0408-0841-341
STOVEPIPE (Screw-on)	Internal Fluting+	169-1363-1191-311	169-0463-1191-311	169-1308-1191-341	169-0408-1191-341
	Transparent+	169-1363-1131-311	169-0463-1131-311	169-1308-1131-341	169-0408-1131-341
STOVEPIPE (Screw-in)	Transparent+	26-1363-1131-311	26-0463-1131-311	26-1308-1131-341	26-0408-1131-341
	Internal Fluting+	26-1363-1191-311	26-0463-1191-311	26-1308-1191-341	26-0408-1191-341



B1A (NE-51)
B2A (NE-51H)

See recommended resistance values on facing page

To designate an assembly with Quick Connect Terminals to accommodate the B2A (NE-51H) lamp, change so much of the catalog number that reads -1363- or -0463- to -5763-; for assemblies to accommodate the B1A (NE-51) lamp, change from -1308- or -0408- to -5708-.

Examples: 95-5763-0931-311; 26-5708-1191-341.

LENS HOLDER AND PLASTIC LENS STYLE	LENS FINISH	FOR B2A (NE-51H) 210-250V. AC-DC		
		CATALOG NO. WITH SCREW TERMINALS	CATALOG NO. WITH SOLDER TERMINALS	CATALOG NO. WITH QUICK CONNECT TERMINALS
STOVEPIPE (Screw-in)	Internal Fluting	52-9363-0991-361	52-9463-0991-361	52-5863-0991-361
STOVEPIPE (Screw-in)	Special Internal Fluting	132-9363-0991-361	132-9463-0991-361	132-5863-0991-361
CYLINDRICAL (Screw-in)	Transparent	135-9363-1431-361	135-9463-1431-361	135-5863-1431-361
FLAT (Screw-in)	Transparent	81-9363-0331-361	81-9463-0331-361	81-5863-0331-361
STOVEPIPE (Screw-in)	Transparent	95-9363-0931-361	95-9463-0931-361	95-5863-0931-361
DOME (Screw-on)	Transparent+	85-9363-1231-361	85-9463-1231-361	85-5863-1231-361
	Matted Back	85-9363-0841-361	85-9463-0841-361	85-5863-0841-361
STOVEPIPE (Screw-on)	Internal Fluting+	169-9363-1191-361	169-9463-1191-361	169-5863-1191-361
	Transparent+	169-9363-1131-361	169-9463-1131-361	169-5863-1131-361
STOVEPIPE (Screw-in)	Transparent+	26-9363-1131-361	26-9463-1131-361	26-5863-1131-361
	Internal Fluting+	26-9363-1191-361	26-9463-1191-361	26-5863-1191-361

HOW TO DESIGNATE THE THREE DIGIT CATALOG NUMBER SUFFIX (-XXX)

FINISH	RESISTOR	HARDWARE
-1 white nickel	1 - 22K	1 - brass
-2 black nickel	2 - 27K	3 - water-tight on the face of the panel.
-3 polished chrome	3 - 33K	
-4 satin chrome	4 - 56K	
	6 - 68K	
	7 - 100K	

NOTE: The part numbers given in this catalog indicate standard indicator lights. The above table provides the standard and optional designations for Finish, Resistor and Hardware where appropriate. Example: 85-1308-1231-273 (black nickel finish, 100K resistor, water-tight construction).

WATER-TIGHT CONSTRUCTION: The assemblies on this page may be made water-tight on the face of the panel. To specify, change the last digit in the catalog number suffix to 3. Example: 95-1308-0931-343.

+See footnote under "Lens Color" on page 5.

Flat faced lens caps can be supplied with legends in positive or negative style on the face of the lens. See Legend Standards on page 8.

PER MIL-L-3661B

LENS TYPE DESIGNATION	LENS SHAPE	WITH LH76/1	WITH LH76/2
		INDICATOR LIGHT HOUSING	INDICATOR LIGHT HOUSING
LC14	Convex	373-0408-0131-273	373-0463-0131-223
LC17	Convex, Mech. Dimmer	375-0408-0131-273	375-0463-0131-223
	Complete Blackout		
LC18	Convex, Mech. Dimmer Semi-Blackout	376-0408-0131-273	376-0463-0131-223



LENS TYPE DESIGNATION	LENS SHAPE	WITH LH77/1	WITH LH77/2
		INDICATOR LIGHT HOUSING	INDICATOR LIGHT HOUSING
LC19	Stovepipe (transparent)	377-0408-1131-273	377-0463-1131-223
LC20	Stovepipe (internally fluted)	377-0408-1191-273	377-0463-1191-223

LENS COLOR—To designate lens color, see description on page 5.



INDICATOR LIGHTS with BUILT-IN RESISTOR FOR T-3 1/4 NEON GLOW LAMPS B2A (NE-51H) & B1A (NE-51)

For Rear Mounting in 9/16" Clearance Hole

When Connecting a Neon Light to a Circuit Having One Side Grounded, Always Connect the Hot Side of the Circuit to the Terminal Marked + (Center Contact).



See recommended resistance values on Page 2.

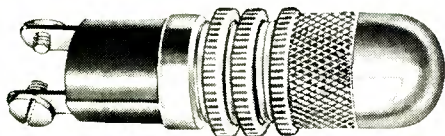

17-1363-0931-215
Stovepipe Transparent lens

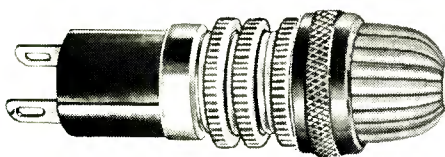

70-0463-1191-215
Stovepipe Internally Fluted lens

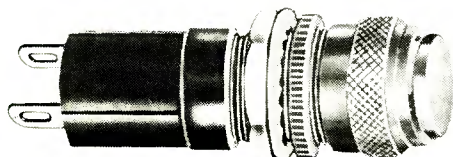

37-0408-0331-246
Flat lens with optional hardware (illus.)

37-0408-0331-245
With standard hardware (not illus.)

Recognized under the component program of Underwriters' Laboratories Inc.

75W., 125V.
75W., 250V.

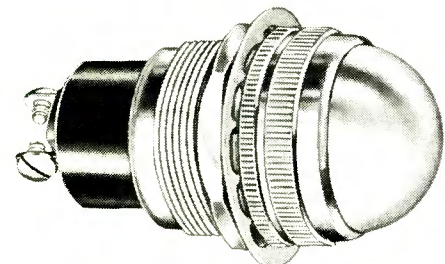

80-1363-1231-311
Dome lens

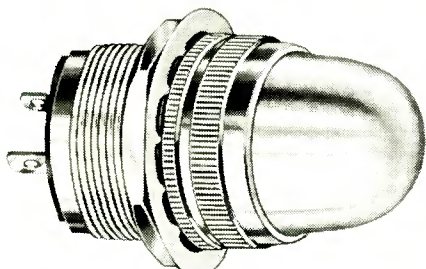

80-0463-0931-311
Stovepipe lens

MATERIALS AND FINISHES

- **Mounting Bushing:** Standard—Brass, black nickel finish, Optional—White nickel finish.
- **Lens Holder:** Standard—Brass, black nickel finish, Optional—Polished or satin chrome finish.
- **Standard Hardware:** Three (3) knurled rings—Brass, black nickel finish. **Optional Hardware:** one (1) knurled ring—Brass, black nickel finish; one (1) mounting nut—Brass, white nickel finish; one (1) internal-tooth lockwasher—Steel, cadmium plated with yellow iridescent chromate finish.
- **Terminals:** **Soldering**—Brass, hot tinned with elongated slot. **Screw**—Brass, white nickel finish.

Note: Where optional metal finish is chosen for lens holder, the same finish will be supplied for knurled ring(s).

WITH SCREW-ON LENS CAPS

PLASTIC LENS STYLE	LENS FINISH	FOR B2A (NE-51H) 110-125V. AC		FOR B1A (NE-51) 105-125V. AC-DC	
		CATALOG NO. WITH SCREW TERMINALS	CATALOG NO. WITH SOLDER TERMINALS	CATALOG NO. WITH SCREW TERMINALS	CATALOG NO. WITH SOLDER TERMINALS
STOVEPIPE	Transparent	17-1363-0931-215	17-0463-0931-215	17-1308-0931-245	17-0408-0931-245
	Internal Fluting	17-1363-0991-215	17-0463-0991-215	17-1308-0991-245	17-0408-0991-245
STOVEPIPE	Transparent+	70-1363-1131-215	70-0463-1131-215	70-1308-1131-245	70-0408-1131-245
	Internal Fluting+	70-1363-1191-215	70-0463-1191-215	70-1308-1191-245	70-0408-1191-245
FLAT	Transparent	37-1363-0331-215	37-0463-0331-215	37-1308-0331-245	37-0408-0331-245

The catalog number suffix designates an assembly with standard Black Nickel finish. To specify optional finish, change first digit of the catalog number suffix to -3 (polished chrome finish), or -4 (satin chrome finish). Example: 17-1308-0931-345.

To designate an assembly with "optional hardware" (see Materials and Finishes above), change last digit in the catalog number suffix to 6. Example: 37-0408-0331-246.



506-0562 WRENCH

The threaded round knurled nuts used on these indicator lights have a precise knurl of these specifications: 64 D.P. ST. Knurl, Class III. For your convenience, Dialco 506-0562 Wrench can be furnished to permit secure fastening of indicators on mounting panels.

For Mounting in 1" Clearance Hole

MATERIALS AND FINISHES

- **Mounting Bushing:** Standard—Brass, white nickel finish, Optional—Black nickel finish.
- **Lens Holder and Knurled Flange Ring:** Standard—Brass, polished chrome finish, Optional—Black nickel or satin chrome finish.
- **Mounting Nut:** Brass, white nickel finish.
- **Internal-tooth Lockwasher:** Phosphor bronze, white nickel finish.
- **Terminals:** **Soldering**—Brass, hot tinned with elongated slot. **Screw**—Brass, white nickel finish.

WITH SCREW-ON LENS CAPS

PLASTIC LENS STYLE	LENS FINISH	FOR B2A (NE-51H) 110-125V. AC		FOR B1A (NE-51) 105-125V. AC-DC	
		CATALOG NO. WITH SCREW TERMINALS	CATALOG NO. WITH SOLDER TERMINALS	CATALOG NO. WITH SCREW TERMINALS	CATALOG NO. WITH SOLDER TERMINALS
DOME	Transparent+	80-1363-1231-311	80-0463-1231-311	80-1308-1231-341	80-0408-1231-341
	Matted Back	80-1363-0841-311	80-0463-0841-311	80-1308-0841-341	80-0408-0841-341
STOVEPIPE	Transparent	80-1363-0931-311	80-0463-0931-311	80-1308-0931-341	80-0408-0931-341
	Matted Back	80-1363-0941-311	80-0463-0941-311	80-1308-0941-341	80-0408-0941-341

The Catalog number suffix designates an assembly with standard Polished Chrome finish. To specify optional finish, change the first digit of the catalog number suffix to -2 (black nickel finish) or -4 (satin chrome finish). Examples: 80-0408-0931-441 (see table above); 80-9463-1231-261 (see table below).

WITH SCREW-ON LENS CAPS

PLASTIC LENS STYLE	LENS FINISH	FOR B2A (NE-51H) 210-250V. AC-DC	
		CATALOG NO. WITH SCREW TERMINALS	CATALOG NO. WITH SOLDER TERMINALS
DOME	Transparent+	80-9363-1231-361	80-9463-1231-361
	Matted Back	80-9363-0841-361	80-9463-0841-361
STOVEPIPE	Transparent	80-9363-0931-361	80-9463-0931-361
	Matted Back	80-9363-0941-361	80-9463-0941-361

Note: These assemblies are also available with 31 (friction-fit) and 51 (screw-on) Series Lens Caps. Please contact the factory for data and ordering information.

WATER-TIGHT CONSTRUCTION: The assemblies on this page may be made water-tight on the face of the panel. To specify, change the last digit in the catalog number suffix to 3. Example: 80-0408-1231-343.

+See footnote under "Lens Color" on Page 5.

LENS COLOR: See description on facing page.

INDICATOR LIGHTS for T-4-1/2 NEON GLOW LAMPS with CANDELABRA SCREW BASE



For Mounting in 1" Clearance Hole

These series indicator lights meet or exceed requirements of MIL-L-3661.

Types B7A (NE-45) and F4A (NE-58) Neon Glow Lamps with Candelabra screw base contain the resistor in the lamp base, and are suitable for operation on 105-125V and 210-250V respectively.

B7A (NE-45)
For 105-125V

F4A (NE-58)
For 210-250V



MATERIALS AND FINISHES

- **Mounting Bushing:** Standard—Brass, white nickel finish. Optional—Black nickel finish.
- **Lens Holder and Knurled Flange Ring:** Brass, polished chrome finish. Optional—Black nickel or satin chrome finish.
- **Mounting Nut:** Brass, white nickel finish.
- **Internal-tooth Lockwasher:** Phosphor bronze, white nickel finish.
- **Terminals:** Soldering—Brass, hot tinned.
Screw—Brass, white nickel finish.
Quick Connect—Brass, tinned. Mate with standard female receptacles.

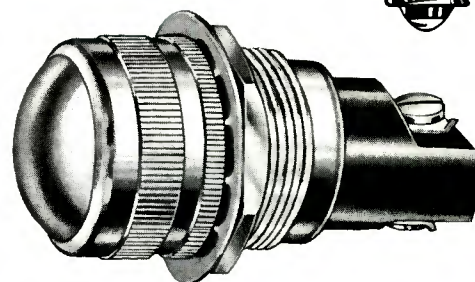

51-0914-0111-301
Convex lens

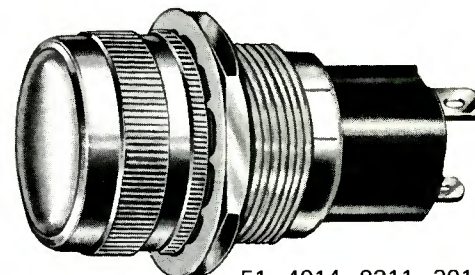

51-4014-0211-301
Flat lens

WITH SCREW-ON LENS CAPS

LENS STYLE	LENS FINISH	CATALOG NO. WITH SCREW TERMINALS (SIDE POS.)	CATALOG NO. WITH SCREW TERMINALS (PROTRUDING POS.)	CATALOG NO. WITH SOLDERING TERMINALS	CATALOG NO. WITH QUICK CONNECT TERMINALS
DOME	Transparent+	80-0914-1231-301	80-3114-1231-301	80-4014-1231-301	80-6714-1231-301
	Matted Back	80-0914-0841-301	80-3114-0841-301	80-4014-0841-301	80-6714-0841-301
STOVEPIPE	Transparent	80-0914-0931-301	80-3114-0931-301	80-4014-0931-301	80-6714-0931-301
	Matted Back	80-0914-0941-301	80-3114-0941-301	80-4014-0941-301	80-6714-0941-301
CONVEX	Transparent	51-0914-0131-301	51-3114-0131-301	51-4014-0131-301	51-6714-0131-301
	Back Frosted	51-0914-0111-301	51-3114-0111-301	51-4014-0111-301	51-6714-0111-301
FLAT	Transparent	51-0914-0231-301	51-3114-0231-301	51-4014-0231-301	51-6714-0231-301
	Back Frosted	51-0914-0211-301	51-3114-0211-301	51-4014-0211-301	51-6714-0211-301

Recognized under the component program of Underwriters' Laboratories Inc.

75W., 125V.



The catalog number suffix designates an assembly with standard Polished Chrome finish. To specify optional finish, change the first digit of the catalog number suffix to -2 (black nickel finish) or -4 (satin chrome finish). Example: 80-3114-1231-201.

Note: These assemblies are also available with 31 Series friction-fit lens caps. Please contact the factory for data and ordering information.

WATER-TIGHT CONSTRUCTION: The assemblies on this page may be made water-tight on the face of the panel. To specify, change the last digit in the catalog number suffix to 3. Example: 51-3114-0131-303.

LENS COLOR: The last digit before the 3 digit catalog number suffix indicates that the lens is RED. When color other than red is desired, change this digit to a figure from the listing below. Note: White lenses are translucent and are always furnished unfrosted.

Red-1; Yellow (Amber)-3; White Translucent-5; Light Yellow-6; Clear (Colorless)-7.

+ To specify white translucent color, change so much of the catalog number that reads -1231- to -0835-; from -1131- to -0935-; from -1191- to -0995-. Examples: 169-1363-0935-311; 80-0914-0835-301.

ORDER COMPLETE WITH LAMP so that you will be assured of receiving the indicator light and correct lamp at one time for immediate use.

SAMPLES ON REQUEST AT ONCE - NO CHARGE

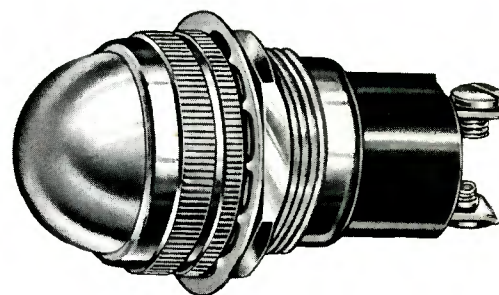

80-3114-1231-301
Dome lens

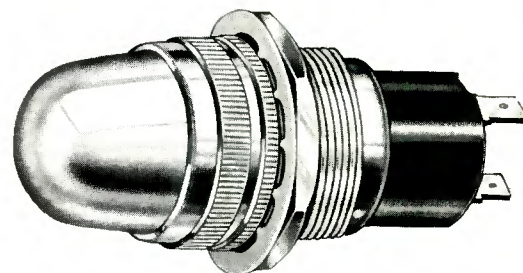

80-6714-0931-301
Stovepipe lens



(All illustrations are approx. actual size)

INDICATOR LIGHTS for T-2 BULB with TELEPHONE SLIDE BASE INCANDESCENT - 6 TO 60 VOLTS

For mounting in 9/16" Clearance Hole



See lamp ratings on facing page

MATERIALS AND FINISHES

- **Mounting Bushing:** Standard—White nickel finish. Optional—black nickel finish.
- **Lens Holder:** Standard—Polished chrome finish. Optional—white nickel, black nickel or satin chrome finish.
- **Standard Hardware:** Three (3) knurled rings—one brass, polished chrome finish; two rings brass, white nickel finish. **Optional Hardware**—One mounting nut—brass, white nickel finish. One knurled ring—brass, polished chrome finish. One internal-tooth lockwasher—steel, cadmium plated with yellow iridescent chromate finish.
- **Terminals:** Soldering—Brass, hot tinned. Screw—Brass, white nickel finish.

Note: Where optional metal finish is chosen for lens holder, the same finish will be supplied for knurled ring(s).

INDICATORS WITH SCREW-ON CAPS

LENS TYPE	LENS FINISH	CAT. NO. WITH SCREW TERMINALS	CAT. NO. WITH SOLDERING TERMINALS
STOVEPIPE	Transparent	17-1328-0931-305	17-0428-0931-305
	Inside Fluted	17-1328-0991-305	17-0428-0991-305
STOVEPIPE	Unfrosted	70-1328-1131-305	70-0428-1131-305
	Back Frosted	70-1328-1111-305	70-0428-1111-305
	Inside Fluted	70-1328-1191-305	70-0428-1191-305
CONVEX	Unfrosted	37-1328-0131-305	37-0428-0131-305
	Back Frosted	37-1328-0111-305	37-0428-0111-305
FACETED	Unfrosted	37-1328-0431-305	37-0428-0431-305

INDICATORS WITH FRICTION-FIT CAPS

LENS TYPE	LENS FINISH	CAT. NO. WITH SCREW TERMINALS	CAT. NO. WITH SOLDERING TERMINALS
FLAT	Unfrosted	33-1328-0231-305	33-0428-0231-305
	Back Frosted	33-1328-0211-305	33-0428-0211-305
FLAT+	Transparent	33-1328-0331-305	33-0428-0331-305
	Translucent	33-1328-0351-305	33-0428-0351-305

- Specify translucent colors as follows: Red—0351 . . . Green—0352 . . . Yellow (Amber)—0373 . . . White—0375 . . . Light Yellow—0376.
- + See footnote on facing page.

HOW TO DESIGNATE THE THREE DIGIT CATALOG NUMBER SUFFIX (-XXX)

FINISH	RESISTOR	HARDWARE
-1 white nickel	0—none	5—three knurled rings
-2 black nickel		6—knurled ring,
-3 polished chrome		internal-tooth
-4 satin chrome		lockwasher, mtg. nut

Note: The part numbers listed on this page indicate standard indicator lights. The above table provides the standard and optional designations for Finish and Hardware. Examples: 37-1328-0131-205; 33-0428-0351-106.

Flat faced lens caps can be supplied with legends in positive or negative style on the face of the lens. See Legend Standards on page 8.

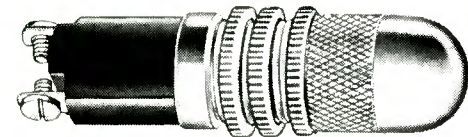

17-1328-0931-305 Stovepipe lens

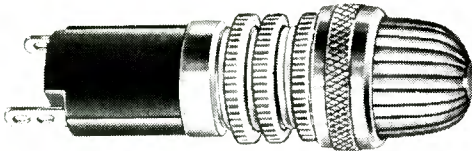

70-0428-1191-305 Stovepipe lens

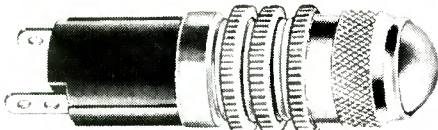

37-0428-0111-305 Convex lens

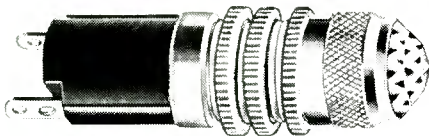

37-0428-0431-305 Faceted lens

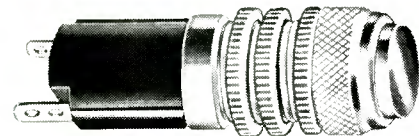

33-0428-0351-305 Flat lens
33-0428-0211-305

TYPICAL ASSEMBLY WITH OPTIONAL HARDWARE

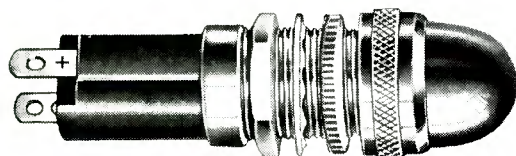

70-0428-1131-306 Stovepipe lens

LENS COLOR: The last digit before the three digit catalog number suffix indicates that the lens is RED. When a color other than red is desired, change this digit to a figure from the listing below. Note that white lenses are translucent and are always furnished unfrosted.

- Red—1; Green—2; Yellow (Amber)—3; Blue—4;
- White (Translucent)—5; Light Yellow—6;
- Clear (Colorless)—7.

Lampholders for Panel Mounting

Requires 7/16" Mounting Clearance Hole
(Maximum outside diameter—1/2")



105-4428-0731-200



220-0111-100

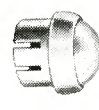

129-0111-200



126-0351-200

These open type Lampholders are most suitable for indication, warning, and signal applications requiring T-2 Lamps as the light source. See ordering information on facing page.

SIZE OF TYPE FOR LEGENDS

Number of Characters	Character Height
ONE	.203
TWO	.171
THREE	.141
FOUR	.078

INDICATOR LIGHTS for T-2 BULB with TELEPHONE SLIDE BASE INCANDESCENT -6 TO 60 VOLTS

(All illustrations are approx. actual size)



For mounting in 11/16" Clearance Hole

MATERIALS AND FINISHES

- **Mounting Bushing and Lens Holder:** Standard—Polished chrome finish. Optional—white nickel, black nickel or satin chrome finish.
- **Mounting Nut:** Brass, white nickel finish.
- **Internal-tooth Lockwasher:** Phosphor bronze, white nickel finish.
- **Terminals:** Soldering—Brass, hot tinned.
Screw—Brass, white nickel finish.

LAMP NO.	VOLTS	AMPS	HOURS	LAMP NO.	VOLTS	AMPS	HOURS
6A	6	.12-.16	5,000+	24E	24	.032-.038	5,000+
6B	6	.27-.31	5,000+	24X	24	.032-.038	5,000+
6C	6	.035-.045	5,000+	30A	30	.06-.085	5,000+
8A	8	.08-10	5,000+	30B	30	.09-.11	5,000+
10A	10	.10-12	5,000+	35A	35	.035-.045	5,000+
12A	12	.09-11	5,000+	48A	48	.06-.085	5,000+
12B	12	.032-.038	5,000+	48B	48	.09-.11	5,000+
16A	16	.09-11	5,000+	48C	48	.032-.038	5,000+
18B	18	.09-11	5,000+	48D	48	.017-.025	5,000+
24A	24	.025-.035	5,000+	55B	55	.09-.11	5,000+
24B	24	.035-.045	5,000+	55C	55	.045-.06	5,000+
24C	24	.06-.085	5,000+	60A	60	.045-.055	5,000+
24D	24	.09-.11	5,000+	No higher voltages available.			



INDICATORS WITH SCREW-IN CAPS

LENS TYPE	LENS FINISH	CAT. NO. WITH SCREW TERMINALS	CAT. NO. WITH SOLDERING TERMINALS
STOVEPIPE	Transparent	95-1328-0931-301	95-0428-0931-301
	Translucent	95-1328-0971-301	95-0428-0971-301
CONVEX	Unfrosted	81-1328-0131-301	81-0428-0131-301
	Back Frosted	81-1328-0111-301	81-0428-0111-301
FACETED	Unfrosted	81-1328-0431-301	81-0428-0431-301
CYLINDRICAL+	Transparent	135-1328-1431-301	135-0428-1431-301
	Translucent	135-1328-1471-301	135-0428-1471-301
	Unfrosted	26-1328-1131-301	26-0428-1131-301
STOVEPIPE	Back Frosted	26-1328-1111-301	26-0428-1111-301
	Inside Fluted	26-1328-1191-301	26-0428-1191-301

Ratings of lamps are taken from published catalogs of leading lamp manufacturers.

INDICATORS WITH FRICTION-FIT CAPS

LENS TYPE	LENS FINISH	CAT. NO. WITH SCREW TERMINALS	CAT. NO. WITH SOLDERING TERMINALS
FLAT	Unfrosted	55-1328-0231-301	55-0428-0231-301
	Back Frosted	55-1328-0211-301	55-0428-0211-301
FLAT+	Transparent	55-1328-0331-301	55-0428-0331-301
	Translucent	55-1328-0351-301	55-0428-0351-301

■ Specify translucent colors as follows: Red-0351 . . . Green-0352 . . . Yellow (Amber)-0373 . . . White-0375 . . . Light Yellow-0376.

+ Legends: Specify this series if it is desired to have hot-stamped or engraved legends. See "Size of Type for Legends on page 8 . . ."

LENS COLOR: See description on page 8.

Flat faced lens caps can be supplied with legends in positive or negative style on the face of the lens. See Legend Standards on page 8.

HOW TO DESIGNATE THE THREE DIGIT CATALOG NUMBER SUFFIX (-XXX)

FINISH	RESISTOR	HARDWARE
-1 white nickel	0—none	1—brass
-2 black nickel		3—water-tight on the face of the panel
-3 polished chrome		
-4 satin chrome		

Note: The part numbers listed on this page indicate standard indicator lights. The above table provides the standard and optional designations for Finish and Hardware. Example: 81-0428-0111-203.

WATER-TIGHT CONSTRUCTION: Indicators with Screw-in Caps may be made water-tight on the face of the panel. To specify, change the last digit in the catalog number. Example: 26-0428-1191-303.

SEE LAMP HOLDERS FOR PANEL MOUNTING ON FACING PAGE

LENS TYPE	LENS DIAM.	LENS FINISH	CAT. NO. WITH SOLDERING TERMINALS	PROJECTION		C. TO C. SPACING*
				Front	Back	
CONVEX	1/2"	Unfrosted	220-4428-0131-100	5/16"	2-19/32"	9/16"
		Back Frosted	220-4428-0111-100	5/16"	2-19/32"	9/16"
CONVEX	11/32"	Unfrosted	129-4428-0131-200	1/4"	2-19/32"	9/16"
		Back Frosted	129-4428-0111-200	1/4"	2-19/32"	9/16"
PLANO CONVEX	11/32"	Unfrosted	105-4428-0731-200	1/4"	2-19/32"	9/16"
FLAT	13/32"	Translucent	126-4428-0351-200	1/4"	2-19/32"	9/16"

■ Specify translucent colors as follows: Red-0351 . . . Green-0352 . . . Yellow (Amber)-0373 . . . White-0375 . . . Light Yellow-0376. *Maximum O.D. of each unit 1/2".

FINISHES: 220 Series: Standard—White nickel. Optional—Black nickel or polished chrome. 105, 126 and 129 Series: Standard—Black nickel. Optional—White nickel or polished chrome. To designate the appropriate optional finish, see above chart "HOW TO DESIGNATE THE THREE DIGIT CATALOG NUMBER SUFFIX (-XXX)".

NOTE: It is necessary to use an extractor to insert or remove lamp.

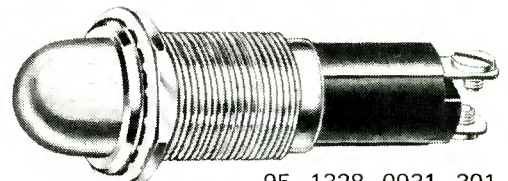

Stovepipe lens

95-1328-0931-301

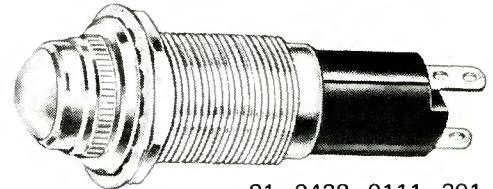

Convex lens

81-0428-0111-301

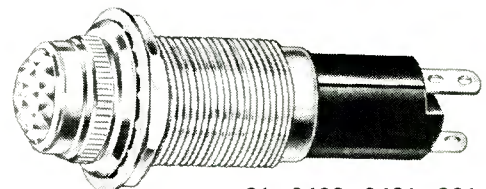

Faceted lens

81-0428-0431-301

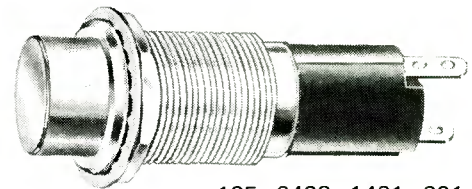

Cylindrical lens

135-0428-1431-301

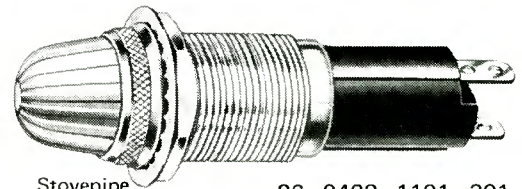

Stovepipe Inside Fluted lens

26-0428-1191-301

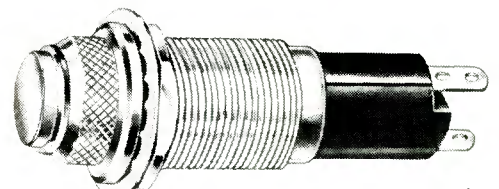

Flat lens

55-0428-0351-301
55-0428-0211-301



INDICATOR LIGHTS for T-3 1/4 BULB with MINIATURE BAYONET BASE

(All illustrations are approx. actual size)

INCANDESCENT - 2 TO 120 VOLTS*

For Mounting in 11/16" Clearance Hole

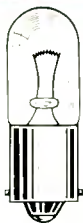

These series indicator lights meet or exceed requirements of MIL-L-3661.

*The assemblies on this and the facing page also accommodate T-3 bulbs with miniature bayonet base, incandescent—in voltages from 6–120V. When lamps rated 2 watts or over are used, lens caps of high temperature plastic are required. Contact the factory for additional data and correct catalog number designations.

MATERIALS AND FINISHES

- **Mounting Bushing and Lens Holder:** Standard—Brass, polished chrome. Optional—White nickel, black nickel or satin chrome finish.
- **Mounting Nut:** Brass, white nickel finish.
- **Internal-tooth Lockwasher:** Phosphor bronze, white nickel finish.
- **Terminals: Soldering—**Brass, hot tinned with elongated slot.
Screw—Brass, white nickel finish.
Quick Connect—Brass, tinned. Mate with standard female receptacles.

LAMP NO.	VOLTS	AMPS	WATTS	C.P.	HOURS
49	2.0	0.06	0.12	0.04	1,000
45	3.2	0.35	1.12	0.50	3,000
47	6.3	0.15	0.95	0.52	3,000
1847	6.3	0.15	0.95	0.38	3,000
44	6.3	0.25	1.6	0.90	3,000
1866	6.3	0.25	1.6	0.65	20,000
755	6.3	0.15	0.95	0.33	20,000
1891*	14.0	0.24	3.4	2.0	500
1815*	14.0	0.20	2.8	1.4	3,000
756	14.0	0.08	1.1	0.31	15,000
1819	28.0	0.04	1.1	0.34	1,000
1829	28.0	0.07	1.9	1.0	1,000
1820*	28.0	0.10	2.8	1.6	1,000
313*	28.0	0.17	4.7	3.5	500
757*	28.0	0.08	2.3	0.62	7,500
1828	37.5	0.05	1.9	0.65	20,000
1835*	55.0	0.05	2.8	1.1	20,000

C.P. is approximate mean spherical candlepower.
*These lamps, of 2 watts or more, should be used only in Indicator Lights designed for high temperature operation.

Ratings of lamps are taken from published catalogs of leading lamp manufacturers.

Recognized under the component program of Underwriters' Laboratories Inc.

75W., 125V.



LENS STYLE	LENS FINISH	CATALOG NO. WITH SCREW TERMINALS	CATALOG NO. WITH SOLDER TERMINALS	CATALOG NO. WITH QUICK CONNECT TERMINALS
STOVEPIPE	Transparent	95-1310-0931-301	95-0410-0931-301	95-5710-0931-301
	Translucent	95-1310-0971-301	95-0410-0971-301	95-5710-0971-301
STOVEPIPE	Internal Fluting	52-1310-0991-301	52-0410-0991-301	52-5710-0991-301
STOVEPIPE	Special Internal Fluting	132-1310-0991-301	132-0410-0991-301	132-5710-0991-301
	Translucent	135-1310-1431-301	135-0410-1431-301	135-5710-1431-301
CYLINDRICAL▲	Transparent	135-1310-1471-301	135-0410-1471-301	135-5710-1471-301
	Translucent	135-1310-1471-301	135-0410-1471-301	135-5710-1471-301
CONVEX*	Unfrosted	81-1310-0131-301	81-0410-0131-301	81-5710-0131-301
	Back Frosted	81-1310-0111-301	81-0410-0111-301	81-5710-0111-301
FLAT*	Back Frosted	81-1310-0211-301	81-0410-0211-301	81-5710-0211-301
	Unfrosted	81-1310-0231-301	81-0410-0231-301	81-5710-0231-301
FLAT▲	Transparent	81-1310-0351-301	81-0410-0351-301	81-5710-0351-301
	Translucent	81-1310-0331-301	81-0410-0331-301	81-5710-0331-301
STOVEPIPE*	Unfrosted	26-1310-1131-301	26-0410-1131-301	26-5710-1131-301
	Back Frosted	26-1310-1111-301	26-0410-1111-301	26-5710-1111-301
	Internal Fluting	26-1310-1191-301	26-0410-1191-301	26-5710-1191-301
STOVEPIPE*	Transparent	169-1310-1131-301	169-0410-1131-301	169-5710-1131-301
	Internal Fluting	169-1310-1191-301	169-0410-1191-301	169-5710-1191-301
DOME	Transparent	85-1310-1231-301	85-0410-1231-301	85-5710-1231-301
	Matted Back	85-1310-0841-301	85-0410-0841-301	85-5710-0841-301

■ Specify translucent colors as follows: Red-0351; Green-0352; Yellow (Amber)-0373; Blue-0374; White-0375; Light Yellow-0376. Example: 81-1310-0374-301.

* These assemblies should be specified when lamps rated over 2 watts are used. See lamp chart above.

▲ LEGENDS: Hot-stamped or engraved letters, numbers or symbols can be supplied only on these lenses.

HOW TO DESIGNATE THE THREE DIGIT CATALOG NUMBER SUFFIX (-XXX)

FINISH	RESISTOR	HARDWARE
-1 white nickel	0—None	1—brass
-2 black nickel		3—water-tight, on the face of the panel.
-3 polished chrome		
-4 satin chrome		

NOTE: The part numbers given in this catalog indicate standard indicator lights. The table at the left provides the standard and optional designations for Finish and Hardware where appropriate. Example: 95-1310-0931-203 (black nickel finish with water-tight construction).

WATER-TIGHT CONSTRUCTION: The assemblies on this page may be made water-tight on the face of the panel. To specify, change the last digit in the catalog number suffix to 3. Example: 26-0410-1191-303.

SIZE OF TYPE FOR LEGENDS

Number of Characters	Character Height
ONE	.266
TWO	.203
THREE	.141
FOUR	.085

STANDARD: Black letters. White, red, green, blue or silver can be supplied on request. Unless otherwise specified, these standard sizes will be provided in a uniform manner per order—i.e., the size of type will be determined by the largest legend in each individual order.

LENS COLOR: The last digit before the 3 digit catalog number suffix indicates that the lens is RED. When color other than red is desired, change this digit to a figure from the listing below. Note that white lenses are translucent and are always furnished unfrosted.

Red-1; Green-2; Yellow (Amber)-3; Blue-4; White Translucent-5; Light Yellow-6; Clear (Colorless)-7.

ORDER COMPLETE WITH LAMP so that you will be assured of receiving the indicator light and correct lamp at one time for immediate use.

81-0410-0111-301
Screw-in lens cap

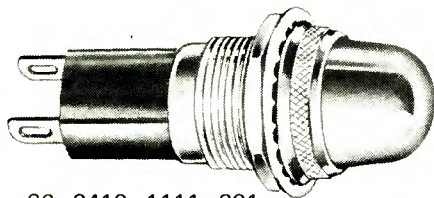

26-0410-1111-301
Screw-in lens cap

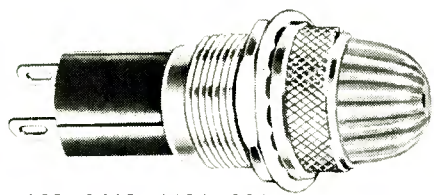

169-0410-1191-301
Screw-on lens cap

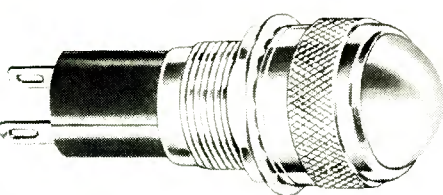

85-0410-1231-301
Screw-on lens cap

Illustrations are approx. actual size)

INDICATOR LIGHTS for T-3 1/4 BULB with MINIATURE BAYONET BASE INCANDESCENT - 2 TO 120 VOLTS*



For Mounting in 11/16" Clearance Hole

See Table of Catalog Numbers on Facing Page

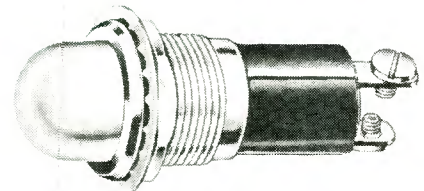

95-1310-0931-301
Screw-in lens cap

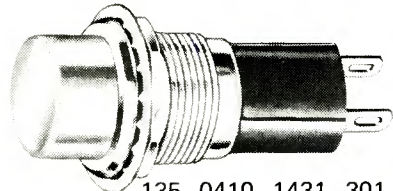

135-0410-1431-301
Screw-in lens cap

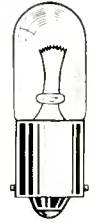

See range of voltages on facing page.

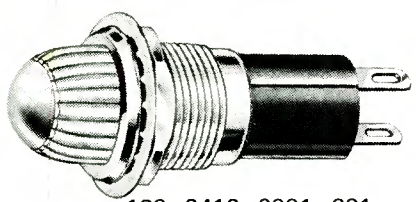

132-0410-0991-301
Screw-in lens cap

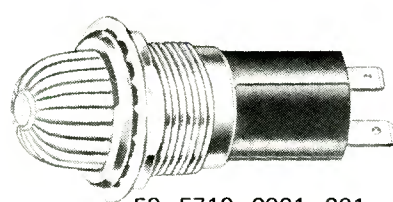

52-5710-0991-301
Screw-in lens cap

Recognized under the component program of Underwriters' Laboratories Inc.
75W., 125V.

PER MIL-L-3661B

LENS TYPE DESIGNATION	LENS SHAPE	WITH LH76/3 INDICATOR LIGHT HOUSING
LC14	Convex	373-0410-0131-203
LC17	Convex, Mech, Dimmer Complete Blackout	375-0410-0131-203
LC18	Convex, Mech, Dimmer Semi-Blackout	376-0410-0131-203

LENS TYPE DESIGNATION	LENS SHAPE	WITH LH77/3 INDICATOR LIGHT HOUSING
LC19	Stovepipe (transparent)	377-0410-1131-203
LC20	Stovepipe (internally fluted)	377-0410-1191-203

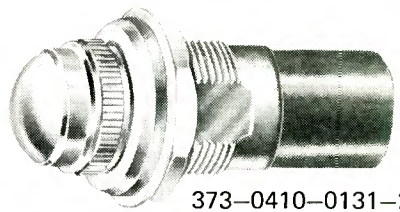

373-0410-0131-203

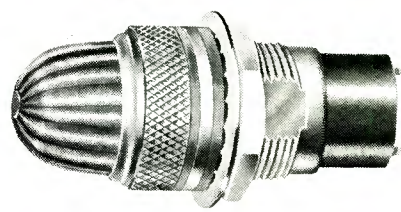

377-0410-1191-203

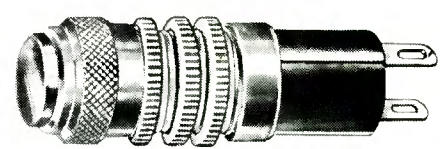

37-0410-0211-205
Flat lens

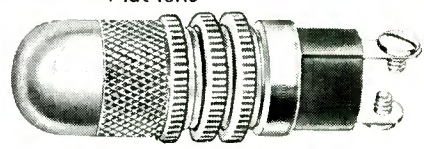

17-1310-0931-205
Stovepipe
Transparent lens

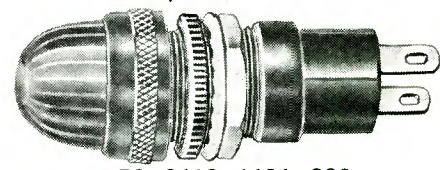

70-0410-1191-206
Stovepipe
Internally Fluted lens
With optional hardware (illus.)

70-0410-1191-205
With standard hardware (not illus.) 9

For Rear Mounting in 9/16" Clearance Hole

MATERIALS AND FINISHES

- **Mounting Bushing:** Standard—Brass, black nickel finish. Optional—White nickel finish.
- **Lens Holder:** Standard—Brass, black nickel finish. Optional—Polished or satin chrome finish.
- **Standard Hardware:** Three (3) knurled rings—Brass, black nickel finish. **Optional Hardware:** One (1) mounting nut—Brass, white nickel finish; one (1) knurled ring—Brass, black nickel finish; one (1) internal-tooth lockwasher—Steel, cadmium plated with yellow iridescent chromate finish.
- **Terminals:** **Soldering**—Brass, hot tinned with elongated slot. **Screw**—Brass, white nickel finish.

Note: Where optional metal finish is chosen for lens holder, the same finish will be supplied for knurled ring(s).

SCREW-ON LENS CAPS

LENS STYLE	LENS FINISH	CATALOG NO. WITH SCREW TERMINALS	CATALOG NO. WITH SOLDER TERMINALS
STOVEPIPE	Transparent	17-1310-0931-205	17-0410-0931-205
	Internal Fluting	17-1310-0991-205	17-0410-0991-205
FLAT	Back Frosted	37-1310-0211-205	37-0410-0211-205
	Transparent	70-1310-1131-205	70-0410-1131-205
STOVEPIPE	Internal Fluting	70-1310-1191-205	70-0410-1191-205
	Back Frosted	70-1310-1111-205	70-0410-1111-205

NOTE: The catalog number suffix designates an assembly with standard Black Nickel finish. To specify optional finish, change the first digit of the catalog number suffix to -3 (polished chrome finish) or -4 (satin chrome finish). Example: 17-1310-0931-401. To designate an assembly with "optional hardware" (see Materials and Finishes above), change last digit in the catalog number to 6. Example: 37-0410-0211-206.

WRENCH: SEE PAGE 4.

LENS COLOR: See description on facing page.



INDICATOR LIGHTS for T-2 BULB with TELEPHONE SLIDE BASE INCANDESCENT-6 TO 120 VOLTS

For Mounting in 11/16" Clearance Hole

T-2 BULBS WITH TELEPHONE SLIDE BASE

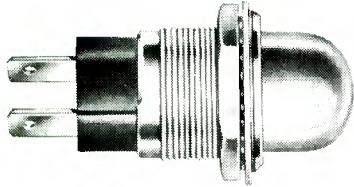

95-1059-3171-102

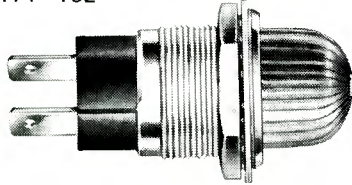

52-1059-3191-102

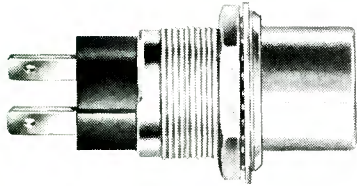

135-1059-3271-102

LAMP NO.	VOLTS	AVG. WATTS	AVG. CURRENT (AMPS)	LAMP LIFE** (HOURS)
6PSB	6	.8	.140	5000+
12PSB	12	2.0	.170	5000+
24PSB	24	1.7	.073	5000+
28PSB	28	1.1	.040	5000+
48PSB	48	2.5	.053	5000+
60PSB	60	3.0	.050	5000+
120PSB	120	3.0	.025	5000+

**Based on the lamp manufacturer's statement: "Engineered to give a minimum of 5000 hours under static conditions." Lamps giving this performance are comparable with those rated at 25,000 hours "average" life.

Ratings of lamps are taken from published catalogs of leading lamp manufacturers.



MATERIALS AND FINISHES

- **Mounting Bushing and Lens Holder:** Brass, white nickel finish. Optional—Polished chrome.
- **Mounting Nut:** Steel, cadmium plated with yellow iridescent chromate finish.
- **Internal-tooth Lockwasher:** Steel, cadmium plated with yellow iridescent chromate finish.
- **Terminals:** Amp Connector No. 42198-2. Brass, white nickel finish. Leads may be soldered through holes provided in the contacts.
- **Lens Cap:** (52-, 95-, 135- Series)—High temperature plastic.

SCREW-IN LENS CAPS

LENS COLOR	COMPLETE ASSEMBLIES			LENS CAP ASSEMBLIES		
	STOVEPIPE LENS TRANSLUCENT	STOVEPIPE LENS INTERNALLY FLUTED	CYLINDRICAL LENS TRANSLUCENT*	STOV'P. TRANS'L.	STOV'P. FLUTED	CYL. TRANS'L.*
Red	95-1059-3171-102	52-1059-3191-102	135-1059-3271-102	95-3171	52-3191	135-3271
Green	95-1059-3172-102	52-1059-3192-102	135-1059-3272-102	95-3172	52-3192	135-3272
Yellow (Amber)	95-1059-3173-102	52-1059-3193-102	135-1059-3273-102	95-3173	52-3193	135-3273
Blue	95-1059-3174-102	52-1059-3194-102	135-1059-3274-102	95-3174	52-3194	135-3274
White	95-1059-3175-102	52-1059-3195-102	135-1059-3275-102	95-3175	52-3195	135-3275
Light Yellow	95-1059-3176-102	52-1059-3196-102	135-1059-3276-102	95-3176	52-3196	135-3276
Clear (Colorless)	-----	52-1059-3197-102	-----	-----	52-3197	-----
Base Assembly	81-1059-01-102					

* Recommended for use with hot-stamped legends

Note: To specify optional polished chrome finish, change the first digit of the catalog number suffix from "1" to "3".
Example: 135-1059-3273-302.

SCREW-IN LENS CAPS

LENS COLOR	COMPLETE ASSEMBLIES		LENS CAP ASSEMBLIES	
	CONVEX LENS BACK FROSTED	FACETED LENS UNFROSTED	CONVEX BACK FROSTED	FACETED UNFROSTED
Red	81-1059-0111-102	81-1059-0431-102	81-0111-100	81-0431-100
Green	81-1059-0112-102	81-1059-0432-102	81-0112-100	81-0432-100
Yellow (Amber)	81-1059-0113-102	81-1059-0433-102	81-0113-100	81-0433-100
Blue	81-1059-0114-102	81-1059-0434-102	81-0114-100	81-0434-100
White	81-1059-0135-102+	81-1059-0435-102	81-0135-100+	81-0435-100
Light Yellow	81-1059-0116-102	81-1059-0436-102	81-0116-100	81-0436-100
Clear (Colorless)	81-1059-0117-102	81-1059-0437-102	81-0117-100	81-0437-100
Base Assembly	81-1059-01-102			

+ Unfrosted

Note: To specify optional polished chrome finish, change the first digit of the catalog number suffix from "1" to "3". Examples: 81-1059-0111-302 (complete assembly); 81-0432-300 (lens cap assembly).

LEGEND STANDARDS:
See Page 8.

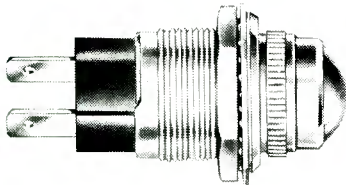

81-1059-0111-102

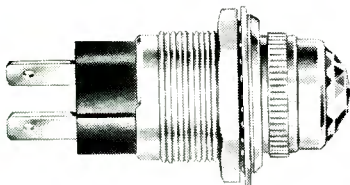

81-1059-0431-102

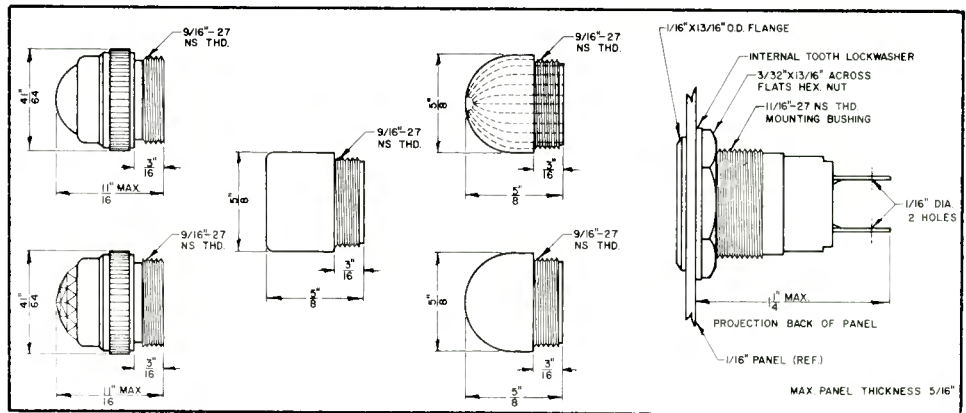

INDICATOR LIGHTS for T-3 1/4 BULB with MINIATURE BAYONET BASE



INCANDESCENT - 2 TO 120 VOLTS

For Mounting in 1" Clearance Hole

These series indicator lights meet or exceed requirements of MIL-L-3661.

MATERIALS AND FINISHES

- **Mounting Bushing:** Standard—Brass, white nickel finish. Optional—Black nickel finish.
- **Lens Holder and Knurled Flange Ring:** Standard—Brass, polished chrome finish. Optional—Black nickel or satin chrome finish.
- **Mounting Nut:** Brass, white nickel finish.
- **Internal-tooth Lockwasher:** Phosphor bronze, white nickel finish.
- **Terminals:** Soldering—Brass, hot tinned with elongated slot.
Screw—Brass, white nickel finish.

The illustrations and catalog numbers given on this page designate assemblies with screw-on or friction-fit lens caps. Bayonet lock lens caps are also available. Information will be furnished on request.



See range of voltages on Page 8

Recognized under the component program of Underwriters' Laboratories Inc.
75W., 125V.

SCREW-ON LENS CAPS

LENS STYLE	LENS FINISH	CATALOG NO. WITH SCREW TERMINALS	CATALOG NO. WITH SOLDER TERMINALS
FLAT	Unfrosted	51-1310-0231-301	51-0410-0231-301
	Back Frosted	51-1310-0211-301	51-0410-0211-301
TORPEDO	Unfrosted	80-1310-0531-301	80-0410-0531-301
	Back Frosted	80-1310-0511-301	80-0410-0511-301
LARGE CONVEX	Unfrosted	61-1310-0231-301	61-0410-0231-301
	Back Frosted	61-1310-0211-301	61-0410-0211-301
DOME	Unfrosted	80-1310-1231-301	80-0410-1231-301
	Back Frosted	80-1310-1211-301	80-0410-1211-301
CONVEX	Unfrosted	51-1310-0131-301	51-0410-0131-301
	Back Frosted	51-1310-0111-301	51-0410-0111-301
FACETED	Transparent	51-1310-0431-301	51-0410-0431-301
TORPEDO FACETED	Unfrosted	80-1310-1331-301	80-0410-1331-301
LARGE TORPEDO	Unfrosted	19-1310-0531-301	19-0410-0531-301

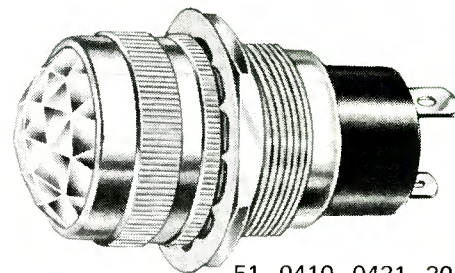

51-0410-0431-301
Faceted lens

The catalog number suffix designates an assembly with standard Polished Chrome finish. To specify optional finish, change the first digit of the catalog number suffix to -2 (black nickel finish) or -4 (satin chrome finish). Example: 80-0410-1211-201.

FRICTION-FIT LENS CAPS

LENS STYLE	LENS FINISH	CATALOG NO. WITH SCREW TERMINALS	CATALOG NO. WITH SOLDER TERMINALS
FLAT	Unfrosted	31-1310-0231-301	31-0410-0231-301
	Back Frosted	31-1310-0211-301	31-0410-0211-301
TORPEDO	Unfrosted	31-1310-0531-301	31-0410-0531-301
	Back Frosted	31-1310-0511-301	31-0410-0511-301
DOME	Unfrosted	31-1310-1231-301	31-0410-1231-301
	Back Frosted	31-1310-1211-301	31-0410-1211-301
CONVEX	Unfrosted	31-1310-0131-301	31-0410-0131-301
	Back Frosted	31-1310-0111-301	31-0410-0111-301
FACETED	Unfrosted	31-1310-0431-301	31-0410-0431-301
TORPEDO FACETED	Unfrosted	31-1310-1331-301	31-0410-1331-301

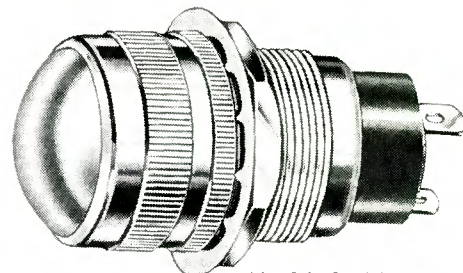

51-0410-0111-301
Convex lens

The footnote shown under the above chart is applicable to these assemblies.

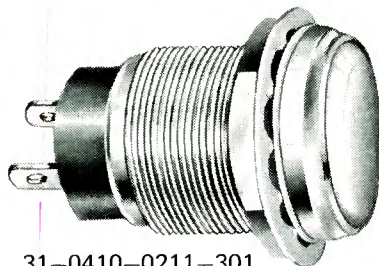

31-0410-0211-301
Flat lens

WATER-TIGHT CONSTRUCTION: Assemblies with screw-on cap may be made water-tight on the face of the panel. To specify, change the last digit in the catalog number suffix to 3. Example: 51-0410-0111-303.

LEGEND DISCS: Indicator lights with flat lens shape will accommodate a legend disc, which is inserted in back of the lens. Words, letters, numerals or symbols appear when lamp is energized. See Page 14 for data.

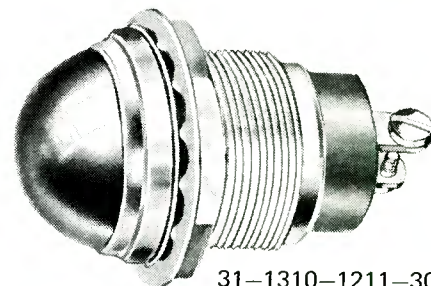

31-1310-1211-301
Dome lens

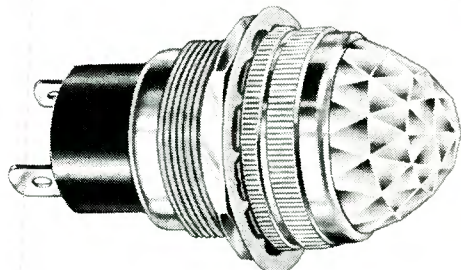

80-0410-1331-301
Torpedo Faceted lens

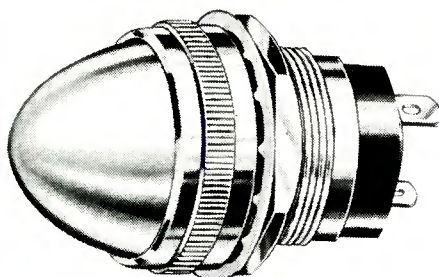

19-0410-0531-301
Large Torpedo lens

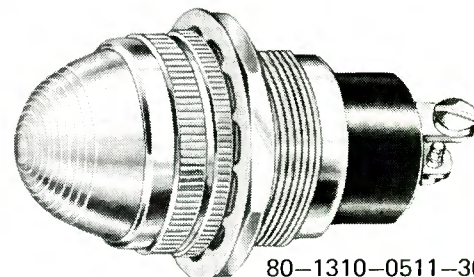

80-1310-0511-301
Torpedo lens

LENS COLOR: See description on Page 14.

SAMPLES ON REQUEST
AT ONCE—NO CHARGE



INDICATOR LIGHTS for

(All illustrations are approx. actual size)

S-6 BULB with DOUBLE CONTACT BAYONET BASE INCANDESCENT - 6 TO 250 VOLTS

S-6 BULB
WITH DOUBLE CONTACT BAYONET BASE
MANUFACTURER'S RATINGS

LAMP NO.	WATTS	VOLTS	HOURS
6S6DC-6V	6	6	1500
6S6DC-12V	6	12	1500
6S6DC-24V	6	24	1500
6S6DC-30V	6	30	1500
6S6DC-48V	6	48	1500
6S6DC-75V	6	75	1500
6S6DC-125V	6	125	1500
6S6DC-135V	6	135	1500
6S6DC-145V	6	145	1500
10S6DC-230V	10	230	1500
10S6DC-250V	10	250	1500

Ratings of lamps are taken from published catalogs of leading lamp manufacturers.

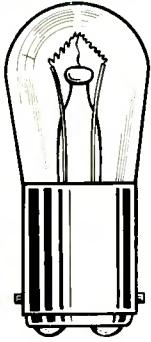

For Mounting in 1" Clearance Hole

These series indicator lights meet or exceed requirements of MIL-L-3661.

MATERIALS AND FINISHES

- **Mounting Bushing:** Standard—Brass, white nickel finish. Optional—Black nickel finish.
- **Lens Holder and Knurled Flange Ring:** Brass, polished chrome finish. Optional—Black nickel or satin chrome finish.
- **Mounting Nut:** Brass, white nickel finish.
- **Internal-tooth Lockwasher:** Phosphor bronze, white nickel finish.
- **Terminals:** **Soldering**—Brass, hot tinned.
Screw—Brass, white nickel finish.
Quick Connect—Brass, tinned. Mate with standard female receptacles.

The illustrations and catalog numbers given on this page designate assemblies with screw-on or friction-fit lens caps. Bayonet lock lens caps are also available. Information will be furnished on request.

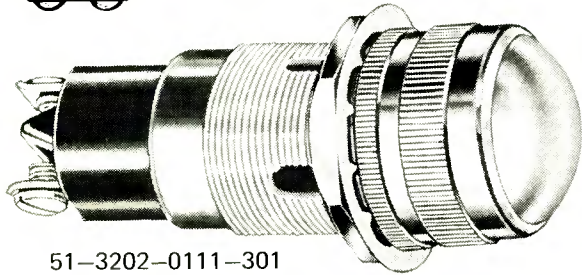

51-3202-0111-301
Convex lens

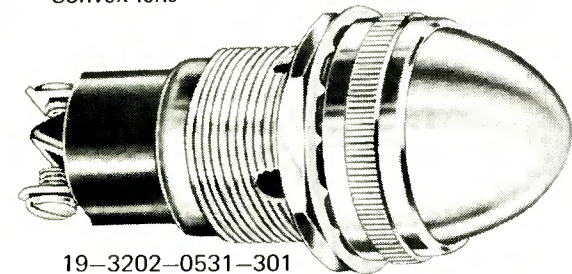

19-3202-0531-301
Large Torpedo lens

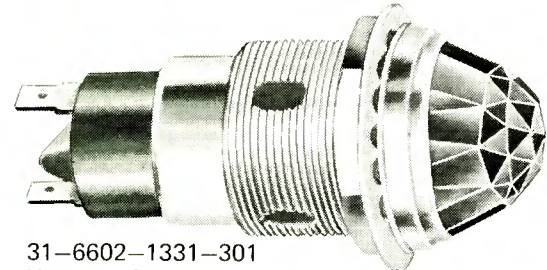

31-6602-1331-301
Torpedo Faceted lens

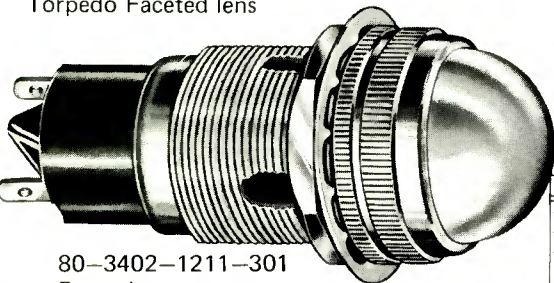

80-3402-1211-301
Dome lens

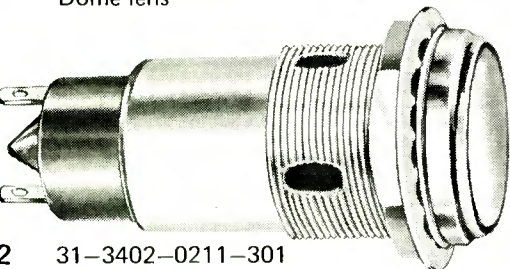

31-3402-0211-301
Flat lens

SCREW-ON LENS CAPS

LENS STYLE	LENS FINISH	CATALOG NO. WITH FIXED SCREW TERMINALS	CATALOG NO. WITH FIXED SOLDER TERMINALS	CATALOG NO. WITH QUICK CONNECT TERMINALS
FLAT	Back Frosted	51-3202-0211-301	51-3402-0211-301	51-6602-0211-301
	Unfrosted	51-3202-0131-301	51-3402-0131-301	51-6602-0131-301
CONVEX	Back Frosted	51-3202-0111-301	51-3402-0111-301	51-6602-0111-301
	Unfrosted	51-3202-0431-301	51-3402-0431-301	51-6602-0431-301
FACETED	Unfrosted	61-3202-0231-301	61-3402-0231-301	61-6602-0231-301
	Back Frosted	61-3202-0211-301	61-3402-0211-301	61-6602-0211-301
LARGE CONVEX	Unfrosted	19-3202-0531-301	19-3402-0531-301	19-6602-0531-301
	Back Frosted	80-3202-1231-301	80-3402-1231-301	80-6602-1231-301
LARGE TORPEDO	Unfrosted	80-3202-1211-301	80-3402-1211-301	80-6602-1211-301
	Back Frosted	80-3202-0531-301	80-3402-0531-301	80-6602-0531-301
DOME	Unfrosted	80-3202-0511-301	80-3402-0511-301	80-6602-0511-301
	Back Frosted	80-3202-1331-301	80-3402-1331-301	80-6602-1331-301
TORPEDO	Unfrosted	31-3202-1331-301	31-3402-1331-301	31-6602-1331-301
	Back Frosted	31-3202-0211-301	31-3402-0211-301	31-6602-0211-301
TORPEDO FACETED	Unfrosted	31-3202-0131-301	31-3402-0131-301	31-6602-0131-301
	Back Frosted	31-3202-0111-301	31-3402-0111-301	31-6602-0111-301

FRICTION-FIT LENS CAPS

LENS STYLE	LENS FINISH	CATALOG NO. WITH FIXED SCREW TERMINALS	CATALOG NO. WITH FIXED SOLDER TERMINALS	CATALOG NO. WITH QUICK CONNECT TERMINALS
FLAT	Back Frosted	31-3202-0211-301	31-3402-0211-301	31-6602-0211-301
	Unfrosted	31-3202-0131-301	31-3402-0131-301	31-6602-0131-301
CONVEX	Back Frosted	31-3202-0111-301	31-3402-0111-301	31-6602-0111-301
	Unfrosted	31-3202-0431-301	31-3402-0431-301	31-6602-0431-301
FACETED	Unfrosted	31-3202-1231-301	31-3402-1231-301	31-6602-1231-301
	Back Frosted	31-3202-1211-301	31-3402-1211-301	31-6602-1211-301
DOME	Unfrosted	31-3202-0531-301	31-3402-0531-301	31-6602-0531-301
	Back Frosted	31-3202-0511-301	31-3402-0511-301	31-6602-0511-301
TORPEDO	Unfrosted	31-3202-1331-301	31-3402-1331-301	31-6602-1331-301
	Back Frosted	31-3202-0211-301	31-3402-0211-301	31-6602-0211-301
TORPEDO FACETED	Unfrosted	31-3202-0131-301	31-3402-0131-301	31-6602-0131-301
	Back Frosted	31-3202-0111-301	31-3402-0111-301	31-6602-0111-301

PER MIL-L-3661B

LENS TYPE DESIGNATION	LENS SHAPE	WITH LH80/I INDICATOR LIGHT HOUSING
LC21	Convex	378-3402-0131-203
LC22	Torpedo	379-3402-0531-203
LC23	Convex, Mech. Dimmer Complete Blackout	380-3402-0131-203
LC24	Convex, Mech. Dimmer Semi-Blackout	381-3402-0131-203

Recognized under the component program of Underwriters' Laboratories Inc.

75W., 125V.



HOW TO DESIGNATE THE THREE DIGIT CATALOG NUMBER SUFFIX (-XXX)

FINISH	RESISTOR	HARDWARE
-2 black nickel	0—None	1—brass
-3 polished chrome		3—water-tight on the face of the panel.
-4 satin chrome		

NOTE: The part numbers given in this catalog indicate standard indicator lights. This table provides the standard and optional designations for Finish and Hardware where appropriate. Example: 61-3402-0231-403 (satin chrome finish with water-tight construction).

PER MIL-L-3661B

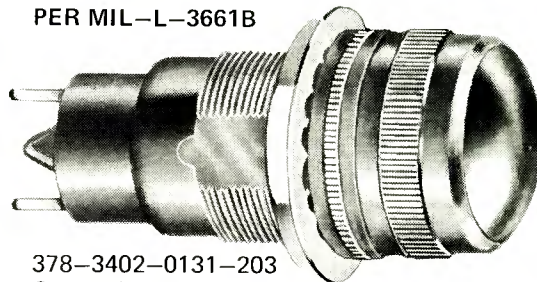

378-3402-0131-203
Convex lens

INDICATOR LIGHTS for

G-6 BULB with DOUBLE CONTACT BAYONET BASE INCANDESCENT - 6 TO 32 VOLTS

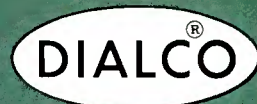

For Mounting in 1" Clearance Hole

These series indicator lights meet or exceed requirements of MIL-L-3661.

MATERIALS AND FINISHES

- **Mounting Bushing:** Standard—Brass, white nickel finish. Optional—Black nickel finish.
- **Lens Holder and Knurled Flange Ring:** Brass, polished chrome finish. Optional—Black nickel or satin chrome finish.
- **Mounting Nut:** Brass, white nickel finish.
- **Internal-tooth Lockwasher:** Phosphor bronze, white nickel finish.
- **Terminals:** Soldering—Brass, hot tinned.
Screw—Brass, white nickel finish.
Quick Connect—Brass, tinned. Mate with standard female receptacles.

G-6 BULB
WITH DOUBLE CONTACT BAYONET BASE

LAMP NO.	VOLTS	AMPS	C.P.	HOURS
82	6.5	1.0	6.0	500
68	13.5	.59	4.0	5000+
90	13.0	.58	6.0	750
304	28.0	.30	6.0	500
1224	32.0	.16	3.0	200

Ratings of lamps are taken from published catalogs of leading lamp manufacturers.

Recognized under the component program of Underwriters' Laboratories Inc.
75W., 125V.

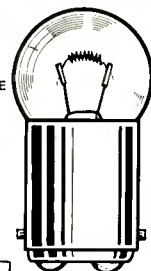

SCREW-ON LENS CAPS

LENS STYLE	LENS FINISH	CATALOG NO. WITH FIXED SCREW TERMINALS	CATALOG NO. WITH FIXED SOLDER TERMINALS	CATALOG NO. WITH QUICK CONNECT TERMINALS
FLAT	Back Frosted	51-3204-0211-301	51-3404-0211-301	51-6604-0211-301
CONVEX	Unfrosted	51-3204-0131-301	51-3404-0131-301	51-6604-0131-301
	Back Frosted	51-3204-0111-301	51-3404-0111-301	51-6604-0111-301
FACETED	Unfrosted	51-3204-0431-301	51-3404-0431-301	51-6604-0431-301
	Back Frosted	61-3204-0231-301	61-3404-0231-301	61-6604-0231-301
LARGE CONVEX	Unfrosted	61-3204-0211-301	61-3404-0211-301	61-6604-0211-301
	Back Frosted	19-3204-0531-301	19-3404-0531-301	19-6604-0531-301
TORPEDO	Unfrosted	80-3204-1231-301	80-3404-1231-301	80-6604-1231-301
	Back Frosted	80-3204-1211-301	80-3404-1211-301	80-6604-1211-301
TORPEDO	Unfrosted	80-3204-0531-301	80-3404-0531-301	80-6604-0531-301
	Back Frosted	80-3204-0511-301	80-3404-0511-301	80-6604-0511-301
TORPEDO FACETED	Unfrosted	80-3204-1331-301	80-3404-1331-301	80-6604-1331-301

WATER-TIGHT CONSTRUCTION: Assemblies with screw-on caps may be made water-tight on the face of the panel. To specify, change the last digit of the catalog number suffix to 3. Examples: 61-3204-0211-303.

FRICTION-FIT LENS CAPS

LENS STYLE	LENS FINISH	CATALOG NO. WITH FIXED SCREW TERMINALS	CATALOG NO. WITH FIXED SOLDER TERMINALS	CATALOG NO. WITH QUICK CONNECT TERMINALS
FLAT	Back Frosted	31-3204-0211-301	31-3404-0211-301	31-6604-0211-301
CONVEX	Unfrosted	31-3204-0131-301	31-3404-0131-301	31-6604-0131-301
	Back Frosted	31-3204-0111-301	31-3404-0111-301	31-6604-0111-301
FACETED	Unfrosted	31-3204-0431-301	31-3404-0431-301	31-6604-0431-301
	Back Frosted	31-3204-1231-301	31-3404-1231-301	31-6604-1231-301
TORPEDO	Unfrosted	31-3204-1211-301	31-3404-1211-301	31-6604-1211-301
	Back Frosted	31-3204-0531-301	31-3404-0531-301	31-6604-0531-301
TORPEDO FACETED	Unfrosted	31-3204-0511-301	31-3404-0511-301	31-6604-0511-301
	Back Frosted	31-3204-1331-301	31-3404-1331-301	31-6604-1331-301

PER MIL-L-3661B

LENS TYPE DESIGNATION	LENS SHAPE	WITH LH79/1 INDICATOR LIGHT HOUSING
LC21	Convex	378-3404-0131-203
LC22	Torpedo	379-3404-0531-203
LC23	Convex, Mech. Dimmer Complete Blackout	380-3404-0131-203
LC24	Convex, Mech. Dimmer Semi-Blackout	381-3404-0131-203

LENS COLOR: See description on Page 14.

The illustrations and catalog numbers given on this page designate assemblies with screw-on or friction-fit lens caps. Bayonet lock lens caps are also available. Information will be furnished on request.

PER MIL-L-3661B

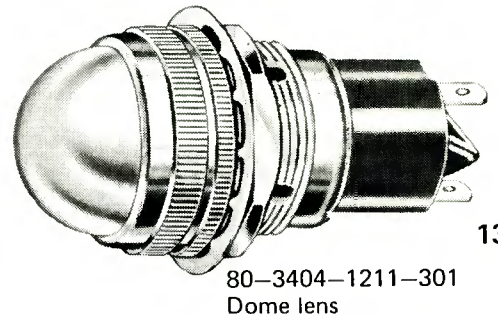
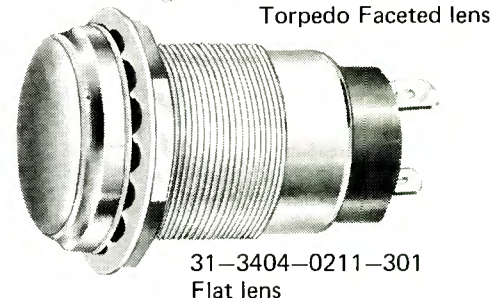
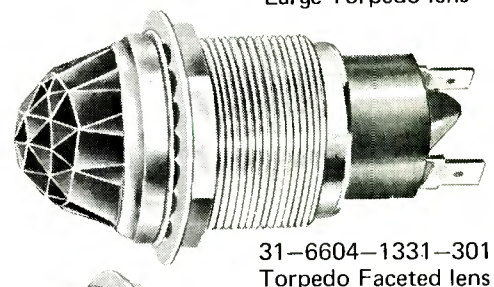
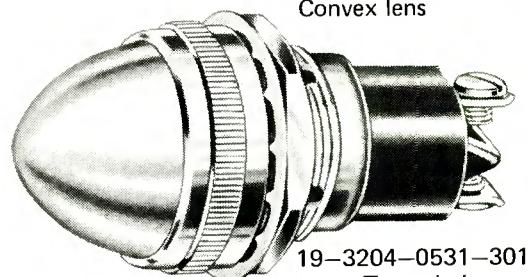
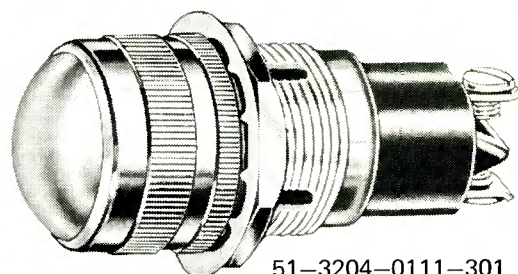
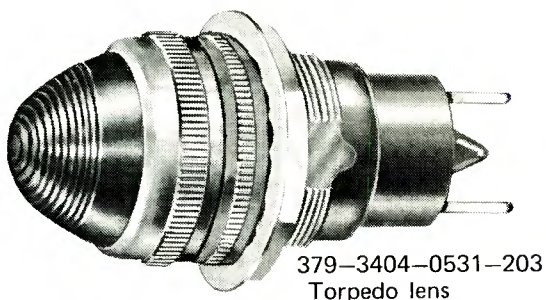



INDICATOR LIGHTS for (All illustrations are approx. actual)

S-6 BULB with CANDELABRA SCREW BASE

INCANDESCENT - 6 TO 250 VOLTS

For Mounting in 1" Clearance Hole

These series indicator lights meet or exceed requirements of MIL-L-3661.

The illustrations and catalog numbers given on this page designate assemblies with screw-on or friction fit lens caps. Bayonet lock lens caps are also available. Information will be furnished on request.

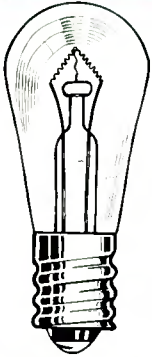

Recognized under the component program of Underwriters' Laboratories Inc.

75W., 125V.

MANUFACTURER'S RATINGS

LAMP NO.	WATTS	VOLTS	HOURS
6S6-6V	6	6	1500
6S6-12V	6	12	1500
6S6-24V	6	24	1500
6S6-30V	6	30	1500
6S6-48V	6	48	1500
6S6-75V	6	75	1500
6S6-125V	6	125	1500
6S6-135V	6	135	1500
6S6-145V	6	145	1500
10S6-230V	10	230	1500
10S6-250V	10	250	1500

Ratings of lamps are taken from published catalogs of leading lamp manufacturers.

MATERIALS AND FINISHES

- **Mounting Bushing:** Standard—Brass, white nickel finish. Optional—Black nickel finish.
- **Lens Holder and Knurled Flange Ring:** Standard—Brass, polished chrome finish. Optional—Black nickel or satin chrome finish.
- **Mounting Nut:** Brass, white nickel finish.
- **Internal-tooth Lockwasher:** Phosphor bronze, white nickel finish.
- **Terminals:** **Soldering**—Brass, hot tinned.
Screw—Brass, white nickel finish.
Quick Connect—Brass, tinned. Mate with standard female receptacles.

SCREW-ON LENS CAPS

LENS STYLE	LENS FINISH	CATALOG NO. WITH SCREW TERMINALS (SIDE POSITION)	CATALOG NO. WITH SCREW TERMINALS (PROTRUDING)	CATALOG NO. WITH SOLDER TERMINALS	CATALOG NO. WITH QUICK CONNECT TERMINALS
CONVEX	Unfrosted	51-0901-0131-301	51-3101-0131-301	51-4001-0131-301	51-6701-0131-301
	Back Frosted	51-0901-0111-301	51-3101-0111-301	51-4001-0111-301	51-6701-0111-301
FLAT	Unfrosted	51-0901-0231-301	51-3101-0231-301	51-4001-0231-301	51-6701-0231-301
	Back Frosted	51-0901-0211-301	51-3101-0211-301	51-4001-0211-301	51-6701-0211-301
LARGE CONVEX	Unfrosted	61-0901-0231-301	61-3101-0231-301	61-4001-0231-301	61-6701-0231-301
	Back Frosted	61-0901-0211-301	61-3101-0211-301	61-4001-0211-301	61-6701-0211-301
TORPEDO	Unfrosted	80-0901-0531-301	80-3101-0531-301	80-4001-0531-301	80-6701-0531-301
	Back Frosted	80-0901-0511-301	80-3101-0511-301	80-4001-0511-301	80-6701-0511-301
DOME	Unfrosted	80-0901-1231-301	80-3101-1231-301	80-4001-1231-301	80-6701-1231-301
	Back Frosted	80-0901-1211-301	80-3101-1211-301	80-4001-1211-301	80-6701-1211-301
TORPEDO FACETED	Unfrosted	80-0901-1331-301	80-3101-1331-301	80-4001-1331-301	80-6701-1331-301
LARGE TORPEDO	Unfrosted	19-0901-0531-301	19-3101-0531-301	19-4001-0531-301	19-6701-0531-301
FACETED	Unfrosted	51-0901-0431-301	51-3101-0431-301	51-4001-0431-301	51-6701-0431-301

NOTE: The catalog number suffix designates an assembly with standard Polished Chrome finish. To specify optional finish, change the first digit of the catalog number suffix to -2 (black nickel finish) or -4 (satin chrome finish) . . . Example: 51-0901-0231-201 (black nickel finish).

FRICTION-FIT LENS CAPS

LENS STYLE	LENS FINISH	CATALOG NO. WITH SCREW TERMINALS (SIDE POSITION)	CATALOG NO. WITH SCREW TERMINALS (PROTRUDING)	CATALOG NO. WITH SOLDER TERMINALS	CATALOG NO. WITH QUICK CONNECT TERMINALS
FLAT	Back Frosted	31-0901-0211-301	31-3101-0211-301	31-4001-0211-301	31-6701-0211-301
CONVEX	Unfrosted	31-0901-0131-301	31-3101-0131-301	31-4001-0131-301	31-6701-0131-301
	Back Frosted	31-0901-0111-301	31-3101-0111-301	31-4001-0111-301	31-6701-0111-301
FACETED	Unfrosted	31-0901-0431-301	31-3101-0431-301	31-4001-0431-301	31-6701-0431-301
DOME	Unfrosted	31-0901-1231-301	31-3101-1231-301	31-4001-1231-301	31-6701-1231-301
	Back Frosted	31-0901-1211-301	31-3101-1211-301	31-4001-1211-301	31-6701-1211-301
TORPEDO	Unfrosted	31-0901-0531-301	31-3101-0531-301	31-4001-0531-301	31-6701-0531-301
	Back Frosted	31-0901-0511-301	31-3101-0511-301	31-4001-0511-301	31-6701-0511-301
TORPEDO FACETED	Unfrosted	31-0901-1331-301	31-3101-1331-301	31-4001-1331-301	31-6701-1331-301

The footnote shown under the above chart is applicable to these assemblies.

WATER-TIGHT CONSTRUCTION: Assemblies with screw-on caps may be made water-tight on the face of the panel. To specify, change the last digit of the catalog number suffix to 3. Example: 80-3101-0531-303.

LENS COLOR: The last digit before the 3 digit catalog number suffix indicates that the lens is RED. When color other than red is desired, change this digit to a figure from the listing below. Note that white lenses are translucent and are always furnished unfrosted.

Red-1; Green-2; Yellow (Amber)-3; Blue-4; White Translucent-5; Light Yellow-6; Clear (Colorless)-7.

SIZE OF TYPE FOR LEGENDS

Number of Characters	Character Height
ONE	.656
TWO	.500
THREE	.375
FOUR	.312

Other legend sizes and configurations may be furnished on application.

LEGEND DISCS: Indicator lights with flat lens shape will accommodate a legend disc, which is inserted in back of the lens. Words, letters, numerals or symbols appear when lamp is energized.

Unless otherwise specified, these standard sizes will be provided in a uniform manner per order—i.e., the size of type will be determined by the largest legend in each individual order.

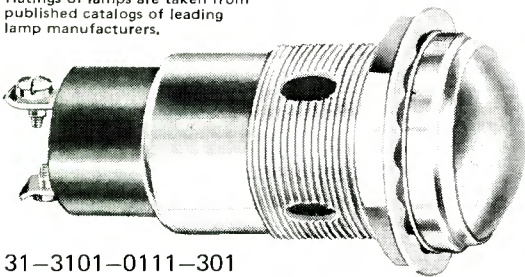

31-3101-0111-301
Convex lens

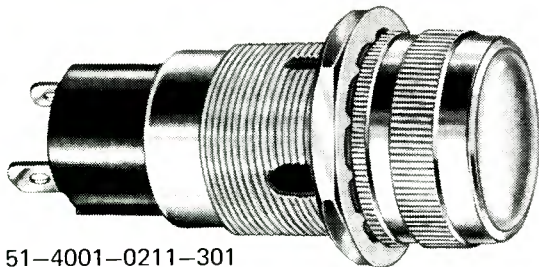

51-4001-0211-301
Flat lens

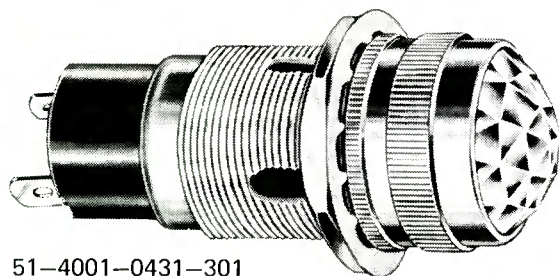

51-4001-0431-301
Faceted lens

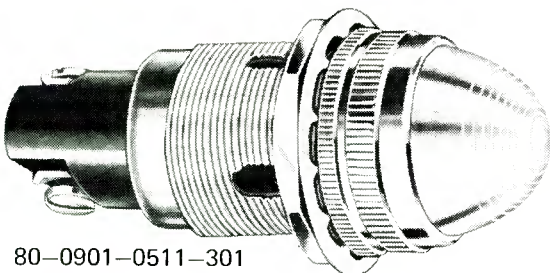

14 80-0901-0511-301
Torpedo lens

SAMPLES ON REQUEST AT ONCE—NO CHARGE

INDICATOR LIGHTS with DIMMER CAPS

MECHANICAL OR POLAROID

INCANDESCENT—ACCOMMODATE S-6 BULB with DOUBLE CONTACT BAYONET or CANDELABRA SCREW BASE



For Mounting in 1" Clearance Hole

These series indicator lights meet or exceed requirements of MIL-L-3661.

DIMMER CAPS
Mechanical or Polaroid —
provide adjustable intensity
of light emission.

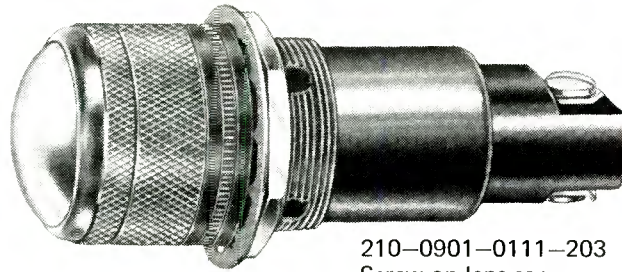
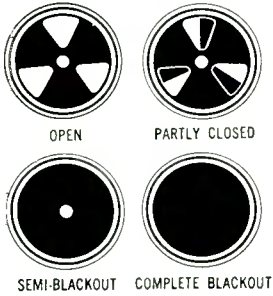

210-0901-0111-203
Screw-on lens cap

MATERIALS AND FINISHES

- Mounting Bushing and Lens Holder: Brass, black nickel finish.
- Mounting Flange (Knurled, Octagon or Round): Brass, black nickel finish.
- Mounting Nut: Brass, white nickel finish.
- Internal-tooth Lockwasher: Phosphor bronze, white nickel finish.
- Terminals: Soldering—Brass, hot tinned with elongated slot.
Screw—Brass, white nickel finish.

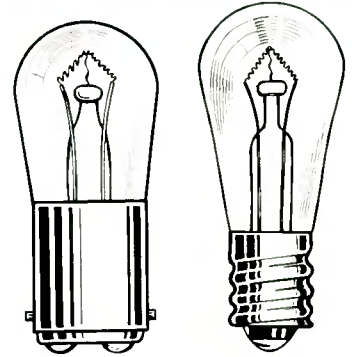

S-6
D.C. BASE
See range of
voltages on
Page 12

S-6
C.S. BASE
See range of
voltages on
facing page

FOR S-6 BULB WITH DOUBLE CONTACT BAYONET BASE

LENS STYLE AND FINISH	MECHANICAL DIMMER TYPE	CATALOG NO. WITH SCREW TERMINALS	CATALOG NO. WITH SOLDER TERMINALS
CONVEX Back Frosted	Semi-Blackout Water-Tight	*210-3202-0111-203	*210-3402-0111-203
	Semi-Blackout Not Water-Tight	*210-3202-0111-201	*210-3402-0111-201
	Complete Blackout Water-Tight	*209-3202-0111-203	*209-3402-0111-203
	Complete Blackout Not Water-Tight	*209-3202-0111-201	*209-3402-0111-201
CONVEX Unfrosted Back Frosted	Polaroid	78-3202-0131-201	78-3402-0131-201
	Polaroid	78-3202-0111-261	78-3402-0111-201

Recognized under the component program of Underwriters' Laboratories Inc.

75W., 125V.



FOR S-6 BULB WITH CANDELABRA SCREW BASE

LENS STYLE AND FINISH	MECHANICAL DIMMER TYPE	CATALOG NO. WITH SCREW TERMINALS	CATALOG NO. WITH SOLDER TERMINALS	CATALOG NO. WITH SCREW TERMINALS (SIDE POSITION)
CONVEX Back Frosted	Semi-Blackout Water-Tight	*210-3101-0111-203	*210-4001-0111-203	*210-0901-0111-203
	Semi-Blackout Not Water-Tight	*210-3101-0111-201	*210-4001-0111-201	*210-0901-0111-201
	Complete Blackout Water-Tight	*209-3101-0111-203	*209-4001-0111-203	*209-0901-0111-203
	Complete Blackout Not Water-Tight	*209-3101-0111-201	*209-4001-0111-201	*209-0901-0111-201
CONVEX Unfrosted Back Frosted	Polaroid	78-3101-0131-201	78-4001-0131-201	78-0901-0131-201
	Polaroid	78-3101-0111-201	78-4001-0111-201	78-0901-0111-201

*New catalog numbers. Prefixes supersede previous catalog number prefixes as follows:

New	Old	New	Old
201-	12B	206-	92SB
202-	12SB	207-	98B
203-	83B	208-	98SB
204-	83SB	209-	71B
205-	92B	210-	71SB

■ Not listed and/or illustrated. Data will be furnished on request.

INCANDESCENT—ACCOMMODATE T-3-1/4 BULB

with MINIATURE BAYONET BASE

For Mounting in 11/16" Clearance Hole

LENS STYLE AND FINISH	MECHANICAL DIMMER TYPE	WITH ROUND FLANGE		WITH OCTAGON FLANGE	
		CATALOG NO. WITH SCREW TERMINALS	CATALOG NO. WITH SOLDER TERMINALS	CATALOG NO. WITH SCREW TERMINALS	CATALOG NO. WITH SOLDER TERMINALS
CONVEX Unfrosted	Semi-Blackout Water-Tight	*204-1310-0131-203	*204-0410-0131-203	*204-5910-0131-203	*204-2210-0131-203
	Semi-Blackout Not Water-Tight	*204-1310-0131-201	*204-0410-0131-201	*204-5910-0131-201	*204-2210-0131-201
	Complete Blackout Water-Tight	*203-1310-0131-203	*203-0410-0131-203	*203-5910-0131-203	*203-2210-0131-203
	Complete Blackout Not Water-Tight	*203-1310-0131-201	*203-0410-0131-201	*203-5910-0131-201	*203-2210-0131-201
CONVEX Back Frosted	Semi-Blackout Water-Tight	*204-1310-0111-203	*204-0410-0111-203	*204-5910-0111-203	*204-2210-0111-203
	Semi-Blackout Not Water-Tight	*204-1310-0111-201	*204-0410-0111-201	*204-5910-0111-201	*204-2210-0111-201
	Complete Blackout Water-Tight	*203-1310-0111-203	*203-0410-0111-203	*203-5910-0111-203	*203-2210-0111-203
	Complete Blackout Not Water-Tight	*203-1310-0111-201	*203-0410-0111-201	*203-5910-0111-201	*203-2210-0111-201
CONVEX Unfrosted	Semi-Blackout	*208-1310-0131-201	*208-0410-0131-201	*208-5910-0131-201	*208-2210-0131-201
	Complete Blackout	*207-1310-0131-201	*207-0410-0131-201	*207-5910-0131-201	*207-2210-0131-201
CONVEX Back Frosted	Semi-Blackout	*208-1310-0111-201	*208-0410-0111-201	*208-5910-0111-201	*208-2210-0111-201
	Complete Blackout	*207-1310-0111-201	*207-0410-0111-201	*207-5910-0111-201	*207-2210-0111-201
CONVEX Unfrosted	Polaroid	93-1310-0131-201	93-0410-0131-201	93-5910-0131-201	93-2210-0131-201
CONVEX Back Frosted	Polaroid	93-1310-0111-201	93-0410-0111-201	93-5910-0111-201	93-2210-0111-201

Screw-in lens cap

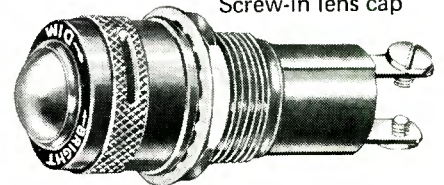

Mechanical Dimmer
with Round Flange
204-1310-0111-201



T-3-1/4
MIN. BAY.
BASE

See range of
voltages on
Page 8

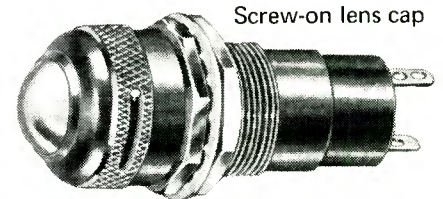

Screw-on lens cap
Polaroid Dimmer
with Octagon Flange
93-2210-0111-201

LENS COLOR: See description on facing page.

(All illustrations are approx. actual size)



INDICATOR LIGHTS with LIGHT SHIELD LENS CAPS

ACCOMMODATE S-6 BULB

with DOUBLE CONTACT BAYONET or CANDELABRA SCREW BASE

INCANDESCENT—6 TO 250 VOLTS

For Mounting in 1" Clearance Hole

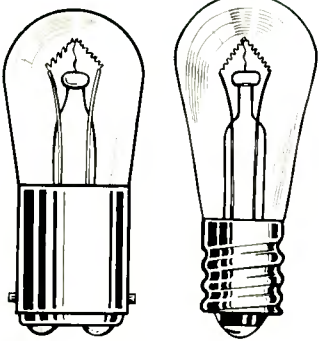

S-6
D.C. BAY.
BASE

S-6
C.S. BASE
See range of
voltages on
Page 14

S-6 BULB
WITH DOUBLE CONTACT BAYONET BASE
MANUFACTURER'S RATINGS

LAMP NO.	WATTS	VOLTS	HOURS
6S6DC-6V	6	6	1500
6S6DC-12V	6	12	1500
6S6DC-24V	6	24	1500
6S6DC-30V	6	30	1500
6S6DC-48V	6	48	1500
6S6DC-75V	6	75	1500
6S6DC-125V	6	125	1500
6S6DC-135V	6	135	1500
6S6DC-145V	6	145	1500
10S6DC-230V	10	230	1500
10S6DC-250V	10	250	1500

Ratings of lamps are taken from published catalogs of leading lamp manufacturers.

Recognized under the component program of Underwriters' Laboratories Inc.

75W., 125V.

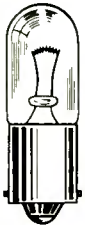

T-3-1/4
MIN. BAY. BASE

See range of
voltages on
Page 8

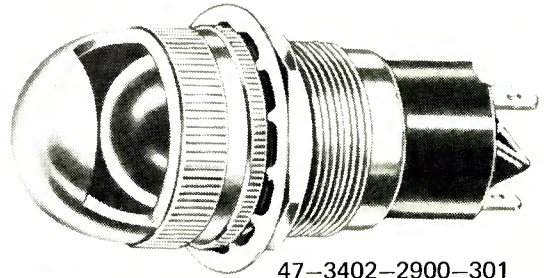
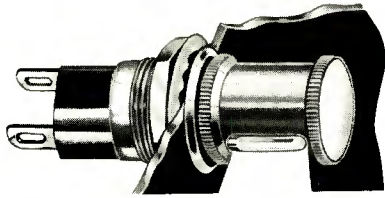

47-3402-2900-301

DOME SHAPE CAP

MATERIALS AND FINISHES: Assemblies with Dome Shape Light Shield Lens Caps:

- **Mounting Bushing:** Standard—Brass, white nickel finish. Optional—Black nickel finish.
- **Light Shield Cap:** Brass, polished chrome finish. Optional—Black nickel finish.
- **Knurled Flange Ring:** Standard—Brass, polished chrome finish. Optional—Black nickel finish.
- **Internal-tooth Lockwasher:** Phosphor bronze, white nickel finish.
- **Terminals: Soldering—** Brass, hot tinned. **Screw—** Brass, white nickel finish.
- **Quick Connect—** Brass, tinned. Mate with standard female receptacles.
- **Mounting Nut:** Brass, white nickel finish.

LIGHT SHIELD LENS CAPS (typical of those illustrated on this page) are effective in directing beams of light onto selected areas on faces of panels or work surfaces. The size of the Light Shield Lens Cap determines the amount of light that falls and illuminates the panel, etc. Excess light is shielded from the viewer's eyes.

FOR S-6 BULB WITH DOUBLE CONTACT BAYONET BASE

TYPE OF LIGHT SHIELD CAP	SIZE OF OPENING IN CAP	CATALOG NO. WITH FIXED SCREW TERMINALS	CATALOG NO. WITH FIXED SOLDER TERMINALS	CATALOG NO. WITH QUICK CONNECT TERMINALS
DOME (With 1 Opening)	1/8" x 1"	50-3202-2900-301	50-3402-2900-301	50-6602-2900-301
	1/4" x 1"	49-3202-2900-301	49-3402-2900-301	49-6602-2900-301
	3/8" x 1"	47-3202-2900-301	47-3402-2900-301	47-6602-2900-301
	9/16" x 1"	151-3202-2900-301	151-3402-2900-301	151-6602-2900-301
PUSH-PULL ACTION (Variable Opening)	From 0" to 1/4" x 7/8"	154-3202-2900-201	154-3402-2900-201	154-6602-2900-201

FOR S-6 BULB WITH CANDELABRA SCREW BASE

TYPE OF LIGHT SHIELD CAP	SIZE OF OPENING IN CAP	CATALOG NO. WITH SCREW TERMINALS (PROTRUDING)	CATALOG NO. WITH SOLDERING TERMINALS	CATALOG NO. WITH QUICK CONNECT TERMINALS
DOME (With 1 Opening)	1/8" x 1"	50-3101-2900-301	50-4001-2900-301	50-6701-2900-301
	1/4" x 1"	49-3101-2900-301	49-4001-2900-301	49-6701-2900-301
	3/8" x 1"	47-3101-2900-301	47-4001-2900-301	47-6701-2900-301
	9/16" x 1"	151-3101-2900-301	151-4001-2900-301	151-6701-2900-301
PUSH-PULL ACTION (Variable Opening)	From 0" to 1/4" x 7/8"	154-3101-2900-201	154-4001-2900-201	154-6701-2900-201

Materials and Finishes for assemblies with Push-Pull Caps: See description below.

OPTIONAL FINISHES

To obtain assemblies with optional finish (see "Materials and Finishes" for each series described on this page), change the first digit of the catalog number suffix. To specify the appropriate optional finish, change this digit to -1 (white nickel finish); -2 (black nickel finish); -3 (polished chrome finish) or -4 (satin chrome finish).

Examples:

47-3202-2900-201
156-1310-2900-301

ACCOMMODATE T-3-1/4 BULB with MINIATURE BAYONET BASE

INCANDESCENT—2 TO 55 VOLTS

For Mounting in 11/16" Clearance Hole

MATERIALS AND FINISHES

- **Mounting Bushing and Light Shield Cap:** (Assemblies with Push-Pull Caps)—Standard . . . Brass, black nickel finish. Optional . . . polished chrome finish. (Assemblies with Push-In Caps)—Standard . . . Brass, polished chrome finish. Optional . . . black nickel or satin chrome finish.
- **Mounting Nut:** Brass, white nickel finish.
- **Internal-tooth Lockwasher:** Phosphor bronze, white nickel finish.
- **Terminal: Soldering—** Brass, hot tinned with elongated slot. **Screw—** Brass, white nickel finish.

See "Optional Finishes" above, and how to designate appropriate catalog numbers.

FOR T-3-1/4 BULB WITH MINIATURE BAYONET BASE

TYPE OF LIGHT SHIELD CAP	SIZE OF OPENING IN CAP	CATALOG NO. WITH SCREW TERMINALS	CATALOG NO. WITH SOLDER TERMINALS
PUSH-IN CAP WITH SNAP LOCK (1 Opening)	3/16" x 9/16"	89-1310-2900-301	89-0410-2900-301
	3/32" x 1/2"	22-1310-2900-301	22-0410-2900-301
	3/16" x 1/2"	90-1310-2900-301	90-0410-2900-301
	1/2" x 1/2"	21-1310-2900-301	21-0410-2900-301
PUSH-PULL ACTION (Variable Opening)	From 0" to 1/4" x 3/8"	156-1310-2900-201	156-0410-2900-201



156-0410-2900-201 PUSH-PULL CAP

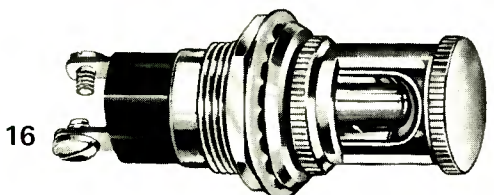

21-1310-2900-301 PUSH-IN CAP

OPEN TYPE INDICATOR LIGHTS

ACCOMMODATE S-6 BULB with CANDELABRA SCREW BASE

INCANDESCENT—6 to 145 VOLTS



For Mounting in 7/16", 11/16" and 1" Clearance Holes

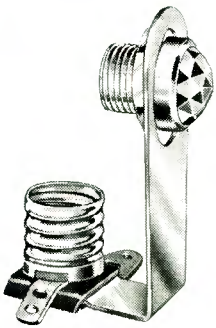

502-1010-2131-102

TAMPER PROOF

LENS TYPE	LENS DIAM.	LENS FINISH	NEW CAT. NO. WITH SOLDER TERMINALS	OLD CAT. NO. WITH SOLDER TERMINALS	FOR MTG. CLEAR. HOLE
FLAT	1/2"	Unfrosted	502-1010-0231-102	10-18-14-231	7/16"
		Back Frosted	502-1010-0211-102	10-18-14-211	7/16"
CONVEX	1/2"	Unfrosted	502-1010-0131-102	10-18-14-131	7/16"
		Back Frosted	502-1010-0111-102	10-18-14-111	7/16"
FACETED	1/2"	Transparent	502-1010-2131-102	10-18-14-431	7/16"

Lens Holder Finish: White Nickel

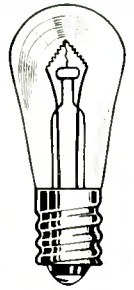

S-6
C.S. BASE
See range of voltages on Page 14.

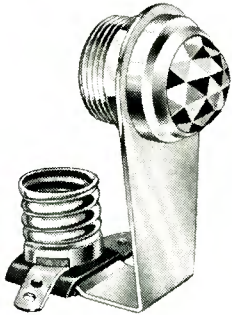

502-2511-0431-302

TAMPER PROOF

LENS TYPE	LENS DIAM.	LENS FINISH	NEW CAT. NO. WITH SOLDER TERMINALS	OLD CAT. NO. WITH SOLDER TERMINALS	FOR MTG. CLEAR. HOLE
CONVEX	5/8"	Unfrosted	502-2511-0131-302	25-18-15-131	11/16"
		Back Frosted	502-2511-0111-302	25-18-15-111	11/16"
FACETED	5/8"	Transparent	502-2511-0431-302	25-18-15-431	11/16"

Lens Holder Finish: Polished Chrome

Recognized under the component program of Underwriters' Laboratories Inc.

75W., 125V.



LENS TYPE	LENS DIAM.	LENS FINISH	NEW CAT. NO. WITH SOLDER TERMINALS	OLD CAT. NO. WITH SOLDER TERMINALS	FOR MTG. CLEAR. HOLE
FACETED	1"	Transparent	502-3214-0431-302	31-18-16-431	1"
CONVEX	1"	Back Frosted	502-3214-0111-302	31-18-16-111	1"
FLAT	1"	Back Frosted	502-3214-0211-302	31-18-16-211	1"

Lens Holder Finish: Polished Chrome

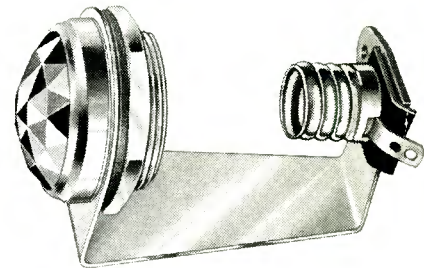

502-3214-0431-302

ACCOMMODATE S-6 or C-7 BULB with DOUBLE CONTACT BAYONET BASE

INCANDESCENT—6 to 125 VOLTS

For Mounting in 1" Clearance Hole

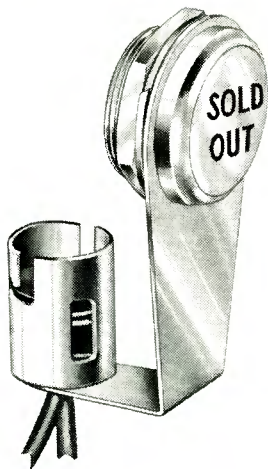

502-7633-0231-302

TAMPER PROOF

LENS TYPE	LENS DIAM.	LENS FINISH	NEW CAT. NO. WITH WIRE LEADS	OLD CAT. NO. WITH WIRE LEADS	FOR MTG. CLEAR. HOLE
FLAT	1"	Unfrosted	502-7633-0231-302	76-12-217-231	1"
	1"	Back Frosted	502-7633-0211-302	76-12-217-211	1"
FLAT	1"	Unfrosted	502-7713-0231-302	31-12-218-XP12-231	1"
	1"	Back Frosted	502-7713-0211-302	31-12-218-XP12-211	1"
FLAT	1"	Unfrosted (with film legend disc)	502-1813-0231-302	31-12-218-XP44-231	1"

Lens Holder Finish: Polished Chrome

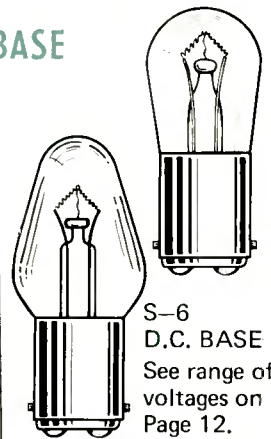

S-6
D.C. BASE
See range of voltages on Page 12.

C-7 D.C. BAY. BASE

NO.	VOLTS	WATTS	HOURS
10C7/DC	120	10	6000
10C7/50C	120	10	6000

Ratings of lamps are taken from published catalogs of leading lamp manufacturers.

LENS COLOR: The last digit before the 3 digit catalog number suffix indicates that the lens is RED. When color other than red is desired, change this digit to a figure from the listing below. Note that white lenses are translucent and are always furnished unfrosted.

Red-1; Green-2; Yellow (Amber)-3; Blue-4; White Translucent-5; Light Yellow-6; Clear (Colorless)-7.

ORDER COMPLETE WITH LAMP so that you will be assured of receiving the indicator light and correct lamp at one time for immediate use.

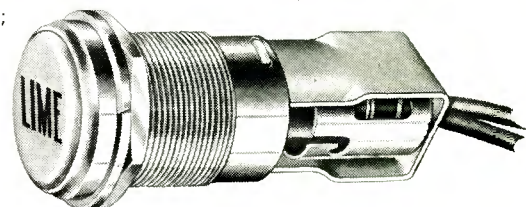

502-1813-0231-302

Illustrations approx. 4/5 actual size.

SAMPLES ON REQUEST AT ONCE—NO CHARGE



OPEN TYPE INDICATOR LIGHTS

ACCOMMODATE T-3-1/4 BULB with MINIATURE BAYONET BASE

INCANDESCENT—2 TO 55 VOLTS

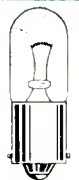

See range of voltages on Page 8.

For Mounting in 9/32", 7/16", 11/16" and 1" Clearance Holes

All assemblies on this page can be furnished with one terminal, grounded to shell.

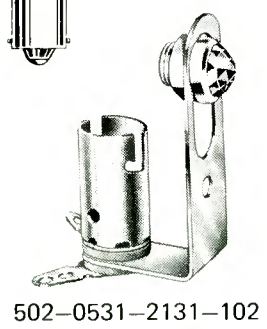

502-0531-2131-102

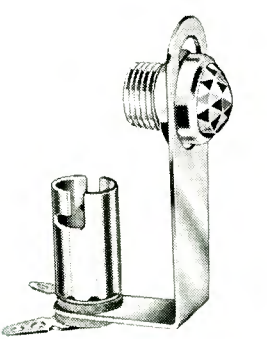

502-1025-2131-102

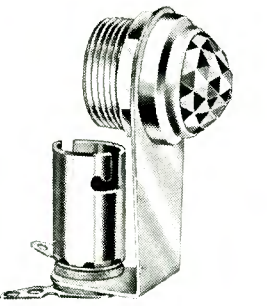

502-2526-0431-302

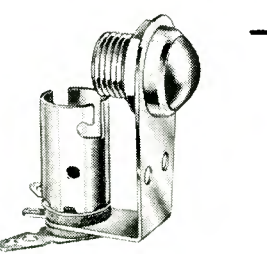

502-1024-0631-102

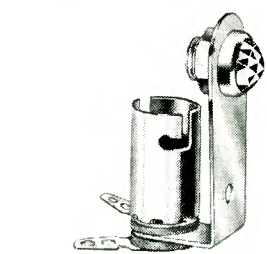

18 502-0530-2131-102

LENS STYLE	LENS DIAM.	LENS FINISH	NEW CAT. NO. WITH SOLDER TERMINALS	OLD CAT. NO. WITH SOLDER TERMINALS	FOR MTG. CLEAR HOLE	LENS HOLDER FINISH
FLAT	1/2"	Transparent	502-1025-0331-102	710U-331	7/16"	White
	1/2"	Translucent	502-1025-0371-102	710U-371	7/16"	Nickel
CONVEX FACETED	1/2"	Unfrosted	502-1025-0631-102	710U-631	7/16"	"
	1/2"	Transparent	502-1025-2131-102	710U-431	7/16"	"
FLAT	3/8"	Transparent	502-0531-0331-102	755U-331	9/32"	"
	3/8"	Translucent	502-0531-0371-102	755U-371	9/32"	"
CONVEX FACETED	3/8"	Unfrosted	502-0531-0631-102	755U-631	9/32"	"
	3/8"	Transparent	502-0531-2131-102	755U-431	9/32"	"
FLAT	5/8"	Transparent	502-2526-0331-302	725-331	11/16"	Polished
	5/8"	Translucent	502-2526-0371-302	725-371	11/16"	Chrome
CONVEX FACETED	5/8"	Unfrosted	502-2526-0631-302	725-631	11/16"	"
	5/8"	Transparent	502-2526-0431-302	725-431	11/16"	"
CONVEX FACETED	1"	Back Frosted	502-3241-0211-302	910B-211	1"	"
	1"	Transparent	502-3241-0111-302	910B-111	1"	"
CONVEX FACETED	1"	Transparent	502-3241-0431-302	910B-431	1"	"
	1/2"	Back Frosted	502-8136-0111-102	810B-111	11/16"	White
CONVEX FACETED	1/2"	Unfrosted	502-8136-0131-102	810B-131	11/16"	Nickel
	1/2"	Transparent	502-8136-2131-102	810B-431	11/16"	"
STOVEPIPE	5/8"	Inside Fluted	502-5236-0991-102	52-810B-991	11/16"	"
STOVEPIPE	5/8"	Transparent	502-9536-0931-102	95-810B-931	11/16"	"
CYLINDRICAL	5/8"	Translucent	502-2436-1471-102	135-810B-1471	11/16"	"

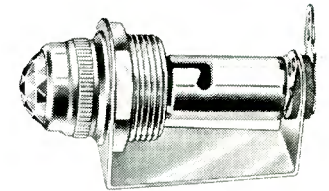

502-8136-2131-102

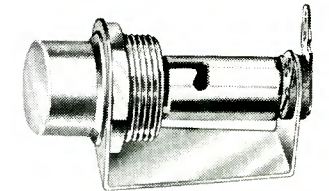

502-2436-1471-102

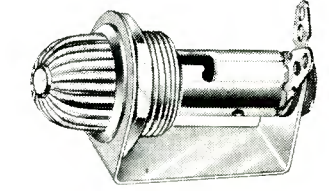

502-5236-0991-102

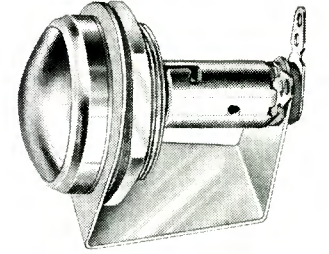

502-3241-0111-302

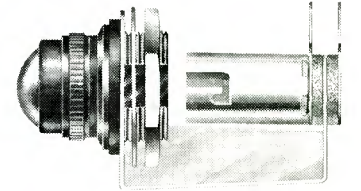

372-8136-0131-203
LH50/1, LC14

PER MIL-L-3661B

LENS TYPE DESIGNATION	LENS SHAPE	WITH LH50/1 INDICATOR LIGHT HOUSING
LC14	Convex	372-8136-0131-203
LC17	Convex, Mech. Dimmer Complete Blackout	372-6236-0131-203
LC18	Convex, Mech. Dimmer Semi-Blackout	372-6336-0131-203

ACCOMMODATE G-3-1/2 BULB with MINIATURE BAYONET BASE

INCANDESCENT

For Mounting in 7/16" and 9/32" Clearance Holes



LENS TYPE	LENS DIAM.	LENS FINISH	NEW CAT. NO. WITH SOLDER TERMINALS	OLD CAT. NO. WITH SOLDER TERMINALS	FOR MTG. CLEAR HOLE
FLAT	1/2"	Transparent	502-1024-0331-102	710-331	7/16"
	1/2"	Translucent	502-1024-0371-102	710-371	7/16"
	3/8"	Transparent	502-0530-0331-102	755-331	9/32"
	3/8"	Translucent	502-0530-0371-102	755-371	9/32"
CONVEX	1/2"	Unfrosted	502-1024-0631-102	710-631	7/16"
	3/8"	Unfrosted	502-0530-0631-102	755-631	9/32"
FACETED	1/2"	Transparent	502-1024-2131-102	710-431	7/16"
	3/8"	Transparent	502-0530-2131-102	755-431	9/32"

Lens Holder Finish: White Nickel.

LENS COLOR: See page 19.

MANUFACTURER'S RATING				
LAMP NO.	VOLTS	AMPS	HRS.	C.P.
51	7.5	.22	1000	1.0
53	14.4	.12	1000	1.0
1445	18.0	.15	250	1.5

Ratings of lamps are taken from published catalogs of leading lamp manufacturers.

Illus. approx. 4/5 actual size.

ORDER COMPLETE WITH LAMP so that you will be assured of receiving the indicator light and correct lamp at one time for immediate use.

LENS CAP ASSEMBLIES FOR PANEL MOUNTING

Or Use With Open Assemblies



514-0408-0331-100 514-0608-2131-100 514-0512-2131-102 514-3806-0631-100 514-1012-2131-102

LENS DIAM.	CATALOG NUMBER WITH			SHANK O.D. ▲	SHANK LENGTH
	FLAT LENS	CONVEX LENS	FACETED LENS		
1 1/32"	514-0408-0331-100	514-0408-0631-100	514-0408-2131-100	.276	1/4"
1 1/32"	514-0508-0331-102	514-0508-0631-102	514-0508-2131-102	9/32"-32 Thd.	1/4"
1 1/32"	514-0512-0331-102	514-0512-0631-102	514-0512-2131-102	9/32"-32 Thd.	3/8"
1 1/32"	514-0608-0331-100	514-0608-0631-100	514-0608-2131-100	.285	1/4"
1 1/32"	514-0710-0331-102	514-0710-0631-102	514-0710-2131-102	3/8"-24 Thd.	5/16"
1/2"	514-3806-0331-100	514-3806-0631-100	514-3806-2131-100	.373	3/16"
1/2"	514-1008-0331-102	514-1008-0631-102	514-1008-2131-102	7/16"-27 Thd.	1/4"
1/2"	514-1012-0331-102	514-1012-0631-102	514-1012-2131-102	7/16"-27 Thd.	3/8"

▲ Decimals + .005

Note: To obtain Flat translucent lens only, change so much of the catalog number that reads -0331- to -0371-. Example: 514-0408-0371-100.

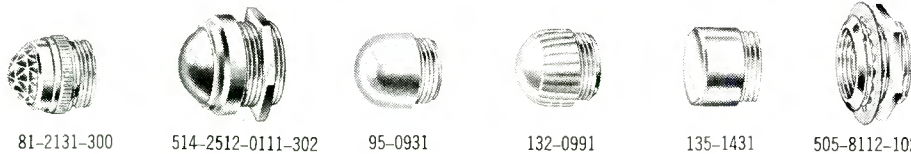

81-2131-300 514-2512-0111-302 95-0931 132-0991 135-1431 505-8112-102

LENS DIAM.	LENS SHAPE	CATALOG NUMBER	SHANK O.D.	SHANK LENGTH
1/2"	FLAT	81-0331-300	9/16"-27 Thd.	3/16"
1/2"	CONVEX	81-0631-300	9/16"-27 Thd.	3/16"
1/2"	FACETED	81-2131-300	9/16"-27 Thd.	3/16"
5/8"	CONVEX	514-2512-0111-302	11/16"-27 Thd.	3/8"
5/8"	FACETED	514-2512-0431-302	11/16"-27 Thd.	3/8"
5/8"	STOVEPIPE	132-0991*	9/16"-27 Thd.	3/16"
5/8"	STOVEPIPE	95-0931*	9/16"-27 Thd.	3/16"
5/8"	CYLINDRICAL	135-1431*	9/16"-27 Thd.	3/16"

505-8112-102

BUSHING ASSEMBLY
Mounts in 11/16" clearance hole. Shank length 3/8". Furnished with nut and lockwasher.

- Specify 505-8112-102 Bushing Assembly for use with these lens cap assemblies (see illus.).
- To obtain translucent lens, change "3" in the catalog number suffix to "7". Example: 95-0972 (green).

OPTIONAL FINISHES

The first digit in the catalog number suffix designates standard finish (exception 95-, 132- and 135- series). The standard and three optional finishes are available for each series and can be specified by changing this digit to -1 (white nickel); -2 (black nickel); -3 (polished chrome) or -4 (satin chrome).
Examples: 514-2512-0111-202;
514-0608-2131-100.

*LENS COLOR: (132-, 95- and 135-series lens caps only) - The last digit in the catalog number designates the lens color. Change this digit for desired color as follows:
Red -1; Green -2; Yellow (Amber) -3; Blue -4; White Translucent -5; Light Yellow -6; Clear (Colorless) -7.

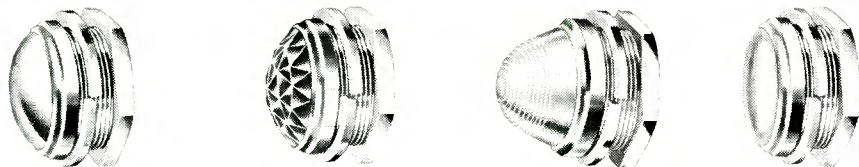

514-7612-0111-302 514-7612-0431-302 514-7612-0511-302 514-7612-0211-302

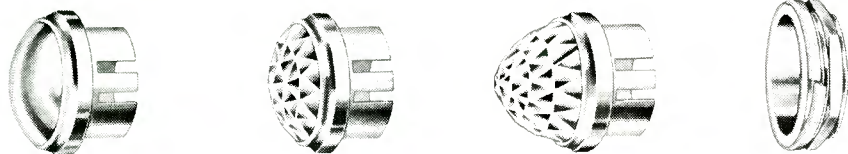

31-0111-300 31-0431-300 31-1331-300 505-3112-102

LENS DIAM.	LENS SHAPE	CATALOG NUMBER	SHANK O.D. ▲	SHANK LENGTH
1"	FLAT	514-7612-0211-302	1"-27 Thd.	3/8"
1"	CONVEX	514-7612-0111-302	1"-27 Thd.	3/8"
1"	FACETED	514-7612-0431-302	1"-27 Thd.	3/8"
1"	TORPEDO	514-7612-0511-302	1"-27 Thd.	3/8"
1"	FLAT	**31-0211-300	.885	5/16"
1"	CONVEX	**31-0111-300	.885	5/16"
1"	FACETED	**31-0431-300	.885	5/16"
1"	DOME	**31-1211-300	.885	5/16"
1"	TORPEDO FACETED	**31-1331-300	.885	5/16"

BUSHING ASSEMBLY
Mounts in 1" clearance hole. Shank length 3/8". Furnished with nut and lockwasher.

- **Specify 505-3112-102 Bushing Assembly for use with this series lens cap assembly (see illus.).
- ▲ Decimals + .005



LENS-CONVEX, 11/32" diam. Choice of colors as listed in chart below.

LENS HOLDER—push-in type with collared shank for secure friction fit. Lens holder O.D., 13/32"; shank length, 3/16". Mounts in 11/32" diam. hole in mounting strip. Made of brass with white nickel finish (standard); other finishes available—see below*.

DIALCO CAT. NO.	WESTERN ELECTRIC PART NO.	LENS FINISH	LENS COLOR
402-0134-100	2W	Unfrosted	Blue
402-0137-100	2BN	Unfrosted	Clear (Colorless)
402-0113-100	2U	Back Frosted	Yellow (Amber)
402-0172-100	2L	Translucent	Green
402-0175-100	2AY	Translucent	White
402-0171-100	2H	Translucent	Red

*Optional—lens holder finishes: black nickel, satin chrome, polished chrome.



LENS-DOME, PLASTIC; 11/32" diam.
LENS HOLDER—same as lens holder described above.

DIALCO CAT. NO.	WESTERN ELECTRIC PART NO.	LENS FINISH	LENS COLOR
402-0871-100	2BS	Translucent	Red
402-0872-100	2BT	Translucent	Green
402-0873-100	---	Translucent	Yellow (Amber)
402-0874-100	---	Translucent	Blue
402-0875-100	2BR	Translucent	White

OPTIONAL FINISHES

(For 402-Series Lens Caps only) To obtain lens caps with optional finish, change the first digit of the catalog number suffix. To specify the appropriate optional finish change this digit to -2 (black nickel finish); -3 (polished chrome finish) or -4 (satin chrome finish).
Examples: 402-0172-200;
402-0875-400.

*W.E.—Western Electric

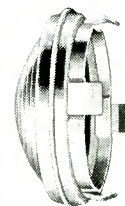

34-0831-300

LENS DIAM.	LENS SHAPE	CATALOG NUMBER	MTG. CLEAR HOLE
1 1/2"	FACETED	34-0431-300	1 3/8"
1 1/2"	DOME	34-0831-300	1 3/8"

LENS COLOR: The last digit before the 3 digit catalog number suffix indicates that the lens is RED. When color other than red is desired, change this digit to a figure from the listing below. Note that white lenses are translucent and are always furnished unfrosted.

Red-1; Green-2; Yellow (Amber)-3; Blue-4; White Translucent-5; Light Yellow-6; Clear (Colorless)-7.

Illus. approx. 2/3 actual size.

DIALIGHT

203 Harrison Place, Brooklyn, N.Y. 11237
Phone: (212) 497-7600



CURRENT LITERATURE

	catalog number	check here
INDICATOR LIGHTS		
Sub-Sub-Miniature.....	L-168.....	<input type="checkbox"/>
Ultra-Miniature	UM-1200 ...	<input type="checkbox"/>
Sub-Miniature		
● One Terminal	L-157	<input type="checkbox"/>
● Edge lighting for Plastic Plates	L-158	<input type="checkbox"/>
● Two Terminals	L-178	<input type="checkbox"/>
Miniature, Large & Misc.		
● Digest of Indicator Lights	L-161	<input type="checkbox"/>
● Flashing Indicators.....	L-211	<input type="checkbox"/>
Oil-Tight	L-200	<input type="checkbox"/>
Press-to-Test	L-201	<input type="checkbox"/>
Placard Lights	L-170	<input type="checkbox"/>

Also available though not listed in this catalog

Switch Product Selector Guide	L-210.....	<input type="checkbox"/>
Readout Product Selector Guide.....	SG742.....	<input type="checkbox"/>
LED Product Selector Guide.....	SG731.....	<input type="checkbox"/>
Indicator Light Product Selector Guide.....	SG730.....	<input type="checkbox"/>

Send for your copies of these Catalogs.

FLASHING FLASHING FLASHING

SNAP-IN NEON FLASHING INDICATOR LIGHT

- FLASHING LIGHT FOR WARNING DEVICE
- SNAP-IN MOUNTING FOR PANELS UP TO 3/16" THICK
- MODERN STYLING – LOW PROFILE CAP WITH BEZEL
- OPERATES ON 110-125 VAC

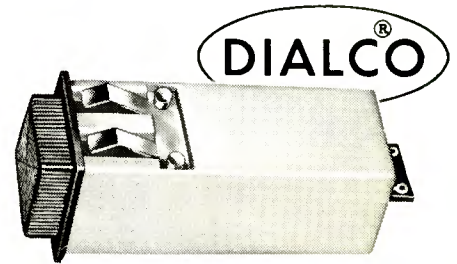

539-1544-1891-001 Flasher

This conventional type indicator light commands attention by flashing "on" and "off" at a nominal rate of 130 flashes per minute when connected to any common control circuitry of 115 VAC.

The attention that flashing lights receive is widely recognized. However, the flash rate must be fast enough to be seen at a glance and yet slow enough to overcome the eye's persistence of vision. In designing for a nominal rate of 130 flashes per minute, consideration was given to the SAE standards on warning lights and emergency electric lanterns. This calls for flash rates between 60 and 200 flashes per minute, the lower figure for incandescent lamps with a specified "on" time and the latter for gaseous discharge (Neon) lamps without any "on" time requirements.

The flashing operation of the lamp is due in part to the bi-stable characteristics of the Neon lamp when combined in a relaxation oscillator circuit. The rate or frequency of flashing is primarily

determined by the resistor capacitor combination in parallel with the aged and selected Neon lamp. Some variation in flash rates is expected due to the tolerances on the components, but not enough to affect its attention-getting value. Life of the high brightness Neon lamp is a minimum of 25,000 hours.

In view of the minimum number of components and simplicity of circuitry, the flashing indicator provides a highly reliable and economical warning device.

The components for the flasher are soldered to a printed circuit board which is enclosed within the case of the indicator. An extending edge of the board exposes the terminations which are eyeletted openings adapted for soldering connections.

The lens systems combine a polished reflector with a cap which has a unique refractive inner surface for directing the light. This is most effective for end-on and side angle visibility, even under high ambient lighting conditions.

SNAP-IN NEON FLASHING INDICATOR LIGHT

Transparent Lens Color	with Black Bezel	with Gray Bezel
Red	539-1544-1891-001	539-1544-1891-002
Yellow (Amber)	539-1544-1893-001	539-1544-1893-002
White	539-1544-1895-001	539-1544-1895-002

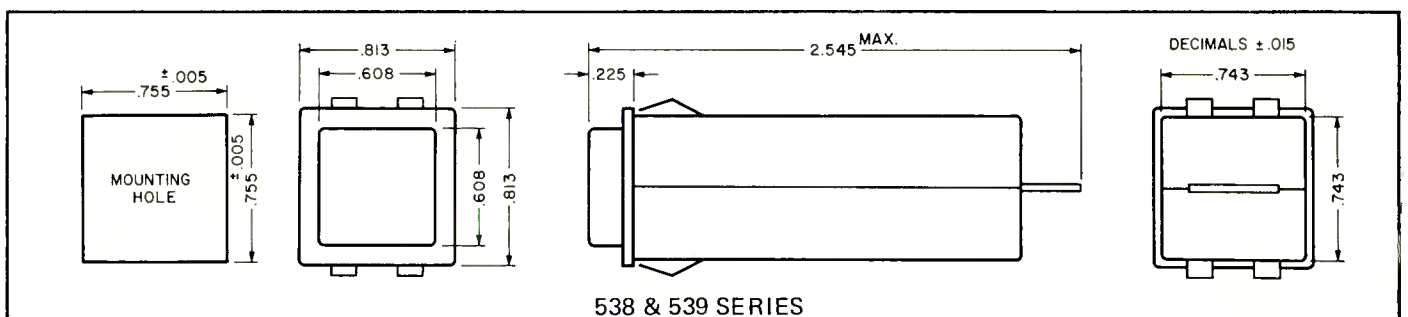
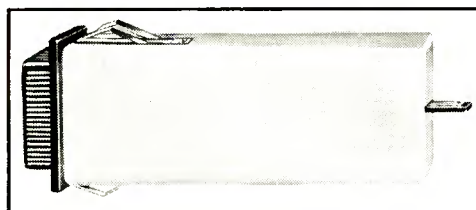

538 & 539 SERIES



SNAP-IN NEON INDICATOR LIGHT

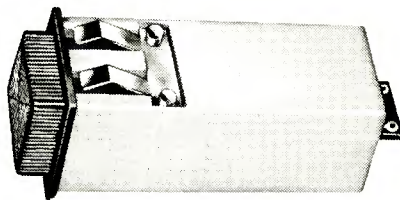

538-0066-1891-031 Indicator

- MODERN STYLING – LOW PROFILE CAP WITH BEZEL
- SNAP-IN MOUNTING FOR PANELS UP TO 3/16" THICK
- OPERATES ON 110-125 VAC

This permanent lamp indicator provides an extremely bright and highly reliable assembly, which utilizes the C2A (NE-2H) Neon lamp. The necessary current-limiting resistor is built into the indicator assembly permitting the direct application of the line voltage to the terminals. Life of the Neon lamp is a minimum of 25,000 hours.

The components for the indicator are soldered to a printed circuit board which is enclosed within the case of the indicator.

An extending edge of the board exposes the terminations which are eyeletted openings adapted for solder connections.

The lens systems combines a polished reflector with a cap

which has a unique refractive inner surface for directing the light. This is most effective for end-on and side angle visibility, even under high ambient lighting conditions.

MATERIALS AND FINISHES

(Flasher and Neon indicator)

- **Housing:** High strength plastic
- **Terminals:** PC board with eyeletted openings for soldering
- **Bezel:** Heat resistant plastic
- **Clip:** Stainless steel
- **Lens Cap:** Plastic with refractive inner surface

SNAP-IN INDICATOR LIGHT

Transparent Lens Color	with Black Bezel	with Gray Bezel
Red	538-0066-1891-031	538-0066-1891-032
Yellow (Amber)	538-0066-1893-031	538-0066-1893-032
White	538-0066-1895-031	538-0066-1895-032

DISTRIBUTED BY:

Printed in U.S.A.
Copyright 1973 by the Dialight Corp., Brooklyn, N.Y. 11237

Dialight Corporation reserves the right to make changes at anytime in order to improve design and to supply the best product possible.

DIALIGHT

A NORTH AMERICAN PHILIPS COMPANY

203 HARRISON PLACE • BROOKLYN, N.Y. 11237 • 212 497-7600 • TWX: 710-584-5487



8 OIL-TIGHT
INDICATOR LIGHTS

8 OIL-TIGHT
INDICATOR LIGHTS



OIL TIGHT INDICATOR LIGHTS

WITH RETAINED "O" RING SEAL CONSTRUCTION

for **HEAVY DUTY**

Industrial Applications

Exceptionally Rugged—designed for severe vibration conditions

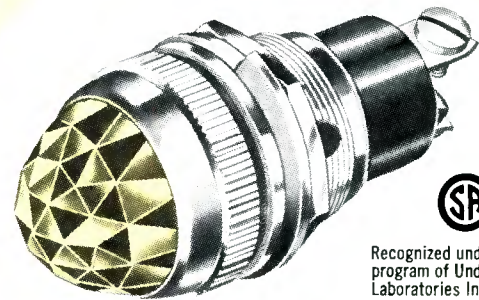

75W., 125V.

Recognized under the component program of Underwriters' Laboratories Inc.

ESSENTIAL FEATURES OF DIALCO'S OIL-TIGHT INDICATOR LIGHTS

- One-piece Solid Brass Mounting Bushing
- Complete Seal on Face of Panel Is Achieved by Use of Retained Oil-proof Gasket and "O" Rings.
- Solid Brass Knurled Lens Holder with Gasketed Lens
- Omnidirectional Permanent Color Lens
- High Impact Phenolic Insulation
- Rugged Terminals—Binding Screw Type
- Single Hole Mounting — 11/16", 1", or 1-3/16"
- Incandescent or Neon Lamps—Screw or Bayonet Type

OIL TIGHT

WATER TIGHT

DUST TIGHT

OMNIDIRECTIONAL

with torpedofaceted lens (as shown above)

How COMPLETE OIL-TIGHTNESS is achieved in this series of DIALCO heavy duty Pilot Lights

As shown in the schematic at the left, oil-tightness — *i.e.* resistance to permeation by oil, water, dust, or fumes—is achieved by means of three retained elastomer seals of inert material, consisting of a gasket and two "O" Rings.

The gasket is used in the assembly of the lens into its metal holder. This part is permanently sealed . . . The first "O" Ring makes the closure when the cap is screwed on to the bushing. The "O" Ring is retained — snapped into a groove cut to receive it. The cap has a skirt which goes over it and prevents it from being squeezed out of place no matter how many times the cap is removed and replaced . . . The second "O" Ring completes the job of sealing everything on the face of the panel by making the seal of the bushing to the panel surface. This "O" Ring, too, is retained by an undercut that forms a confining skirt. No oil, water, dust, or fumes can pass these barriers to interfere with dependable performance.

RUGGED—VIBRATION RESISTANT

Often, in industrial applications, conditions may be really tough. There may be excessive vibration and possibly shock. Temperatures may be high or low. All of these conditions are met and overcome by the relatively simple and compact DIALCO Oil-Tight Pilot Lights. The mounting bushing is made of one-piece solid brass; all other parts are also of heavy solid brass. The molded high-impact phenolic socket is accurately seated in the mounting bushing which is then rolled over to secure it permanently.

All terminals — *Binding Screw, Soldering, or Quick Connect* — are of substantial, rugged construction. The hexagonal brass nut and lockwasher make mounting easy, secure, permanent. Added protection against vibration is afforded by the use of lamps with double contact bayonet base which insures that the lamp will never loosen in its socket.

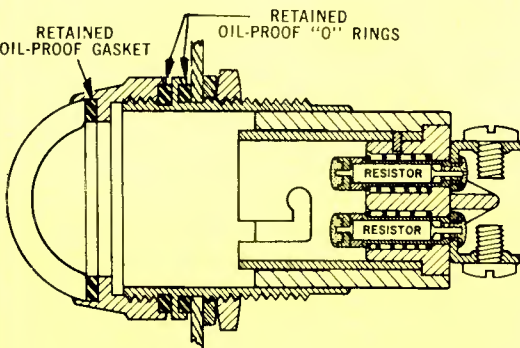

BUILT-IN FEATURES

This cutaway drawing shows how oil-tightness is achieved by a retained gasket and two "O" Rings; also, how resistors are built-in as an integral part of DIALCO units which are made for Neon lamps with bayonet base.

The built-in resistor is an exclusive DIALCO feature—U.S. Pat. No. 2,421,321.



Full 180° light spread is obtained by the use of Dome, Torpedo, or Stovepipe Lenses.

ALL-ANGLE VISIBILITY

DIALIGHT

A NORTH AMERICAN PHILIPS COMPANY

203 HARRISON PLACE • BROOKLYN, N.Y. 11237 • 212 497-7600 • TWX: 710-584-5487



OIL TIGHT INDICATOR LIGHTS

ARE MADE FOR THESE TYPES OF LAMPS
INCANDESCENT OR NEON

LOW VOLTAGE GROUP Selected Listing



T-3 1/4
MINIATURE
BAYONET Base

No.	Manufacturer's Rating			
	Volts	Amps	Hours	C.P.
47	6.3	0.15	3000	0.52
44	6.3	0.25	3000	0.90
1847	6.3	0.15	20000	0.38
1866	6.3	0.25	20000	0.65
755	6.3	0.15	50000	0.33
1815	14.0	0.20	3000	1.4
756	14.0	0.08	50000	0.31
1813	14.4	0.10	3000	0.86
1820	28.0	0.10	1000	1.6
313	28.0	0.17	500	3.5
757	28.0	0.08	50000	0.62

INCANDESCENT LAMPS HIGHER VOLTAGE RANGES

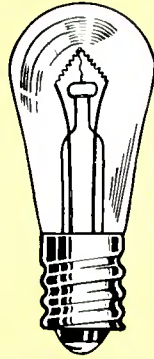

S-6

CANDELABRA
SCREW Base

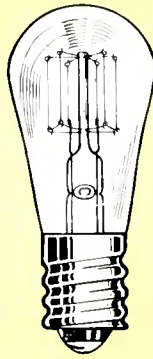

6S6/3*

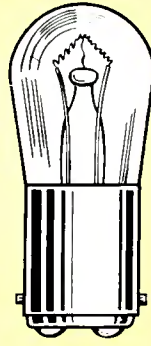

S-6

DOUBLE CONTACT
BAYONET Base

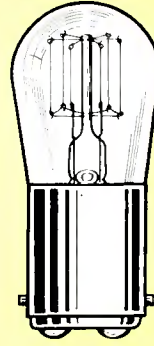

6S6/1*

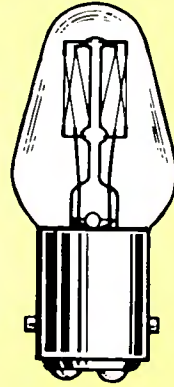

10C7/1DC*
10C7/5DC*
10C7/DC

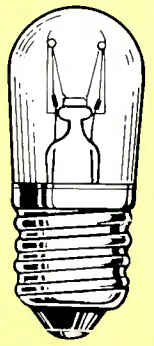

6S6/7

INTERMEDIATE
SCREW Base

The illustration at the left of a T-3 1/4 bulb with miniature bayonet base represents a whole group of low voltage types. The Selected Listing contains the most frequently used lamps. Other ratings will be suggested for particular requirements.

For higher voltages, the S-6 and C-7 types illustrated above offer a choice of voltage ratings and constructions. The use of 125 volt lamps is suggested for 105 to 120 volt circuits. Ratings of 230 and 250 volts are available. For vibration conditions, bayonet bases should be preferred over screw types. The intermediate screw base is desirable on 230 and 250 volt types. Most of these lamps are rated 1500 hours. The 10C7 types have 6000 hour rating at 120 volts. There are no 230 or 250 volt 10C7 lamps.

***THESE LAMPS ARE DESIGNED FOR BETTER RESISTANCE TO VIBRATION.**

NEON GLOW LAMPS

Neon Lamps have particular application in Indicator Lights of rugged construction. They are also resistant to shock and vibration. Their reliability is excellent because normal failure comes by gradual darkening. Light output is small but color is distinctive and effective with yellow, amber or red lenses. No blue or green light is emitted. Neon lamps require a current limiting resistor. The screw base types B7A (NE-45) and F4A (NE-58) contain the resistor in the lamp base, and may be used directly on 120 volt and 250 volt circuits. The three bayonet base types are employed in Indicator Lights in which the resistor is an integral part (an exclusive DIALCO feature—U.S. Pat. No. 2,421,321). The resistor value is chosen to suit the service. Low resistance results in high current and bright light (intermittent service), and high resistance and low current give long life.

BUILT-IN RESISTOR VALUES for the B2A (NE-51H)
and B1A (NE-51) NEON GLOW LAMPS (Values in Ohms)

B2A (NE-51H) High Brightness			B1A (NE-51) Standard Brightness	
Circuit volts applied to terminals 110-125 AC 210-250 AC-DC			Circuit volts applied to terminals 105-125 AC-DC	
BRIGHT LIGHT	■ 22,000	■ 68,000	BRIGHT LIGHT	■ 56,000
LONG LAMP LIFE	33,000	100,000	LONG LAMP LIFE	100,000

■ Standard values of patented built-in resistors. (Other values optional).
Note: The B2A (NE-51H) Neon Glow Lamp is not recommended for use on DC circuits under 160V.

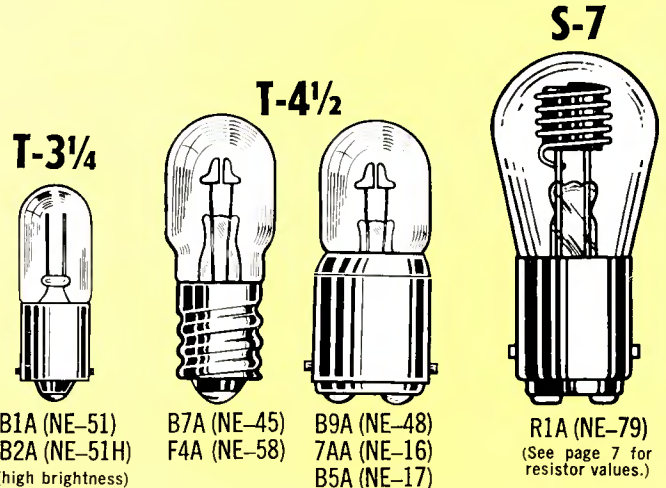

BUILT-IN RESISTOR VALUES for the T-4 1/2 NEON LAMPS
Types B9A (NE-48), 7AA (NE-16), B5A (NE-17)
Recommended resistance values are:

Circuit Volts	Intermittent (Best Light)	Continuous (Long Life)
105-125	■ 16,400 ohms	30,000 ohms
210-250	■ 44,000 ohms	94,000 ohms

■ Standard values of patented built-in resistors.
(Other values optional)

SAMPLES ON REQUEST AT ONCE — NO CHARGE.



OIL TIGHT INDICATOR LIGHTS

FOR NEON OR INCANDESCENT LAMPS WITH
T-3/4 BULB MINIATURE BAYONET BASE

When Connecting a Neon Light to a Circuit Having One Side Grounded, Always
Connect the Hot Side of the Circuit to the Terminal Marked + (Center Contact).

Recognized under the component
program of Underwriters'
Laboratories Inc.



(Illustrations are approx. actual size)

Inserted DISCS (Legends)

For use with INCANDESCENT
lamps only. Neon lamps are not
recommended for use with discs.

See Page 8 for details.

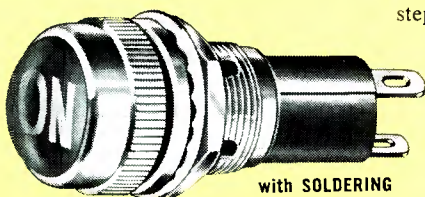

CONVEX

with SOLDERING
terminals

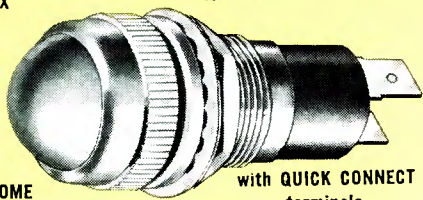

DOME

with QUICK CONNECT
terminals

Requires 11/16" Mounting Clearance Hole

A high degree of resistance to shock and vibration is achieved by the use of the rugged NEON lamps on 120 and 240 volts; and by choosing low voltage INCANDESCENT lamps with short filaments, such as No. 44 or No. 1866 for circuits powered by transformers stepping down to 6.3 volts. See Page 2 for lamp data.

NEON ASSEMBLIES with exclusive BUILT-IN RESISTOR

Dialco Neon Series Indicator Lights
contain an integral built-in resistor—
an exclusive DIALCO feature—U.S.
Pat. No. 2,421,321.

See P. 2
for lamp
data,
including
resistor
values
for Neon
lamps.

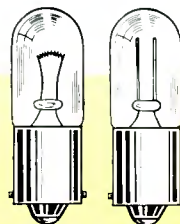

(Incand.) Neon
B1A (NE-51)
B2A (NE-51H)
(High Bright.)

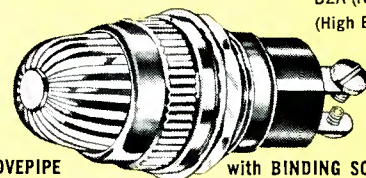

STOVEPIPE
—fluted

with BINDING SCREW
terminals

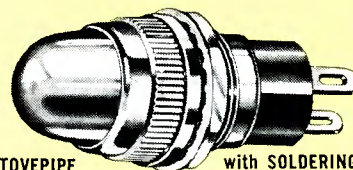

STOVEPIPE
—plain

with SOLDERING
terminals

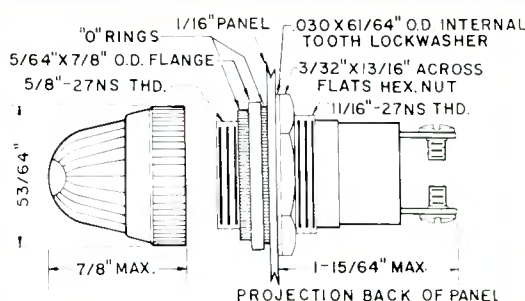
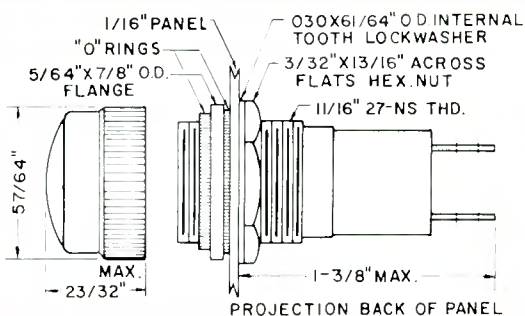

Assemblies for the T-3/4 INCANDESCENT LAMP

LENS TYPE	LENS SURFACE	CATALOG NO. with SCREW terminals	CATALOG NO. with SOLDERING terminals	CATALOG NO. with QUICK CONNECT terminals
CONVEX	unfrosted (with disc)	218-1310-0131-403	218-0410-0131-403	218-5710-0131-403
	back frosted	124-1310-0111-403	124-0410-0111-403	124-5710-0111-403
DOME	unfrosted	123-1310-1231-403	123-0410-1231-403	123-5710-1231-403
	back frosted	123-1310-1211-403	123-0410-1211-403	123-5710-1211-403
STOVEPIPE	unfrosted	125-1310-1131-403	125-0410-1131-403	125-5710-1131-403
	back frosted	125-1310-1111-403	125-0410-1111-403	125-5710-1111-403
	inside fluted	125-1310-1191-403	125-0410-1191-403	125-5710-1191-403

ASSEMBLIES FOR USE WITH B2A (NE-51H) NEON GLOW LAMP

LENS TYPE	LENS SURFACE	CATALOG NO. with SCREW terminals (210-250V. AC-DC)	CATALOG NO. with SOLDER terminals (210-250V. AC-DC)	CATALOG NO. with QUICK CONNECT terminals (210-250V. AC-DC)
DOME	unfrosted	123-9363-1231-463	123-9463-1231-463	123-5863-1231-463
STOVEPIPE	unfrosted	125-9363-1131-463	125-9463-1131-463	125-5863-1131-463
	inside fluted	125-9363-1191-463	125-9463-1191-463	125-5863-1191-463

MATERIALS and FINISHES

(all Series listed on this page)

Mounting Bushing: Brass, white nickel finish. Optional, black nickel finish . . . Lens Holder: Brass, satin chrome finish. Optional, polished chrome or black nickel finish . . . Internal-tooth Lockwasher: Phosphor bronze, white nickel finish. . . Hex Mounting Nut: Brass, white nickel finish.

HOW TO DESIGNATE THE THREE DIGIT CATALOG NUMBER SUFFIX (-XXX)
("Resistor" designations are given for B1A (NE-51) and B2A (NE-51H) lamps. See chart on facing page).

FINISH	RESISTOR	HARDWARE
-2 black nickel	1-22K	3-water-tight,
-3 polished chrome	3-33K	oil-tight on
-4 satin chrome	4-56K	the face of
	6-68K	the panel
	7-100K	

Note: The part numbers given in this catalog indicate standard indicator lights. The above table provides the standard and optional designations for Finish and Resistor where appropriate.

ASSEMBLIES FOR USE WITH B2A (NE-51H) NEON GLOW LAMP

LENS TYPE	LENS SURFACE	CATALOG NO. with SCREW terminals (110-125V. AC)	CATALOG NO. with SOLDER terminals (110-125V. AC)	CATALOG NO. with QUICK CONNECT terminals (110-125V. AC)
DOME	unfrosted	123-1363-1231-413	123-0463-1231-413	123-5763-1231-413
STOVEPIPE	unfrosted	125-1363-1131-413	125-0463-1131-413	125-5763-1131-413
	inside fluted	125-1363-1191-413	125-0463-1191-413	125-5763-1191-413

ASSEMBLIES FOR USE WITH B1A (NE-51) NEON GLOW LAMP

LENS TYPE	LENS SURFACE	CATALOG NO. with SCREW terminals (105-125V. AC-DC)	CATALOG NO. with SOLDER terminals (105-125V. AC-DC)	CATALOG NO. with QUICK CONNECT terminals (105-125V. AC-DC)
DOME	unfrosted	123-1308-1231-443	123-0408-1231-443	123-5708-1231-443
STOVEPIPE	unfrosted	125-1308-1131-443	125-0408-1131-443	125-5708-1131-443
	inside fluted	125-1308-1191-443	125-0408-1191-443	125-5708-1191-443

LENS COLOR: The digit before the last dash in the catalog number designates RED color. When color other than red is desired, change this digit to a figure from the adjacent listing.

Red—1; *Green—2; Yellow (Amber)—3; *Blue—4; White Translucent—5; Light Yellow—6; Clear (Colorless)—7.

*Not recommended with Neon Glow Lamps.

Note: To specify white translucent color (for Neon Indicator Lights only), change so much of the catalog number that reads -1231- to -0835-, from -1131- to -0935-, from -1191- to -0995-. Example: 123-1363-0835-413.



OIL TIGHT INDICATOR LIGHTS

WITH RETAINED "O" RING SEAL CONSTRUCTION

(Illustrations are approx. actual size)

Requires 1" mounting clearance hole

Recognized under the component program of Underwriters' Laboratories Inc.

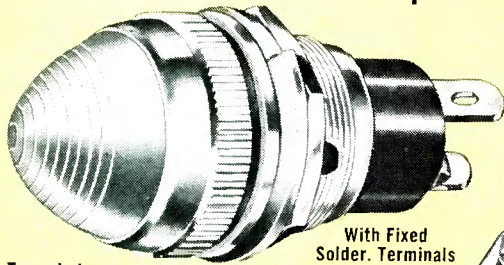

Torpedo Lens

With Fixed Solder. Terminals

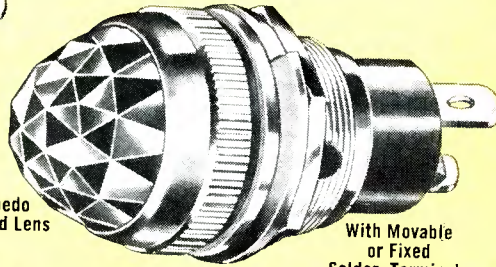

Torpedo Faceted Lens

With Movable or Fixed Solder. Terminals

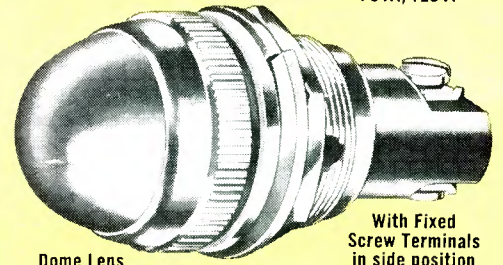

Dome Lens

With Fixed Screw Terminals in side position

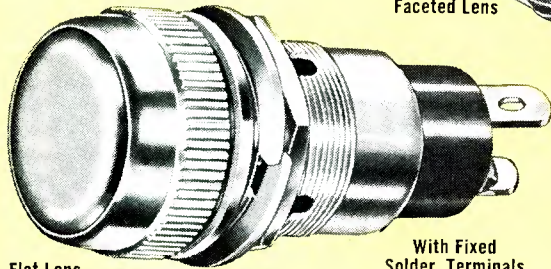

Flat Lens

With Fixed Solder. Terminals

MOVABLE TERMINALS: Terminal part makes direct contact to lamp; no current is carried by springs. Wiring is displaced only 1/16" on insertion of lamp.

FIXED TERMINALS: Connecting wiring may be rigid. No terminal movement during insertion of lamp.

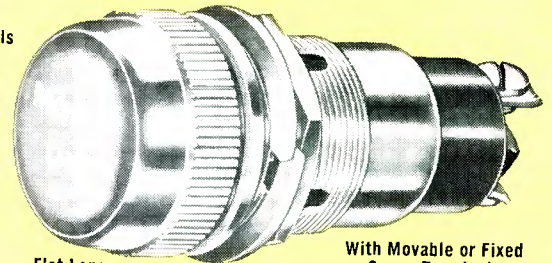

Flat Lens

With Movable or Fixed Screw Terminals

See page 5 for Materials and Finishes available.

Assemblies for Incandescent Lamps (S6 Bulb with Candelabra Screw Base)

LENS TYPE	LENS SURFACE	CATALOG NO. with SCREW terminals in protruding position	CATALOG NO. with SCREW terminals in side position	CATALOG NO. with SOLDERING terminals	PROJECTION (Any Type)		C. to C. Spacing
					Front	*Back	
FLAT	unfrosted (with disc)	215-3101-0231-403	215-0901-0231-403	215-4001-0231-403	51/64"	2-9/64" max.	1-11/32"
	back frosted	104-3101-0211-403	104-0901-0211-403	104-4001-0211-403	"	2-1/32" max.	"
TORPEDO	unfrosted	103-3101-0531-403	103-0901-0531-403	103-4001-0531-403	1-1/8"	1-7/8" max.	"
	back frosted	103-3101-0511-403	103-0901-0511-403	103-4001-0511-403	"	"	"
TORPEDO FACETED	unfrosted	103-3101-1331-403	103-0901-1331-403	103-4001-1331-403	1-1/8"	1-57/64" max.	"
DOME	unfrosted	103-3101-1231-403	103-0901-1231-403	103-4001-1231-403	1-1/8"	1-55/64" max.	"
	back frosted	103-3101-1211-403	103-0901-1211-403	103-4001-1211-403	"	"	"

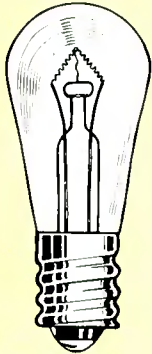

Assemblies for Incandescent Lamps (S6 Bulb with Double Contact Bayonet Base)

LENS TYPE	LENS SURFACE	CATALOG NO. with MOVABLE SCREW terminals	CATALOG NO. with FIXED SCREW terminals	CATALOG NO. with MOVABLE SOLDER terminals	CATALOG NO. with FIXED SOLDER terminals	PROJECTION (Any Type)		C. to C. Spacing
						Front	*Back	
FLAT	unfrosted (with disc)	215-3502-0231-403	215-3202-0231-403	215-3602-0231-403	215-3402-0231-403	51/64"	2-7/64" max.	1-11/32"
	back frosted	104-3502-0211-403	104-3202-0211-403	104-3602-0211-403	104-3402-0211-403	"	2" max.	"
TORPEDO	unfrosted	103-3502-0531-403	103-3202-0531-403	103-3602-0531-403	103-3402-0531-403	1-1/8"	1-57/64" max.	"
	back frosted	103-3502-0511-403	103-3202-0511-403	103-3602-0511-403	103-3402-0511-403	"	"	"
TORPEDO FACETED	unfrosted	103-3502-1331-403	103-3202-1331-403	103-3602-1331-403	103-3402-1331-403	1-1/8"	1-55/64" max.	"
DOME	unfrosted	103-3502-1231-403	103-3202-1231-403	103-3602-1231-403	103-3402-1231-403	1"	1-55/64" max.	"
	back frosted	103-3502-1211-403	103-3202-1211-403	103-3602-1211-403	103-3402-1211-403	"	"	"

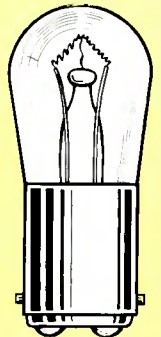

Assemblies for Incandescent Lamps (C7 Bulb with Double Contact Bayonet Base)

LENS TYPE	LENS SURFACE	CATALOG NO. with MOVABLE SCREW terminals	CATALOG NO. with FIXED SCREW terminals	CATALOG NO. with MOVABLE SOLDER terminals	CATALOG NO. with FIXED SOLDER terminals	PROJECTION (Any Type)		C. to C. Spacing
						Front	*Back	
FLAT	unfrosted (with disc)	215-3527-0231-403	215-3227-0231-403	215-3627-0231-403	215-3427-0231-403	51/64"	2-15/32" max.	1-11/32"
	back frosted	104-3527-0211-403	104-3227-0211-403	104-3627-0211-403	104-3427-0211-403	"	"	"
TORPEDO	unfrosted	103-3527-0531-403	103-3227-0531-403	103-3627-0531-403	103-3427-0531-403	1-1/8"	2-7/64" max.	"
	back frosted	103-3527-0511-403	103-3227-0511-403	103-3627-0511-403	103-3427-0511-403	"	"	"
TORPEDO FACETED	unfrosted	103-3527-1331-403	103-3227-1331-403	103-3627-1331-403	103-3427-1331-403	1-1/8"	2-7/64" max.	"
DOME	unfrosted	103-3527-1231-403	103-3227-1231-403	103-3627-1231-403	103-3427-1231-403	1"	2-3/16" max.	"
	back frosted	103-3527-1211-403	103-3227-1211-403	103-3627-1211-403	103-3427-1211-403	"	"	"

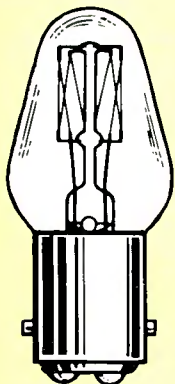

LENS COLOR: The digit before the last dash in the catalog number designates RED color. When color other than red is desired, change this digit to a figure shown below. Example: 103-3627-1333-403 (Amber).
 Red—1; Green—2; Yellow (Amber)—3; Blue—4; White Translucent—5;
 Light Yellow—6; Clear (Colorless)—7.



OIL TIGHT INDICATOR LIGHTS

FOR 5-6 INCANDESCENT LAMPS with INTERMEDIATE SCREW BASE

Recognized under the component program of Underwriters' Laboratories Inc.



75W., 250V.

Requires $1\frac{3}{16}$ " mounting clearance hole

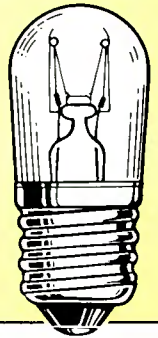

ESPECIALLY SUITABLE FOR HEAVY DUTY EQUIPMENT
LARGE LENS AREA FOR LEGIBLE LEGEND PRESENTATION

LAMPS WITH THIS LARGER SCREW BASE AND SOCKET
PROVIDE ADEQUATE ELECTRICAL CLEARANCE FOR 250 VOLTS

MATERIALS and FINISHES FOR THE 1" and 1-3/16" ASSEMBLIES

Mounting Bushing: Brass, white nickel finish; optional black nickel finish . . . *Lens Holder:* Brass, satin chrome finish; optional polished chrome or black nickel finish . . . *Split Lockwasher:* Steel, cadmium plated, iridite finish . . . *Hex Mounting Nut:* Brass, white nickel finish.

LAMP NO.	VOLTS
6S6/7	125
10S6/13	230
10S6/13	250

OPTIONAL FINISHES

The first digit in the catalog number suffix (as given in the tables) designate standard satin chrome finish. To specify optional finish, change this digit to: -2 (black nickel) or -3 (polished chrome). Example: 115-4733-1231-303.

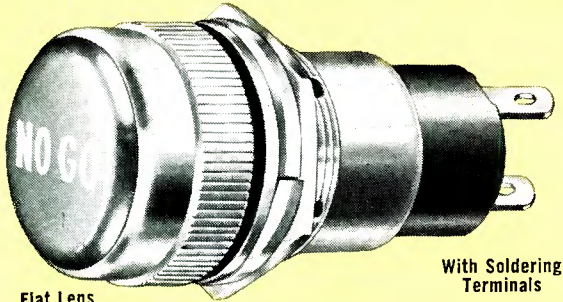

Flat Lens

With Soldering Terminals

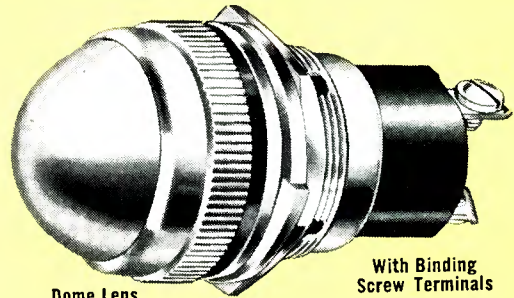

Dome Lens

With Binding Screw Terminals

LENS TYPE	LENS SURFACE	CATALOG NO. with SCREW terminals	CATALOG NO. with SOLDERING terminals	PROJECTION (Either Type)		C. to C. Spacing
				Front *based on 1/16" panel thickness	*Back	
FLAT	unfrosted (with disc)	216-4733-0231-403	216-4833-0231-403	7/8"	1-15/16"	1-11/16"
	back frosted	116-4733-0211-403	116-4833-0211-403	"	"	"
DOME	unfrosted	115-4733-1231-403	115-4833-1231-403	1-1/16"	1-11/16"	"
	back frosted	115-4733-1211-403	115-4833-1211-403	"	"	"

LENS COLOR: The digit before the last dash in the catalog number designates RED color. When color other than red is desired, change this digit to a figure shown below. Example: 116-4733-0212-403 (Green).

Red—1; Green—2; Yellow (Amber)—3; Blue—4; White Translucent—5; Light Yellow—6; Clear (Colorless)—7.

ORDER COMPLETE WITH LAMP so that you will be assured of receiving the indicator light and correct lamp ready for immediate use.

For mounting any 1" assembly in a 1-3/16" clearance hole: Adaptor Set—Cat. No. 515-1316

The Adaptor Set consists of a reducer (A) equipped with gasket (B) to fit the 1-3/16" clearance hole, which is sometimes standard, and a washer (C) for under panel mounting.

This set makes it easy to use the streamlined 1" Dialco assembly where it is inconvenient to provide the smaller hole which it fits directly.

Provision of the retained gasket on the reducer assures the same oil-tightness that is obtained with Dialco assemblies mounted in the regular way.

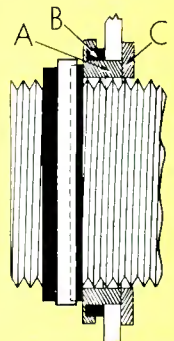

SAMPLES ON REQUEST AT ONCE — NO CHARGE.

DIALIGHT

203 HARRISON PLACE • BROOKLYN, N.Y. 11237 • 212 497-7600 • TWX: 710-584-5487

A NORTH AMERICAN PHILIPS COMPANY



OIL TIGHT INDICATOR LIGHTS

FOR B7A (NE-45) and B9A (NE-48) NEON LAMPS

(Illustrations approx. actual size)

Recognized under the component program of Underwriters' Laboratories Inc.



75W., 125V.

Requires 1" Mounting Clearance Hole

Wide Angle Visibility

The use of Neon lamps is suggested when vibration is too severe for incandescent filaments, or when long lamp life and high reliability are desired.

Screw base lamps B7A (NE-45) and F4A (NE-58) operate directly on their rated circuit voltages:

B7A (NE-45)—105 to 125V; F4A (NE-58)—210 to 250V.

Lamp B9A (NE-48) is used in DIALCO Indicator lights which have the required resistor *built-in* as an integral part of the assembly (U.S. Pat. No. 2,421,321), as discussed on page 1.

The proper resistor value may be chosen from the table below to suit intermittent or continuous service and the applicable circuit voltage.

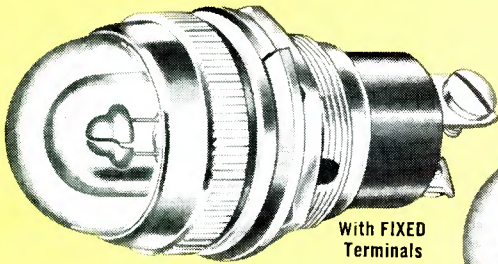

With FIXED Terminals

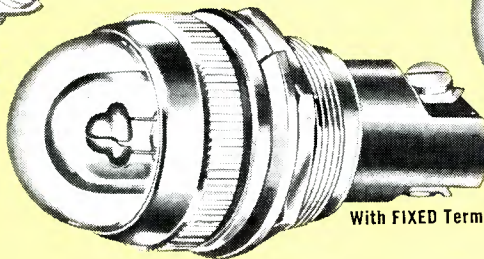

With FIXED Terminals

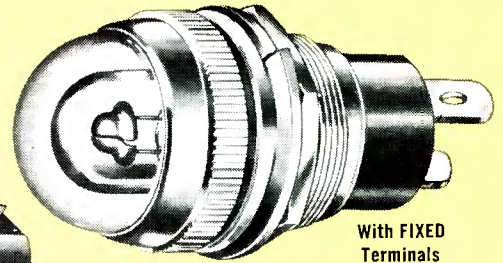

With FIXED Terminals

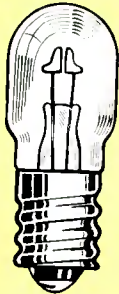

B7A (NE-45)
F4A (NE-58)

LENS TYPE	LENS SURFACE	CATALOG NO. with SCREW terminals in protruding position	CATALOG NO. with SCREW terminals in side position	CATALOG NO. with SOLDERING terminals
DOME	not matted	103-3114-1231-403	103-0914-1231-403	103-4014-1231-403
	back matted	103-3114-0841-403	103-0914-0841-403	103-4014-0841-403

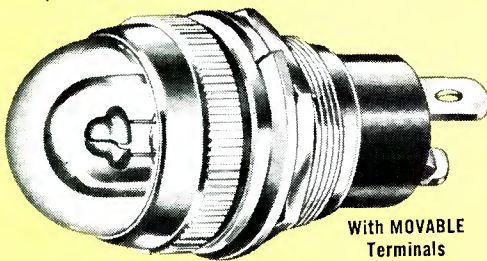

With MOVABLE Terminals

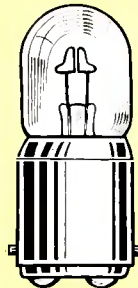

B9A (NE-48)

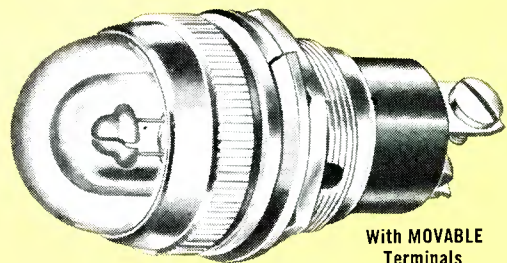

With MOVABLE Terminals

LENS TYPE	LENS SURFACE	CATALOG NO. with MOVABLE SCREW terminals and built-in resistor*	CATALOG NO. with MOVABLE SOLDER terminals and built-in resistor*
DOME	not matted	103-5406-1231-433	103-5306-1231-433
	back matted	103-5406-0841-433	103-5306-0841-433

Double Contact Bayonet Base

See page 5 for Materials and Finishes available.

*The second digit in the catalog number suffix denotes a built-in 16.4K resistor. For other resistance values, change this digit to the appropriate designation found in the chart at right. Example: 103-5406-1231-443 (30K resistor for Long Life on 105-125V circuit).

LAMPS 7AA (NE-16), B5A (NE-17), B9A (NE-48)
RECOMMENDED BUILT-IN RESISTANCE VALUES and APPROPRIATE CATALOG NUMBER DESIGNATIONS

105-125 VOLTS	RECOMMENDED RESISTOR	CODE NO.	210-250 VOLTS	RECOMMENDED RESISTOR	CODE NO.
BEST LIGHT	■ 16.4K	3	BEST LIGHT	44K	5
LONG LIFE	30K	4	LONG LIFE	94K	7

■ Standard value of patented built-in resistor. (Other values optional.)

LENS COLOR: The digit before the last dash in the catalog number designates RED color. When color other than red is desired, change this digit to a figure shown below. Red-1; Yellow (Amber)-3; White Translucent-5; Light Yellow-6; Clear (Colorless)-7.

Example: 103-3114-1233-403 (Yellow Amber).

Green and Blue lens colors have not been listed. These colors are not recommended for use with Neon lamps.

NOTE: To specify white translucent color (for Neon Indicator Lights only), change so much of the catalog number that reads -1231- to -0835-. Example: 103-5306-0835-433.

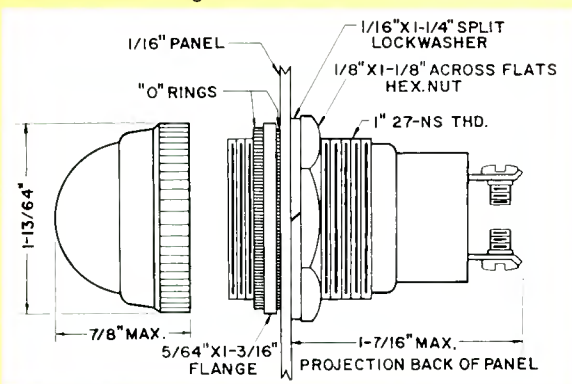



OIL TIGHT INDICATOR LIGHTS

FOR THE HIGHER POWERED NEON LAMP R1A (NE-79)
WITH BAYONET MOUNTING

(Illustrations approx. actual size)

Recognized under the component program of Underwriters' Laboratories Inc.



75W., 125V.

Requires 1" mounting clearance hole PLASTIC LENSES

These rugged lights give the maximum effectiveness possible with Neon lamps. The high domed lens, called "stovepipe", permits excellent visibility from every angle. The plastic lens affords the clarity of glass and range of pure colors without the fragility of glass.

Lamp R1A (NE-79) is the highest powered and brightest of all Neon lamps. The current limiting resistors may be chosen to give a very high level of performance when service is intermittent. On the other hand, use of a higher resistance value assures long life. In either case, reliability is exceptional because lamps darken gradually and do not burn out.

NEON GLOW LAMP With Double Contact Bayonet Base

When a DIALCO Indicator Light is to employ the R1A (NE-79) Neon Lamp, it is provided with two resistors built into the socket assembly—U.S. Pat. No. 2,421,321 (see schematic below). With the voltage distributed between two resistors, it is possible to safely connect this light to 250 volts. The resistor values suggested for various service conditions are shown in the table below.

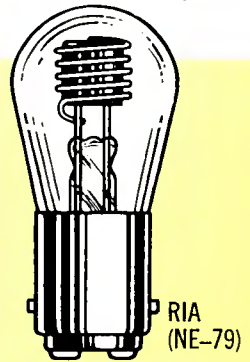

LAMP R1A (NE-79) 1 Watt ONLY

RECOMMENDED BUILT-IN RESISTANCE VALUES and APPROPRIATE CATALOG NUMBER DESIGNATIONS

105-125 VOLTS	RECOMMENDED RESISTOR	CODE NO.	210-250 VOLTS	RECOMMENDED RESISTOR	CODE NO.
BRIGHT LIGHT	3K	1	BRIGHT LIGHT	*	
LONG LIFE	6K	2	LONG LIFE	60K	6

*Standard value of patented built-in resistor. (Other values optional.)

*9,400 ohms is recommended for bright light and intermittent service. Since the wattage to be dissipated with this loading exceeds one watt, it is not possible to build-in the resistors of sufficient capacity. The use of two (2) 4,700 ohms 2 watt resistors, one at each connection of the indicator light is recommended.

See page 5 for Materials and Finishes available.

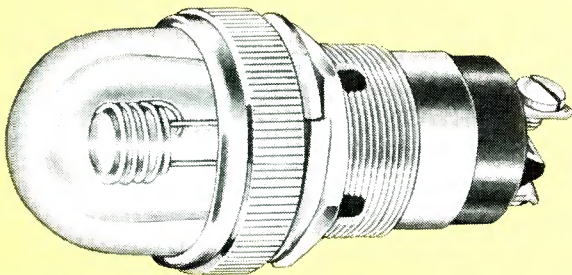

With MOVABLE SCREW Terminals
(Terminals displaced 1/16")

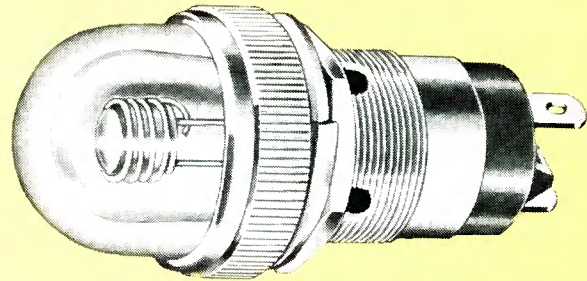

With MOVABLE SOLDERING Terminals
(Terminals displaced 1/16")

PLASTIC LENS TYPE	LENS SURFACE	CATALOG NO. with MOVABLE SCREW terminals and built-in resistor▲	CATALOG NO. with MOVABLE SOLDER terminals and built-in resistor▲	PROJECTION (Either Type)		C. to C. Spacing
				Front *based on 1/16" panel thickness	Back thickness	
STOVEPIPE	unfrosted	159-5437-0931-413	159-5337-0931-413	1-5/16"	1-21/32"	1-7/16"
	back frosted	159-5437-0911-413	159-5337-0911-413	"	"	"

▲The second digit in the catalog number suffix denotes a built-in 3K resistor. For other resistance values, change this digit to the appropriate designation found in the above chart. Example: 159-5437-0933-423 (6K resistor for Long Life on 105-125V circuit).

NOTE: To designate an assembly without built-in resistor (required resistance to be externally mounted), change so much of the catalog number that reads -5437- or -5337- to -3537- or -3637- respectively. It is also necessary to change the second digit in the catalog number suffix to "0". Example: 159-3537-0937-403.

LENS COLOR: The digit before the last dash in the catalog number designates RED color. When color other than red is desired, change this digit to a figure shown below. Red-1; Yellow (Amber)-3; White Translucent-5; Light Yellow-6; Clear (Colorless)-7.

Example: 159-5437-0916-413 (Light Yellow).

Green and Blue lens colors have not been listed. These colors are not recommended for use with Neon lamps.

BUILT-IN FEATURES

This cutaway drawing shows how oil-tightness is achieved by a retained gasket and two "O" Rings; also, how resistors are built-in as an integral part of DIALCO units which are made for Neon lamps with bayonet base.

The built-in resistor is an exclusive DIALCO feature—U.S. Pat. No. 2,421,321.

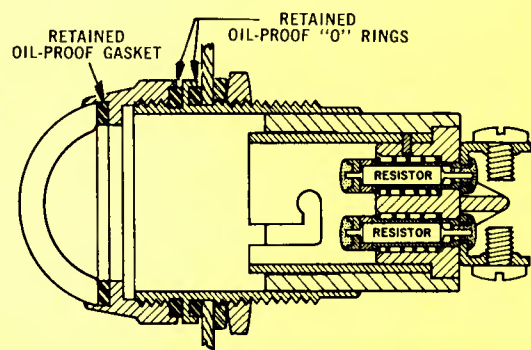



OIL TIGHT INDICATOR LIGHTS

WITH RETAINED "O" RING SEAL CONSTRUCTION

Informative Discs Enhance the Function of Pilot Lights.

They also provide an added safety feature for the protection of personnel and equipment.

Often it is desirable to have a *word, symbol, numeral or letter* appear when the lamp is lighted. A **disc** is inserted behind the lens during assembly of the lens into the lens holder. A full range of colored unfrosted lenses can be provided.*

THE LEGENDS ILLUSTRATED ARE TYPICAL OF THOSE THAT CAN BE SUPPLIED. THOUSANDS OF STANDARD TYPE DISCS ARE AVAILABLE.

TYPE "B"—Black letters on an illuminated background. (Designated as a **POSITIVE** disc.)



TYPE "C"—Illuminated letters on a black background. (Designated as a **NEGATIVE** disc.)



SPACE AVAILABLE FOR LEGENDS

Lens size (diam.)	1-3/16"	1"	3/4"
Maximum Legend area ■	1"	3/4"	5/8"

■ Dimension given is the horizontal and vertical limit in a circular space.

A legend placed behind a flat lens affords the best side angle visibility

Types "B" and "C" discs can be obtained in *parchment, film or glass*. Whenever film is used (*photo-negative or photo-positive*) a white glass diffusing disc is placed behind the film to diffuse the light and protect the film. This diffusing disc then permits an *unfrosted colored lens* to be used and results in a sharp, clear legend... Note: *Photo Negative* is standard on oil-tight lenses.

When a *Glass Disc* is used, the legend is screened in either *negative or positive*. Where any high temperatures are involved with very little ventilation, an *Albalite glass (pyrex)* is used and the legend, after being screened, is baked so that it will not fade or peel because of the heat of the lamp. On application only.

*Note: A *white lens is translucent* and should never be specified for use with a disc. Where a white effect is desired, select either of the following: A *clear (colorless) lens* which permits the legend to be

visible at all times... or—a *clear lens with frosted back*, which imparts a hazy cast over the legend without destroying legibility. See Pages 3, 4, and 5 for Oil-Tight Assemblies equipped with discs.

DIALIGHT

A NORTH AMERICAN PHILIPS COMPANY

203 HARRISON PLACE • BROOKLYN, N.Y. 11237 • 212 497-7600 • TWX: 710-584-5487





PRESS-TO-TEST INDICATOR LIGHTS

MEET OR EXCEED REQUIREMENTS OF
MIL-L-7961B and MIL-L-3661

Provide Positive Safety Factors

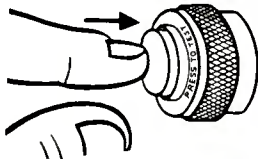

Positive safety factors are provided by patented built-in Press-To-Test Indicator Lights. Lamps can be checked—**instantly**—without removing lamps from the assembly.

A slight pressure on the lens holder of the Dialco assembly breaks the normal circuit and makes a test circuit, informing the operator as follows:

- 1—If the lamp **LIGHTS** when pressed in, it is proven satisfactory.
- 2—If the lamp **FAILS TO LIGHT** when pressed in, it is defective and must be replaced from the front of the panel.

Release of finger pressure restores the lens holder to operating position.

Press-To-Switch (4 terminal assemblies) is available with all indicator lights in this catalog. They are useful for remote control applications, as they permit closing the circuit to any local or remote device.

Typical Press-To-Test (3 terminal) and Press-To-Switch (4 terminal) circuit drawings are illustrated below.

Sub-Miniature, Miniature and Large Press-To-Test Indicator Lights are available with **Incandescent** or **Neon** lamps for mounting in 15/32", 5/8" and 1" clearance holes respectively. Only typical Incandescent Sub-Miniature and Miniature assemblies are listed in this catalog. Data on other Press-To-Test assemblies will be furnished on request.

Hot-stamped or engraved legends can be supplied on flat-end lenses only. Additional information will be furnished on request.

Typical
3 Terminal
Press-To-Test
Circuit

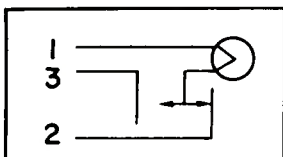

Typical
4 Terminal
Press-To-Switch
Circuit

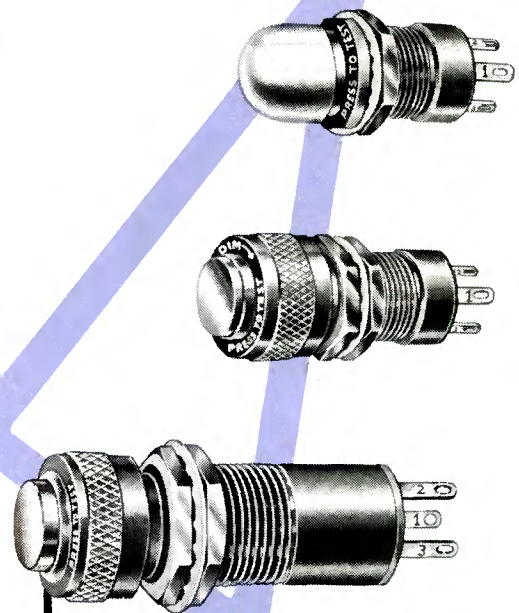
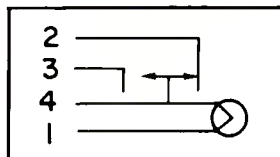

PATENTED SHUTTER DIMMING ACTION

The patented shutter-dimming device is available on most Press-To-Test Indicator Lights. By turning the knurled cap, the individual operator can regulate the brilliancy of the light from the indicator light to suit his needs under varying light conditions.



SHUTTERS OPEN
Maximum full direct
light beam



SHUTTERS ADJUSTED
Adjustable direct
light beam



SHUTTERS CLOSED
Minimum indirect
"halo" light

Standard dimmer action is "clockwise" to dim; it can be made "counter-clockwise" to dim, if desired.

Dialight Corporation reserves the right to make changes at anytime in order to improve design and to supply the best product possible.

Copyright ©1972 by the Dialight Corp., Brooklyn, N.Y. 11237

Printed in U.S.A.

DIALIGHT
MANUFACTURERS OF VISUAL INDICATORS

CORPORATION

60 STEWART AVENUE • BROOKLYN, N.Y. 11237 • 212 497-7600 • TWX: 710-584-5487

A NORTH AMERICAN PHILIPS COMPANY



SUB-MINIATURE INCANDESCENT PRESS-TO-TEST INDICATOR LIGHTS

MOUNT FROM BACK OF PANEL IN 15/32" CLEARANCE HOLE

MEET OR EXCEED REQUIREMENTS OF
MIL-L-7961B and MIL-L-3661

T-1 1/4 bulb
with midget
flange base. 

3 TERMINAL PRESS-TO-TEST or
4 TERMINAL PRESS-TO-SWITCH

MATERIALS AND FINISHES

- **Lens Cap:** Non-dimmer only.
 - **Mounting Bushing:** Aluminum, black anodize finish.
 - **Mounting and Flange Nuts:** Aluminum, black anodize finish.
 - **Internal-tooth Lockwasher:** Phosphor bronze, white nickel finish.
 - **Terminals:** Brass, hot tinned with elongated slot.
- "Press-To-Test" marking is die-stamped and filled on the flange nut of 3 terminal units only. No marking is furnished on the hex flange nut for 4 terminal indicator lights.

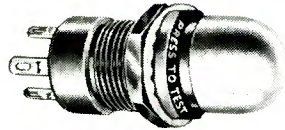

812-1030-0971-506

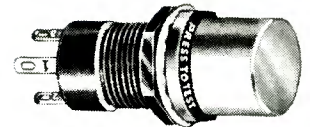

813-1030-1471-506

MANUFACTURER'S RATINGS

(Values given are approx.)

LAMP NO.	VOLTS	AMPERES	HOURS	CANDLE POWER
331	1.35	.06	5,000	.006
338	2.7	.06	6,000	.04
375	3.0	.015	20,000	.004
7332	5.0	.06	30,000	.05
*328	6.0	.20	1,000	.63
345	6.0	.04	10,000	.03
349	6.3	.20	5,000	.55
380	6.3	.04	20,000	.02
381	6.3	.20	20,000	.40
344	10.0	.014	25,000	.002
367	10.0	.04	10,000	.08
330	14.0	.08	1,500	.50
382	14.0	.08	15,000	.30
370	18.0	.04	10,000	.15
*327	28.0	.04	4,000	.34
**387	28.0	.04	7,000	.30

*Conforms to MS25237.

**MS18209 (BuShips)

- Ratings of lamps are taken from published catalogs of leading lamp manufacturers. Rated life is generally recognized as the 50% failure point of a group of lamps tested under static laboratory conditions, with the voltage closely regulated at the design value. This may not necessarily agree with the service of a lamp where the effects of temperature, vibration and voltage fluctuations may result in a shorter than rated life.

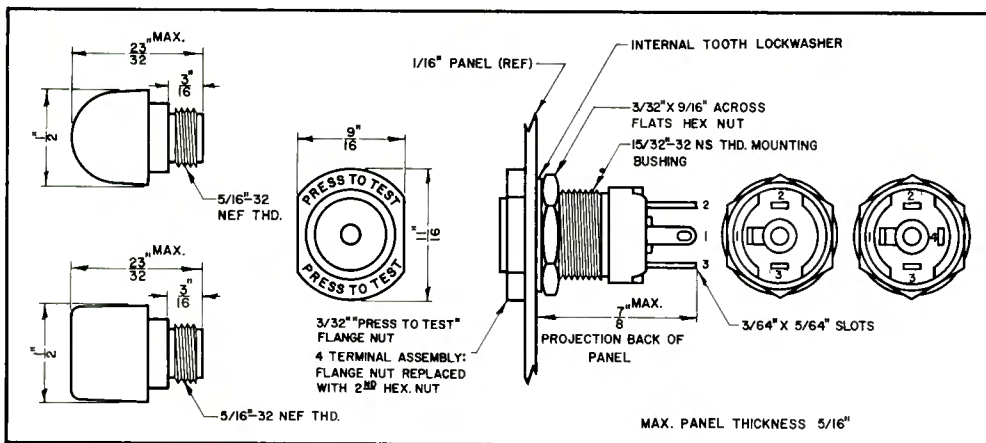

TRANSLUCENT LENS COLOR*	3 TERMINAL PRESS-TO-TEST ASSEMBLIES		4 TERMINAL PRESS-TO-SWITCH ASSEMBLIES		LENS CAP ASSEMBLIES TRANSLUCENT
	NEW CATALOG NUMBER	OLD CAT. NO.	NEW CATALOG NUMBER	OLD CAT. NO.	
White	812-1030-0975-506	VM910M-65	812-1130-0975-504	VM920M-65	812-0975
Red	812-1030-0971-506	VM910M-66	812-1130-0971-504	VM920M-66	812-0971
Green	812-1030-0972-506	VM910M-67	812-1130-0972-504	VM920M-67	812-0972
Yellow (Amber)	812-1030-0973-506	VM910M-68	812-1130-0973-504	VM920M-68	812-0973
Base Assembly	812-1030-09-506		808-1130-03-504		---

*To obtain transparent lens cap, change the third digit in code block 3 (-0971-) to "3". Example: 812-1030-0932-506.

TRANSLUCENT LENS COLOR*	3 TERMINAL PRESS-TO-TEST ASSEMBLIES		4 TERMINAL PRESS-TO-SWITCH ASSEMBLIES		LENS CAP ASSEMBLIES TRANSLUCENT
	NEW CATALOG NUMBER	OLD CAT. NO.	NEW CATALOG NUMBER	OLD CAT. NO.	
White	813-1030-1475-506	VM911M-5P5TL	813-1130-1475-504	VM920M-5P5TL	813-1475
Red	813-1030-1471-506	VM911M-6P5TL	813-1130-1471-504	VM920M-6P5TL	813-1471
Green	813-1030-1472-506	VM911M-7P5TL	813-1130-1472-504	VM920M-7P5TL	813-1472
Yellow (Amber)	813-1030-1473-506	VM911M-8P5TL	813-1130-1473-504	VM920M-8P5TL	813-1473
Base Assembly	812-1030-09-506		808-1130-03-504		---

*To obtain transparent lens cap, change the third digit in code block 3 (-1471-) to "3". Example: 813-1030-1431-506.

DIALIGHT
MANUFACTURERS OF VISUAL INDICATORS

CORPORATION

60 STEWART AVENUE • BROOKLYN, N.Y. 11237 • 212 497-7600 • TWX: 710-584-5487

A NORTH AMERICAN PHILIPS COMPANY

SUB-MINIATURE INCANDESCENT PRESS-TO-TEST INDICATOR LIGHTS



MILITARY STANDARD DRAWING MS25041 - 1 to 11

MEET OR EXCEED REQUIREMENTS OF
MIL-L-7961B and MIL-L-3661

MOUNT FROM BACK OF PANEL IN 15/32" CLEARANCE HOLE

MATERIALS AND FINISHES

- **Dimmer Cap:** Semi-blackout shutter.
- **Mounting Bushing and Lens Holder:** Aluminum, black anodize finish.
- **Mounting and Flange Nuts:** Aluminum, black anodize finish.
- **Internal-tooth Lockwasher:** Phosphor bronze, white nickel finish.
- **Terminals:** Brass, hot tinned with elongated slot.

Dimmer Lens Cap Assemblies: "Dim" with an arrow is die-stamped and filled on all Dimmer Lens Cap Assemblies: "Press-To-Test" marking is die-stamped and filled on all lens cap assemblies used with 3 terminal units.

Dimming



801-1030-0331-504

Non-Dimming



800-1030-0331-504

These assemblies accommodate T-1-3/4 bulb with midget flange base. See range of voltages on facing page.

CAP TYPE	TRANSPARENT LENS COLOR*	3 TERMINAL PRESS-TO-TEST ASSEMBLIES			4 TERMINAL PRESS-TO-SWITCH ASSEMBLIES		LENS CAP ASSEMBLIES FOR USE WITH	
		NEW CATALOG NUMBERS	OLD CAT. NOS.	MS NUMBER	NEW CATALOG NUMBERS	OLD CAT. NOS.	3 TERMINAL ASSEMBLIES	4 TERMINAL ASSEMBLIES
Dimming MECHANICAL SHUTTER semi-blackout	Clear (Colorless)	801-1030-0337-504	VM911M-1A	MS25041-1	809-1130-0337-504	VM920M-1	801-0337-500	809-0337-500
	Red	801-1030-0331-504	VM911M-2A	MS25041-2	809-1130-0331-504	VM920M-2	801-0331-500	809-0331-500
	Green	801-1030-0332-504	VM911M-3A	MS25041-3	809-1130-0332-504	VM920M-3	801-0332-500	809-0332-500
	Yellow (Amber)	801-1030-0333-504	VM911M-4A	MS25041-4	809-1130-0333-504	VM920M-4	801-0333-500	809-0333-500
	Blue	801-1030-0334-504	VM911M-10A	MS25041-10	809-1130-0334-504	VM920M-10	801-0334-500	809-0334-500
Non-Dimming	Clear (Colorless)	800-1030-0337-504	VM911M-5A	MS25041-5	808-1130-0337-504	VM920M-5	800-0337-500	808-0337-500
	Red	800-1030-0331-504	VM911M-6A	MS25041-6	808-1130-0331-504	VM920M-6	800-0331-500	808-0331-500
	Green	800-1030-0332-504	VM911M-7A	MS25041-7	808-1130-0332-504	VM920M-7	800-0332-500	808-0332-500
	Yellow (Amber)	800-1030-0333-504	VM911M-8A	MS25041-8	808-1130-0333-504	VM920M-8	800-0333-500	808-0333-500
	Blue	800-1030-0334-504	VM911M-11A	MS25041-11	808-1130-0334-504	VM920M-11	800-0334-500	808-0334-500
BASE ASSEMBLY		800-1030-03-504			808-1130-03-504			

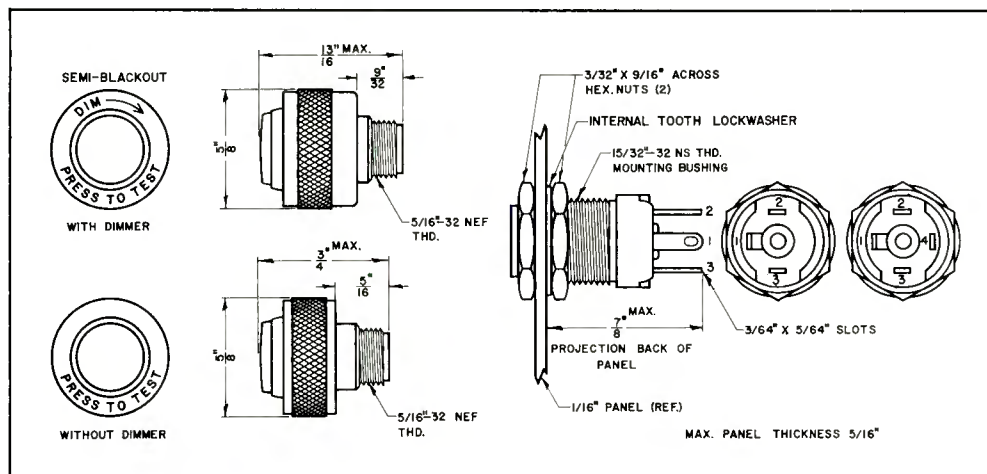

Order complete with lamps so that you will be assured of receiving the indicator light and correct lamp at one time for immediate use.

SAMPLES ON REQUEST—AT ONCE—NO CHARGE

DIALIGHT
MANUFACTURERS OF VISUAL INDICATORS

CORPORATION

60 STEWART AVENUE • BROOKLYN, N.Y. 11237 • 212 497-7600 • TWX: 710-584-5487

A NORTH AMERICAN PHILIPS COMPANY



MINIATURE INCANDESCENT PRESS-TO-TEST INDICATOR LIGHTS

MILITARY STANDARD DRAWING MS25331 - 1 to 8



T-3/4 bulb
with miniature
bayonet base.

(Values given
are approx.)

Non-Dimming

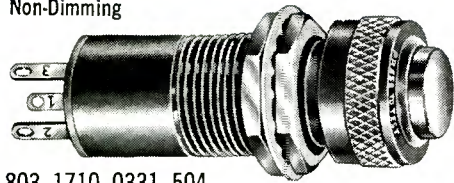

803-1710-0331-504

Dimming

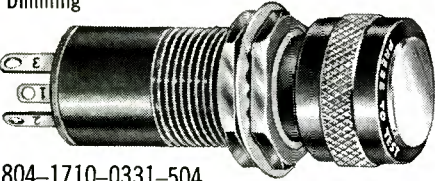

804-1710-0331-504

Non-Dimming



806-1710-0431-504

MEET OR EXCEED REQUIREMENTS OF
MIL-L-7961B and MIL-L-3661

MOUNT FROM BACK OF PANEL
IN 5/8" CLEARANCE HOLE

MATERIALS AND FINISHES

- **Dimmer Cap:** Semi-blackout shutter.
 - **Mounting Bushing and Lens Holder:** Aluminum, black anodize finish.
 - **Mounting and Flange Nuts:** Aluminum, black anodize finish.
 - **Internal-tooth Lockwasher:** Steel, cadmium plated with yellow iridescent chromate finish.
 - **Terminals:** Brass, hot tinned with elongated slot.
- Lens Cap Assembly Marking:** "Dim" with an arrow is die-stamped and filled on all Dimmer Lens Cap Assemblies. "Press-To-Test" marking is die-stamped and filled on all lens cap assemblies used with 3 terminal units only.

MANUFACTURER'S RATINGS

LAMP NO.	VOLTS	AMPS	WATTS	C.P.	LIFE (HRS)
49	2.0	0.06	0.12	0.04	1000
45	3.2	0.35	1.12	0.50	3000
47	6.3	0.15	0.95	0.52	3000
1847	6.3	0.15	0.95	0.38	3000
44	6.3	0.25	1.6	0.90	3000
1866	6.3	0.25	1.6	0.65	20000
755	6.3	0.15	0.95	0.33	50000
1891	14.0	0.24	3.4	2.0	500
1815	14.0	0.20	2.8	1.4	3000
756	14.0	0.08	1.1	0.31	50000
1819	28.0	0.04	1.1	0.34	1000
1829	28.0	0.07	1.9	1.0	1000
1820	28.0	0.10	2.8	1.6	1000
313	28.0	0.17	4.7	3.5	500
757	28.0	0.08	2.3	0.62	50000
1828	37.5	0.05	1.9	0.65	20000
1835	55.0	0.05	2.8	1.1	20000

C.P. is approximate mean spherical candlepower.

- Ratings of lamps are taken from published catalogs of leading lamp manufacturers.
- Rated life is generally recognized as the 50% failure point of a group of lamps tested under static laboratory conditions, with the voltage closely regulated at the design value. This may not necessarily agree with the service of a lamp where the effects of temperature, vibration and voltage fluctuations may result in a shorter than rated life.

CAP TYPE	TRANSPARENT LENS COLOR *	3 TERMINAL PRESS-TO-TEST ASSEMBLIES			4 TERMINAL PRESS-TO-SWITCH ASSEMBLIES		LENS CAP ASSEMBLIES FOR USE WITH	
		NEW CATALOG NUMBERS	OLD CAT. NOS.	MS NUMBER	NEW CATALOG NUMBERS	OLD CAT. NOS.	3 TERMINAL ASSEMBLIES	4 TERMINAL ASSEMBLIES
MECHANICAL SHUTTER semi-blackout	Clear (Colorless)	804-1710-0337-504	VM911-1A	MS25331-1	811-1810-0337-504	VM920-1	804-0337-500	811-0337-500
	Red	804-1710-0331-504	VM911-2A	MS25331-2	811-1810-0331-504	VM920-2	804-0331-500	811-0331-500
	Green	804-1710-0332-504	VM911-3A	MS25331-3	811-1810-0332-504	VM920-3	804-0332-500	811-0332-500
	Yellow (Amber)	804-1710-0333-504	VM911-4A	MS25331-4	811-1810-0333-504	VM920-4	804-0333-500	811-0333-500
	Blue	804-1710-0334-504	VM911-10A	---	811-1810-0334-504	VM920-10	804-0334-500	811-0334-500
NON-DIMMER	Clear (Colorless)	803-1710-0337-504	VM911-5A	MS25331-5	810-1810-0337-504	VM920-5	803-0337-500	810-0337-500
	Red	803-1710-0331-504	VM911-6A	MS25331-6	810-1810-0331-504	VM920-6	803-0331-500	810-0331-500
	Green	803-1710-0332-504	VM911-7A	MS25331-7	810-1810-0332-504	VM920-7	803-0332-500	810-0332-500
	Yellow (Amber)	803-1710-0333-504	VM911-8A	MS25331-8	810-1810-0333-504	VM920-8	803-0333-500	810-0333-500
	Blue	803-1710-0334-504	VM911-11A	---	810-1810-0334-504	VM920-11	803-0334-500	810-0334-500
NON-DIMMER WITH LARGE FACETED LENS	Red	806-1710-0431-504	VM911-9	---	806-1810-0431-504	VM920-9-431	806-0431-500	806-0431-500
BASE ASSEMBLY		803-1710-03-504	---	---	810-1810-03-504	---	---	---

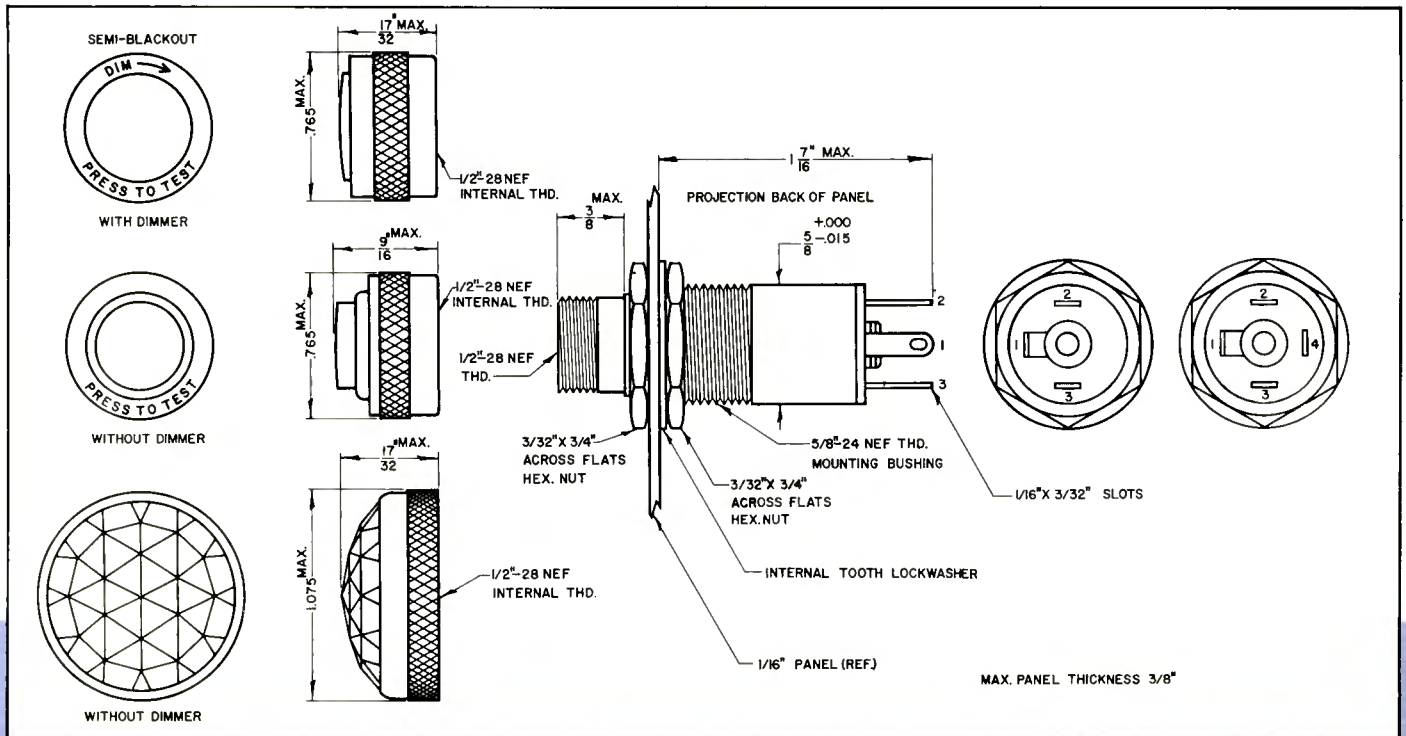



11
LED
DIODE LITES™

TO FIND ADDITIONAL LED VISUAL DISPLAY DATA:

LED Visual Display

Diode-Lite™ (LED)
Datalamp Cartridges
Ultra-Miniature Indicator Lights
Diode-Lite Readouts
Diode-Lite Switches

Located after Tab marked:

#11 LED DIODE-LITES™
5 ULTRA-MINIATURE INDICATOR LIGHTS
5 ULTRA-MINIATURE INDICATOR LIGHTS
#13 READOUTS
#14 SWITCHES

DIALIGHT

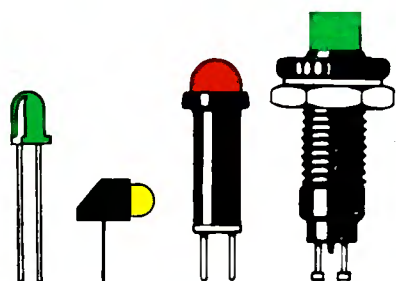

LED

Product Selector Guide

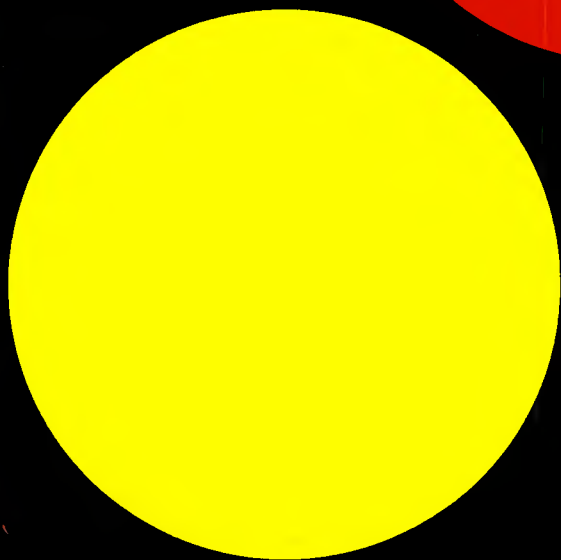
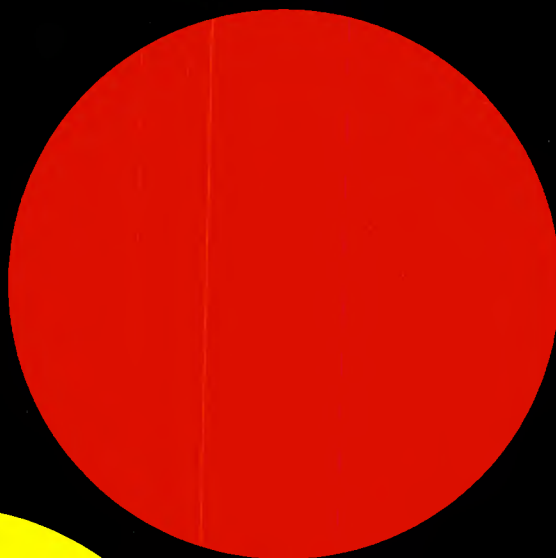

A NORTH AMERICAN PHILIPS COMPANY

CATALOG SG751
January 1975

LED Product SelectorGuide

table of contents

DESCRIPTION	PART OR SERIES NUMBER	PAGE NUMBER		
LIGHT SOURCES				
• LED Solid State Lamps	Red Diffused	521-9165	5-6	
	Clear Diffused	521-9166	5-6	
	Red Diffused	521-9167	5-6	
	Clear Diffused	521-9168	5-6	
	Red Diffused	521-9180	5-6	
	Clear Non-Diffused	521-9190	5-6	
	Red Diffused	521-9189	7-8	
	Red Diffused	521-9179	9-10	
	Red Diffused	521-9183	9-10	
	Clear Non-Diffused	521-9184	9-10	
	Red Diffused	521-9200	11-12	
	Red Diffused	521-9214	11-12	
	Green Non-Diffused	521-9202	13-14	
	Green Diffused	521-9203	13-14	
	Yellow Non-Diffused	521-9204	15-16	
	Yellow Diffused	521-9205	15-16	
	Green Diffused	521-9206	17-18	
	Yellow Diffused	521-9207	17-18	
	Red Non-Diffused	521-9185	19-20	
	Red Diffused	521-9186	19-20	
	Red Diffused	521-9195	19-20	
	Red Diffused	521-9215	21-22	
	Red Diffused	521-9216	21-22	
	Red Diffused	521-9217	23-24	
	• LED T 1 3/4 Lamps w/midget flange base	Red Diffused	521-9181	25-26
		Green Non-Diffused	521-9201	25-26
		Yellow Non-Diffused	521-9208	25-26
		Clear Non-Diffused	521-9223	25-26
Clear Non-Diffused		521-9222	25-26	
• LED Bi-Pin Lamps	Red Diffused	549-0101	27	
	Red Diffused	549-0104	27	
INDICATOR LIGHTS				
• LED Logic State/Fault Indicators	Red Diffused	547 Series	28	
	Red, Yellow, or Green Diffused	550 Series	29-30	
	Red Diffused	555 Series	31	
• LED Datalamp Cartridges	Red, Yellow or Green	507 Series	32-33	
• LED Indicator Lights	Red, Yellow or Green	249 Series	34	
	Red, Yellow or Green Diffused	558/559 Series	35-36	
• LED Status Indicator	Red, Green	556/557 Series	37-38	
OPTO-ISOLATORS	551-0002	39-42		
	551-0003	39-42		
STOCKING DISTRIBUTORS		back cover		

DIALIGHT

A NORTH AMERICAN PHILIPS COMPANY

203 HARRISON PLACE • BROOKLYN, N.Y. 11237 • 212 497-7600 • TWX: 710-584-5487

Immediate Action Reply Form

Please use this form to obtain additional information.

LED 1975

1 Yes, I'm interested in Diode-Lite (LED) visual displays. Please add my name to your mailing list.

2 Within the next 12 months, I expect to select, specify, buy: _____ est. annual usage _____

- Diode-Lite (LED) light sources _____
- Solid state lamp cartridges _____
- Solid state indicator lights _____
- Solid state logic state/fault indicator _____
- Solid state status indicators _____
- Opto-Isolators _____

3 I require more detailed information on this specific product:

_____ please print product name or
_____ catalog number(s)

4 My inquiry is for:
 a specific current application
 a possible future application
 reference use only

5 This application is the result of:
 new equipment or system design
 modification or redesign of existing equipment
 substitution of similar equipment

6 The above noted application will operate on:
Voltage: _____
Current: _____

7 For this application, about how many units will you require: _____

8 Please have Sales Representative phone me
 Factory Sales Engineer phone me,
for needed assistance

9 Please send me current price list

Comments: _____

Sketch Area

Name _____
Position _____ Dept. _____
Tel. _____ Ext. _____
Company _____
Street _____
City _____
State _____ Zip _____

Please fold, staple or seal and mail.

FOLD HERE

FOLD HERE

First Class
Permit No. 27572
Brooklyn, N.Y.

BUSINESS REPLY MAIL No postage stamp necessary if mailed in the United States

Postage Will Be Paid By

DIALIGHT

203 Harrison Place
Brooklyn, N.Y. 11288



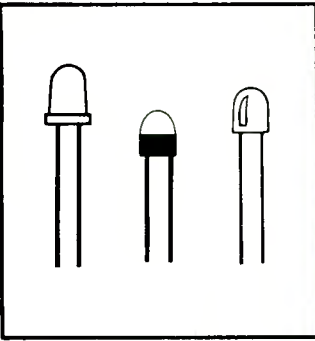

521 Series

DIAL-LITE[®]

GaAsP Solid State Lamps

521-9165; 521-9166; 521-9190

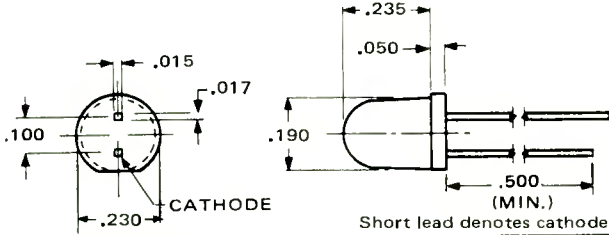

521-9167; 521-9168

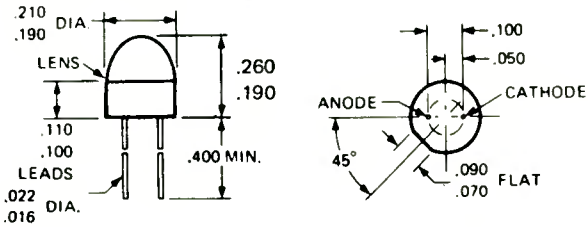

521-9180

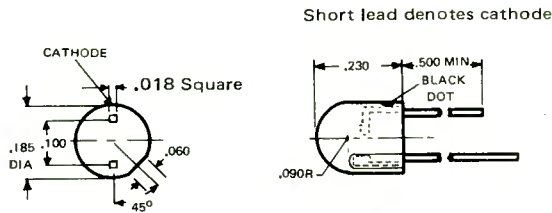

features

- High Luminous Intensity - 2.0 mcd @ 20 mA; exception: 521-9167 & 521-9168 - 1.0 mcd @ 20 mA.
- Low Cost
- Low Power Consumption - IC Compatible
- Vibration/Shock Resistant
- Solid State Reliability - Life Measured in Years
- Wide Viewing Angle
- High On/Off Contrast

These solid state lamps consist of a gallium arsenide phosphide semiconductor diode completely encapsulated in high grade plastic. The base has a flat on one side which gives the device an "antirotation" feature as well as indicating which lead is the cathode.

Maximum Ratings

Forward DC Current	50 mA
Reverse Voltage	3 Volts
Power Dissipation - Derate 4 mW/°C above 100°C	100 mW
Storage Temperature	-55°C to 150°C
Relative Humidity @ 85°C	85%
Solder Temperature for 5 seconds	260°C @ 0.1" from Seating Plane

Radiant Characteristics @ I_F = 20 mA (25°C)

Parameters	Typical		Units
	521-9165 521-9166 521-9180 521-9190	521-9167 521-9168	
Luminous Intensity	2.0	1.0	mcd (note 2)
Luminous Flux	1.35	1.35	mlumen
Wavelength @ Peak	665	665	nM
Spectral Line Width	25	25	nM
Rise and Fall Time	10	10	ns (note 1)
Angle of Half Intensity	35	35	degrees
Angle of 0.1 Intensity	85	85	degrees

- Notes: 1. Time for a 10%-90% of light intensity for step change in current
2. Measured on mechanical axis of package.

Electrical Characteristics (25°C)

Symbol	Parameters	Minimum	Typical	Maximum
V _F	Forward Voltage @ 20mA	-	1.7V	2.0V
BV _R	Reverse Breakdown Voltage @ 10 μA	3.0V	8.0V	-

Ordering Information

Part No.	Color
521-9165	Red Diffused
521-9166	Clear Diffused
521-9167	Red Diffused
521-9168	Clear Diffused
521-9180	Red Diffused
521-9190	Clear Non-Diffused

Printed in U.S.A.
Copyright 1974 by Dialight, Brooklyn, N.Y. 11237

Dialight reserves the right to make changes at anytime in order to improve design and to supply the best product possible.

DIALIGHT

A NORTH AMERICAN PHILIPS COMPANY

203 HARRISON PLACE • BROOKLYN, N.Y. 11237 • 212 497-7600 • TWX: 710-584-5487



521-9189

DIAL-LITE[®]

GaAsP Solid State Lamps

Miniature LED



ACTUAL SIZE

No. 521-9189 Red Diffused

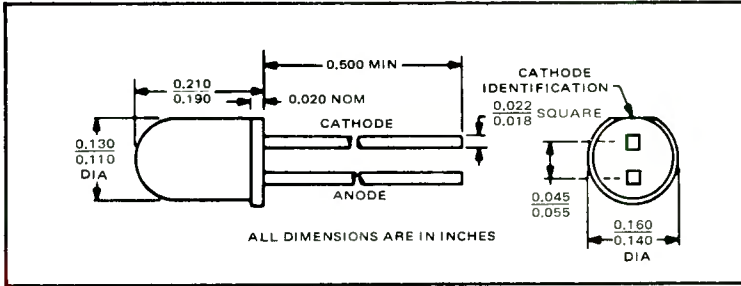

SPECIAL FEATURES

- High Luminous Intensity
- Low Cost
- Low Power Consumption – IC Compatible
- Vibration/Shock Resistant
- Solid State Reliability – Life Measured in Years
- Wide Viewing Angle

Applications

This device has many applications, which include panel lighting, film annotation, circuit status indicator, numeric or alphanumeric displays and visual indicators.

operating characteristics at 25°C ambient-air temperature

Parameter	Test Conditions	Min	Typ	Max	Unit
λ_p Wavelength at Peak Emission	$I_F = 20 \text{ mA}$	6300	6500	6700	Å
V_F Static Forward Voltage	$I_F = 20 \text{ mA}$		1.6	2	V
I_R Static Reverse Current	$V_R = 3V$		0.1		μA
I Luminous Intensity	$I_F = 20 \text{ mA}$.5	1.0		mcd

Maximum Ratings

Reverse Voltage at 25°C Ambient-Air Temperature	3V
Continuous Forward Current at (or below) 25°C Ambient-Air Temperature (See Note 1)	40 mA
Storage Temperature Range	-55°C to 100°C
Lead Temperature 1/16 Inch from Case for 5 Seconds	230°C

Note 1: Derate linearly to 70°C ambient-air temperature at the rate of 0.89 mA/°C.

DIALCO® GaAsP Solid State Lamps

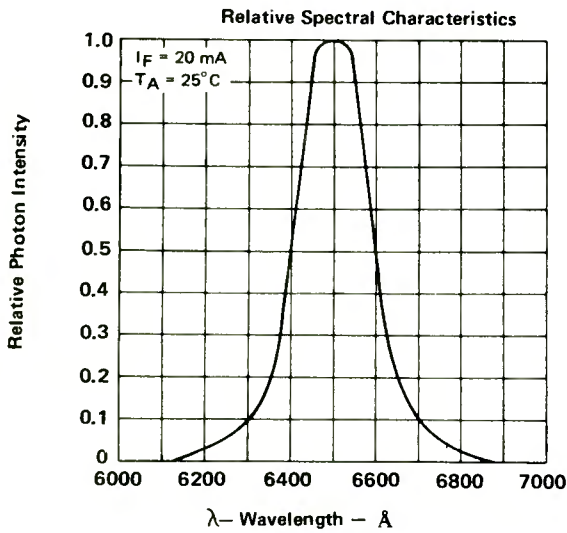

Figure 1

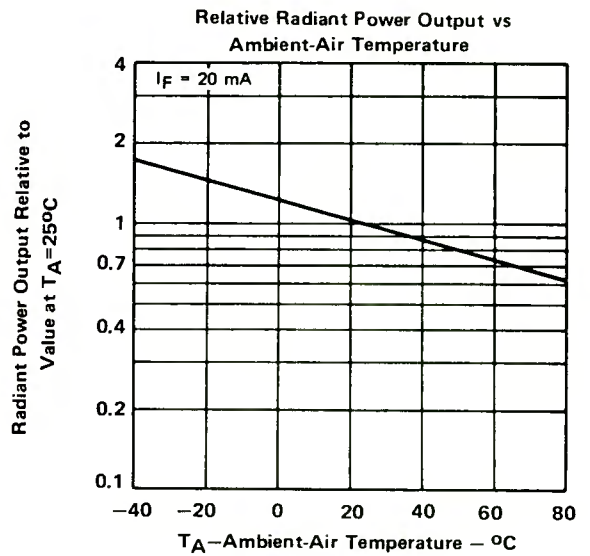

Figure 2

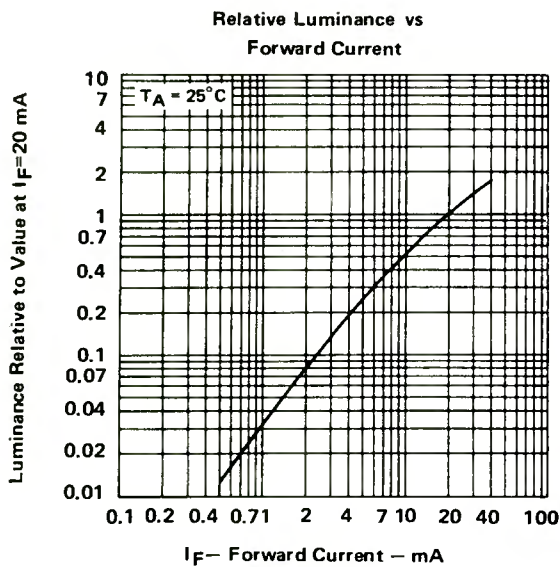

Figure 3

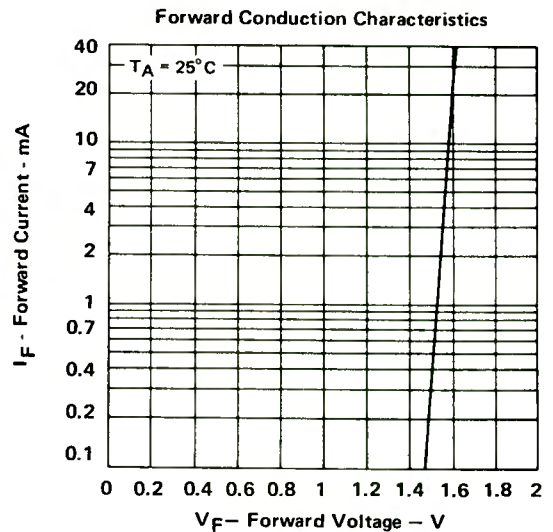
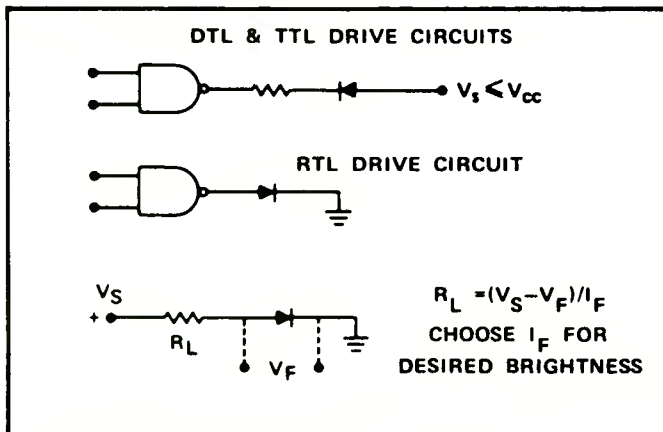

Figure 4

Typical Drive Circuits



Conversion Table

Read Across and Up	Candela/cm ²	ft-Lambert	Candela/ft ²
1 Candela/cm ² =	1	2.92 × 10 ³	9.29 × 10 ²
1 ft Lambert =	3.426 × 10 ⁻⁴	1	0.3183
1 Candela/ft ² =	1.076 × 10 ⁻³	π	1

Typical Resistor Values

DC Voltage	Current @ 10 mA	Current @ 20 mA
	R _L	R _L
3.6	200 Ω	100 Ω
5	330 Ω	180 Ω
6	430 Ω	220 Ω
10	820 Ω	390 Ω
14	1200 Ω	620 Ω
28	2700 Ω	1300 Ω



521-9179, 521-9183 & 521-9184

DIODE-LITE[®]

GaAsP Solid State Lamps

with or without integral current limiting resistor



ACTUAL SIZE

- No. 521-9179 Red Diffused – without resistor
- No. 521-9183 Red Diffused – with resistor
- No. 521-9184 Clear Non-Diffused – with resistor

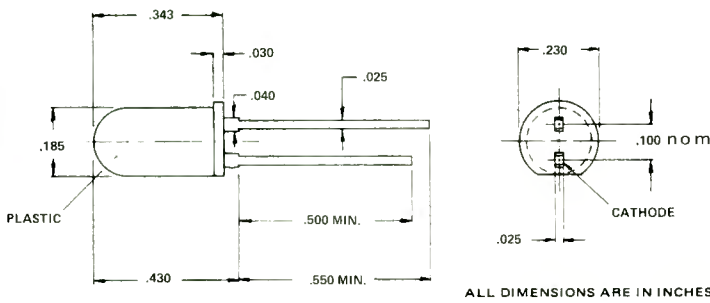

Features

- Integral current-limiting resistor
- IC compatible – 16 mA @ 5V (typical)
- High luminous intensity
- Wide viewing angle
- T-1 3/4 type package
- Long wire-wrappable leads
- Low cost
- Low power consumption
- Vibration/shock resistant
- Solid state reliability

Applications

These devices have many applications, which include panel lighting, circuit status indicator, numeric or alpha-numeric displays and visual indicators.

Maximum Ratings

Operating & Storage Temperature Range	-55°C to +100°C
Lead Soldering Temperature	230°C for 7 sec.

Operating Characteristics at $T_A = 25^\circ\text{C}$ (No. 521-9179 only)

SYMBOL	PARAMETERS	MIN.	TYP.	MAX.	UNITS	TEST CONDITIONS
I_V	LUMINOUS INTENSITY	0.8			mcd	$I_F = 20\text{ mA}$
$\lambda_p K$	WAVELENGTH		655		nm	MEASUREMENT AT PEAK
τ_s	SPEED OF RESPONSE		10		ns	
V_F	FORWARD VOLTAGE		1.6	2.0	V	$I_F = 20\text{ mA}$
BV_R	REVERSE BREAKDOWN VOLTAGE	3	10		V	$I_R = 10\ \mu\text{A}$

Operating Characteristics At $T_A = 25^\circ\text{C}$ (Nos. 521-9183 & 521-9184 only)

SYMBOL	PARAMETERS	MIN.	TYP.	MAX.	UNITS	TEST CONDITIONS
I_V	LUMINOUS INTENSITY	0.8			mcd	$V_F = 5\text{ V}$
$\lambda_p K$	WAVELENGTH		655		nm	MEASUREMENT AT PEAK
τ_s	SPEED OF RESPONSE		15		ns	
I_F	FORWARD CURRENT		15	20	mA	$V_F = 5\text{ V}$
BV_R	REVERSE BREAKDOWN VOLTAGE	3			V	$I_R = 10\ \mu\text{A}$

Printed in U.S.A.
Copyright 1974 by Diallight, Brooklyn, N.Y. 11237

Diallight reserves the right to make changes at anytime
in order to improve design and to supply the best product possible.

DIALIGHT
A NORTH AMERICAN PHILIPS COMPANY

203 HARRISON PLACE • BROOKLYN, N.Y. 11237 • 212 497-7600 • TWX: 710-584-5487

DIALCO[®] GaAsP Solid State Lamps

with or without integral current limiting resistor

521-9179 – without resistor

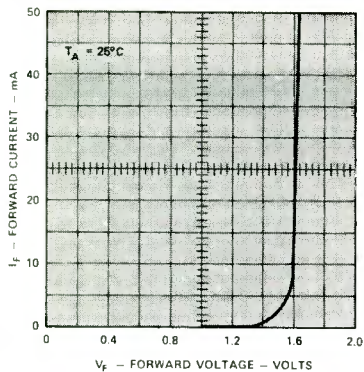

Typical Forward Current Versus Voltage Characteristic.

Figure 1.

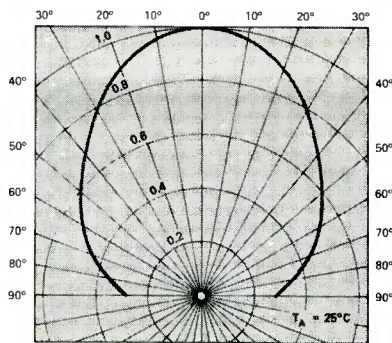

Typical Relative Luminous Intensity Versus Angular Displacement.

Figure 2.

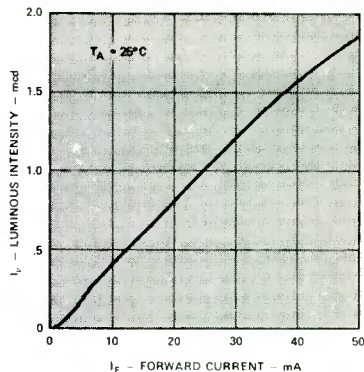

Luminous Intensity Versus Forward Current.

Figure 3.

521-9183, 521-9184 – with resistor

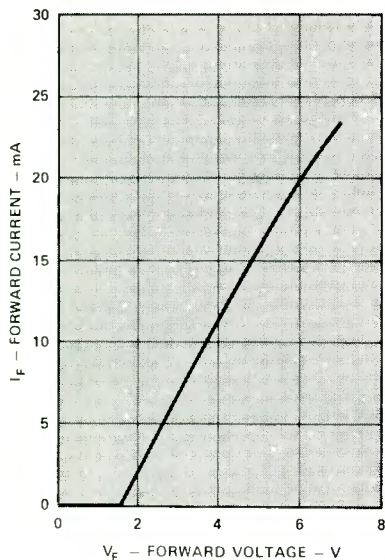

Typical DC Forward Current-Voltage Characteristic.

Figure 4.

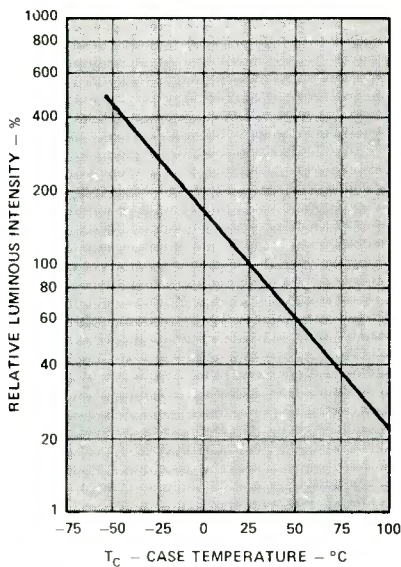

Relative Luminosity Versus Case Temperature.

Figure 5.

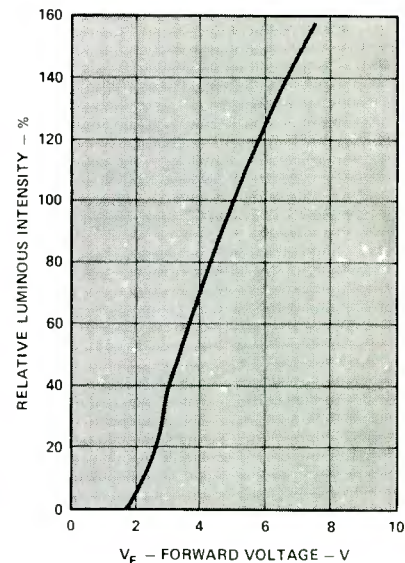

Relative Luminous Intensity Versus Voltage.

Figure 6.



521-9200 & 521-9214

DIODE-LITE[®] low cost GaAsP Solid State LED Lamp

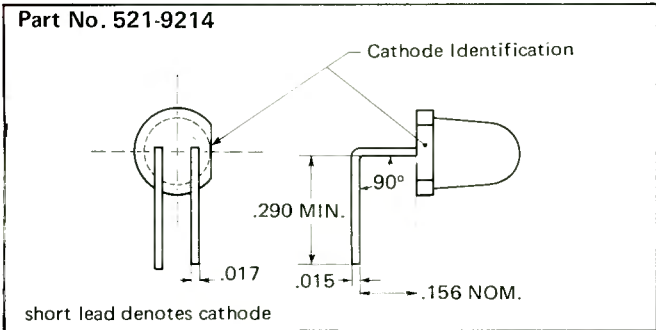
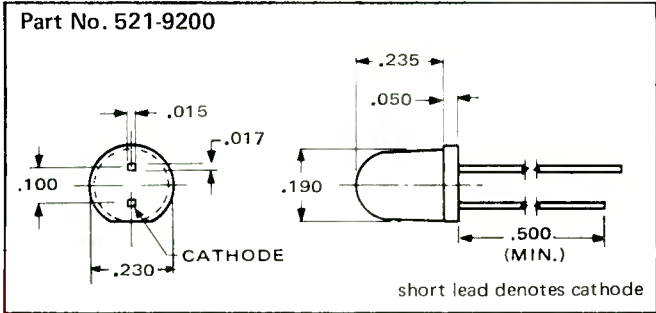
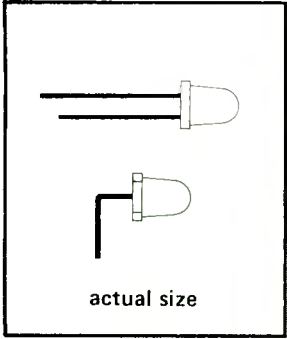

Features

- High Luminous Intensity - 2.0 mcd @ 20 mA
- Low Cost
- Low Power Consumption - IC Compatible
- Intense Large Area Light Source
- Vibration, Shock and High Temperature Resistant
- Solid State Reliability - Life Measured in Years
- High on/off Contrast
- Wide Viewing Angle

ABSOLUTE MAXIMUM RATINGS

Maximum Temperature and Humidity		
Junction Temperature		125° C
Storage Temperature		-55° C to +150° C
Lead Temperature (5 seconds)		260° C
Relative Humidity at 85° C		85%
Maximum Power Dissipation		
Total Dissipation		100 mW
Derate from 100° C		4.0 mW/° C
Maximum Voltage and Currents		
V _R	Reverse Voltage	3.0 V
I _F	Forward dc Current	50 mA
I _p	Forward Peak Current (1.0 μs pulse)	1.0 A

ELECTRICAL AND RADIANT CHARACTERISTICS (T_A = 25° C)

SYMBOL	CHARACTERISTIC	MIN	TYP	MAX	UNITS	TEST CONDITIONS
I _O	Axial Luminous Intensity	0.2	2.0		mcd	I _F = 20 mA
θ _{1/2}	Angle of Half Intensity		±35		degrees	I _F = 20 mA
V _F	Forward Voltage		1.9	3.0	V	I _F = 20 mA
BV _R	Reverse Voltage		8.0		V	I _R = 10 μA
λ _{pk}	Peak Wavelength		665		nm	I _F = 20 mA

Typical Resistor Values

DC Voltage	Current @ 10 mA		Current @ 20 mA	
	R _L		R _L	
3.6	200 Ω		100 Ω	
5	330 Ω		180 Ω	
6	430 Ω		220 Ω	
10	820 Ω		390 Ω	
14	1200 Ω		620 Ω	
28	2700 Ω		1300 Ω	

Printed in U.S.A.
Copyright 1974 by Dialight, Brooklyn, N.Y. 11237

Dialight reserves the right to make changes at anytime
in order to improve design and to supply the best product possible.

DIALIGHT
A NORTH AMERICAN PHILIPS COMPANY

203 HARRISON PLACE • BROOKLYN, N.Y. 11237 • 212 497-7600 • TWX: 710-584-5487

521-9200 & 521-9214



DIALCO® low cost

GaAsP Solid State LED Lamp

Typical Electrical Characteristic Curves

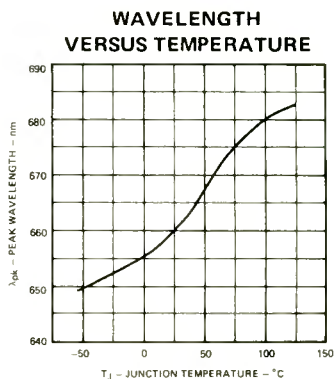
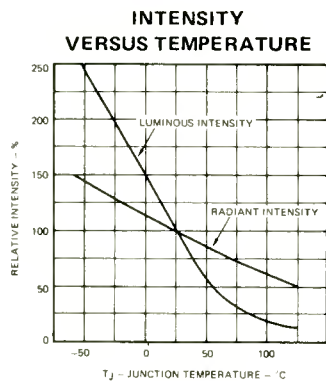
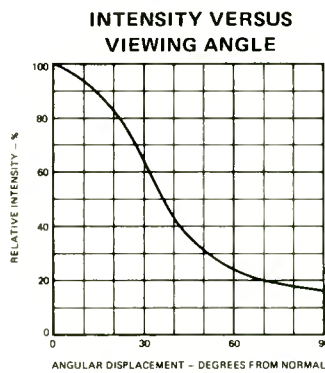
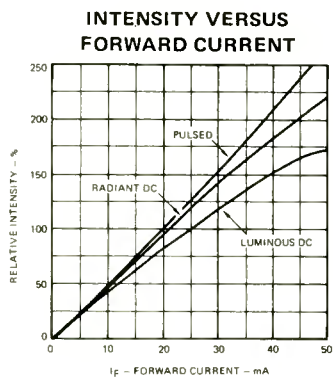
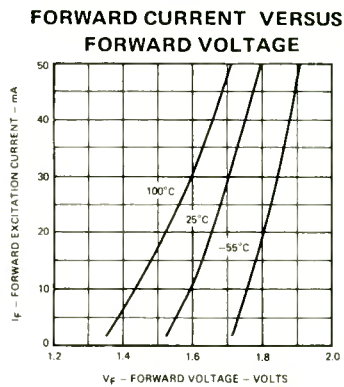
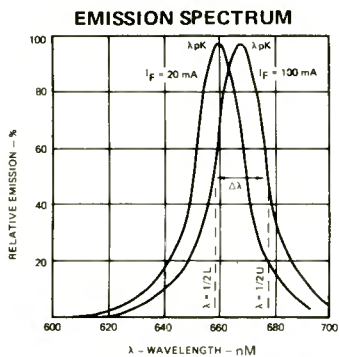



521-9202 and 521-9203 Green

DIALIGHT[®]

GaP Solid State Lamps



521-9202 – GREEN NON-DIFFUSED
521-9203 – GREEN DIFFUSED

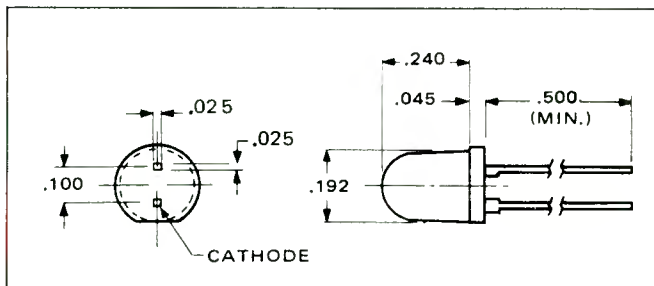

features

- High luminous intensity
- Identical in shape to our 521-9165 & 521-9200 RED LED
- Low cost
- Low power consumption – IC compatible
- Vibration/Shock resistant
- Solid state reliability – life measured in years
- Wide viewing angle
- T-1 $\frac{1}{2}$ type package
- Miniature size for maximum front panel density
- Snap-in clip available for easy panel mounting

Applications

This device has many applications, which include panel lighting, film annotation, circuit status indicator, numeric or alphanumeric displays and visual indicators.

Maximum Ratings at 25° C

Power Dissipation	112mW
Derate Linearly from 25° C	1.49mW/° C
Storage and Operating Temperature	-20° C to 100° C
Continuous Forward Current	40mA
Peak Pulse Current, 1 μ s Pulse 1% Duty Cycle	1A
Peak Reverse Voltage	5V

Operating Characteristics at 25° C Ambient-Air Temperature

Characteristics	Min.	Typical	Max.	Units	Conditions
Forward Voltage	1.8	2.0	2.8	V	I _f =10mA
Reverse Current	---	1	10	μ A	V _r =3.0V
Capacitance	---	100	---	pF	V=0
Peak Wave Length	---	565	---	nm	---
Spectral Line Half Width	---	30	---	nm	---
Luminous Intensity	521-9202	2.0	4.0	mcd	I _f =20mA
	521-9203	.8	2.0	mcd	I _f =20mA

Printed in U.S.A.
Copyright 1974 by Dialight, Brooklyn, N.Y. 11237

Dialight reserves the right to make changes at anytime in order to improve design and to supply the best product possible.

DIALIGHT
A NORTH AMERICAN PHILIPS COMPANY

203 HARRISON PLACE • BROOKLYN, N.Y. 11237 • 212 497-7600 • TWX: 710-584-5487

DOE-LITE[®] GaP Solid State Lamps

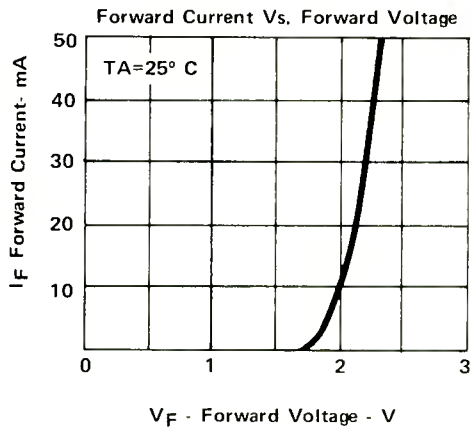
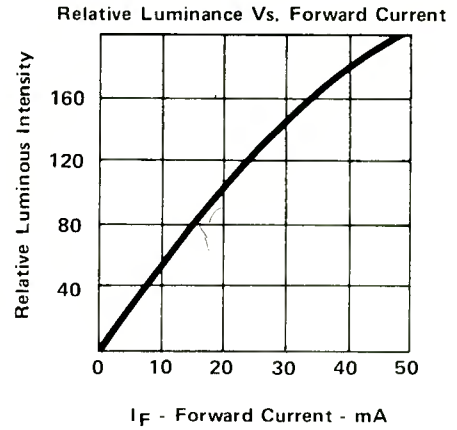
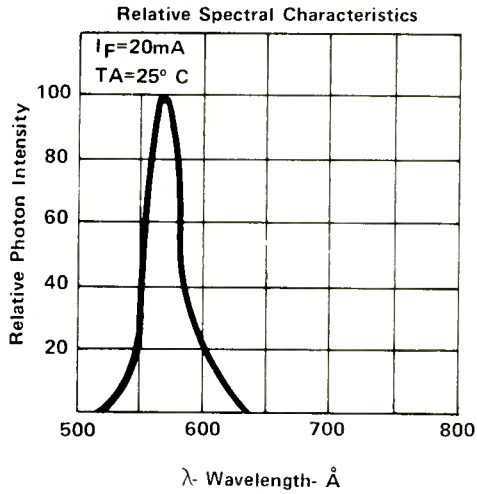

Typical Resistor Values

DC Voltage	Current @ 10 mA	Current @ 20 mA
	R_L	R_L
3.6	150 Ω	75 Ω
5	330 Ω	150 Ω
6	390 Ω	180 Ω
10	820 Ω	390 Ω
14	1200 Ω	620 Ω
28	2700 Ω	1300 Ω

Typical Drive Circuits

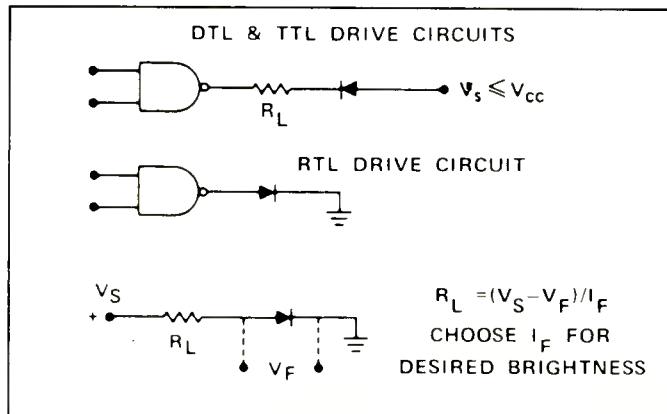



521-9204 and 521-9205 Yellow

DIALIGHT[®]

GaP Solid State Lamps

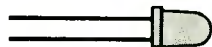

521-9204 – YELLOW NON-DIFFUSED
521-9205 – YELLOW DIFFUSED

features

- High luminous intensity – 2.0mcd
- Identical in shape to our 521-9165 RED LED
- Low cost
- Low power consumption – IC compatible
- Vibration/Shock resistant
- Solid state reliability – life measured in years
- Wide viewing angle
- T-1 $\frac{1}{4}$ type package
- Miniature size for maximum front panel density
- Snap-in clip available for easy panel mounting

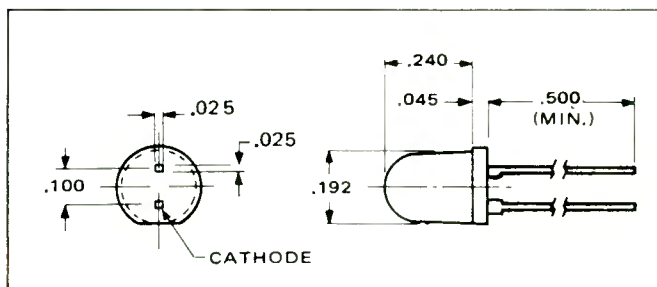

Applications

This device has many applications, which include panel lighting, film annotation, circuit status indicator, numeric or alphanumeric displays and visual indicators.

Maximum Ratings at 25° C

Power Dissipation	112mW
Derate Linearly from 25° C	1.49mW/° C
Storage and Operating Temperature	-20° C to 100° C
Continuous Forward Current	40mA
Peak Pulse Current, 1 μ s Pulse 1% Duty Cycle	1A
Peak Reverse Voltage	5V

Operating Characteristics at 25° C Ambient-Air Temperature

Characteristics	Min.	Typical	Max.	Units	Conditions
Forward Voltage	1.8	2.0	2.4	V	I _f =10mA
Reverse Current	---	1	10	μ A	V _r =3.0V
Capacitance	---	100	---	pF	V=0
Peak Wave Length	---	580	---	nm	---
Spectral Line Half Width	---	30	---	nm	---
Luminous Intensity	521-9204	2.0	4.0	mcd	I _f =20mA
	521-9205	.8	2.0	mcd	I _f =20mA



DIALCO® DIAL-LITE® GaP Solid State Lamps

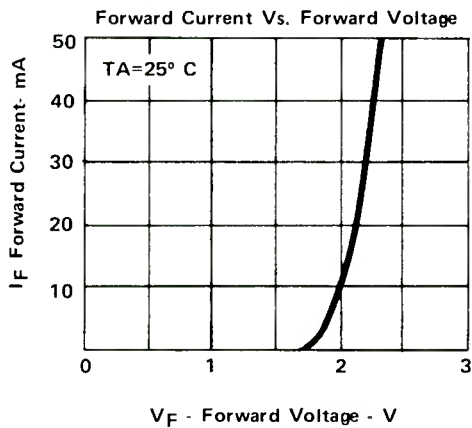
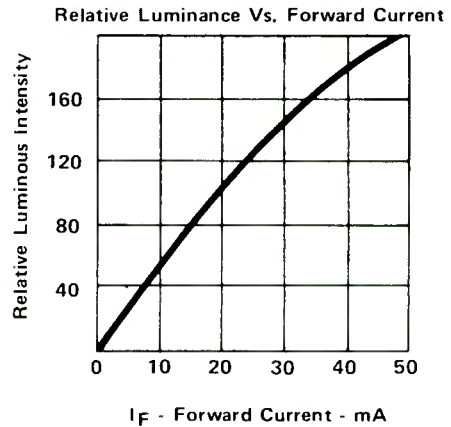
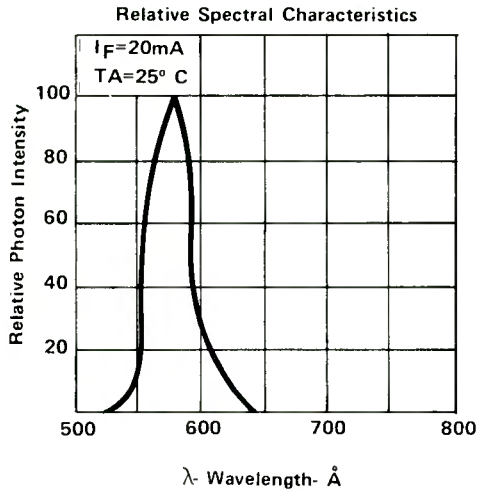

Typical Resistor Values

DC Voltage	Current @ 10 mA	Current @ 20 mA
	R_L	R_L
3.6	150 Ω	75 Ω
5	330 Ω	150 Ω
6	390 Ω	180 Ω
10	820 Ω	390 Ω
14	1200 Ω	620 Ω
28	2700 Ω	1300 Ω

Typical Drive Circuits

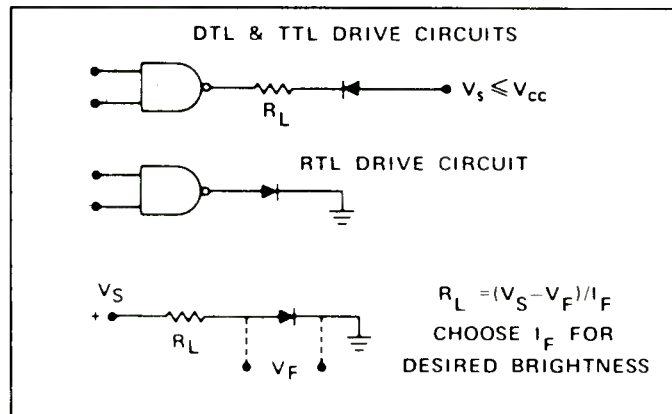



521-9206 (Green) & 521-9207 (Yellow)

DIALIGHT® GaP Solid State Lamps Miniature LED

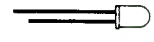

ACTUAL SIZE

No. 521-9206 Green Diffused
No. 521-9207 Yellow Diffused

features

- High luminous intensity
- Identical in shape to our 521-9189 RED LED
- Low cost
- Low power consumption – IC compatible
- Vibration/Shock resistant
- Solid state reliability – life measured in years
- Wide viewing angle
- T-1 type package
- 10 mA operation for typical brightness
- Miniature size for maximum front panel density

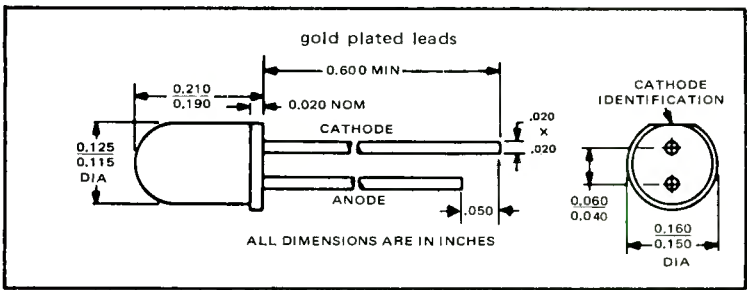

Applications

This device has many applications, which include panel lighting, film annotation, circuit status indicator, numeric or alphanumeric displays and visual indicators.

Maximum Ratings

Power Dissipation	112mW
Derate Linearly from 25° C	1.49mW/° C
Storage and Operating Temperature	-20° C to 100° C
Continuous Forward Current	40mA
Peak Pulse Current, 1 μs Pulse 1% Duty Cycle	1A
Peak Reverse Voltage	5V

Operating Characteristics at 25° C Ambient-Air Temperature

Characteristics	Min.	Typical		Max.		Units	Conditions
		Green	Yellow	Green	Yellow		
Forward Voltage	1.8	2.0	1.9	2.8	2.4	V	I _f =10mA
Reverse Current	—	1	1	10	10	μA	V _r =3.0V
Capacitance	—	100	100	—	—	pF	V=0
Peak Wave Length	—	560	580	—	—	nm	—
Spectral Line Half Width	—	30	30	—	—	nm	—
Luminous Intensity	.6	1.5	1.5	—	—	mcd	I _f =10mA

Printed in U.S.A.
Copyright 1974 by Dialight, Brooklyn, N.Y. 11237

Dialight reserves the right to make changes at anytime in order to improve design and to supply the best product possible.



203 HARRISON PLACE • BROOKLYN, N.Y. 11237 • 212 497-7600 • TWX: 710-584-5487

A NORTH AMERICAN PHILIPS COMPANY

521-9206 (Green) & 521-9207 (Yellow)



DIALCO® DIAL-LITE® GaP Solid State Lamps

Miniature LED

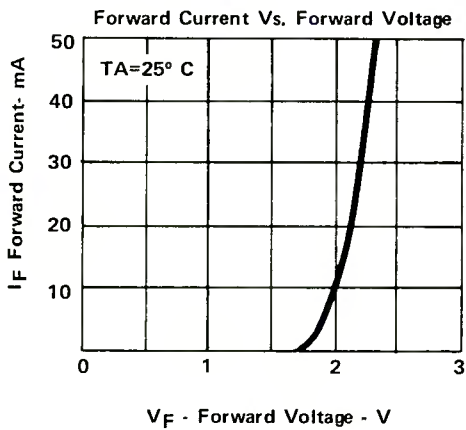
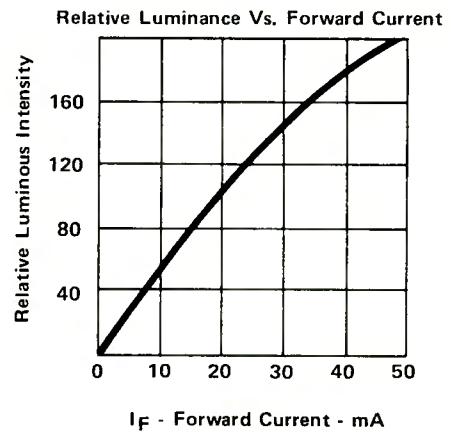
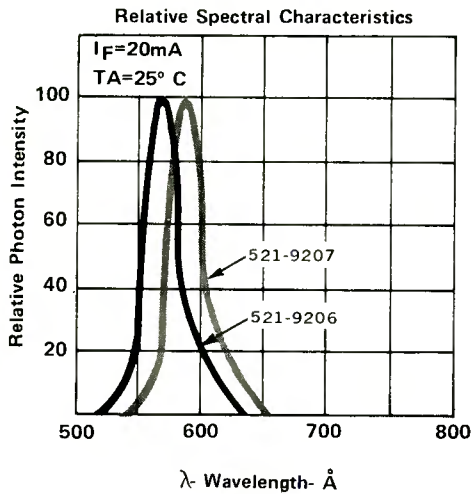

Typical Resistor Values

DC Voltage	Current @ 10 mA	Current @ 20 mA
	R_L	R_L
3.6	150 Ω	75 Ω
5	330 Ω	150 Ω
6	390 Ω	180 Ω
10	820 Ω	390 Ω
14	1200 Ω	620 Ω
28	2700 Ω	1300 Ω

Typical Drive Circuits

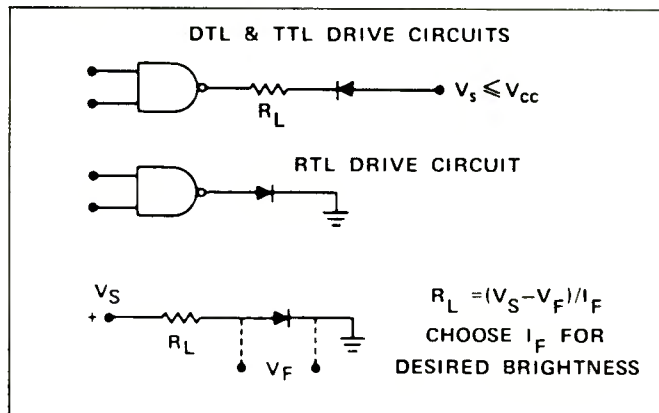



521-9185, 521-9186 & 521-9195

DIODE-LITE[®]

GaAsP Solid State Lamps

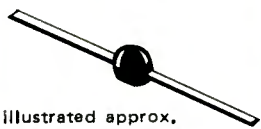

Illustrated approx.
2 times actual size

521-9185, 521-9186

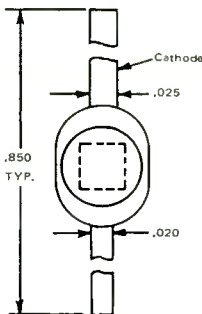
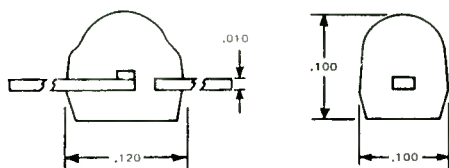

521-9195

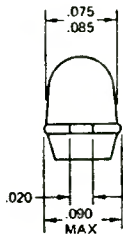
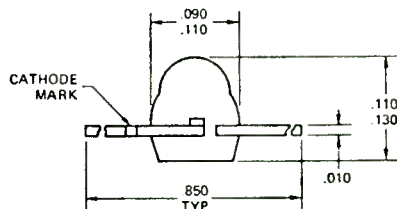

No. 521-9185 Red Non-Diffused
No. 521-9186 Red Diffused
No. 521-9195 Red Diffused

Features

- High Luminous Intensity: (No. 521-9185) – 750 foot lamberts @ 20 mA; – (No. 521-9186) – 0.8 mcd (typical) @ 20 mA; – (No. 521-9195) – 0.4 mcd (typical) when operated at 3 mA; 3.0 mcd (typical) when operated at 20 mA.
- Low Cost
- Low Power Consumption – Operates from 5V IC logic supply
- Small Size
- Solid State Reliability – Life Measured in Years
- Vibration/Shock Resistant
- Optimum packaging design

This DIODE-LITE – Series is intended for high volume usage in array and indicator light applications. The major advantages of these light sources are high luminance at lower current, long life and low cost.

Maximum Ratings

Forward DC Current	40 mA
Reverse Voltage	3.0V
Power dissipation-(Derate 1.1 mW/°C above 25°C)	80 mW
Storage and Operating Temperature Range	-55°C to +100°C

Applications

Any consumer product requiring a visual indicator, i.e. status indicators on PC boards, clocks, calculators, cameras, etc.

Operating Characteristics @ 25°C Ambient Air Temperature.

PARAMETER	521-9185†		521-9186*		521-9195			UNITS
	TEST CONDITION	TYP.	MAX.	TEST CONDITION	MIN.	TYP.	MAX.	
* Luminous intensity	I _f = 20 mA	0.8		I _f = 20 mA	2	3		mcd
				I _f = 3 mA	0.2	0.4		mcd
† Luminance (Brightness)	I _f = 20 mA	750		I _f = 3 mA	100	200		ft-L
† Current to produce 50 ft-L		2	10					mA
Forward voltage	I _f = 20 mA	1.6	2.0	I _f = 3 mA		1.6	2.0	V
Reverse current	V _R = 3.0V	0.100		V _R = 3.0V		0.15	10.0	NA
Capacitance	V=0	90		V=0		20		pF
Rise & Fall Time		1.0				1.0		n SEC.

Printed in U.S.A.
Copyright 1974 by Dialight, Brooklyn, N.Y. 11237

Dialight reserves the right to make changes at anytime in order to improve design and to supply the best product possible.

DIALIGHT
A NORTH AMERICAN PHILIPS COMPANY

203 HARRISON PLACE • BROOKLYN, N.Y. 11237 • 212 497-7600 • TWX: 710-584-5487

DIODE-LITE[®] GaAsP Solid State Lamps

521-9185; 521-9186 only

Figure 1

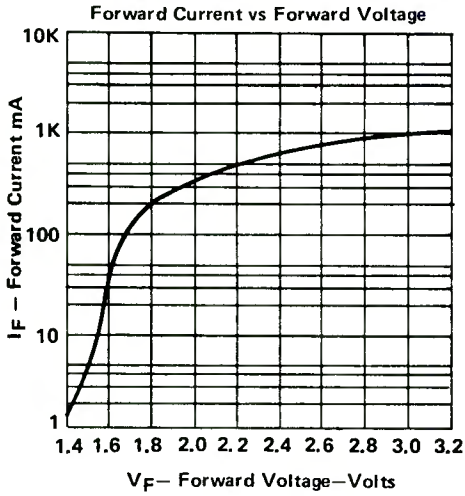

521-9185; 521-9186 only

Figure 3

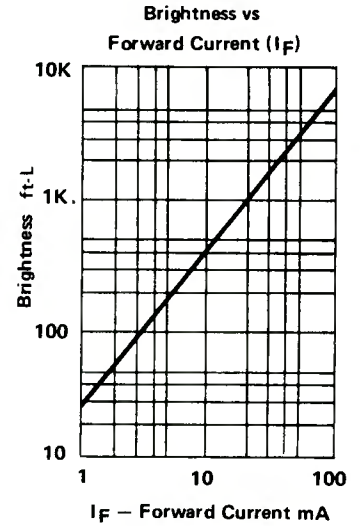
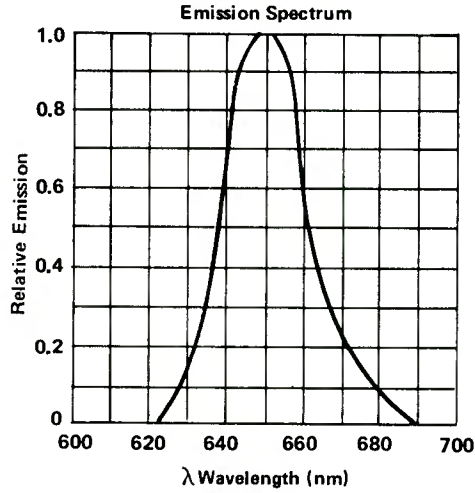

Figure 2



521-9195 only

Figure 4

Radiated Power

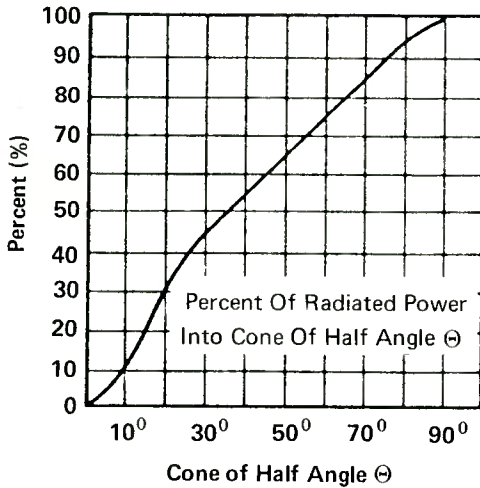

521-9195 only

Figure 5

Radiation Intensity Spatial Distribution

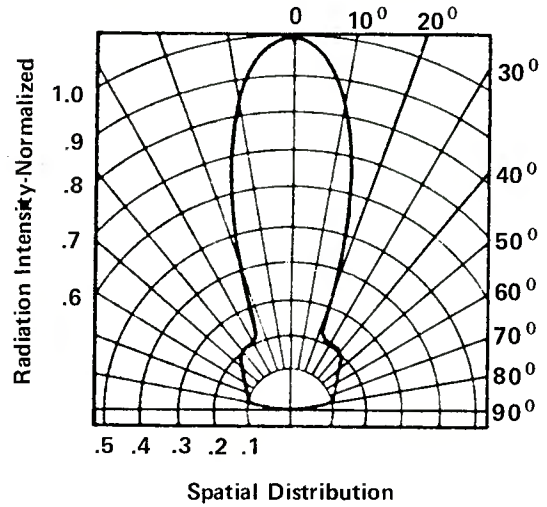

Typical Drive Circuits

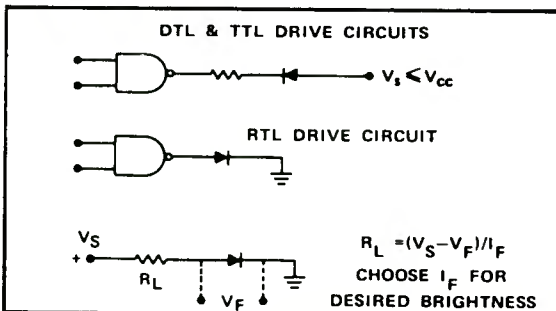

Typical Resistor Values

DC Voltage	Current @ 10 mA	Current @ 20 mA
	R_L	R_L
3.6	200 Ω	100 Ω
5	330 Ω	180 Ω
6	430 Ω	220 Ω
10	820 Ω	390 Ω
14	1200 Ω	620 Ω
28	2700 Ω	1300 Ω

521-9215 & 521-9216

DIALITE[®] GaAsP Solid State Lamps

with or without integral current limiting resistor

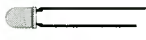

actual size

No. 521-9215 Red Diffused – with resistor
 No. 521-9216 Red Diffused – without resistor

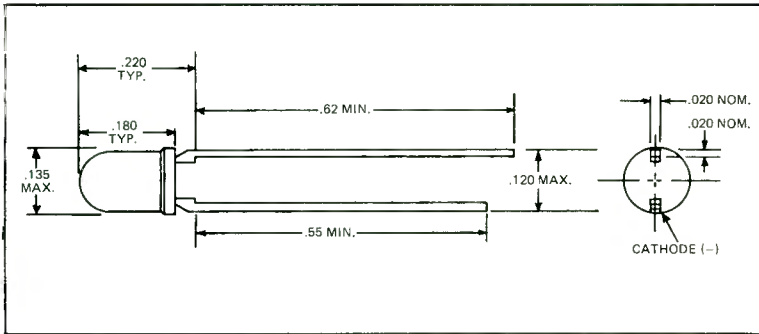

Features

- 521-9215 with Integral current-limiting resistor
- 521-9215 IC compatible –16 mA @ 5V (typical)
- 521-9216 low cost
- High luminous intensity
- Wide viewing angle
- T-1 type package
- Low power consumption
- Vibration/shock resistant
- Solid state reliability

Applications

These devices have many applications, which include panel lighting, circuit status indicator, numeric or alpha-numeric displays and visual indicators.

Maximum Ratings (521-9215 only)

DC Forward Voltage (Derate linearly to 5V @ 100°C)	7.5V
Reverse Voltage	7.0V
Storage Temperature	-55°C to 100°C
Operating Temperature	-55°C to 100°C
Lead Soldering Temperature	230°C for 7 sec.

Maximum Ratings (521-9216 only)

Forward DC Current	50 mA
Peak Forward Current (1 μsec Pulse, 300 pps)	1 A
DC Power Dissipation (Derate linearly from 50°C at 1.6 mW/°C)	100 mW
Storage Temperature	-55°C to 100°C
Operating Temperature	-55°C to 100°C
Lead Soldering Temperature	230°C for 7 sec.

Operating Characteristics at T_A = 25°C (No. 521-9215 only)

SYMBOL	PARAMETERS	MIN.	TYP.	MAX.	UNITS	TEST CONDITIONS
I _V	LUMINOUS INTENSITY	0.3	0.8		mcd	V _F = 5V
λ _D K	WAVELENGTH		655		nm	MEASUREMENT AT PEAK
τ _s	SPEED OF RESPONSE		15		ns	
I _F	FORWARD CURRENT		16	20	mA	V _F = 5V
BV _R	REVERSE BREAKDOWN VOLTAGE	3			V	I _R = 10 μA

Operating Characteristics at T_A = 25°C (No. 521-9216 only)

SYMBOL	PARAMETERS	MIN.	TYP.	MAX.	UNITS	TEST CONDITIONS
I _V	LUMINOUS INTENSITY	0.3	0.8		mcd	I _F = 20 mA
λ _D K	WAVELENGTH		655		nm	MEASUREMENT AT PEAK
τ _s	SPEED OF RESPONSE		10		ns	
V _F	FORWARD VOLTAGE		1.6	2.0	V	I _F = 20 mA
BV _R	REVERSE BREAKDOWN VOLTAGE	3			V	I _R = 100 μA

Typical Resistor Values for use with 521-9216

DC Voltage	Current @ 10 mA	Current @ 20 mA
	R _L	R _L
3.6	200 Ω	100 Ω
5	330 Ω	180 Ω
6	430 Ω	220 Ω
10	820 Ω	390 Ω
14	1200 Ω	620 Ω
28	2700 Ω	1300 Ω

DIALCO[®] DODE-LITE[®] GaAsP Solid State Lamps

with or without integral current limiting resistor

521-9215 – with resistor

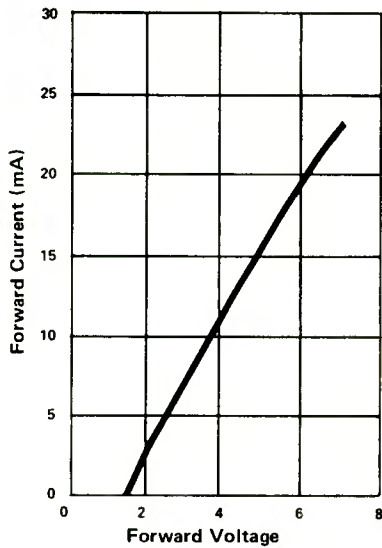

Forward Current vs. Forward Voltage

Figure 1.

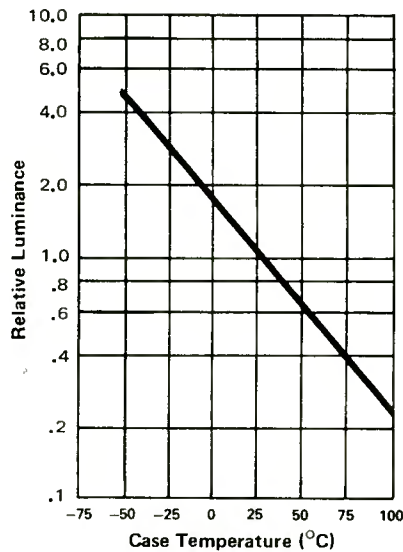

Relative Luminance vs. Case Temperature

Figure 2.

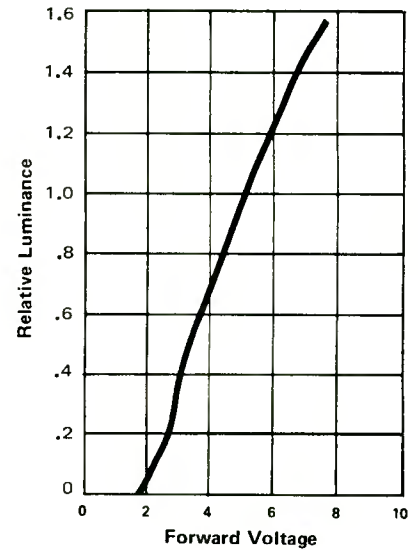

Relative Luminance vs. Forward Voltage

Figure 3.

521-9216 – without resistor

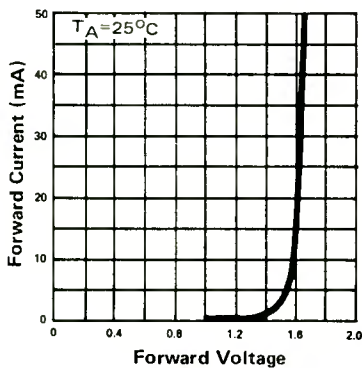

Forward Conductance Characteristics

Figure 4.

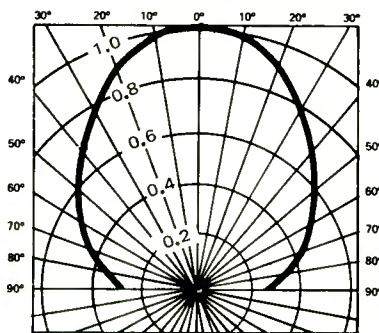

Typical Relative Luminance vs. Angular Displacement

Figure 5.

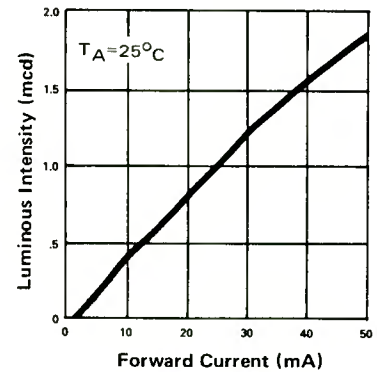

Luminous Intensity vs. Forward Current

Figure 6.

521-9217

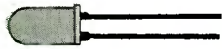

actual size

DIALIGHT® low cost GaAsP Solid State LED Lamp

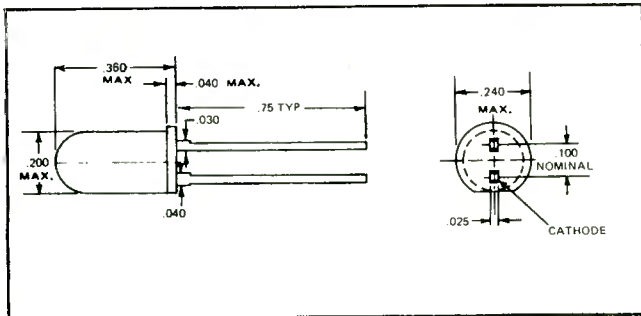

No. 521-9217 Red Diffused

Features

- High Luminous Intensity
- Low Cost
- Low Power Consumption - IC Compatible
- Intense Large Area Light Source
- Vibration, Shock and High Temperature Resistant
- Solid State Reliability - Life Measured in Years
- High on/off Contrast
- Wide Viewing Angle

Maximum Ratings

Power Dissipation (Derate 2.0 mW/°C above 25°C)	180mW
Forward DC Current	70mA
Operating & Storage Temperature Range	-40°C to +100°C
Lead Soldering Temperature	260°C for 5 sec.

Typical Resistor Values

DC Voltage	Current @ 10 mA	Current @ 20 mA
	R_L	R_L
3.6	200 Ω	100 Ω
5	330 Ω	180 Ω
6	430 Ω	220 Ω
10	820 Ω	390 Ω
14	1200 Ω	620 Ω
28	2700 Ω	1300 Ω

Operating Characteristics at $T_A = 25^\circ\text{C}$

SYMBOL	PARAMETERS	MIN.	TYP.	MAX.	UNITS	TEST CONDITIONS
I_V	LUMINOUS INTENSITY	0.4	0.8		mcd	$I_F = 20 \text{ mA}$
λ_{PK}	WAVELENGTH		660		nm	MEASUREMENT AT PEAK
τ_s	SPEED OF RESPONSE		50		ns	
V_F	FORWARD VOLTAGE		1.8	2.0	V	$I_F = 20 \text{ mA}$
BV_R	REVERSE BREAKDOWN VOLTAGE	5			V	$I_R = 100 \mu\text{A}$

DIALCO *DIALCO-LITE*® low cost

GaAsP Solid State LED Lamp

Light Intensity vs Ambient Temperature

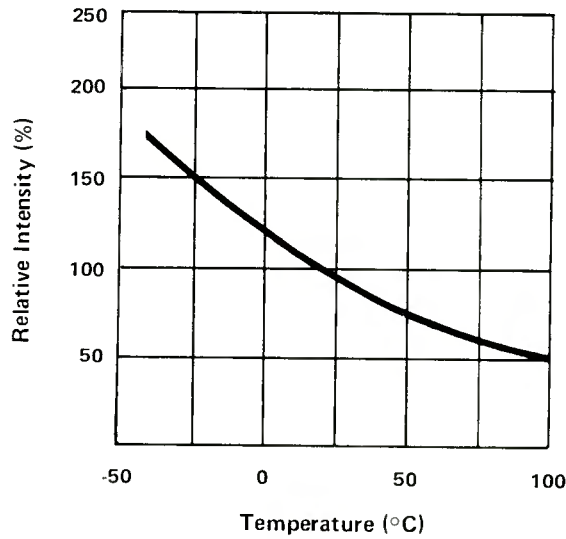

Forward Current (I_F) vs Forward Voltage (V_F)

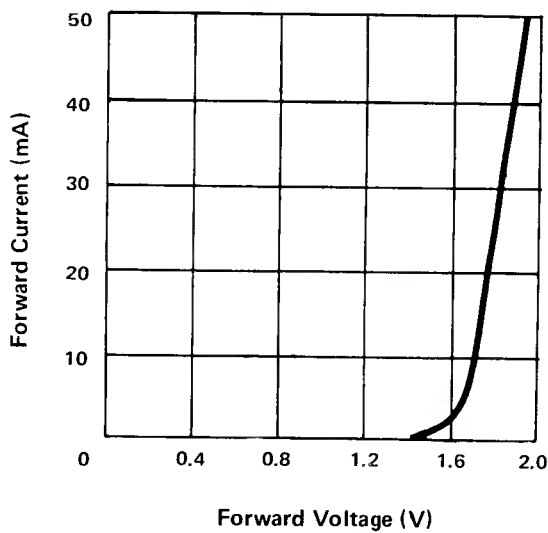

Light Intensity vs Forward Current (I_F)

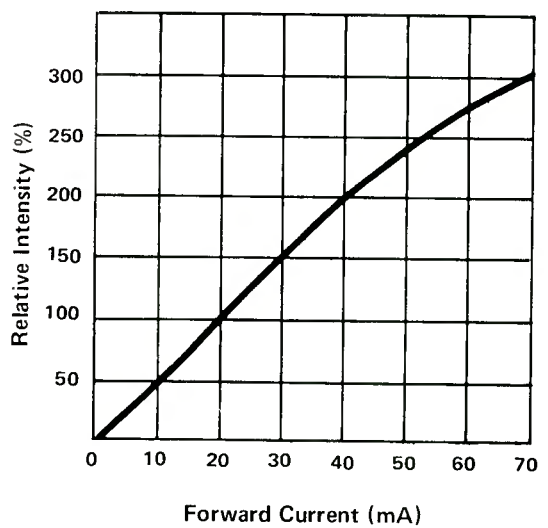

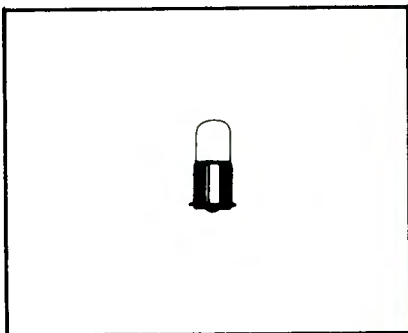

DIODE-LITE[®]

T-1 3/4 LED Lamp with Midget Flange Base

- 521-9181 Red – Red Diffused
- 521-9201 Green – Green Non-Diffused
- 521-9208 Yellow – Yellow Non-Diffused
- † 521-9222 Red – Clear Non-Diffused
- 521-9223 Red – Clear Non-Diffused

† With integral resistor for 5V operation.

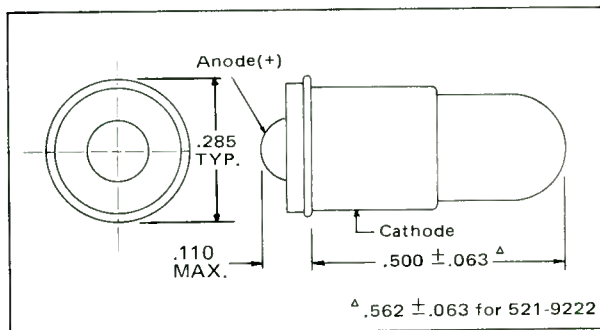

Features

- High luminous intensity
- Low cost
- Low power consumption - IC compatible
- Vibration/shock resistant
- Solid state reliability - life measured in years
- Wide viewing angle
- Interchangeable with midget flange base incandescent lamps when used with appropriate series resistor. See table of typical resistor values on reverse side.

These based Diode-Lite lamps are available in red, green and yellow, and are suggested for use in indicator light assemblies with transparent lens caps only.

Ordering Information

Part Number	Lens Color	Fwd. Volt (typ)	Maximum Fwd. Current	(typ) Luminous Intensity	Wave-Length
☆ 521-9181	Red Diffused	1.7 @ I _F =20mA	50 mA.	2 mcd	665 nm
☆ 521-9201	Green Non-Diffused	2.0 @ I _F =10mA	40 mA.	2 mcd	565 nm
☆ 521-9208	Yellow Non-Diffused	2.0 @ I _F =10mA	40 mA.	2 mcd	580 nm
† 521-9222	Clear Non-Diffused	5.0 @ 15 mA	20 mA.	2 mcd	655 nm
☆ 521-9223	Clear Non-Diffused	1.7 @ I _F =20mA	50 mA.	2 mcd	665 nm

☆ Require external series resistor. See table for suggested values.
† Includes integral resistor for 5V operation.

(over)

DIALCO® DIAL-LITE® T-1 3/4 LED Lamp

with Midget Flange Base



521-9181
521-9223

Relative Luminance Vs. Forward Current

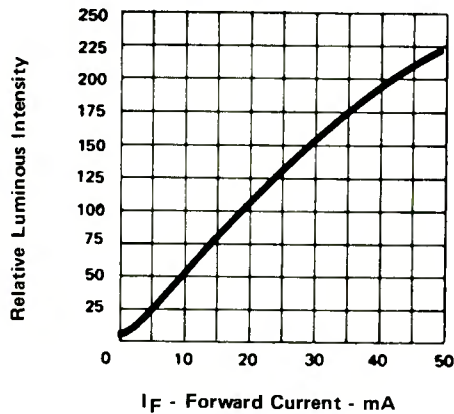

521-9181 521-9223

Typical Resistor Values

DC Voltage	Current @ 10 mA	Current @ 20 mA
	R_L	R_L
3.6	200 Ω	100 Ω
5	330 Ω	180 Ω
6	430 Ω	220 Ω
10	820 Ω	390 Ω
14	1200 Ω	620 Ω
28	2700 Ω	1300 Ω

521-9201
521-9208

Relative Luminance Vs. Forward Current

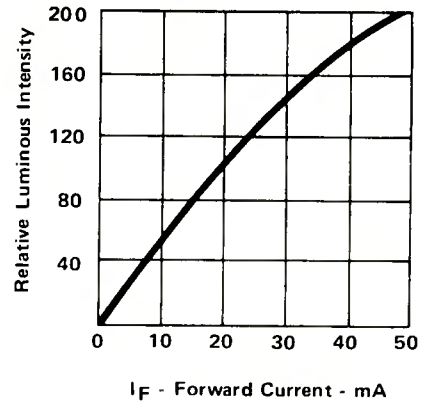

521-9201 521-9208

Typical Resistor Values

DC Voltage	Current @ 10 mA	Current @ 20 mA
	R_L	R_L
3.6	150 Ω	75 Ω
5	330 Ω	150 Ω
6	390 Ω	180 Ω
10	820 Ω	390 Ω
14	1200 Ω	620 Ω
28	2700 Ω	1300 Ω

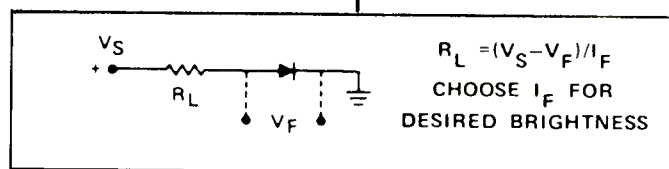

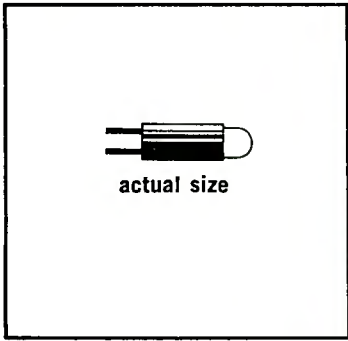

549 series

DIODE-LITE[®] LED Bi-PIN Lamp

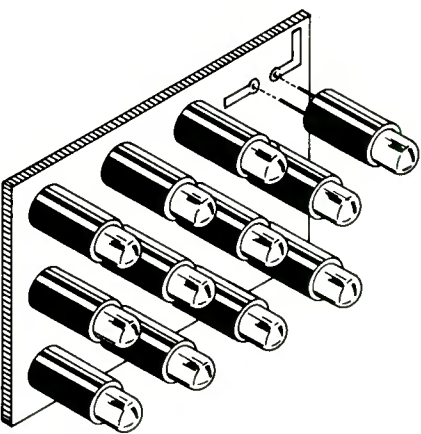

typical PC board mounting illustrating dense packaging

549-0101 Red Diffused
549-0104 Red Diffused

Features

- Directly interchangeable with a T-1 3/4 Bi-Pin based incandescent lamp.
- Gallium Arsenide Phosphide light source.
- Compact design permits dense packaging.
- High reliability—life measured in years.
- Polarity identified.
- Immune to shock and vibration.
- Can be driven directly from DTL and TTL logic.
- Molded case available in standard black
- Gold plated terminals.
- Rigid pin construction.

The LED Bi-Pin lamp was developed to be directly interchangeable with its T-1 3/4 incandescent equivalent. The LED combined with a built-in resistor (for current limiting) and pins molded in a plastic case substantially improves the life and reliability over an incandescent lamp. A wide range of operating voltages and currents is possible by using the 549-0101 with the appropriate external resistor.

The light emitting diode in the assembly is of Gallium Arsenide Phosphide material. The lens is red diffused.

The terminations are .025" square leads with gold plating. The rigidity of the leads provides for easy insertion and removal from a socket, or for direct mounting on a PC board. The gold plating is an aid in soldering.

The molded case includes a flat on one side for indexing to establish correct polarity.

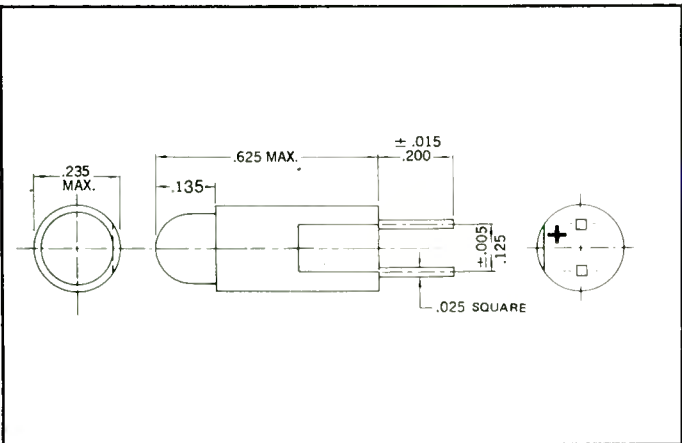

Ordering Information

Catalog Numbers	Volts	mA
549-0101	1.7	*
549-0104	5	16 Δ

* Requires external resistor. Maximum forward DC current 50 mA. Typical operating current 20 mA.
Δ For higher brightness can be operated at 6V @ 20 mA.



547 Series **DIALIGHT**

LED logic state/fault indicator

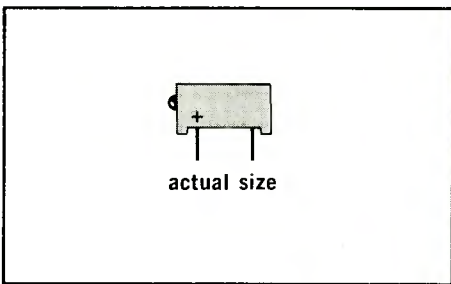

actual size

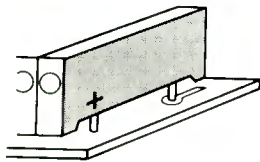

PC board mounted

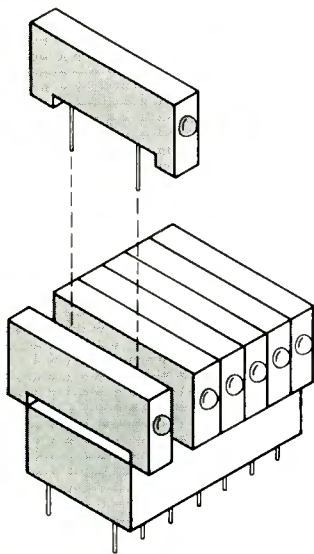

DIP socket mounted
(using Dialight 501-0702-009 socket)

The LED logic state/fault indicator is an extremely versatile device and lends itself to a wide range of applications. Typically it might be used as a fault indicator for trouble shooting complex printed circuit cards.

Other possible applications

- Logic state indicator.
- Binary data display—permits stacking so that multiple functions can be displayed.
- Indicator light.

Features

- Gallium Arsenide Phosphide LED.
- Can be driven directly from DTL and TTL logic.
- Very low power consumption.
- High reliability—life measured in tens of years.
- Polarity identified.
- Compact design permits dense packaging. Units can be mounted 10 units to the inch.
- Pin spacing compatible with DIP sockets.
- Built-in series resistor.
- Gold plated leads permit ease of soldering—units are designed to allow soldering onto PC boards.
- Black case enhances contrast ratio.
- Available in range of voltages and currents.

Ordering Information

Catalog Numbers	Volts	mA
547-2001	1.7*	
547-2002	3.6	20
547-2007	5	3
547-2003	5	6
547-2004	5**	16
547-2005	10	14
547-2006	14	10

* Requires External Resistor. Maximum DC forward current 50 mA. Typical operating current 20 mA.
 ** For higher brightness can be operated at 6V @ 20 mA.

Printed in U.S.A.
 Copyright 1974 by Dialight, Brooklyn, N.Y. 11237

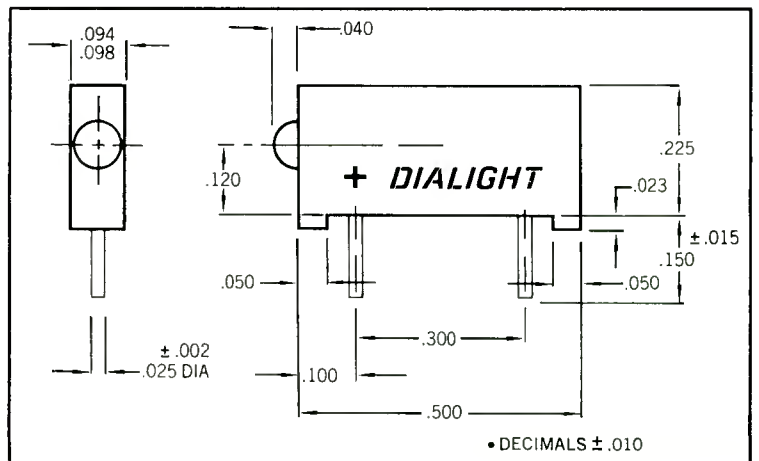

Dialight reserves the right to make changes at anytime in order to improve design and to supply the best product possible.

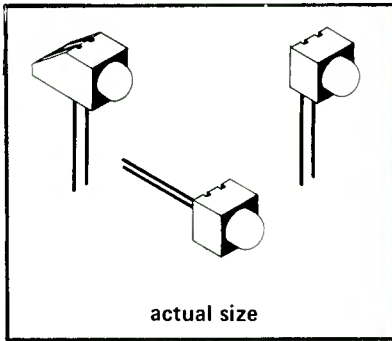

actual size

550 series

DIAL-LITE®

LED logic state/fault indicators with Green, Yellow or Red LED

550-0204—GREEN
550-0304—YELLOW
550-0404—RED
*550-0504—RED with integral resistor for operation at 5V.

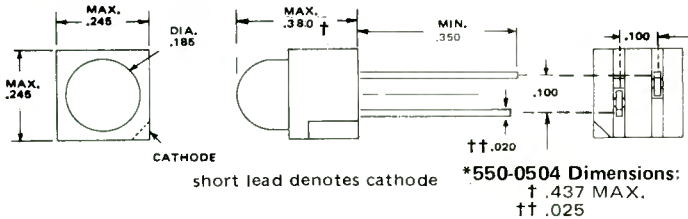

550-0205—GREEN
550-0305—YELLOW
550-0405—RED
*550-0505—RED with integral resistor for operation at 5V.

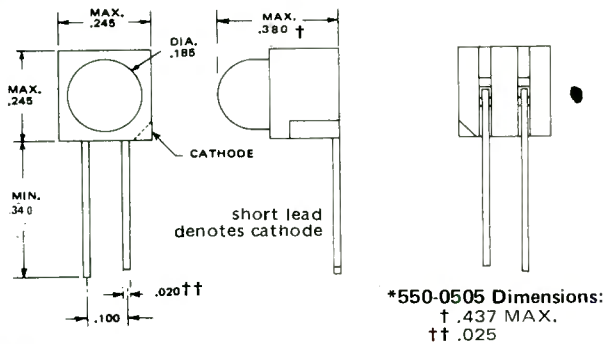

550-0206—GREEN
550-0306—YELLOW
550-0406—RED
*550-0506—RED with integral resistor for operation at 5V.

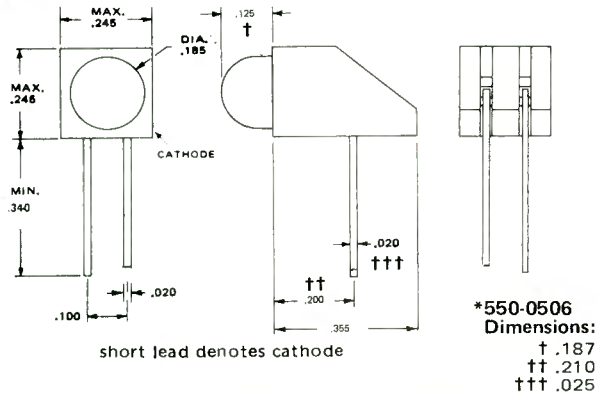

Features

- High Luminous Intensity
- Solid State light source
- Available with Red, Green or Yellow LEDs
- Wide Viewing Angle
- IC Compatible
- Low Power Consumption
- High Reliability - Life measured in years
- Designed for ease in circuit board assembly
- Black case enhances contrast ratio
- Vibration and Shock Resistant
- Designed to allow for high density packaging
- Low cost
- Polarity Identified
- Available with or without integral resistor

Applications

- Indicator light
- Panel illumination
- Logic State Indicator
- Binary data display - permits stacking so that multiple functions can be displayed.

The 550 series indicators are designed for use in a wide variety of applications where solid state compatibility and ease in assembly and mounting are required. Such applications could include P/C board and panel mounting. A large LED lamp with a high light level makes these units convenient for back panel illumination.

The 550-XX06 series is designed for installations where a more rigid assembly is required.

The 550-050X series with integral resistor for operation at 5V, 15 mA is available in red only.

550 series



LED logic state/fault indicators †

Maximum Ratings	Red	Green and Yellow
Forward DC Current	50 mA	40 mA
Reverse Voltage	3 Volts	3 Volts
Power Dissipation—Derate 1.3mW/° C above 25° C	25°C — 100 mW	Derate 1.49mW/° C above 25° C 112 mW
Storage Temperature	-40°C to 100°C	-20°C to 100°C
Operating Temperature	-40°C to 100°C	-20°C to 100°C
Relative Humidity @ 85°C	85%	85%
Solder Temperature for 5 seconds	250°C @ 0.1" from Seating Plane	250°C @ 0.1" from Seating Plane

Electrical characteristics (25°C)

Symbol	Parameters	Minimum	Typical	Maximum
V_F	Forward Voltage @ 20 mA Red	---	1.8V	2.0V
	Green & Yellow	---	2.2V	2.8V
B_{VR}	Reverse Breakdown Voltage @ 10 μ A	3.0V	8.0V	---

Typical Resistor Values 550-04--- (Red)

DC Voltage	Current @ 10 mA	Current @ 20 mA
	R_L	R_L
3.6	200 Ω	100 Ω
5	330 Ω	180 Ω
6	430 Ω	220 Ω
10	820 Ω	390 Ω
14	1200 Ω	620 Ω
28	2700 Ω	1300 Ω

Typical Resistor Values

550-02--- (Green) and 550-03--- (Yellow)

DC Voltage	Current @ 10 mA	Current @ 20 mA
	R_L	R_L
3.6	150 Ω	75 Ω
5	330 Ω	150 Ω
6	390 Ω	180 Ω
10	820 Ω	390 Ω
14	1200 Ω	620 Ω
28	2700 Ω	1300 Ω

Radiant Characteristics @ $I_F = 20$ mA (25°C)

Parameters	Red	Green & Yellow	Units
	Typical	Typical	
Luminous Intensity	2.0	1.0	mcd (note 2)
Wavelength @ Peak	650	*565	nM
Spectral Line Width	25	30	nM
Rise and Fall Time	10	10	ns (note 1)
Angle of Half Intensity	35	35	degrees
Angle of 0.1 Intensity	85	85	degrees

Typical Drive Circuits

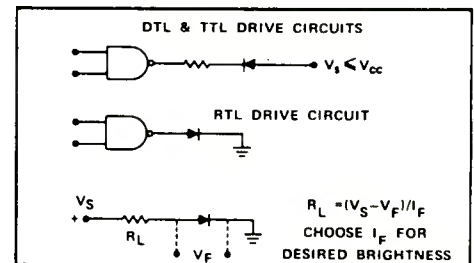

*Wavelength not applicable for yellow.

Notes:

1. Time for a 10%–90% of light intensity for step change in current
2. Measured on mechanical axis of package.

† All ratings for devices, w/o integral resistor.

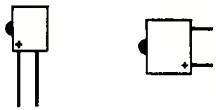

actual size

555 series

DIAL-LITE®

LED logic state/fault indicators

These low cost LED logic state/fault indicators are extremely versatile devices and lend themselves to a wide range of applications. Typically they might be used as fault indicators for trouble shooting complex circuits.

555-200X

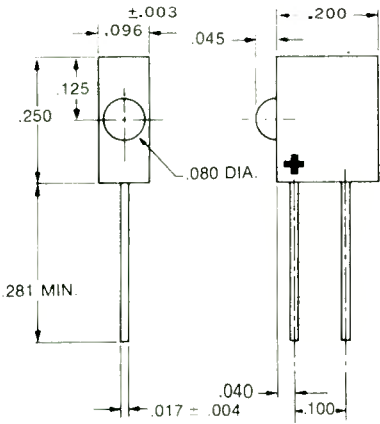

555-300X

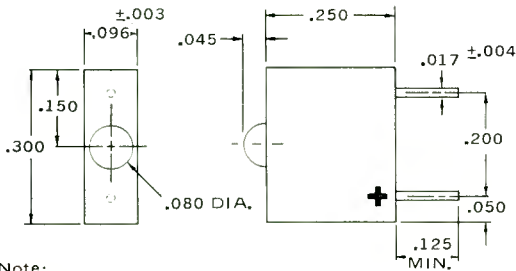

Note:
DECIMALS $\pm .015$

Ordering Information

Red Diffused		Volts	mA
555-2001	555-3001	1.7	*
555-2002	555-3002	3.6	20
555-2007	555-3007	5.0	3
555-2003	555-3003	5.0	6
555-2004	555-3004	5.0**	16
555-2005	555-3005	10.0	14
555-2006	555-3006	14.0	10

* Requires external resistor. Maximum DC forward current 50 mA. Typical operating current 20mA.

** For higher brightness, can be operated at 6V @ 20 mA.

Printed in U.S.A.

Copyright 1974 by Dialight, Brooklyn, N.Y. 11237

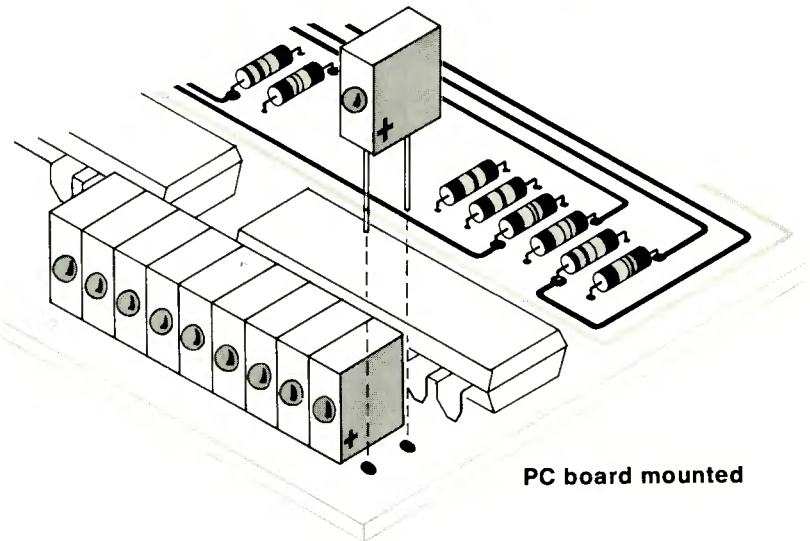

PC board mounted

Other possible applications

- Logic state indicator.
- Binary data display—permits stacking so that multiple functions can be displayed.
- Indicator light.

Features

- Gallium Arsenide Phosphide LED.
- Low cost.
- Can be driven directly from DTL and TTL logic.
- Very low power consumption.
- High reliability—life measured in tens of years.
- Polarity identified.
- Built-in series resistor.
- Compact design permits dense packaging. Units can be mounted 10 units to the inch.
- Black case enhances contrast ratio.
- Available in range of voltages and currents.

Dialight reserves the right to make changes at anytime in order to improve design and to supply the best product possible.

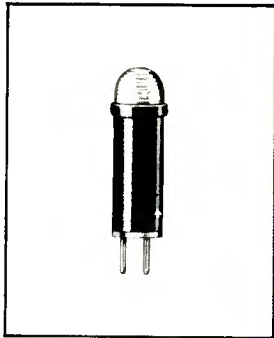

507 series

Datalamp Cartridges

with Red, Green or Yellow LED **DIODE-LITES®**

Features

- Low power requirements
- Integrated circuit compatibility
- Solid state reliability - life measured in years
- Immune to shock and vibration
- Operating temperatures - 55° C to +71° C
- Interchangeable with incandescent Datalamp cartridges
- Transient free switching
- Meet all applicable requirements of MIL - L-3661

A new addition has been made to Dialight's Datalite family of indicators...a Datalamp cartridge series accommodating a DIODE•LITE® (LED). The light source is a solid state lamp that provides the advantages of **low power** with extremely **long life**, **reliability** measured in years, and is compatible with integrated circuits (can be driven directly by RTL, DTL and TTL logic).

OPERATING VOLTAGES: The Datalamp cartridges with solid state DIODE•LITES® may be used as direct replacements for existing cartridges using an incandescent lamp operating from a DC power source. The former series is available in a range of voltages from 3.6 to 28V DC at a maximum current of 20 mA.* Tolerances on the DC Voltage should be within 5% of the specified voltage on the cartridge.



UNIQUE LENS DESIGN: Dialight uses an internal fresnel ring pattern in its lens design. This assures maximum distribution of the light output from the DIODE•LITE®. The lens area is completely flooded with light.

MAXIMUM CONTRAST: The Datalamp cartridge is supplied in a black anodized finish (standard) which produces a high contrast ratio. Such a ratio is desirable for optimum indication.

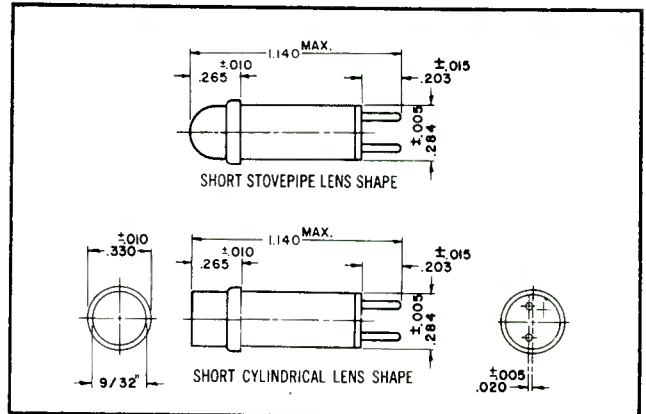

POLARITY: To facilitate proper installation of the cartridge, the polarity is marked (+) on the cartridge housing and the terminal base is keyed.

MATERIALS AND FINISHES

- **Housing:** Aluminum, Standard finish — black anodize.
- **Connections:** Stainless steel pins mounted in nylon insulated header. Offset to provide polarization.
- **Lens:** High strength plastic. Permanently attached to open end of the housing.

MOUNTING: This series Datalamp cartridge may be used with a Datalamp holder or cartridge connector with speed clip described on the following page.

Ordering Information

DATALAMP CARTRIDGES WITH SHORT CYLINDRICAL LENS SHAPE-WITH FRESNEL RINGS ☆							
WITH RED LED	TRANSPARENT LENS COLOR	3.6V DC	5V DC	6V DC	10V DC	14V DC	28V DC
		Red	507-4756-3331-500	507-4757-3331-500	507-4758-3331-500	507-4759-3331-500	507-4760-3331-500
	White	507-4756-3335-500	507-4757-3335-500	507-4758-3335-500	507-4759-3335-500	507-4760-3335-500	507-4761-3335-500
	Clear	507-4756-3337-500	507-4757-3337-500	507-4758-3337-500	507-4759-3337-500	507-4760-3337-500	507-4761-3337-500
WITH GREEN LED	Green	507-4856-3332-500	507-4857-3332-500	507-4858-3332-500	507-4859-3332-500	507-4860-3332-500	507-4861-3332-500
	White	507-4856-3335-500	507-4857-3335-500	507-4858-3335-500	507-4859-3335-500	507-4860-3335-500	507-4861-3335-500
	Clear	507-4856-3337-500	507-4857-3337-500	507-4858-3337-500	507-4859-3337-500	507-4860-3337-500	507-4861-3337-500
WITH YELLOW LED	Yellow (amber)	507-4956-3333-500	507-4957-3333-500	507-4958-3333-500	507-4959-3333-500	507-4960-3333-500	507-4961-3333-500
	White	507-4956-3335-500	507-4957-3335-500	507-4958-3335-500	507-4959-3335-500	507-4960-3335-500	507-4961-3335-500
	Clear	507-4956-3337-500	507-4957-3337-500	507-4958-3337-500	507-4959-3337-500	507-4960-3337-500	507-4961-3337-500

☆ To obtain cartridges with short stovepipe lens shape, change the first two digits in the 3rd code block from 33 to 37. Examples: 507-4856-3735-500; 507-4959-3737-500.

* Also available at 10 mA. Please consult factory

Printed in U.S.A.

Copyright 1974 by Dialight, Brooklyn, N.Y. 11237

Dialight reserves the right to make changes at anytime in order to improve design and to supply the best product possible.

DIALIGHT

203 HARRISON PLACE • BROOKLYN, N.Y. 11237 • 212 497-7600 • TWX: 710-584-5487

A NORTH AMERICAN PHILIPS COMPANY



for use with 507 Series

Datalamp Cartridges with Solid State **DIODE-LITES**®

see preceding page

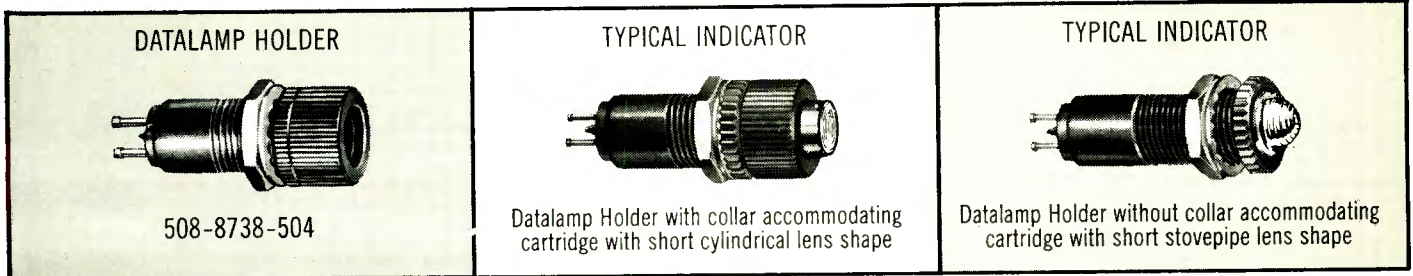

DATALAMP HOLDER: The Datalamp Holder is available with or without screw-on collar. The use of either is dependent on the desired front-of-panel appearance. The standard black anodize flange nut and collar produce the desired maximum contrast.

In addition, the terminals of the holder are marked "A" and "B". The "A" terminal would denote positive (+) polarity. This feature insures proper installation and wiring.

MATERIALS AND FINISHES

- **Mounting bushing, collar and flange nut:** Aluminum. Standard finish-black anodize. Optional-clear anodize.
- **Mounting Nut:** Brass, white nickel finish.
- **Internal-tooth Lockwasher:** Phosphor bronze, white nickel finish.
- **Terminals:** Phosphor bronze, gold plated.

Ordering Information

*DATALAMP HOLDER WITH TURRET TERMINALS		
TERMINAL TYPE	WITH COLLAR	WITHOUT COLLAR
	PART NUMBER	PART NUMBER
Turret	508-8738-504	250-8738-14-504

*To specify a Datalamp Holder with other than turret terminals, change so much of the part number that reads - 8738 - to - 7538 - (solder cup terminals); - 7438 - (solder blade terminals); to - 9038 - (Amp "53" taper pin receptacles). Example: 508-9038-504.

Datalamp Holders

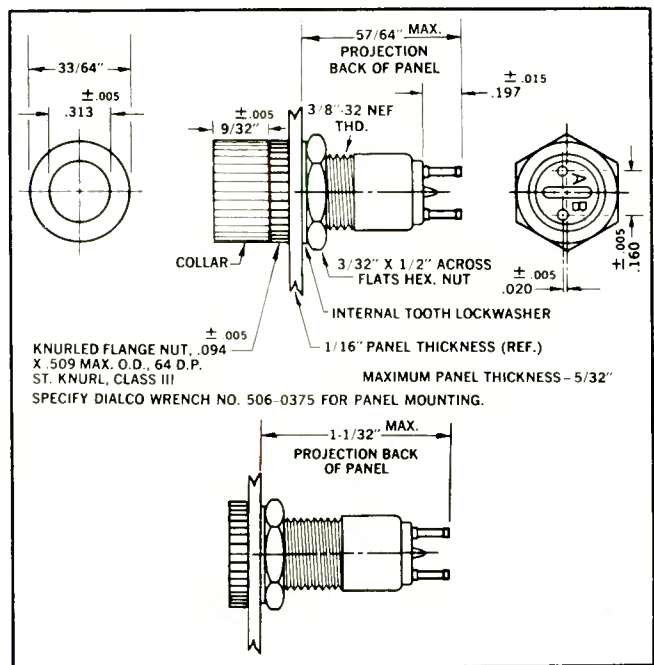

Cartridge Connector and Speed Clip

Cartridges may be directly mounted in panels using the accessories illustrated. The Datalamp cartridge is inserted through a clearance hole and is secured by sliding the speed clip over the housing from the rear. The connector is adapted for soldered wire leads and fits the Datalamp cartridge plug-in pins.

The terminals of the connector are marked "A" and "B". The "A" terminal would denote positive (+) polarity. This feature insures proper installation and wiring.



Connector
515-0012

Connector
515-0074



Speed Clip
515-0051

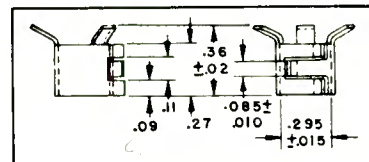
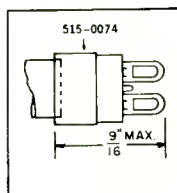
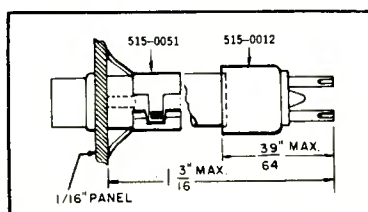

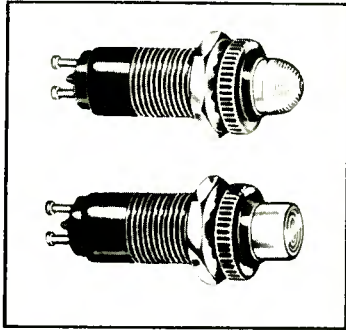

249 series

Ultra-Miniature Indicator Lights

with Red, Green or Yellow LED **DIODE-LITES**[®]

Features

- Low Power Requirements
- Integrated Circuit Compatibility
- Solid State Reliability
- Immune To Shock and Vibration
- Operating Temperatures - 55° C To +71° C
- Transient Free Switching

The 249 Series solid state indicator is a complete package-light source, housing and lens-ready for permanent panel mounting.

The light source is a solid state lamp that provides the advantages of **low power** with extremely **long life, reliability** measured in years, and is compatible with integrated circuits (can be driven directly by RTL, DTL and TTL logic).

OPERATING VOLTAGES: The 249 Series indicators with solid-state DIODE-LITES™ is available in a range of voltages from 3.6 to 28V DC at a maximum current of 20 mA. Tolerances on the DC voltage should be within 5% of the specified voltage.



UNIQUE LENS DESIGN: Dialight uses an internal fresnel ring pattern in its lens design. This assures maximum distribution of the light output from the DIODE-LITE™. The lens area is completely flooded with light.

MAXIMUM CONTRAST: The indicator is supplied in a black anodized finish (standard) which produces a high contrast ratio. Such a ratio is desirable for optimum indication.

POLARITY: To facilitate proper installation of the indicator, the terminal marked "+" denotes positive polarity.

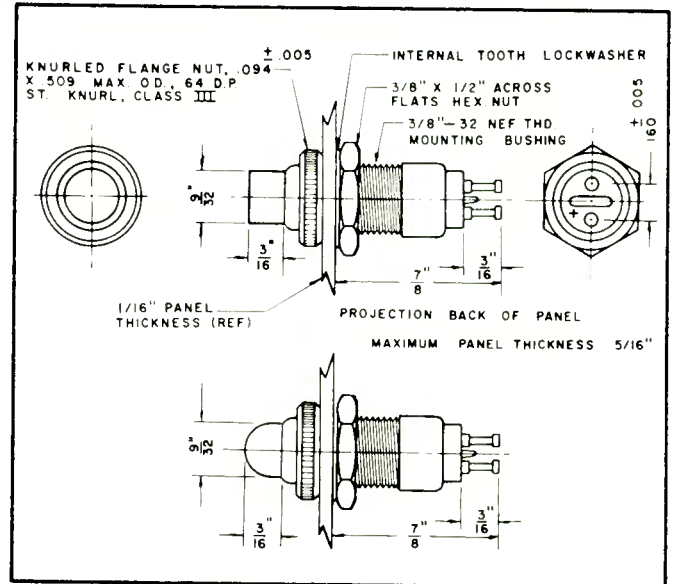

MATERIALS AND FINISHES

- **Mounting bushing and flange ring:** Standard-Aluminum, black anodized finish. Optional-clear anodize finish.
- **Mounting nut:** Brass, white nickel finish.
- **Internal-tooth Lockwasher:** Phosphor bronze, white nickel finish.
- **Terminals:** Low carbon steel, solder plated.
- **Lens:** High strength plastic. Internal fresnel ring pattern.

Ordering Information

INDICATOR LIGHTS WITH SHORT CYLINDRICAL LENS SHAPE - WITH FRESNEL RINGS ☆							
WITH	TRANSPARENT LENS COLOR	3.6V DC	5V DC	6V DC	10V DC	14V DC	28V DC
RED LED	Red	249-7867-3331-504	249-7868-3331-504	249-7869-3331-504	249-7870-3331-504	249-7871-3331-504	249-7872-3331-504
	White	249-7867-3335-504	249-7868-3335-504	249-7869-3335-504	249-7870-3335-504	249-7871-3335-504	249-7872-3335-504
	Clear	249-7867-3337-504	249-7868-3337-504	249-7869-3337-504	249-7870-3337-504	249-7871-3337-504	249-7872-3337-504
GREEN LED	Green	249-7967-3332-504	249-7968-3332-504	249-7969-3332-504	249-7970-3332-504	249-7971-3332-504	249-7972-3332-504
	White	249-7967-3335-504	249-7968-3335-504	249-7969-3335-504	249-7970-3335-504	249-7971-3335-504	249-7972-3335-504
	Clear	249-7967-3337-504	249-7968-3337-504	249-7969-3337-504	249-7970-3337-504	249-7971-3337-504	249-7972-3337-504
YELLOW LED	Yellow (amber)	249-8067-3333-504	249-8068-3333-504	249-8069-3333-504	249-8070-3333-504	249-8071-3333-504	249-8072-3333-504
	White	249-8067-3335-504	249-8068-3335-504	249-8069-3335-504	249-8070-3335-504	249-8071-3335-504	249-8072-3335-504
	Clear	249-8067-3337-504	249-8068-3337-504	249-8069-3337-504	249-8070-3337-504	249-8071-3337-504	249-8072-3337-504

☆ To obtain indicators with short stovepipe lens shape, change the first two digits in the 3rd code block from 33 to 37. Examples: 249-7968-3732-504; 249-8070-3737-504.

Printed in U.S.A.
Copyright 1974 by Dialight, Brooklyn, N.Y. 11237

Dialight reserves the right to make changes at anytime in order to improve design and to supply the best product possible.

DIALIGHT

A NORTH AMERICAN PHILIPS COMPANY

203 HARRISON PLACE • BROOKLYN, N.Y. 11237 • 212 497-7600 • TWX: 710-584-5487



558 and 559 Series

DIALIGHT[®] low cost
snap-in LED indicators

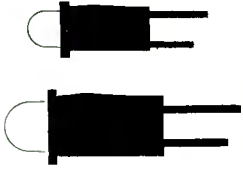

558 Series (WITH STRAIGHT TERMINALS)

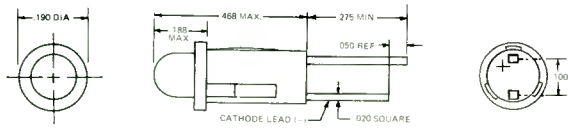

* Mounting Hole - .155" to .158" Diameter

559 Series (WITH STRAIGHT TERMINALS OR WIRE LEADS)

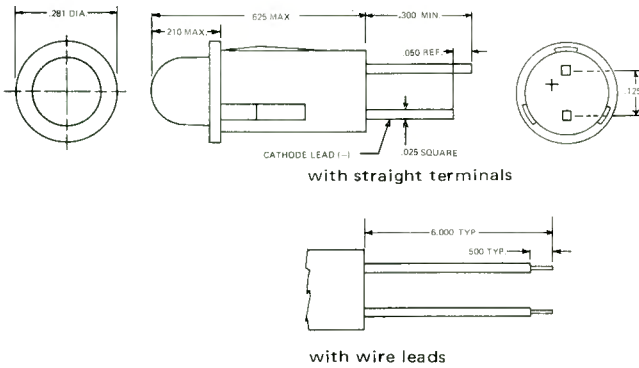

* Mounting Hole - .249" to .252" Diameter

558 Series: Mount in .156" hole
559 Series: Mount in .250" hole

Features

- Snap-in mounting requires no additional hardware
- Available with Red, Green or Yellow LEDs, with and without integral current limiting resistors
- Compact design allows high density packaging:
558 Series mounts on 0.2" centers
559 Series mounts on 0.3" centers
- Straight terminals suitable for wire-wrapping and/or soldering, or 6" wire leads
- Designed for quick positive insertion in panels from .031" through .062"
- Black housing enhances contrast ratio
- Polarity identified
- High Brightness LEDs
- Wide Angle visibility
- Low power requirements -15-20 mA
- Solid State reliability
- IC compatible
- Vibration and shock resistant

Applications

- Point of sale
- Computers
- Process Control
- Instrumentation
- Medical equipment
- Communications equipment
- Home entertainment equipment
- Vending machines

Ordering information—558 Series Indicators - mount in .156" hole*

LED COLOR	REQUIRES EXTERNAL RESISTOR	WITH INTEGRAL RESISTOR (5V, 15mA typical)
Red	558-0101-001	558-0102-001
Green	558-0201-001	558-0202-001
Yellow	558-0301-001	558-0302-001

Ordering information—559 Series Indicators - mount in .250" hole*

LED COLOR	REQUIRES EXTERNAL RESISTOR		WITH INTEGRAL RESISTOR (5V, 15mA typical)	
	straight terminals	wire leads	straight terminals	wire leads
Red	559-0101-001	559-0101-003	559-0102-001	559-0102-003
Green	559-0201-001	559-0201-003	559-0202-001	559-0202-003
Yellow	559-0301-001	559-0301-003	559-0302-001	559-0302-003

DIODE-LITE® low cost snap-in LED indicators

Operating Characteristics – 558 and 559 Series with Integral Resistor

Symbol	Characteristics	RED			GREEN			YELLOW			Units	TEST CONDITIONS		
		Min.	Typ.	Max.	Min.	Typ.	Max.	Min.	Typ.	Max.		RED	GR. YEL.	
I _v	Luminous Intensity:										mcd	V _F	5.0V	5.0V
	558 Series	.3	.8		.5	2.0		.5	2.0					
	559 Series	.8			.5	1.5		.5	1.5					
λ _{pk}	Wavelength		655			560			580		nm			
I _F	Forward Current		16	20		16	20		16	20	ma	V _F	5.0V	5.0V
BV _R	Reverse breakdown voltage	3			3			3			V	I _R	10 μA	10 μA

Operating Characteristics – 558 and 559 Series without Integral Resistor

Symbol	Characteristics	RED			GREEN			YELLOW			Units	TEST	CONDITIONS	
		Min.	Typ.	Max.	Min.	Typ.	Max.	Min.	Typ.	Max.			RED	GR. YEL.
I _v	Luminous Intensity:										mcd	I _F	20mA	10mA
	558 Series	.3	.8		.6	1.5		.6	1.5					
	559 Series	.8			.8			.8						
λ _{pk}	Wavelength		655			560			580		nm			
V _F	Forward Voltage		1.6	2.0	1.8	2.0	2.8	1.8	2.0	2.4	V	I _F	20mA	10mA
BV _R	Reverse break down voltage	3.0			3.0			3.0			V	I _R	10 μA	100 μA*

* 558-0101-001

Maximum Ratings – 558 and 559 Series with Integral Resistor

Characteristic	RED			GREEN			YELLOW			Units	TEST CONDITIONS		
	Min.	Typ.	Max.	Min.	Typ.	Max.	Min.	Typ.	Max.		RED	GR. YEL.	
Power Dissipation			100			112			112	mW	derate from 25 °C	1.62 mW/°C	1.49 mW/°C
DC Forward Voltage			7.5			7.5			7.5	V	derate to 5V @ 100 °C		
Reverse Voltage			7.0			7.0			7.0				
Operating and Storage Temperature	-55		+100	-20		+100	-20		+100	°C			
Lead Soldering Temperature			230			230			230	°C	Maximum 7 Seconds		

Maximum Ratings – 558 and 559 Series without Integral Resistor

Characteristic	RED			GREEN			YELLOW			Units	TEST CONDITIONS		
	Min.	Typ.	Max.	Min.	Typ.	Max.	Min.	Typ.	Max.		RED	GR. YEL.	
Power Dissipation			100			112			112	mW	derate from 25 °C	1.62 mW/°C	1.49 mW/°C
Forward DC Current			50			40			40	ma			
Peak Forward Current			1			1			1	A	1 μs pulse 300pps		
Peak Reverse Voltage			5			5			5	V			
Operating and Storage Temperature	-55		+100	-20		+100	-20		+100	°C			
Lead Soldering Temperature			260			260			260	°C	Maximum 5 seconds		

Typical Resistor Values – 558 and 559 Series without Resistor

DC Voltage	Red		Green - Yellow	
	Current @ 10 mA	Current @ 20 mA	Current @ 10 mA	Current @ 20 mA
	R _L	R _L	R _L	R _L
3.6	200 Ω	100 Ω	150 Ω	75 Ω
5	330 Ω	180 Ω	330 Ω	150 Ω
6	430 Ω	220 Ω	390 Ω	180 Ω
10	820 Ω	390 Ω	820 Ω	390 Ω
14	1200 Ω	620 Ω	1200 Ω	620 Ω
28	2700 Ω	1300 Ω	2700 Ω	1300 Ω

Typical Drive Circuits

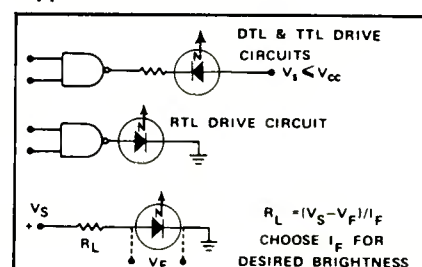

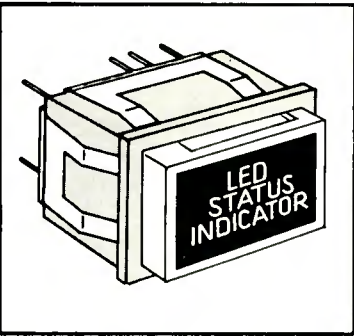

556/557 Series

DIODE-LITE®

solid state LED Status Indicator
snap-in panel mounting

Features

- LED Light Source
- Compact design - allows for high density legend presentation.
- Low power requirements - internal resistors limit current to 25 mA per lamp at 5 volts.
- Solid state reliability - life measured in years.
- Immune to shock and vibration.
- Legends and light cells are interchangeable - up to six independently illuminated legends.
- Snap-in mounting for panels from 1/16" to 3/16".
- Base assembly and legend cap available in a range of colors.

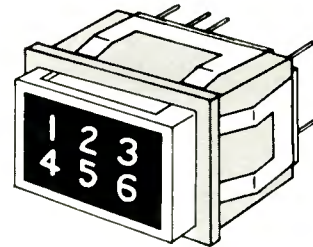

The 556 Series LED Status Indicator can be snap-in bezel mounted individually or side by side.

This unique product fills the requirement for a compact, low profile indicator with multi-legend capability. The legends in a negative presentation are illuminated by red light emitting diodes which provide maximum reliability with the lowest power requirement. An excellent contrast ratio between the illuminated and non-illuminated messages is provided.

The status indicator is offered with 4 or 6 LEDs and with adjustable light cell barriers to provide versatile cell layout and legend options. A maximum of 6 individually illuminated messages is possible.

The legend cap with fingertip grip, snaps into the base and is easily removed to permit changing of legends or cell configuration. Terminations for the indicator are .025" square pins which interface directly with dual inline IC sockets and can be wire wrapped or hard wired.

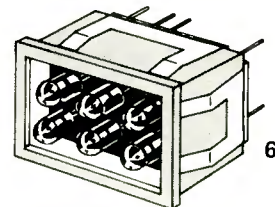

557 Series Status Indicator

Cap assembly (Nos. 1-5)

- 1 - lens cap frame
- 2 - red filter
- 3 - film legend
- 4 - diffuser
- 5 - light cell with adjustable barriers

556 Series Status Indicator

Base (No. 6)

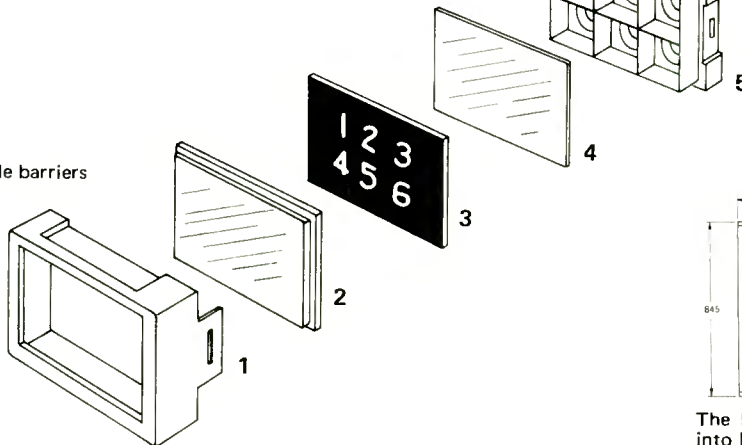

To change light cell configuration and/or film legends, remove lens cap frame from adjustable light cells, make the desired changes and simply snap lens cap frame back into place.

No tools are needed.

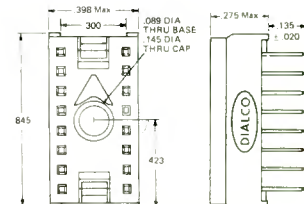

The 556 Series display will mount into Dialight's 501-0702-009 socket.

solid state LED Status Indicator

556 Series Status Indicator Base

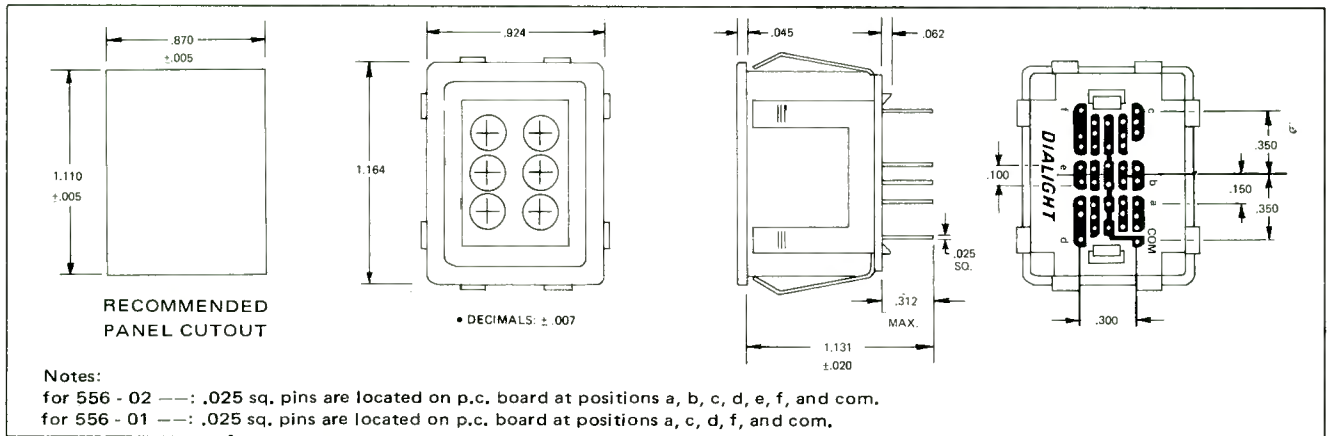

Light Cell Layouts with 4 LEDs

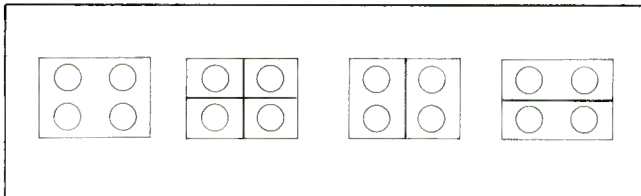

Light Cell Layouts with 6 LEDs

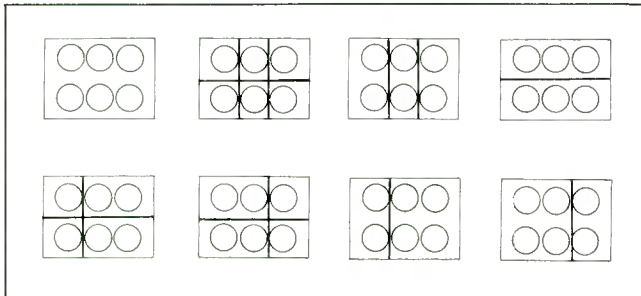

556 Series Status Indicator Base ordering information

Bezel Color	Status Indicator Base	
	with 4 LEDs	with 6 LEDs
Black	556-0101	556-0201
Gray	556-0102	556-0202
Dark Gray	556-0103	556-0203
White	556-0104	556-0204

Note: For green LEDs, consult factory.

557 Status Indicator Cap

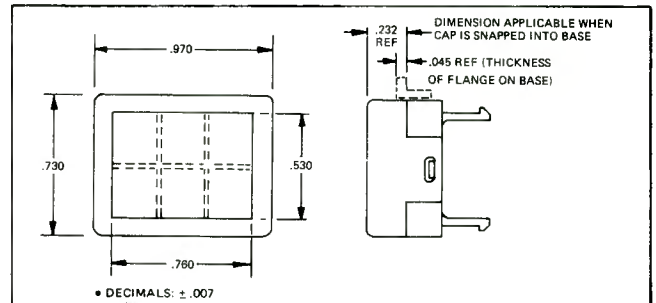

ordering information

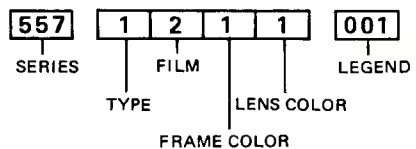

TYPE	FILM	FRAME COLOR	LENS COLOR
1 - 4 LAMP LED	0 - NONE	1 - BLACK	1 - RED
2 - 6 LAMP LED	1 -	2 - GRAY	2 -
	2 - NEGATIVE	3 - GRAY, DARK	3 -
		4 - WHITE	4 -
			5 -
			6 -
			7 - CLEAR

Legend Character Height	LEGEND STANDARDS			
	Horizontal		Vertical	
	Characters	Lines	Characters	Lines
.085"	12	4	8	6
.109"	9	3	6	4
.141"	6	2	4	3

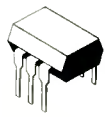

actual size

551-0002 and 551-0003 Opto-Isolator

compatible with standard DTL and TTL integrated circuits

551-0002 current transfer ratio 42% (typical)

551-0003 current transfer ratio 20% (typical)

Features

- Gallium Arsenide Light Source Optically Coupled to a Silicon N-P-N Phototransistor
- High Direct-Current Transfer Ratio
- Base Lead Provided for Conventional Transistor Biasing
- High-Voltage Electrical Isolation. . . 1.5-kV Rating
- Plastic Dual-In-Line Package
- High-Speed Switching: $t_r = 2 \mu s$, $t_f = 2 \mu s$ Typical

The 551 Series Opto-Isolators provide the designer with means to electrically isolate low voltage logic circuits from high voltage outputs. These optically coupled isolators connect two systems by the transmission of light energy (photons), thereby eliminating the need for a common electrical ground while providing effective isolation between the systems.

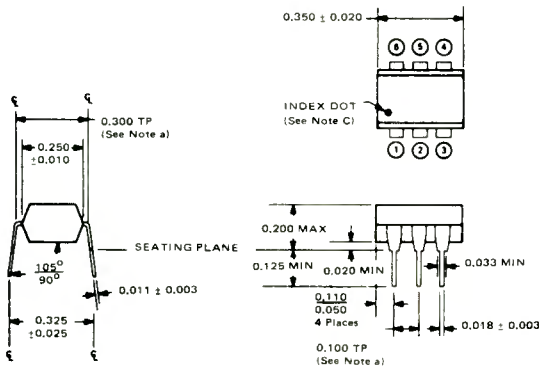

NOTES:

- Leads are within 0.005 radius of true position (TP) at the gauge plane with maximum material condition and unit installed.
- All dimensions are in inches unless otherwise noted.
- Pin 1 identified by index dot.
- Terminal connections:

1. Anode	}	Light-emitting diode
2. Cathode		
3. No internal connection		
4. Emitter	}	Phototransistor
5. Collector		
6. Base		

Mechanical Data

The package consists of a gallium arsenide light emitting diode and an n-p-n silicon phototransistor mounted on a 6-lead frame encapsulated within an electrically nonconductive plastic compound. The case will withstand soldering temperature with no deformation and device performance characteristics remain stable when operated in high-humidity conditions.

551-0002 and 551-0003

absolute maximum ratings at 25°C ambient-air temperature (unless otherwise noted)

	551-0002	551-0003
Input-to-Output Voltage	± 1.5 kV	± 1.5 kV
Collector-Base Voltage	70 V	30 V
Collector-Emitter Voltage (See Note 1)	30 V	20 V
Emitter-Collector Voltage	7 V	4 V
Emitter-Base Voltage	7V	4 V
Input-Diode Reverse Voltage	3 V	3 V
Input-Diode Continuous Forward Current at (or below) 25°C Ambient Temperature (Note 2)	60 mA	60 mA
Continuous Power Dissipation at (or below) 25°C Ambient-Air Temperature:		
Light-Emitting Diode (Note 3)	100 mW	100 mW
Phototransistor (Note 4)	150 mW	150 mW
Storage Temperature Range	-55°C to 150°C	-55°C to 150°C
Lead Temperature 1/16 inch from case for 10 seconds	240°C	240°C

- Notes: 1. This value applies when the base-emitter diode is open-circuited.
 2. Derate linearly to 100°C ambient-air temperature at the rate of 0.8 mA/°C.
 3. Derate linearly to 100°C ambient-air temperature at the rate of 1.33 mW/°C.
 4. Derate linearly to 100°C ambient-air temperature at the rate of 2 mW/°C.

electrical characteristics at 25° C ambient-air temperature

PARAMETER	UNIT	PART NO. 551-0002			PART NO. 551-0003				
		TEST CONDITIONS	MIN	TYP	MAX	TEST CONDITIONS	MIN	TYP	MAX
V _{(BR)CBO} Collector-Base Breakdown Voltage	V	I _C = 10 μA, I _E = 0, I _F = 0	70			I _C = 10 μA, I _E = 0, I _F = 0	30		
V _{(BR)CEO} Collector-Emitter Breakdown Voltage	V	I _C = 1 mA, I _B = 0, I _F = 0	30			I _C = 1 mA, I _B = 0, I _F = 0	20		
V _{(BR)EBO} Emitter-Base Breakdown Voltage	V	I _E = 10 μA, I _C = 0, I _F = 0	7			I _E = 10 μA, I _C = 0, I _F = 0	4		
I _{C(on)} On-State Collector Current	Phototransistor Operation	V _{CE} = 0.4 V, I _B = 0, I _F = 16 mA	2	7		V _{CE} = 5 V, I _B = 0, I _F = 10 mA	0.2	2	
	Photodiode Operation	V _{CB} = 0.4 V, I _E = 0, I _F = 16 mA	10	20		V _{CB} = 5 V, I _E = 0, I _F = 10 mA	2	10	
I _{C(off)} Off-State Collector Current	Phototransistor Operation	V _{CE} = 10 V, I _B = 0, I _F = 0	1	50		V _{CE} = 5 V, I _B = 0, I _F = 0	1	100	
	Photodiode Operation	V _{CB} = 10 V, I _E = 0, I _F = 0	0.1	20		V _{CB} = 5 V, I _E = 0, I _F = 0	0.1	50	
DC Current Transfer Ratio	%	V _{CE} = 0.4 V, I _B = 0, I _F = 16 mA	12.5	42		V _{CE} = 5 V, I _B = 0, I _F = 10 mA	2	20	
V _F Input Diode Static Forward Voltage	V	I _F = 16 mA	1.2	1.4		I _F = 10 mA		1.2	1.5
V _{CE(sat)} Collector-Emitter Saturation Voltage	V	I _C = 2 mA, I _B = 0, I _F = 16 mA	0.25	0.4		I _C = 2 mA, I _B = 0, I _F = 50 mA		0.25	0.5
R _{in-out} Input-to-Output Internal Resistance	Ω	V _{in-out} = ± 1.5 kV, See Note 5	10 ¹¹			V _{in-out} = ± 1.5 kV, See Note 5	10 ¹¹		
C _{in-out} Input-to-Output Capacitance	pF	V _{in-out} = 0, f = 1 MHz, See Note 5	1	1.3		V _{in-out} = 0, f = 1 MHz, See Note 5	1	2	

Note 5: These parameters are measured between both input diode leads shorted together and all the phototransistor leads shorted together.

switching characteristics at 25° C ambient-air temperature - Part Nos. 551-0002 & 551-0003

PARAMETER	TEST CONDITIONS	MIN	TYP	MAX	UNIT
t _r Rise Time	Phototransistor Operation V _{CC} = 10 V, I _{C(on)} = 2 mA, R _L = 100 Ω		2	15	μs
t _f Fall Time		See Test Circuit A		2	
t _r Rise Time	Photodiode Operation V _{CC} = 10 V, I _{C(on)} = 20 μA, R _L = 1 k Ω		1		μs
t _f Fall Time		See Test Circuit B		1	

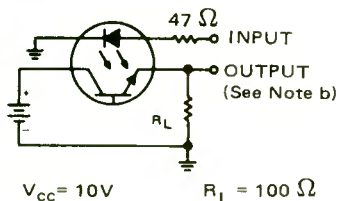

TEST CIRCUIT A
PHOTOTRANSISTOR OPERATION

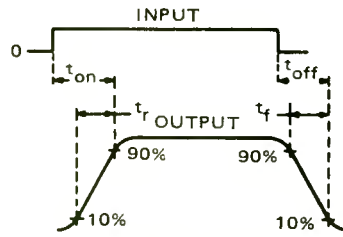

VOLTAGE WAVEFORMS

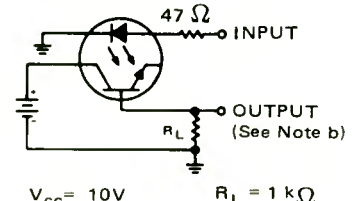

TEST CIRCUIT B
PHOTODIODE OPERATION

Adjust amplitude of input pulse for:
 I_{C(on)} = 2 mA (Test Circuit A) or I_{C(on)} = 20 μA (Test Circuit B)

- NOTES: a. The input waveform is supplied by a generator with the following characteristics: Z_{out} = 50 Ω, t_r < 15 ns, duty cycle ≈ 1%, t_w = 100 μs.
 b. The output waveform is monitored on an oscilloscope with the following characteristics: t_r < 12 ns, R_{in} > 1 MΩ, C_{in} < 20 pF.

typical characteristics

551-0002 ONLY

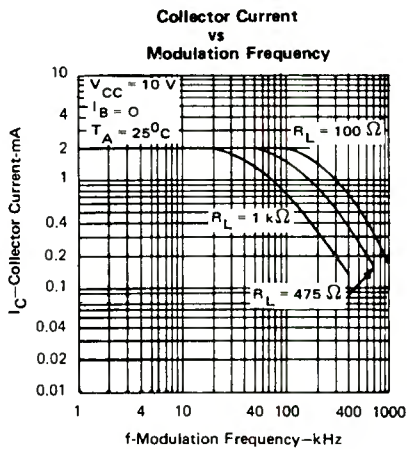
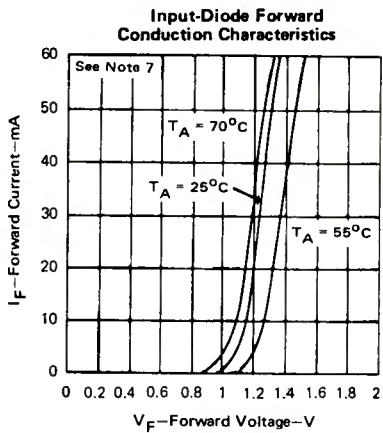
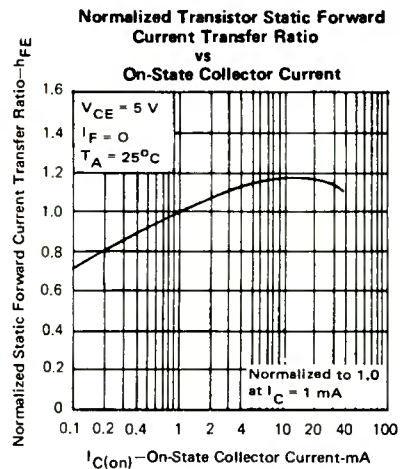
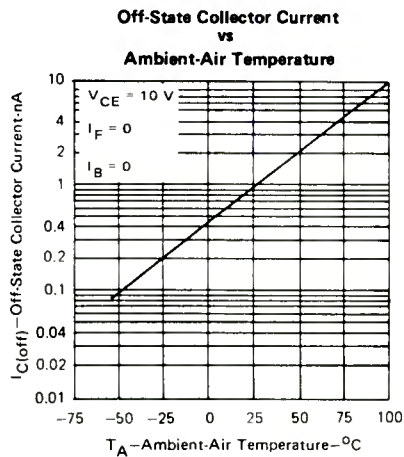
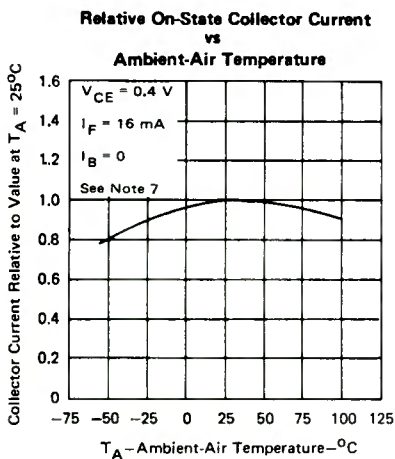
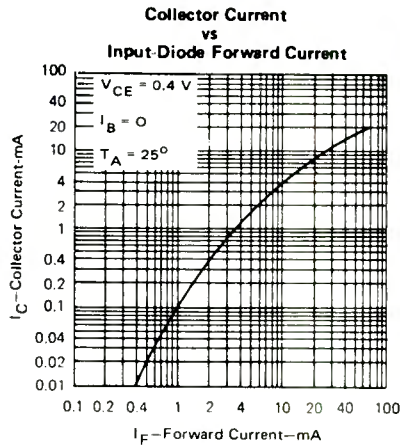
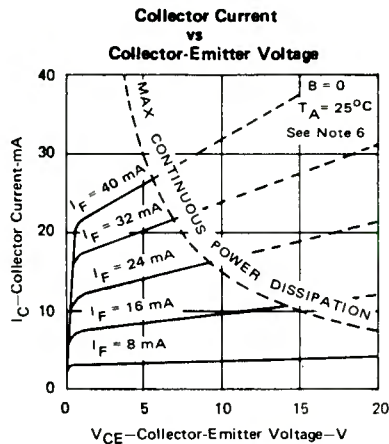

NOTES: 6. Pulse operation of Input diode is required for operation beyond limits shown by dotted line.
7. These parameters were measured using pulse techniques $t_w = 1$ ms, duty cycle $\leq 2\%$.



typical characteristics 551-0003 ONLY

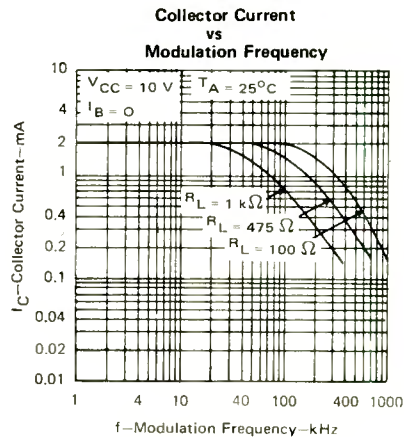
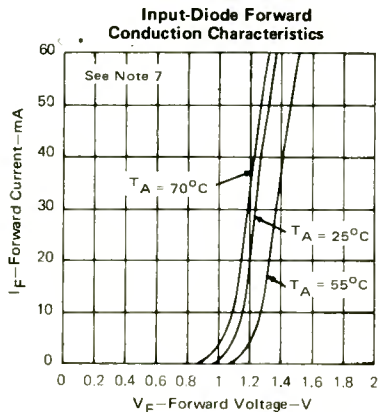
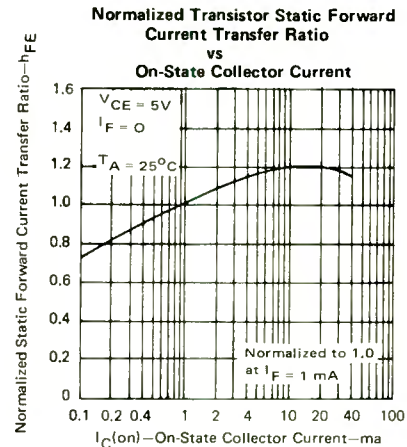
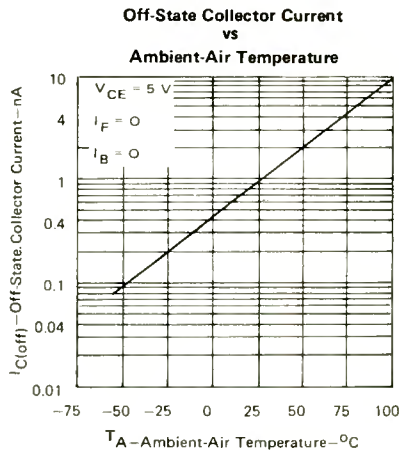
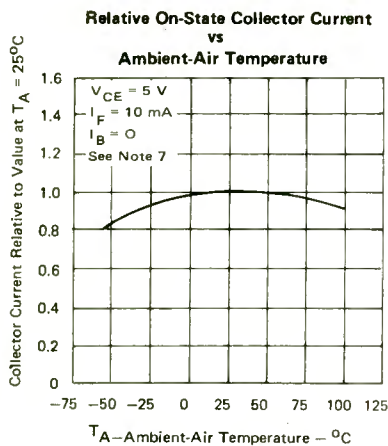
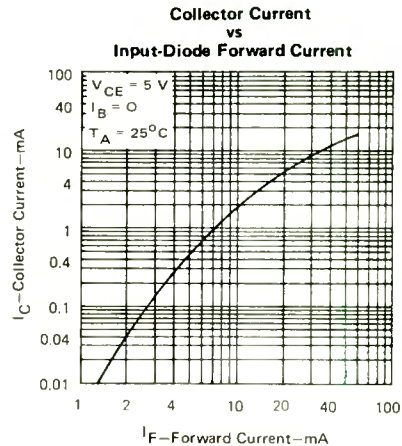
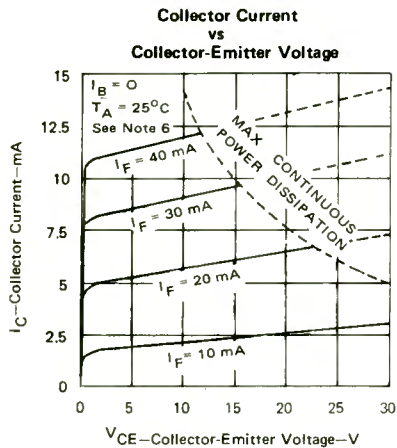

NOTES: 6. Pulse operation of input diode is required for operation beyond limits shown by dotted line.
7. These parameters were measured using pulse techniques $t_w = 1$ ms, duty cycle $\leq 2\%$.

additional products available from Dialight

(though not described in this catalog).

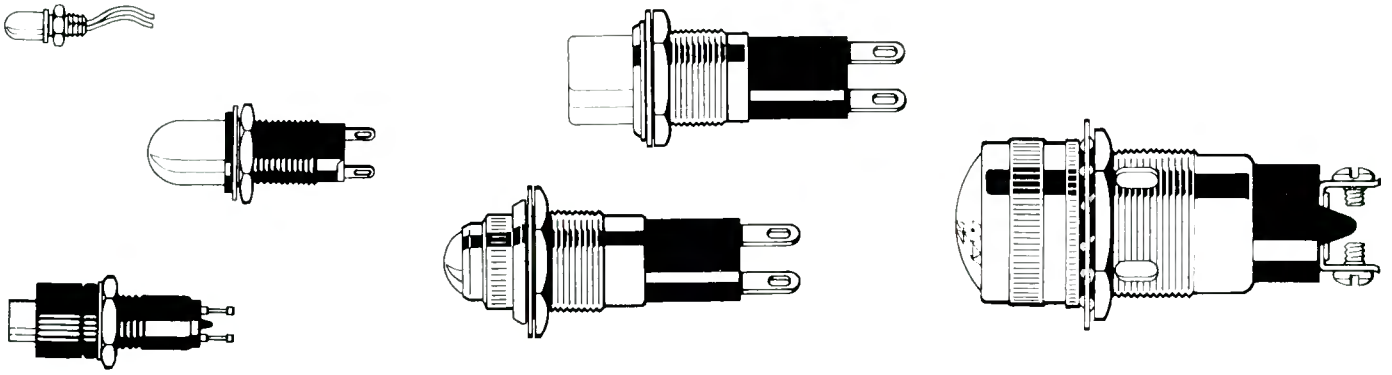

indicator lights are available in a wide range of sizes, colors and finishes.

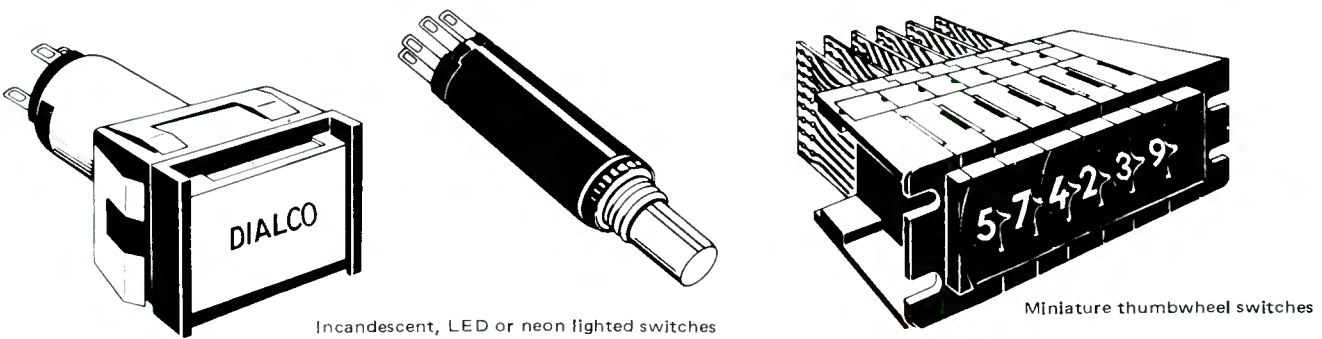

Incandescent, LED or neon lighted switches

Miniature thumbwheel switches

INDICATOR LIGHTS—available are incandescent, neon or LED lighted indicators in a wide range of sizes, colors and finishes. Oil-tight, water tight units, press-to-test, placard lights and MIL-SPEC indicators also available for special applications.

To obtain data on above items, ask for INDICATOR LIGHT PRODUCT SELECTOR GUIDE SG730.

READOUTS—LED . Gas Discharge . Incandescent—Single digit modules are available in .270", .300", .550", .625" and 1.000" heights. Displays and bezel mounted readout assemblies can also be obtained for quick, easy panel mounting.

To obtain data, ask for READOUT PRODUCT SELECTOR GUIDE - Catalog SG742.

SWITCHES—LED . Incandescent . Neon—Switches are available for most applications. Dialight can give you illuminated push button switches with unlimited cap and bezel options...solid state switches that eliminate all mechanical switching problems... LED lighted switches... even thumbwheel switches.

To obtain data, ask for SWITCH Catalogs L-210 and SW6120.

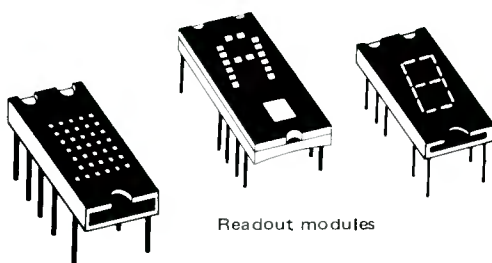

Readout modules



Gas Discharge Readouts

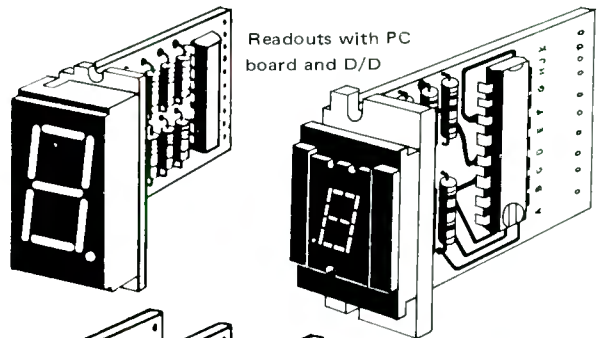

Readouts with PC board and D/D

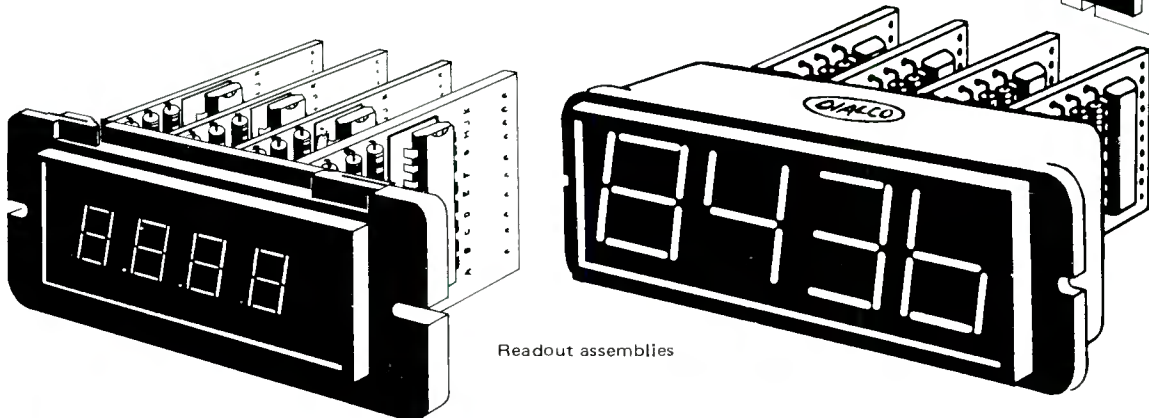

Readout assemblies



Available Now From These Stocking Distributors.

ARIZONA Moltronics of Arizona, Inc. Phoenix 602-272-7951	LOUISIANA Ralph's of Lafayette, Inc. Lafayette 318-234-4507	State Electronics Hanover 201-887-2550	Pioneer-Cleveland Elect. Cleveland 216-587-3600	Harrison Equip. Co., Inc. Houston 713-224-9131
CALIFORNIA Western Electromotive, Inc. Culver City 213-870-7621	Southern Radio Supply Co. New Orleans 504-524-2343	Newark Electronics Kenilworth 201-272-8460	RPC Electronics, Inc. Cleveland 216-461-4700	Lenert Co. Houston 713-225-1465
Westates Electronics Corp. Chatsworth 213-341-4411	MARYLAND Radio Elec. Service Co. Baltimore 800-823-0070	Resco Electronics Pennsauken 609-662-4000	Hughes-Peters, Inc. Columbus 614-294-5351	Newark Houston Elect. Corp. Houston 713-782-4800
Newark Electronics, Inc; Inglewood 213-678-0441	Cramer/EW Washington Gaithersburg 301-948-0110	Terminal Jersey Electronics Rahway 201-381-5700	Pioneer/Dayton Dayton 513-236-9900	UTAH Standard Suuply Co. Salt Lake City 801-355-2971
Sacramento Electronic Supply Sacramento 916-441-4821	Pioneer Washington Elect. Gaithersburg 301-948-0710	Federated Electronics, Inc. Springfield 201-376-8900	Stotts-Friedman Co. Dayton 513-224-1111	VIRGINIA Priest Electronics Norfolk 703-855-0141
Fisher/Brownell Santa Clara 408-244-6182	Capital Radio Wholesalers Rockville 301-881-2270	NEW YORK (Metropolitan area) Harrison Electronics East Farmingdale 516-293-7990	Lima Radio Parts Co. Lima 419-228-1220	Meridian Elect. Inc. Richmond 804-355-6521
Richey Electronics, Inc. Sun Valley 213-875-2862	MASSACHUSETTS DeMambro Electronics Boston 617-787-1200	Ancar Electronics Supply, Inc. Elmsford 914-592-7100	Radio & Elect. Parts (Repc) Solon 216-248-8906	WASHINGTON Almac/Stroum Electronics Seattle 206-763-2300
Bell Industries Sunnyvale 408-734-8570	Sager Electrical Supply Co. Boston 617-542-2281	Arrow Electronics Inc. Farmingdale 516-694-6800	OKLAHOMA Radio Inc. Tulsa 918-587-9123	WISCONSIN Electronics Expeditors, Inc. Milwaukee 414-228-8100
COLORADO Meter Master Inst. Corp. Denver 303-722-5766	Gerber Electronics Inc. Dedham 617-329-2400	Dalis Industrial Elect. L.I.C. 212-361-1100	OREGON Almac/Stroum Elect. Portland 503-292-3534	Parts Mart Corp. Milwaukee 414-276-4160
Newark-Denver Elect. Inc. Denver 303-757-3351	Cramer Electronics Inc. Newton 617-969-7700	Peerless Radio Corp. Lynbrook 516-593-2121	PENNSYLVANIA Seaway Elect. Supply Co. Erie 814-455-1304	
CONNECTICUT Surburban Supply Co. Waterbury 203-757-1251	T.F. Cushing, Inc. Springfield 413-788-7341	Harvey Electronics Woodbury 516-921-8700	Pyttronic Industries Inc. Montgomeryville 215-643-2850	
FLORIDA Hammond Electronics, Inc. Orlando 305-849-6060	Industrial Components Corp. Wilbraham 413-596-3854	NEW YORK STATE Stack Industrial Elect. Binghamton 607-723-6326	Almo Elect. Corp. Philadelphia 215-676-6000	CANADA
GEORGIA Specialty Dist. Co. Atlanta 404-873-2521	MICHIGAN Wedemeyer Electronics Ann Arbor 313-665-8611	Summit Distributors, Inc. Buffalo 716-884-3450	Philadelphia Elect. Inc. Philadelphia 215-568-7400	BRITISH COLUMBIA L.A. Varah Ltd. Vancouver 604-873-3211
ILLINOIS Newark Electronics Corp. Chicago 312-638-4411	RS Electronics Detroit 313-491-1000	Summit Elect. of Rochester Rochester 716-334-8110	Cameradio Electronics Pittsburgh 412-288-2600	MANITOBA Cam Gard Supply Winnipeg 204-786-8481
Electronic Distributors, Inc. Chicago 312-283-4800	Newark Electronics Oak Park 313-548-0250	Rome Electronics Rome 315-337-5400	Barbey Electronics Reading 215-376-7451	ONTARIO Saynor Electronics Ltd. Don Mills 416-445-2340
Allied Electronics Elgin 312-697-8200	Newark Electronics Corp. Wyoming 616-241-6681	NORTH CAROLINA Hammond Elect. of Carolina Greensboro 919-275-6391	RHODE ISLAND Wm. Dandreta & Co. Providence 401-861-2800	Cesco Electronics Downsview 416-661-0220
Klaus Radio & Elec. Co. Peoria 309-691-4840	MINNESOTA Gopher Electronics Corp. St. Paul 612-645-0241	Southeastern Radio Supply Raleigh 919-828-2311	SOUTH CAROLINA Hammond Elect. of Carolina Greenville 803-233-4121	Cesco Electronics Ottawa 613-729-5118
INDIANA Fort Wayne Elect. Supply Ft. Wayne 219-423-3422	MISSOURI LCOMP-Kansas City, Inc. No. Kansas City 816-221-2400	Cramer Electronics Winston-Salem 919-725-8711	TENNESSEE Radio Elect. Supply Co. Kingsport 615-247-8111	Wackid Radio TV Labs Ottawa 613-728-1821
Graham Electronic Supply Indianapolis 317-634-8486	LCOMP-St. Louis, Inc. St. Louis 314-647-5505	OHIO Akron Elect. Supply Co. Akron 216-762-8816	Electra Dist. Co. Nashville 615-329-3971	Zentronics, Ltd. Toronto 416-789-5111
Ra-Dis-Co. Indianapolis 317-637-5571	Walters Radio Supply Inc. Kansas City 816-531-7015	Sun Radio Co. Akron 216-434-2171	TEXAS Texas Instrument Supply Dallas 214-238-6971	Electro Sonic Supply Willowdale 416-494-1666
Radio Dist. Co. South Bend 219-287-2911	NEBRASKA Scott Electronic Supply Lincoln 402-464-8308	Newark Electronics Cincinnati 513-874-5115	Allied Electronics Inc. Forth Worth 817-336-4501	QUEBEC Cesco Electronics Ltd. Montreal 514-735-5511
KENTUCKY P.I. Burks Co. Louisville 502-589-3960	NEW JERSEY Milgray/Delaware Valley, Inc. Cherry Hill 609-424-1300	Hughes-Peters Inc. Cincinnati 513-351-2000	Newark Elect. Corp. Garland 214-271-2511	Payette Radio Ltd. Montreal 514-878-4771

DIALIGHT

203 HARRISON PLACE • BROOKLYN, N.Y. 11237 • 212 497-7600 • TWX: 710-584-5487

A NORTH AMERICAN PHILIPS COMPANY





TWIN LAMP

PLACARD LIGHTS

for the illuminated display of
MAXIMUM MESSAGE IN MINIMUM SPACE

High reliability achieved by the use of two
lamps and press-to-test feature (optional).

MEET REQUIREMENTS OF MIL-L-3661B

Dialco Twin Lamp Placard Lights are manufactured to meet applicable Military Standards, and conform to the environmental and operational requirements of MIL-E-5272, ABMA-MPD-11023 and 11064.

PRINCIPAL FEATURES

- Compact: easily mounted
- 4 mounting methods
- Press-to-Test for greater reliability
- May be used singly or in any grouping desired
- Two lamps assure that burnout of one lamp will not result in failure of the indication
- Easy lamp and legend replacement—from the front without the use of tools

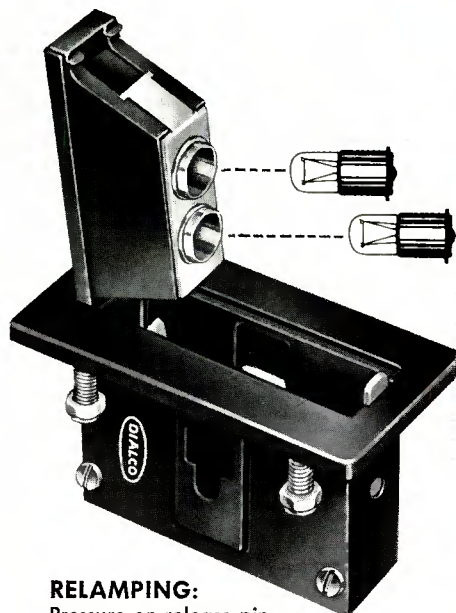

RELAMPING:

Pressure on release pin opens top plate 110° for relamping from the front... without removing the assembly and without the use of special tools.

GROUPING:
Any number of units may be stacked (10 maximum) to suit the application.

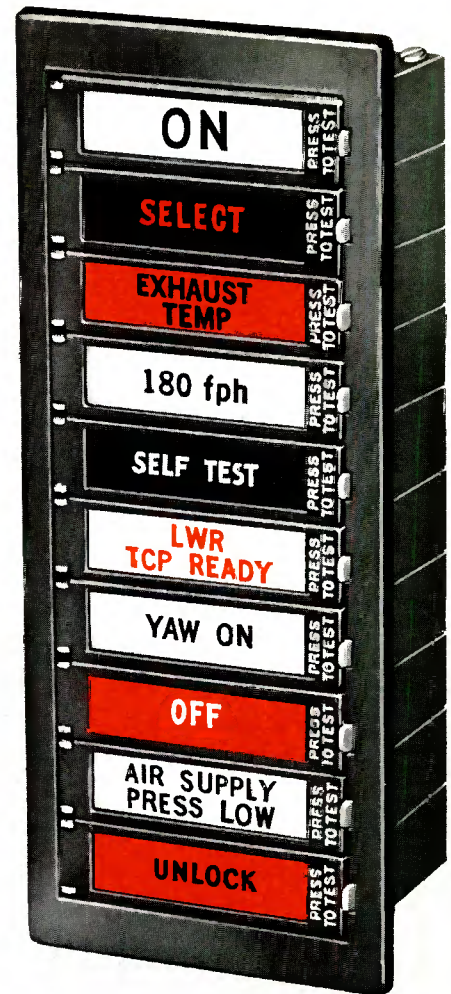

THE LIGHT SOURCE:

Two T-1¾ Incandescent Bulbs (with midjet flanged base) are used in each Placard Light assembly. The range of voltages is as follows:

MANUFACTURER'S RATINGS				
LAMP NO.	MILITARY NO.	VOLTS	AMPS	LIFE HOURS
7332	-----	5.0	.60	60,000
328	MS25237	6.0	.20	1,000
349	-----	6.3	.20	3,000
381	-----	6.3	.20	50,000
330	-----	14.0	.08	750
382	-----	14.0	.08	50,000
370	-----	18.0	.04	1,000
327	MS25237	28.0	.04	1,000
387	MS18209	28.0	.04	25,000

PRESS-TO-TEST: A light pressure on the right side of the legend plate frame closes an internal switch that makes a direct connection to the power supply and lights both lamps. (See schematic on P. 3.)

A BRIEF SUMMARY of the DIALCO line of Placard Lights is presented in the following pages. Additional data, drawings, etc. will be gladly furnished on request.

DIALIGHT
MANUFACTURERS OF VISUAL INDICATORS

CORPORATION

60 STEWART AVENUE • BROOKLYN, N.Y. 11237 • 212 497-7600 • TWX: 710-584-5437

A NORTH AMERICAN PHILIPS COMPANY



TWIN LAMP PLACARD LIGHTS

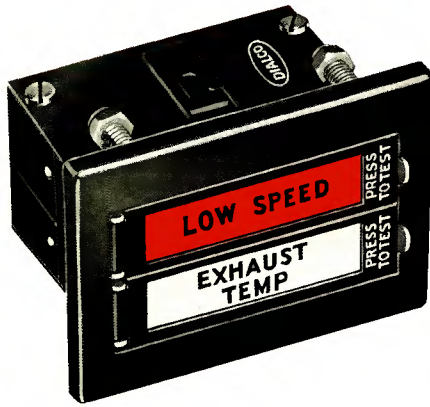

A typical stack of 2 PRESS-TO-TEST Placard Lights with escutcheon plate and horizontal legend.

CUSTOM-BUILT TO INDIVIDUAL REQUIREMENTS

Since the applications of Placard Lights vary with customers' requirements, there is no so-called "standard" unit. Basic types of DIALCO Placard Lights are assembled to order...either singly or in groups or stacks. A wide choice is offered in: style of legends and colors, size and color of type, method of mounting, etc. For unusual applications, the assistance of the DIALCO Engineering Department is readily available.



A single NON-PRESS-TO-TEST Placard Light with escutcheon plate and vertical legend.

Assemblies with ESCUTCHEON PLATES Available singly or in stacks of up to 10 Indicator Assemblies

3 Terminal-Press-to-Test

COLOR OF LEGEND PLATE*	SINGLE UNIT WITH SINGLE PLATE		SINGLE UNIT WITH DUAL PLATE	
	NEW CATALOG NO.	OLD CAT. NO.	NEW CATALOG NO.	OLD CAT. NO.
White	520-1292-0375-101	VM292-5		
Red	520-1292-0371-101	VM292-6	520-1292-0371-301	VM292-66
Green	520-1292-0372-101	VM292-7	520-1292-0372-301	VM292-67
Yellow (Amber)	520-1292-0373-101	VM292-8	520-1292-0373-301	VM292-68
Blue	520-1292-0374-101	VM292-11	520-1292-0374-301	VM292-611
Base Assembly (without legend plate)	520-1292-03-001		520-1292-03-001	

MIL-L-3861B: LHC81/11-20 is covered by 520-1292-03-001 through -010.

*Colors are translucent.

2 Terminal Non-Press-to-Test

COLOR OF LEGEND PLATE*	SINGLE UNIT WITH SINGLE PLATE		SINGLE UNIT WITH DUAL PLATE	
	NEW CATALOG NO.	OLD CAT. NO.	NEW CATALOG NO.	OLD CAT. NO.
White	520-1291-0375-101	VM291-5		
Red	520-1291-0371-101	VM291-6	520-1291-0371-301	VM291-66
Green	520-1291-0372-101	VM291-7	520-1291-0372-301	VM291-67
Yellow (Amber)	520-1291-0373-101	VM291-8	520-1291-0373-301	VM291-68
Blue	520-1291-0374-101	VM291-11	520-1291-0374-301	VM291-611
Base Assembly (without legend plate)	520-1291-03-001		520-1291-03-001	

MIL-L-3861B: LHC81/1-10 is covered by 520-1291-03-001 through -010.

*Colors are translucent.

STANDARD: Legends hot-stamped black in positive style. To designate optional features, see Placard Light Catalog Number System immediately below.

PLACARD LIGHT CATALOG NUMBER SYSTEM

Placard Complete with Legend Plate

Series: 520 | Model No.: 3:281 | Lens Detail: 1:37:5 | Legend Plate or Filter Color: 1:02

Mounting Method: 520 | Lettering Color: 3 | Plate Type: 1 | Stack: 02

MOUNTING METHOD	LETTERING COLOR	PLATE TYPE
0. No Plate or Bracket furnished	1. Black hot-stamp	1. Single legend plate.
1. Escutcheon Plates	2. Silver hot-stamp	3. Legend plate with underlying colored filter.
2. End Mounting Bracket	3. White hot-stamp	
3. Side Mounting Bracket	4. Negative-Engraved	5. Negative legend plate
4. "L" Angle Bracket		6. Underlying colored filter

LEGEND PLATE OR FILTER COLOR
1. Red
2. Green
3. Yellow (Amber)
4. Blue
5. White (Translucent)

TYPICAL EXAMPLES

For NEGATIVE style legend (see Figs. 2, 2A, 8 and 9), change:

- Lettering Color designation (first digit of code block three) to 4;
 - Plate Type designation (first digit of code block four) to 5.
- Example: 520-1291-4375-501

For a DUAL PLATE legend presentation of a white (translucent) legend plate and underlying colored filter (see Figs. 6 and 7), change:

- Underlying colored filter designation (last digit of code block three) to 1 (Red underlying filter);
 - Plate Type designation (first digit of code block four) to 3.
- Example: 520-3282-1371-301

For legends hot-stamped in silver or white (see Fig. 1B), change:

- Lettering color designation (first digit of code block three) to 2 if silver is desired; to 3 if white hot-stamping is desired.
- Examples: 520-1292-2371-101 (silver); 520-1291-3372-101 (white)

For stacks of 2 through 10, where all the legend and/or filter plates are in the same color, change:

- Stack designation (last two digits in code block four).
- Examples: 520-1291-0375-110 (stack of 10); 520-4281-1372-306 (stack of 6).

For stacking arrangements with more than one legend plate or filter color, hot-stamping color, Placard Light type or other special requirements—a control code suffix will be established to cover the specific details.

REQUIRED MOUNTING DIMENSIONS for ESCUTCHEON SERIES Assemblies

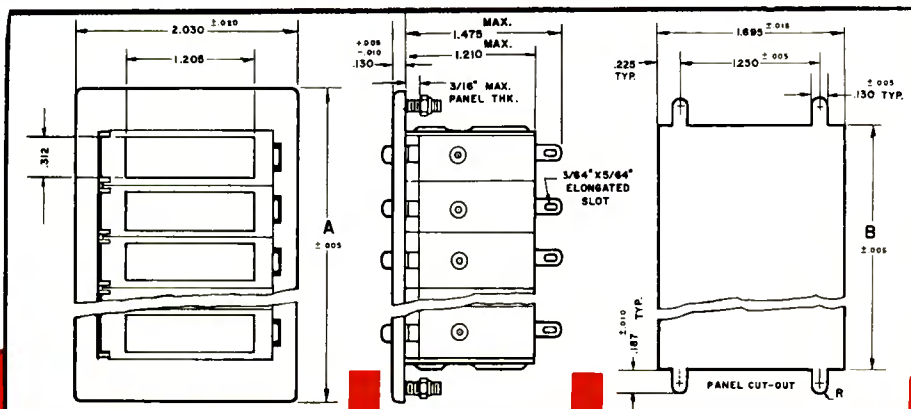

NUMBER OF INDICATORS	DIMENSIONS	
	"A"	"B"
1	1.063	.510
2	1.504	1.040
3	1.944	1.480
4	2.384	1.920
5	2.824	2.360
6	3.264	2.800
7	3.704	3.240
8	4.144	3.680
9	4.584	4.120
10	5.024	4.560

TWIN LAMP PLACARD LIGHTS



GENERAL DESCRIPTION

Placard Lights are indicators designed to provide the maximum display of message in the most compact area.

DIALCO Placard Lights are made in two general types:

- (1) The Three-Terminal "Press-to-Test" Placard Light.
- (2) Standard Two-Terminal Placard Light without press-to-test feature.

The Placard Light Assembly: Each unit contains a twin-lamp holder cell, attached to a hinged frame, which swings open 110° on depressing the release pin. Lamps are then accessible for easy replacement. The legend plate is mounted in the face of this cell which has a reflective liner for maximum illumination. The cell may be easily detached

from the frame for change of legend. The back portion of the Placard Light unit contains the spring contacts for the lamps and the press-to-test switching mechanism where applicable. Soldering terminals for external connections extend from the back of the unit.

Mounting Methods: The favored method is with an escutcheon plate which is stud mounted (see pages 1 and 2). For flush-to-panel mounting, the options are end-mounting, side-mounting, or with "L" angle brackets (see below). Flush-to-panel mounting is practicable on panels from 1/16" to 1/2" thick.

Grouping: All types (except the end-mounting type) can be stacked to suit the application.

OPTIONAL METHODS of MOUNTING

3 Terminal—Press-to-Test

COLOR OF LEGEND PLATE*	WITH END MTG. BRACKETS ■		WITH SIDE MTG. BRACKETS ■		WITH "L" ANGLE BRACKETS ■	
	NEW CATALOG NO.	OLD CAT. NO.	NEW CATALOG NO.	OLD CAT. NO.	NEW CATALOG NO.	OLD CAT. NO.
White	520-2282-0375-101	VM282-5	520-3282-0375-101	VM282-55	520-4282-0375-101	VM282-65
Red	520-2282-0371-101	VM282-6	520-3282-0371-101	VM282-56	520-4282-0371-101	VM282-66
Green	520-2282-0372-101	VM282-7	520-3282-0372-101	VM282-57	520-4282-0372-101	VM282-67
Yellow (Amber)	520-2282-0373-101	VM282-8	520-3282-0373-101	VM282-58	520-4282-0373-101	VM282-68
Blue	520-2282-0374-101	VM282-11	520-3282-0374-101	VM282-511	520-4282-0374-101	VM282-611
Base Assembly (without legend plate)	520-2282-03-001	—	520-3282-03-001	—	520-4282-03-001	—

*Colors are translucent.

■ A pair of brackets furnished with each unit.

2 Terminal Non-Press-to-Test

COLOR OF LEGEND PLATE*	WITH END MTG. BRACKETS ■		WITH SIDE MTG. BRACKETS ■		WITH "L" ANGLE BRACKETS ■	
	NEW CATALOG NO.	OLD CAT. NO.	NEW CATALOG NO.	OLD CAT. NO.	NEW CATALOG NO.	OLD CAT. NO.
White	520-2281-0375-101	VM281-5	520-3281-0375-101	VM281-55	520-4281-0375-101	VM281-65
Red	520-2281-0371-101	VM281-6	520-3281-0371-101	VM281-56	520-4281-0371-101	VM281-66
Green	520-2281-0372-101	VM281-7	520-3281-0372-101	VM281-57	520-4281-0372-101	VM281-67
Yellow (Amber)	520-2281-0373-101	VM281-8	520-3281-0373-101	VM281-58	520-4281-0373-101	VM281-68
Blue	520-2281-0374-101	VM281-11	520-3281-0374-101	VM281-511	520-4281-0374-101	VM281-611
Base Assembly (without legend plate)	520-2281-03-001	—	520-3281-03-001	—	520-4281-03-001	—

*Colors are translucent.

■ A pair of brackets furnished with each unit.

See **Placard Light Catalog Numbering System on Page 2**. The Catalog Numbers listed in all charts designate single units with single legend plate **without legends**. See page 2 for method of designating the various options such as legend presentations, groupings, etc.

PRESS-TO-TEST 3 Terminal Circuit

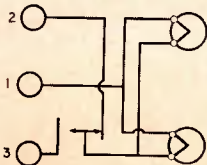

In schematic, terminal #1 connects to one side of power supply; #2 to the signalling switch, and #3 to the other side of the power supply.



A typical single Placard Light with end-mounting brackets.

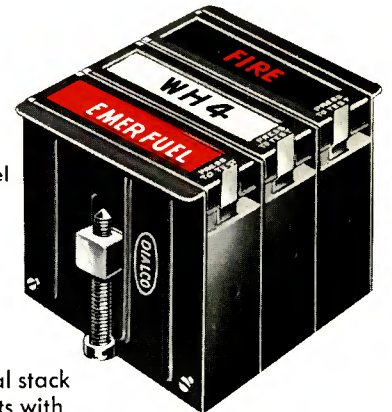

Specifications for Flush-to-Panel Mounting units will be furnished on request.

A typical stack of 3 units with side-mounting brackets.

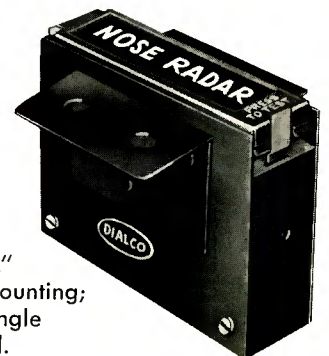

Typical "L" bracket mounting; may be single or stacked.

(All illustrations are approx. actual size)



TWIN LAMP PLACARD LIGHTS

LEGEND PLATES and MARKINGS

STYLES OF LEGENDS

Single Legend Plates are made of translucent plastic in 5 colors: White, Red, Green, Yellow (Amber) and Blue. The space available for legends is shown in the drawings. Standard: markings are hot-stamped in black in positive style. Optional: hot-stamped legends can be furnished in silver or white, and are recommended for use with red, green or blue legend plates. (Figs. 1, 1A, 1B).

Dual Legend Plates: The top plate is white and carries the legend hot-stamped in black; the underlying filter plate carries the color. Legend is positive style. (Figs. 6 and 7).

Negative Legends are furnished engraved through a black overlay into the colored legend plate. (Figs. 2, 2A, 8 and 9.)

We shall be pleased to recommend the best type of legend presentation for your specific application.

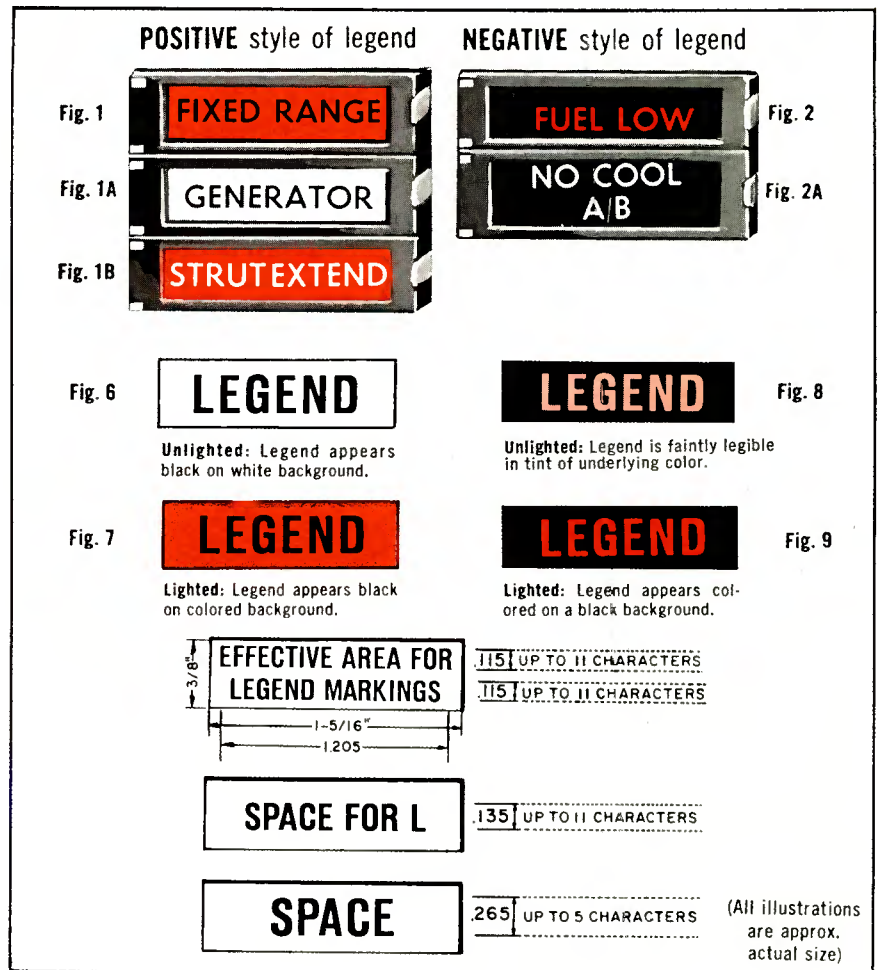

MATERIALS and FINISHES

- **Lamp Accommodation:** T-1 3/4 bulb, midget flanged base, incandescent.
- **Lamp Housing Bushing:** Brass, white nickel plated.
- **Lamp Housing:** Phenolic, black.
- **Legend Plate Holder:** Aluminum, black anodize finish.
- **Lamp Housing Contact Material:** Brass, white nickel plated.
- **Mounting Bracket Plate:** Aluminum, black anodize finish.
- **Escutcheon Plate:** Zinc alloy, yellow iridescent chromate. Face, black enamel. 4-40 NC-2 thread studs,

carbon steel, cadmium plated with yellow iridescent chromate.

- **Mounting Brackets (end, side, "L"):** Aluminum, black anodize finish. End and side brackets have brass, cadmium plated with yellow iridescent chromate insert. Holding screw is of carbon steel, cadmium plated with yellow iridescent chromate finish.
- **Release Pin:** Aluminum, clear anodize finish.
- **Pan Head Screws:** Steel, cadmium plated with yellow iridescent chromate.
- **Terminals:** Brass, hot-tinned; with elongated slots.

All specifications subject to change without notice.

Order **COMPLETE WITH LAMPS** so that you will be assured of receiving the Placard Lights and correct lamps at one time, ready for immediate use.

Printed in U.S.A.
Copyright 1973 by the Dialight Corp., Brooklyn, N.Y. 11237

Dialight Corporation reserves the right to make changes anytime in order to improve design and to supply the best product possible.

DIALIGHT
MANUFACTURERS OF VISUAL INDICATORS

CORPORATION

60 STEWART AVENUE • BROOKLYN, N.Y. 11237 • 212 497-7600 • TWX: 710-584-5487

A NORTH AMERICAN PHILIPS COMPANY



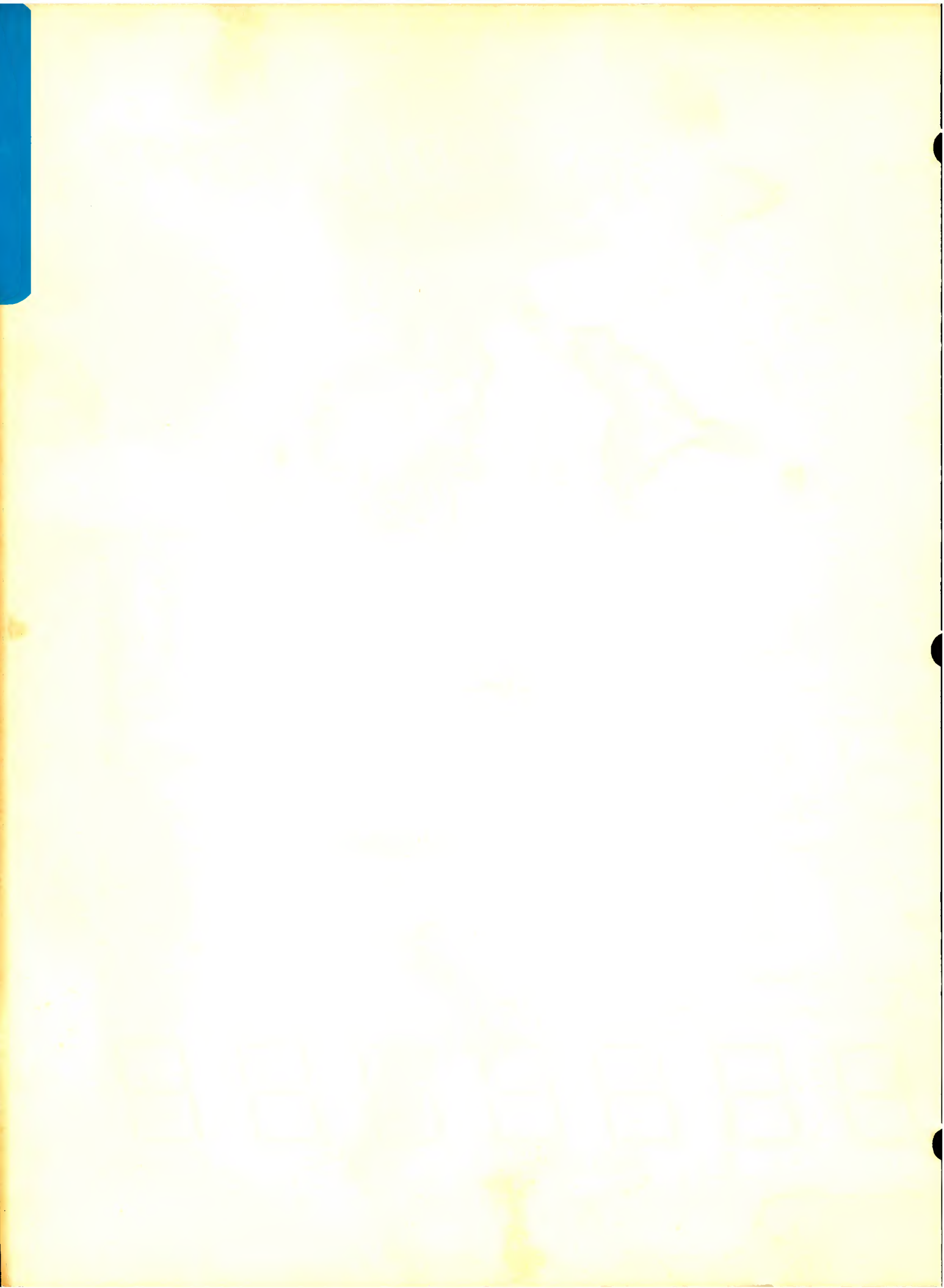

DIALIGHT

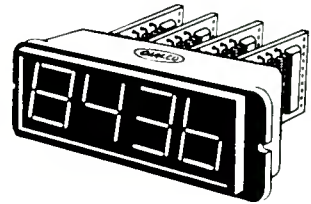

Readout Product Selector Guide

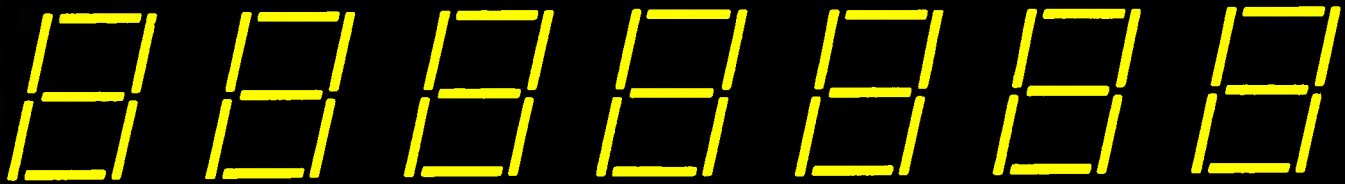

A NORTH AMERICAN PHILIPS COMPANY

CATALOG SG742

December 1974

DIALIGHT Readout Product Selector Guide

Table of contents

DESCRIPTION	PART OR SERIES NUMBER	PAGE NUMBER
General Information		5
LED READOUTS		
Character Height: .625"		
• LED display with & without D/D; also \pm 1 overflow	730 Series	7 - 8
• LED display assembly with IC D/D. Bezel mounting	739 Series	9 - 10
• LED Status Display - panel or bezel mounting	730 Series	11 - 14
• LED display with counter, latch and D/D	730-0027	15 - 16
• LED display with latch and D/D	730-0018	17
Character Height: .300"		
• LED Alphanumeric display	745-0005	18 - 20
• LED Alphanumeric display with 64 ASCII code generator	740-0018	21
Character Height: .270"		
• LED display	745-0006	22 - 24
• LED Hexadecimal display with logic	745-0007	25 - 28
• LED display with integral TTL MSI circuit chip, latch and D/D	745-0008	29 - 32
• LED display with integral TTL MSI circuit chip w/counter, latch and D/D	745-0009	33 - 36
• LED display	740-0005 & 740-0007	37 - 38
• LED display with D/D and latch	740-0011	39
• LED display assemblies (.270" & .300" characters)	749 Series	40 - 45
GAS DISCHARGE READOUTS		
Character Height: .550"		
• Readout display	755 Series	46 - 48
INCANDESCENT & NEON READOUTS		
Character Height: 1.0"		
• General Information		49 - 50
• Readout display	710 Series	51 - 52
• Status display	711 Series	53
• Accessories for 710,711 Series	712 & 713 Series	54
• Assembly & mounting	710 & 711 Series	55
• Display Face for PC board mounting	710 & 711 Series	56
DECODER/DRIVERS		
• BCD to Seven Segment - monolithic MSIIC	704 Series	57 - 58
CONVERTERS		
• Ten line to seven line	704 Series	59
STOCKING DISTRIBUTORS.....		back cover

DIALIGHT

A NORTH AMERICAN PHILIPS COMPANY

203 HARRISON PLACE • BROOKLYN, N.Y. 11237 • 212 497-7600 • TWX: 710-584-5487

Immediate Action Reply Form

Please use this form to obtain additional information.

RO

1 Yes, I'm interested in Diode-Lite (LED) visual displays.
Please add my name to your mailing list.

2 Within the next 12 months, I expect to select,
 specify, buy: _____
est, annual usage

- Diode-Lite (LED) readout modules _____
- Diode-Lite (LED) readout bezel assemblies _____
with _____ modules each _____
- Gas discharge readouts _____
- Incandescent and/or neon readouts _____
- Decoder/Drivers _____

3 I require more detailed information on this specific product:

please print product name or

catalog number(s)

4 My inquiry is for:

- a specific current application
- a possible future application
- reference use only

5 This application is the result of:

- new equipment or system design
- modification or redesign of existing equipment
- substitution of similar equipment

6 The above noted application will operate on:

Voltage: _____

Current: _____

7 For this application, about how many units will you require?

8 Please have Sales Representative phone me

Factory Sales Engineer phone me,
for needed assistance

9 Please send me current price list.

Comments: _____

Sketch Area

Name _____

Position _____ Dept. _____

Tel. _____ Ext. _____

Company _____

Street _____

City _____

State _____ Zip. _____

Please fold, staple or seal and mail.

FOLD HERE

FOLD HERE

First Class
Permit No. 27572
Brooklyn, N.Y.

BUSINESS REPLY MAIL No postage stamp necessary if mailed in the United States

Postage Will Be Paid By

DIALIGHT

203 HARRISON PLACE
BROOKLYN, N.Y. 11288



CUT ON DOTTED LINE



General Information

The following few paragraphs are devoted exclusively to assist you, the engineer or designer in selecting the proper Dialight readout for your application.

What is a readout? Basically, it is a device which will display data in a form easily read and requiring no further interpretation by the user.

Three basic types are offered by Dialight: Diode-Light (LED), Gas Discharge, Neon and Incandescent. Modules are offered as individual components or as integrated systems composed of both the character itself and the associated decoder-driver circuit. Further design advantages are achieved by offering a complete package, with either a bezel assembly, as in the LED series, or a panel bracket, as in the incandescent and neon series, for groupings of any amount of characters. Additional options offer decimal points, colons and polarity overflow modules.

LED READOUTS

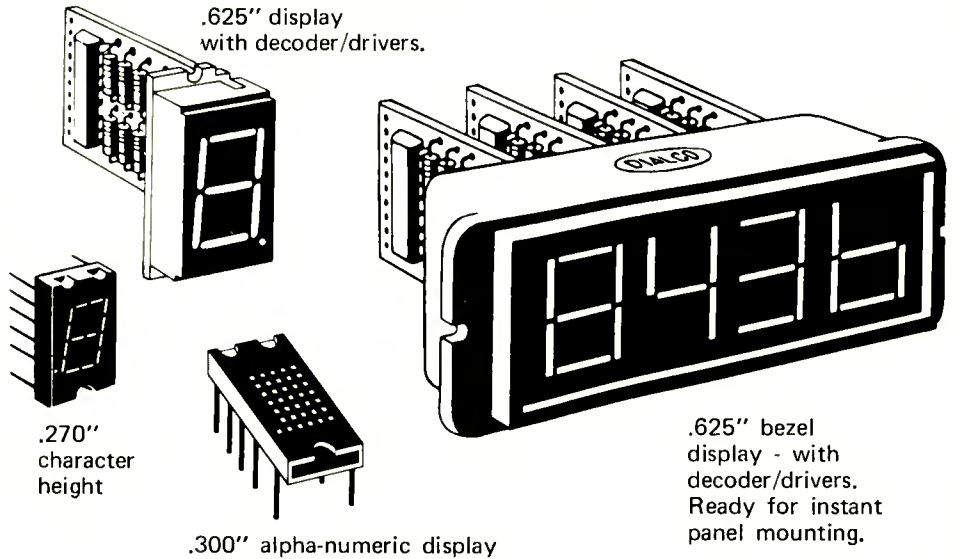
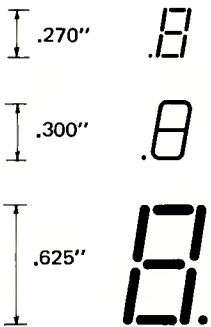

GAS DISCHARGE READOUTS



.550" character height. Available with 1½ or two digits.



Three Digit Display

INCANDESCENT & NEON READOUTS

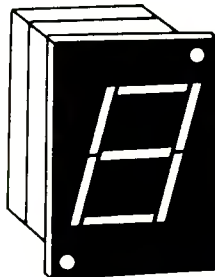
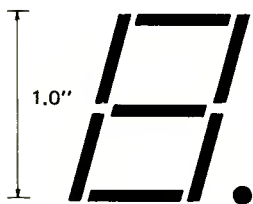

1.0" character height. Displays 0-9 and ten letters

1.0" character height. Low Cost Display Method. Uses front portion of display only.

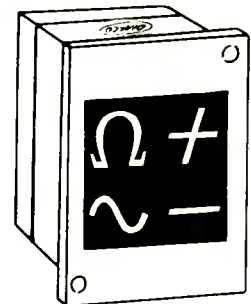
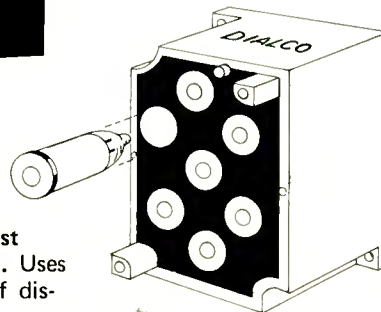

Status Display. Capable of displaying up to six captions.

Diode-Lite Readouts come in a variety of sizes, ranging from .270" to .625" in character height. Also available in this series is a full alpha-numeric display, in 5 x 7 dot matrix format and featuring a .300" high character. The device is offered as a basic module, or complete with character generator. The LED devices require low power, are IC compatible and are easily driven. Depending upon digit size, viewing distance in normal ambient will range from 10 to 25 feet, with brightness a current variable. As these are solid state devices, life is measured in years and the displays are particularly recommended in rugged applications since they are virtually immune to shock and vibration.

Because of the narrow emission spectrum, the special Dialight filters provide excellent character enhancement, permitting use in higher illumination environments (excluding direct sunlight). Should a device be accidentally damaged, the end piece of the bezel assembly in which they are supplied is easily removed permitting ready replacement of any module. Additional options offered in this series are latch and counters.

The **Gas Discharge display** is available in 1½, 2 and 3 digit models, featuring a .550" character, in an eye pleasing orange neon glow. The digits are highly readable under all conditions, clearly legible in direct sunlight, yet not overpowering in normal room ambient. Models may be stacked end to end for any size display, with uniform spacing retained.

A keep alive cathode is featured, providing an internal ion source that reduces reionization time, reduces anode supply voltage and improves operation in dark environments and at low temperatures. Power requirements are the lowest of the three readout types, with typical current drain only 330 µa per segment, or 2.3 ma for a figure 8.

The **Incandescent Readout**, available in a variety of colors, features a bright bold one-inch high digit, easily viewable at 35 feet and at angles as extreme as 140°. The light source is a standard T 1-¾ midget flanged base lamp, offered in voltage ranges of 5, 6, 14-16 and 24-28 volts, with minimum average life of 20,000 hours. Special non-glare windows are standard accessories. The removal of two screws detaches the rear portion of the module for lamp replacement. Standard terminals are solder blade, with printed circuit type offered as an option.

A based T 1-¾ **Neon**, the A1H, is also offered for use with the full 1" character module. Recommended operating voltage is 160VDC, with an external series resistor required for each lamp. Brightness of this lamp is maintained at basically initial value for tens of thousands of hours, with a slow and noticeable decline in light output a signal for replacement. When using neons, red or amber windows are suggested for optimum display.

Excluding the gas discharge models, the readouts are available with compatible status displays. These are back lighted devices, featuring from one to six legends, all individually controllable. Unlimited flexibility is offered since the displays are photographic transparencies. Typical formats are illustrated on the appropriate catalog pages.

SUMMARY

Diode-Lite LED Readouts should be considered where power is a limiting factor, or where IC compatibility is required and where ultra reliability and packaging density is a prime requirement.

Gas Discharge Readouts should be considered where low power and high reliability are required, where visibility under all lighting conditions is a requisite and where 170VDC is available.

Incandescent Readouts should be considered where large characters are required, where viewing distance is considerable, where more than one color is required and where drive requirements and voltage levels are flexible.

Neon Readouts, when used in place of incandescent, add to reliability, but limit color selection to red and amber.

Ambient light

Light existing in a room or other location which is characteristic of the environment.

Anode

Positive electrode

Binary Coded Decimal (BCD)

Pertaining to a number representation of system in which each decimal digit is represented by a unique arrangement of binary digits. The system is limited to the representation of the cardinal numbers 0 through 9.

Breakdown Voltage (firing voltage)

Initial firing voltage required to make the device glow.

Buffer

An isolating circuit used to avoid reaction of a driver circuit upon the corresponding driving circuit.

Cathode

Negative electrode. Source of free electrons.

Decimal Input

An input which allows the selection of one of ten possible states.

Flip-flop

A device containing active elements capable of assuming either one of two stable states at any given time.

Forward Voltage (VF)

The voltage across a semiconductor diode associated with the flow of forward current. The p-region is at a positive potential with respect to the n-region.

Gas Discharge Tube

Device where glow discharge occurs between metalized front glass plate (anode) and electrodes on insulating back plate (cathodes).

Hexadecimal Display

A solid state display capable of exhibiting numbers 0 through 9 and alpha characters A through F. Note: the 745-0007 is a hexadecimal display with an integral TTL circuit which will accept, store and display 4-bit binary data.

Ionization

The method of isolating an electron from an atom, creating a positive charge and a free electron.

Ionization Time

Time required for normal glow after application of a voltage in excess of breakdown. Time required to obtain full operating current and light output.

Light Emitting Diode (LED), Visible

An optoelectronic device containing a semi-conductor junction which emits visible light when forward-biased.

Load

A device which receives and dissipates power.

Luminance (L) (Brightness)

The luminous intensity of a surface in a given direction per unit of projected area of the surface as viewed from that direction. Typical units: fL, cd/ft², cd/cm². 1fL=.3183 cd/ft² or 3.426X10⁻⁴ cd/cm²

Luminous Intensity (Iv)

Luminous flux per unit solid angle in a given direction.

Micro Circuit

A term used to describe the miniaturization of solid state discrete components on to a continuous substrate.

Photon

A quantum (the smallest possible unit) of radiant energy; a photon carries a quantity of energy equal to Planck's constant times the frequency.

Rise Time (tr)

The time duration during which the leading edge of a pulse is increasing from 10% to 90% of its maximum amplitude.

Spectral Output (of a Light-Emitting Diode)

A description of a radiant-energy or light emission characteristic versus wavelength. This information is usually given by stating the wavelength at peak emission and the bandwidth between half-power points or by means of a curve.

Visible Emission, Visible Light

Radiation which is characterized by wavelengths of about 0.38µm to 0.78µm.

Wavelength at Peak Emission (λp)

The wavelength at which the power output from a light-emitting diode is maximum.

Typical units: Å, nm.

8421 Code

The decimal conversion code giving the significance (weight) of each digit in the binary word. Example: 1010=8x1+4x0=2x1+1x0=12



730 Series

DIODE-LITE[®]

solid state LED readout character height .625"

Standard Brightness — 16 mA per segment
High Brightness — 27 mA per segment

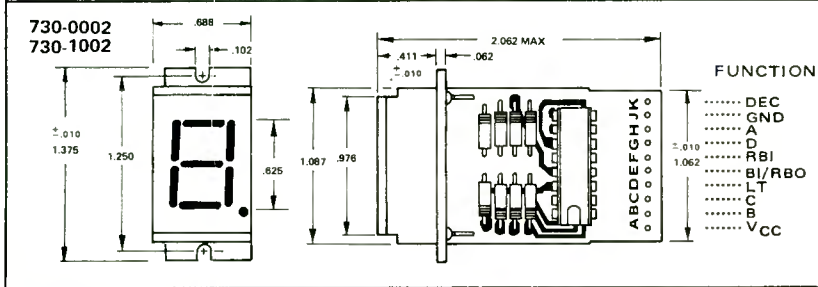
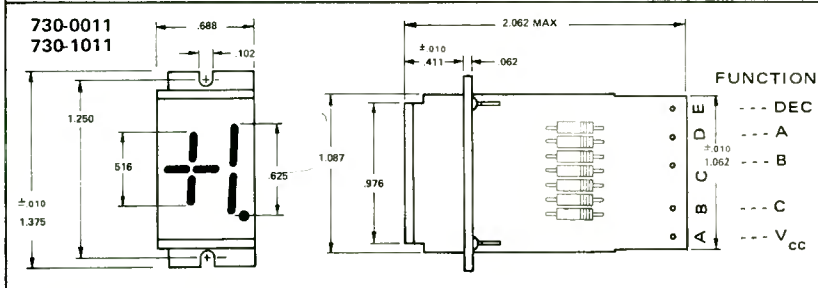
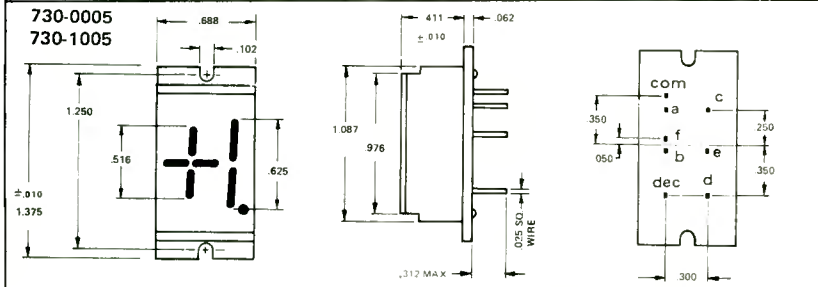
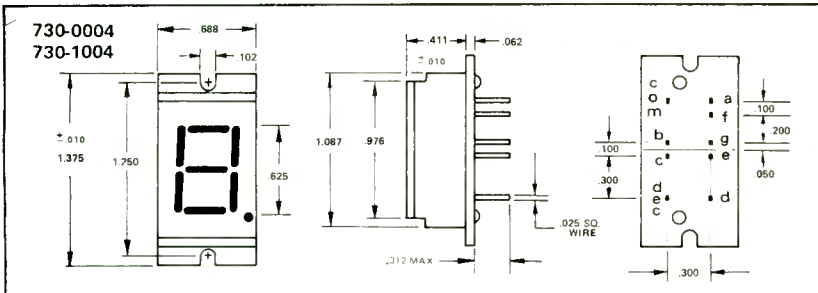
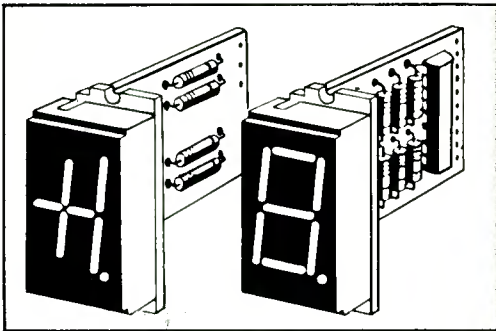

socket 501-0702-009
for use with 730-0004, 730-1004,
730-0005, 730-1005 modules

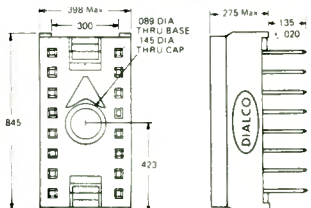

Edge Card
Connector
501-0700-005



The printed circuit boards mate with Dialight's 501-0700-005 edge card connector. Holes are provided in each board for hard wiring as an alternate means of connection.

Features

- .625" Diode-Lite Solid State Readout
- Plus-minus module
- Standard or high brightness LED
- Compact — Attractively designed
- Solid state reliability — life measured in years
- Immune to shock and vibration
- Lowest cost per character to comparable size
- Single plane display
- Operate with standard IC power supply levels
- Decimal point included

General Information

The Dialight 730 Series Readout Display uses standard or high brightness light emitting diodes for maximum light output. Using a unique lens design, the light output of the LEDs is arranged in a seven segment format. This generates a bright, highly legible red character.

730-0002 & 730-1002

The decoder/driver requires four lines or bits of information in a 8421 BCD code for each character of the display. Moreover, its terminals are brought out on the printed circuit board where the user has the option of wiring to it or using an edge card connector (see 501-0700-005 on the reverse side). Also provided is automatic blanking of the leading and/or trailing zero resulting for more easily read displays. It contains a lamp-test input that overrides the BCD inputs and can check for possible display malfunction.

730-0004 & 730-1004

These units require a resistor for each LED. The suggested resistor value for a 5 volt operation is 180 ohm 1/4 watt (standard brightness) or 120 ohm 1/4 watt (high brightness).

Ordering Information

Description	standard brightness	high brightness
Readout module	730-0004	730-1004
Plus-minus module	730-0005	730-1005
Readout with decoder/driver	730-0002	730-1002
Plus-minus module with resistors	730-0011	730-1011

* A snap-on non-glare red filter is provided with each readout module. Its use is recommended.

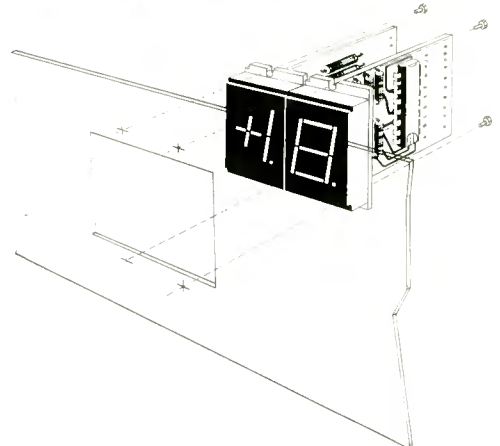

730 Series



DIAL-LITE[®] solid state LED readout character height .625" operating characteristics

(Ambient temperature 25° C)

schematics

Standard Brightness		High Brightness	
Part numbers	Supply Voltage (typical per character)	Part numbers	Supply Voltage (typical per character)
730-0002	5 volts @ 192 mA	730-1002	5 volts @ 281 mA
730-0004	5 volts @ 128 mA	730-1004	5 volts @ 216 mA
730-0005	5 volts @ 112 mA	730-1005	5 volts @ 189 mA
730-0011	5 volts @ 112 mA	730-1011	5 volts @ 189 mA

730-0002 730-1002

Supply Voltage, VCC	5 ± 0.5V
Supply Current	Standard Brightness: 177 mA all segments illuminated 192 mA all segments and decimal point illuminated
	High Brightness: 254 mA all segments illuminated 281 mA all segments and decimal point illuminated
Logic "1" } BCD Inputs	2.0 to 5.5V
Logic "0" } Inputs	0.0 to 0.8V, sink 1.6 mA
Logic "1" } DEC	Open
Logic "0" }	Standard Brightness: 0.0 to 0.8V, sink 16 mA
	High Brightness: 0.0 to 0.8V, sink 27 mA
Temperature Range	Standard Brightness: 0° to 70° C.
	High Brightness: 0° to 65° C.

Decoder/Driver 704-1549

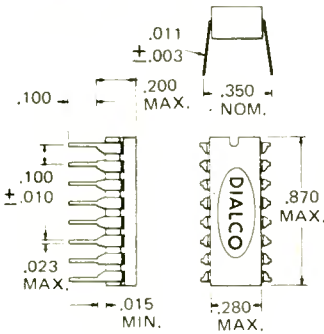

NOTE:

Leads are for insertion in hole rows on .300" centers. They are purposely shipped with .350" spacing in order to provide sufficient tension necessary to secure the package in the board during soldering.

730-0002

730-1002

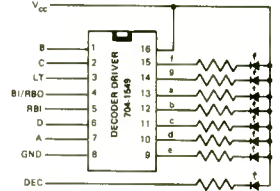

DECIMAL OR FUNCTION	INPUTS				BI/RBO	RESULTANT DISPLAY
	LT	RBI	DCB	A		
0	1	1	0	0	0	0
1	1	X	0	0	1	1
2	1	X	0	0	1	2
3	1	X	0	0	1	3
4	1	X	0	1	0	4
5	1	X	0	1	0	5
6	1	X	0	1	1	6
7	1	X	0	1	1	7
8	1	X	1	0	0	8
9	1	X	1	0	0	9
BI	X	X	X	X	X	0
RBI	1	0	0	0	0	0
LT	0	X	X	X	X	8

'1' = HIGH LEVEL,
'0' = LOW LEVEL
'X' = ANY LEVEL

• BI/RBO IS WIRE-AND LOGIC SERVING AS AN INPUT AND/OR OUTPUT

730-0004

Average current per segment 16 mA. For operation from 5 volts, a 180 ohm 1/4 watt resistor is suggested, absolute max. current 50 mA at 25° C.

V_E 1.7 - 2.0 volts at 20 mA

730-1004

Average current per segment 27 mA. For operation from 5 volts, a 120 ohm 1/4 watt resistor is suggested, Absolute max. current 50 mA, at 25° C.

V_F 1.8 - 2.3 volts at 50 mA.

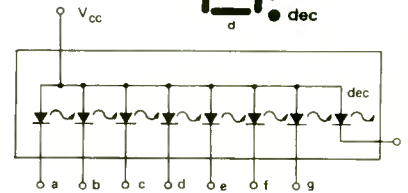
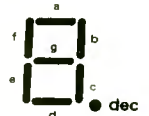

739 Series LED Readout Assembly

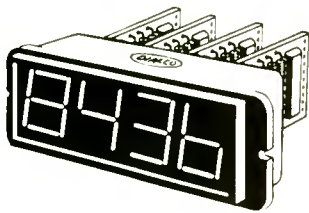

730 Readout modules are available for individual mounting or for bezel mounting. For individual mounting, the 730 series module, as described within this catalog sheet should be ordered. When ordering a 739 series assembly, a modified 730 series module is used. The chart below lists the appropriate part numbers.

For complete information on 739 Series LED Readout Assemblies, refer to data sheet in this catalog.

standard brightness		high brightness	
Non-Bezel Mtg.	Bezel Mtg. - For use in 739 Assembly	Non-Bezel Mtg.	Bezel Mtg. - For use in 739 Assembly
730-0004	730-0009	730-1004	730-1009
730-0005	730-0010	730-1005	730-1010
730-0002	730-0007	730-1002	730-1007
730-0011	730-0012	730-1011	730-1012

730-0005

Segment and Decimal point current: 16 mA
For operation from 5 volts, a 180 ohm 1/4 watt resistor for each segment and decimal point is suggested.

730-1005

Segment and Decimal point current: 27 mA.
For operation from 5 volts, a 120 ohm 1/4 watt resistor for each segment and decimal point is suggested.

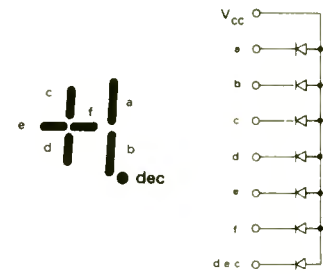

730-0011

Logic "1": 4.0 to 5.5 V or open
Logic "0": 0.0 to 0.4 V
Segment current: 16 mA/segment
Decimal point current: 16 mA
730-1011
Logic "1": 4.0 to 5.5 V or open
Logic "0": 0.0 to 0.4 V
Segment current: 27 mA/segment
Decimal point current: 27 mA

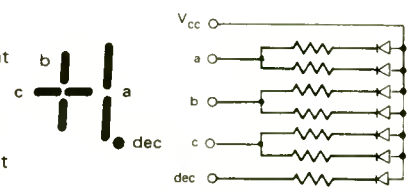

Printed in U.S.A.
Copyright 1974 by Dialight, Brooklyn, N.Y. 11237

Dialight reserves the right to make changes at anytime in order to improve design and to supply the best product possible.

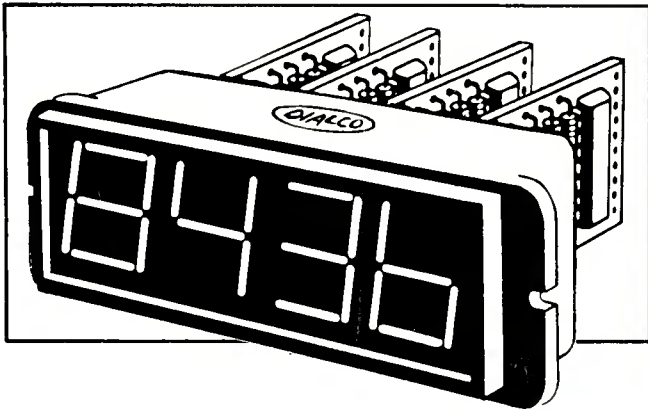

739 series

DIODE-LITE[®]

solid state LED

Readout Assembly

character height .625"

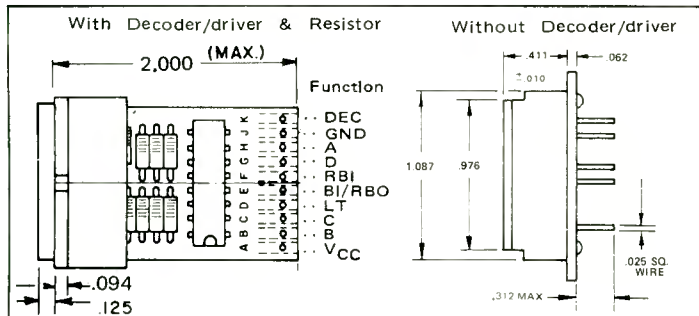

DECIMAL OR FUNCTION	INPUTS				* BI/RBO	RESULTANT DISPLAY
	LT	RBI	DCBA			
0	1	1	0000	1	0	
1	1	X	0001	1	1	
2	1	X	0010	1	2	
3	1	X	0011	1	3	
4	1	X	0100	1	4	
5	1	X	0101	1	5	
6	1	X	0110	1	6	
7	1	X	0111	1	7	
8	1	X	1000	1	8	
9	1	X	1001	1	9	
BI	X	X	XXXX	0		
RBI	1	0	0000	0		
LT	0	X	XXXX	1	8	

'1' = HIGH LEVEL, '0' = LOW LEVEL, 'X' = ANY LEVEL
 * BI/RBO IS WIRE-AND LOGIC SERVING AS AN INPUT AND/OR OUTPUT

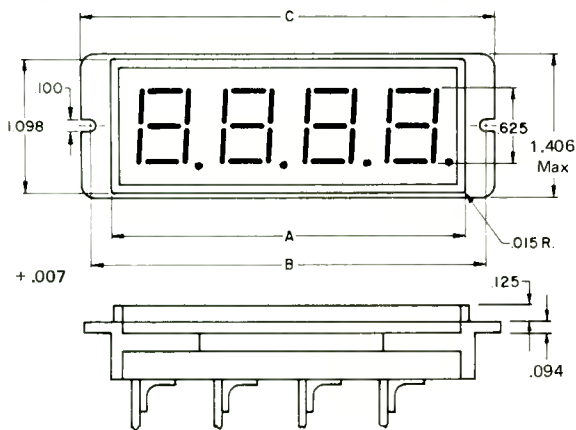

SUGGESTED PANEL CUTOUT

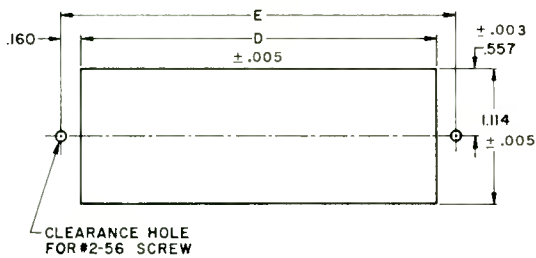

Complete assembly ready for instant panel mounting — Saves time, saves money

Features

- .625 inch Diode-Lite Solid State Readout, complete with Decimal Point
- Standard or High Brightness LED
- Available with or without IC Decoder/Driver
- Compact - Attractively designed - Convenient package with bezel simplifies panel mounting
- Solid state reliability - life measured in years
- Immune to shock and vibration
- Available in groups from 1 or more characters
- Lowest cost per character for comparable size
- Single plane character
- Operate with standard IC power supply levels
- For special applications, available with Colon and Spacer
- Latch and Counter options also available. Contact factory for details

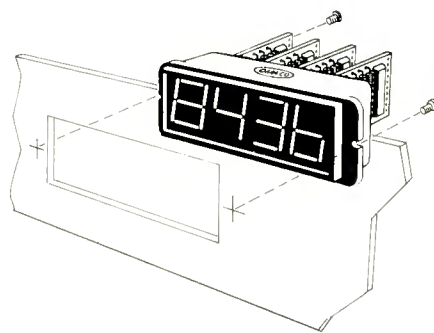

Part Number*	Char.	Dimension				
		A	B	C	D	E
739-010X-001	1	.882	1.218	1.374	.899	1.218
739-020X-001	2	1.570	1.906	2.062	1.587	1.906
739-030X-001	3	2.258	2.594	2.750	2.275	2.594
739-040X-001	4	2.946	3.282	3.438	2.963	3.282
739-050X-001	5	3.634	3.970	4.126	3.651	3.970
739-060X-001	6	4.322	4.658	4.814	4.339	4.658
739-070X-001	7	5.010	5.346	5.502	5.027	5.346
739-080X-001	8	5.698	6.034	6.190	5.715	6.034
739-090X-001	9	6.386	6.722	6.878	6.403	6.722
739-100X-001	10	7.074	7.410	7.566	7.091	7.410

*See 739 Series numbering system on reverse side

739 series

DIODE-LITE®



solid state LED Readout Assembly character height .625"

general information

The 739 Series of displays contain groups of Diode-Lite Readouts, with or without Decoder/Drivers and a stylish bezel assembly which provides for ease of installation in a panel

The Readout display is made up of high brightness or standard brightness diodes arranged in a seven segment format. This generates a bright, highly legible red character. The contrast ratio between the illuminated and

non-illuminated segments is further enhanced by the use of a red non-glare window.

The decoder/driver requires for each character in the display, four lines or bits of information in a 8421 BCD code. In addition, it also has terminals brought out on the PC board for automatic blanking of the leading and/or trailing edge zeros, resulting in a more easily read display. It also contains a lamp test input which over-rides the BCD inputs and can check for a possible display malfunction.

ordering information

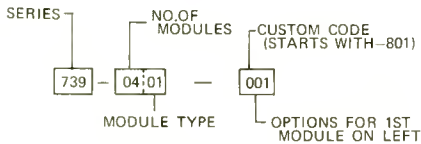

MODULE TYPE	LAST 3 DIGIT OF PART NO. (SUFFIX)
01 = 730 - 0007 (16 MA)	-001 = STD ASS'Y WITH ALL DIGITS -002 = STD ASS'Y WITH H ₁ -L ₁ W/O PC BOARD 730-0010 (16 MA) OR 730-1010 (27 MA)
02 = 730 - 1007 (27 MA)	
03 = 730 - 0009 (16 MA)	-003 = STD ASS'Y WITH H ₁ -L ₁ W/ PC BOARD 730-0012 (16 MA) OR 730-1012 (27 MA)
04 = 730 - 1009 (27 MA)	
05 = 730 - 0020 (16 MA)	-8XX = CUSTOM CODE (NON-STD ASS'Y)
06 = 730 - 1020 (27 MA)	
07 = 730 - 0029 (16 MA)	

operating characteristics

(Ambient temperature 25°C)

Supply Voltage, V _{CC}	5 ± 0.5V
Supply Current	Standard Brightness: 177 mA all segments illuminated 192 mA all segments and decimal point illuminated
	High Brightness: 254 mA all segments illuminated 281 mA all segments and decimal point illuminated
Logic "1" } BCD Inputs	2.0 to 5.5V
Logic "0" } DEC	0.0 to 0.8V, sink 1.6 mA
Logic "1" } DEC	Open
Temperature Range	Standard Brightness: 0° to 70° C.
	High Brightness: 0° to 65° C.

socket 501-0702-009 For use with
730-1003, 730-1004, 730-1005 modules

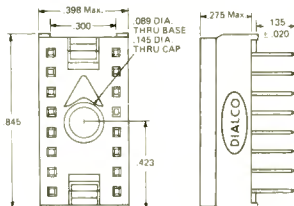

Edge Card Connector 501-0700-005

The printed circuit boards mate with Dialight's 501-0700-005 edge card connector. Holes are provided in each board for hard wiring as an alternate means of connection.

FOR INDIVIDUAL MOUNTING

Modules with or without decoder/driver can be mounted without bezel assembly. The 739 Series bezel display consists of modified 730 Series Diode-Lite readout modules:

Standard Brightness		High Brightness	
Non-Bezel Mtg:	Bezel Mtg. - For use in 739 Assembly	Non-Bezel Mtg.*	Bezel Mtg. - For use in 739 Assembly
730-0002	730-0007	730-1002	730-1007
730-0004	730-0009	730-1004	730-1009
730-0005	730-0010	730-1005	730-1010
730-0011	730-0012	730-1011	730-1012
730-0018	730-0020	730-1018	730-1020
730-0027	730-0029	-	-

Message Modules

-	-	730-1013	730-1014
-	-	730-1015	730-1016
-	-	730-1022	730-1023
-	-	730-1024	730-1025

Also available for use in 739 Series Assemblies:

- 730-0021 Colon— standard brightness only
- 736-0001 Spacer
- 736-0002 Spacer
- 736-0003 Spacer

* See 730 Series Data Sheet in this catalog.

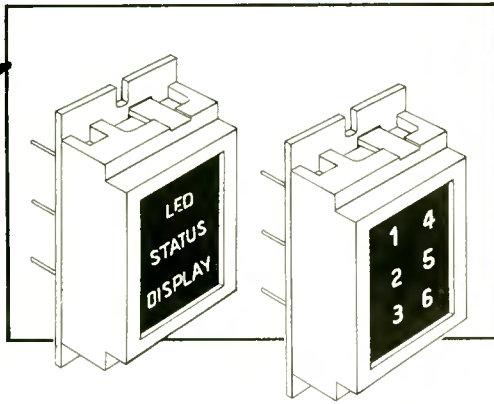

730 series

DIODE-LITE[®] solid state LED Status Display Module
panel or bezel mounting

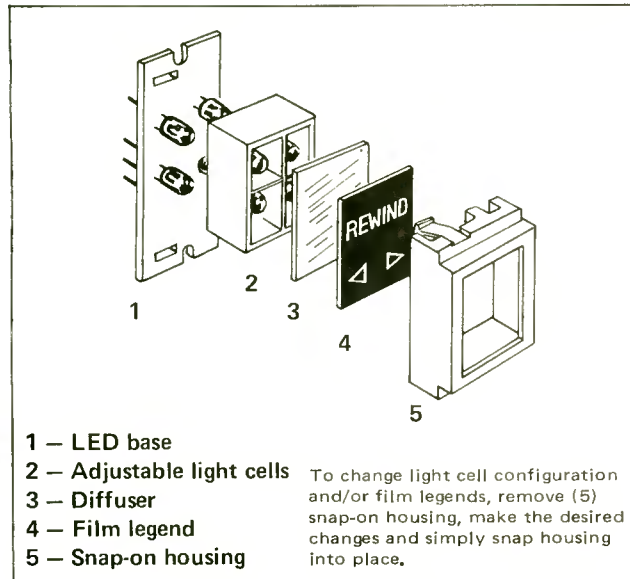

- 1 - LED base
- 2 - Adjustable light cells
- 3 - Diffuser
- 4 - Film legend
- 5 - Snap-on housing

To change light cell configuration and/or film legends, remove (5) snap-on housing, make the desired changes and simply snap housing into place.

Features

- High Brightness LED Light Source
- Legend and cells are interchangeable - snap-together, no tools are required
- Up to six independently illuminated legends
- Compact design - allows for high density status display
- Solid state reliability - life measured in years
- Immune to shock and vibration
- Low power requirements
- Operate with standard IC power supply levels

General Information

The Dialight 730 Series Status Display Module can be panel mounted individually or side by side with standard 730 Series seven segmented numeric readout units in their bezel. The 730 Display Module, like the 730 readout, uses High Brightness light emitting diodes for maximum brightness.

The units are offered with 4 and 6 LEDs to provide the maximum number of options or to provide uniform lighting for all single displays.

Various display configurations may be specified due to adjustable barriers which form individually illuminated light cells. The housing of the unit snaps in place providing access to the legend. This makes it easy for the user to change both the legend and display configuration at a later date.

The 730-1013, 730-1014, 730-1022 and 730-1023 will mount into the 501-0702-009 socket.

The 730-1015, 730-1016, 730-1024 and 730-1025 use the 501-0700-005 Edge Card Connector. Holes are provided in each board for hard wiring as an alternate means of connection.

edge card connector
501-0700-005

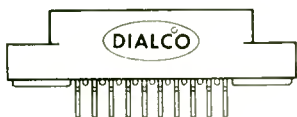

For use with 730-1015, 730-1016*, 730-1024 and 730-1025* display modules.

Socket
501-0702-009

For use with 730-1013, 730-1014*, 730-1022 and 730-1023* display modules.

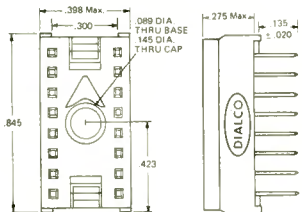

*These displays are designed for bezel mounting only.

Modules for Panel Mounting

		LIGHT CELL LAYOUT
4 LEDs WITH ADJUSTABLE LIGHT CELLS, PROVIDING UP TO 4 LEGENDS		See "Ordering Information"
WITHOUT RESISTORS 730-1013	<p>NOTE: * DECIMALS: ± .007</p>	A B
WITH RESISTORS 730-1015*	<p>NOTE: * DECIMALS: ± .007</p>	C D*
6 LEDs WITH ADJUSTABLE LIGHT CELLS, PROVIDING UP TO 6 LEGENDS		See "Ordering Information"
WITHOUT RESISTORS 730-1022	<p>NOTE: * DECIMALS: ± .007</p>	E J F K
WITH RESISTORS 730-1024*	<p>NOTE: * DECIMALS: ± .007</p>	G L H M

* Printed circuit board can be wired to directly or may be used with Dialight 501-0700-005 or 501-0700-009 printed circuit edge type connector.

Legend Standards

Legend Character Height	Maximum Characters per line	
	Horizontal	Vertical (6 LEDs)
.085"	7	7
.109"	5	6
.141"	4	4

See bezel mounting modules on following page.

Ordering Information

To order status indicator with legend					
specify	for example				
1 - model number ■	730-1013				
2 - light cell layout	B				
3 - legend	<table border="1" style="display: inline-table;"> <tr> <td>Y</td> <td>X</td> </tr> <tr> <td>1</td> <td>2</td> </tr> </table>	Y	X	1	2
Y	X				
1	2				

■ A snap-on non-glare red filter is supplied with each module.

OPERATING CHARACTERISTICS - AMBIENT TEMPERATURE 25° C

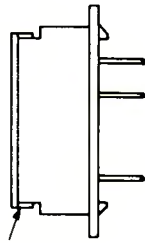
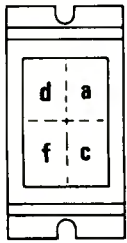

REMOVABLE SNAP-ON RED FILTER

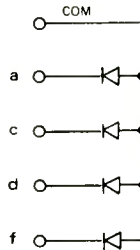

Operating Characteristics

Supply Current	108 mA All Messages Illuminated.
Message Current	27 mA
Message Forward Voltage	2.2 V @ 27 mA
Maximum Message Reverse Voltage	3 V
Temperature Range	0 To 70° C

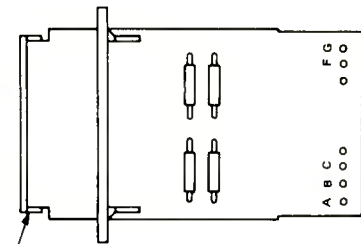
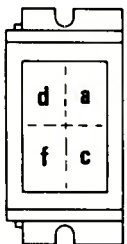

REMOVABLE SNAP-ON RED FILTER

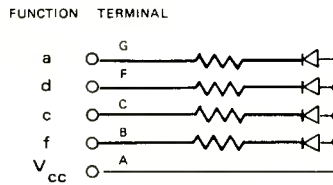

Operating Characteristics

Supply Voltage, V_{cc}	5 ± 0.5 V
Supply Current	108 mA All Messages Illuminated.
Message 'ON'	0.0 To 0.4 V, Sink 27 mA
Message 'OFF'	4.0 To 5.5 V Or Open
Temperature Range	0° To 70° C

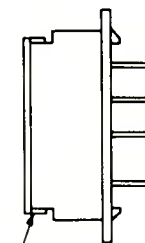
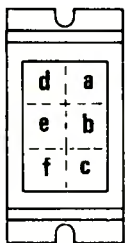

REMOVABLE SNAP-ON RED FILTER

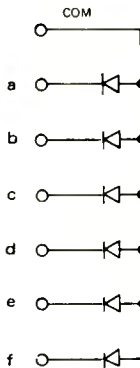

Operating Characteristics

Supply Current	162 mA All Messages Illuminated.
Message Current	27 mA
Message Forward Voltage	2.2 V @ 27 mA
Maximum Message Reverse Voltage	3 V
Temperature Range	0 To 70° C

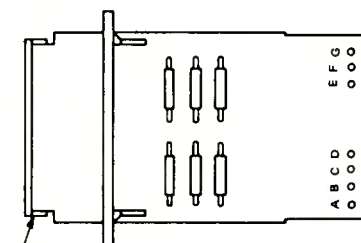
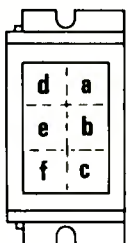

REMOVABLE SNAP-ON RED FILTER

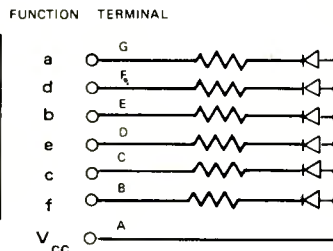

Operating Characteristics

Supply Voltage, V_{cc}	5 ± 0.5 V
Supply Current	162 mA All Messages Illuminated.
Message 'ON'	0.0 To 0.4 V, Sink 27 mA
Message 'OFF'	4.0 To 5.5 V Or Open
Temperature Range	0° To 70° C

730 Series

DIAL-LITE®



solid state LED Status Display Module

Choice of Modules for Individual or Bezel Mounting

730 Series Status Display Modules are available for individual mounting or for bezel mounting. For individual mounting, the 730 series module as described within this catalog sheet should be ordered. When ordering a 739 series assembly, a modified 730 Series Status Display module is used. The chart to the right lists the appropriate part numbers.

Individual Mtg. modules*	Bezel mtg. modules – for use in 739 Assembly **+
730-1013	730-1014
730-1015	730-1016
730-1022	730-1023
730-1024	730-1025

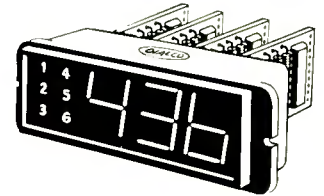

- * See ordering information on preceding page.
- ** See 739 Series Catalog Sheet.
- + Consult table below to specify desired bezel assembly.

Typically, more than one status display module can be mounted in the bezel assembly to serve as status indicator...or the display module(s) may be located anywhere, preceding or intermixed with the digital readouts to indicate specific conditions noted by the numerals.

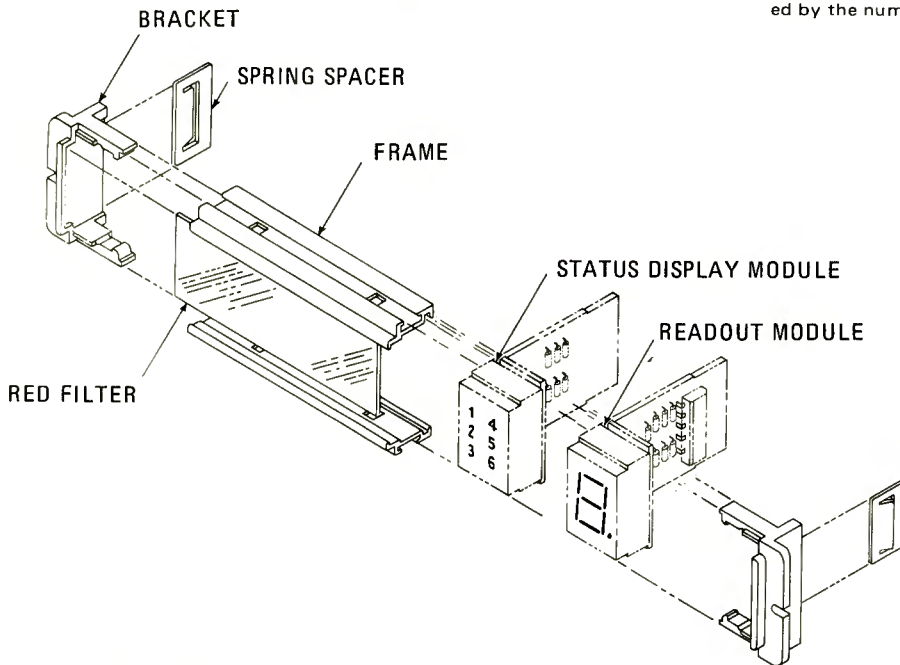

Bezel Assembly Kit

Part Number	Number of Modules	Dimension	
		A	B
733-0002	two	1.587	1.906
733-0003	three	2.275	2.594
733-0004	four	2.963	3.282
733-0005	five	3.651	3.970
733-0006	six	4.339	4.658
733-0007	seven	5.027	5.346
733-0008	eight	5.715	6.034
733-0009	nine	6.403	6.722
733-0010	ten	7.091	7.410

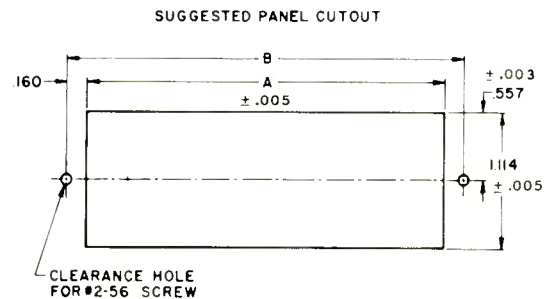

Printed in U.S.A.
Copyright 1974 by Dialight, Brooklyn, N.Y. 11237

Dialight reserves the right to make changes at anytime in order to improve design and to supply the best product possible.

DIALIGHT

A NORTH AMERICAN PHILIPS COMPANY

203 HARRISON PLACE • BROOKLYN, N.Y. 11237 • 212 497-7600 • TWX: 710-584-5487

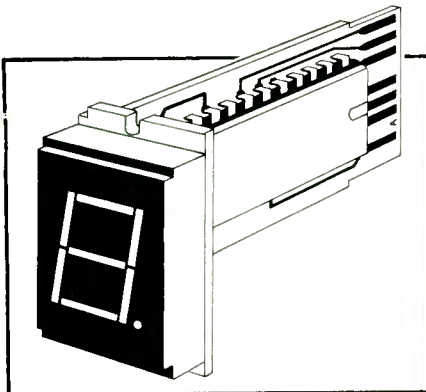

730-0027

DIAL-LITE[®]

solid state LED Readout

with Counter, Latch & Decoder/Driver- with Decimal character height: .625"

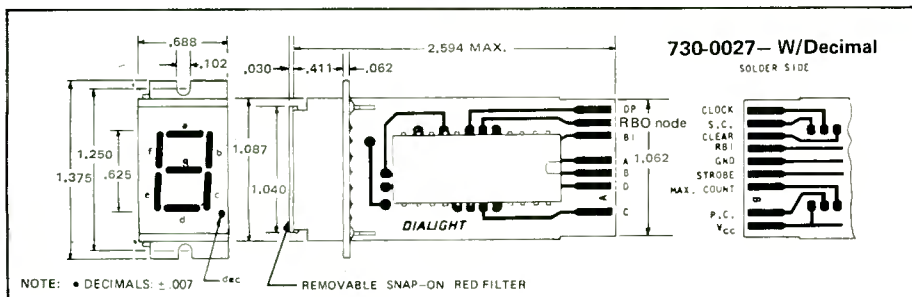

Features

- .625" character
- GaAsP LED
- Single plane - wide angle visibility
- Solid state reliability - life measured in years
- Immune to shock and vibration
- Complete with MSI IC containing counter, latch and decoder/driver
- Reset to zero capability
- Automatic blanking of trailing and/or leading edge zeros
- Overriding blanking for display suppression or pulse modulation of LED brightness

Operating Characteristics (Ambient Temperature 25 °C)

Supply Voltage, Vcc	5 ± 0.25 V
Supply Current	175 mA all segments and decimal point illuminated.
Logic '1' } Clock, Clear, RBI, BI, DP, Strobe, PC Inputs	2.0 to 5.5 V
Logic '0' }	0.0 to 0.8 V, sink 0.8 mA
Logic '1' }	2.0 to 5.5 V
Logic '0' }	0.0 to 0.8 V, sink 1.6 mA
Logic '1' }	2.4 V min., @ 500 μA
Logic '0' }	0.4 V max., sink 2.4 mA
Logic '1' }	2.4 V min., @ 240 μA
Logic '0' }	0.4 V max., sink 4.8 mA
Logic '1' }	2.4 V min., @ 560 μA
Logic '0' }	0.4 V max., sink 11.2 mA
Temperature Range	0° to 70 °C

General Information

This 730 series display module, using a unique lens design (pat. pend.) for maximum light output, presents a bright, highly legible character in a 7 segment format. The display is mounted perpendicularly to a PC board which contains the MSI IC complete with counter, latch and decoder/driver.

The TTL MSI circuits contain the equivalent of 86 gates on a single chip. Logic inputs and outputs are completely TTL/DTL compatible. The buffered inputs are implemented with relatively large resistors in series with the bases of the input transistors to lower drive-current requirements to one-half of that required for a standard Series 54/74 TTL input. The serial-carry inputs, actually two internal loads, is rated as one standard series 54/74 load.

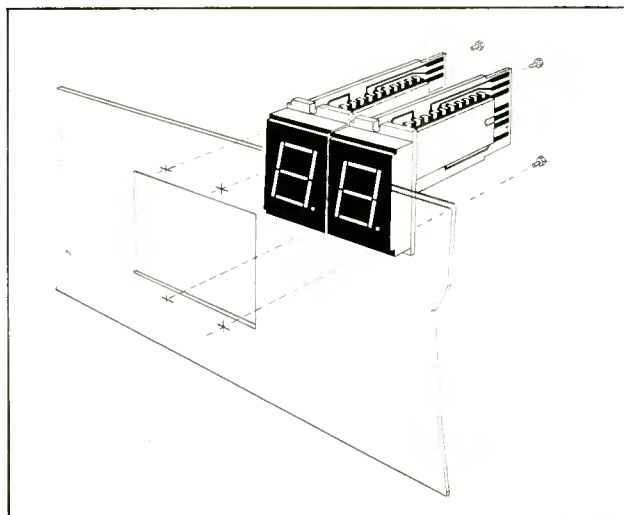

Printed in U.S.A.
Copyright 1974 by Dialight, Brooklyn, N.Y. 11237

Dialight reserves the right to make changes at anytime in order to improve design and to supply the best product possible.



**solid state LED Readout
with Counter, Latch & Decoder/Driver**

TYPICAL APPLICATION DATA

The logic outputs, except the RBO node are active pull-up, and the latch outputs QA, QB, QC and QD are each capable of driving three standard Series 54/74 loads at a low logic level or six loads at a high level while the maximum-count is capable of driving seven 54/74 loads at a low logic level or 14 loads at a high logic level. The RBO node serves as a blanking input with wire-AND-connection, or as a ripple-blanking output supplying ripple-blanking input information for the next decade.

The LED driver outputs are designed specifically to maintain a relatively constant on-level current of approximately 15 mA through LED segments "a" through "g", and seven mA through the decimal point LED.

All inputs are diode-clamped to minimize transmission-line effects, thereby simplifying system design. Maximum clock frequency is typically 18 megahertz and power dissipation is typically 825 milliwatts with all segments on.

The printed circuit board can be wired to directly or may be used with Viking Industries series 2VH10/1J, Continental Connector series K600-121 or Mepco, Inc. series F-061 edge type connectors.

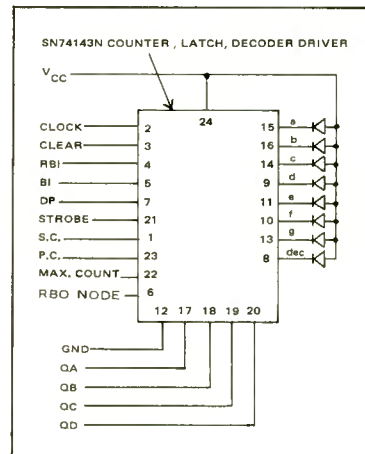

FUNCTION OR CLOCK PULSE	INPUTS							RBO NODE	MAX COUNT	OUTPUTS				TYPICAL DISPLAY	
	CLEAR	STROBE	RBI	BI	DP	SC	PC			LATCHED OUTPUTS	D	C	B		A
BI	X	X	X	1	X	X	X	0	1	0	0	0	0	0	0
CLEAR	0	X	1	0	0	X	X	1	1	0	0	0	0	0	0
CLEAR-DP	0	X	1	0	1	X	X	1	1	0	0	0	0	0	0
CLEAR-RBI	0	X	0	0	X	X	X	0	1	0	0	0	0	0	0
0	1	0	1	0	0	0	0	1	1	0	0	0	0	0	0
1	1	0	1	0	0	0	0	1	1	0	0	0	1	1	1
2	1	0	1	0	0	0	0	1	1	0	0	1	0	2	2
3	1	0	1	0	0	0	0	1	1	0	0	1	1	3	3
4	1	0	1	0	0	0	0	1	1	0	1	0	0	4	4
DP-5	1	0	1	0	1	0	0	1	1	0	1	0	1	5	5
6	1	0	1	0	0	0	0	1	1	0	1	1	0	6	6
7	1	0	1	0	0	0	0	1	1	0	1	1	1	7	7
8	1	0	1	0	0	0	0	1	1	1	0	0	0	8	8
9	1	0	1	0	0	0	0	1	0	1	0	0	1	9	9
RBI-10	1	0	0	0	X	0	0	0	1	0	0	0	0	1	0
11	1	0	1	0	0	0	0	1	1	0	0	1	1	1	1
12	1	0	1	0	0	0	0	1	1	0	0	1	0	2	2
STROBE-13	1	1	X	0	0	0	0	1	1	0	0	1	0	2	2
STROBE-14	1	1	X	0	0	0	0	1	1	0	0	1	0	2	2
15	1	0	1	0	0	0	0	1	1	0	1	0	1	5	5
BI-16	X	X	X	X	X	X	X	0	1	0	0	0	0	0	0
17	1	0	1	0	0	0	0	1	1	0	1	1	1	7	7
SC-18	1	0	1	0	0	1	X	1	1	0	1	1	1	7	7
PC-19	1	0	1	0	0	X	1	1	1	0	1	1	1	7	7

1' = HIGH LEVEL, 0' = LOW LEVEL, 'X' = ANY LEVEL
 * BI/RBO IS WIRE-AND LOGIC SERVING AS AN INPUT AND/OR OUTPUT
 NOTE: THE DECADE COUNTER WILL ADVANCE STATE ON THE POSITIVE GOING EDGE OF THE CLOCK INPUT.



730-0018

DIODE-LITE® solid state LED Readout
with Latch and Decoder/Driver - with Decimal
character height: .625"

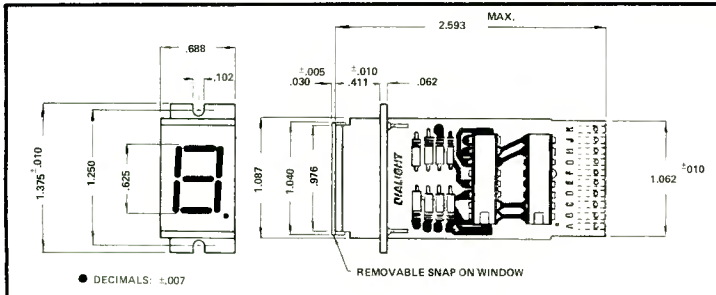
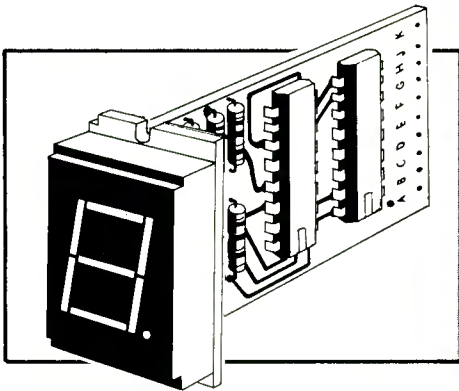

730-0018 — Standard brightness
730-1018 — High brightness

Features

- .625" character with decimal
- GaAsP LED—Standard or high brightness
- Solid state reliability
- Single plane, wide angle visibility
- Virtually immune to shock and vibration
- Compatible with standard IC power supply levels

General Information

This 730 Series display module consists of a Diode-lite readout mounted on a PC board, complete with all necessary current limiting resistors and with decoder/driver and latch. The display features a bright red, highly legible character in a 7 segment format and is virtually immune to shock and vibration.

Four lines in a BCD code are required, which will be transferred and decoded when the clock is high. The resultant display will follow the BCD input data as long as the clock remains high. Terminals are also provided on the PC board to allow automatic blanking of trailing and/or leading edge zeros.

The board may be wired to directly, or may be used with edge card connectors (Dialight P/N 501-0700-005).

DECIMAL OR FUNCTION	INPUTS				* BI/RBO	RESULTANT DISPLAY
	CLOCK	RBI	D	C B A		
0	1	1	0	0 0 0	1	0
1	1	X	0	0 0 1	1	1
2	1	X	0	0 1 0	1	2
3	1	X	0	0 1 1	1	3
4	1	X	0	1 0 0	1	4
5	1	X	0	1 0 1	1	5
6	1	X	0	1 1 0	1	6
7	1	X	0	1 1 1	1	7
8	1	X	1	0 0 0	1	8
9	1	X	1	0 0 1	1	9
BI	X	X	X	X X X	0	
RBI	1	0	0	0 0 0	0	

*1' = HIGH LEVEL, '0' = LOW LEVEL 'X' = ANY LEVEL
* BI/RBO IS WIRE-AND LOGIC SERVING AS AN INPUT AND/OR OUTPUT

Operating Characteristics (Ambient Temperature 25° C)

Supply Voltage, V _{CC}	5 ± 0.25 v
Supply Current	Standard brightness 215 mA all segments illuminated 232 mA all segments & decimal point illuminated High brightness 254 mA all segments illuminated 281 mA all segments & decimal point illuminated
Logic '1'	BCD Inputs 2.0 TO 5.5 V
Logic '0'	
Logic '1'	Clock 2.0 TO 5.5 V
Logic '0'	
Logic '1'	DEC. OPEN
Logic '0'	
Temperature Range	0° TO 70° C

Note: The BCD input data will be transferred and decoded when the clock is high. The resultant display will follow the BCD input data as long as the clock remains high.

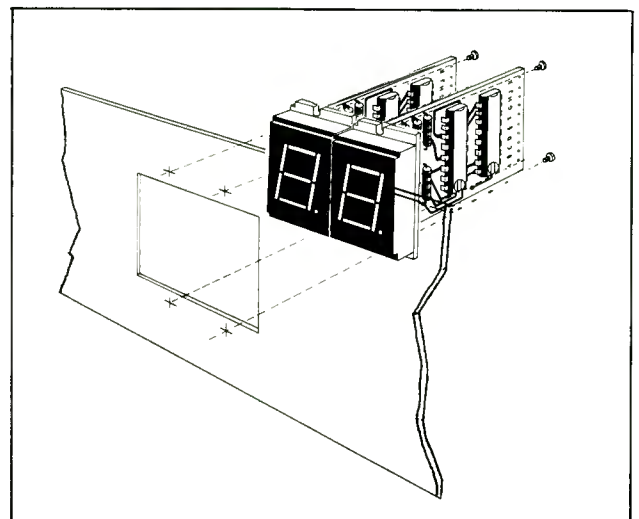

Printed in U.S.A.
Copyright 1974 by Dialight, Brooklyn, N.Y. 11237

Dialight reserves the right to make changes at anytime in order to improve design and to supply the best product possible.



203 HARRISON PLACE • BROOKLYN, N.Y. 11237 • 212 497-7600 • TWX: 710-584-5487

A NORTH AMERICAN PHILIPS COMPANY

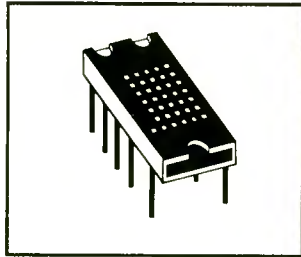

745-0005

solid state LED

DIODE-LITE® 5x7 Dot Matrix Alpha-Numeric Display

character height: .300"

The display is made of Gallium Arsenide Phosphide and is mounted on a 14 pin dual in-line substrate and cast within an electrically nonconductive transparent epoxy.

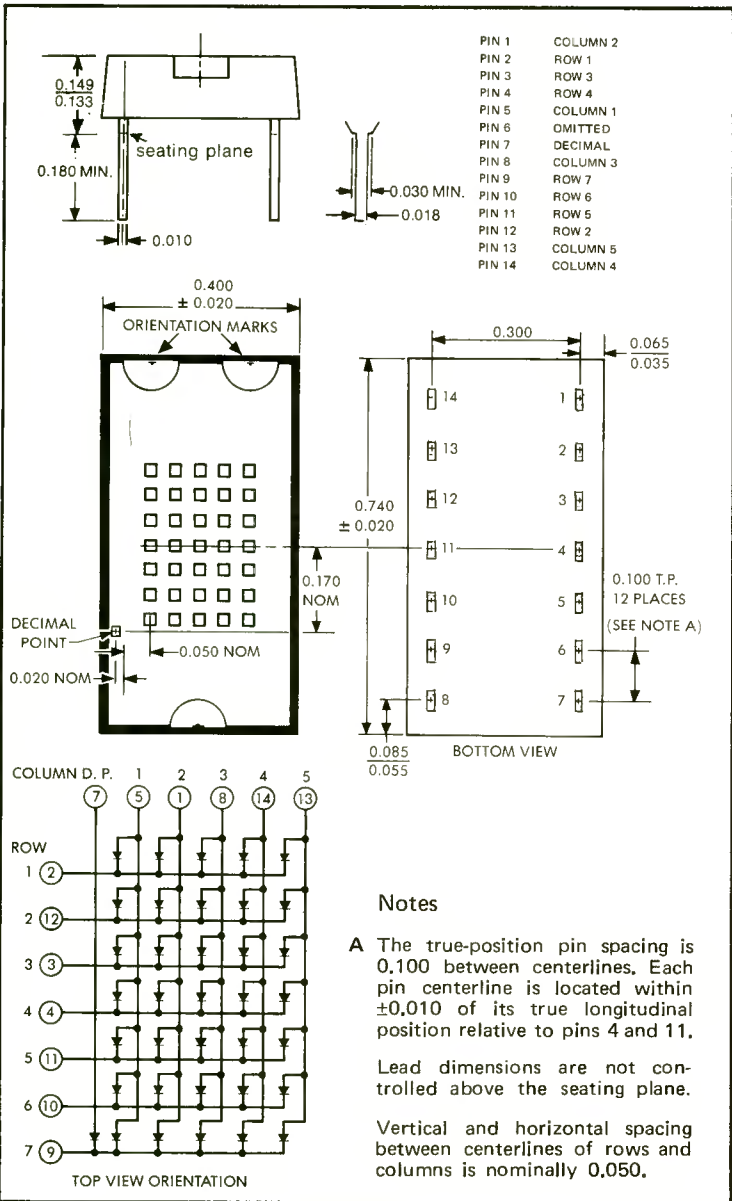

features

- Solid state visible display with clear transparent plastic encapsulation
- 0.3 inch high character
- High brightness
- Low power requirements
- Single-plane, wide-angle visibility
- 5x7 Array with X-Y select and decimal
- Compatible with USASCII and EBCDIC codes
- Includes decimal point
- Displays available in a bezel assembly without decoder/driver (series 749-0800)
- Drive circuitry available upon request.

socket 501-0701-009

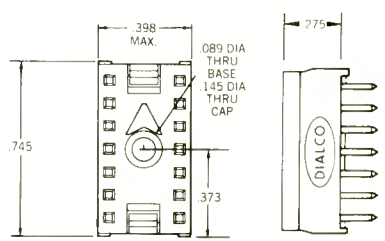

For use with 745-0005 5x7 alpha-numeric display.

red window 742-0002



For use with up to ten display modules. When ordered with 745-0005 displays, the price is .97 each.

Window not shown actual size

Printed in U.S.A.
 Copyright 1974 by Dialight, Brooklyn, N.Y. 11237

Dialight reserves the right to make changes at anytime in order to improve design and to supply the best product possible.



203 HARRISON PLACE • BROOKLYN, N.Y. 11237 • 212 497-7600 • TWX: 710-584-5487

operating specifications 745-0005

absolute maximum ratings

Reverse Voltage at 25°C Ambient	3 V
Peak Forward Current, Each Diode (See Note 1)	100 mA
Continuous Forward Current:	
Each Diode	20 mA
Total	400 mA
Average Power Dissipation Total Package	750 mW
Ambient Temperature Range	0°C to 70°C
Storage Temperature Range	-55°C to 100°C

NOTE 1: This value applies for pulse width ≤ 50 μ s, duty cycle $\leq 20\%$.

operating characteristics of each diode 25°C ambient temperature (unless otherwise noted)

PARAMETER	TEST CONDITIONS	MIN	TYP	MAX	UNIT
B Luminance		200	300		fL
λ_{peak} Wavelength at Peak Emission	$I_F = 10$ mA	6300	6500	6700	\AA
BW_{λ} Spectral Bandwidth between Half-Power Points		200			\AA
V_F Static Forward Voltage		1.5	1.6	1.75	V
αV_F Average Temperature Coefficient of Static Forward Voltage	$I_F = 10$ mA, $T_A = 0^\circ\text{C}$ to 70°C		-1.4		mV/ $^\circ\text{C}$
I_R Static Reverse Current	$V_R = 3$ V			100	μA
C Anode-to-Cathode Capacitance	$V_R = 0$, $f = 1$ MHz		80		pF

typical characteristics

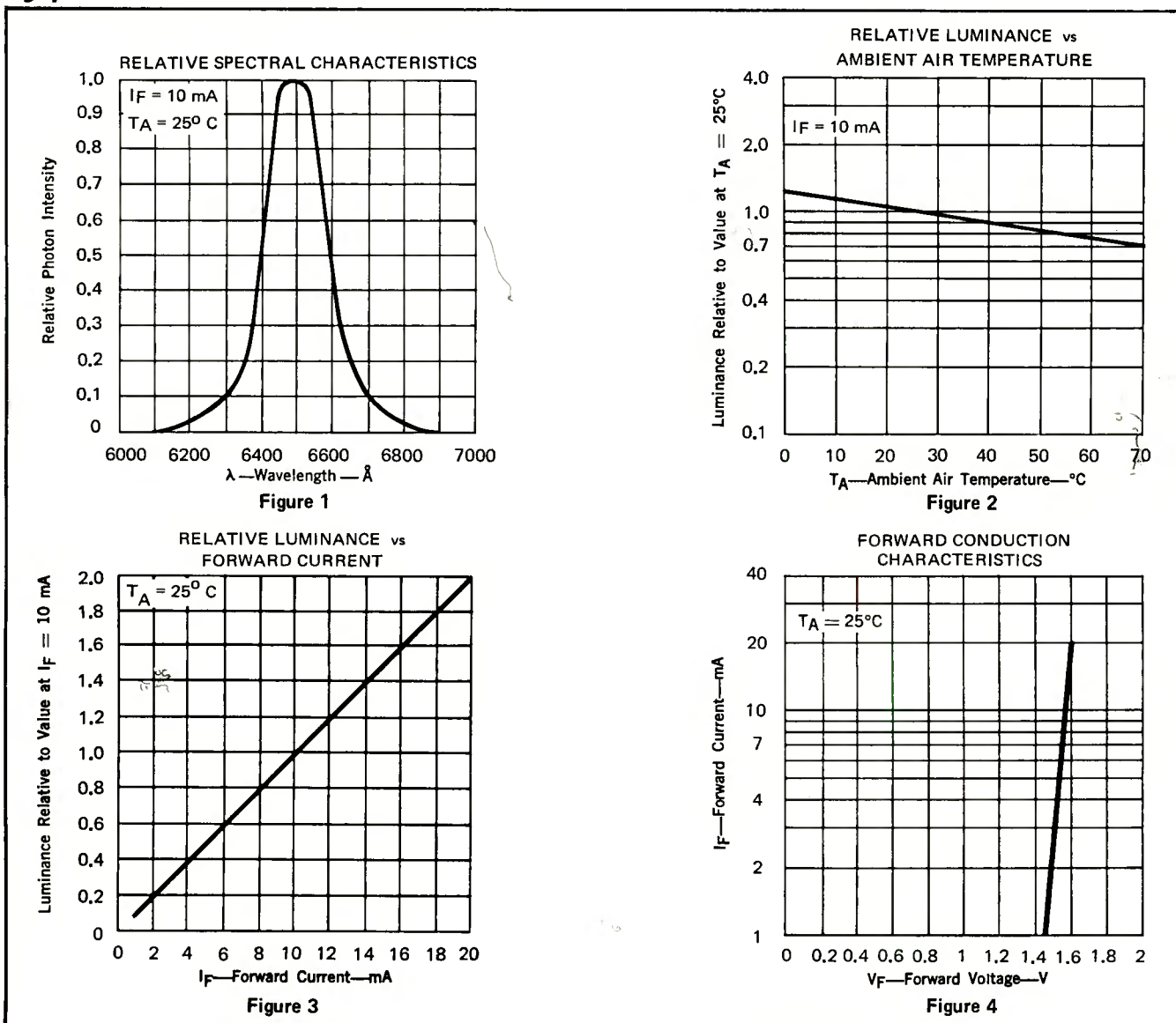

typical application data 745-0005

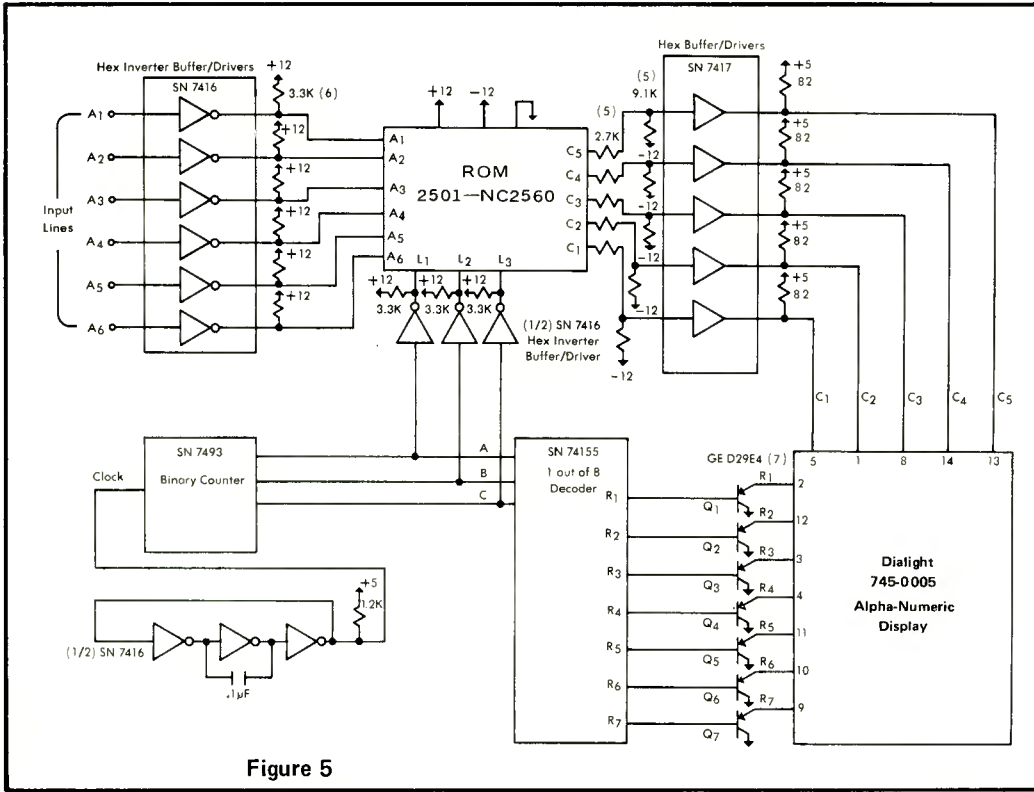

Figure 5

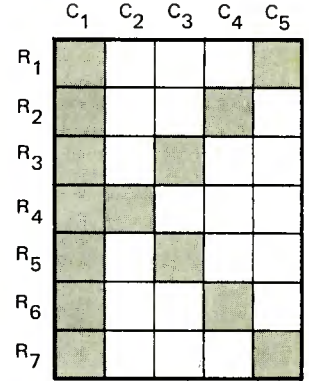

Figure 6

A ₆	A ₅	A ₄	A ₃	A ₂	A ₁	Resultant Display	A ₆	A ₅	A ₄	A ₃	A ₂	A ₁	Resultant Display
0	0	0	0	0	0	@	1	0	0	0	0	0	
0	0	0	0	0	1	A	1	0	0	0	0	1	
0	0	0	0	1	0	B	1	0	0	0	1	0	"
0	0	0	0	1	1	C	1	0	0	0	1	1	#
0	0	0	1	0	0	D	1	0	0	1	0	0	\$
0	0	0	1	0	1	E	1	0	0	1	0	1	%
0	0	0	1	1	0	F	1	0	0	1	1	0	&
0	0	0	1	1	1	G	1	0	0	1	1	1	'
0	0	1	0	0	0	H	1	0	1	0	0	0	(
0	0	1	0	0	1	I	1	0	1	0	0	1)
0	0	1	0	1	0	J	1	0	1	0	1	0	*
0	0	1	0	1	1	K	1	0	1	0	1	1	+
0	0	1	1	0	0	L	1	0	1	1	0	0	,
0	0	1	1	0	1	M	1	0	1	1	0	1	-
0	0	1	1	1	0	N	1	0	1	1	1	0	.
0	0	1	1	1	1	O	1	0	1	1	1	1	/
0	1	0	0	0	0	P	1	1	0	0	0	0	∅
0	1	0	0	0	1	Q	1	1	0	0	0	1	1
0	1	0	0	1	0	R	1	1	0	0	1	0	2
0	1	0	0	1	1	S	1	1	0	0	1	1	3
0	1	0	1	0	0	T	1	1	0	1	0	0	4
0	1	0	1	0	1	U	1	1	0	1	0	1	5
0	1	0	1	1	0	V	1	1	0	1	1	0	6
0	1	0	1	1	1	W	1	1	0	1	1	1	7
0	1	1	0	0	0	X	1	1	1	0	0	0	8
0	1	1	0	0	1	Y	1	1	1	0	0	1	9
0	1	1	0	1	0	Z	1	1	1	0	1	0	:
0	1	1	0	1	1	[1	1	1	0	1	1	;
0	1	1	1	0	0	\	1	1	1	1	0	0	<
0	1	1	1	0	1]	1	1	1	1	0	1	=
0	1	1	1	1	0	^	1	1	1	1	1	0	>
0	1	1	1	1	1	_	1	1	1	1	1	1	?

Figure 7 - Resultant displays of alpha-numeric device in conjunction with the ASCII ROM.

The alpha-numeric display with its driving circuitry is illustrated in Figure 5. The character displayed is a function of six input lines A₁ through A₆. The seven rows are scanned sequentially one at a time. The timing is controlled by the clock which drives a binary counter, whose outputs ABC control the row to be selected. This ensures that the read-only-memory's (ROM) five outputs C₁-C₅ correspond to the row of dots which are enabled by the 1 out of 8 decoder. The SN74155 is a dual 2 to 4 line decoder, used here as a 1 out of 8 decoder.

For example, let's assume that the letter K is to be displayed. K in a 5x7 array of dots looks as depicted in Figure 6. The ASCII code A₁-A₆ for selecting K is 001011. The SN7416 inverter buffer/drivers and the SN7417 buffer/driver are used to interface the inputs and outputs of the ROM. The binary counter's outputs ABC continuously cycle from 000 to 111 and back to 000. When ABC equals 000, then through the row inputs L₁, L₂, L₃ the ROM outputs C₁ and C₅ will be "high" and C₂, C₃, and C₄ will be "low" as shown in Figure 6. Simultaneously the 1 out of 8 decoder drives Q₁ "on" and this enables the first and fifth dots of the first row to be illuminated. On the next clock pulse, the counter advances to 001. C₁ and C₄ will become "high" and Q₂ will be driven "on" thereby illuminating the first and fourth dots of the second row. This process is continued and repeated rapidly, so that the final result appears to be the letter K.

The 745-0005 in conjunction with any suitable ASCII ROM will display 64 alpha-numeric characters. These are shown in Figure 7 as a function of the six bit inputs A₁-A₆.

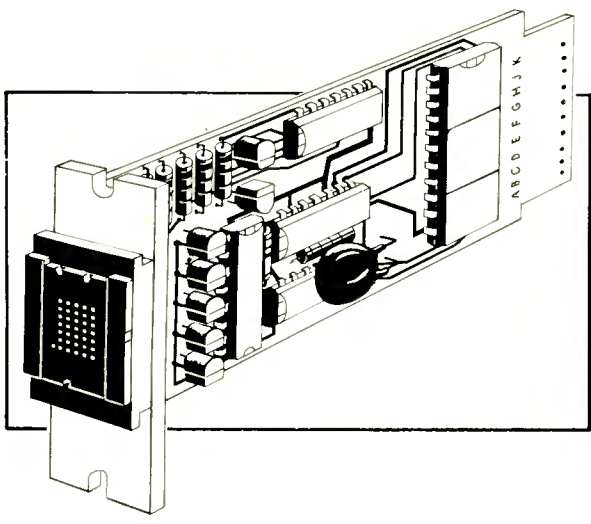

740-0018
DIALIGHT®
Alpha-Numeric Display
 with 64 ASC II Code Generator
 character height: .300"

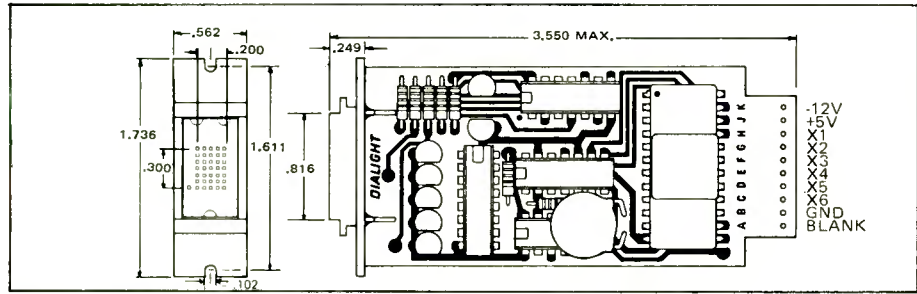

Features

- .300" high character
- Single plane wide angle visibility
- High Brightness
- 5 x 7 matrix array
- Includes decimal point
- Long life, shock resistant
- Self contained character generator to display 64 ASCII characters

Operating Characteristics (Ambient Temperature 25° C)

Supply Voltage, V _{CC}	5 ± 0.25 V
Supply Voltage, V _{GG}	- 12 ± 1 V
Supply Current, I _{CC}	240 mA All dots illuminated 310 mA All dots blanked
Supply Current, I _{GG}	- 16 mA
Logic '1' Inputs	3.5 V Min. @ V _{CC} = 5 V 3.75 V Min. @ V _{CC} = 5.25 V 1.0 V Max. @ V _{CC} = 5 V 0.75 V Max. @ V _{CC} = 4.75 V
Logic '0' Inputs	
Logic '1' Blank Input	2.0 to 5.5 V
Logic '0' Blank Input	0.0 to 0.8 V, Sink 0.8 mA



Edge Card Connector 501-0700-005 — with flat solder blade terminals.
 501-0700-009 — with PC terminals.
 The printed circuit boards mate with Diallight's 501-0700-005 and 501-0700-009 edge card connectors. Holes are provided in each board for hard wiring as an alternate means of connection.
 Caution should be exercised during direct soldering to avoid damage to board fingers.

General Information

The 740-0018 is a 5 x 7 dot matrix alpha-numeric module complete with character generator to display 64 ASCII characters. The character displayed is a function of six input lines, X1 through X6 as shown in the block diagram below (Fig.A). The 7 rows of the display are scanned sequentially, one at a time. Timing is controlled by the clock which drives a binary counter, whose outputs control the row to be selected. This insures that the character generator's 5 outputs, C1-C5, correspond to the row of dots which are enabled by the 1 out of 8 decoder.

X6 X5 X4 X3 X2 X1	Resultant Display	X6 X5 X4 X3 X2 X1	Resultant Display
0 0 0 0 0 0	@	1 0 0 0 0 0	0
0 0 0 0 0 1	A	1 0 0 0 0 1	1
0 0 0 0 1 0	B	1 0 0 0 1 0	"
0 0 0 0 1 1	C	1 0 0 0 1 1	#
0 0 0 1 0 0	D	1 0 0 1 0 0	\$
0 0 0 1 0 1	E	1 0 0 1 0 1	%
0 0 0 1 1 0	F	1 0 0 1 1 0	&
0 0 0 1 1 1	G	1 0 0 1 1 1	'
0 0 1 0 0 0	H	1 0 1 0 0 0	{
0 0 1 0 0 1	I	1 0 1 0 0 1	}
0 0 1 0 1 0	J	1 0 1 0 1 0	*
0 0 1 0 1 1	K	1 0 1 0 1 1	+
0 0 1 1 0 0	L	1 0 1 1 0 0	,
0 0 1 1 0 1	M	1 0 1 1 0 1	-
0 0 1 1 1 0	N	1 0 1 1 1 0	.
0 0 1 1 1 1	O	1 0 1 1 1 1	/
0 1 0 0 0 0	P	1 1 0 0 0 0	φ
0 1 0 0 0 1	Q	1 1 0 0 0 1	1
0 1 0 0 1 0	R	1 1 0 0 1 0	2
0 1 0 0 1 1	S	1 1 0 0 1 1	3
0 1 0 1 0 0	T	1 1 0 1 0 0	4
0 1 0 1 0 1	U	1 1 0 1 0 1	5
0 1 0 1 1 0	V	1 1 0 1 1 0	6
0 1 0 1 1 1	W	1 1 0 1 1 1	7
0 1 1 0 0 0	X	1 1 1 0 0 0	8
0 1 1 0 0 1	Y	1 1 1 0 0 1	9
0 1 1 0 1 0	Z	1 1 1 0 1 0	:
0 1 1 0 1 1	[1 1 1 0 1 1	:
0 1 1 1 0 0	\	1 1 1 1 0 0	<
0 1 1 1 0 1]	1 1 1 1 0 1	=
0 1 1 1 1 0	^	1 1 1 1 1 0	>
0 1 1 1 1 1	_	1 1 1 1 1 1	?

Resultant displays of alpha-numeric device in conjunction with the ASCII ROM.
 Printed in U.S.A.
 Copyright 1974 by Diallight, Brooklyn, N.Y. 11237

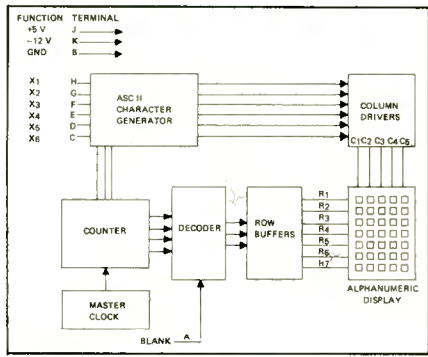
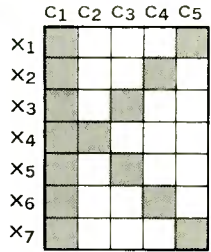
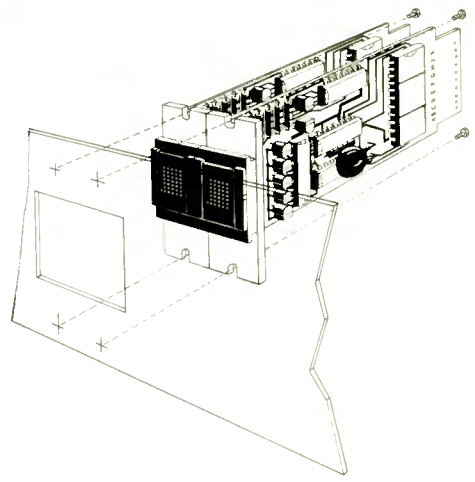

Figure A



Diallight reserves the right to make changes at anytime in order to improve design and to supply the best product possible.



745-0006

DIALCO
DIALCO-LITE[®]

solid state LED Readout
character height .270"

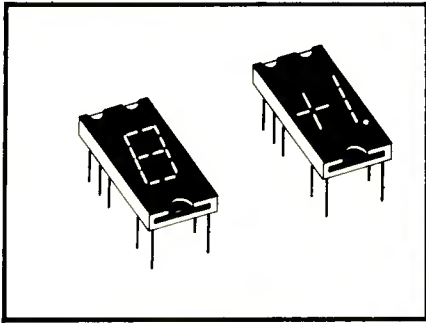

features

- .270" high characters
- Gallium Arsenide Phosphide light source
- High brightness
- Low power requirements
- Standard 14 pin DIP
- Available with left or right decimal
- Single-plane wide angle visibility
- Compatible with most TTL and DTL circuits
- Each unit visually checked for uniformity of elements

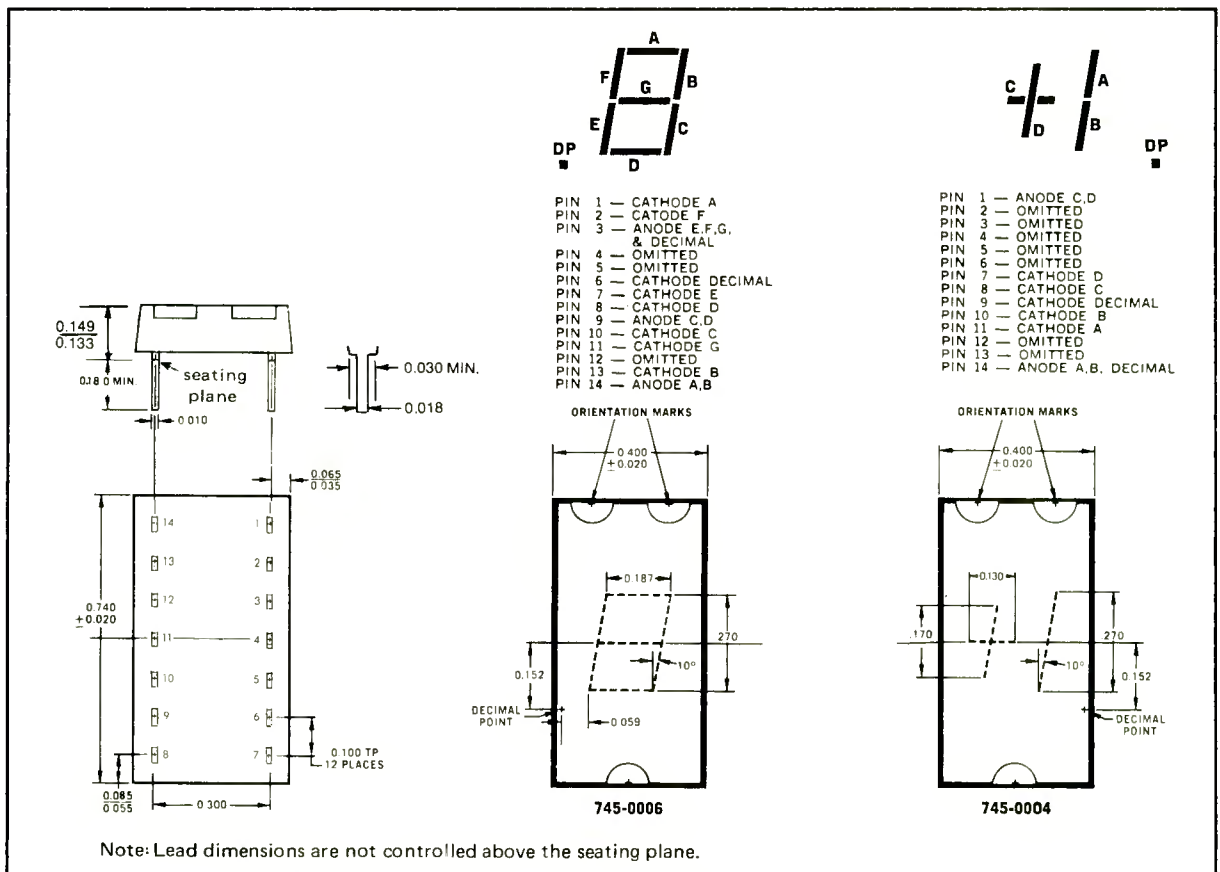

connector 501-0701-009

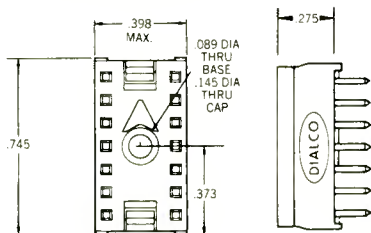

For use with 745-0004 and 745-0006 readouts.

decoder/driver 704-1549

NOTE:
Leads are for insertion in hole rows on .300" centers. They are purposely shipped with .350" spacing in order to provide sufficient tension necessary to secure the package in the board during soldering.

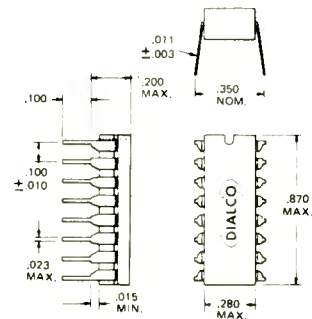

operating specifications 745-0006

absolute maximum ratings

Reverse Voltage at 25°C Ambient	
Each Segment	6 V
Decimal Point	3 V
Peak Forward Current, Each Segment or Decimal Point (See Note 1)	75 mA
Continuous Forward Current:	
Each Segment or Decimal Point	30 mA
Total for 745-0006	240 mA
Total for 745-0004	150 mA
Ambient Temperature Range	0°C to 70°C

Note 1: For PRR \geq 60 Hz, duty cycle \leq 14%.

operating characteristics of each segment at 25°C ambient temperature (unless otherwise noted)

PARAMETER	TEST CONDITIONS	MIN	TYP	MAX	UNIT
B Luminance	IF = 20 mA	200	550		fL
λ_{peak} Wavelength at Peak Emission		6300	6500	6700	Å
BW_{λ} Spectral Bandwidth between Half-Power Points			200		Å
VF Static Forward Voltage		3	3.2	3.5	V
αVF Average Temperature Coefficient of Static Forward Voltage	IF = 20 mA, TA = 0°C to 70°C		-2.7		mV/°C
IR Static Reverse Current	VR = 6 V			100	µA
C Anode-to-Cathode Capacitance	VR = 0, f = 1 MHz		85		pF

* for decimal point:

Parameter	min	typ	max	unit
VF	1.5	1.6	1.75	V
αVF		-1.4		mV/°C
C		120		pF

typical characteristics

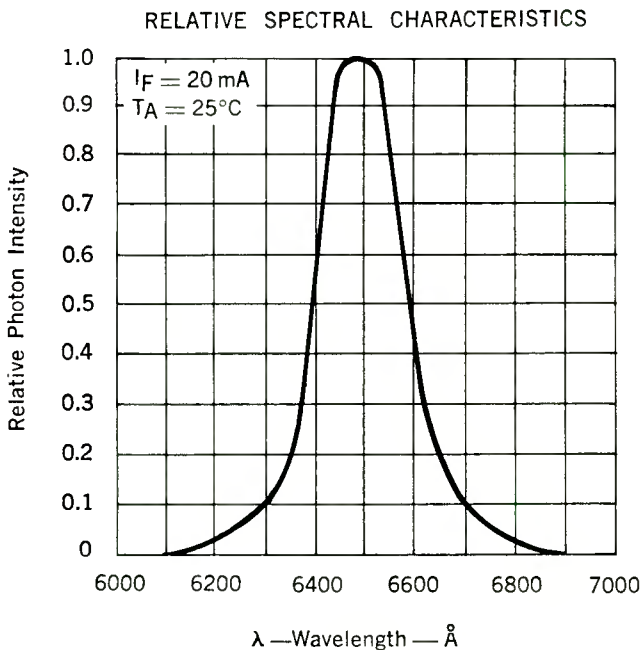

FIGURE 1

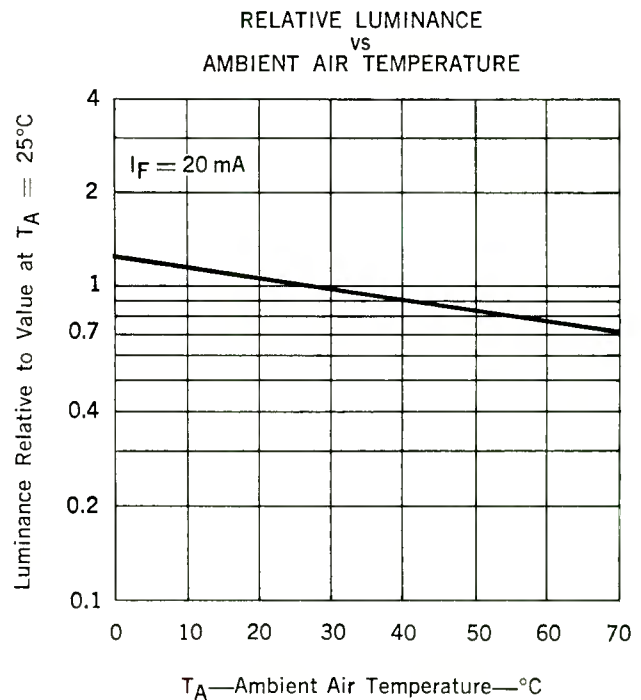
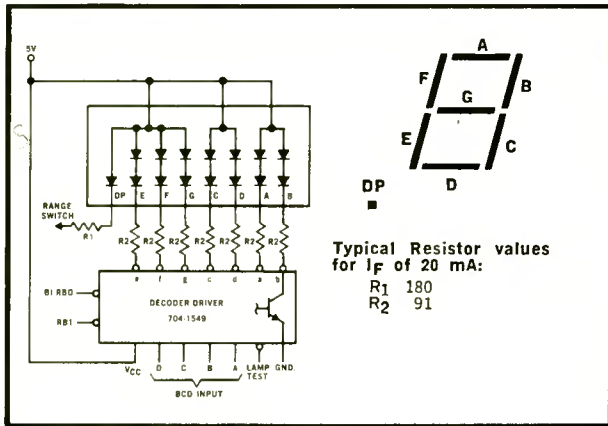

FIGURE 2

typical application data 745-0006



NOTES:

1. The blanking input (BI) must be open or held at a high logic level when output functions 0 through 15 are desired. The ripple-blanking input (RBI) must be open or high if blanking of a decimal zero is not desired.
2. When a low logic level is applied directly to the blanking input (BI), all segment outputs are off regardless of any other input.
3. When the ripple blanking input (RBI) and inputs A, B, C, and D are at low logic level with the lamp test input high, all segment outputs are off and the ripple-blanking output (RBO) of the decoder goes to a low level (response condition).
4. When the blanking input/ripple blanking output (BI/RBO) is open or held high and a low is applied to the lamp-test input, all segments are illuminated.

truth table

DECIMAL OR FUNCTION	INPUTS					BI/RBO†	NOTE	
	LT	RBI	D	C	B			A
0	H	H	L	L	L	L	H	1
1	H	X	L	L	L	H	H	1
2	H	X	L	L	H	L	H	1
3	H	X	L	L	H	H	H	1
4	H	X	L	H	L	L	H	1
5	H	X	L	H	L	H	H	1
6	H	X	L	H	H	L	H	1
7	H	X	L	H	H	H	H	1
8	H	X	H	L	L	L	H	1
9	H	X	H	L	L	H	H	1
10	H	X	H	L	H	L	H	1
11	H	X	H	L	H	H	H	1
12	H	X	H	H	L	L	H	1
13	H	X	H	H	L	H	H	1
14	H	X	H	H	H	L	H	1
15	H	X	H	H	H	H	H	1
BI	X	X	X	X	X	X	L	2
RBI	H	L	L	L	L	L	L	3
LT	L	X	X	X	X	X	H	4

H = high level (logical 1 in positive logic), L = low level (logical 0 in positive logic), X = irrelevant.

†BI/RBO is wire-AND logic serving as blanking input (BI) and/or ripple-blanking output (RBO).

Resultant displays for above truth table

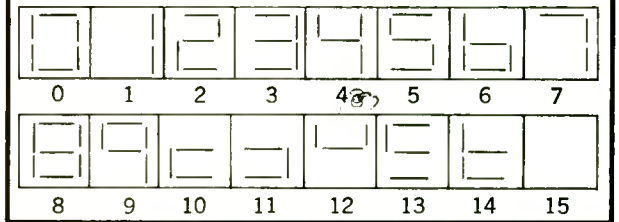

typical characteristics

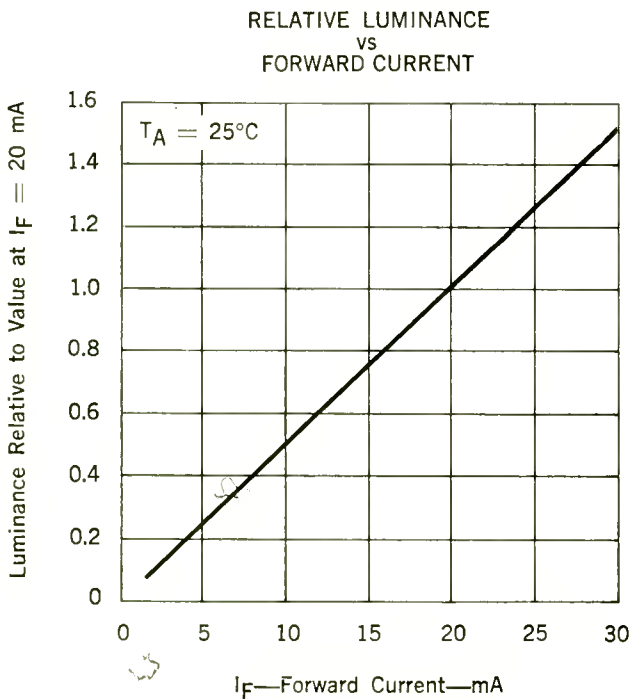

FIGURE 3

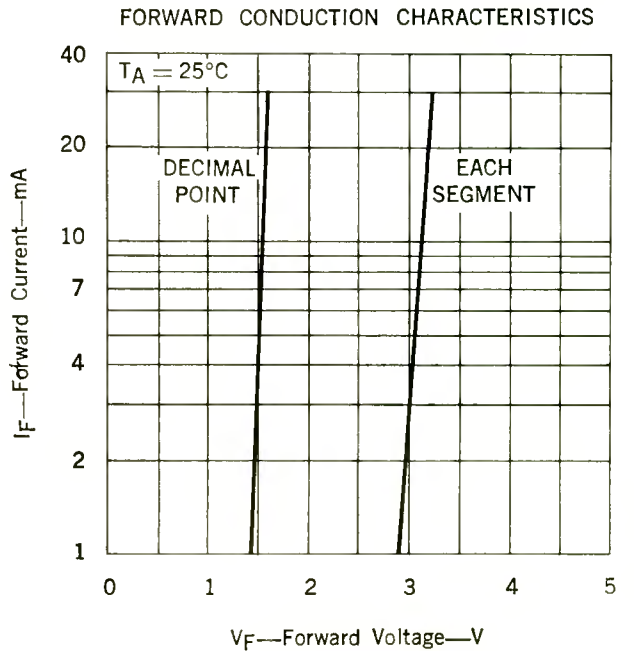
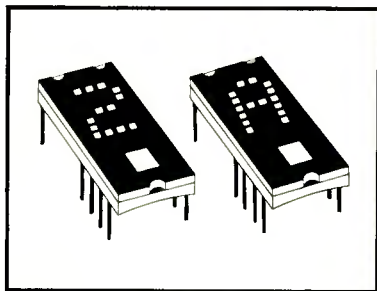

FIGURE 4

745-0007

DIALCO[®] DIAL-LITE[®] Solid State LED
Hexadecimal display with logic
character height: .270"



The display and TTL MSI chip are mounted on a lead-frame assembly which is then cast within a red, electrically nonconductive, transparent plastic compound. Multiple displays may be mounted on 0.450-inch centers.

mechanical data

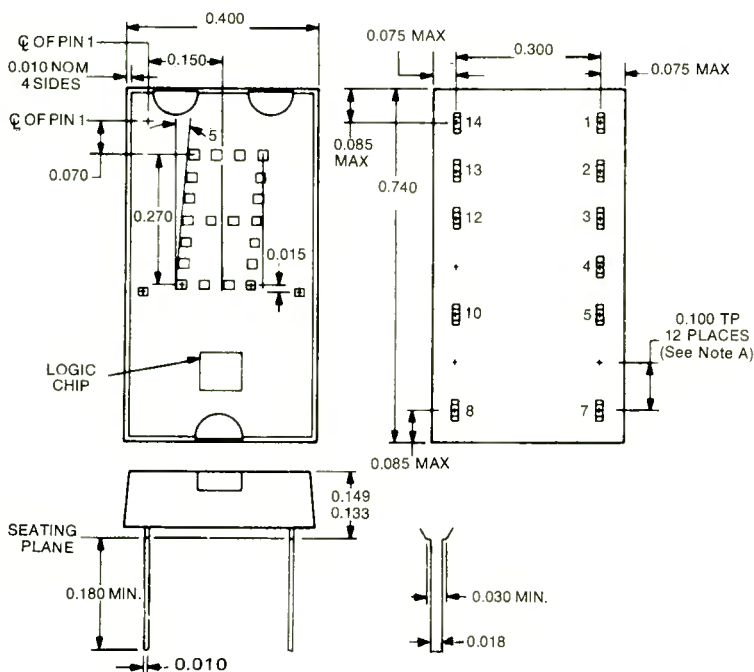

NOTES:

- A. The true position pin spacing is 0.100 between centerlines. Each pin centerlines is located within ± 0.010 of its true longitudinal position relative to pins 1 and 14.
- B. Lead dimensions are not controlled above the seating plane.
- C. Dimensions associated with position of LED's are between centerlines and are nominal.
- D. All dimensions are in inches unless otherwise specified.

- PIN 1 LED SUPPLY VOLTAGE
- PIN 2 LATCH DATA INPUT B
- PIN 3 LATCH DATA INPUT A
- PIN 4 LEFT DECIMAL POINT CATHODE
- PIN 5 LATCH STROBE INPUT
- PIN 6 OMITTED
- PIN 7 COMMON GROUND
- PIN 8 BLANKING INPUT
- PIN 9 OMITTED
- PIN 10 RIGHT DECIMAL POINT CATHODE
- PIN 11 OMITTED
- PIN 12 LATCH DATA INPUT D
- PIN 13 LATCH DATA INPUT C
- PIN 14 LOGIC SUPPLY VOLTAGE, V_{CC}

Solid-State Visible Hexadecimal Display
With Integral TTL Circuit To Accept,
Store, And Display 4-Bit Binary Data

- 0.270-Inch-High Character
- High Brightness
- Left-and-Right-Hand Decimals
- Separate LED and Logic Power Supplies May Be Used
- Easy System Interface
- Single-Plane Wide-Angle Visibility
- Internal TTL MSI Chip with Latch, Decoder, and Driver
- Operates from 5-Volt or 6-Volt Supply
- Constant-Current Drive for Hexadecimal Characters

connector 501-0701-009

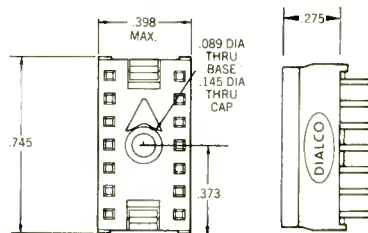

For use with 745-0007 display.

description 745-0007

This hexadecimal display contains a four-bit latch, decoder, driver, and 4x7 light-emitting-diode (LED) character with two externally-driven decimal points in a 14-pin package. A description of the functions of the inputs of this device follows.

	PIN NO.	DESCRIPTION
LATCH STROBE INPUT	5	When low, the data in the latches follow the data on the latch data inputs. When high, the data in the latches will not change. If the display is blanked and then restored while the enable input is high, the previous character will again be displayed.
BLANKING INPUT	8	When high, the display is blanked regardless of the levels of the other inputs. When low, a character is displayed as determined by the data in the latches. The blanking input may be pulsed for intensity modulation.
LATCH DATA INPUTS (A, B, C, D)	3, 2, 13, 12	Data on these inputs are entered into the latches when the enable input is low. The binary weights of these inputs are A = 1, B = 2, C = 4, D = 8.
DECIMAL POINT CATHODES	4, 10	These LEDs are not connected to the logic chip. If a decimal point is used, an external resistor or other current-limiting mechanism must be connected in series with it.
LED SUPPLY	1	This connection permits the user to save on regulated V_{CC} current by using a separate LED supply, or it may be externally connected to the logic supply (V_{CC}).
LOGIC SUPPLY (V_{CC})	14	Separate V_{CC} connection for the logic chip.
COMMON GROUND	7	This is the negative terminal for all logic and LED currents except for the decimal points.

The LED driver outputs are designed to maintain a relatively constant on-level current of approximately five milliamperes through each of the LED's forming the hexadecimal character. This current is virtually independent of the LED supply voltage within the recommended operating conditions. Drive current varies with changes in logic supply voltage resulting in a change in luminous intensity as shown in Figure 2. The decimal point anodes are connected to the LED supply; the cathodes are connected to external pins. Since there is no current limiting built into the decimal point circuits, this must be provided externally if the decimal points are used.

The TTL MSI chip is specially designed with a wider supply voltage range than standard Series 54/74 circuits so that it will operate from either a five-volt or a six-volt power supply.

The resultant displays for the values of the binary data in the latches are as shown below.

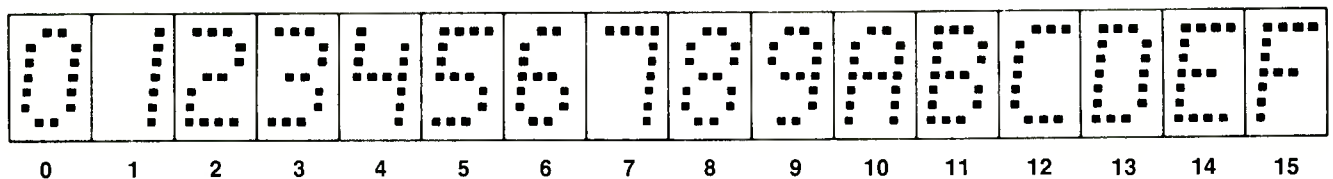

description 745-0007

functional block diagram

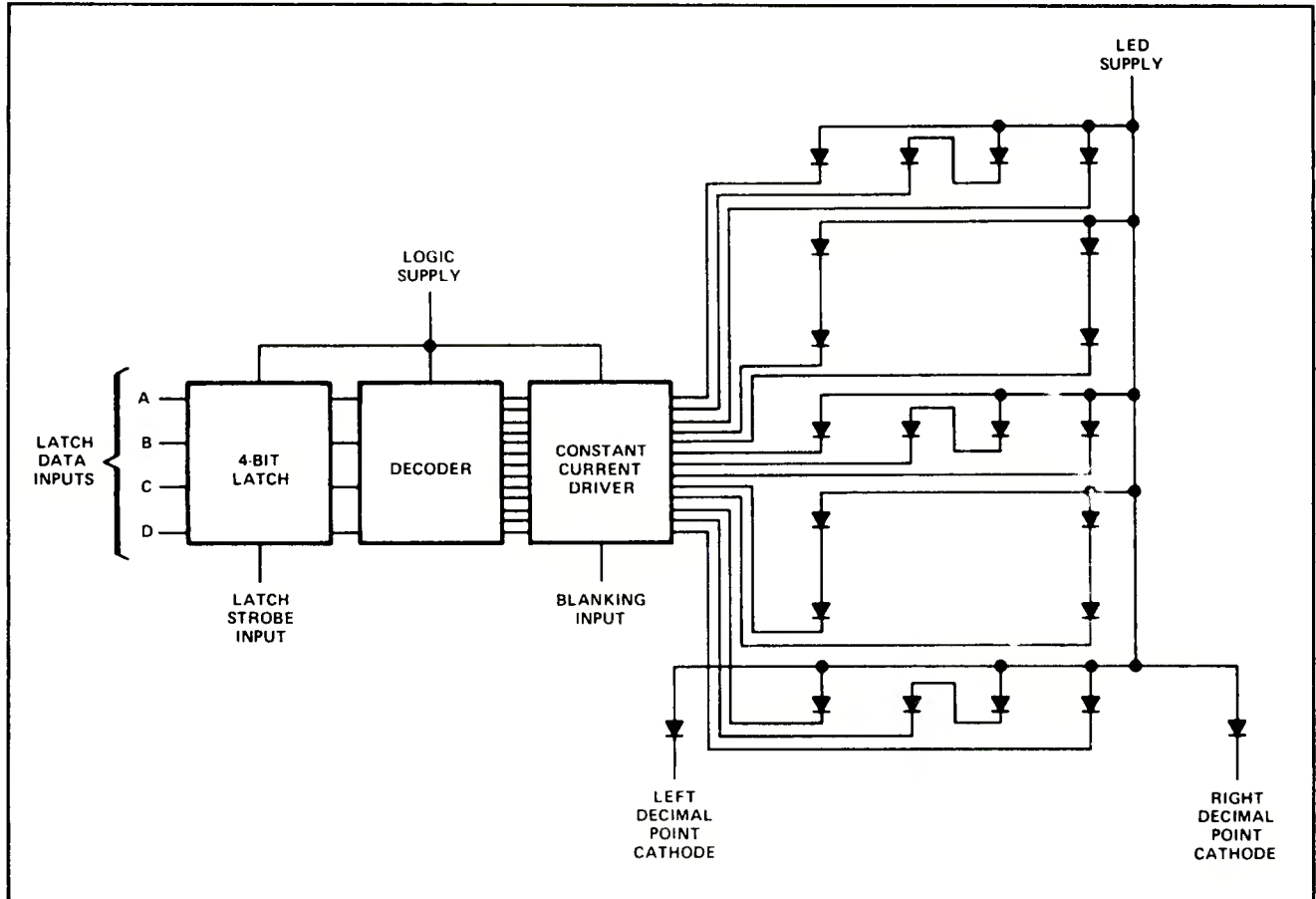

absolute maximum ratings over operating ambient-air temperature range (unless otherwise noted)

Logic Supply Voltage, V_{CC} (See Note 1)	7V
LED Supply Voltage (See Note 1)	7V
Input Voltage (Pins 2, 3, 5, 8, 12, 13; See Note 1)	5.5V
Decimal Point Current	20 mA
Operating Ambient-Air Temperature Range	0°C to 70°C
Storage Temperature Range	-55°C to 100°C

NOTE 1: Voltage values are with respect to common ground terminal.

recommended operating conditions

	MIN	NOM	MAX	UNIT
Logic Supply Voltage, V_{CC}	4.5	5	6.5	V
LED Supply Voltage, V_{LED}	4	5	7	V
Decimal Point Current, $I_{F(DP)}$		5		mA
Latch Strobe Pulse Width, t_w	40			ns
Setup Time, t_{setup} (See Note 2)	50			ns
Hold Time, t_{hold} (See Note 3)	40			ns

- NOTES: 2. Setup time is the interval immediately preceding the positive going transition of the latch strobe input during which interval the data to be displayed must be maintained at the latch data inputs to ensure its recognition.
 3. Hold time is the interval immediately following the positive-going transition of the latch strobe input during which interval the data to be displayed must be maintained at the latch data inputs to ensure its continued recognition.

operating characteristics at 25°C ambient-air temperature

PARAMETER		TEST CONDITIONS	MIN	TYP	MAX	UNIT	
I_V	Luminous Intensity (See Note 4)	Average Per Character LED	$V_{CC} = 5V,$	$V_{LED} = 5V$	20	50	μcd
		Each decimal	$I_F(DP) = 5 mA$		20	50	μcd
λ_p	Wavelength at Peak Emission	$V_{CC} = 5V,$	$V_{LED} = 5V$	640	660	680	nm
B	Spectral Bandwidth between Half-Power Points	$I_F(DP) = 5 mA,$ See Note 6		20		nm	
V_{IH}	High-Level Input Voltage			2		V	
V_{IL}	Low-Level Input Voltage			0.8		V	
V_I	Input Clamp Voltage	$V_{CC} = 4.75V,$ $I_I = -12 mA$		-1.5		V	
I_I	Input Current at Maximum Input Voltage	$V_{CC} = 5.5V,$ $V_I = 5.5V$		1		mA	
I_{IH}	High-Level Input Current	$V_{CC} = 5.5V,$ $V_I = 2.4V$		40		μA	
I_{IL}	Low-Level Input Current	$V_{CC} = 5.5V,$ $V_I = 0.4V$		-1.6		mA	
I_{CC}	Logic Supply Current	$V_{CC} = 5.5V,$ $V_{LED} = 5.5V,$		60	90	mA	
I_{LED}	LED Supply Current	$I_F(DP) = 5 mA,$ All inputs at OV		45	90	mA	

- NOTES:** 4. Luminous intensity is measured with a solar cell and filter combination which approximates the CIE (International Commission on Illumination) eye-response curve.
 5. This parameter is measured with displayed, then again with displayed.
 6. These parameters are measured with displayed.

TYPICAL CHARACTERISTICS

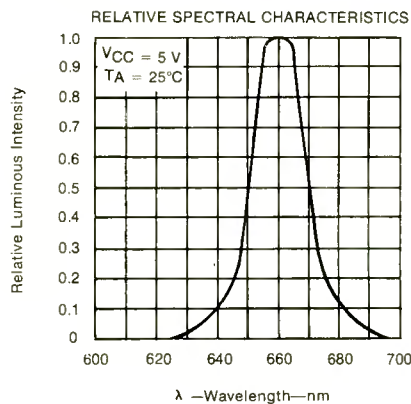

FIGURE 1

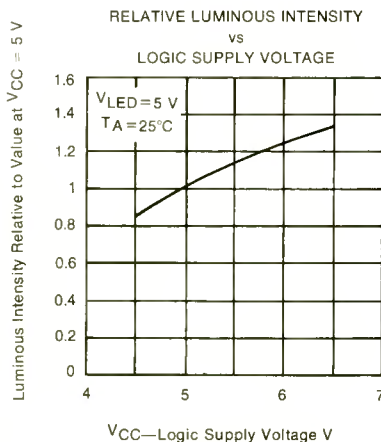

FIGURE 2

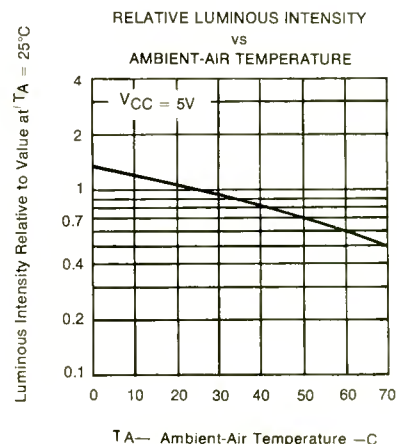
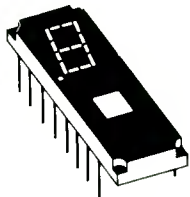

FIGURE 3



745-0008 Solid State LED

DIAL-LITE® Numeric Display

With Integral TTL MSI Circuit Chip

Character Height: .270"

The display and TTL MSI chip are mounted on a substrate and the assembly is then cast within a clear electrically nonconductive transparent plastic compound.

**Solid-State Visible Displays With
Integral TTL MSI Circuit Chip
For Use In All Systems Requiring
A Display Of BCD Data**

features

- 0.270-Inch-High Character
- High Brightness
- Has Left Hand Decimal Point
- Easy System Interface
- Single-Plane Wide-Angle Visibility
- Internal TTL MSI Chip with Latch, Decoder, and Driver
- Constant-Current Drive for Light-Emitting Diodes

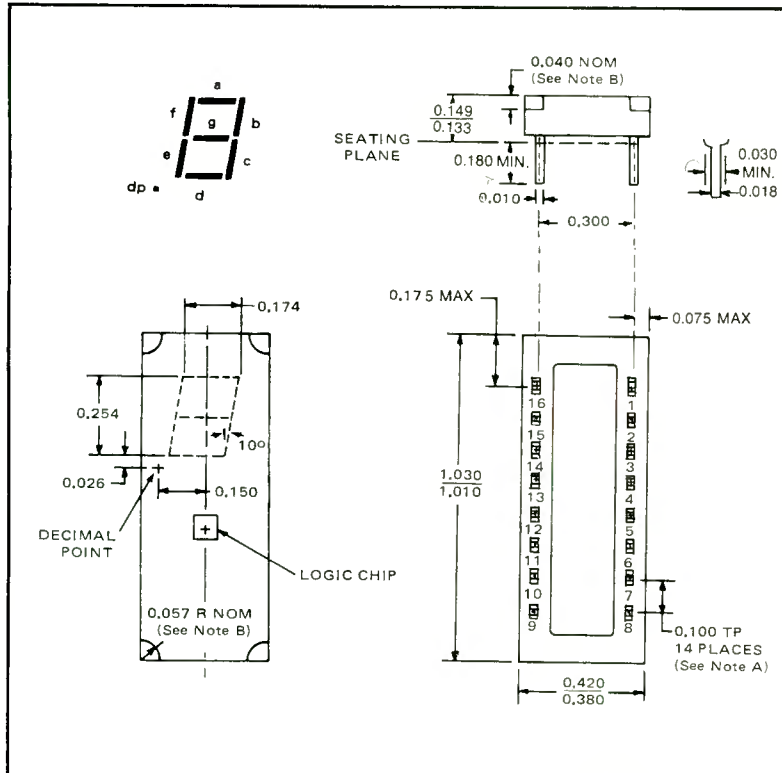

**PIN ASSIGNMENTS
FOR BOTH TYPES**

NOTES:

- A. The true-position pin spacing is 0.100 between centerlines. Each pin centerline is located within 0.010 of its true longitudinal position relative to pins 2 and 15.
- B. Nominal dimensions of all four corner notches are the same.
- C. Centerlines of character segments and decimal points are shown as dashed lines. Associated dimensions are nominal.
- D. Lead dimension is not controlled above the seating plane.
- E. All dimensions are in inches unless otherwise specified.

- PIN 1 LATCH OUTPUT QB (BINARY WEIGHT 2)
- PIN 2 LATCH OUTPUT QC (BINARY WEIGHT 4)
- PIN 3 LATCH OUTPUT QD (BINARY WEIGHT 8)
- PIN 4 LATCH OUTPUT QA (BINARY WEIGHT 1)
- PIN 5 LATCH STROBE INPUT
- PIN 6 LATCH DATA INPUT C (BINARY WEIGHT 4)
- PIN 7 LATCH DATA INPUT D (BINARY WEIGHT 8)
- PIN 8 GROUND
- PIN 9 NO INTERNAL CONNECTION
- PIN 10 LATCH DATA INPUT B (BINARY WEIGHT 2)
- PIN 11 BLANKING INPUT
- PIN 12 LATCH DATA INPUT DP
- PIN 13 LED TEST
- PIN 14 LATCH OUTPUT DP
- PIN 15 LATCH DATA INPUT A (BINARY WEIGHT 1)
- PIN 16 SUPPLY VOLTAGE, VCC

Socket 501-0702-009

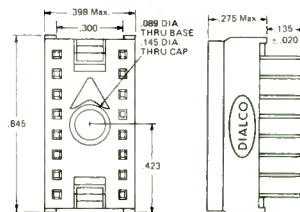

for use with 745-0008 display

description 745-0008

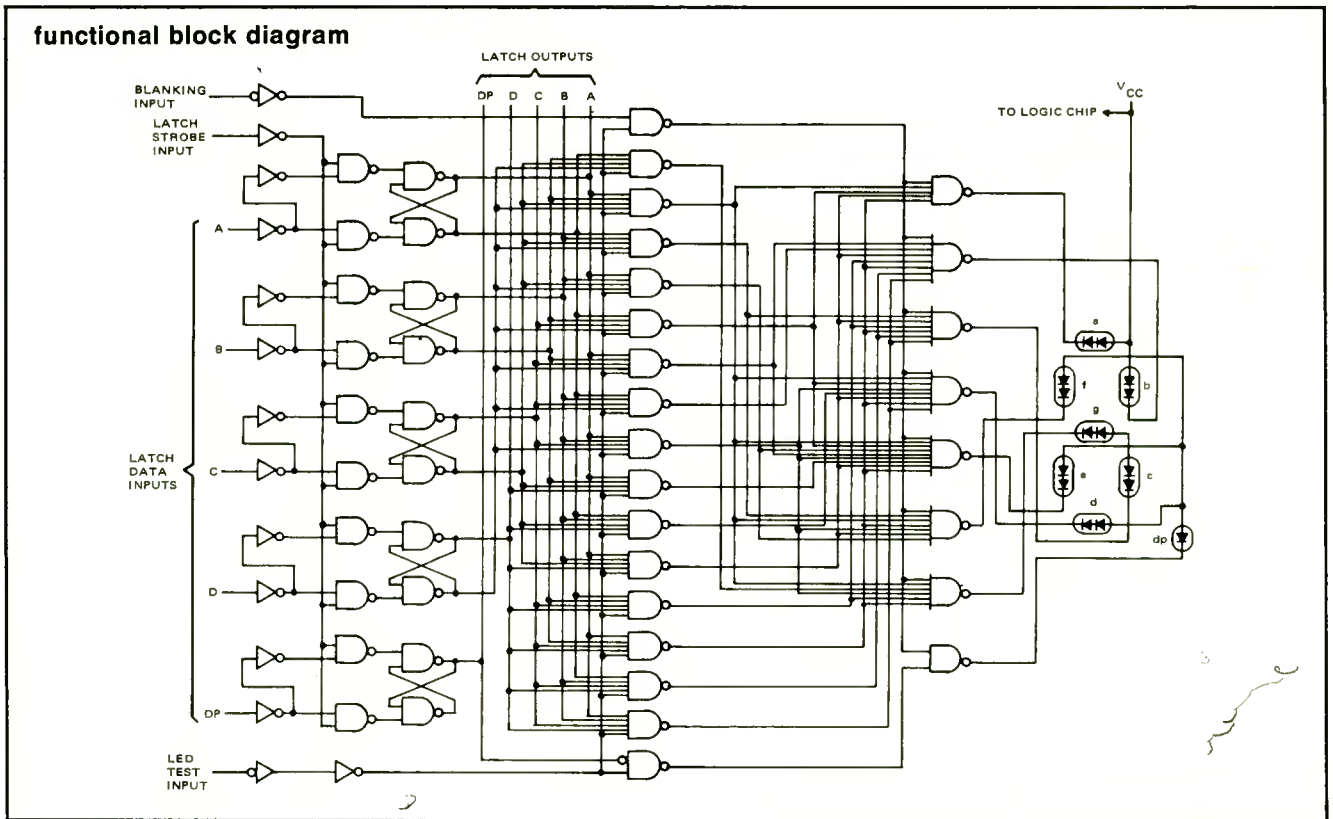

These internally-driven seven-segment light-emitting-diode (LED) displays contain a five-bit latch and a decoder/LED driver in a single 16-pin package. A description of the functions of the inputs and outputs of these devices follows:

FUNCTION	PIN NO.	DESCRIPTION
LATCH STROBE INPUT	5	When low, the data in the latches follow the data on the latch inputs. When high, the data in the latches are held constant and are unaffected by new data on the latch inputs.
LATCH DATA INPUTS A, B, C, D, DP	15, 10, 6, 7, 12	Data on these inputs are entered into the latches under the control of the latch strobe input. The binary weights of the inputs are: A = 1, B = 2, C = 4, D = 8. DP is decimal point latch data input.
LATCH OUTPUTS QA, QB, QC, QD, QDP	4, 1, 2, 3, 14	The BCD data that drives the decoder is stored in the five latches and is available at these outputs. The binary weights of the outputs are: QA = 1, QB = 2, QC = 4, QD = 8. QDP is decimal point latch output.
BLANKING INPUT BI	11	When low, will blank (turn off) the entire display. Must be high for normal operation of the display.
LED TEST INPUT	13	When low, will turn on the entire display, overriding the data in the latches and the blanking input. Must be high for normal operation of the display.

function table

FUNCTION	LATCH INPUTS					BLANKING INPUT	LED TEST	LATCH OUTPUTS					DISPLAY	
	D	C	B	A	DP			QD	QC	QB	QA	QDP		
0	L	L	L	L	L	H	H	L	L	L	L	L	L	0
1	L	L	L	H	H	L	H	L	L	L	H	H	H	. 1
2	L	L	H	L	L	L	H	L	L	H	L	L	L	2
3	L	L	H	H	H	L	H	L	L	H	H	H	H	. 3
4	L	H	L	L	L	L	H	L	H	L	L	L	L	4
5	L	H	L	H	H	L	H	L	H	L	H	H	H	. 5
6	L	H	H	L	L	L	H	L	H	H	L	L	L	6
7	L	H	H	H	H	L	H	L	H	H	H	H	H	. 7
8	H	L	L	L	L	L	H	H	L	L	L	L	L	8
9	H	L	L	H	H	L	H	H	L	L	H	H	H	. 9
A	H	L	H	L	L	L	H	H	L	H	L	L	L	A
MINUS SIGN	H	L	H	H	H	L	H	H	L	H	H	H	H	—
C	H	H	L	L	L	L	H	H	H	L	L	L	L	C
BLANK	H	H	L	H	H	L	H	H	H	L	H	H	H	.
E	H	H	H	L	L	L	H	H	H	H	L	L	L	E
F	H	H	H	H	H	L	H	H	H	H	H	H	H	. F
BLANK	X	X	X	X	X	X	L	H	X	X	X	X	X	.
LED TEST	X	X	X	X	X	X	X	L	X	X	X	X	X	. 8

H = high level, L = low level, X = irrelevant.
DP input has arbitrarily been shown activated (high) on every other line of the table.

description 745-0008

The TTL MSI circuits contain the equivalent of 78 gates on a single chip. Logic inputs and outputs are completely TTL/DTL compatible. The buffered inputs are implemented with relatively large resistors in series with the bases of the input transistors to lower drive-current requirements to one-half of that required for a standard Series 54/74 TTL input.

Some of the additional features of these displays are as follows:

- Latched BCD and decimal point logic outputs are provided to drive logic processors simultaneously with the displayed data
- Minimum number of inputs required . . . 4-line BCD plus decimal point
- Overriding blanking for suppressing entire display or for pulse-modulation of LED brightness
- LED test input simultaneously turns on all display segments and decimal point
- Can be operated in a real-time mode or latched-update-only mode by use of the latch strobe input
- Displays numbers 0 thru 9 as well as A, C, E, F, or minus sign
- Can be blanked by entry of BCD 13 or by use of the blanking input
- Decimal point controlled independently with decimal-point latch
- Constant-current-source TTL-LED interface for optimum performance.

The latch outputs except Q_{DP}, are active pull up, and each one including Q_{DP} is capable of driving three standard Series 54/74 loads. The LED driver outputs are designed specifically to maintain a relatively constant on-level current of approximately 15 milliamperes through LED segments "a" through "g" and seven milliamperes through the decimal point LED. All inputs are diode-clamped to minimize transmission-line effects, thereby simplifying system design. Power dissipation is typically 750 milliwatts with all segments on.

absolute maximum ratings over operating ambient-air temperature range (unless otherwise noted)

Supply Voltage, V _{CC} (See Note 1): Continuous	5.5 V
Nonrepetitive Peak, t _w ≤ 100 ms	7V
Input Voltage (See Note 1)	5.5 V
Operating Ambient-Air Temperature Range	0°C to 70°C
Storage Temperature Range	-55°C to 100°C

NOTE 1: Voltage values are with respect to network ground terminal.

recommended operating conditions

			MIN	NOM	MAX	UNIT
Supply Voltage, V _{CC}			4.75	5	5.25	v
Normalized Fan-out from Each output, N	Low Logic Level	Any Output			3	
	High Logic Level	Q _{DP}			3	
		Q _A , Q _B , Q _C , Q _D			6	
Latch Strobe Pulse Width, t _w			30			ns
Setup Time, t _{setup} (See Note 2)			40			ns
Hold Time, t _{hold} (See Note 3)			0			ns

NOTES: 2. Setup time is the interval immediately preceding the positive-going transition of the latch strobe during which interval the data to be latched must be maintained at the latch inputs to ensure its recognition.

3. Hold time is the interval immediately following the positive-going transition of the latch strobe during which interval the data to be latched must be maintained at the latch inputs to ensure its continued recognition.

DIODE-LITE[®] 745-0008

solid state LED READOUT
character height: .270"

operating characteristics at 25°C ambient-air temperature

	PARAMETER	TEST CONDITIONS	MIN	TYPE	MAX	UNIT	
B	Luminance (Photometric Brightness, See Note 4 and 5)	V _{CC} = 5 V, See Note 6	200	350		fL	
λ _{peak}	Wavelength at Peak Emission	V _{CC} = 5 V, See Note 6	6300	6500	6700	Å	
BW _λ	Spectral Bandwidth between Half-Power Points	V _{CC} = 5 V, See Note 6		200		Å	
V _{IH}	High-Level Input Voltage		2			V	
V _{IL}	Low-Level Input Voltage				0.8	V	
V _I	Input Clamp Voltage	V _{CC} = 4.75 V, I _I = -12 mA			-1.5	V	
V _{OH}	High-Level Output Voltage	Q _{DP}	V _{CC} = 4.75 V, I _{OH} = -120 nA	2.4		V	
		Q _A , Q _B , Q _C , Q _D	V _{CC} = 4.75 V, I _{OH} = -240 nA				
V _{OL}	Low-Level Output Voltage	V _{CC} = 4.75 V, I _{OL} = 4.8 mA			0.4	V	
I _I	Input Current at Maximum Input Voltage	V _{CC} = 5.25 V, V _I = 5.5 V			1	mA	
I _{IH}	High-Level Input Current	V _{CC} = 5.25 V, V _I = 2.4 V			20	μA	
I _{IL}	Low-Level Input Current	V _{CC} = 5.25 V, V _I = 0.4 V			-0.8	mA	
I _{OS}	Short-Circuit Output Current	Q _A , Q _B , Q _C , Q _D	V _{CC} = 5.25 V,		-9	-27.5	mA _I
		Q _{DP}			-1	-2.4	
I _{CC}	Supply Current	V _{CC} = 5.25 V, All inputs at 0 V		150	230	mA	

‡ All typical values are at V_{CC} = 5 V.

- NOTES:** 4. Luminance may also be measured in candelas per square foot (cd/ft²) or candelas per square meter (cd/m²). To convert foot-lamberts to these units use the following equivalencies: 1 fL = (1/π) cd/ft² = 3.4263 cd/m².
5. Luminance is measured with a Photo Research Brightness Spot Meter (or equivalent).
6. These parameters are measured with all LED segments and the decimal point on.

TYPICAL CHARACTERISTICS

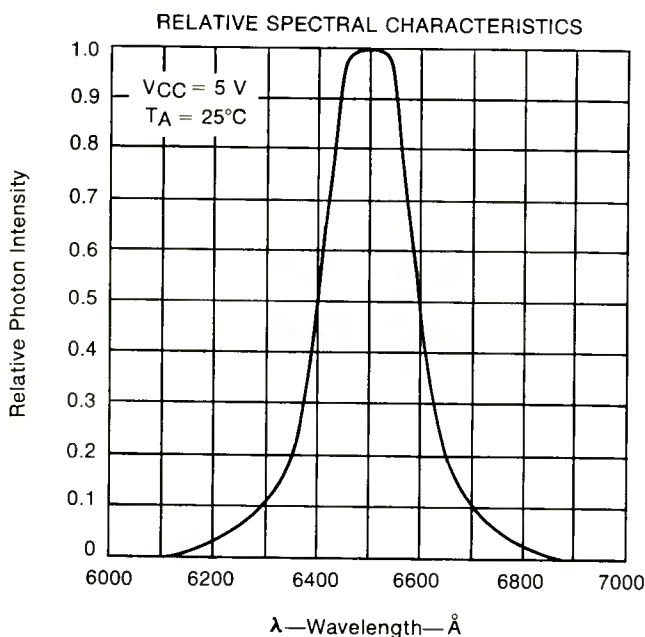

FIGURE 1

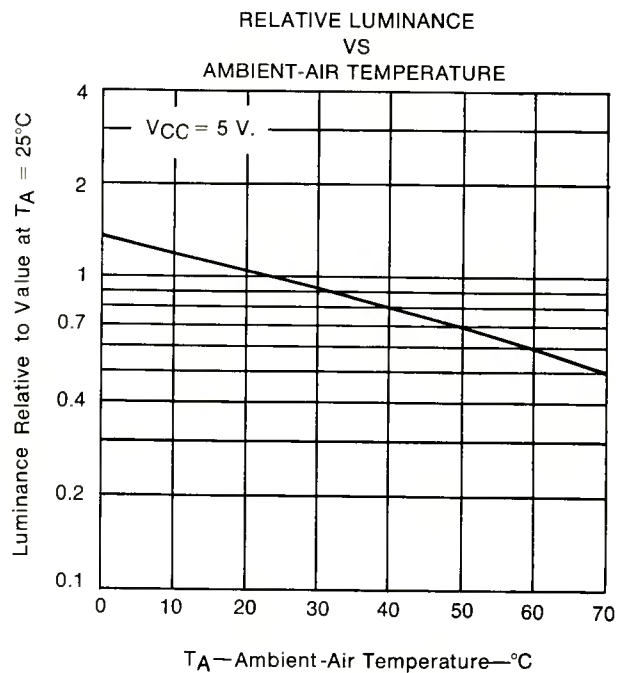
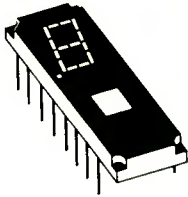

FIGURE 2

745-0009 solid state LED

DIAL-LITE® Numeric Display with Integral TTL MSI Circuit Chip with Counter character height: .270"



The display and TTL MSI chip are mounted on a substrate and the assembly is then cast within a clear electrically nonconductive transparent plastic compound.

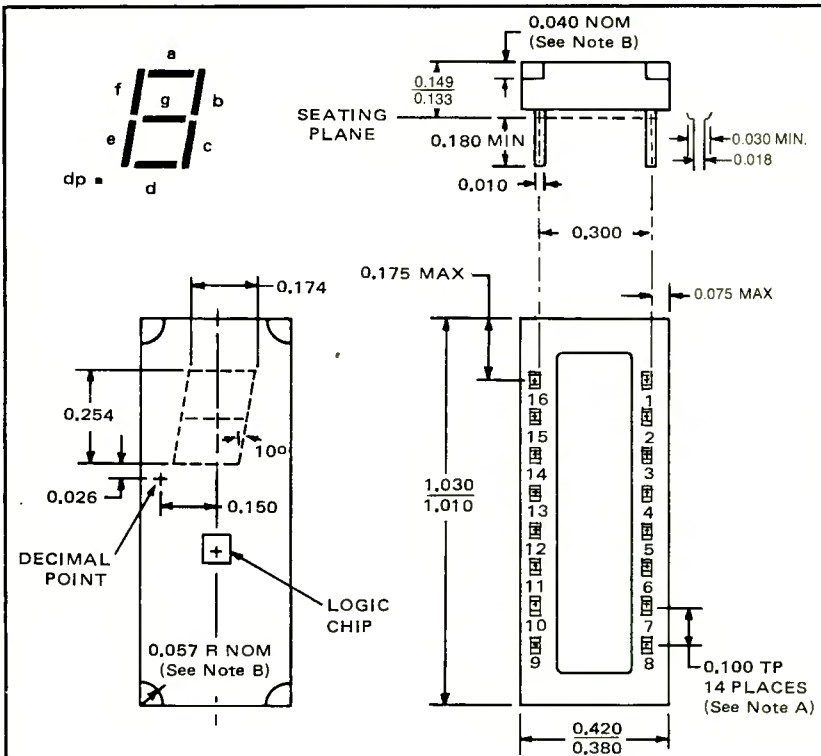

PIN ASSIGNMENTS

- PIN 1 LATCH OUTPUT QB (BINARY WEIGHT 2)
- PIN 2 LATCH OUTPUT QC (BINARY WEIGHT 4)
- PIN 3 LATCH OUTPUT QD (BINARY WEIGHT 8)
- PIN 4 LATCH OUTPUT QA (BINARY WEIGHT 1)
- PIN 5 LATCH STROBE
- PIN 6 RIPPLE-BLANKING INPUT
- PIN 7 MAXIMUM-COUNT OUTPUT
- PIN 8 GROUND
- PIN 9 PARALLEL CARRY
- PIN 10 SERIAL CARRY
- PIN 11 RIPPLE-BLANKING OUTPUT NODE
- PIN 12 CLEAR
- PIN 13 DECIMAL POINT INPUT
- PIN 14 BLANKING INPUT
- PIN 15 CLOCK
- PIN 16 SUPPLY VOLTAGE, V_{CC}

NOTES:

- A. The true-position pin spacing is 0.100 between centerlines. Each pin centerline is located within 0.010 of its true longitudinal position relative to pins 2 and 15.
- B. Nominal dimensions of all four corner notches are the same.
- C. Centerlines of character segments and decimal points are shown as dashed lines. Associated dimensions are nominal.
- D. Lead dimension is not controlled above the seating plane.
- E. All dimensions are in inches unless otherwise specified.

Solid-State visible displays with integral TTL MSI circuit chip with counter for use in all systems where the data to be displayed is the pulse count.

features

- 0.270 Inch High Character
- High Brightness
- Has Left Hand Decimal Point
- Easy System Interface
- Single-Plane Wide-Angle Visibility
- Integral TTL MSI Chip with Counter, Latch, Decoder, and Driver
- Constant-Current Drive for Light-Emitting Diodes

Socket 501-0702-009

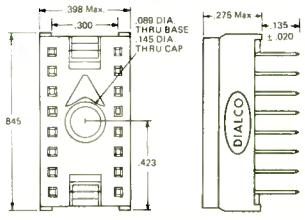

for use with 745-0009 display

description 745-0009

These internally-driven seven-segment light-emitting-diode (LED) displays contain a BCD counter, a four-bit latch, and a decoder/LED driver in a single 16-pin package. A description of the functions of the inputs and outputs of these devices follows:

FUNCTION	PIN NO.	DESCRIPTION
CLEAR INPUT	12	When low, resets and holds counter at 0. Must be high for normal counting.
CLOCK INPUT	15	Each positive-going transition will increment the counter provided that the circuit is in the normal counting mode (serial and parallel carry inputs low, clear input high).
PARALLEL CARRY INPUT	9	Must be low for normal counting mode. When high, counter will be inhibited. Logic level must not be changed when the clock is low.
SERIAL CARRY INPUT	10	Must be low for normal counting mode, also must be low to enable maximum count output to go low. When high, counter will be inhibited and maximum count output will be driven high. Logic level must not be changed when the clock is low.
MAXIMUM COUNT OUTPUT	7	Will go low when the counter is at 9 and serial carry input is low. It will return high when either serial input goes high or counter changes to 0.
LATCH STROBE	5	When low, data in latches follow the data in the counter. When high, the data in the latches are held constant, and the counter may be operated independently.
LATCH OUTPUTS QA, QB, QC, QD	4,1,2,3	The BCD data that drives the decoder is stored in the 4-bit latch and is available at these outputs. The binary weights of the outputs are: QA=1, QB=2, QC=4, QD=8.
DECIMAL POINT INPUT	13	Must be high to display decimal point. The decimal point is not displayed when this input is low or when the display is blanked.
BLANKING INPUT BI	14	When high, will blank (turn off) the entire display and force RBO low. Must be low for normal counting.
RIPPLE-BLANKING INPUT RBI	6	When the data in the latches is BCD 0, a low input will blank the entire display and force the RBO low. This input has no effect if the data in the latches is other than 0.
RIPPLE-BLANKING OUTPUT NODE	11	Supplies ripple blanking information for the ripple blanking input of the next decade. Provides a low if BI is high, or if RBI is low and the data in the latches is BCD 0. This pin has a resistive pull-in circuit suitable for performing a wire-AND function with any open-collector output. Whenever this pin is low the entire display will be blanked; therefore, this pin may be used as an active-low blanking input.

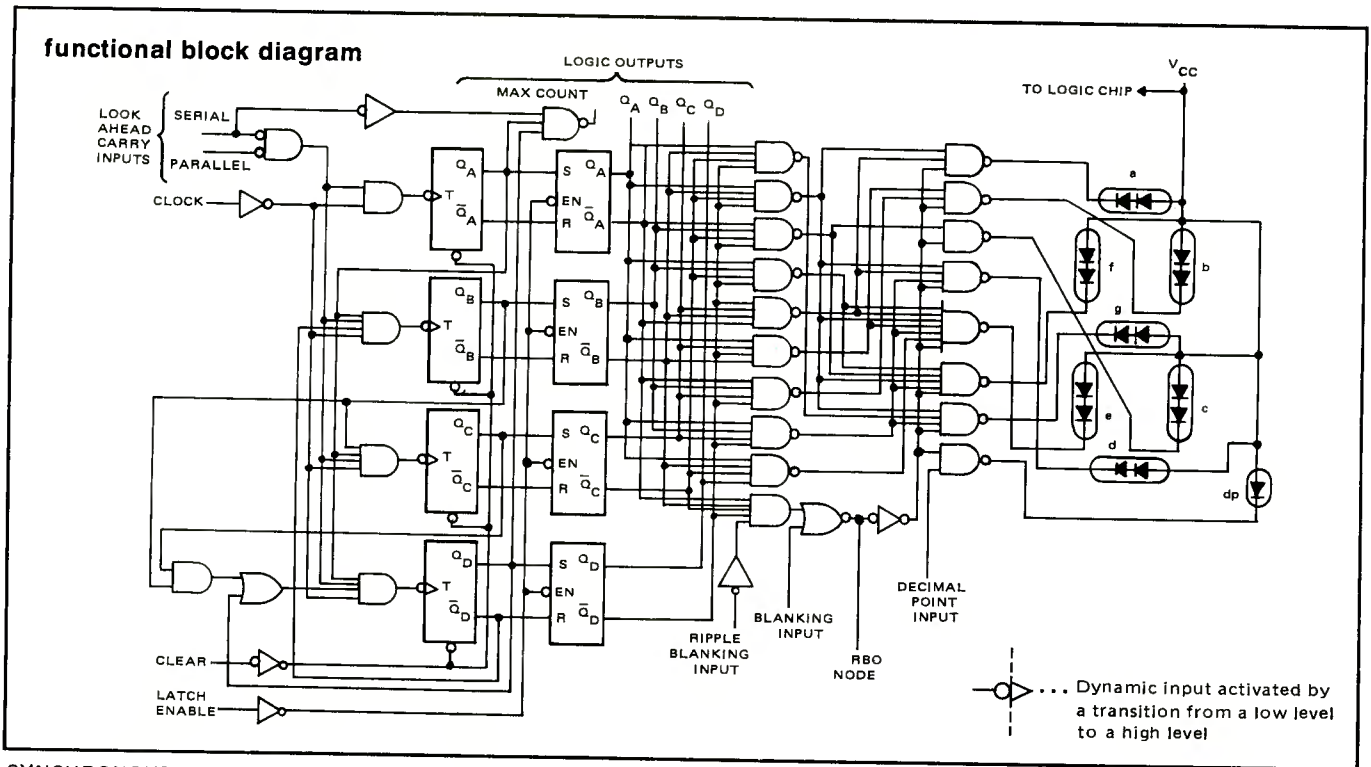

SYNCHRONOUS BCD COUNTER, 4-BIT LATCH, DECODER/DRIVER, SEVEN-SEGMENT LED DISPLAY WITH DECIMAL POINT

description 745-0009

The TTL MSI circuits contain the equivalent of 86 gates on a single chip. Logic inputs and outputs are completely TTL/DTL compatible. The buffered inputs are implemented with relatively large resistors in series with the bases of the input transistors to lower drive-current requirements to one-half of that required for a standard Series 54/74 TTL input. The serial-carry inputs, actually two internal loads, is rated as one standard series 54/74 load.

The logic outputs, except the RBO node, are active pull-up, and the latch outputs QA, QB, QC and QD are each capable of driving three standard Series 54/74 loads at a low logic level or six loads at a high level while the maximum-count output is capable of driving seven 54/74 loads at a low logic level or 14 loads at a high logic level. The RBI/RBO node serves as a blanking input with wire-AND connection and a passive pull-up, or as a ripple-blanking output supplying the ripple-blanking input information for the next decade.

The LED driver outputs are designed specifically to maintain a relatively constant on-level current of approximately 15 milliamperes through LED segments "a" through "g" and seven milliamperes through the decimal point LED. All inputs are diode-clamped to minimize transmission-line effects, thereby simplifying system design. Maximum clock frequency is typically 18 megahertz and power dissipation is typically 825 milliwatts with all segments on.

These displays may be interconnected to produce an n-digit with the following features:

- Ripple-blanking input and output for suppressing extraneous less-significant digits (LSD) or more-significant digits (MSD).
- Comprehends floating-decimal-point logic
- Overriding blanking for suppressing entire display or pulse-modulation of LED brightness
- Dual count-enable inputs provide for parallel look-ahead and serial ripple logic to build high-speed fully synchronous, multidigit counter systems with no external logic, minimizing total propagation delay from the clock to the last latch output.
- Provision for ripple-count cascading between packages
- Positive-edge-triggered synchronous BCD counter
- Parallel BCD data outputs from latch drive logic processors simultaneously with the displayed data
- Latch strobe allows counter to operate while a previous data point is displayed
- Reset-to-zero capability with clear input

absolute maximum ratings over operating ambient-air temperature range (unless otherwise noted)

Supply Voltage, V_{CC} (See Note 1): Continuous	5.5 V
Nonrepetitive Peak, $t_w \leq 100$ ms	7 V
Input Voltage (See Note 1)	5.5 V
Operating Ambient-Air Temperature Range	0° C to 70° C
Storage Temperature Range	-55° C to 100° C

NOTE 1: Voltage values are with respect to network ground terminal.

recommended operating conditions

	MIN	NOM	MAX	UNIT
Supply Voltage, V_{CC}	4.75	5	5.25	V
Low-Level Output Current, I_{OL}	$Q_A, Q_B, Q_C, Q_D, RBI/RBO$		4.8	mA
	Maximum Count		11.2	
	RBO		-120	μ A
High-Level Output Current, I_{OH}	Q_A, Q_B, Q_C, Q_D		-240	
	Maximum Count		-560	
Clock Pulse Width, t_w (clock)	High Logic Level		25	ns
	Low Logic Level		55	
Clear Pulse Width, t_w (clear)			25	ns
Setup Time, t_{setup} (See Note 2)	Serial Carry and Parallel Carry		30	ns
	Clear Inactive State		30	

NOTE 2: Setup time is the interval immediately preceding the positive-going edge of the clock pulse during which interval the data to be recognized must be maintained at the input to ensure its recognition.

Operating characteristics at 25° C ambient-air temperature

PARAMETER	TEST CONDITIONS	MIN	TYPE ‡	MAX	UNIT
B Luminance (Photometric Brightness, Notes 3, 4)	$V_{CC} = 5$ V, See Note 5	200	350		fL
λ_{peak} Wavelength at Peak Emission	$V_{CC} = 5$ V, See Note 5	6300	6500	6700	Å
BW_λ Spectral Bandwidth between Half-Power Points	$V_{CC} = 5$ V, See Note 5		200		Å
V_{IH} High-Level Input Voltage		2			V
V_{IL} Low-Level Input Voltage				0.8	V
V_I Input Clamp Voltage	$V_{CC} = 4.75$ V, $I_I = -12$ mA			-1.5	V
V_{OH} High-Level Output Voltage	$V_{CC} = 4.75$ V, $I_{OH} = MAX^\dagger$	2.4			V
V_{OL} Low-Level Output Voltage	$V_{CC} = 4.75$ V, $I_{OL} = MAX^\dagger$			0.4	V
I_I Input Current at Maximum Input Voltage	$V_{CC} = 5.25$ V, $V_I = 5.5$ V			1	mA
I_{IH} High-Level Input Current	Serial Carry			40	μ A
	RBO Node	$V_{CC} = 5.25$ V, $V_I = 2.4$ V		-0.5	mA
	Other Inputs			20	μ A
I_{IL} Low-Level Input Current	Serial Carry			-1.6	mA
	RBO Node	$V_{CC} = 5.25$ V, $V_I = 0.4$ V		-2.4	
	Other Inputs			-0.8	
I_{OS} Short-Circuit Output Current	Q_A, Q_B, Q_C, Q_D	$V_{CC} = 5.25$ V		-9	mA
	Maximum Count			-55	
I_{CC} Supply Current	$V_{CC} = 5.25$ V, See Note 5		165	250	mA

† These parameters are tested using the appropriate value specified under recommended operating conditions for the applicable output.

‡ All typical values are at $V_{CC} = 5$ V.

NOTES: 3. Luminance may also be measured in candelas per square foot (cd/ft²) or candelas per square meter (cd/m²). To convert foot-lamberts to these units use the following equivalencies: 1 fL = (1/π) cd/ft² = 3.4263 cd/m².

4. Luminance is measured with a Photo Research Brightness Spot Meter (or equivalent).

5. These parameters are measured with all LED segments and the decimal point on.

DIODE-LITE® 745-0009

solid state LED READOUT

character height: .270"

switching characteristics, $V_{CC} = 5\text{ V}$, $T_A = 25^\circ\text{ C}$

PARAMETER §	FROM (INPUT)	TO (OUTPUT)	TEST CONDITIONS	MIN	TYP	MAX	UNIT
f_{max}				12	18		MHz
t_{PLH}	Serial Look-Ahead	Maximum Count	$C_L = 15\text{ pF}$, $R_L = 1.2\text{ K}\Omega$, See Figure 1		12	20	ns
t_{PHL}					23	35	
t_{PLH}	Clock	Maximum Count	See Figure 1		26	40	ns
t_{PHL}					29	45	
t_{PLH}	Clock	Q_A, Q_B, Q_C, Q_D	$C_L = 15\text{ pF}$, $R_L = 560\ \Omega$, See Figure 1		28	45	ns
t_{PHL}					38	60	
t_{PHL}	Clear	Q_A, Q_B, Q_C, Q_D			57	90	ns

t_{PLH} = Propagation delay time, low-to-high-level output
 t_{PHL} = Propagation delay time, high-to-low-level output

§ f_{max} = Maximum clock frequency

LOAD CIRCUIT-FIGURE 1

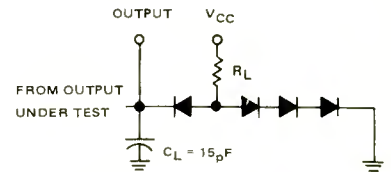

NOTES: A. C_L includes probe and jig capacitance.
 B. All diodes are 1N3064.

TYPICAL CHARACTERISTICS

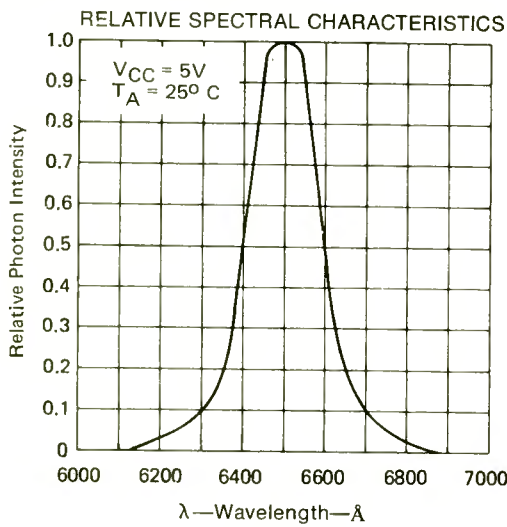

FIGURE 2

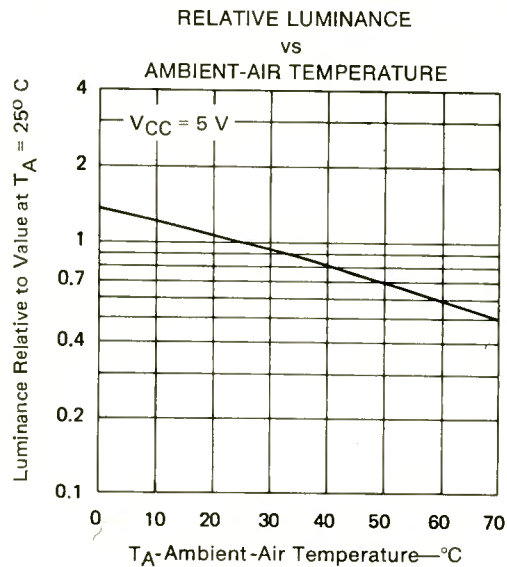
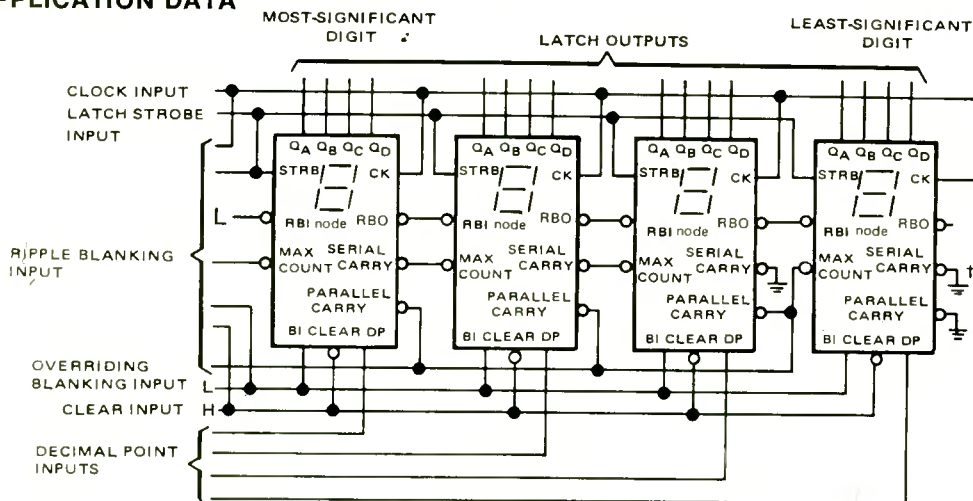

FIGURE 3

TYPICAL APPLICATION DATA



† The serial-carry input of the least-significant digit is normally grounded; it may be used as a count-enable control for the entire counter (high to disable, low to count) provided the logic level on this pin is not changed while the clock line is low or false counting may result.

This application demonstrates how the displays may be cascaded for N-bit display applications. It features:

- Synchronous, look-ahead counting
- Ripple blanking for leading- or trailing-edge zeros
- Overriding blanking for total suppression or intensity modulation of display
- Direct parallel clear
- Latch strobe permits counter to acquire data for the next display while viewing current display.

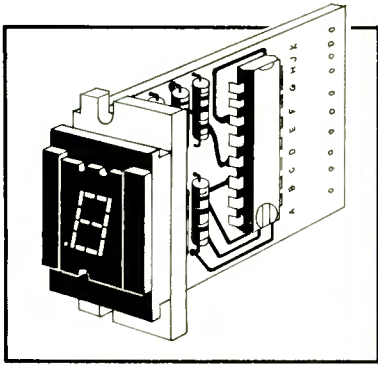

740-0005 & 740-0007

DIALIGHT®

Solid State LED Readout

character height: .270"

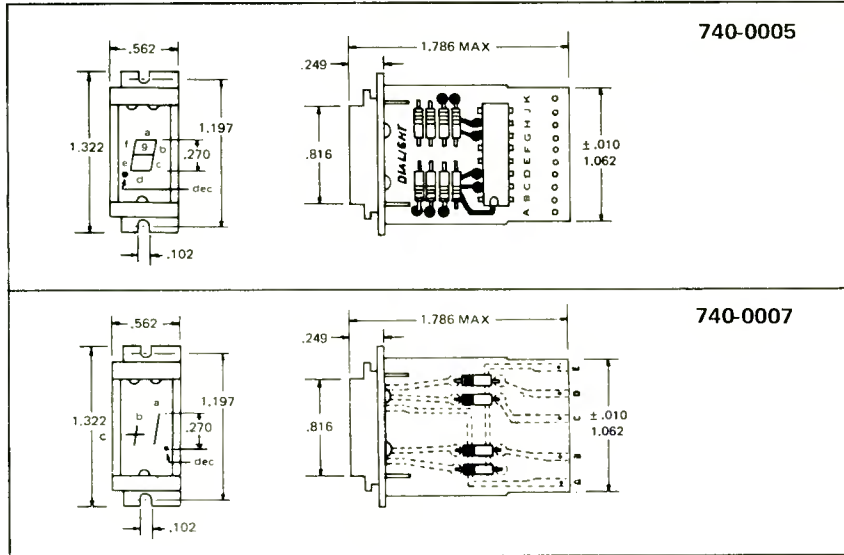

Features

- GaAsP LED
- .270" character size with decimal
- Complete with decoder/driver and necessary resistors
- Solid state reliability with life measured in years
- Immune to shock and vibration
- High brightness
- Single plane, wide angle visibility
- Polarity-overflow module
- Compatible with standard IC power supply levels

General Information

The Dialight 740 series LED display module consists of a Diode-Lite readout mounted on a PC board, complete with decoder/drivers and necessary current limiting resistors. The display is in a 7-segment format, featuring a bright red, highly legible character which is virtually immune to shock and vibration.

The decoder/driver requires 4 lines or bits of information in an 8421 BCD code. Terminals are provided on the PC board to allow automatic blanking of leading and/or trailing edge zeros, and for a lamp test which overrides the BCD inputs to check for a possible display malfunction.

The PC board offers the user an option of using an edge card connector (Dialight Part No. 501-0700-005), or hard wiring directly to the terminals.

The polarity overflow module has all necessary resistors on a PC board which is the same size as the standard display board for back of panel uniformity.

For the user desiring a complete bezel mounted assembly, please refer to 749-06XX data.

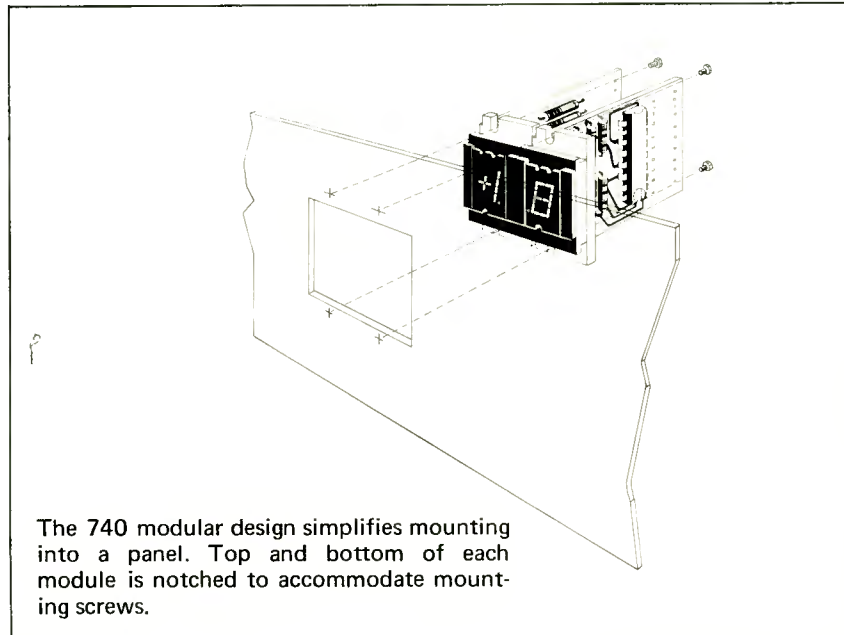

The 740 modular design simplifies mounting into a panel. Top and bottom of each module is notched to accommodate mounting screws.

Printed in U.S.A.
Copyright 1974 by Dialight, Brooklyn, N.Y. 11237

Dialight reserves the right to make changes at anytime in order to improve design and to supply the best product possible.



DIAL-LITE® Readout

character height: .270"

740-0005

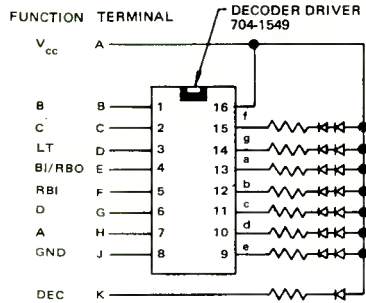

740-0007

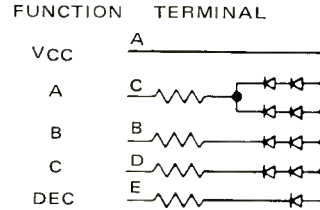

Operating Characteristics (Ambient Temperature 25° C)

Supply Voltage, V _{CC}	5 ± 0.25 V
Supply Current	190 mA All segments illuminated. 210 mA All segments and decimal point illuminated.
Logic '1' } BCD Inputs	2.0 to 5.5V
Logic '0' }	0.0 to 0.8V, sink 1.6 mA
Logic '1' } DEC	open
Logic '0' }	0.0 to 0.8 V, sink 20 mA
Temperature Range	0° to 70° C

Operating Characteristics (Ambient Temperature 25° C)

Supply Voltage, V _{CC}	5 ± 0.25 V
Supply Current	100 mA All segments and decimal point illuminated
Segment Current, a	40 mA
Segment Current, b & c	20 mA
Decimal Point Current	20 mA
Logic '1' } a, b, c	2.4 to 5.5 V or open
Logic '0' }	0.0 to 0.4 V
Logic '1' } DEC	4.0 to 5.5 V or open
Logic '0' }	0.0 to 0.8 V
Temperature Range	0° to 70° C

DECIMAL OR FUNCTION	INPUTS				* BI/RBO	RESULTANT DISPLAY
	LT	RBI	D	C B A		
0	1	1	0	0 0 0 0	1	0
1	1	X	0	0 0 0 1	1	1
2	1	X	0	0 0 1 0	1	2
3	1	X	0	0 0 1 1	1	3
4	1	X	0	1 0 0 0	1	4
5	1	X	0	1 0 0 1	1	5
6	1	X	0	1 1 0 0	1	6
7	1	X	0	1 1 1 1	1	7
8	1	X	1	0 0 0 0	1	8
9	1	X	1	0 0 1 1	1	9
BI	X	X	X	X X X X	0	
RBI	1	0	0	0 0 0 0	0	
LT	0	X	X	X X X X	1	8

'1' = HIGH LEVEL ■ BI/RBO IS WIRE-AND LOGIC
'0' = LOW LEVEL SERVING AS AN INPUT
'X' = ANY LEVEL AND/OR OUTPUT



Edge Card Connector 501-0700-005 – with flat solder terminals.
501-0700-009 – with PC terminals.
The printed circuit boards mate with Dialight's 501-0700-005 and 501-0700-009 edge card connectors. Holes are provided in each board for hard wiring as an alternative means of connection.

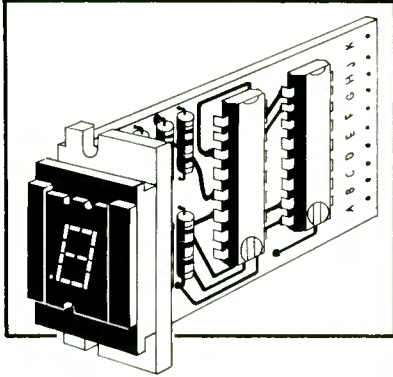

740-0011

DIODE-LITE® Readout
with Decoder/Driver & Latch
character height: .270"

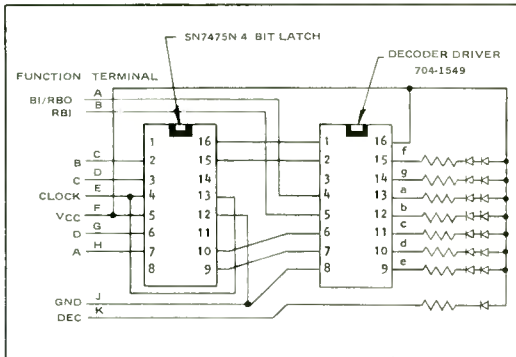
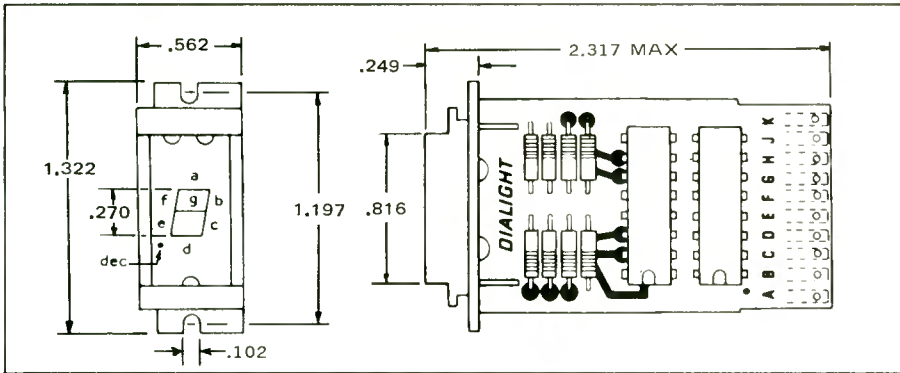

Edge Card Connector
501-0700-005, 501-0700-009

Operating Characteristics (Ambient Temperature 25° C)

Supply Voltage, V _{CC}	5 ± 0.25 V
Supply Current	225 mA All segments illuminated, 245 mA All segments and decimal point illuminated,
Logic '1'	2.0 to 5.5 V
Logic '0'	0.0 to 0.8 V, Sink 3.2 mA
Logic '1'	2.0 to 5.5 V
Logic '0'	0.0 to 0.8 V, Sink 12.8 mA
Logic '1'	Open
Logic '0'	0.0 to 0.8 V, Sink 20 mA
Temperature Range	0° to 70° C

Note: The BCD input data will be transferred and decoded when the clock is high. The resultant display will follow the BCD input data as long as the clock remains high.

Features

- .270" character with left hand decimal point
- GaAsP LED
- With decoder/driver and 4 bit latch
- Solid state reliability with life measured in years
- Single plane, wide angle visibility
- Virtually immune to shock and vibration
- Compatible with standard IC power supply levels

General Information

The Dialight 740 series LED display module consists of a Diode-Lite readout mounted on a PC board, complete with decoder/driver and 4 bit latch and all necessary current limiting resistors. The display features a bright red, highly legible character in a 7 segment format and is virtually immune to shock and vibration.

Four lines of information in an 8421 BCD code are required which will be transferred and decoded when the clock is high. The resultant display will follow the BCD input data as long as the clock remains high. Terminals are also provided on the PC board to allow automatic blanking of trailing and/or leading edge zeros.

Electrical connections to the PC board may be made by hard wiring, or by use of an edge card connector (Dialight # 501-0700-005).

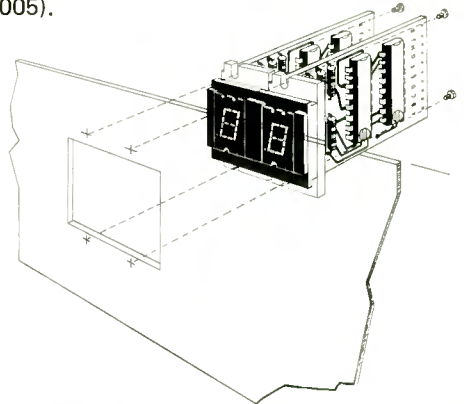

DECIMAL OR FUNCTION	INPUTS				BI/RBO	RESULTANT DISPLAY
	CLOCK	RBI	D C B A			
0	1	1	0 0 0 0	1	0	
1	1	X	0 0 0 1	1	1	
2	1	X	0 0 1 0	1	2	
3	1	X	0 0 1 1	1	3	
4	1	X	0 1 0 0	1	4	
5	1	X	0 1 0 1	1	5	
6	1	X	0 1 1 0	1	6	
7	1	X	0 1 1 1	1	7	
8	1	X	1 0 0 0	1	8	
9	1	X	1 0 0 1	1	9	
BI	X	X	X X X X	0		
RBI	1	0	0 0 0 0	0		

'1' = HIGH LEVEL, '0' = LOW LEVEL 'X' = ANY LEVEL
BI/RBO IS WIRE-AND LOGIC SERVING AS AN INPUT AND/OR OUTPUT

Printed in U.S.A.
Copyright 1974 by Dialight, Brooklyn, N.Y. 11237

Dialight reserves the right to make changes at anytime in order to improve design and to supply the best product possible.

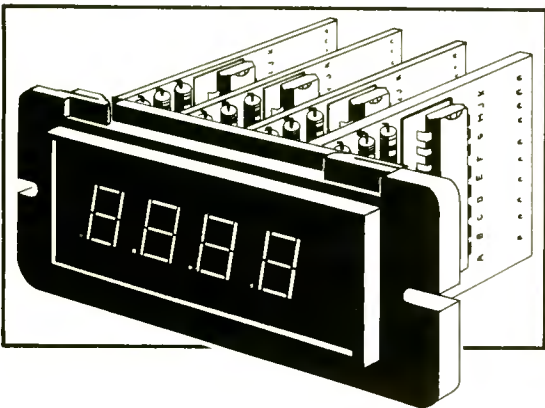

749 Series



Solid State LED Readout Assemblies
 character heights: .270" & .300"

Ordering Information

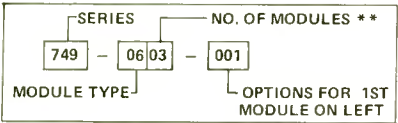

OPTIONS - LAST 3 DIGITS
 -001 = standard assembly with digits
 -002 = standard assembly with first module \pm
 -8XX = non-standard assembly

749 SERIES BEZEL DISPLAY ASSEMBLIES					INDIVIDUAL MOUNTING UNITS
Character Height	Description	Complete Assembly Series No.	Module Part No.	*Bezel No. for use with modules	Modified Modules for individual mounting
.270"	Display w/Decoder Driver	749-06XX	740-0006	743-100X	740-0005
.270"	Display	749-07XX	745-0006	743-200X	---
.270"	Display w/Decoder Driver and Latch	749-09XX	740-0012	743-100X	740-0011
.270"	Display w/Counter, Latch and Decoder Driver	749-14XX	740-0014	743-100X	740-0013
.270"	Hexadecimal Display w/Latch, Decoder Driver	749-12XX	745-0007	743-200X	---
.300"	Alphanumeric Display	749-08XX	745-0005	743-200X	---
.300"	Alphanumeric Display w/Character Generator	749-13XX	740-0019	743-100X	740-0018

*The last digit is determined by the number of digits in the assembly.
 **1st two digits in code block two denote module type.

Features

- GaAsP light source.
- Solid state reliability - Life measured in years
- Single plane, wide angle visibility
- Immune to shock and vibration
- Bezel assembly for ease of panel mounting
- Decimal point included
- Polarity-overflow module
- Options - BCD to 7 segment decoder/drivers, latch and counters. Character generator for alphanumeric.

General Description

The 749 series displays are supplied with a stylish black bezel for simplified panel mounting of multi-digit groupings. The displays feature a bright, highly legible character in a 7 segment format, .270" in height. The alphanumeric display is a 5x7 dot matrix, with a .300" high character. When supplied with decoder/drivers, latch and counters, all components are mounted on a PC board, with terminations provided for automatic blanking of leading and/or trailing edge zeros intensity control.

The user has the option of hard wiring to the board or using edge card connectors.

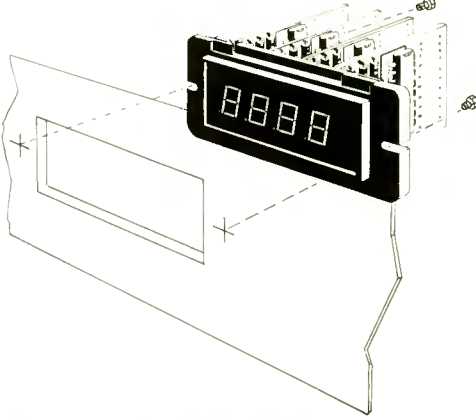
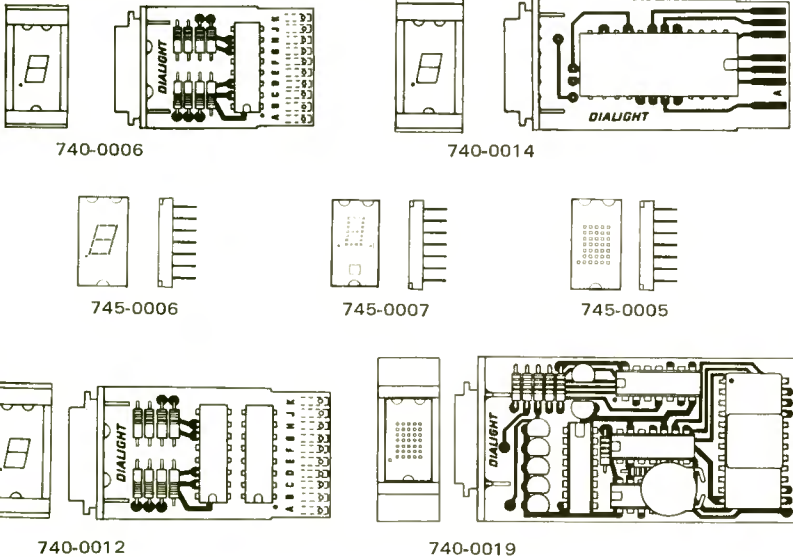

Printed in U.S.A.
 Copyright 1974 by Dialight, Brooklyn, N.Y. 11237

Dialight reserves the right to make changes at anytime in order to improve design and to supply the best product possible.



203 HARRISON PLACE • BROOKLYN, N.Y. 11237 • 212 497-7600 • TWX: 710-584-5487

Features and General Description



749-06XX, 749-07XX, 749-09XX, 749-14XX Series

.270" character height

Features

- GaAsP LED – high brightness
- Solid state reliability with life measured in years
- Single plane, wide angle visibility
- Bezel assembly for simplified panel mounting
- Left hand decimal point
- Complete with decoder/drivers
- Polarity-overflow module
- Immune to shock and vibration.

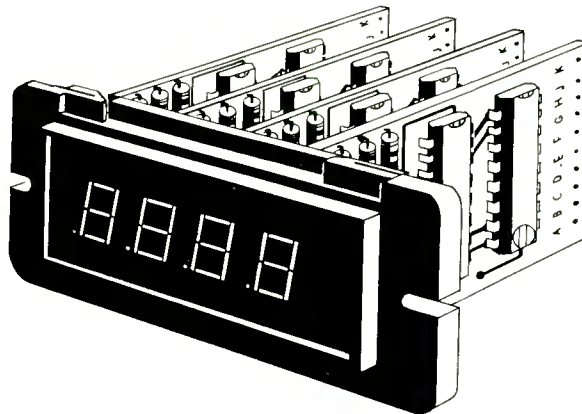

Typical 749-0904-001 Assembly

General Description

The **749-06XX** series features bright red characters, .270" in height, in a 7 segment format and supplied in a stylish black bezel for simplified panel mounting.

The decoder/drivers, one for each character, require 4 lines or bits of information in an 8421 BCD code. Terminals on the PC board are provided to allow automatic blanking of leading and/or trailing edge zeros and for a lamp test which overrides the BCD inputs to check for a possible display malfunction. The PC board of the polarity overflow module is the same length as the standard numeric module, for display uniformity.

The **749-09XX** series offers all of the above features less lamp test, but on a slightly longer board which includes an IC buffer storage unit with 4 gated latch circuits, and a common gate driver.

The BCD input data will be transferred when the clock is high. The resultant display will follow the BCD input data as long as the clock remains high.

Adding a decade counter to the display changes the part number to **749-14XX**. This allows the counting of input pulses and the display of these in decimal numbers, plus the memory of any count, so that the readout is

continuous when the counter is being updated.

The LED driver outputs are designed to maintain a relatively constant on-level current of approximately 15 mA through the LED segments and 7 mA through the decimal point. Inputs are diode-clamped to minimize transmission line effects, simplifying system design. Maximum clock frequency is typically 18 megahertz.

For those wishing to furnish their own electronics, the display is also supplied with the modules only in the same stylish black bezel. The series part number is **749-07XX**.

EDGE CARD CONNECTORS

501-0700-005
501-0700-009



Printed circuit board can be wired to directly or may be used with Dialight printed circuit edge type connector No. 501-0700-005 (solder type connections) or No.501-0700-009 (printed circuit or wire wrap terminations).

NOTE: For 749-14XX Series only, use Viking Industries series 2VH10/1J, Continental Connector series K600-121 or Mepco, Inc. series F-061 edge type connectors.

Dimensions



749-06XX, 749-07XX, 749-09XX, 749-14XX Series

.270" character height

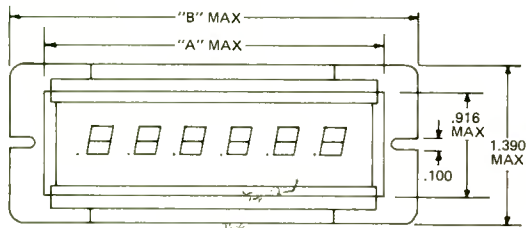

749-06XX-____, 749-09XX-____, 749-14XX-____

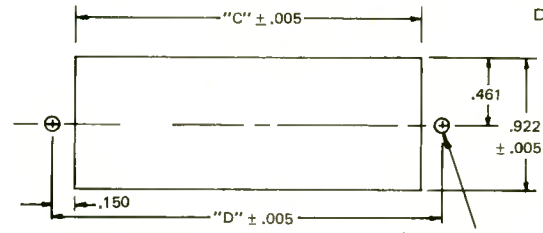

749-07XX-____

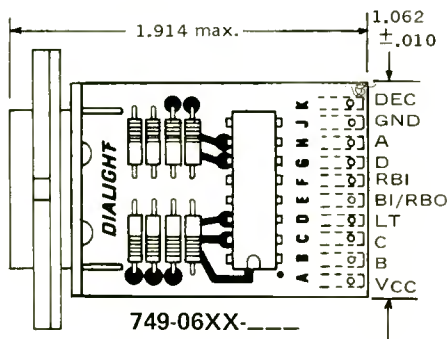

749-06XX-____

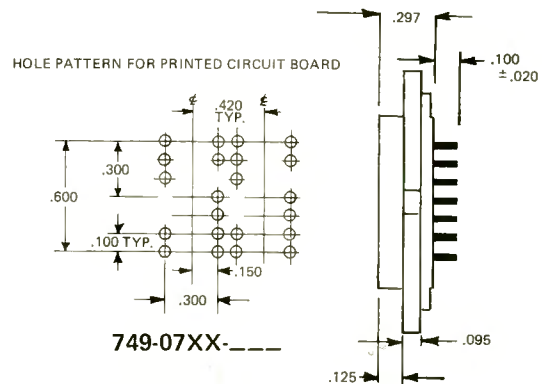

749-07XX-____

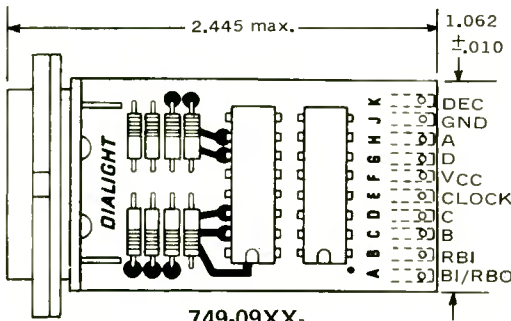

749-09XX-____

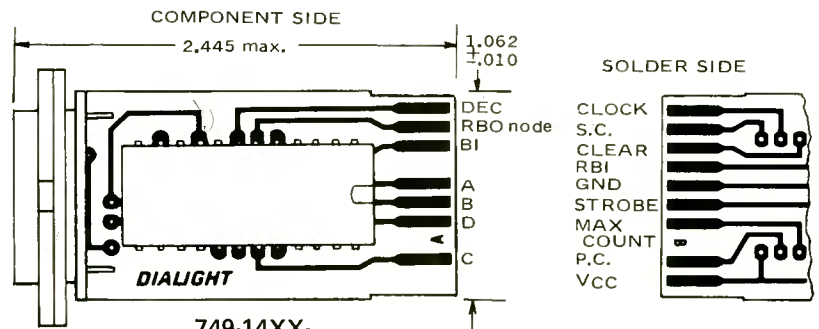

749-14XX-____

CATALOG NUMBER	* CHAR-ACTERS	DIMENSIONS †			
		A	B	C	D
749-0601	1	1.093	1.701	1.100	1.401
749-0602	2	1.656	2.264	1.663	1.964
749-0603	3	2.219	2.827	2.226	2.527
749-0604	4	2.780	3.388	2.787	3.088
749-0605	5	3.345	3.953	3.352	3.653
749-0606	6	3.908	4.516	3.915	4.216
749-0607	7	4.471	5.079	4.478	4.779
749-0608	8	5.034	5.642	5.041	5.342
749-0609	9	5.596	6.204	5.603	5.904
749-0610	10	6.160	6.768	6.167	6.468

CATALOG NUMBER	* CHAR-ACTERS	DIMENSIONS			
		A	B	C	D
749-0701	1	.951	1.559	.958	1.259
749-0702	2	1.372	1.980	1.379	1.680
749-0703	3	1.793	2.401	1.800	2.101
749-0704	4	2.214	2.822	2.221	2.522
749-0705	5	2.635	3.243	2.642	2.943
749-0706	6	3.056	3.664	3.063	3.364
749-0707	7	3.477	4.085	3.484	3.785
749-0708	8	3.898	4.506	3.905	4.206
749-0709	9	4.319	4.927	4.326	4.627
749-0710	10	4.740	5.348	4.747	5.048

† NOTE: Dimensions also apply to 749-09XX and 749-14XX

* For assemblies with more than 10 characters, consult factory.

Features and General Description



749-08XX and 749-13XX Series

5x7 dot matrix Alphanumeric Display

.300" character height

Features

- .300" high character
- Single plane wide angle visibility
- 5x7 matrix array, including decimal point
- Self contained character generator to display 64 ASCII characters
- Long life, shock and vibration resistant
- Bezel assemblies for simplified panel mounting

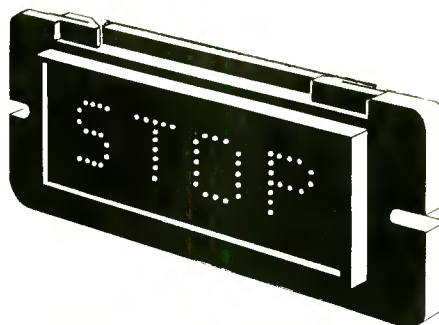

Typical 749-08XX-001 Assembly

The 749-13XX is a 5x7 dot matrix alpha-numeric display, complete with character generators to display 64 ASCII characters. The characters displayed are a function of 6 input lines, X1 through X6, as shown in the block diagram. The 7 rows of the display are scanned sequentially, one at a time. Timing is controlled by the clock which drives a binary counter whose outputs control the row to be selected. This insures that the character generators' 5 outputs, C1-C5, correspond to the row of dots which are enabled by the 1 out of 8 decoder.

The entire package is supplied in an attractive bezel assembly for simplified panel mounting. The user has an option of hard wiring directly to the board or using a standard edge card connector (Part No. 501-0700-005 — solder type terminations or Part No. 501-0700-009 — PC or wire wrap terminations).

The display is also available without the character generators, Part No. 749-08XX. These basic modules will also display 64 alpha-numeric characters when used in conjunction with any suitable ASCII ROM as shown in Fig. 1.

A ₆	A ₅	A ₄	A ₃	A ₂	A ₁	Resultant Display	A ₆	A ₅	A ₄	A ₃	A ₂	A ₁	Resultant Display
0	0	0	0	0	0	@	1	0	0	0	0	0	
0	0	0	0	0	1	A	1	0	0	0	0	1	!
0	0	0	0	1	0	B	1	0	0	0	1	0	"
0	0	0	0	1	1	C	1	0	0	0	1	1	#
0	0	0	1	0	0	D	1	0	0	1	0	0	\$
0	0	0	1	0	1	E	1	0	0	1	0	1	%
0	0	0	1	1	0	F	1	0	0	1	1	0	&
0	0	0	1	1	1	G	1	0	0	1	1	1	'
0	0	1	0	0	0	H	1	0	1	0	0	0	(
0	0	1	0	0	1	I	1	0	1	0	0	1)
0	0	1	0	1	0	J	1	0	1	0	1	0	*
0	0	1	0	1	1	K	1	0	1	0	1	1	+
0	0	1	1	0	0	L	1	0	1	1	0	0	,
0	0	1	1	0	1	M	1	0	1	1	0	1	-
0	0	1	1	1	0	N	1	0	1	1	1	0	:
0	0	1	1	1	1	O	1	0	1	1	1	1	/
0	1	0	0	0	0	P	1	1	0	0	0	0	∅
0	1	0	0	0	1	Q	1	1	0	0	0	1	1
0	1	0	0	1	0	R	1	1	0	0	1	0	2
0	1	0	0	1	1	S	1	1	0	0	1	1	3
0	1	0	1	0	0	T	1	1	0	1	0	0	4
0	1	0	1	0	1	U	1	1	0	1	0	1	5
0	1	0	1	1	0	V	1	1	0	1	1	0	6
0	1	0	1	1	1	W	1	1	0	1	1	1	7
0	1	1	0	0	0	X	1	1	1	0	0	0	8
0	1	1	0	0	1	Y	1	1	1	0	0	1	9
0	1	1	0	1	0	Z	1	1	1	0	1	0	:
0	1	1	0	1	1	[1	1	1	0	1	1	;
0	1	1	1	0	0	\	1	1	1	1	0	0	<
0	1	1	1	0	1]	1	1	1	1	0	1	=
0	1	1	1	1	0	^	1	1	1	1	1	0	>
0	1	1	1	1	1	-	1	1	1	1	1	1	?

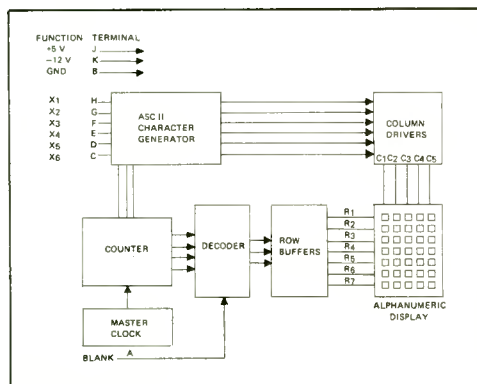

Fig. 1

Dimensions

749-08XX and 749-13XX Series

5x7 dot matrix Alphanumeric Display

.300" character height

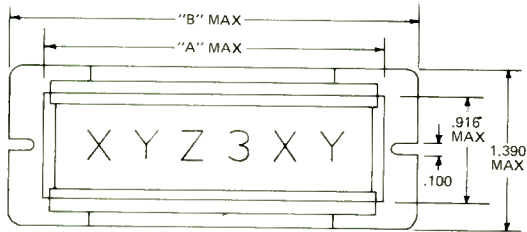

749-08XX-___

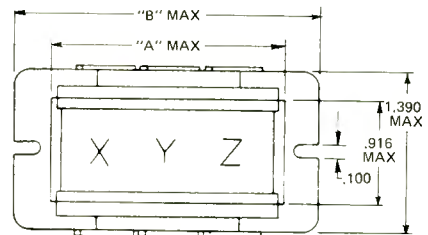

749-13XX-___

Decimals $\pm .007$

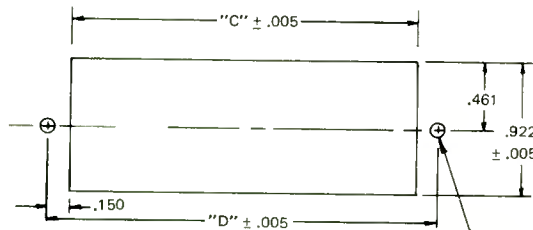

CLEARANCE FOR # 2-56 SCREW



749-08XX-___

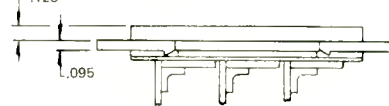

749-13XX-___

HOLE PATTERN FOR PRINTED CIRCUIT BOARD

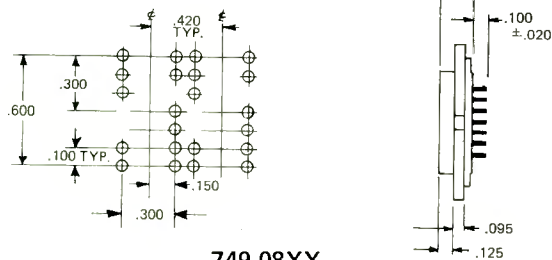

749-08XX-___

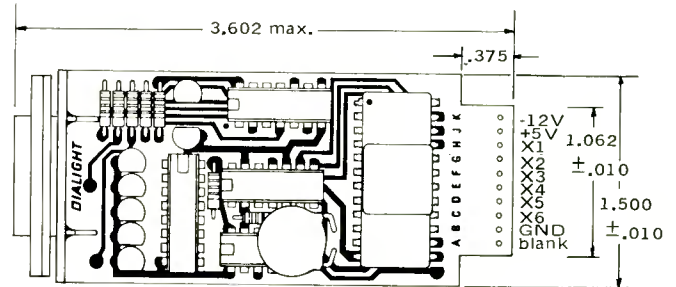

749-13XX-___

CATALOG NUMBER	* CHAR-ACTERS	DIMENSIONS			
		A	B	C	D
749-0801	1	.951	1.559	.958	1.259
749-0802	2	1.372	1.980	1.379	1.680
749-0803	3	1.793	2.401	1.800	2.101
749-0804	4	2.214	2.822	2.221	2.522
749-0805	5	2.635	3.243	2.642	2.943
749-0806	6	3.056	3.664	3.063	3.364
749-0807	7	3.477	4.085	3.484	3.785
749-0808	8	3.898	4.506	3.905	4.206
749-0809	9	4.319	4.927	4.326	4.627
749-0810	10	4.740	5.348	4.747	5.048

CATALOG NUMBER	* CHAR-ACTERS	DIMENSIONS			
		A	B	C	D
749-1301	1	1.093	1.701	1.100	1.401
749-1302	2	1.656	2.264	1.663	1.964
749-1303	3	2.219	2.827	2.226	2.527
749-1304	4	2.780	3.388	2.787	3.088
749-1305	5	3.345	3.953	3.352	3.653
749-1306	6	3.908	4.516	3.915	4.216
749-1307	7	4.471	5.079	4.478	4.779
749-1308	8	5.034	5.642	5.041	5.342
749-1309	9	5.596	6.204	5.603	5.904
749-1310	10	6.160	6.768	6.167	6.468

*For assemblies with more than 10 characters, consult factory.

749-12XX Series Hexadecimal Display

270" character height



Features

- .270" high character
- Left and right hand decimals
- High brightness single plane, with wide angle visibility
- Internal TTL MSI chip with latch, decoder and driver
- Constant current drive for hexadecimal characters
- Operates from 5V or 6V supply
- Separate LED and logic power supplies may be used
- Virtually immune to shock and vibration

General Description

The 749-12XX series hexadecimal display consists of 4x7 LED characters with externally driven left and right hand decimal points in a stylish black bezel for simplified panel mounting. Each character has an integral TTL MSI chip with a 4 bit latch and decoder/driver, all in a 14 pin package.

The LED driver outputs are designed to maintain a relatively constant on-level current of approximately 5 mA through each of the LEDs forming the character. This drive current is virtually independent of the LED supply voltage within the recommended operating conditions. The drive current may be varied, resulting in changes of luminous intensity, by varying the logic supply voltage within the specified range. The decimal point anodes are connected to the LED supply and the cathodes to the external pins. As there is no current limiting built into the decimal point circuits, this must be provided externally if used.

A description of the functions of the inputs of each character follows:

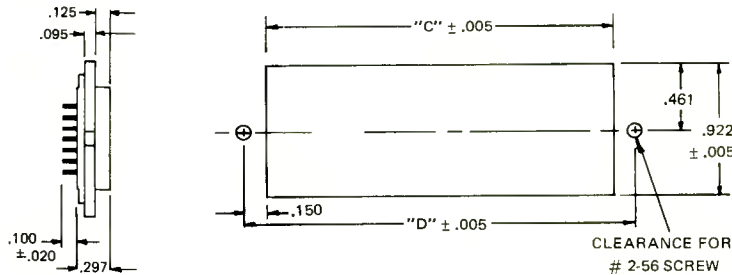
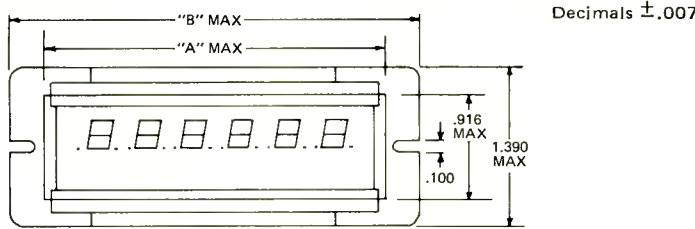

CATALOG NUMBER	* CHARACTERS	DIMENSIONS			
		A	B	C	D
749-1201	1	.951	1.559	.958	1.259
749-1202	2	1.372	1.980	1.379	1.680
749-1203	3	1.793	2.401	1.800	2.101
749-1204	4	2.214	2.822	2.221	2.522
749-1205	5	2.635	3.243	2.642	2.943
749-1206	6	3.056	3.664	3.063	3.364
749-1207	7	3.477	4.085	3.484	3.785
749-1208	8	3.898	4.506	3.905	4.206
749-1209	9	4.319	4.927	4.326	4.627
749-1210	10	4.740	5.348	4.747	5.048

* For assemblies with more than 10 characters, consult factory.

HOLE PATTERN FOR PRINTED CIRCUIT BOARD

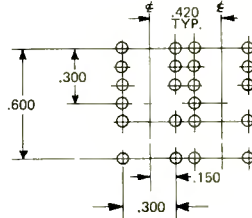

FUNCTION	PIN NO.	DESCRIPTION
LATCH STROBE INPUT	5	When low, the data in the latches follow the data on the latch data inputs. When high, the data in the latches will not change. If the display is blanked and then restored while the enable input is high, the previous character will again be displayed.
BLANKING INPUT	8	When high, the display is blanked regardless of the levels of the other inputs. When low, a character is displayed as determined by the data in the latches. The blanking input may be pulsed for intensity modulation.
LATCH DATA INPUTS (A, B, C, D)	3, 2, 13, 12	Data on these inputs are entered into the latches when the enable input is low. The binary weights of these inputs are A = 1, B = 2, C = 4, D = 8.
DECIMAL POINT CATHODES	4, 10	These LEDs are not connected to the logic chip. If a decimal point is used, an external resistor or other current-limiting mechanism must be connected in series with it.
LED SUPPLY	1	This connection permits the user to save on regulated VCC current by using a separate LED supply, or it may be externally connected to the logic supply (VCC).
LOGIC SUPPLY (VCC)	14	Separate VCC connection for the logic chip.
COMMON GROUND	7	This is the negative terminal for all logic and LED currents except for the decimal points.

Resultant display for the values of the binary data in the latches

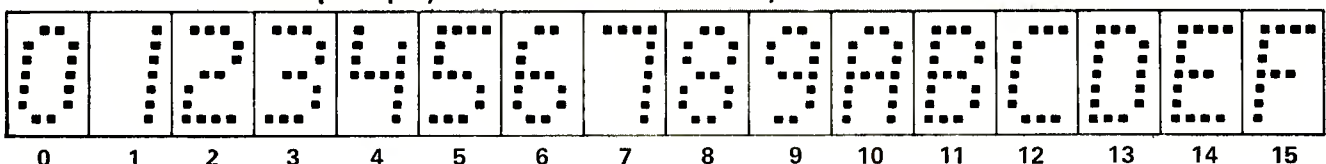

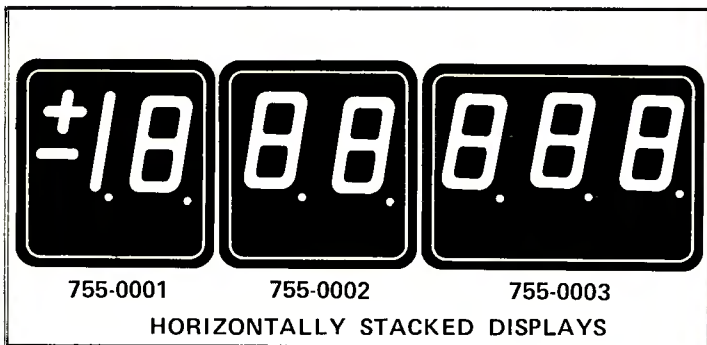

755 Series Planar Readout Displays

character height .550"



755-0001



755-0002



755-0003

Features

- Orange-neon glow (red is available with the use of filters)
- High brightness (210 foot lamberts nominal)
- High contrast ratio
- Non-segmented—continuous character font
- Wide viewing angle
- .550" character height viewable at 40 feet
- Life expectancy of 10 years
- Resistant to shock and vibration
- Low power dissipation
- Low cost
- Listed in Underwriter's recognized components index

Description

The .550" Gas Discharge Display is exceptionally bright and not washed out even in direct sunlight. The orange-neon glow and non-segmented continuous character font minimize eye fatigue while enhancing readability. The 755 series has a keep-alive cathode which provides an internal ion source that reduces re-ionization time to less than 30 microseconds, reduces anode supply voltage and improves the operation of the display in dark environments and at low temperature.

Applications

The 755 series is especially well suited to applications requiring continuous viewing as well as operation in high ambient light conditions.

Typical Applications

- Electronic cash registers
- Credit card verifiers
- Electronic scales
- Instruments, meters and counters
- Industrial control equipment
- Electronic thermometers
- Automatic test equipment
- TV channel indicators
- Communication equipment

750 Series— .550" gas discharge displays with decoder/drivers: please consult factory.

759 Series— .550" gas discharge displays with decoder/drivers in bezel display: please consult factory.

755 Series segment designations and pin connections

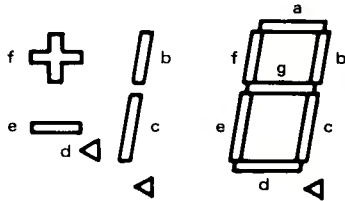

Segment/Symbol	Pin Number
a/*	1
b/b	2
c/c	3
d/decimal	4
e/minus sign	5
f/plus sign	6
g/*	7
decimal	8
anode	9
Keep-alive	10
cathode	

*Not used in half digit

DIGIT DESIGNATIONS

755-0001

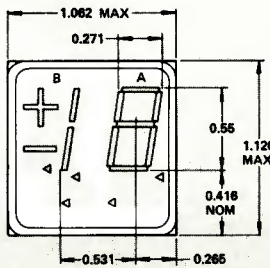

755-0002

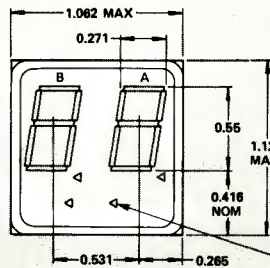

755-0003

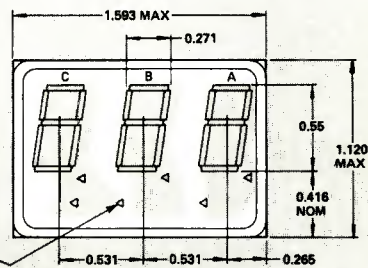

KEEP ALIVE PINS
ONE/DISPLAY
POSITION
(TYPICAL)

Shaded areas indicate anode patterns

PIN DESIGNATIONS AND LOCATIONS

All digit and pin designations are viewed from front of display

755-0001 & 755-0002

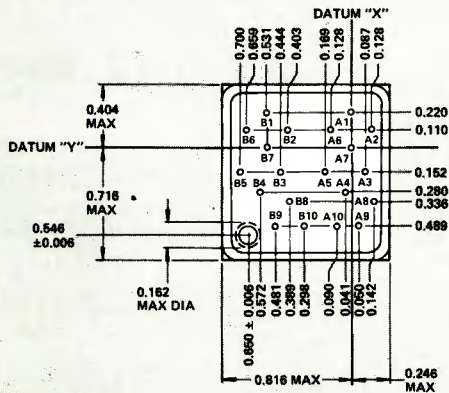

755-0003

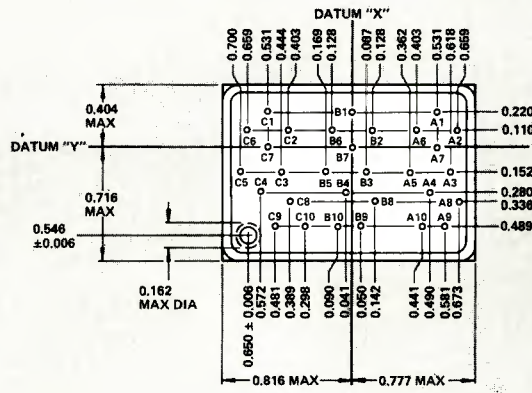

END VIEW

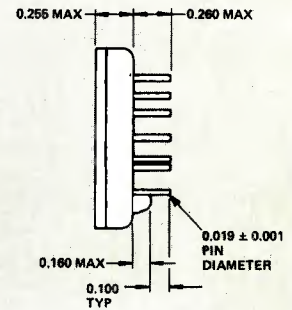

Notes:

- Pin locations shown are nominal (approximately ± 0.003 " tolerance). Allowances should be made for location tolerance by size of pc board hole diameter. For ease of insertion and solderability, recommend pc board hole diameter of 0.028-0.031.
- For even centerline spacing of digits in separate envelopes, recommend that comparable pins on adjacent digits be spaced 0.531 inch minimum. Allow 0.020 inch between adjacent display envelopes for ease of insertion, and to compensate for vibration or shock during processing, or for tolerances in circuit board manufacture.

755 Series specifications

DC Characteristics	Minimum	Typical	Maximum	Recommended Current limiting resistor values
Anode Supply Voltage (1)	160 Vdc	180 Vdc	Note 2	2200 Ω
Cathode Current—per segment (4)	130 μ A	330 μ A	420 μ A	
Cathode Current—Decimal Point (8)	65 μ A	135 μ A	190 μ A	430K Ω
Cathode Current—Plus Sign (8)	260 μ A	585 μ A	820 μ A	68K Ω
Cathode Current—Minus Sign (8)	120 μ A	270 μ A	380 μ A	150K Ω
Cathode Current—Keep Alive (9)	10 μ A	50 μ A	—	600K Ω
Anode to-Anode Differential Voltage (3)	—	—	14 Vdc	
Anode to-Cathode Voltage Drop (I _{segment} =330 μ A)	—	135 Vdc	—	
Power Dissipation—(with all segments lighted @ 330 μ A typical) (4)	—	350 mW	—	
Operating Temperature	0°C	—	70°C	
Storage Temperature	-55°C	—	125°C	
Lead Temperature (solder)	—	—	250°C for 10 sec.	

Multiplex Characteristics ⁽⁵⁾	Minimum	Typical	Maximum
Anode On Time ⁽⁶⁾	80 μ sec	200 μ sec	—
Interdigit Blanking Time (I _{segment} = 850 μ A @ 180 V)	40 μ sec	55 μ sec	—
Refresh Period	—	—	Note 7
Anode Supply Voltage	160 Vdc	180 Vdc	Note 2

Notes:

- After the display has ionized, the voltage drop is approximately 135 volts. Typical cathode current of 330 μ A is assumed.
- Anode supply voltage (including ripple) should not exceed 200 Vdc when display is used with 704-1607 decoder/driver.
- Lighted cathodes on all digits with independent current limiting. For bussed cathodes (multiplexed operation), 90 volts is permissible.
- Currents up to 1.5 times the typical current may be used, however, life expectancy may be reduced by operation at excessively higher currents. For multiplexed operation (time shared) segment currents may be increased to 1.25 mA with 0.25 or smaller duty cycles.
- Blanking requirements are strongly dependent upon the mode of multiplex operation and upon the segment current used.
- Anode On Time assumes typical keep - alive current and typical anode supply voltages.
- Keep - alive is recommended in all multiplex applications. Three (3) milli-seconds is typical without keep-alive. Ten (10) milli-seconds is typical with keep-alive.
- When a decimal point, plus or minus sign is required, it will function independent of the decoder/driver. The appropriate connection is tied to ground through the recommended current limiting resistor.
- Only one keep - alive cathode is required to be energized per envelope. The remaining pin or pins can be open circuited.

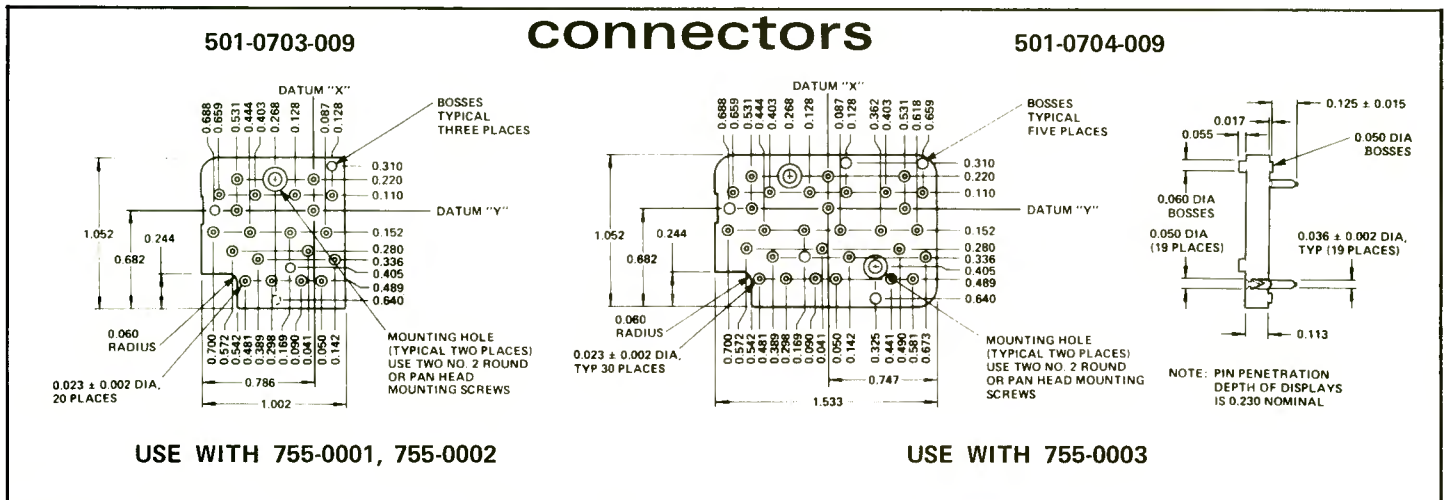

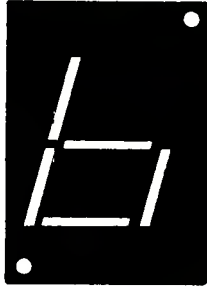

Incandescent and Neon Numeric Readouts

General Purpose Modular Design

The basic Dialco Readout Module combines maximum display capability with simple construction, simplicity in driving circuitry and low power requirement. The brightly lighted bars of the seven segment matrix may be selectively illuminated in twenty combinations. Ten useful letters are displayed in addition to the ten numbers, zero through nine.

A novel concept in efficient optical elements makes possible a presentation of exceptional brightness while employing light sources of low power and long life.

Unfailing Lamp Performance

Exceptional reliability is demanded of the seven light sources which illuminate the matrix bars in these modules. It has been possible to obtain long and failure-free operation by choosing special lamps, neon and incandescent, which have unique characteristics.



The neon lamp, used at higher voltages, is a seasoned and selected T-2 type, equipped with midget flanged base. These lamps are accurately described as "unfailing" since they do not have any mode of sudden failure. Their brightness is maintained at close to its initial value for thousands of hours. A noticeable or rapid decline in brightness is the signal for replacement.



The incandescent lamps used for low voltage circuits have been specially selected for the various voltage levels and feature low current operation and low filament temperatures with resultant high reliability.

Displays are bright and crisp, and are available with filters in a full range of colors.

System for Complete Display

The choice of modules with identical frontal area and mounting holes permits an assembled Readout of any desired capability. Modules may have decimal point or colon as an integral element. A compatible module displays a switchable plus-minus sign of the same dimensions as the numbers.

An auxiliary module for captions provides a lighted area for photographic transparency. A single character may be placed in the full area, or individually illuminated sections may display up to six words or symbols, selectively.

Module construction is simple and rugged. The case consists of a front half which is permanently mounted and a rear portion that detaches for lamp access on removal of two screws. Light gathering cells, and the lamps that enter from the rear to illuminate them, are housed in the front half of the Module. The rear portion carries the spring contact members for common and individual lamp connections, and the terminal board.

Incandescent and Neon Numeric Readouts

Versatility combined with Simplicity of Control

Not only are the ten digits displayed, but also letters. The combinations of lighted matrix bars which produce these twenty characters are shown by the Dialco Code Table. Lower case letters are assigned to the seven segments and they also identify the terminals on the back of the module.

Binary Coded Decimal Translation

BCD to 7 line decoder drivers are now available in IC packages from most IC manufacturers. These interface directly with the Dialco modules, resulting in displays of utmost simplicity and highest reliability.

Decimal Input

For the situation where there is decimal input, it is easy to convert to seven line by the use of diodes. Small circuit boards are listed for high and low voltage lamps and for power input of either polarity.

Encoding Switch

A single deck switch provides coded input over seven lines. The digits, zero through nine, are displayed as the thumbwheel goes through its ten settings.

Counting with Steppers

The combination of a seven input module with a seven cam stepping relay provides a low cost and reliable counting method. Actually an eighth cam is added to drive the next decade. This permits any total count (of pulses to the lowest decade).

Code table

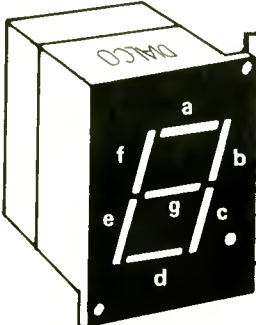

Light These Segments	To Display These Characters																			
	1	2	3	4	5	6	7	8	9	0	A	C	E	F	H	J	L	P	U	Y
a		•	•		•		•	•	•	•	•	•	•	•					•	
b	•	•	•	•			•	•	•	•	•	•						•	•	•
c	•															•	•			•
d		•	•		•					•		•	•			•	•			•
e		•				•		•		•	•	•	•	•	•	•	•	•	•	•
f				•	•	•	•	•	•	•	•	•	•	•	•	•	•	•	•	•
g		•	•	•	•	•		•	•		•	•	•	•				•	•	

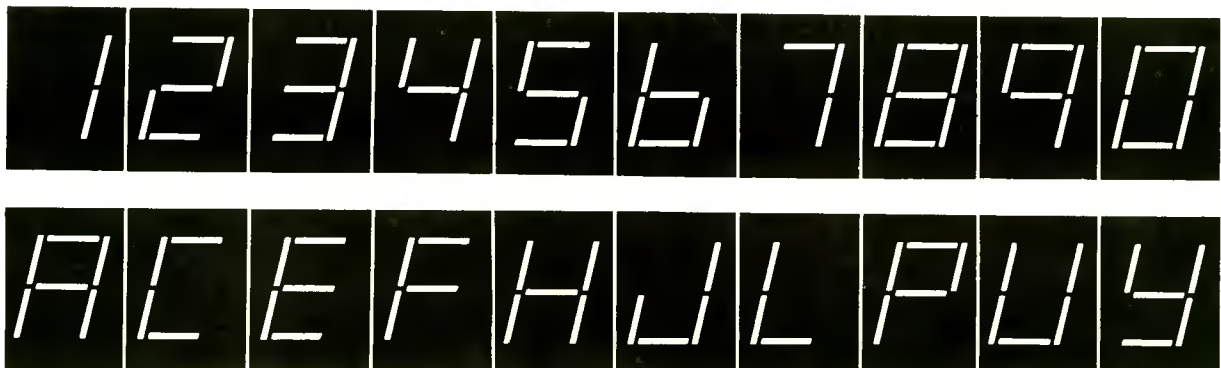

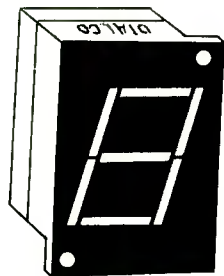

U.S. Pat. No. 3,210,876

710 series Incandescent Numeric Readout character height: one inch

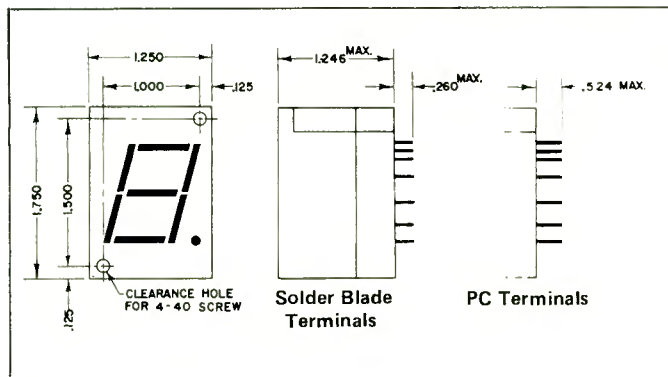

Features

- Displays 10 numbers and 10 letters
- Bold one inch characters
- Compatible caption modules

Effectiveness

Readouts assembled of the 710 Series Modules are the most legible displays possible in presentations of one-inch characters. The bold angular digits and letters provide error-free reading at over 30 feet and are well suited to close viewing.

Only characters displayed, by luminous bars emitting in a plane surface, can provide such wide angle reading accuracy. When viewed through their special non-glare filter, the lighted segments have high contrast to the background and those not lighted are virtually invisible.

Universal application

The 710 Series Modules are simplified to increase their range of application. They are made in two halves and are separable at the plane of the lamp holders. The seven lamps (or eight with integral decimal) are retained in the front portion while the rear portion houses the terminals. Both solder blade and printed circuit types are available.

The user may design for permanent mounting of either front or rear parts on a common support. If rear parts are movable, they are connected by flexible wiring. If front portions are detachable, the terminals of the fixed rear sections may be connected by use of printed wiring boards.

Low cost to quantity user

The 710 Series provides versatile display with one basic module. Two useful options are available: a similar module with integral point in the lower position, after the digit, for display as a decimal; or an inverted form where the point is in the upper position ahead of the digit for use as a colon. It is, of course, necessary to use a pair of these for the full colon. Decimal point and colon are presented in a normal relation to the digits.

All variations in conditions are accommodated by changes only in the lamp usage; that is, selection of the applicable lamp type and the external set of resistors to provide voltage reduction to assure very long life.

The universality of these modules has permitted economies that result in low module cost.

Lamp supply voltages

The patented optical devices that gather light, and make useful so much of the total lamp emission, permit the use of low powered light sources.

The lamp holders accept only T-1 3/4 bulbs with midget flanged base. See the Lamp Selection Table on following page. Rapid change of digits (by switching lamps on and off) has no adverse effect on lamp life.

710 series Incandescent Numeric Readout Character Height : One Inch



Lamp selection

Lamps may be specified separately or will be installed in modules if so ordered. The below listed lamps are those most suitable for optimum results. The 710 module has been specifically designed to accept these lamps.

The most used lamp is No. 344, which we supply as a seasoned and selected lamp of high reliability. This lamp is applicable directly to voltage in the range 15 ± 1 volts. The same lamp is recommended for use with suitable external resistor on higher voltage circuits. The table below provides lamp selections and performance data.

Seven lamps are required for the segmented display modules plus one additional for optional Modules with decimal or colon.

Status Displays require four or six lamps.

Lamp Selection Table

Lamp choice			Performance in readout		
Power supply volts	Recommended resistor	Lamp number	volts	current	* Average life hours
5	None	521-9058	5	30 mA	10,000
5	None	7332	5	60 mA	60,000
6	None	380	6	40 mA	50,000
10	81	367X	8	40 mA	20,000
14-16	None	344	15	18 mA	50,000
24-28	680	344	15	18 mA	50,000
160	39K	A1H	—	2.2 mA	20,000+

* Ratings of lamps are taken from published catalogs of leading lamp manufacturers.

Rated life is generally recognized as the 50% failure point of a group of lamps tested under static laboratory conditions, with the voltage closely regulated at the design value. This may not necessarily agree with the service life of a lamp where the effects of temperature, shock, vibration and voltage fluctuations may result in a shorter than rated life.

Ordering 710 series modules

Select basic modules and optional modules with decimal as required. For display of colon, order one each of the decimal and colon modules.

For display of plus-minus sign of full character size, specify Plus-Minus Module as listed below. For Caption Modules displaying plus and minus in combination with other symbols, see 711 series Catalog sheet.

A 1" display face, for low cost mounting on PC boards is also available. This unit accommodates either midget flanged based incandescent or unbased neon lamps. For data, see catalog sheet "Display Face for Printed Circuit Board mounting".

Description	Catalog No. * without lamp	With lamp #344	With lamp #380	with lamp #521-9058
Basic Module	710-0300-005	710-0300-025	710-0300-015	710-0300-075
Same with DECIMAL	710-0301-005	710-0301-025	710-0301-015	710-0301-075
Same with COLON	710-0302-005	710-0302-025	710-0302-015	710-0302-075
PLUS-MINUS Module	710-0305-005	710-0305-025	710-0305-015	710-0305-075
Same with DECIMAL	710-0304-005	710-0304-025	710-0304-015	710-0304-075

* Change the last digit of catalog number suffix to 9 for PC terminals. Example. 710-0300-009.

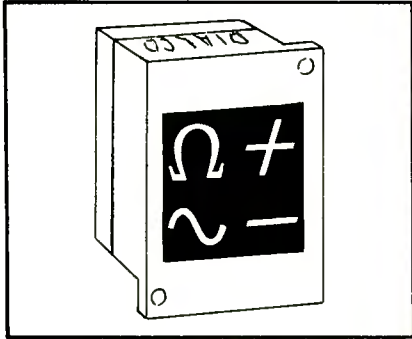

711 series Status Display

with 4 or 6 message areas

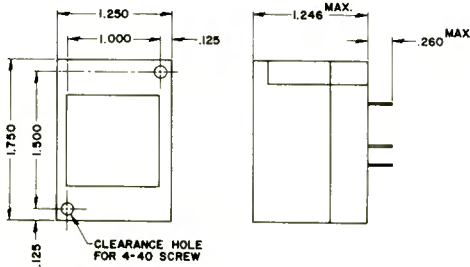

An auxiliary Module provides a back lighted transparency that displays an explanatory caption. The lighted area may present a single message or it may be divided into 2, 3, 4 or 6 areas that are individually switchable. For example, by employing four separate sections, plus and minus sign may be presented one above the other, leaving two other areas for symbols or words (see illustration). Refer to Catalog Number 711-1855- . . . in the table below.

Whatever is displayed is seen through the same viewing window as the digital portion and is harmonious and of equal brightness.

Status Displays provide great flexibility since the display is produced photographically from an original master layout.

Complete catalog numbers cannot be given for custom Status Displays, since a suffix is necessary that identifies the special details. These formats are identified by their catalog numbers (with customer's 3 digit suffix blank).

Refer to catalog sheet "Assembly and Mounting - 710 and 711 series Readout Modules".

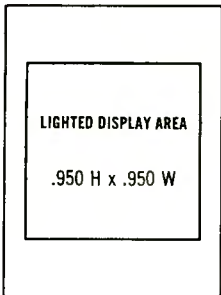

Typical caption display modules

	711-1845----		711-1885----		711-2245----
	711-1855----		711-1895----		711-2255----
	711-1865----		711-1905----		711-2265----
	711-1875----		711-1915----		711-2275----



accessories
for 710 and 711 Series
Readout Modules

**712 and 713 Series
Windows and Bars**

FOR USE WITH 710 and 711 SERIES MODULES ONLY

Mounting Bars (Pairs) (Catalog No. 713-0100-__ __)

Mounting Bars, used in pairs, provide a common base for all Modules comprising the readout and as a frame for holding the window. Refer to catalog sheet "Assembly and Mounting - 710 and 711 series Readout Modules".

To order Mounting Bars, add three digits, which indicates the number of Modules that are to be attached.

Example: 713-0100-008 (8 Modules)

Window—3 Basic Choices*

Plastic windows are designed for use with Mounting Brackets which provide the frame to hold them. The windows are red, green or amber plastic with a special non-glare finish. When neon lamps are specified, only red window should be used. Use of these windows (or filters) is essential to good contrast in character display. *Other window colors are available on application.

COLOR*	MATERIAL	SURFACE	CATALOG NO.
Red	Acrylic	Non-Glare	712-0103-____
Green	Acrylic	Non-Glare	712-0105-____
Amber	Acrylic	Non-Glare	712-0107-____

To order windows, add three digits which indicates the number of Modules that are to be covered. For example: 712-0103-008(8 modules).

EMI/RFI Shielding

When the panel opening, which is required to permit viewing the display, becomes a problem because of emission of interference, it is readily possible to apply a well grounded screen over the opening.

Some reduction in visibility results but the sacrifice is small and the attenuation is generally satisfactory.

Reference should be made to recommended method of mounting employing Mounting Bars and Windows. The screen, which provides shielding, is inserted between Modules and the rear surface of the Bars and back of the Window. Effective grounding is obtained. All that remains is to prepare the rear surface of the panel so that good contact is obtained when the complete Readout assembly is attached. Since the screen is a simple rectangular piece with two holes per module to clear the Module attachments, it can be fabricated of a variety of materials and meshes. Unless otherwise specified, it is an aluminum wire screen of 30 x 30 mesh and .0085 dia. wire.

assembly and mounting

710 and 711 series

Readout Modules



for 710 and 711 SERIES MODULES PROVIDING LAMP ACCESS FROM REAR

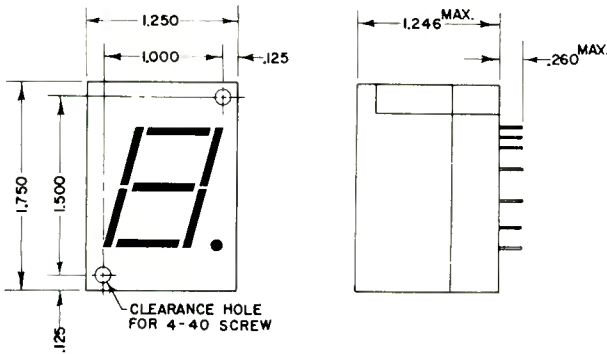

Character and Status Display are readily assembled into a group on a common base by the use of a pair of Mounting Bars as illustrated. The Bars serve to frame the window and to limit its vertical and lateral movement. The specified panel opening is smaller than the window. After making an assembly of the several Modules into a Readout, using the screws supplied with the Mounting Bars, it may be attached to the panel by any preferred fastening method. The Mounting Bars are provided with two mounting holes each for mounting up to 7 Modules. In longer Bars, there are three holes in each. The third hole is centered between the other two.

Space Required

The height, width and depth of the 710 and 711 Series Modules is shown above. The assembly of a group of the Modules requires lateral clearance equal to 1.25" times the number of Modules assembled plus 0.27" (total) for the slight extension of the Mounting Bars at each of the assembly.

The web of the Bars extends .42" above and below the Modules so that .84" is added to 1.75" height for a vertical dimension overall of 2.59".

Considerably more than the Module depth dimension must be allowed to permit the rear half of the Module to be backed away for lamp access.

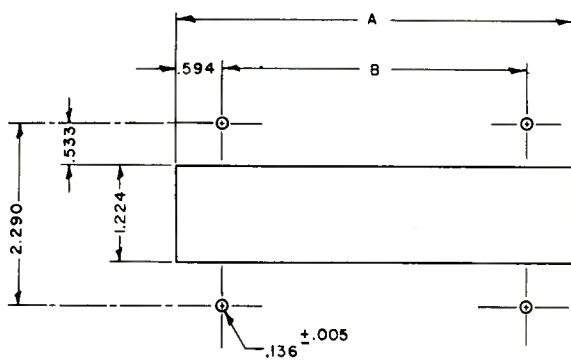
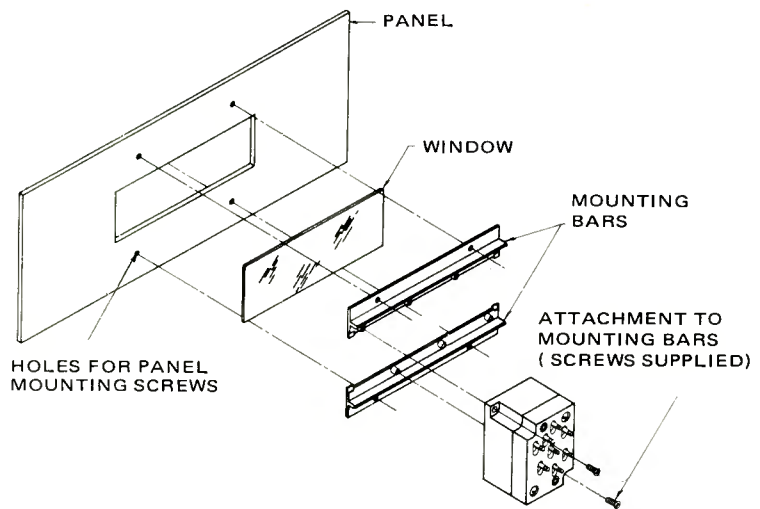

Preparation of the Panel

The Readout is viewed through a panel opening whose size is shown. The variable length and mounting screw locations are shown by the table for Readouts of 2 to 10 Modules.

Number of modules	Dim. "A"	Dim. "B"
2	2.438	1.250
3	3.688	2.500
4	4.938	3.750
5	6.188	5.000
6	7.438	6.250
7	8.688	7.500
8	9.938	8.750
9	11.188	10.000
10	12.438	11.250

Display Face for Printed Circuit Board mounting

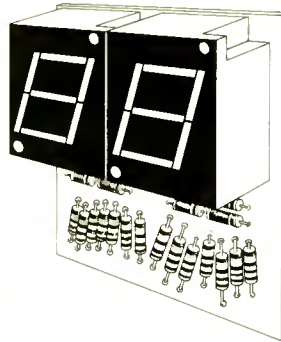

LOW COST APPROACH WITH EASE OF INSTALLATION

Display faces for printed circuit board mounting are also available for those who wish to use Dialight readouts on printed circuit boards of their own design. This is a low cost approach to a display featuring high quality and ease of installation. It is especially recommended for use with unbased neon lamps (NE2H-1) insuring a bright, bold reading display of highest reliability (information on P.C. board mounting of unbased lamps is available upon request).

All accessories offered for use with the standard readout assemblies may also be used with the P.C. board mounted modules.

Ordering information

710-0306 Basic module	710-0311 Plus-minus
710-0307 With decimal	711 series Status-Display--
710-0310 Plus-minus with decimal	Same configurations available as in standard units

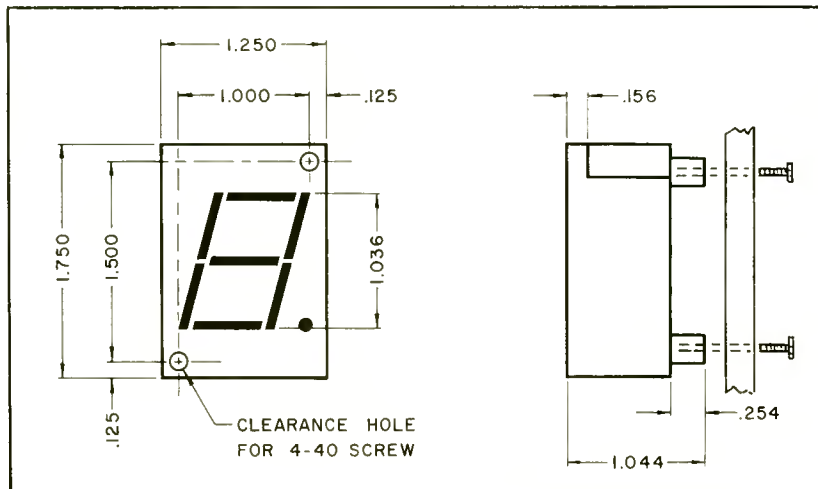

BCD to Seven Segment Decoder Drivers

704-1549 - drives solid state LED readouts and incandescent lamps.

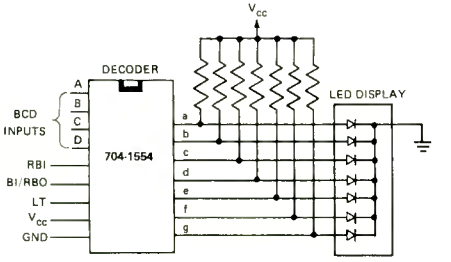
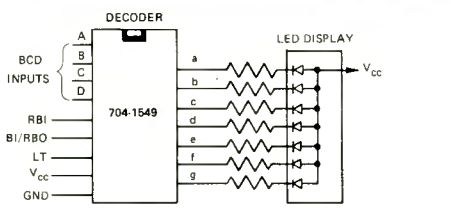
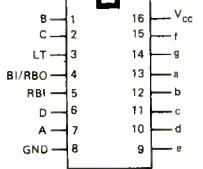
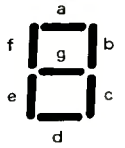
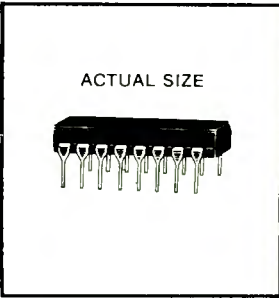

Features

- BCD inputs compatible with DTL and TTL devices
- Monolithic MSI Integrated Circuit
- Lamp Test
- Ripple blanking capability
- Intensity control

The 704-1549 and 704-1554 are seven segment decoder-drivers designed to convert four lines of 8421 BCD code into the appropriate outputs which will drive seven segmented readouts. Both the 704-1549 and 704-1554 decoders contain provisions for automatic leading and/or trailing edge zero suppression (RBI and RBO); and an active low input Lamp Test which over-rides all other inputs, except BI, to check the display. In addition, the BI input is also available for controlling the brightness of the display by modulating the input from an external variable duty cycle source.

The outputs of the 704-1549 decoder are open collector transistors with active low outputs able to drive all lamps up to a maximum of 15 volts with a sinking capability of 30 mA.

The active high outputs of the 704-1554 decoder provide typical source current of 2 mA per output.

Operating Characteristics (Ambient Temperature 25° C)

Supply Voltage, V_{cc}	5 ± 0.5 V
Supply Current	55 mA
Logic '1' } BCD, LT, RBI Logic '0' } Inputs	2.0 To 5.5 V 0.0 To 0.8 V, Sink 1.6 mA
Logic '1' } BI/RBO Logic '0' } Output	2.4 V Min., @ 200 µA 0.4 V Max., Sink 8.0 mA
OUTPUTS a-g 704-1549	
Sink Current (Note 1)	20 mA, $V_{ON} = 0.4$ V Max. ('ON' State)
Voltage, V_{OFF}	15 V Max., @ 250 µA ('OFF' State)
OUTPUTS a-g 704-1554	
Voltage (Note 2)	2.4 V Min., @ 0.4 mA ('ON' State)
Source Current	2 mA, @ $V_{OUT} = 0.85$ V ('ON' State)
Sink Current	10 mA Max., $V_{OUT} = 0.4$ V ('OFF' State)
Temperature Range	0° To 70° C

Note 1. The outputs a-g are open collector outputs which can sink 30 mA in the "ON" state and withstand +15V in the "OFF" state.
Note 2. The outputs a-g are active high passive pull-up outputs.

DECIMAL OR FUNCTION	INPUTS				BI/RBO	RESULTANT DISPLAY
	LT	RBI	D C B A			
0	1	1	0	0	0	0
1	1	X	0	0	0	1
2	1	X	0	0	1	0
3	1	X	0	0	1	1
4	1	X	0	1	0	0
5	1	X	0	1	0	1
6	1	X	0	1	1	0
7	1	X	0	1	1	1
8	1	X	1	0	0	0
9	1	X	1	0	0	1
BI	X	X	X	X	X	0
RBI	1	0	0	0	0	0
LT	0	X	X	X	X	1

'1' = HIGH LEVEL
'0' = LOW LEVEL
'X' = ANY LEVEL

- BI/RBO is wire-and logic serving as an input and/or output
- Active low configuration for the 704-1549 decoder active high configuration for the 704-1554 decoder

Decoder/Drivers

704-1549 Use with
710 Series
718 Series
730-0003, 730-0004,
730-0008, 730-0009
745-0003, 745-0006

Outline Drawing

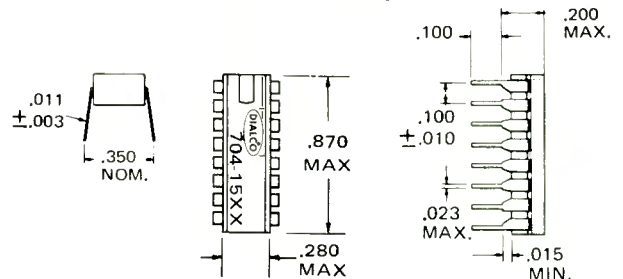

NOTE

Leads are for insertion in hole rows on .300" centers. They are purposely shipped with .350" spacing in order to provide sufficient tension necessary to secure the package in the board during soldering.

Printed in U.S.A.
Copyright 1974 by Dialight, Brooklyn, N.Y. 11237

Dialight reserves the right to make changes at anytime in order to improve design and to supply the best product possible.

704-1607 Decoder/Driver

For 755 Series Planar Readout Displays



TRUTH TABLE

DECIMAL OR FUNCTION	BCD INPUT				BI/RBO	SEGMENT DRIVE OUTPUT							DISPLAY	
	RBI	8	4	2		1	a	b	c	d	e	f		g
0	1	0	0	0	0	1	0	0	0	0	0	0	1	0
1	X	0	0	0	1	1	1	0	0	1	1	1	1	1
2	X	0	0	1	0	1	0	0	1	0	0	1	0	0
3	X	0	0	1	1	1	0	0	0	0	1	1	0	0
4	X	0	1	0	0	1	1	0	0	0	1	1	0	0
5	X	0	1	0	1	1	0	1	0	0	0	1	0	0
6	X	0	1	1	0	1	0	1	0	0	0	0	0	0
7	X	0	1	1	1	1	0	0	0	1	1	1	1	1
8	X	1	0	0	0	1	0	0	0	0	0	0	0	0
9	X	1	0	0	1	1	0	0	0	0	0	1	0	0
10	X	1	0	1	0	1	0	0	0	1	0	0	0	0
11	X	1	0	1	1	1	1	0	0	0	0	0	0	0
12	X	1	1	0	0	1	0	1	1	0	0	0	1	0
13	X	1	1	0	1	1	1	0	0	0	0	1	0	0
14	X	1	1	1	0	1	0	1	1	0	0	0	0	0
15	X	1	1	1	1	1	0	1	1	1	0	0	0	0
BI	X	X	X	X	X	0	1	1	1	1	1	1	1	1
RBI	0	0	0	0	0	0	1	1	1	1	1	1	1	1

NOTE: Logic "1" on all inputs and RBO is defined as the high TTL/DTL state. Logic "0" on outputs a - g is defined as the low or current sinking state (display on state). X is defined as "don't care" condition.

OUTLINE DRAWING

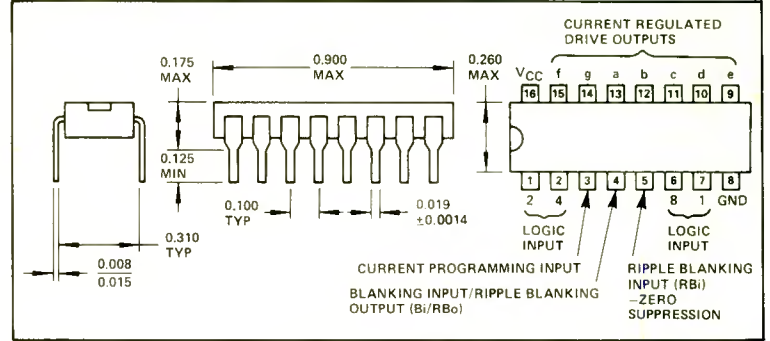

MAXIMUM RATINGS

Supply Voltage (V _{CC})	7.0 Volts dc
Input Voltage	5.5 Volts dc
Output Voltage	80 Volts dc
Output Current*	2 Milliampères (each output)
Operating Temperature	0°C to +70°C
Storage Temperature	-65°C to +150°C
Lead Temperature (soldering -10 seconds)	300°C

*For outputs programmed to operate as saturated switches.

ELECTRICAL CHARACTERISTICS

PARAMETER	CONDITIONS	MIN	TYP	MAX	UNITS
Logic "1" Input Voltage	V _{CC} = 4.75V	2.0			V
Logic "0" Input Voltage	V _{CC} = 4.75V			0.8	V
Logic "1" Output Voltage (RB)	V _{CC} = 4.75V, I _{OUT} = -200 μA	2.4	3.7		V
Logic "0" Output Voltage (RBO)	V _{CC} = 4.75V, I _{OUT} = 8 mA		0.13	0.4	V
Logic "1" Input Current (Except B)	V _{CC} = 5.25V, V _{IN} = 2.4V		2	15	μA
	V _{CC} = 5.25V, V _{IN} = 5.5V		4	400	μA
Logic "0" Input Current (Except B)	V _{CC} = 5.25V, V _{IN} = 0.4V	-300		-600	μA
Logic "0" Input Current (BI)	V _{CC} = 5.25V, V _{IN} = 0.4V		-1.2	-2.0	mA
Power Supply Current	V _{CC} = 5.25V, All Inputs = 0V, R _P = 2.2K		27	43	mA
Input Diode Clamp Voltage	V _{CC} = 5V, I _{IN} = -12 mA, T _A = 25°C		-0.9	-1.5	V
Segment Outputs:					
Outputs a, f, g On Current Ratio	All Outputs = 50V, Output b Curr. = Ref.	0.88	0.93	0.98	
Output c On Current Ratio	All Outputs = 50V, Output b Curr. = Ref.	1.19	1.25	1.31	
Output d On Current Ratio	All Outputs = 50V, Output b Curr. = Ref.	0.95	1.00	1.05	
Output e On Current Ratio	All Outputs = 50V, Output b Curr. = Ref.	1.04	1.10	1.16	
Output b On Current	V _{CC} = 5V, V _{OUT} b = 50V, T _A = 25°C, R _P = 18.1K	0.18	0.20	0.22	mA
	V _{CC} = 5V, V _{OUT} b = 50V, T _A = 25°C, R _P = 7.03K	0.45	0.50	0.55	mA
	V _{CC} = 5V, V _{OUT} b = 50V, T _A = 25°C, R _P = 3.40K	0.90	1.00	1.10	mA
	V _{CC} = 5V, V _{OUT} b = 50V, T _A = 25°C, R _P = 2.20K	1.45	1.50	1.65	mA
Output Saturation Voltage	V _{CC} = 4.75V, I _{OUT} = 2 mA, R _P = 1K ±5%		0.8	2.5	V
Output Leakage Current	V _{OUT} = 75V, BI = 0V		.003	3	μA
Output Breakdown Voltage	I _{OUT} = 250 μA, BI = 0V	80	110		V
Propagation Delays:					
BCD Input to Segment Output	V _{CC} = 5V, T _A = 25°C		0.4	10	μs
BI to Segment Output	V _{CC} = 5V, T _A = 25°C		0.4	10	μs
RBI to Segment Output	V _{CC} = 5V, T _A = 25°C		0.7	10	μs
RBI to RBO	V _{CC} = 5V, T _A = 25°C		0.4	10	μs
Program Resistor Value (From V _{CC} [Pin 16] to Programming Input [Pin 3])	DC Operation		11K		Ohms
	Multiplex Operation		2.4K		Ohms



for decimal input— Ten Line to Seven Line Converters

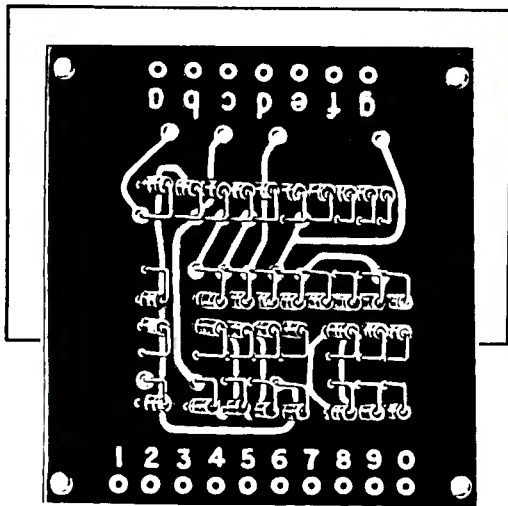

Where the user's input is inherently decimal, Dialight offers a converter to interface directly with its seven segment modules.

This circuitry is offered on a card 2-1/2" x 2-1/2". The diodes stand about 1/2" high on the 1/16" thick board and their connections extend through with 1/16" projecting. For adequate clearance in stacked arrangements about 3/4" space should be allowed per board. Holes in the four corners are 0.116" and centers are 1/8" from the edge.

Four catalog numbers are shown below to cover two voltage levels and two supply voltage polarities.

Matrix for decimal input

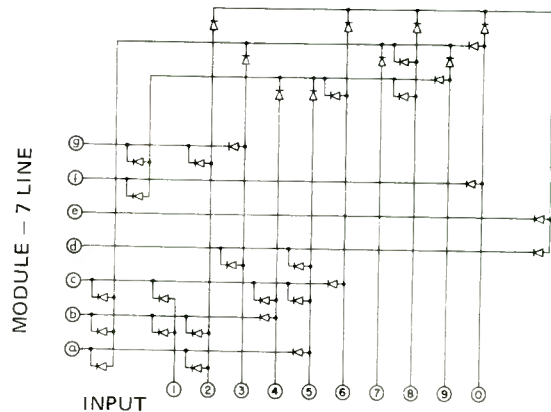

Catalog numbers

14-16 volts 24-28 volts		150-160 volts	
CONNECTION TO MODULE COMMON		CONNECTION TO MODULE COMMON	
NEGATIVE	POSITIVE	NEGATIVE	POSITIVE
704-1371-000	704-1372-000	704-1373-000	704-1374-000

Printed in U.S.A.
Copyright 1974 by Dialight, Brooklyn, N.Y. 11237

Dialight reserves the right to make changes at anytime in order to improve design and to supply the best product possible.

DIALIGHT
A NORTH AMERICAN PHILIPS COMPANY

203 HARRISON PLACE • BROOKLYN, N.Y. 11237 • 212 497-7600 • TWX: 710-584-5487



Available Now From These Stocking Distributors.

ARIZONA

Moltronics of Arizona, Inc.
Phoenix 602-272-7951

CALIFORNIA

Western Electromotive, Inc.
Culver City 213-870-7621

Westates Electronics Corp.
Chatsworth 213-341-4411

Newark Electronics, Inc.
Inglewood 213-678-0441

Bell Industries
Sunnyvale 408-734-8570

Fisher/Brownell
Santa Clara 408-244-6182

Richey Electronics, Inc.
Sun Valley 213-875-2862

COLORADO

Meter Master Inst. Corp.
Denver 303-722-5766

Newark-Denver Elect., Inc.
Denver 303-757-3351

CONNECTICUT

Surburban Supply Co.
Waterbury 203-757-1251

FLORIDA

Hammond Electronics, Inc.
Orlando 305-849-6060

ILLINOIS

Newark Electronics Corp.
Chicago 312-638-4411

INDIANA

Graham Electronic Supply
Indianapolis 317-634-8202

Radio Dist., Co.
South Bend 219-287-2911

LOUISIANA

Ralph's of Lafayette, Inc.
Lafayette 318-234-4507

MARYLAND

Radio Elec. Service Co.
Baltimore 301-823-0070

Cramer/EW Washington
Gaithersburg 301-948-0110

Pioneer Washington Elect.
Rockville 301-424-3300

MASSACHUSETTS

Sager Electrical Supply Co.
Boston 617-542-2281

Gerber Electronics, Inc.
Dedham 617-329-2400

Cramer Electronics, Inc.
Newton Centre 617-969-7700

MICHIGAN

Newark-Detroit Electronics
Detroit 313-548-0250

R S Electronics
Detroit 313-491-1000

MINNESOTA

Gopher Electronics Co.
St. Paul 612-645-0241

MISSOURI

LCOMP-Kansas City, Inc.
No. Kansas City 816-221-2400

LCOMP-St. Louis, Inc.
St. Louis 314-647-5505

NEBRASKA

Scott Electronic Supply
Lincoln 402-434-8308

NEW JERSEY

State Electronics
Hanover 201-887-2550

Newark Electronics
Kenilworth 201-272-8410

Resco Electronics
Pennsauken 609-662-4000

NEW YORK (Metropolitan area)

Ancar Electronics Supply, Inc.
Elmsford 914-592-7100

Arrow Electronics, Inc.
Farmingdale 516-694-6800

Peerless Radio Corp.
Lynbrook 516-593-2121

Harvey Radio Co., Inc.
Woodbury 516-921-8700

NEW YORK STATE

Summit Distributors, Inc.
Buffalo 716-884-3450

Summit Elect. of Rochester
Rochester 716-334-8110

NORTH CAROLINA

Hammond Elect. of Carolina
Greensboro 919-275-6391

Cramer/EW Inc.
Winston-Salem 919-725-8711

OHIO

Newark Cincinnati
Cincinnati 513-874-5115

Pioneer-Cleveland Elect.
Cleveland 216-587-3600

Hughes-Peters, Inc.
Columbus 614-294-5351

Stotts-Friedman Co.
Dayton 513-224-1111

OKLAHOMA

Radio Inc.
Tulsa 918-587-9124

OREGON

Almac/Stroom Elect.
Portland 503-292-3534

PENNSYLVANIA

Almo Elect. Corp.
Philadelphia 215-676-6000

Cameradio Electronics
Pittsburgh 412-288-2600

George D. Barbey Co.
Reading 215-376-7451

TENNESSEE

Radio Elec. Supply Co.
Kingsport 615-247-8111

TEXAS

Texas Instrument Supply
Dallas 214-238-6821

Newark Elect. Corp.
Garland 214-271-2511

Harrison Equip. Co., Inc.
Houston 713-224-9131

Newark Houston Elec. Corp.
Houston 713-782-4800

WASHINGTON

Almac/Stroom Electronics
Seattle 206-763-2300

WISCONSIN

Parts Mart Corp.
Milwaukee 414-276-4160

CANADA

BRITISH COLUMBIA

L.A. Varah Ltd.
Vancouver 604-873-3211

ONTARIO

Saynor Electronics Ltd.
Don Mills 416-445-2347

Wackid Radio TV Labs
Ottawa 613-728-1821

QUEBEC

Cesco Electronics Ltd.
Montreal 514-735-5511

Payette Radio Ltd.
Montreal 514-866-6681

DIALIGHT

A NORTH AMERICAN PHILIPS COMPANY

203 HARRISON PLACE • BROOKLYN, N.Y. 11237 • 212 497-7600 • TWX: 710-584-5487



745-0011 & 745-0012

DIALCO®

solid state LED readouts character height .100"

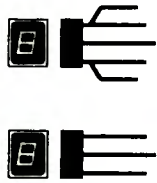

ACTUAL SIZE

Features

- .100" high characters
- Highly legible, bright red characters easily read at three to five feet; wide viewing angle.
- Gallium phosphide light source
- IC compatible, 2 to 3 volts dc.
- Solid state, extremely long life and high reliability.
- Tough, withstands rough production handling and user environments. Monolithic construction.
- Variable brightness
- Compact, 12 digits in less than 3" panel width.
- Attractive low cost, suitable for consumer applications.

General Information

Package

Black molded package with pins coming from the side opposite the readout (permits close mounting on p.c. boards). The 745 may be stacked vertically and horizontally for multi-digit high density displays.

Chips

Gallium phosphide monolithic digit chip, together with a separate decimal point chip to the lower right of the digit.

Appearance

Brightness variable to accommodate viewing conditions. Built-in filtering to enhance contrast. Wide-format character has large area to maximize viewing legibility. Digit size is .100" high, connected for seven-segment driving.

Reliability

Fully specified for environmental extremes in temperature and humidity. Solid state monolithic construction assures long trouble free operation.

Mechanical Features

Device is fully encapsulated, making the internal structure virtually immune to shock and vibration. External leads are preformed for printed circuit spacing. Solder-ability is fully guaranteed and specified. No special precautions needed in assembly and handling.

Viewing Angle

Easily viewed over 140°

Drive Logic

May be individually driven by DIALCO seven-segment decoder-driver (Catalog No. 704-1554), or in multiple-digit applications can be multiplexed for time-sharing of decoder. High peak current specification for up to 30 to 50 digits in a single array.

745-0011

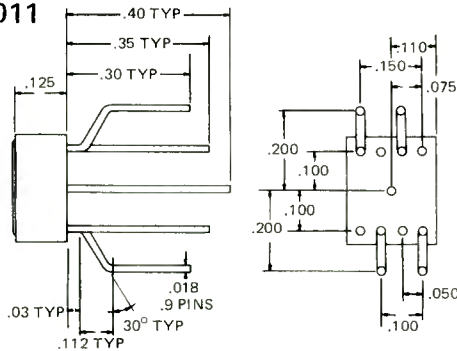

Reference Point

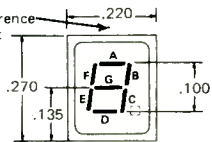

Pin Connections

- | | |
|-----------------|----------------------|
| Pin 1 Segment B | Pin 6 Segment C |
| Pin 2 Segment A | Pin 7 Segment D |
| Pin 3 Segment G | Pin 8 Segment E |
| Pin 4 Segment F | Pin 9 Common Cathode |
| Pin 5 Decimal | |

745-0012

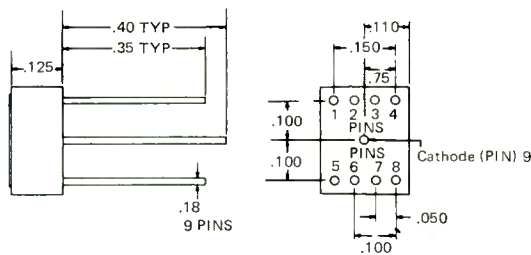

Typical Applications

Electronic thermometers, data-entry keyboards, speedometers, frequency meters, clocks, voltmeters, watches, credit-card verifiers, inventory controls, burglar alarms, industrial monitoring, appliance timers, TV channel indicators, calculators, telephone number monitors, radio station frequency indicators, military communications and control, counters of people or processes or events, test equipment, hotel or hospital room status boards, race lap counters, stopwatches, tachometers, elevator floor indicators, communications equipment, photographic light meters, etc.

745-0011 & 745-0012



DIALCO *DIALIGHT*® solid state LED readouts
character height .100"

SPECIFICATIONS

Typical Characteristics

Intensity: Typically .10 millicandela at 5 mA per segment
Forward Voltage at 10mA: 1.90V
Peak wavelength: 695nm (bright red)
Character height: .100 inches
Operating temperature range: -20°C to 80°C

Absolute Maximum Ratings

Reverse Voltage	3.0 Volts
Continuous Power Dissipation - derate 2.13mW/°C above 25°C	160mW
Average current per segment	10mA
Peak current per segment (pulse width <math><1\mu\text{sec}</math>, 1% Duty Cycle)	1A
Storage Temperature	-20°C to 80°C
Operating Temperature	-20°C to 80°C
Solder Temperature for 5 seconds	250°C @ 0.1" from seating plane

Electrical Characteristics/Segment or Decimal (25°C)

Symbol	Parameters	Min.	Typical	Max.	Units
V_f	Forward Voltage @ 10mA/Seg.	1.70	1.90	2.40	V
BV_r	Reverse Breakdown Voltage @ 50μA	3.0	—	—	V

Radiant Characteristics/Segment or Decimal (25°C)

Symbol	Parameters	Min.	Typical	Max.	Units
I	Luminous Intensity @ 5mA	25	100	—	μcd
λ_{pk}	Wavelength @ peak	—	—	695	nm
Δ	Spectral line half width	—	—	90	nm







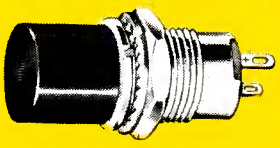
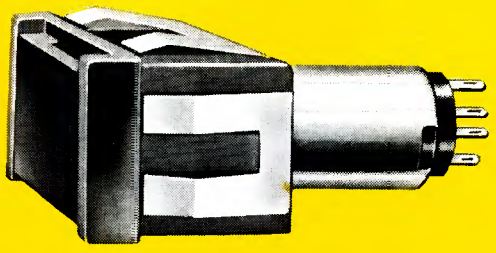

DIALIGHT

***Illuminated push button switches
and matching indicator lights***

UL listed

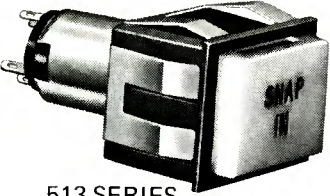

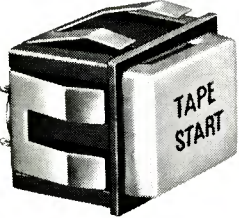
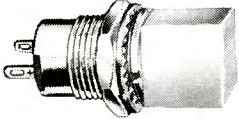
Catalog Index

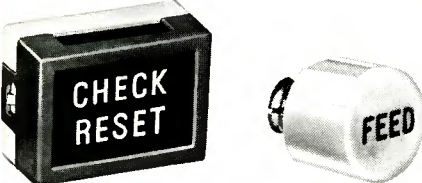
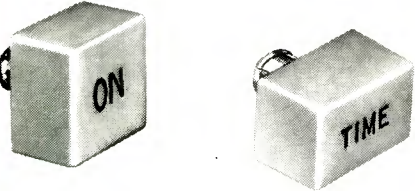
		MOUNT IN:		PAGE(S)
		ROUND CUTOUT .753 DIAM.	SQUARE CUTOUT .755 SQ. OR .880 SQ.	
SWITCHES	<p>SNAP-IN MOUNTING TYPE</p>  <p>A 513 SERIES</p>	<p>RECTANGULAR CUTOUT .870 x 1.110</p>	<ul style="list-style-type: none"> • Momentary non-snap; Alternate; Momentary snap • Low Level - Momentary non-snap; Momentary snap ;Alternate • D.P.D.T. Momentary snap Alternate snap 	<p>4-5</p> <p>5</p> <p>16-17</p>
	<p>PANEL MOUNTING TYPE</p>  <p>B 513 SERIES</p>	<p>15/32" OR 1/2"</p> <p>Clearance Hole</p>	<ul style="list-style-type: none"> • Momentary non-snap; Alternate; Momentary snap • Low Level - Momentary non-snap; Momentary snap ;Alternate • D.P.D.T. Momentary snap Alternate snap 	<p>6-7</p> <p>6-7</p> <p>16-17</p>
	<p>PANEL MOUNTING TYPE</p>  <p>C 913, 922 SERIES</p>	<p>3/8"</p> <p>Clearance Hole</p>	<ul style="list-style-type: none"> • Switch – momentary action – neon lamp • Switch – momentary action – LED lamp • Switch – momentary action – incandescent lamp 	<p>18-19</p> <p>19</p> <p>20-21</p>
MATCHING INDICATORS	<p>SNAP-IN MOUNTING TYPE</p>  <p>D 533 SERIES</p>	<p>ROUND CUTOUT .753 DIAM.</p> <p>SQUARE CUTOUT .755 SQ. OR .880 SQ.</p> <p>RECTANGULAR CUTOUT .870 x 1.110</p>	<ul style="list-style-type: none"> • For use with or without snap-in mounting switches (see A above). 	<p>14</p>
	<p>PANEL MOUNTING TYPE</p>  <p>E 183 SERIES</p>	<p>15/32" OR 1/2"</p> <p>Clearance Hole</p>	<ul style="list-style-type: none"> • For use with or without panel mounting switches (see B above). 	<p>15</p>
	<p>PANEL MOUNTING TYPE</p>  <p>F 911 SERIES</p>	<p>3/8"</p> <p>Clearance Hole</p>	<ul style="list-style-type: none"> • For use with or without panel mounting switches. • Neon • Incandescent 	<p>22</p> <p>22</p>
PUSH BUTTON CAPS			<ul style="list-style-type: none"> • For use with snap-in mounting switches and matching indicators (see A and D above). 	<p>8-9</p>
			<ul style="list-style-type: none"> • For use with panel mounting switches and matching indicators (see B and E above). 	<p>10-13</p>

Illuminated snap-in mounting push button switches and matching indicator lights



TYPICAL SWITCHES

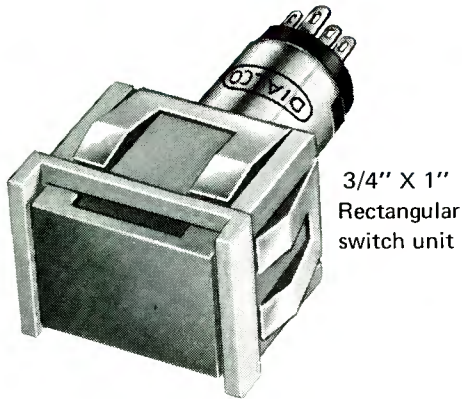

3/4" X 1"
Rectangular
switch unit

- Low profile
- Snap-in mounting for panels up to 3/16" thick.
- Rectangular bezel units interchangeable with most 4-lamp displays.
- Fingertip grip for ease of cap removal.
- Push button caps in full range of colors.
- Bezels with or without barrier in black, gray, dark gray or white.
- Switches are momentary or alternate action. Momentary (non-snap) switches are available N.O., N.C. or two circuit (one N.O., one N.C.). Alternate or momentary (snap) switches provide selection of S.P.D.T. or two circuit arrangements.

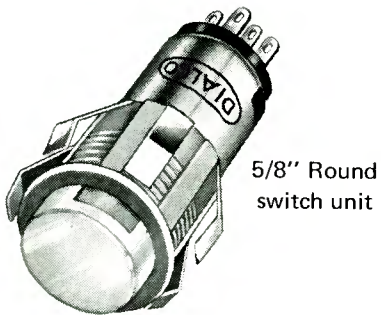

5/8" Round
switch unit

Snap-in bezel makes mounting faster . . . fingertip grip permits easy cap removal . . . lamp replacement is simpler than ever before.

1. Ease of installation. Switch or indicator light base is easily slipped into mounting cutout. The clip grips the panel. No tools are needed.

2. Ease of lamp insertion and replacement. The cap has a metal insert designed to receive the lamp. The lamp is inserted or replaced without the use of tools.

3. Ease of cap installation and removal. Fingertip grip simplifies insertion or replacement of push button cap.

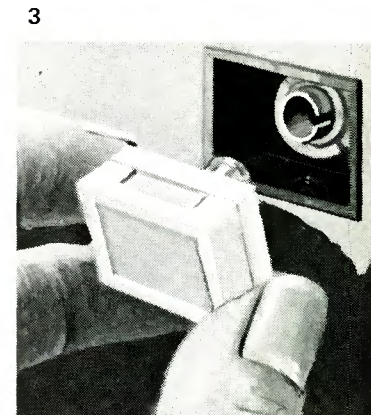
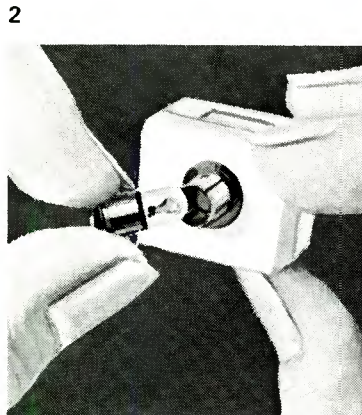
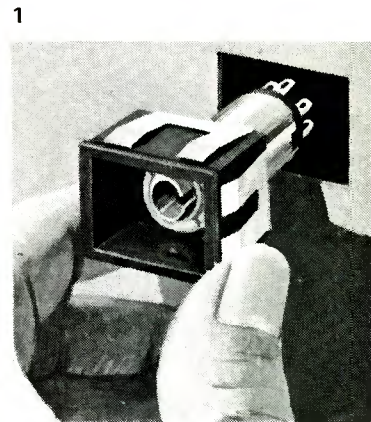

TYPICAL MATCHING INDICATOR

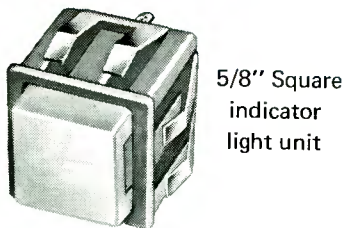

5/8" Square
indicator
light unit

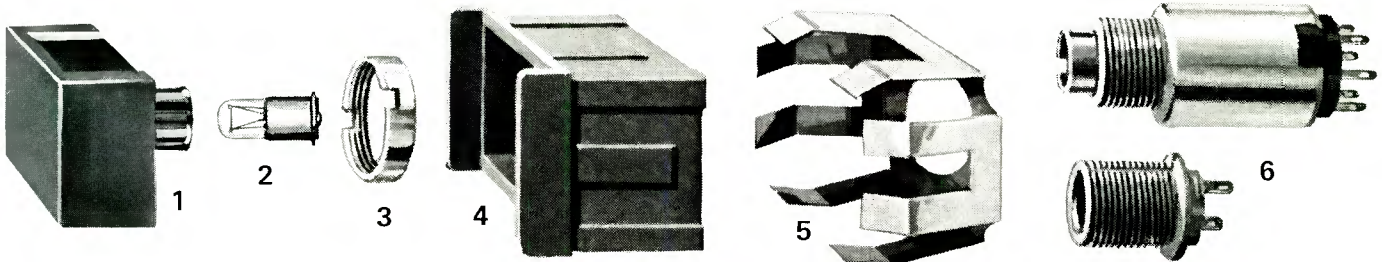

EXPLODED VIEW, left to right: 1. push button cap, 2. lamp 3. spanner ring, 4. bezel, 5. spring clip, 6. switch or indicator light.

Dialight push button switch specification

Snap-in Mounting Type

Materials and Finishes

- **Mounting Bushing:** Aluminum, clear anodize finish.
- **Contacts:** Coin silver, gold plated.
- **Terminals:** Brass, gold plated.
- **Insulation Resistance:** Greater than 1000 megohms at 500V DC.
- **Bezel:** Heat resistant plastic.
- **Clip:** Stainless steel.
- **Spanner Ring:** Aluminum, clear anodize finish.

How to order snap-in mounting switches

Before determining which momentary or alternate action switches to order, decide which push button cap shape is to be used (see pages 8 - 9). With this information, you can now select the switch base to meet your needs.

Please note that the chart below provides you with two columns, one designated "DWG. FIG. NO.", the other "CIRCUIT FIG. NO." Consult these columns and the designated drawings on the facing page to assist you in ordering the correct switch base for your application.

Examples:

- 513-0106-001
(for use with 300 Series Caps)
- 513-0107-001
(for use with 301 Series Caps)
- 513-0109-001
(for use with 303 or 534 Series Caps)
- 513-0110-001
(for use with 303 or 534 Series Caps)
- 513-0111-001
(for use with 306 Series Cap - or 300 Series Cap with Kap-Kover).

CATALOG NUMBER	CONTACT ARRANGEMENT	SWITCH ACTION	CONTACT RATING				LIFE AT RATED LOAD (000)	OPERATING FORCE	BUTTON TRAVEL	DWG. FIG. NO.	CIRCUIT FIG. NO.	DIM. "A"
			125V A.C.		30V D.C.							
			RESISTIVE	INDUCTIVE	RESISTIVE	INDUCTIVE						
513-0106-001	S.P.S.T. N.O.	Momentary Non-Snap	3 Amp.	-	3 Amp.	-	100	20 oz.	.100	1	6	1.820
513-0107-001	S.P.S.T. N.O.	Momentary Non-Snap	3 Amp.	-	3 Amp.	-	100	20 oz.	.100	2	6	1.820
513-0109-001	S.P.S.T. N.O.	Momentary Non-Snap	3 Amp.	-	3 Amp.	-	100	20 oz.	.100	3	6	1.820
513-0110-001	S.P.S.T. N.O.	Momentary Non-Snap	3 Amp.	-	3 Amp.	-	100	20 oz.	.100	4	6	1.820
513-0111-001	S.P.S.T. N.O.	Momentary Non-Snap	3 Amp.	-	3 Amp.	-	100	20 oz.	.100	5	6	1.820
513-0206-001	S.P.S.T. N.C.	Momentary Non-Snap	3 Amp.	-	3 Amp.	-	100	10 oz.	.100	1	7	1.820
513-0207-001	S.P.S.T. N.C.	Momentary Non-Snap	3 Amp.	-	3 Amp.	-	100	10 oz.	.100	2	7	1.820
513-0209-001	S.P.S.T. N.C.	Momentary Non-Snap	3 Amp.	-	3 Amp.	-	100	10 oz.	.100	3	7	1.820
513-0210-001	S.P.S.T. N.C.	Momentary Non-Snap	3 Amp.	-	3 Amp.	-	100	10 oz.	.100	4	7	1.820
513-0211-001	S.P.S.T. N.C.	Momentary Non-Snap	3 Amp.	-	3 Amp.	-	100	10 oz.	.100	5	7	1.820
513-0306-001	Two Circuit	Momentary Non-Snap	3 Amp.	-	3 Amp.	-	100	15 oz.	.100	1	8	1.820
513-0307-001	Two Circuit	Momentary Non-Snap	3 Amp.	-	3 Amp.	-	100	15 oz.	.100	2	8	1.820
513-0309-001	Two Circuit	Momentary Non-Snap	3 Amp.	-	3 Amp.	-	100	15 oz.	.100	3	8	1.820
513-0310-001	Two Circuit	Momentary Non-Snap	3 Amp.	-	3 Amp.	-	100	15 oz.	.100	4	8	1.820
513-0311-001	Two Circuit	Momentary Non-Snap	3 Amp.	-	3 Amp.	-	100	15 oz.	.100	5	8	1.820
513-1406-001	S.P.D.T.	Alternate	5 Amp.	2 Amp.	5 Amp.	2 Amp.	25	28 oz.	.106	1	9	2.335
513-1407-001	S.P.D.T.	Alternate	5 Amp.	2 Amp.	5 Amp.	2 Amp.	25	28 oz.	.106	2	9	2.335
513-1409-001	S.P.D.T.	Alternate	5 Amp.	2 Amp.	5 Amp.	2 Amp.	25	28 oz.	.106	3	9	2.335
513-1410-001	S.P.D.T.	Alternate	5 Amp.	2 Amp.	5 Amp.	2 Amp.	25	28 oz.	.106	4	9	2.335
513-1411-001	S.P.D.T.	Alternate	5 Amp.	2 Amp.	5 Amp.	2 Amp.	25	28 oz.	.106	5	9	2.335
513-1506-001	Two Circuit	Alternate	5 Amp.	2 Amp.	5 Amp.	2 Amp.	25	28 oz.	.106	1	8	2.335
513-1507-001	Two Circuit	Alternate	5 Amp.	2 Amp.	5 Amp.	2 Amp.	25	28 oz.	.106	2	8	2.335
513-1509-001	Two Circuit	Alternate	5 Amp.	2 Amp.	5 Amp.	2 Amp.	25	28 oz.	.106	3	8	2.335
513-1510-001	Two Circuit	Alternate	5 Amp.	2 Amp.	5 Amp.	2 Amp.	25	28 oz.	.106	4	8	2.335
513-1511-001	Two Circuit	Alternate	5 Amp.	2 Amp.	5 Amp.	2 Amp.	25	28 oz.	.106	5	8	2.335
513-1606-001	S.P.D.T.	Momentary Snap	5 Amp.	2 Amp.	5 Amp.	2 Amp.	50	12 oz.	.070	1	9	1.820
513-1607-001	S.P.D.T.	Momentary Snap	5 Amp.	2 Amp.	5 Amp.	2 Amp.	50	12 oz.	.070	2	9	1.820
513-1609-001	S.P.D.T.	Momentary Snap	5 Amp.	2 Amp.	5 Amp.	2 Amp.	50	12 oz.	.070	3	9	1.820
513-1610-001	S.P.D.T.	Momentary Snap	5 Amp.	2 Amp.	5 Amp.	2 Amp.	50	12 oz.	.070	4	9	1.820
513-1611-001	S.P.D.T.	Momentary Snap	5 Amp.	2 Amp.	5 Amp.	2 Amp.	50	12 oz.	.070	5	9	1.820
513-1706-001	Two Circuit	Momentary Snap	5 Amp.	2 Amp.	5 Amp.	2 Amp.	50	12 oz.	.070	1	10	1.820
513-1707-001	Two Circuit	Momentary Snap	5 Amp.	2 Amp.	5 Amp.	2 Amp.	50	12 oz.	.070	2	10	1.820
513-1709-001	Two Circuit	Momentary Snap	5 Amp.	2 Amp.	5 Amp.	2 Amp.	50	12 oz.	.070	3	10	1.820
513-1710-001	Two Circuit	Momentary Snap	5 Amp.	2 Amp.	5 Amp.	2 Amp.	50	12 oz.	.070	4	10	1.820
513-1711-001	Two Circuit	Momentary Snap	5 Amp.	2 Amp.	5 Amp.	2 Amp.	50	12 oz.	.070	5	10	1.820

NOTE: Above switches are listed in Underwriters' recognized components index.

The last digit in the catalog number indicates bezel color. Change this digit to designate the desired color. Example: 513-0207-004 (white bezel).

NUMBER	BEZEL COLOR
1	Black
2	Gray
3	Dark Gray
4	White

DWG. FIG. NO.	CAP SELECTION*
1	300 SERIES
2	301 SERIES
3	303 & 534 SERIES
4	303 & 534 SERIES
5	300 SERIES & KAP-KOVER; 306 SERIES ONLY

*See data on pages 8 & 9.

CIRCUIT SCHEMATICS

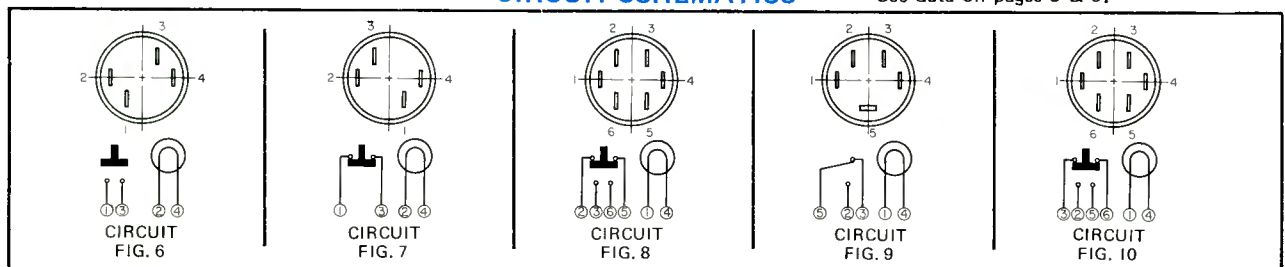

Snap-in Mounting Type

LOW LEVEL SWITCHES

These switches are designed specifically for use in the low voltage, low current regions (3-12V DC at 5-100 Ma.). Use of a heavy gold plating over the fine silver contacts insures low contact resistance and contact stability over the life of these switches.

CATALOG NUMBER	CONTACT ARRANGEMENT	SWITCH ACTION	LOW LEVEL □	LIFE AT RATED LOAD (000)	OPERATING FORCE	BUTTON TRAVEL	DWG. FIG. NO.	CIRCUIT FIG. NO.	DIM "A"
			CONTACT RATINGS						
513-0406-001	S.P.S.T. N.O.	Momentary Non-Snap	5-100 Ma.	100,	20 oz.	.100	1	6	1.820
513-0407-001	S.P.S.T. N.O.	Momentary Non-Snap	5-100 Ma.	100,	20 oz.	.100	2	6	1.820
513-0409-001	S.P.S.T. N.O.	Momentary Non-Snap	5-100 Ma.	100,	20 oz.	.100	3	6	1.820
513-0410-001	S.P.S.T. N.O.	Momentary Non-Snap	5-100 Ma.	100,	20 oz.	.100	4	6	1.820
513-0411-001	S.P.S.T. N.O.	Momentary Non-Snap	5-100 Ma.	100,	20 oz.	.100	5	6	1.820
513-0506-001	S.P.S.T. N.C.	Momentary Non-Snap	5-100 Ma.	100,	10 oz.	.100	1	7	1.820
513-0507-001	S.P.S.T. N.C.	Momentary Non-Snap	5-100 Ma.	100,	10 oz.	.100	2	7	1.820
513-0509-001	S.P.S.T. N.C.	Momentary Non-Snap	5-100 Ma.	100,	10 oz.	.100	3	7	1.820
513-0510-001	S.P.S.T. N.C.	Momentary Non-Snap	5-100 Ma.	100,	10 oz.	.100	4	7	1.820
513-0511-001	S.P.S.T. N.C.	Momentary Non-Snap	5-100 Ma.	100,	10 oz.	.100	5	7	1.820
513-0606-001	Two Circuit	Momentary Non-Snap	5-100 Ma.	100,	15 oz.	.100	1	8	1.820
513-0607-001	Two Circuit	Momentary Non-Snap	5-100 Ma.	100,	15 oz.	.100	2	8	1.820
513-0609-001	Two Circuit	Momentary Non-Snap	5-100 Ma.	100,	15 oz.	.100	3	8	1.820
513-0610-001	Two Circuit	Momentary Non-Snap	5-100 Ma.	100,	15 oz.	.100	4	8	1.820
513-0611-001	Two Circuit	Momentary Non-Snap	5-100 Ma.	100,	15 oz.	.100	5	8	1.820
513-1806-001	S.P.D.T.	Momentary Snap	5-100 Ma.	50,	12 oz.	.070	1	9	1.820
513-1807-001	S.P.D.T.	Momentary Snap	5-100 Ma.	50,	12 oz.	.070	2	9	1.820
513-1809-001	S.P.D.T.	Momentary Snap	5-100 Ma.	50,	12 oz.	.070	3	9	1.820
513-1810-001	S.P.D.T.	Momentary Snap	5-100 Ma.	50,	12 oz.	.070	4	9	1.820
513-1811-001	S.P.D.T.	Momentary Snap	5-100 Ma.	50,	12 oz.	.070	5	9	1.820
513-1906-001	Two Circuit	Momentary Snap	5-100 Ma.	50,	12 oz.	.070	1	10	1.820
513-1907-001	Two Circuit	Momentary Snap	5-100 Ma.	50,	12 oz.	.070	2	10	1.820
513-1909-001	Two Circuit	Momentary Snap	5-100 Ma.	50,	12 oz.	.070	3	10	1.820
513-1910-001	Two Circuit	Momentary Snap	5-100 Ma.	50,	12 oz.	.070	4	10	1.820
513-1911-001	Two Circuit	Momentary Snap	5-100 Ma.	50,	12 oz.	.070	5	10	1.820
513-2006-001	S.P.D.T.	Alternate Action	5-100 Ma.	25,	28 oz.	.106	1	9	2.335
513-2007-001	S.P.D.T.	Alternate Action	5-100 Ma.	25,	28 oz.	.106	2	9	2.335
513-2009-001	S.P.D.T.	Alternate Action	5-100 Ma.	25,	28 oz.	.106	3	9	2.335
513-2010-001	S.P.D.T.	Alternate Action	5-100 Ma.	25,	28 oz.	.106	4	9	2.335
513-2011-001	S.P.D.T.	Alternate Action	5-100 Ma.	25,	28 oz.	.106	5	9	2.335
513-2106-001	Two Circuit	Alternate Action	5-100 Ma.	25,	28 oz.	.106	1	8	2.335
513-2107-001	Two Circuit	Alternate Action	5-100 Ma.	25,	28 oz.	.106	2	8	2.335
513-2109-001	Two Circuit	Alternate Action	5-100 Ma.	25,	28 oz.	.106	3	8	2.335
513-2110-001	Two Circuit	Alternate Action	5-100 Ma.	25,	28 oz.	.106	4	8	2.335
513-2111-001	Two Circuit	Alternate Action	5-100 Ma.	25,	28 oz.	.106	5	8	2.335

□ For ratings under 5 Ma., consult factory.

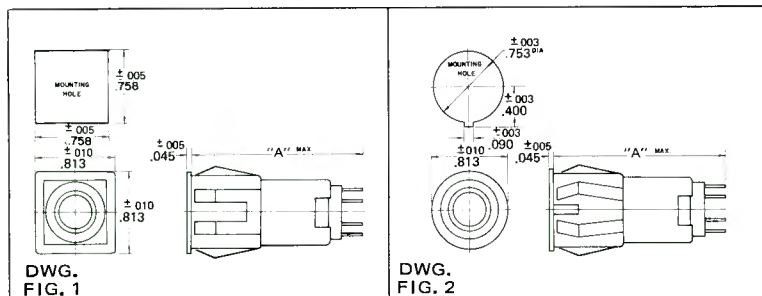

MATRIX MOUNTING DIMENSIONS

GROUP OF	DWG. FIG. 1	DWG. FIGS. 3 & 4		DWG. FIG. 5
	HORIZONTAL OR VERTICAL CUTOUT	HORIZONTAL CUTOUT	VERTICAL CUTOUT	HORIZONTAL OR VERTICAL CUTOUT
1	.758	1.110	.870	.883
2	1.576	2.279	1.799	1.826
3	2.399	3.453	2.733	2.774
4	3.222	4.627	3.667	3.722
5	4.045	5.801	4.601	4.670
6	4.868	6.975	5.535	5.618

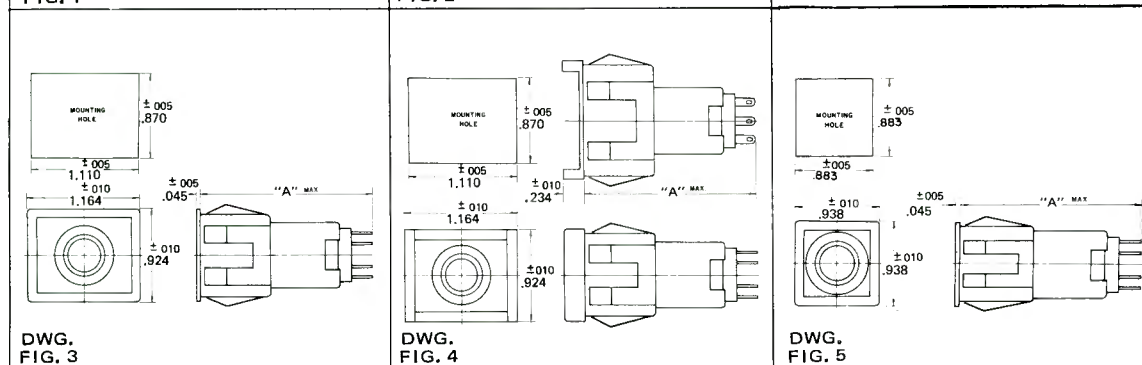

Dialight push button switch specifications and Panel Mounting Type

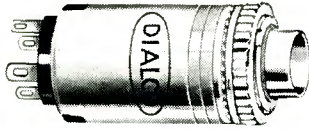

Switch base only

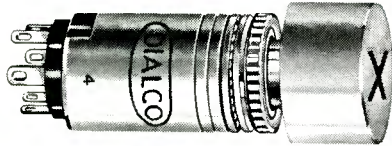

Switch base with push button cap

- Switches and Matching Lights are designed for single hole (keyed) mounting in panels up to 3/16" thick.
 - Switch bases may be mounted on a sub-panel and the cap inserted through an overlay panel for low-profile appearance.
 - Matching indicator lights use same push button caps – may be used as companions of switches – or independently.
 - Accommodate T-1 3/4 bulb with midget flanged base – incandescent, in a range of voltages to 28.
- Panel mtg. caps – see pages 10-13

HOW TO ORDER SWITCHES

Switch bases are ordered separately. Catalog numbers with appropriate characteristics and ratings are listed below. Outline drawings, circuit schematics and mounting instructions are given on the facing page.

CATALOG NUMBER	CONTACT ARRANGEMENT	SWITCH ACTION	CONTACT RATING				LIFE AT RATED LOAD (000)	OPERATING FORCE	BUTTON TRAVEL	CIRC. FIG. NO.	DIM. "A"
			125V A.C.		30V D.C.						
			RESISTIVE	INDUCTIVE	RESISTIVE	INDUCTIVE					
513-0101-604	S.P.S.T. N.O.	Momentary Non-Snap	3 Amp.	-----	3 Amp.	-----	100,	20 oz.	.100	1	1.468
*513-0104-604	S.P.S.T. N.O.	Momentary Non-Snap	3 Amp.	-----	3 Amp.	-----	100,	20 oz.	.100	1	1.468
†513-0105-604	S.P.S.T. N.O.	Momentary Non-Snap	3 Amp.	-----	3 Amp.	-----	100,	20 oz.	.100	1	1.468
▲513-0108-604	S.P.S.T. N.O.	Momentary Non-Snap	3 Amp.	-----	3 Amp.	-----	100,	20 oz.	.100	1	1.468
513-0201-604	S.P.S.T. N.C.	Momentary Non-Snap	3 Amp.	-----	3 Amp.	-----	100,	10 oz.	.100	2	1.468
*513-0204-604	S.P.S.T. N.C.	Momentary Non-Snap	3 Amp.	-----	3 Amp.	-----	100,	10 oz.	.100	2	1.468
†513-0205-604	S.P.S.T. N.C.	Momentary Non-Snap	3 Amp.	-----	3 Amp.	-----	100,	10 oz.	.100	2	1.468
▲513-0208-604	S.P.S.T. N.C.	Momentary Non-Snap	3 Amp.	-----	3 Amp.	-----	100,	10 oz.	.100	2	1.468
513-0301-604	Two Circuit	Momentary Non-Snap	3 Amp.	-----	3 Amp.	-----	100,	15 oz.	.100	3	1.468
*513-0304-604	Two Circuit	Momentary Non-Snap	3 Amp.	-----	3 Amp.	-----	100,	15 oz.	.100	3	1.468
†513-0305-604	Two Circuit	Momentary Non-Snap	3 Amp.	-----	3 Amp.	-----	100,	15 oz.	.100	3	1.468
▲513-0308-604	Two Circuit	Momentary Non-Snap	3 Amp.	-----	3 Amp.	-----	100,	15 oz.	.100	3	1.468
513-1401-604	S.P.D.T.	Alternate	5 Amp.	2 Amp.	5 Amp.	2 Amp.	25,	28 oz.	.106	4	1.969
▲513-1408-604	S.P.D.T.	Alternate	5 Amp.	2 Amp.	5 Amp.	2 Amp.	25,	28 oz.	.106	4	1.969
513-1501-604	Two Circuit	Alternate	5 Amp.	2 Amp.	5 Amp.	2 Amp.	25,	28 oz.	.106	3	1.969
▲513-1508-604	S.P.D.T.	Alternate	5 Amp.	2 Amp.	5 Amp.	2 Amp.	25,	28 oz.	.106	3	1.969
513-1601-604	S.P.D.T.	Momentary Snap	5 Amp.	2 Amp.	5 Amp.	2 Amp.	50,	12 oz.	.070	4	1.468
▲513-1608-604	S.P.D.T.	Momentary Snap	5 Amp.	2 Amp.	5 Amp.	2 Amp.	50,	12 oz.	.070	4	1.468
513-1701-604	Two Circuit	Momentary Snap	5 Amp.	2 Amp.	5 Amp.	2 Amp.	50,	12 oz.	.070	5	1.468
▲513-1708-604	Two Circuit	Momentary Snap	5 Amp.	2 Amp.	5 Amp.	2 Amp.	50,	12 oz.	.070	5	1.468

▲ Switch base with printed circuit terminals.

* For use with 192 Series screw-in push button caps only. Mount in 15/32" clearance hole.

† For use with 192 Series screw-in push button caps only. Mount in 1/2" clearance hole.

NOTE: Above switches are listed in Underwriters' recognized components index.

LOW LEVEL SWITCHES

These switches are designed specifically for use in the low voltage, low current regions (3-12V DC at 5-100 Ma.). Use of a heavy gold plating over the fine silver contacts insures low contact resistance and contact stability over the life of these switches.

CATALOG NUMBER	CONTACT ARRANGEMENT	SWITCH ACTION	LOW LEVEL □	LIFE AT RATED LOAD (000)	OPERATING FORCE	BUTTON TRAVEL	FIG.	DIM. "A"
			CONTACT RATINGS 3-12V D.C. RESISTIVE					
513-0401-604	S.P.S.T. N.O.	Momentary Non-Snap	5-100 Ma.	100,	20 oz.	.100	1	1.468
*513-0404-604	S.P.S.T. N.O.	Momentary Non-Snap	5-100 Ma.	100,	20 oz.	.100	1	1.468
†513-0405-604	S.P.S.T. N.O.	Momentary Non-Snap	5-100 Ma.	100,	20 oz.	.100	1	1.468
▲513-0408-604	S.P.S.T. N.O.	Momentary Non-Snap	5-100 Ma.	100,	20 oz.	.100	1	1.468
513-0501-604	S.P.S.T. N.C.	Momentary Non-Snap	5-100 Ma.	100,	10 oz.	.100	2	1.468
*513-0504-604	S.P.S.T. N.C.	Momentary Non-Snap	5-100 Ma.	100,	10 oz.	.100	2	1.468
†513-0505-604	S.P.S.T. N.C.	Momentary Non-Snap	5-100 Ma.	100,	10 oz.	.100	2	1.468
▲513-0508-604	S.P.S.T. N.C.	Momentary Non-Snap	5-100 Ma.	100,	10 oz.	.100	2	1.468
513-0601-604	Two Circuit	Momentary Non-Snap	5-100 Ma.	100,	15 oz.	.100	3	1.468
*513-0604-604	Two Circuit	Momentary Non-Snap	5-100 Ma.	100,	15 oz.	.100	3	1.468
†513-0605-604	Two Circuit	Momentary Non-Snap	5-100 Ma.	100,	15 oz.	.100	3	1.468
▲513-0608-604	Two Circuit	Momentary Non-Snap	5-100 Ma.	100,	15 oz.	.100	3	1.468
513-1801-604	S.P.D.T.	Momentary Snap	5-100 Ma.	100,	12 oz.	.070	4	1.468
▲513-1808-604	S.P.D.T.	Momentary Snap	5-100 Ma.	50,	12 oz.	.070	4	1.468
513-1901-604	Two Circuit	Momentary Snap	5-100 Ma.	50,	12 oz.	.070	5	1.468
▲513-1908-604	Two Circuit	Momentary Snap	5-100 Ma.	50,	12 oz.	.070	5	1.468
513-2001-604	S.P.D.T.	Alternate Action	5-100 Ma.	25,	28 oz.	.106	4	1.969
▲513-2008-604	S.P.D.T.	Alternate Action	5-100 Ma.	25,	28 oz.	.106	4	1.969
513-2101-604	Two Circuit	Alternate Action	5-100 Ma.	25,	28 oz.	.106	3	1.969
▲513-2108-604	Two Circuit	Alternate Action	5-100 Ma.	25,	28 oz.	.106	3	1.969

▲ Switch base with printed circuit terminals.
□ For ratings under 5 Ma., consult factory.

* For use with 192 Series screw-in push button caps only. Mount in 15/32" clearance hole.
† For use with 192 Series screw-in push button caps only. Mount in 1/2" clearance hole.

MATERIALS & FINISHES

- **Mounting Bushing:** Aluminum, clear anodize finish.
- **Contacts:** Coin silver, gold plated.
- **Terminals:** Brass, gold plated.
- **Insulation Resistance:** Greater than 1000 megohms at 500V DC.
- **Hardware:** Spacing Washers (aluminum) and Lock Ring (steel): Yellow iridescent chromate finish. Knurled Flange Nut – Aluminum, clear anodize finish; optional, black anodize finish. Internal-tooth Lockwasher – Phosphor bronze, white nickel finish.

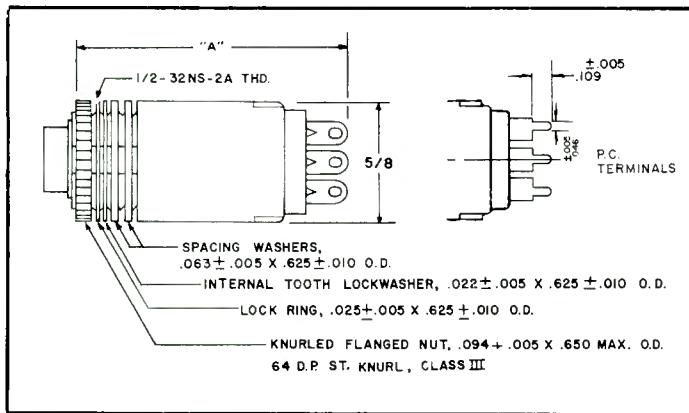

WRENCH: The threaded round knurled nuts used on the switch and matching indicator light bases have a knurl of these specifications: **64 D.P. ST. KNURL, CLASS III**. This wrench permits secure fastening of these products on mounting panels.

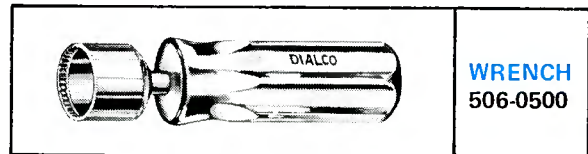

MOUNTING HOLE

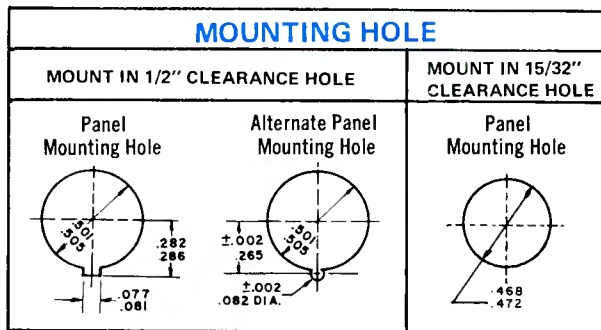

MOUNTING INSTRUCTIONS

PANEL THICKNESS	SPACING WASHERS
.063"	TWO
.125"	ONE
.188"	NONE

Switch bases for mounting in 15/32" clearance hole are not provided with spacing washers.

CIRCUIT SCHEMATICS

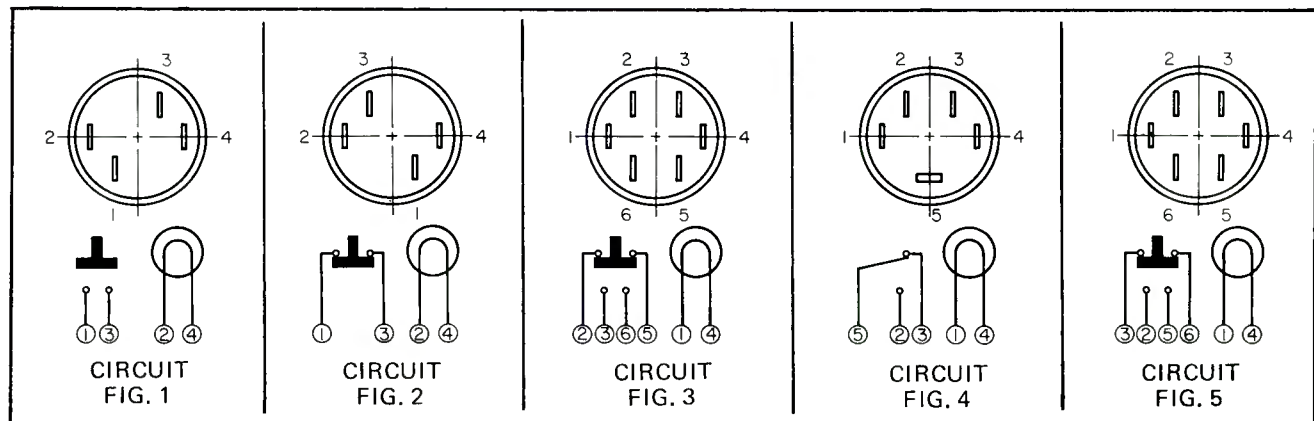

Dialight push button cap specifications and

For use with Snap-in Mounting Switches & Matching Indicators only.



The light source

The light source is the T-1 1/2 bulb with midget flanged base—incandescent—in a range of voltages from 5 to 28V.

Materials and finishes

• **Push Button Cap:** Plastic, fitted with brass shank, white nickel plated.

Ratings of lamps are taken from published catalogs of leading lamp manufacturers.

Rated life is generally recognized as the 50% failure point of a group of lamps tested under static laboratory conditions, with the voltage closely regulated at the design value. This may not necessarily agree with the service life of a lamp where the effects of temperature, shock, vibration and voltage fluctuations may result in a shorter than rated life.

MANUFACTURER'S RATINGS

Lamp No.	Volts	Amperes	Hours	Candle power
7332	5.0	.06	30,000	.05
*328	6.0	.20	1,000	.63
349	6.3	.20	5,000	.55
381	6.3	.20	20,000	.40
367X	10.0	.04	10,000	.08
330	14.0	.08	1,500	.50
382	14.0	.08	15,000	.30
370	18.0	.04	10,000	.15
*327	28.0	.04	4,000	.34
**387	28.0	.04	7,000	.30

* Conform to MS25237
** MS18209 (BuShips)

How to order push button caps

The charts below provide catalog numbers for the 300, 301, 303 and 306 Series translucent caps. If the cap selected is to have an engraved legend, be sure to consult page 23 for legend standards. Many options are offered with the 534 Series Push Button Cap. For this reason, the numbering system is given (see facing page), and you can select the desired features and arrive at the correct catalog number (s) to be ordered.

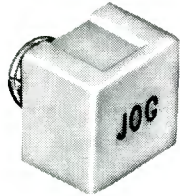
	5/8" SQUARE PUSH BUTTON CAPS 300 SERIES	Translucent Color	Without Legend	With Engraved Legend Black Fill	White Translucent with Colored Filter Without Legend	White Translucent with Colored Filter and Engraved Legend Black Fill
		Red	300-1871	300-6371	300-1861	300-6361
Green	300-1872	300-6372	300-1862	300-6362		
Yellow (Amber)	300-1873	300-6373	300-1863	300-6363		
Blue	300-1874	300-6374	300-1864	300-6364		
White	300-1875	300-6375	-	-		
Lt. Yellow	300-1876	300-6376	-	-		

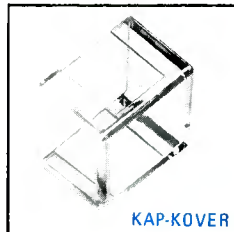

Use of 300 Series Push Button Caps with square bezel (see Switches: Page 5 - Fig. 5) or (Matching Indicators: Page 14 - Fig. 5) with clear colorless Kap-Kover (dimensional drawing on facing page) permit the user to insert or replace legends simply, on location. The Kap-Kover fits over the legend and the 300 Series push button cap, and is accommodated by the square bezel for snap-in mounting. The Kap-Kover, push button cap and bezel may be used with switches and matching indicators.

To order:

KAP-KOVER	CAT. NO.
Clear colorless	515-0300

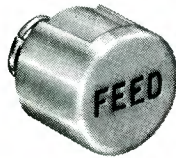
	5/8" ROUND PUSH BUTTON CAPS 301 SERIES	Translucent Color	Without Legend	With Engraved Legend Black Fill	White Translucent with Colored Filter Without Legend	White Translucent with Colored Filter and Engraved Legend Black Fill
		Red	301-1471	301-6571	301-1461	301-6561
Green	301-1472	301-6572	301-1462	301-6562		
Yellow (Amber)	301-1473	301-6573	301-1463	301-6563		
Blue	301-1474	301-6574	301-1464	301-6564		
White	301-1475	301-6575	-	-		
Lt. Yellow	301-1476	301-6576	-	-		

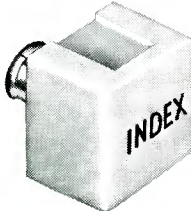
	3/4" SQUARE PUSH BUTTON CAPS 306 SERIES	Translucent Color	Without Legend	With Engraved Legend Black Fill	White Translucent with Colored Filter Without Legend	White Translucent with Colored Filter and Engraved Legend Black Fill
		Red	306-1871	306-6371	306-1861	306-6361
Green	306-1872	306-6372	306-1862	306-6362		
Yellow (Amber)	306-1873	306-6373	306-1863	306-6363		
Blue	306-1874	306-6374	306-1864	306-6364		
White	306-1875	306-6375	-	-		
Lt. Yellow	306-1876	306-6376	-	-		

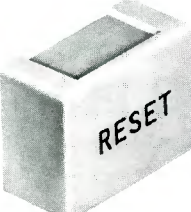
	3/4" X 1" RECTANGULAR PUSH BUTTON CAPS 303 SERIES	Translucent Color	Without Legend	With Engraved Legend Black Fill	White Translucent with Colored Filter Without Legend	White Translucent with Colored Filter and Engraved Legend Black Fill
		Red	303-3471	303-6371	303-3461	303-6361
Green	303-3472	303-6372	303-3462	303-6362		
Yellow (Amber)	303-3473	303-6373	303-3463	303-6363		
Blue	303-3474	303-6374	303-3464	303-6364		
White	303-3475	303-6375	-	-		
Lt. Yellow	303-3476	303-6376	-	-		

CAP SELECTION GUIDE — 534 SERIES, 3/4" x 1" RECTANGULAR

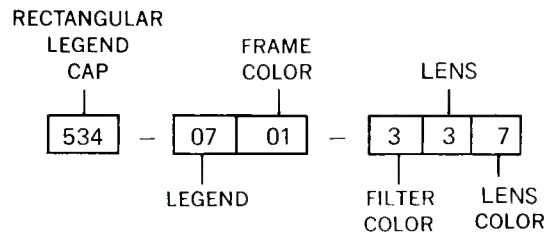
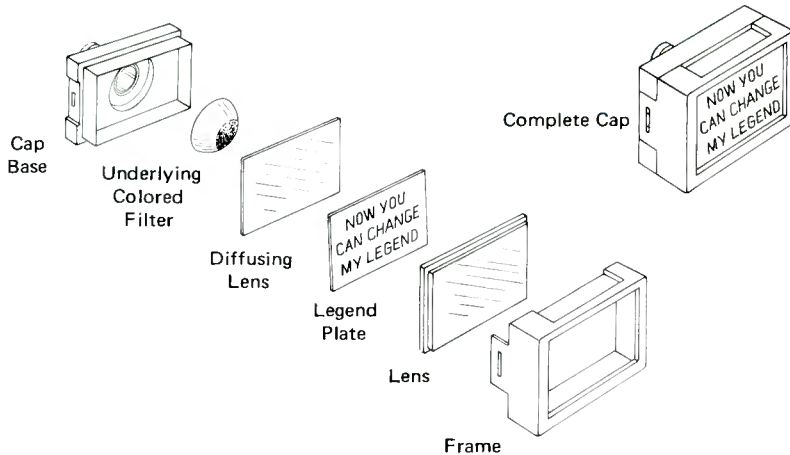

LEGEND	FRAME COLOR	FILTER COLOR	LENS	LENS COLOR
00—NONE		0—NONE		
01—FILM, POSITIVE (VISIBLE)	01—BLACK	1—RED		1—RED
02—FILM, NEGATIVE (VISIBLE)	02—GRAY	2—GREEN		2—GREEN
03—FILM, POSITIVE (HIDDEN)	03—DARK GRAY	3—YELLOW (AMBER)	3—TRANSPARENT	3—YELLOW (AMBER)
04—FILM, NEGATIVE (HIDDEN)	04—WHITE	4—BLUE		4—BLUE
05—ENGRAVE, POSITIVE (VISIBLE)	05—CLEAR			5—WHITE
06—ENGRAVE, POSITIVE (HIDDEN)				6—YELLOW, LIGHT
07—REPLACEABLE +			7—TRANSLUCENT	7—CLEAR
				9—GRAY*

* Gray cap color is used when hidden legend (either film or engraved) is specified.

EXAMPLES:

534-0401-139 (Hidden film legend with negative presentation. Legend is red against black

background when illuminated).

534-0604-239 (Hidden engraved legend with positive presentation. Legend is black against green background when illuminated).

534-0502-073 (Visible engraved legend with

positive presentation. Legend is black on translucent amber background).

534-0203-237 (Visible film legend with negative presentation. Legend is white on black background when not energized, green on black background when illuminated).

+ If you wish to make your own custom legend, specify as follows: 534-0705-X3X. Select and designate the appropriate catalog numbers for Filter Color (if any) and Cap Face Color respectively.

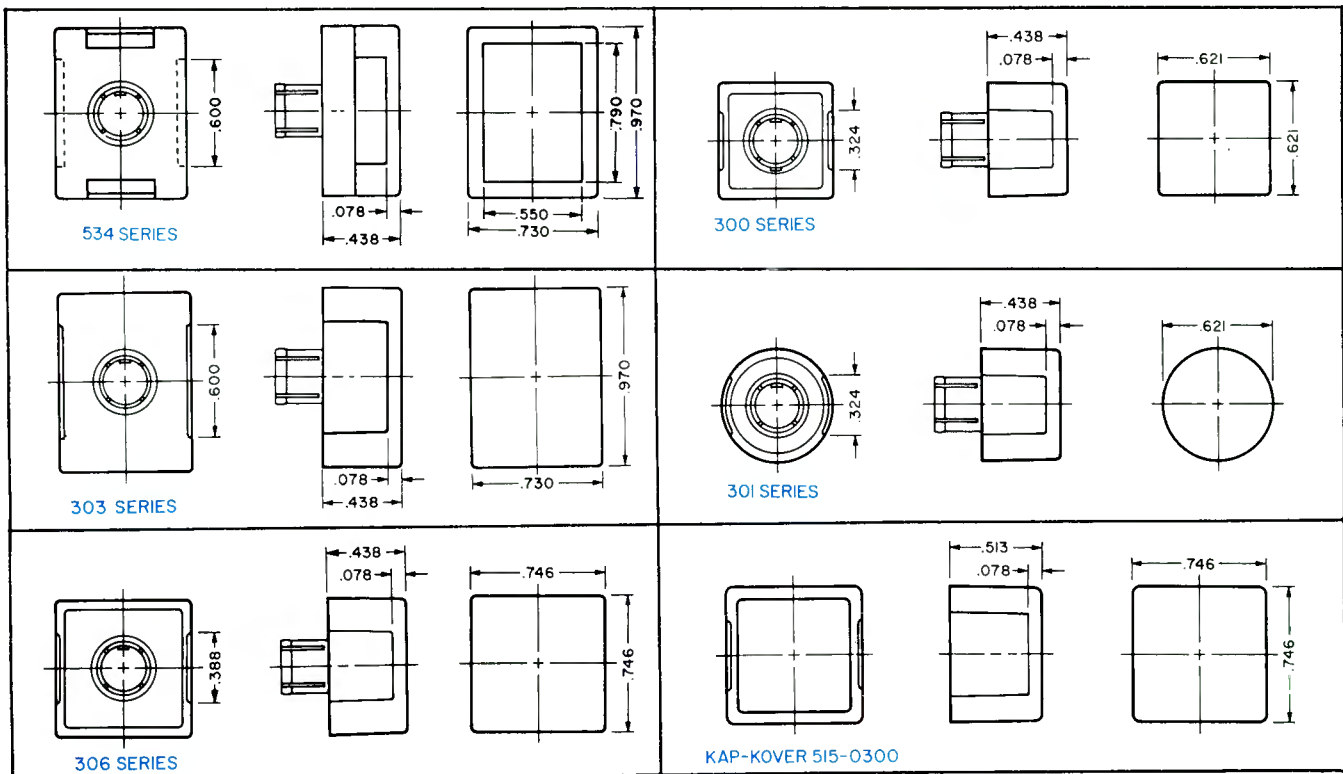



Push button cap specifications

For use with Panel Mounting Switches
& Matching Indicators only

(See additional cap selections on pages 12-13)

Rotatable push button caps permit alignment of legends and edges of square or rectangular caps after installation of the switch assembly. Keyed push button caps are mounted in a pre-determined position only.

One color push button caps are available in seven colors. Two color effects may be obtained with a choice of these seven colors for the cap face with either black, gray or white opaque sides.

Underlying colored filters can also be furnished with push button caps having solid white translucent or opaque sides and white translucent top. This would result in the complete push button cap or cap face only being visible as white when not energized and in another color when energized.

When inserting push button caps through an overlay panel for low-profile appearance, rotatable caps are recommended.

Relamping: The push button cap accommodates the lamp. To replace lamp, the cap need only be removed from the front of the panel. See Page 23 for "Positive" and "Negative" reading legend standards.

MATERIAL AND FINISHES: Cap is plastic, fitted with brass shank, white nickel plated.

PUSH BUTTON + CAP COLOR COMBINATIONS	1/2" ROUND				1/2" ROUND		1/2" SQUARE			
	FRICTION - FIT NON - ROTATABLE		FRICTION - FIT ROTATABLE		SCREW - IN		FRICTION - FIT NON - ROTATABLE		FRICTION - FIT ROTATABLE	
	NO LEGEND	WITH LEGEND ENGRAVED AND BLACK FILLED	NO LEGEND	WITH LEGEND ENGRAVED AND BLACK FILLED	NO LEGEND	WITH LEGEND ENGRAVED AND BLACK FILLED	NO LEGEND	WITH LEGEND ENGRAVED AND BLACK FILLED	NO LEGEND	WITH LEGEND ENGRAVED AND BLACK FILLED
Solid Color Translucent Face & Sides	186-1471	186-6571	183-1471	183-6571	192-1471	192-6571	184-1871	184-6371	185-1871	185-6371
Solid Color** † Transparent Face & Sides	186-1431	186-6531	183-1431	183-6531
Translucent Colored Face, Black Opaque Sides	186-5071	186-6971	183-5071	183-6971	192-5071	192-6971	184-5071	184-6971	185-5071	185-6971
Translucent Colored Face, Gray Opaque Sides	186-5171	186-7171	183-5171	183-7171	192-5171	192-7171	184-5171	184-7171	185-5171	185-7171
Translucent Colored Face, White Opaque Sides	186-5271	186-7371	183-5271	183-7371	192-5271	192-7371	184-5271	184-7371	185-5271	185-7371
Translucent White Face, Black Opaque Sides, Underlying Colored Filter	186-5061	186-6961	183-5061	183-6961	192-5061	192-6961	184-5061	184-6961	185-5061	185-6961
Translucent White Face, Gray Opaque Sides, Underlying Colored Filter	186-5161	186-7161	183-5161	183-7161	192-5161	192-7161	184-5161	184-7161	185-5161	185-7161
Translucent White Face, White Opaque Sides, Underlying Colored Filter	186-5261	186-7361	183-5261	183-7361	192-5261	192-7361	184-5261	184-7361	185-5261	185-7361
Transparent Face With Internal Diffusing Rings, White Opaque Sides	186-5291	183-5291
		ENGRAVED NEGATIVE LEGEND		ENGRAVED NEGATIVE LEGEND		ENGRAVED NEGATIVE LEGEND		ENGRAVED NEGATIVE LEGEND		ENGRAVED NEGATIVE LEGEND
Black Opaque Overlay On Translucent Colored Face, Black Opaque Sides	186-5371	183-5371	192-5371	184-5371	185-5371
Gray Opaque Overlay On Translucent Colored Face, Gray Opaque Sides	186-5471	183-5471	192-5471	184-5471	185-5471
Black Opaque Overlay On Translucent Colored Face, White Opaque Sides	186-5571	183-5571	192-5571	184-5571	185-5571
Gray Opaque Overlay On Translucent Colored Face, White Opaque Sides	186-5671	183-5671	192-5671	184-5671	185-5671

* * This series only is also available in clear colorless and is designated by -1437. + See "Lens Face Color" on facing page.

◆ Specify switch bases for use with screw-in push button caps only. See ordering information on page 6.

● Also available with fingertip grip. To specify, add suffix -008 to catalog number. Examples: 186-1471-008; 185-6371-008.

† Suitable for use with based light emitting diode.

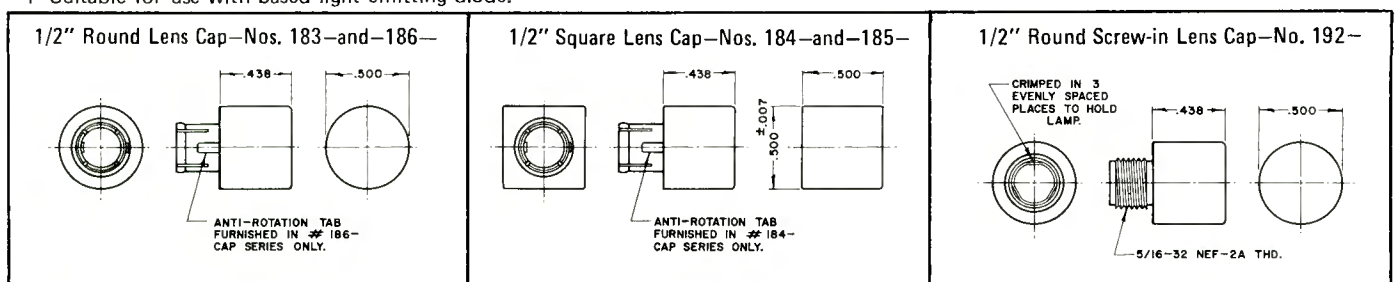

and ordering information

LENS FACE COLOR (For charts listing 1/2" and 3/4" caps):
 The last digit in the catalog number indicates that the lens or underlying filter is RED. When a color other than red is desired, change this digit to a figure from the listing below:
 Red - 1; Green - 2; Yellow (Amber) - 3; Blue - 4;
 White Translucent - 5; Light Yellow - 6; Ivory - 8.
 Example: 183-1475 (White cap face).
 185-5162 (White cap face & Green underlying filter).

THE LIGHT SOURCE

The light source is the T-1 3/4 bulb with midget flanged base - incandescent - in a range of voltages from 5 to 28V. SEE LAMP CHART ON PAGE 8.

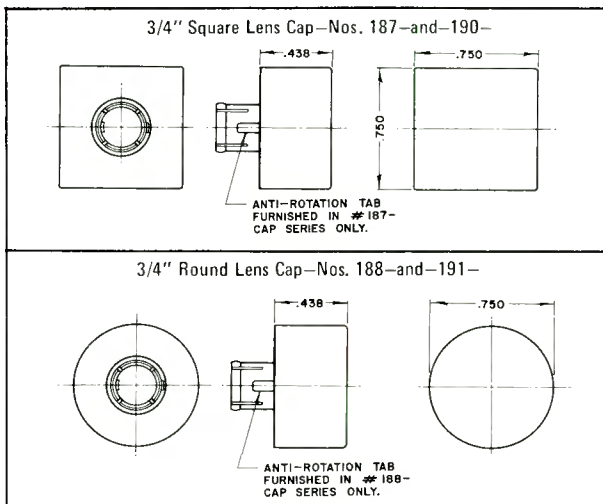

1/2" SQUARE

184 Series
 Non-Rotatable
 185 Series
 Rotatable

1/2" ROUND

186 Series
 Non-Rotatable
 183 Series
 Rotatable

3/4" SQUARE

187 Series
 Non-Rotatable
 190 Series
 Rotatable

3/4" ROUND

188 Series
 Non-Rotatable
 191 Series
 Rotatable

Typical Push Button Caps



Translucent Colored Face,
 Black Opaque Sides



Gray Opaque Overlay on
 Translucent Colored Face,
 Gray Opaque Sides

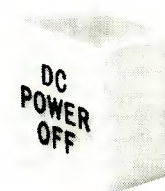

Solid Color
 Translucent Face and Sides



Black Opaque Overlay on
 Translucent Colored Face,
 Black Opaque Sides

PUSH BUTTON + CAP COLOR COMBINATIONS	3/4" ROUND				3/4" SQUARE			
	FRICTION - FIT NON - ROTATABLE		FRICTION - FIT ROTATABLE		FRICTION - FIT NON - ROTATABLE		FRICTION - FIT ROTATABLE	
	NO LEGEND	WITH LEGEND ENGRAVED AND BLACK FILLED	NO LEGEND	WITH LEGEND ENGRAVED AND BLACK FILLED	NO LEGEND	WITH LEGEND ENGRAVED AND BLACK FILLED	NO LEGEND	WITH LEGEND ENGRAVED AND BLACK FILLED
Solid Color, Translucent Face & Sides	188-1471	188-6571	191-1471	191-6571	187-1871	187-6371	190-1871	190-6371
Translucent Colored Face, Black Opaque Sides	188-5071	188-6971	191-5071	191-6971	187-5071	187-6971	190-5071	190-6971
Translucent Colored Face, Gray Opaque Sides	188-5171	188-7171	191-5171	191-7171	187-5171	187-7171	190-5171	190-7171
Translucent Colored Face, White Opaque Sides	188-5271	188-7371	191-5271	191-7371	187-5271	187-7371	190-5271	190-7371
Translucent White Face, Black Opaque Sides, Underlying Colored Filter	188-5061	188-6961	191-5061	191-6961	187-5061	187-6961	190-5061	190-6961
Translucent White Face, Gray Opaque Sides, Underlying Colored Filter	188-5161	188-7161	191-5161	191-7161	187-5161	187-7161	190-5161	190-7161
Translucent White Face, White Opaque Sides, Underlying Colored Filter	188-5261	188-7361	191-5261	191-7361	187-5261	187-7361	190-5261	190-7361
		ENGRAVED NEGATIVE LEGEND		ENGRAVED NEGATIVE LEGEND		ENGRAVED NEGATIVE LEGEND		ENGRAVED NEGATIVE LEGEND
Black Opaque Overlay On Translucent Colored Face, Black Opaque Sides	188-5371	191-5371	187-5371	190-5371
Gray Opaque Overlay On Translucent Colored Face, Gray Opaque Sides	188-5471	191-5471	187-5471	190-5471
Black Opaque Overlay On Translucent Colored Face, White Opaque Sides	188-5571	191-5571	187-5571	190-5571
Gray Opaque Overlay On Translucent Colored Face, White Opaque Sides	188-5671	191-5671	187-5671	190-5671

• Also available with fingertip grip. To specify add suffix -008 to catalog number, Example: 190-6961-008. Exception: 187-1871 Series and 190-1871 Series (with solid color, translucent face and sides): these change to 307-1871 and 306-1871 Series respectively.

+ See "Lens Face Color" above.

Dialight push button cap specifications and

For use with Panel Mounting Switches & Matching Indicators only

When inserting push button caps through an overlay panel for low-profile appearance, rotatable caps are recommended.

Fingertip grip: To specify push button cap series 179, 182 (see below) or 199 (facing page) add suffix -008 to catalog number. Examples: 182-6371-008; 199-5261-008.

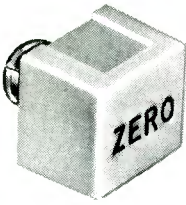
 <p>5/8" SQUARE PUSH BUTTON CAPS Non-Rotatable 304 SERIES</p>	TRANSLUCENT COLOR	WITHOUT LEGEND	WITH LEGEND ENGRAVED AND BLACK FILLED	WHITE TRANSLUCENT WITH COLORED FILTER WITHOUT LEGEND	WHITE TRANSLUCENT WITH COLORED FILTER LEGEND ENGRAVED AND BLACK FILLED
	Red	304-1871	304-6371	304-1861	304-6361
	Green	304-1872	304-6372	304-1862	304-6362
	Yellow (Amber)	304-1873	304-6373	304-1863	304-6363
	Blue	304-1874	304-6374	304-1864	304-6364
	White	304-1875	304-6375	-----	-----
	Lt. Yellow	304-1876	304-6376	-----	-----

To obtain rotatable push button cap, change the catalog number prefix to 300. Example: 300-1861.



Use of 304 Series Push Button Caps with clear colorless Kap-Kover (see dimensional drawing on facing page - Catalog No. 515-0300) permit the user to insert or replace a legend simply, quickly, on location. The Kap-Kover fits over the legend and the 304 Series push button cap ... and may be used with switches and matching indicators.

To order:

KAP-KOVER	CAT. NO.
Clear colorless	515-0300

 <p>5/8" ROUND PUSH BUTTON CAPS Non-Rotatable 305 SERIES</p>	TRANSLUCENT COLOR	WITHOUT LEGEND	WITH LEGEND ENGRAVED AND BLACK FILLED	WHITE TRANSLUCENT WITH COLORED FILTER WITHOUT LEGEND	WHITE TRANSLUCENT WITH COLORED FILTER LEGEND ENGRAVED AND BLACK FILLED
	Red	305-1471	305-6571	305-1461	305-6561
	Green	305-1472	305-6572	305-1462	305-6562
	Yellow (Amber)	305-1473	305-6573	305-1463	305-6563
	Blue	305-1474	305-6574	305-1464	305-6564
	White	305-1475	305-6575	-----	-----
	Lt. Yellow	305-1476	305-6576	-----	-----

To obtain rotatable push button cap, change the catalog number prefix to 301. Example: 301-6573.

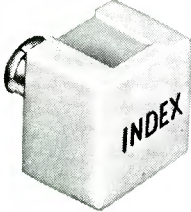
 <p>3/4" SQUARE PUSH BUTTON CAPS Non-Rotatable 307 SERIES</p>	TRANSLUCENT COLOR	WITHOUT LEGEND	WITH LEGEND ENGRAVED AND BLACK FILLED	WHITE TRANSLUCENT WITH COLORED FILTER WITHOUT LEGEND	WHITE TRANSLUCENT WITH COLORED FILTER LEGEND ENGRAVED AND BLACK FILLED
	Red	307-1871	307-6371	307-1861	307-6361
	Green	307-1872	307-6372	307-1862	307-6362
	Yellow (Amber)	307-1873	307-6373	307-1863	307-6363
	Blue	307-1874	307-6374	307-1864	307-6364
	White	307-1875	307-6375	-----	-----
	Lt. Yellow	307-1876	307-6376	-----	-----

To obtain rotatable push button caps, change the catalog number prefix to 306. Example: 306-6374.

 <p>1/2" X 3/4" PUSH BUTTON CAPS Non-Rotatable 182 SERIES</p>	TRANSLUCENT COLOR	WITHOUT LEGEND	WITH LEGEND ENGRAVED AND BLACK FILLED	WHITE TRANSLUCENT WITH COLORED FILTER WITHOUT LEGEND	WHITE TRANSLUCENT WITH COLORED FILTER LEGEND ENGRAVED AND BLACK FILLED
	Red	182-3471	182-6371	182-3461	182-6361
	Green	182-3472	182-6372	182-3462	182-6362
	Yellow (Amber)	182-3473	182-6373	182-3463	182-6363
	Blue	182-3474	182-6374	182-3464	182-6364
	White	182-3475	182-6375	-----	-----
	Lt. Yellow	182-3476	182-6376	-----	-----

To obtain rotatable push button cap, change the catalog number prefix to 179. Example: 179-6372.

+ Also with fingertip grip. To specify add suffix -008. Examples: 179-6375-008; 182-3471-008

* May also be used with Snap-in Mounting Switches and Matching Indicators.

LEGEND STANDARDS: SEE PAGE 23

Ordering information



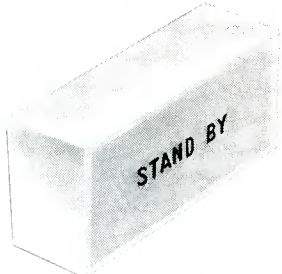

3/4" X 1 1/2" + PUSH BUTTON CAPS Non-Rotatable	PUSH BUTTON CAP COLOR	NO LEGEND	WITH LEGEND ENGRAVED AND BLACK FILLED
	White Translucent Face, White Opaque Sides	199-5275	199-7375

3/4" X 1 1/2" + PUSH BUTTON CAPS Non-Rotatable With Underlying Colored Filter	WITH COLORED FILTER	WHITE TRANSLUCENT FACE & WHITE OPAQUE SIDES W/COLORED FILTER NO LEGEND	WHITE TRANSLUCENT FACE & WHITE OPAQUE SIDES W/COLORED FILTER LEGEND ENGRAVED AND BLACK FILLED
	Red	199-5261	199-7361
	Green	199-5262	199-7362
	Yellow (Amber)	199-5263	199-7363
	Blue	199-5264	199-7364

Caps have white opaque sides only.
+ Also with fingertip grip. To specify add suffix **-008**. Example: 199-5275-008.

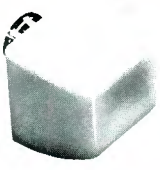

TRANSLUCENT CAP COLORS	W/ANTI ROTATION TAB	W/O ANTI ROTATION TAB
Red	309-1871	308-1871
Green	309-1872	308-1872
Amber	309-1873	308-1873
Blue	309-1874	308-1874
White	309-1875	308-1875
Lt. Yellow	309-1876	308-1876
Ivory	309-1878	308-1878

308 SERIES
309 SERIES

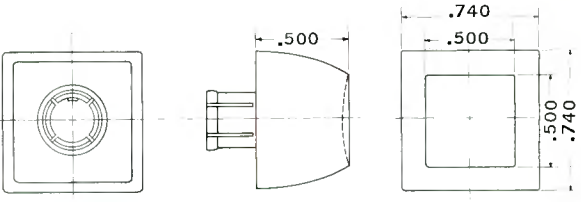

308 SERIES
309 SERIES

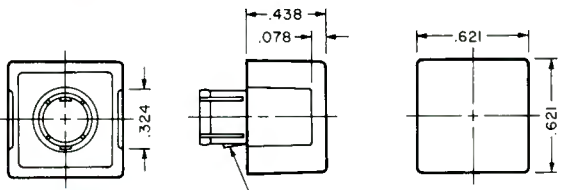

304 SERIES

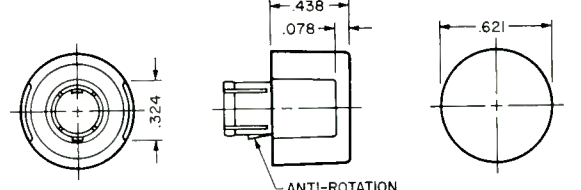

305 SERIES

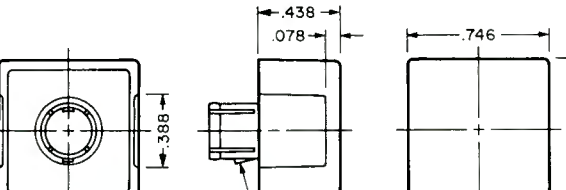

307 SERIES

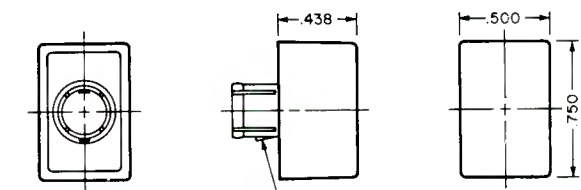

182 SERIES

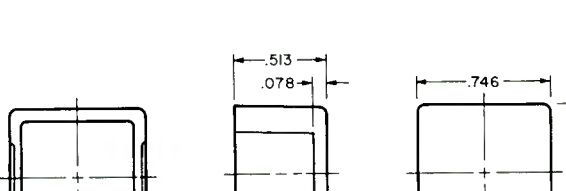

KAP-KOVER 515-0300

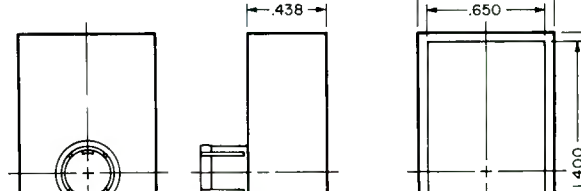

199 SERIES

Matching indicator specifications and

Snap-in Mounting Type

Materials and Finishes

- **Mounting Bushing (base assembly):** Aluminum, clear anodize finish.
- **Terminals:** Brass, hot-tinned, with elongated slots.

- **Bezel:** Heat resistant plastic.
- **Clip:** Stainless steel.
- **Spanner Ring:** Aluminum, clear anodize finish.

FIG. NO.	CAP SELECTION†
1	300 SERIES
2	301 SERIES
3	303 & 534 SERIES
4	303 & 534 SERIES
5	300 SERIES with KAP-KOVER or 306 SERIES ONLY

† See data on Pages 8-9.

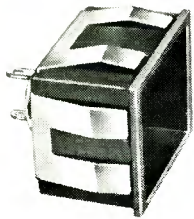

Indicator Base

MATCHING INDICATOR BASE ASSEMBLIES					
ACCOMMODATE THE FOLLOWING SERIES PUSH BUTTON CAPS:					
BEZEL COLOR	300 SERIES 5/8" SQUARE FIG. 1	301 SERIES 5/8" ROUND FIG. 2	303 and 534 SERIES 3/4" x 1"		300 SERIES W/ KAP-KOVER* - or 306 SERIES 3/4" SQUARE FIG. 5
			w/o BARRIER FIG. 3	w/BARRIER FIG. 4	
Black	533-0601	533-0701	533-0901	533-1001	533-1101
Gray	533-0602	533-0702	533-0902	533-1002	533-1102
Dark Gray	533-0603	533-0703	533-0903	533-1003	533-1103
White	533-0604	533-0704	533-0904	533-1004	533-1104

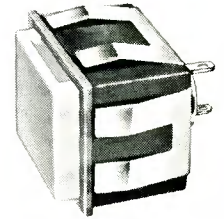

Complete matching indicator

MATCHING INDICATOR BASES

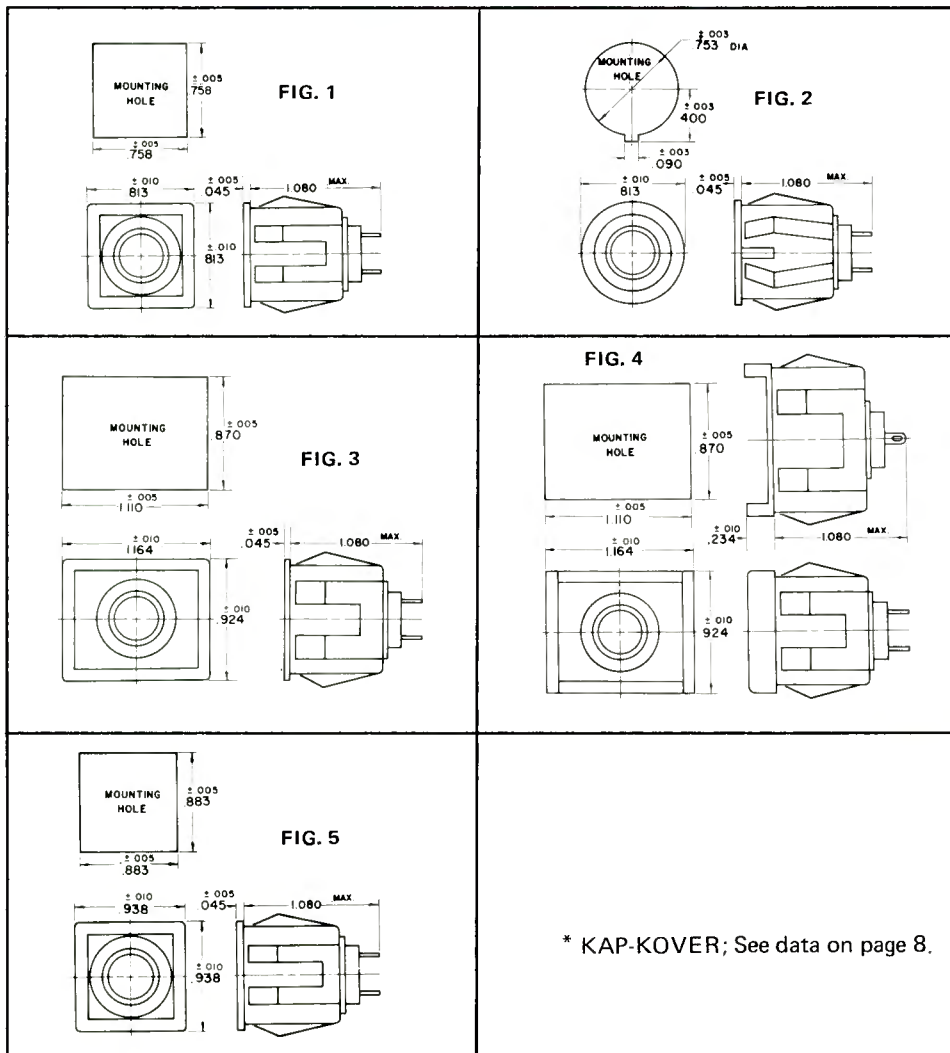

* KAP-KOVER; See data on page 8.

Panel Mounting Type

MATCHING INDICATOR BASES

Indicator light bases are of two types: With fixed flange for front mounting in 15/32" clearance hole; or with threaded knurled flange and hex nut at the rear which facilitates mounting from either front or rear in 1/2" clearance hole. The mounting hole for the latter should be notched for anti-rotation.

Matching indicator bases (and switch bases described on pages 6-7) may be mounted on a sub-panel and the caps inserted through an overlay panel for **low-profile appearance**.

Matching indicator and push button bases accommodate interchangeable friction-fit push button caps. This permits front-of-panel configuration with **identical or complementary appearance**. See cap data and ordering information on pages 10-13.

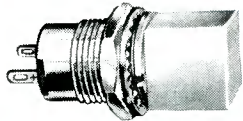

Complete matching indicator

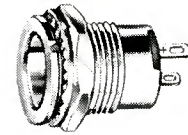

Front Mounting in 15/32" Clearance Hole
183-9730-14-602

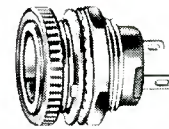

Front or Rear Mounting in 1/2" Clearance Hole
183-9830-14-604

MATCHING INDICATOR BASES

TERMINALS	FRONT MOUNTING IN 15/32" CLEARANCE HOLE	FRONT OR REAR MOUNTING IN 1/2" CLEARANCE HOLE
Solder blade	183-9730-14-602	183-9830-14-604
Printed circuit	—	183-8130-14-604

Optional Finish: The complete bushing for the 15/32" unit or the knurled flange ring on the 1/2" assembly may be obtained with **optional black anodize finish**. To specify, change the "6" to "5" in the code number suffix. Examples: 183-9730-14-502; 183-9830-14-504.

MATERIALS AND FINISHES

- **Mounting Bushing** (base assembly): aluminum, clear anodize finish. Optional (15/32" only) — black anodize finish.
- **Hardware: For 1/2" Mounting:** Round Knurled Flange Nut — aluminum, clear anodized or (optional) black anodized . . . Hex Nut — aluminum, clear anodized . . . Lock Ring — aluminum, chromate finish . . . Lockwasher — phosphor bronze, white nickel plated.
- **For 15/32" Mounting:** Hex Nut and Lockwasher — steel, cadmium plated, with chromate finish.
- **Terminals:** Solder blade -brass, hot tin dip.
Printed Circuit -brass, hot tin dip.

MOUNTING HOLE

183-9830-14-604		183-9730-14-602
Panel Mounting Hole	Alternate Panel Mounting Hole	Panel Mounting Hole

WRENCH: See data on page 7.

Front or Rear Mounting in 1/2" Clearance Hole

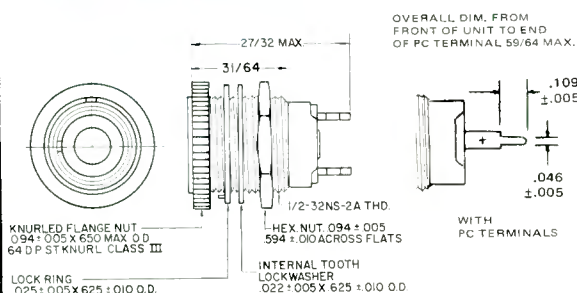

Front Mounting in 15/32" Clearance Hole

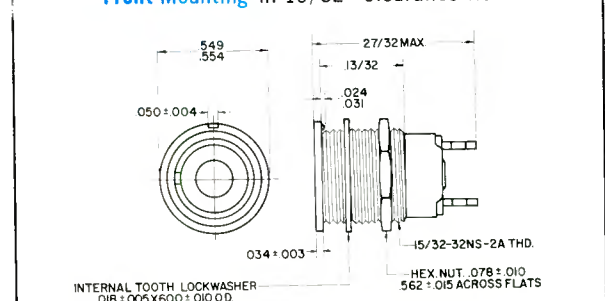

D.P.D.T. snap-action switch specifications and



Momentary or alternate action

available with choice of panel or snap-in mounting feature.

FEATURES

- **Circuit:** Double Pole, Double Throw (D.P.D.T.).
- **Contact Parts:** Fine Silver.
- **Insulated:** The switch circuit is insulated from, and independent of, the lamp circuit.
- **Completely Enclosed:** The switch mechanism and contact parts are completely enclosed.
- **Operating Force:** Momentary — 15 oz. \pm 3 oz.
Alternate — 32 oz. \pm 8 oz.
- **Button Travel:** Momentary — .070
Alternate — .106
- **Life:** Momentary — 100,000 operations at rated load.
Alternate — 25,000 operations at rated load.

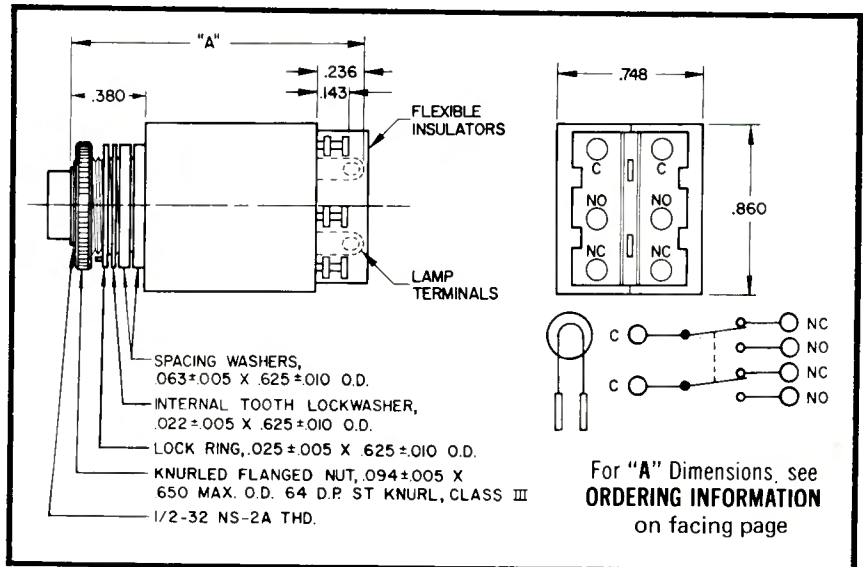

This switch series accommodates a T-1 3/4 bulb with midjet flanged base—incandescent, in a range of voltages to 28.

Panel mounting switches may be mounted on a sub-panel and the cap inserted through an overlay panel for low profile appearance.

Snap-in mounting switches may be mounted singly in panel cutouts or matrix mounted in groups of 2-6 units (see "Matrix Mounting Dimensions" on facing page).

PUSH BUTTON CAP SELECTION

PANEL MOUNTING		SNAP-IN MOUNTING	
Size/Shape	Series Nos. +	Size/Shape	Series Nos. =
1/2" x 3/4" Rectangle	179 & 182	With rectangular bezel: 3/4" x 1" rectangle	303 & 534
3/4" x 1-1/2" Rectangle	199		
1/2" Square	184 & 185	With square bezel: 5/8" square w/Kap-Kover	300 w/515-0300
1/2" Round	183 & 186		
5/8" Square	300 & 304	With square bezel: 3/4" square	306
5/8" Round	301 & 305		
3/4" Square	187, 190, 306 & 307		
3/4" Round	188, 191		
Keyboard*	308 & 309		
Kap-Kover	515-0300		

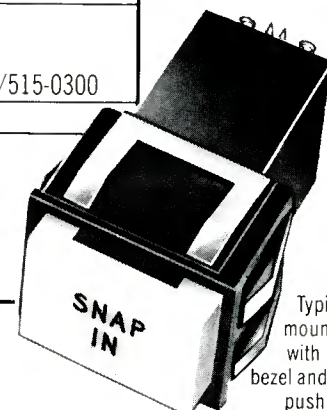

Typical snap-in mounting switch with rectangular bezel and 303 series push button cap

+ Refer to pages 10-13 for data and dimensional drawings

= Refer to pages 8-9 for data and dimensional drawings

* Refer to page 13 for data and dimensional drawings

NOTE: See page 23 for LEGEND STANDARDS

Dialight push button switch specifications and

The 913 Series switch has light action and requires short travel. The switch is available illuminated with NEON or LED light source, or non-illuminated.

913 SERIES



913-1436-1631-525
WITH LAMP



913-1227-1571-525
NO LAMP

Non-replaceable Neon lamp - mounts from rear in 3/8" clearance hole

Switch Ratings.....	S.P.S.T. Double break, N.O., N.C. or Two Circuits (one N.O., one N.C.)
	0.1 amp, 125V AC
	0.1 amp, 30V DC (resistive)
Operating Force.....	10 ozs. (typical)
Button travel.....	5/64" (typical)
Life.....	1,000,000 operations (typical)
Contact resistance.....	50 milliohms max. initial

The 913 series circuit is completed by a moving, flexible, bridging member meeting two stationary contacts. All contact parts are gold plated, assuring excellent contact with light pressure.

Illumination of the transparent push button is obtained from a T-2 Neon Lamp. The Neon lamp may be the high brightness C2A (NE-2H) or the standard brightness A9A (NE-2E).

Lamp A9A (NE-2E) is suitable for operation on AC or DC circuits of 105-125 volts. Lamp C2A (NE-2H) is recommended for 110-125V AC circuits where the lighting level must be higher. On equal life basis, the C2A (NE-2H) lamp gives about ten times as much light as the A9A (NE-2E).

The integral resistor may or may not be included in the switch housing. If omitted, the necessary current-limiting resistor must be added externally. The following values are used internally and are recommended for external use. All values are for 110-125V circuit range.

A9A	100K - 25,000 hours
C2A	33K - 25,000 hours

SWITCH CHARACTERISTICS

- **Momentary Action:** The switch mechanism is of the "momentary" type. As long as pressure is maintained on the push button cap, the circuit change is maintained. The push action is smooth - only light pressure is required.
- **Circuits:** Single circuit, normally open or closed; two circuit, one normally open, one normally closed.
- **Contact Parts:** Gold plated.
- **Isolation:** The switch circuit is completely independent of the lamp circuit.
- **Completely enclosed:** The switch action and contact parts are completely enclosed.

MATERIALS AND FINISHES

- **Mounting Bushing** (base assembly): Aluminum, black anodize finish.
- **Hardware:** Knurled flange nut - Aluminum, black anodize finish; optional - clear anodize finish. Internal-tooth lockwasher - phosphor bronze, white nickel finish.
- **Terminals:** Solder blade - brass, gold plated (switch).
Solder blade - brass, silver plated (lamp).
- **Dielectric breakdown:** 1250V AC.

ENGRAVED and FILLED LEGENDS

(Digits, Letters or Symbols on Flat End Cylindrical Lenses)

Illuminated Switch Push Button Caps: Standard—BLACK; Optional—white, red or green can be supplied to order.

Non-Illuminated Switch Push Button Caps: Standard—Black with amber, white or yellow push button caps. WHITE with black, red, green or blue push button caps. Optional colors—red, green or blue to order.

LEGEND STANDARDS: See data on page 23

ORDERING INFORMATION

ILLUMINATED PUSH BUTTON SWITCHES

Catalog Number	Switch Form	Lamp	Resistor Value
913-1151-1631-525	NORMALLY OPEN	A9A	NONE
913-1153-1631-525	NORMALLY OPEN	A9A	100K
913-1154-1631-525	NORMALLY OPEN	C2A	NONE
913-1156-1631-525	NORMALLY OPEN	C2A	33K
913-1425-1631-525	NORMALLY CLOSED	A9A	NONE
913-1427-1631-525	NORMALLY CLOSED	A9A	100K
913-1428-1631-525	NORMALLY CLOSED	C2A	NONE
913-1430-1631-525	NORMALLY CLOSED	C2A	33K
913-1431-1631-525	TWO CIRCUIT	A9A	NONE
913-1433-1631-525	TWO CIRCUIT	A9A	100K
913-1434-1631-525	TWO CIRCUIT	C2A	NONE
913-1436-1631-525	TWO CIRCUIT	C2A	33K

NON-ILLUMINATED PUSH BUTTON SWITCHES

Catalog Number	Switch Form	Lamp	Resistor Value
913-1227-1570-525	NORMALLY OPEN	NONE	NONE
913-1442-1570-525	NORMALLY CLOSED	NONE	NONE
913-1443-1570-525	TWO CIRCUIT	NONE	NONE

PUSH BUTTON COLOR: The last digit in code block three designates push button cap color. Change this digit to obtain the desired color using the color code listings below:

Illuminated Switch Push Button Cap Colors	Non-Illuminated Switch Push Button Cap Colors
1 - red	0 - black
3 - yellow (amber)	4 - blue
5 - white (translucent)	1 - red
7 - clear (colorless)	2 - green
Example: 913-1430-1635-525	3 - amber
	5 - white
	6 - yellow
	Example: 913-1442-1574-525

HOW TO DESIGNATE THE 3 DIGIT CODE NUMBER SUFFIX (-XXX)

Finish	Panel Thickness	Terminals
5-black anodize	2-1/8"	5-soldering
6-clear anodize	3-3/16"	9-PC board

Examples: 913-1154-1631-625 (clear anodize finish);
913-1425-1631-535 (3/16" panel thickness)

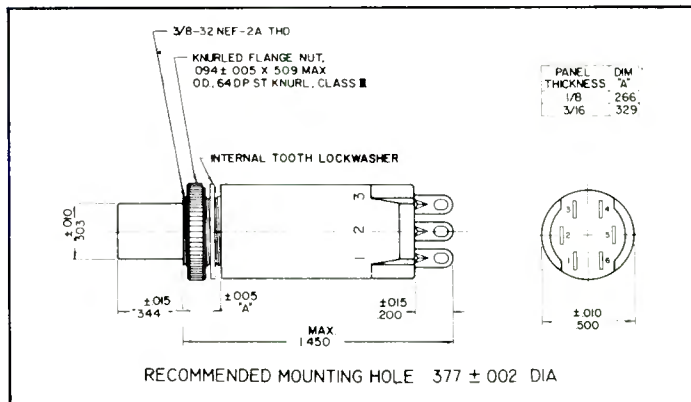

913 Series Diode-Lited Switch

- Light source - supplied with solid state Diode-Lite (LED) operating from 5V DC supply*.
- High Reliability. Where extra-long life or low power is required, the Diode-Lited switch should be considered for use.
- Miniature momentary action switch.
- The Diode-Lited series has the same Switch Characteristics, Materials & Finishes, Switch Ratings, Operating Force, Button Travel, Life and Contact Resistance as the Neon series described above.
- See dimensional drawing above.

ORDERING INFORMATION ▲

WITH RED LED	TRANSPARENT LENS COLOR	NORMALLY OPEN	NORMALLY CLOSED	TWO CIRCUIT
	Red	913-1551-1631-525	913-1552-1631-525	913-1553-1631-525
White	913-1551-1635-525	913-1552-1635-525	913-1553-1635-525	
Clear	913-1551-1637-525	913-1552-1637-525	913-1553-1637-525	

WITH GREEN LED	Green	913-1601-1632-525	913-1602-1632-525	913-1603-1632-525
	White	913-1601-1635-525	913-1602-1635-525	913-1603-1635-525
	Clear	913-1601-1637-525	913-1602-1637-525	913-1603-1637-525

WITH YELLOW LED	Yellow (Amber)	913-1604-1633-525	913-1605-1633-525	913-1606-1633-525
	White	913-1604-1635-525	913-1605-1635-525	913-1606-1635-525
	Clear	913-1604-1637-525	913-1605-1637-525	913-1606-1637-525

Note: The above catalog numbers designate switches for mounting on panels of 1/8" thickness. To obtain switches for mounting on panels of 3/16" thickness, change the "2" in the catalog number suffix to "3".

Example: 913-1551-1635-535.

▲ For PC board terminals, change last digit to 9. Example: 913-1552-1631-529.

*For DC voltages other than 5 volts, an external resistor is required. The value is determined by: $R = \frac{V_s - 5}{.015}$

Illuminated push button switch

The 922 Series switch has light action and requires short travel. This miniature incandescent switch mounts from rear in 3/8" clearance hole — has life of 1,000,000 operations (typical).

Incandescent
- mounts from rear
3/8" clearance hole

922 SERIES



922-1524-525



908-1535

Switch Ratings S.P.S.T. Double break, N.O., N.C.,
Two Circuit (one N.O., one N.C.)

0.1 amp, 125V AC

0.1 amp, 30V DC (resistive)

Operating Force10 ozs. (typical)

Button Travel5/64" (typical)

Life1,000,000 operations (typical)



Typical complete
push button switch

The 922 series circuit is completed by a moving flexible, bridging member meeting two stationary contacts. All contact parts are gold plated, assuring excellent contact with light pressure.

Illumination of the transparent push button is obtained from a midget flanged base incandescent lamp, available in a range of voltages to 28V. The lamp seats in a metal insert in the lower end of the plastic push button. It may be readily replaced by removing the push button. See chart for T-1 3/4 bulbs with midget flanged base on Page 8.

SWITCH CHARACTERISTICS

Momentary Action: The switch mechanism is of the "momentary" type. As long as pressure is maintained on the button, the circuit change is maintained. The push action is smooth - only light pressure is required.

Circuits: Single circuit, normally open or closed; two circuit, one normally open, one normally closed.

Contact Parts: Gold plated.

Isolation: The switch circuit is completely independent of the lamp circuit.

Completely enclosed: The switch action and contact parts are completely enclosed.

Illuminated push button switch

Incandescent

The 922 Series switch has light action and requires short travel. This miniature incandescent switch mounts from rear in 3/8" clearance hole — has life of 1,000,000 operations (typical).

MATERIALS & FINISHES

Mounting Bushing (base assembly): Aluminum, black anodize finish.
Hardware: Knurled flange nut - Aluminum, black anodize finish;
 optional: clear anodize finish.
Internal-tooth lockwasher - phosphor bronze, white nickel finish.
Terminals: Solder blade - brass, gold plated (switch)
 Solder blade - brass, silver plated (lamp)
Dielectric breakdown: 1250V AC
Contact Resistance: 50 Milliohms max.

ORDERING INFORMATION

Switch Forms	Catalog Numbers +▲
Normally Open	922-1524-525
Normally Closed	922-1525-525
Two Circuit	922-1526-525

This Switch series accommodates the 908 Series Cap. See chart at bottom of page.

+ To obtain knurled flange nut with optional clear anodized finish, change catalog number suffix to -625.

▲ For PC board terminals, change last digit to 9.

Example: 922-1525-529.

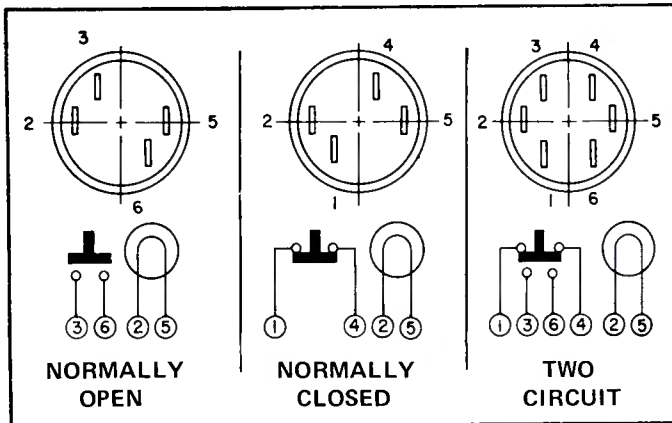
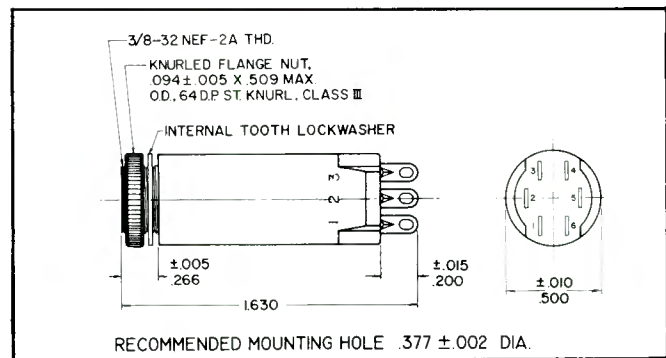



WRENCH
506-0375

WRENCH: The threaded round knurled nuts used on these switch and matching indicator light bases have a knurl of these specifications: 64 D.P. ST. KNURL, CLASS III. This wrench permits secure fastening of these products on mounting panels.

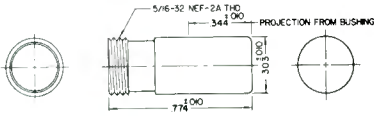
908 SERIES CAP	Transparent Lens Colors	Cylindrical Lens Fresnel Rings +	Cylindrical Lens Smooth Face & Back *
		Red	908-1631
	Green	908-1632	908-1532
	Yellow (Amber)	908-1633	908-1533
	Blue	908-1634	908-1534
	White (Translucent)	908-1635	908-1535
	Lt. Yellow	908-1636	908-1536
	Clear Colorless	908-1637	908-1537

+ Not suitable for use with legends.

* Where hot stamped or engraved legends are required, translucent lenses are recommended. To specify, change "3" in-1531- to "7"
 Example: 908-1573.

Matching indicator light

Offers choice of Incandescent or Neon light sources.

911 SERIES

Mounts from rear in
3/8" clearance hole

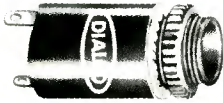

911-1112-525



911-1637



911-1112-1637-525

MATERIALS & FINISHES

- **Mounting Bushing:** Aluminum, black anodize finish.
- **Knurled flange nut:** Aluminum, black anodize finish. Optional - clear anodize finish.
- **Internal-tooth lockwasher:** Phosphor bronze, white nickel finish.
- **Terminals:** Solder blade - brass, hot tin dip.

A choice of light sources for the 911 Series Indicator light is available. The T-1 3/4 bulb with midget flanged base, incandescent, may be had in a range of low voltages from 1.35 to 28.

This series also accommodates T-2 bulb with midget flanged base, neon, designated as C7A (NE-2D) for standard brightness or C9A (NE-2J) for high brightness. Neon lamps require a resistor to limit the lamp current. As such, it is necessary that a resistor be externally mounted. See the chart with "Recommended Resistance Values".

The threaded portion of the 911 Series is in two lengths to permit mounting on panels of 1/8" or 3/16" thickness.

The lens cap is removable from front of panel for easy lamp replacement.

WRENCH: See data on page 21

LEGENDS: See data on facing page.

T-2 BULB, MIDGET FLANGED BASE-NEON RECOMMENDED RESISTANCE VALUES

FOR C7A (NE-2D) AT 105-125 VOLTS AC OR DC	
Bright Light	Long Life
62,000 ohms	100,000 ohms
FOR C9A (NE-2J) (HIGH BRIGHTNESS) AT 110-125 VOLTS AC ONLY	
Bright Light	Long Life
22,000 ohms	33,000 ohms

May be used with Neon units described on pages 18-19 and Incandescent units described on pages 20-21

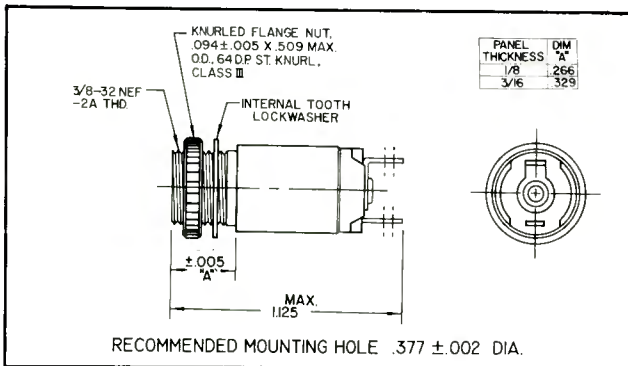

ORDERING INFORMATION

NEON OR INCANDESCENT MATCHING INDICATOR LIGHT

Base Assembly 1/8" Panel Thickness	Base Assembly 3/16" Panel Thickness
911-1112-525	911-1112-535

HOW TO DESIGNATE THE 3 DIGIT CATALOG NUMBER SUFFIX (-XXX)

FINISH	PANEL THICKNESS	TERMINAL TYPE
5-Aluminum, black anodize	2-1/8"	5-Soldering
6-Aluminum, clear anodize	3-3/16"	

The three digit suffix indicates **Finish**, **Panel Thickness** and **Terminal Type** in that order. Change the suffix to the desired features using the designations listed above. Example: 911-1112-635 (clear anodize, 3/16" panel thickness).

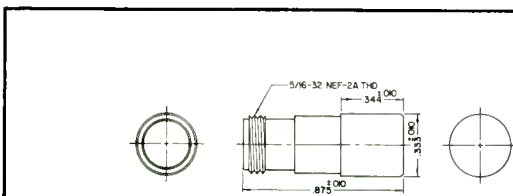

911 SERIES CAP

Transparent Lens Colors	Cylindrical Lens Fresnel Rings +	Cylindrical Lens Smooth Face & Back **
Red	911-1631	911-1531
Green *	911-1632	911-1532
Yellow (Amber)	911-1633	911-1533
Blue *	911-1634	911-1534
White (Translucent)	911-1635	911-1535
Lt. Yellow	911-1636	911-1536
Clear Colorless	911-1637	911-1537

* Green and blue lens colors are not recommended for use with Neon lamps.

** Where hot-stamped or engraved legends are required for use with incandescent lamps, translucent lenses are recommended. To specify, change "3" in -1531- to "7". Example: 911-1571.

+ Not suitable for use with legends.

Engraved and hot-stamped legends

Push button caps are available with engraved and filled legends. Lens caps (for use with matching indicators) are available with hot-stamped legends. They will be engraved and filled when requested . . . or to provide legend uniformity with push button caps on the same panel. (Note: Hot-stamping is not recommended on push button caps).

Positive Reading Legends. Hot-stamped or engraved characters provide legible, permanent identification. They appear opaque against the lighted background. Standard marking is in black for maximum contrast. Other opaque colors may be specified. Engraving and filling in white or hot-stamping in silver may be preferred on red, green and blue colors for better contrast and legibility when unlighted.

Negative Reading Legends. If it is desired to have lighted characters appear against a dark background, an opaque overlay is applied over the translucent colored face and the marking is engraved through to the luminous portion. The sides are made of opaque black or gray and only the marking is seen when the lamp is energized.

LEGEND STANDARDS. To provide uniformity of legend presentation, the size of type will be determined by the longest legend indicated in each individual order. Special legend configurations and sizes can be furnished on request.

STANDARDS

.085 LEGEND	.172 LEGEND
.109 LEGEND	.203 LEGEND
.141 LEGEND	.266 LEGEND

ABCDEFGHIJKLMNOPQRSTUVWXYZ1234567890

ENGRAVED & HOT-STAMPED LEGEND STANDARDS

PUSH BUTTON CAP SERIES	CHARACTER HEIGHT											
	.085		.109		.141		.172		.203		.266	
	MAX. LINES	MAX. CHAR. LINE	MAX. LINES	MAX. CHAR. LINE	MAX. LINES	MAX. CHAR. LINE	MAX. LINES	MAX. CHAR. LINE	MAX. LINES	MAX. CHAR. LINE	MAX. LINES	MAX. CHAR. LINE
179	3	8	2	6	2	5	1	4	1	3	1	2
182	3	8	2	6	2	5	1	4	1	3	1	2
183	2	3	1	3	1	2	1	1	1	1	--	--
184	3	4	2	3	1	3	1	2	1	2	1	1
185	3	4	2	3	1	3	1	2	1	2	1	1
186	2	3	1	3	1	2	1	1	1	1	--	--
187	4	7	3	6	2	4	2	3	2	3	1	2
188	3	5	2	5	2	3	1	3	1	2	1	1
190	4	7	3	6	2	4	2	3	2	3	1	2
191	3	5	2	5	2	3	1	3	1	2	1	1
192	2	3	1	3	1	2	1	1	1	1	--	--
199	4	14	3	12	2	9	2	8	2	7	1	5
300	4	6	3	5	2	4	2	3	1	2	1	2
301	3	4	2	4	2	3	1	3	1	2	1	1
303	4	11	4	9	3	7	2	5	2	4	1	3
304	4	6	3	5	2	4	2	3	1	2	1	2
305	3	4	2	4	2	3	1	3	1	2	1	1
306	4	7	3	6	2	4	2	3	2	3	1	2
307	4	7	3	6	2	4	2	3	2	3	1	2
534	4	10	3	8	2	6	2	5	1	4	1	2
911	1	3	1	2	--	--	1	1	--	--	--	--
913	1	3	1	2	--	--	1	1	--	--	--	--
922	1	3	1	2	--	--	1	1	--	--	--	--

DIALIGHT

A NORTH AMERICAN PHILIPS COMPANY
203 HARRISON PLACE BROOKLYN, N.Y. 11237
212-497-7600

CURRENT DIALCO LITERATURE

Indicator Lights

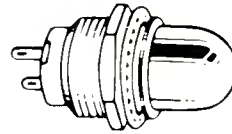

- ▲ Indicator Light Selector Guide
 - ▲ Gives general data for all indicator light catalogs listed below SG730
- ▲ Sub-Sub-Miniature Indicator Lights L-168
- ▲ Sub-Miniature Indicator Lights
 - ▲ One Terminal (For Grounded Circuits) L-157
 - ▲ Edge Lighting for Plastic Plates L-158
 - ▲ Two Terminals, Fully Insulated L-178
- ▲ Ultra-Miniature Indicator Lights UM-1200
- ▲ Miniature & Large Indicator Lights L-161
- ▲ Twin Lamp Placard Lights L-170
- ▲ Heavy Duty Oil-Tight Indicator Lights L-200
- ▲ Press-to-Test Indicator Lights L-201
- ▲ Flashing Indicator Light L-211
- ▲ A Cross Reference of DIALIGHT Catalog numbers to Military Type Designations and MS Drawings CR-680

Readouts

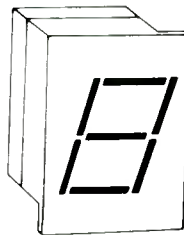

- ▲ Readout Product Selector Guide SG732

Switches

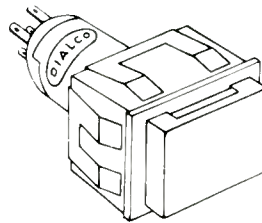

- ▲ Solid State Switch SW6110

LED Displays



- ▲ LED Product Selector Guide
 - ▲ LEDs, Indicators, Readouts, Switches SG731

Send for your copies of these catalogs



