

# NATIONAL GEOGRAPHIC

SEPTEMBER - 1939

**RADIO  
HORIZONS  
ANEW**

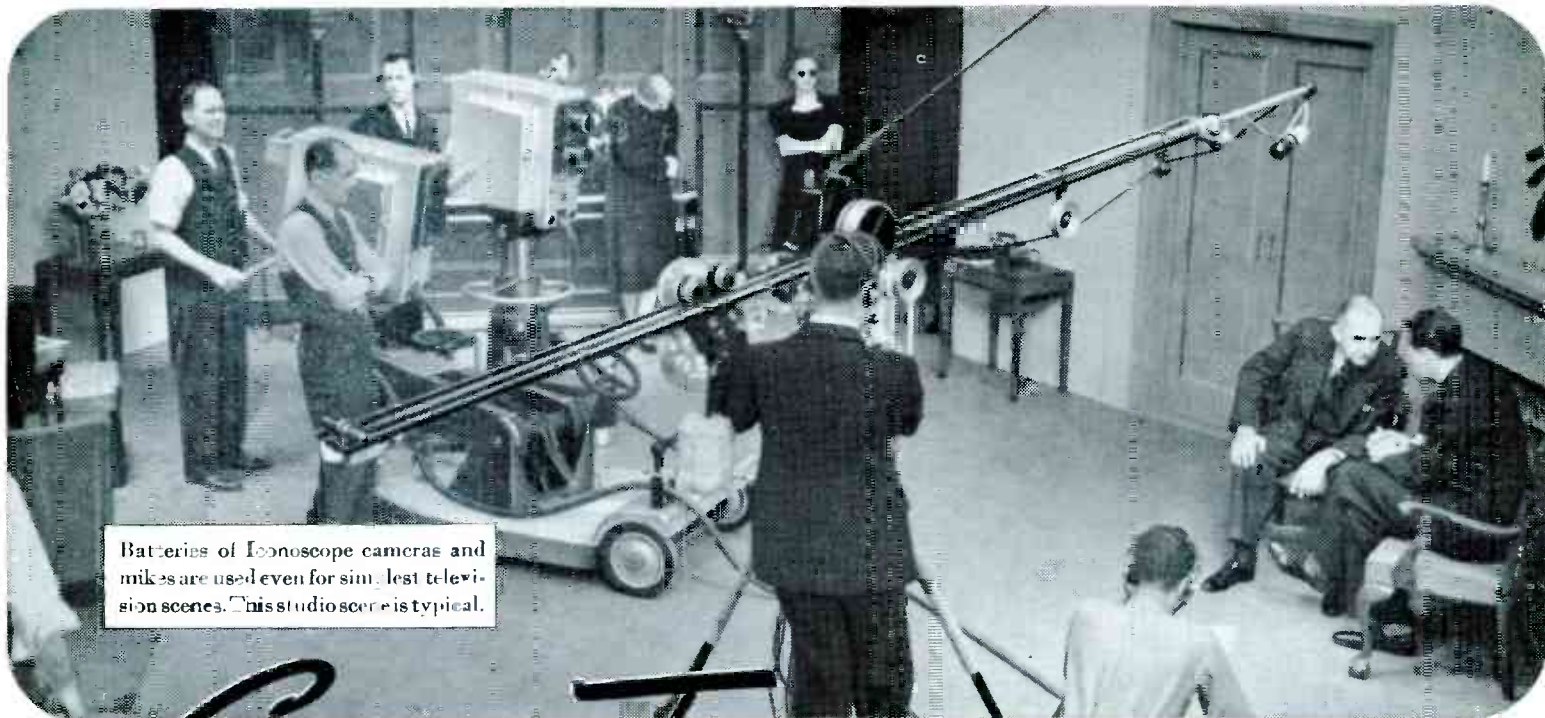



Batteries of Eonoscope cameras and mikes are used even for simplest television scenes. This studio scene is typical.

# Curtain Time

FOR A NEW AGE

OF ENTERTAINMENT



NBC Mobile Television Unit for outside pick-ups—The equipment is carried in two 10-ton trucks.

Programs by NBC to match the progress of Television

While RCA has concentrated on the technical aspects of television, NBC has studied another phase, the programming of television.

To produce television programs calls for intricate techniques. Practices are unique, and differ from those of radio, the stage or the movies. Progress has had to be largely by the trial and error method. NBC has devoted great effort, much time and a large outlay in money to the development of programming.

NBC pioneered many of the program forms which are today accepted standards of radio broadcasting. The same spirited leadership will characterize the further activities of the National Broadcasting Company in the new art of television.



This miniature model of a small city being built in NBC studios, will appear full-size when televised.



RCA Building at New York World's Fair. Visitors will see all the services of RCA including television.

**NATIONAL  
BROADCASTING  
COMPANY**

THE WORLD'S GREATEST BROADCASTING SYSTEM

A Radio Corporation of America Service

**ALL YOU'VE  
EVER ASKED FOR**  
*in a sound recorder*  
**—YOU'LL FIND in**  
*the* **NEW PRESTO  
MODEL Y**



*Write for booklet giving  
complete technical data.*

**H**ERE is the ideal sound recorder for out-of-the-studio recording. The lightest 16" recorder ever built. Weighs only 44 lbs, yet it outperforms many elaborate studio installations. Equipped with the Presto 1-B high fidelity cutting head, it records uniformly a frequency range of 50 to 6500 cycles. The exclusive Presto rubber-tired turntable, driven directly by the motor pulley, eliminates idler wheels, assures steady, vibrationless operation. Instantaneous speed change 78 to 33 1/3 RPM. Instantaneous change from outside-in to inside-out cutting. Provision for spiralling and for making eccentric trip groove at center of record. Turntable sold separately or in combination with amplifier-loudspeaker unit at the lowest price ever quoted by Presto on a 16" recorder.

**PRESTO RECORDING CORPORATION**  
242 West 55th Street, New York, N. Y.

## *A Message of Thanks to NBC Engineers*

On this occasion of our third anniversary, we are taking the opportunity to offer our sincere thanks to our friends at NBC for their valued patronage. We are particularly grateful for the cordial reception you gave our new radio supply house at 68 West 45th Street. This store will continue to offer the complete solution to all your radio requirements, including top-notch values in ham equipment, broadcast receivers and records.

Our policy as radio specialists, to carry only radio products and to direct our efforts solely in the radio field, will be maintained.

## **TERMINAL RADIO CORP.**

68 WEST 45TH STREET (near Radio City)  
80 CORTLANDT STREET, NEW YORK CITY

Phone: VAnDerbilt 6-5050



Allied "Clear-Cut" blanks are manufactured under a unique, individual process, which insures absolute flatness of surface. For this, and other reasons, ALLIED blanks are the standard of the industry and are used by many of the major broadcast stations and recording studios throughout the world. Sizes: 16", 12", 10", 8". Also Master Blanks for processing purposes. Sizes 17 1/4", 13 1/2".

Send today for our new 1939 Catalog describing the complete Allied line.

**ALLIED RECORDING PRODUCTS CO.**  
126 W. 46th STREET NEW YORK, N. Y.

Cable: ALLRECORD



## WE HAVE CROSSED THE THRESHOLD OF TOMORROW

Twenty years of public service! In that time, we have sounded almost every existing phase of the communications field. In that time, we have seen our satisfied-customer-list expand to number discriminating buyers in every country of the world.

As we have grown, so too have grown the demands of those we serve. Industry: for new and better materials. Individuals: for finer instruments of reception. As our outlook broadened and plans to meet the new demands took shape, it was apparent that a name was needed to reflect the forward-looking spirit of this company.

And so, today, Wholesale Radio Service Company becomes

### **Radio Wire Television Inc.**

There is significance in that combination of words which can be revealed only as we move out from the Threshold of Tomorrow, into the future of Communications. Result of long deliberation, here is why the name was chosen, word for word.

**RADIO:** With radio broadcasting this company has steadily expanded. It was, and is, the backbone of our business. For in spite of today's radio magic, much still remains to be done. Naturally then, radio broadcasting will continue to engage our interests.

**WIRE:** We believe the new technique of broadcasting by wire will one day encompass the transmission of both sight and sound. Every current technological development points toward this end.

**TELEVISION:** With this art a boundless field of human relations has been opened. Whether Tomorrow's televised programs be received by radio or wire, it is our aim to offer the finest services available anywhere.

Our new name thus embodies all of those important factors which in the very nature of things must hence-forward comprise our business. Already several associate enterprises in control of important patents relating to the communications field have been merged with this company.

Conscious of our great responsibility, plans are even now underway to expand the number of Radio Wire Television Inc. retail outlets. This step will place local branches at the service of all interested in finer entertainment, better products and lower costs. Long ago, we established a STANDARD OF SERVICE. To keep your confidence in us, we pledge ourselves to surpass that Standard in the future.

### **Radio Wire Television Inc.**

formerly WHOLESALE RADIO SERVICE CO., Inc.

NEW YORK • CHICAGO • ATLANTA  
BOSTON • NEWARK • BRONX, N. Y. • JAMAICA, L. I.

Radio Wire Television Inc., is licensed by arrangement with Electrical Research Products Inc., under patents of Western Electric Company, Bell Telephone Laboratories, Inc., and American Tel. & Tel. Co.

## For those who Demand PRECISION



## Skyrider 23

THE SX-23 is a truly fine example of outstanding communications engineering. It offers compensated frequency stability, eliminating drift and giving unusual reset accuracy, resulting in a station always appearing in the same spot on the dial (within a fraction of 1%.)

The controls are RF gain, Pitch control, Tone control, Selectivity switch, A.N.L. switch, Band switch, Send-receive switch, Audio gain, Crystal phasing, Main tuning and Phone jack. Eleven tubes. The cabinet is 19" long, 9 1/4" high, 12 1/2" deep. Built for 110 volt AC operation but will give 110 v. AC operation from 6 volts DC by using a 310 Electronic Converter.

### FEATURES

- ★ Entirely new bandswitch arrangement—8 positions. Bands 1-2-3-4 cover 545 kc to 44 m. continuously. Bands 5-6-7-8 are preset bandspread for the amateur 10, 20, 40 and 80 meter bands.
  - ★ A six-step wide range variable selectivity circuit gives easy control from needle sharp CW crystal to broad high-fidelity, with automatic switching of the AVC to suit the selectivity.
  - ★ An improved Dickert noise limiter that is not a sensitivity reducer but which actually cuts down ignition interference without affecting the modulated carrier level.
  - ★ Frequency stability never before achieved in a commercial receiver both from temperature-humidity effects and from line voltage variations.
  - ★ "Venetian Blind" Dial. Band indicator and S-DB meter.
  - ★ Completely shielded crystal and phasing control—permeability tuned coil—with a separate shield compartment for the crystal.
- Available from your parts jobber, complete with tubes and crystal, for \$115.50. Can be purchased on factory-sponsored time payment plan, little as \$23.10 down. Balance can be paid over a 6, 9 or 12 month period.

the hallicrafters inc.  
CHICAGO, U. S. A.

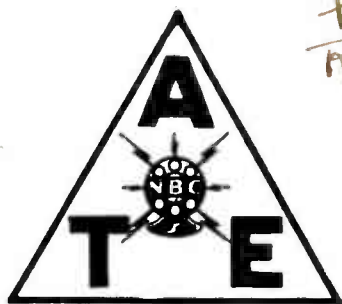

Fay Gehres  
RR # 5 Evansville Ind

WBZ - WFAA - WCOA

# JOURNAL



VOLUME 6 ISSUE 9

SEPTEMBER 1939

## RADIO LANDMARK

by JESSIE DURKEE

Station MCC/MSW—are those calls familiar to you? They were the calls of the first high-powered transmitter used in commercial service in the United States and its associated 600 meter unit.

Located at South Wellfleet, Massachusetts on the ocean side of Cape Cod, the station was built about 1902 by the American Marconi Company, put into commercial service soon after, taken over by the Navy in 1917, and dismantled at the close of the War, being superseded by WCC at Chatham.

All that remains of MCC/MSW today are the concrete bases of the inner towers, building foundations, rotting timber and metal parts from one tower, and innumerable bricks, scraps of



One of the last bases about to take its 100 foot dive into the sea. Marconi ebonite, copper ground plate, and broken glass. Tourists, on the main route from Chatham to Provincetown, their curiosity aroused by the sign "Wireless Road" have long since removed everything of interest to them.

Marconi, himself, superintended the building of the station on the 100' sand cliff at South Wellfleet. The house in which he lived for four days while the masts were being erected was, and still is, the summer home of a Boston family. Today it is known as "The Marconi House" and visitors are proudly shown the tower bedroom, commanding a wide sweep of ocean and sand dune, where the famous man slept.

The first masts could not withstand the severe winds and the shifting sands of that coast and blew down within three weeks. Then steel-reinforced wooden towers, mounted on concrete bases and held by guys anchored in concrete, were erected. There were four of these towers, 270' high, supporting a flat-topped antenna.

MCC and its sister high-powered station in Poldhu, England

were established by the Marconi Companies in the hope of putting press and messages on board ships from either side of the ocean, thereby assuring at least one-way communication with large ships any place in the North Atlantic. There was a rate of fifty cents per word for messages to ships more than 250 miles east of Nantucket.

During the early days of the stations this hope was not completely realized. The range of MCC varied considerably and it was exceptional for a ship 1500 miles away to acknowledge receipt of the broadcast. In later years the station was well heard almost completely across the ocean—approximately 95% of all messages transmitted were received satisfactorily.

The MCC transmitter, rated at some 35 KW, consisted of a generator driven by twin kerosene engines, a non-synchronous rotary spark gap, and a flock of large condensers made of glass plates and tinfoil immersed in oil.

Instead of breaking the primary current, the high voltage secondary current was broken by a huge magnetic key with two large contacts, one on either end, and a fan was used to extinguish the arc every time the key opened to keep more or less of a steady load on engine and generator. The spark on a still night could be heard as far as three miles away, and the operators worked in a soundproof room with glass windows so they could observe the spark without being subject to the deafening crashes it produced. There was an antenna current of approximately 25 amperes.

This high-powered transmitter went on the air at 9 P.M., sending at a speed of 15 to 20 words per minute, repeating three or four times, and taking sometimes as many as six hours to complete its schedule. The program was sent by means of an automatic transmitter using a perforated tape.

MSW was a 2 KW 600 meter transmitter and receiver used for direct communication with ships approaching and leaving Boston and New York. While its usual range at first was about 100 miles in daylight, as receivers progressed through the various stages from decoherers, magnetic detectors, and crystals to "valves," the range correspondingly increased.

When the station was established the outer masts were fully 160' from the edge of the bank; by the beginning of the War this distance had decreased to some 100'; today the outer towers have gone into the sea below, and the bases of the inner ones hang precariously at the edge. Such is the rate of erosion that in another five years little or nothing will be left of this historic landmark.

The people of South Wellfleet have for several years been endeavoring to arrange for a suitable lasting memorial to the famous old station and its staff. The land back from the bank where MCC/MSW once stood is privately owned but the owner has agreed that at his death the property will be sold to the town to be made into a spot of historical interest.

This fall the Italian Society of Massachusetts is erecting a bronze tablet on the dunes near the site, in honor of Marconi.

## Scientific Expedition to be Reported by Jon Larson

Through special arrangements Jon Larson, NBC Field Engineer, will accompany the forthcoming National Geographic Society-University of Virginia expedition to the South Pacific Islands. Larson with special radio equipment will accompany the party headed by Professor Wilbur A. Nelson, geologist of the University of Virginia. Larson will act as a one man broadcasting staff, arranging, directing and announcing the programs in addition to handling the controls. The radio call letters will be NRDH.

The expedition is expected to sail from San Francisco on September 19 aboard the U.S. Coast Guard cutter Hamilton, a 328 foot vessel under the command of Captain Stephen Stafford Yeandle. It carries a crew of 110 in addition to the 18 members of the party, including Larson, and will be their home for the next nine months to a year.

The scientists of the expedition are in search of answers to some fundamental questions about the Pacific, greatest of the earth's oceans—how old it is, how the vast basin originated, what changes are occurring beneath its waters and the part played in those transformations by volcanoes, earthquakes and gradual deposits of sediment.

Magnetism and magnetic changes also will be studied and the positions of many small islands that dot the South Seas within a 5,000 mile radius of Honolulu will be more accurately charted than ever before.

Among the scores of islands on which bases will be set up are Pitcairn, Tahiti, Samoa and Easter. The former is the home of the descendants of the famed mutineers of the H.M.S. Bounty.

Larson joined the National Broadcasting Company in 1930. He was born in New York City on June 19, 1905, of Swedish parentage. In his youth he became interested in radio and built his own amateur station. After graduation at Smithtown High School, on Long Island, he joined the engineering staff of WCAP, at Asbury Park, which he left a year later to join the Overseas Radio Telephone division of the A.T. & T.

While there he took a course in transmission and then went to the Chicago headquarters of Universal Wireless Communications. Came the crash of '29 and the backers of the company were forced to retrench and Larson was a casualty.

Shortly afterward he joined the NBC Central Division and has been with the company ever since. He attended the University of Chicago, the School of Finance of Central College and the John Manley Phelps School of speech while in Chicago.

During the past nine years Larson has manipulated the controls on all types of special events broadcasts carried by NBC, ranging from sports to national conventions. He helped install radio equipment for Settle-Fordney stratosphere balloon ascension in 1933 and was commended for radio work during the Ohio River Valley floods of 1937.

Larson is married and has one child, Carolyn Louise, aged three-and-a-half. The couple live in Princeton, N. J.

Larson has for some time been a member of the ATE Journal staff, covering the New York personals in the Field division.

## FINAL TENNIS TELECAST RADIO BEST MOBILE UNIT PICKUP

The highly successful completion of its four-day coverage of the Eastern Grass Courts Tennis Championships and the scheduling of its first professional baseball game—a double header between the Cincinnati Reds and Brooklyn Dodgers on August 26—were recent highlights of the National Broadcasting Company's television schedule.

The tennis finals on August 13 are considered to be the best mobile unit relay of an outdoor sports event accomplished to date, despite the 24 miles which separated the Westchester Country Club from the Empire State Building transmitter. The ball could be followed across the court on every play and the expert stroking of the contestants was clearly visible at all times.

Two cameras were used for the first time to provide flexible coverage of this event while telescopic lenses frequently were employed in following fine points of the play. Experience on this show will prove highly valuable in televising the forthcoming baseball game at Ebbetts Field.

In the studios, the outstanding event was the presentation of a film entitled "Leaders of World Peace and Democracy." This was shown in connection with the Columbia University Congress on Education for Democracy.

### ATE PUBLICATIONS, INC.

#### TRUSTEES

W. C. RESIDES	G. E. STEWART
R. D. COMPTON	H. E. MEYER
B. F. FREDENDALL	

#### ATE JOURNAL STAFF

H. E. MEYER	General Manager
G. E. STEWART	Treasurer
R. D. COMPTON	Editor
E. STOLZENBERGER	Assistant Editor
C. D. HAYS	Business Manager

#### ASSOCIATE EDITORS

Hollywood	R. O. BROOKE, J. KAY
Schenectady	H. C. MOSHER
Washington	A. R. MCGONEGAL
Cleveland	F. C. EVERETT
Chicago	F. C. SHIDEL
San Francisco	FRANK FULLAWAY
KFI-KECA	H. M. McDONALD
Denver	R. A. ISBERG
New York	J. LARSON, C. P. DICKSON, T. KRUSE
ATE Network	JOHN FRICKER
Mutual Broadcasting	R. A. SCHLEGEL
Columbia Broadcasting	M. ESCHER

The ATE Journal is a privately printed publication, issued by the Association of Technical Employees Publications, Incorporated, a corporation of the State of New Jersey with office located at 30 Rockefeller Plaza, New York City.

In the United States and Possessions: Fifteen Cents the Copy, \$1.00 the year (12 issues). In all other Countries, including Canada, Twenty Cents the Copy, \$1.50 the year (12 issues). Remittances from outside the United States by Postal or Express Money Order or by Bank Draft, payable in United States Funds. All prices subject to change without notice. All subscriptions must be paid for in advance.

Nothing appearing in the ATE Journal shall be construed to be an expression of the ATE Journal, or the Association of Technical Employees, but must be construed as an individual expression of the author or authors.

# RUMOR & GOSSIP

by ED STOLZENBERGER, NYV

This column is being written at Ticonderoga, N. Y., while vacationing; visited the Ticonderoga Pulp & Paper Co., and took a behind the scenes tour, from log splitting to shipping room; competitors are moving south to benefit from cheap, "docile" labor; this plant expects to be forced to move south in order to meet competition. The home-owning employee is the hardest hit as the result of the "Move South Movement."

It is healthy news that 15,000 General Motors Employees are back at work, with a promise of no illegal strikes during the 1940 Model production season.

There is a definite lull in the grapevine traffic lately—somewhat like the lull before the storm. A few months back, when all the visible signposts pointed to AF of L, and the NY Staff was forced to recognize the outside activity, President Ed Horstman came to NY, listened to the gossip and tales of woe, and then made the statement that we had at least 60 days to think out our course of action before the bubble burst. Well, he might just have well have said 60 years—it seemed too much to hope for. The 60 days have passed, a lot of smoke has cleared, and our ATE at this moment seems to have passed its crisis.

The AF of L's internal feud will probably add another 60 days to Horstman's estimate; it seems the 4A's revoked Tucker's AFA Charter, so Sophie ups and gets Charter from IATSE; in retaliation, the AEA, SAG, and AFRA have suspended her pending trial; this appears to be strictly a family fight, and there is some satisfaction in knowing that while they're pulling hair, they will be too busy to make a pass at us.

From an AP dispatch of July 25, "CIO leader John L. Lewis today invaded the building construction field, long dominated by the powerful and closely-knit building trades unions of the American Federation of Labor. In a formal statement, Lewis announced he would organize a new industrial union among the 3 million wage earners he estimated were in the industry."

UP dispatch of August 11, 1939: "The Building Trades Department of the AF of L and the Associated General Contractors of America announced today an agreement barring jurisdictional strikes on building projects. The agreement provides that henceforth, when such disputes arise on building jobs, there will be no cessation of work while the issue is being settled. The President of the AF of L Department will rule in the disputes . . ." It's about time! "John L" must have "Our Bill" really worried, to bring this about!

The anti-social faction of Big Business must certainly be enjoying a prolonged belly-laugh over the feudal wars of the CIO—AF of L; after the recent Sophie Tucker intra-AFL love-feast, it looks as though Union Strategists have called for a campaign to laugh Big Business into gentle submission. Watch your hat—you may have to run in a hurry.

August 4, from AP: ASCAP says, "We welcome the fight of the NAB, which announced it would attempt to break ASCAP's virtual monopoly in radio music. It is a sad state of affairs when these gentlemen, who sell commercial time to the amount of \$118,000,000. annually and will pay artists and performers and interpreters of music as much as \$15,000 for a single performance, cry and whimper because they have to pay the composers and authors of the nation about \$3,500,000. a year which makes their entire operation possible."

You have probably heard that Brown, NYSE, and Hiller,

NYSE, Technical Aides to ex-announcer John Young, In Charge of Radio at the NY Fair, have been released in the Fair's economy drive, and now are back at Radio City; G. Whalen is reported in the NY Daily News of August 5, to be seeking an RFC loan of one million; general contractors unpaid bills reported as high as twelve million. It seems to me there should be enough public spirited wealthy men in a city like New York willing to work without salary in return for the automatic publicity and advertising that would accrue to the job of managing the Fair. A lot of people object to supporting Mr. Whalen in the style in which he has become accustomed—in this case, \$90,000 a year. As an alternative, the Fair could be managed by a Committee of Exhibitors and Concessionaires, at no salary expense to the Fair.

From NY Daily News of August 11, Ex-employee sues Eastern Air Lines for \$200,000 for false arrest and malicious mischief; was charged with theft of \$591, and his life threatened; another employee, arrested on the same charge, was "caused to be strangled to death in a solitary cell on Jan. 8, 1939."

From the NY Daily News of August 5, Jack Haley, comedian, says, "A marriage in Hollywood or anywhere else, is a success if you don't have to phone friends every night to help you spend the evening pleasantly, if you can enjoy your wife's company quietly in your own home. It's the tipoff that marriage is not a success if you always have to go somewhere or fling a party every night."

We hear from the Dep't. of Agriculture that Yuma, Arizona is the sunniest place in this country, with 21 sunny days per month; 10 days per month: Los Angeles, and Springfield, Mo; 9 days: Dodge City, Topeka, Santa Fe, San Fran., Salt Lake City; 8 days: Freeport, La, Kansas City Mo, Oklahoma City, Boise, San Diego; 5½ days: Philadelphia, Washington, D. C., Boston, Chicago; 4½ days: New York. This is based on cloudless skies.

Christian Blot: Whenever the Spanish Inquisitions are mentioned, someone is sure to remind you that people were not civilized at that time, and that therefore the mass murders of healthy persons was excusable. When the recent Spanish Revolution between the Christian and Atheistic factions ended in a Christian victory, the news put a lot of people at ease who were worried about what punishment these awful atheists would inflict upon the defeated Christians. However, since the Christian victory, hardly a foreign news dispatch passes without news of mass executions of the defeated atheists; quoting from a UP dispatch of August 6, 1939, "Seven more were killed today, reportedly by garrote, ancient Spanish method of execution by choking and puncturing a victim's spine at the neck." It was shocking to hear Father Coughlin condone these mass executions in the name of Christianity, and in the same radio broadcast he said, ". . . and there arose a Franco . . ." to guarantee a Christian victory. In the year 1939, Christianity will be marked in history as a house divided; in Spain, the mass executions of healthy persons is applauded, while in the United States the legal elimination of pitiful cancer victims is opposed at every opportunity, and the hopelessly insane are permitted to maim themselves—at a staggering cost to the people; further evidence of Christianity dislocated, is the tooth and nail fight to defeat the Child Labor amendment; it is Christianity's duty to afford its young adherents every opportunity for education

and normal youth—instead, we find Christianity fighting to keep half a million children under 16 in sweatshops, mines, etc.—fighting, indirectly, to deprive half a million youths of their birthright to an American education, which can only be properly acquired during youth. The present administration of Christianity has diverged to the breaking point from the philosophy of Moses and Christ; our economic problems will not be solved until the Christian Pendulum swings back, reforms itself and cleans house, and demands and gets the social reforms necessary to reinstate the almost forgotten "American Standard of Living," and then makes this standard of living universal to Christian lands. From the NY Daily News Editorial of August 6, 1939, " . . . It appears that in the course of a Commons debate the other day Lady Astor squared away, looked some heckler in the eye, and remarked, 'My friend, if I had to go to work in a factory at the age of eleven, the red card of the Communist Party would not be half red enough for me.' In these few words, Lady Astor compressed a whole volume or more of profound philosophy. It is the Tories and diehards, hard-shelled employers . . . who make most of this world's radicals . . ."

UP dispatch of August 6 tells of terrorism by Japanese troops and Chinese mercenaries, aimed chiefly at British and American Missionaries. It seems to me the non-Christian peoples have been extremely patient with the white man's Christian Missionary activities. Charity begins at home; American missionary funds could be better used to provide the undernourished third of the country's children with adequate milk and hospitalize a great many tubercular children now running around our country-wide slums infecting other children. When our missionaries come home to service their own people, I shall be happy to subscribe to their support. How would you like to have a Shinto, Buddhist, or Mohammedan Mission in your community? How would you react if he tried to convert you to his religion? How would you react if he succeeded in converting some member of your family, thereby disrupting normal family harmony? On top of that, how would you like to see the mission buildings flying foreign flags, each its own native flag? You must have heard the bellyaching about the Russians' Red Star at the New York Fair, yet these same people are sending missions to foreign lands, to fly our flag on foreign soil, and demanding that the native respect the flag. To be neutral implies minding your own business; you can't be actually neutral toward a nation while your missionaries are disrupting the normal family life of that nation. When illiteracy has disappeared, when undernourishment of mother and child are unknown in the Christian countries, it will be unnecessary to send salesmen to foreign lands to sell Christianity to the Non-Christians; these peoples have heard the Christian philosophy preached, but they do not see the Christian philosophy practised by the white man's business organizations in their communities.

From the August 1939 RCA Family Circle, we quote in part, "General Harbord spoke at length on the question of submitting an incipient war to a referendum, affirming that such action was undesirable. 'The elected representatives of the American people,' he said, 'have never yet authorized a war which public opinion in our peace-loving nation did not support—and they never will.'"

The Hearst papers have inaugurated a swell series of articles exposing military propaganda activities in the United States. The material is based on a book by Sidney Rogerson, written and published in England, titled, "Propaganda in the Next War," and had a semi-secret status. The articles started in the Sunday August 6 Hearst papers, and are continuing in the morning Hearst papers; these articles should be read by every

potential front-line victim of the next war. You will learn how you are tricked into picking and "supporting" your "allies." Do you remember the mild rumpus raised during the last war, when the carefully aligned "public opinion" was aroused by a song writer who wrote the song, "I Didn't Raise My Boy to be a Soldier?"

Conn., NYV, replaced Thatcher as cameraman; Thatcher going to NY 9C Jeep.

Somers, NYV, flying to San Fran on vacation.

"Pinky" Clark, NYV, has been startling the Camden boys with his super-colossal cravats; Camden suspected death in family when Clark came in with average quiet necktie. After a few weeks of Clark's cravats, Beers, RCAM, got up sufficient courage to sport one of his "gift-ties."

Ray Monfort, NYV, authority on Sync Generators among other things, plans to drive wife and daughter Janette to Kansas, his tenth round trip in nine years. Any contenders for this record of consistent vacationing?

Television recently presented a Corset and Bra show; were cameramen Burrell, Stolzenberger, and Conn getting along swell?



You bet! Then Townsend and Protzman left the Control Booth to investigate—see adjacent photos; Townsend genially poses, while Protzman tries to get out of range of camera.

To the many in NBC who have worked with "Skipper" Schoenberger, but can't find time to visit the good ship "Lawrenceville," this will advise you that on a recent visit, the wife, Junior, and I found the Skipper smiling, happy, and in good health; his regards to all, and an invitation to "come down and see me" individually or in a party. Finished a perfect day canoeing on Princeton's famous Carnegie Lake.

From the August 1939 issue of QST, we learned of the passing of Dr. A. E. Kennelly, especially well known in connection with the how and why of high frequency skip effect.

Switch To Safety! Hardly an issue of QST goes by without the brutal announcement of another amateur's self-electrocution; this time it's W6NVE, who tangled with temporary connections to an emergency high voltage transformer. Let's get super-safety conscious, on the job and off; we know that the average ham has high regard for the advice of broadcast engineers, therefore, take advantage of the confidence placed in you and visit your local ham club at the first opportunity and preach the gospel of safety; arrange to bring along a prone-pressure resuscitation instructor from your local Red Cross unit to demonstrate and lecture on artificial respiration. Refer the hams to re-

continued on page 17



# SCHENECTADY

By H. C. Mosher

When a line amplifier fails, someone must "get the bugs out of it". That is the task which fell upon one of our gang last month. After spending some time on it, he suspended work until the next day. The next morning his efforts produced results. Fortunately the bug was found and placed on exhibit. None of the boys around here ever saw such a thing and until now had doubted its existence. Pete has steadfastly refused to reveal his hunting secrets, or admit what he used for bait!

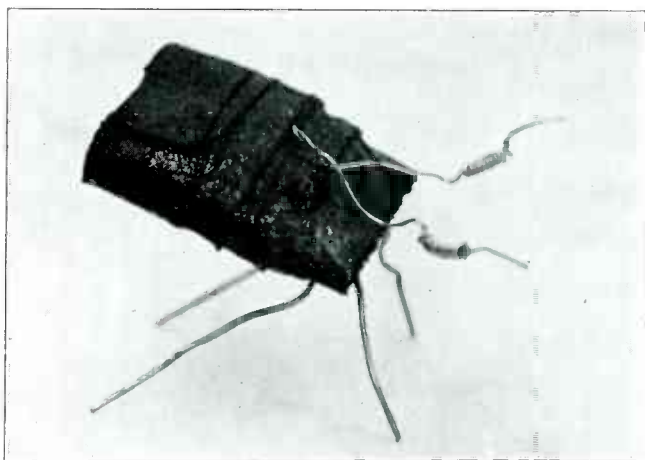

Nux Vomica

The origin of such a specimen is still a mystery,—though we suspect Al Knapp and Paul Adanti had something to do with this one. Ken Durkee finally gave it an appropriate name—"Nux Vomica". The picture will give some idea of its appearance. For further information we refer you to Peter F. Narkon, SE. He believes this to be the only specimen in captivity.

The Strongs had us all guessing for a while. They had planned to spend their vacation on Lake George. A day or two before Ray left he told us their plans had been changed and he didn't know where they were going. That was the last we heard from them. At this present writing we are still guessing.

The way things look now the Moshers will spend their vacation at home in Schenectady playing nursemaid to the new infant. One week before they were to leave, the trusted nursemaid they had was called home in an emergency.

We are very grateful to Miss Jessie Durkee, sister of Ken Durkee (SE), for arranging the material Ken collected into such an interesting story about MCC/MSW.

Mrs. Caranchini and Silvio observed their first wedding anniversary August 6. We all thought Sil was getting a good

wife a year ago. Now we are sure of it as Sil has put on twenty-four pounds in the last year. You better go a little easy on your wife's good cooking in the future, Sil.

By the way, Silvio's golf game is improving. He discovered the cause of his slice, went out for 18 holes, and broke a hundred. He came in with a birdie, two pars, and a score of 93. Sil, you better take Narkon and Adanti out and show them how to do it!

Bernard Curger took the second week in August for a short vacation, which was spent in Poughkeepsie and New York City. Crug had to get away from his Schenectady home as the alterations he is making there take too much of his spare time. We stopped in to see him the other evening and found him fitting the doors on the kitchen cabinets. We hardly knew the old place and must say he surely is doing a bang-up job.

The Schenectady bunch was pleasantly surprised to have Mr. Schuetz stop in for a visit last month. He was pleased with the good care Virgil Hasche, our office manager, was giving the new building. After a good old rag-chew, he jumped into the buggy and headed for New York.

## FROM SOUTH SCHENECTADY

We hear that H. F. (High Frequency) Vert is very proud these days. On June 17, Mrs. Vert presented him with a nine-pound boy. They have named their first son Richard Frederick. Congratulations!

We also wish to congratulate Mr. and Mrs. James Closson on the birth of their second girl, Judith Sylvia. Big Jim, as Closson is known at South, is now spending a few days installing a 250-Watt transmitter for police use at Plattsburg, N. Y.

Towlson and Schumacher took their vacations the first two weeks in August. When they return Yeandle and Lingle left for parts unknown. Mr. and Mrs. Vert expect to spend their vacation in early September, at Caroga Lake. During the same period Mr. and Mrs. Milham and "Butch" (a real boy) will be at Speculator for a rest in the Adirondacks.

The transmitting engineers were worried for a while after they learned that the shortwave call letters had been changed. Mr. Darlington, manager of shortwave broadcasting for GE, made it easier for them, however, by permitting them to say "WGEO, formerly W2XAF" and "WGEA, formerly W2X-AD". Habit is a hard thing to overcome, especially in a position like that.

# CLEVELAND

by F. C. EVERETT

SLIP AND SLATHERS. Everyone working plenty, enjoying slightly cooler weather of last few days . . . Recent rain much appreciated, came the last of July and was the only rain for the month . . . W. Pruitt and others with lawns appreciated it very much, as they all (the lawns, we mean) were looking pretty bad even with incessant sprinkling . . . McMahon and Whittam to Loudenville, O., for the railroading historical program pickup . . . Last few weekends keeping the boys on the go, local Soap Box Derby programs, Father Flanagan of Boys Town at the stadium, band pickups from Cedar Point four nights a week, hundred twenty miles round trip. National Poultry Congress, with pickups for the Farm and Home hour plus locals. National Soap Box Derby at Akron this coming week end for the net. Air races starting in about three weeks, which usually requires all hands and the cook. And a few golf games thrown in for good measure. Doesn't look like Disbrow will have trouble with anyone being undertime for the next few weeks . . . Cheeks joined those who are moving in closer to the folds of the transmitter by moving to Brecksville a short time ago. What with Stewart building a mile or so closer to Brecksville makes almost the whole gang in close proximity . . . Stewart is finding out more about housebuilding than he thought there was to it. Sezze, "If the contractor made money on the last job, it's OK, but if he didn't; you pay the difference." . . . Francis launched his boat a few days ago and she took to the water like a duck. We are still waiting that promised picture, and hope to have it by the time the ice boats are out . . . PX says it wasn't so bad buying the lumber, screws and whatnot, but the "hardware" has him broke and vacation is just starting . . . Makinson is busy trying to decide on an exposure meter to go with that complete movie outfit he purchased some time ago. We hear that he has an "art film" of some very nekked leddies, which we are anxious to see, but he has been keeping under wraps. The film, not the girls. . . . Caskey and Disbrow just back from northern trips into northern Michigan for Caskey and Canada for Disbrow. Diz claims they were biting and probably has a few tales and possibly an exaggeration or two to bear him out. Caskey reports they were not biting so good . . . One of those northern pike, from the bottom of a good cold lake wouldn't go bad at all, at all . . . One of Clark's girls was doing the Steve Brodie act out in the haymow and ultimately landed on a pitchfork—fanny first. Plenty of blood and plenty of fright, but the damage was comparatively superficial . . . B. Pruitt is the latest addition to the home owning fraternity. It's easy to see how his leisure hours will be spent. This ought to make the studio outfit almost 100% home owners, we'll have to check up on the situation and see just how it stands . . . Walker was looking for a pair of lost glasses out in the tall hay that is around the transmitter and while searching for them acquired one sweet case of poison ivy. It almost had him gaga. . . . Hay will be mowed shortly by the way, but Butler wishes it wouldn't be, since he figures that once hunting season starts all the pheasants will beat it for the transmitter grounds to hide and he can pick them off at his leisure and at will . . . Russell tried to furnish the whole neighborhood with hot water when his gas was left on all day, but the gaskets in the water meter finally let go and gave a nice fountain effect in the basement until he came home and took it apart . . . However, he's getting back the bread he cast upon the waters, for the illuminating company is furnishing free electricity since lightning cleaned

out the transformer and meter at his house. Bet that doesn't last long, though . . . Hackett isn't losing any weight while he is batching it with wife and child out east, so he is either a fine chef, or Berea has some excellent restaurants . . . Everett bought himself another miniature camera, so nothing is sacred now . . . Tops this month was McMahon's "Two transmitters! and I can't work them." It was a darned good pickup when they came in range, Mac, even if it did take a 30 mile antenna . . . Makinson delivered a radiogram to himself that Cheeks had left for him while making a prow through the NY Wurlz Fer . . . Ever hear of "eating tobacco"? Brandt ate his at one gulp when a firecracker was detonated underneath his chair shortly after the fourth of July. He must use it as a regular diet, though, for it didn't even phase him . . . Volume level differences between studio and transmitter have disappeared with installation of new VU meters, making those at both ends of the telephone line purr contentedly. Plenty of modulation and no complaints so the millenium must have arrived.

# WASHINGTON

by A. R. MCGONEGAL

During a recent visit to his summer home at Cobb Island, Md., Frank Fugazzi had an opportunity to demonstrate his knowledge of first aid. A neighbor called him to look after her injured son while she went to call medical aid. Frank found that the boy was bleeding badly from a cut artery in his foot, and applied a tourniquet. This undoubtedly saved the boy's life, as the nearest doctor was some twenty miles away, and the patient would have bled to death before he arrived. Incidentally, Frank recently bought a boat, complete with outboard motor. Trying it out, he started the motor, cast off the lines, moved some ten feet from the dock, and then the propeller fell off. Frank spent the rest of the day fishing for the prop with a pair of oyster-tongs. Locating it at last, he restored it to its place and started out. Five miles from home, the motor quit and no amount of coaxing or even strong language would start it again. He finally returned, late at night, by the old reliable paddle route.

Wally English's latest hobby is sound movies—he recently acquired a 16 mm. sound camera and projector—RCA of course. Wadsworth is another recent addition to the ranks of the 16mm emulsion scorchers, with a magazine-loading Cine-Kodak. There are five of the 16 mm boys now, and only two using 8 mm.

Scene—The huge relief map of Nova Scotia at the New Brunswick-Nova Scotia border. Wadsworth and McGonegal climb from car to photograph same, and run into Dr. Jolliffe, formerly of the FCC in Washington, and now with RCA, who was also photographing the map. A thousand miles from home and we run into a friend. It's a small world, etc.

And now for vacation news. Don Cooper is enjoying the fishing for a couple of weeks at Sunken Meadows, Va. Harold Yates is spending his three weeks at Ocean City, Md., where the marlin are reported to be pursuing the bait into the boat in their eagerness to strike. Simmons and English spent a weekend recently at Virginia Beach, Va. Williams is back from a vacation golfing in the Poconos, well browned by the sun. Bob Terrell is back after resting at Rehoboth Beach, Del., and then getting tired again at the Fair. Fisher has been to Wildwood, N. J., and the Fair. English spent four days recently at the Fair. Wadsworth and McGonegal went to Cape Breton Island, with a stop at the Fair. Fugazzi, Clark and Powley have also been looking it over. In fact, the Washington Engineering Dept. is practically supporting the Fair. Fair enough, Mr. Whalen.

# WOR

by R. A. SCHLAGEL

This must of necessity be a short column as I just came back from vacation and haven't been in touch with the goings on around here but I did hear that WOR recently made an application for a television license. This will give the fellows a chance to make use of their RCA television courses . . .

Jack Poppele, our chief engineer, off on a month's vacation tour of the west. I offered my services as guide and chauffeur but no go. How about looking into the possibilities of our opening a west coast branch of our recording department. I know just the man to send.

New Yorkers were treated to a great display of Aurora Borealis the other night, the show lasted about two hours. It's the first I've seen in the East and in the middle of the Summer. Kibling was out on a night fishing trip during the display and it being very quiet on the water, he could hear the sound effects of the display.

Pat Miller believes it pays to advertise in the "Journal." He's had several bids on his RME 69 and it looks very much like Pat will have that telephoto lens for his Contax. Just a reminder to you that "THE SHADOW" starts September 25th.

Jack Byrne spent his vacation near Riverhead, Long Island and had a swell time, spent most of the vacation fishing on Peconic bay and getting the big ones. (are you listening Reveal?)

Hadden spent most of his vacation on a golf course and is getting his score down to a respectable figure and adds that for a new angle to the game, try playing in a fog. Lots of fun watching the ball disappear in the fog. And he didn't lose a ball.

Eric Herud taking up golf now, plenty of practice will get you out of that 150 score class.

Jimmy O'Connor seems to be playing in the hard luck lately. Jim parked his car near the Essex House for a dance pickup, leaving his suitcase in the locked car. Came back to the car after the job and found the door lock broken and the suitcase stolen. Now, to add insult to injury, he tells me that his 6L6 crystal oscillator refuses to be crystal controlled, oscillating merrily on any frequency to which the tank circuit is tuned. You've got an ECO and don't know it! Tsk, tsk, and after all these years.

Charlie Kibling, W2EOA, is sporting a 10 meter mobile unit in his car. Kib can now work dx while he's on his way to a remote pickup. He's attempting to modify a nemo amplifier so that it will do a dual job of 10 meter transmitter and remote amplifier and he could continue the contact while he's on the air with a hot swing band. Kib is putting the finishing touches on a complete emergency transmitter and receiver just in case we have a re-occurrence of one of those heavy windstorms this fall.

Bill Ulrich getting his deepsea fishing tackle in order and will tempt the finny tribe with all sorts of lures, Bill will spend his vacation at Montauk Point where they really catch the big ones. (Reveal please note).

Ed Scatterday, Paul Reveal and Shirley Davis on a fishing trip recently, about the only things caught were a few small sand sharks. Ask Reveal to tell about the one that always gets away.

I wonder who was responsible for the choice of ET that was used the other day to fill in during a network line failure. Selection used was, "Nobody Knows the Trouble I've Seen" . . . How true!

I've never had a vacation that was over so quickly, spent a few days seeing the World's Fair and the rest of the time spent resting at home, you all know the kind of rest; mowing the lawn, pulling crab grass, repainting furniture and building a pine panelled room in the basement and then when time was hanging heavily on my hands, attempted several pictures for the "Journal" contest. Be glad when this hot weather is over. Suppose then we'll be complaining of the cold and how much oil it takes to heat the house. Still a few days left to get in your photo entry.

---

## LAST CHANCE TO

Send in your entries NOW  
for the

**Annual PHOTOGRAPHIC CONTEST**  
The deadline for entries is September 15  
Three valuable merchandise prizes will  
be given away!

### CONTEST RULES

1. Any reader of the ATE Journal may enter the contest.
2. Contest will end September 15, 1939. All entries received postmarked later than midnight September 15 will be disqualified.
3. All entries must be between 4" x 7" and 11" x 14" in size.
4. Entries must not be mounted or framed.
5. No entries will be returned unless accompanied by self addressed and stamped mailing carton or envelope. No entries so sent will be returned before October 15.
6. Entries depicting some phase of radio in either still life or action pictures are preferred, but not required.
7. All entries must be accompanied by a statement as to: type and size of lens; make of camera; exposure time; aperture of lens. Other data pertinent to the taking of the photograph.
8. All prizes will be awarded on the date of publication of the October issue.
9. The decision of the judges will be final.

Send entries to ATE Journal, 30 Rockefeller Center, New York City.

---

# CHICAGO

F. C. Shidel

M. W. (See Me R. E.) Rife spent his vacation painting and decorating his home. sea lion that had routed him.



NBC Picnic—9th hole Beer Station—location Bon Air Country Club. Left to Right—Curt Pierce, F. E., Harold Royston, F. E., Lloyd Hackin, S. E. and Ed. Bernheim, S. E.

Bill Cummings had a good day at a local track recently—two got him fifty while he was riding gain on Clem McCarthy.

Charlie Townsend, N. Y. television, and wife visited the Chicago studios during vacation.

Connie Conrad will be driving a 1940 Pontiac in a few weeks.

Bob Whitnah is moving to Villa Park.

J. F. Mehren is working vacation relief at the WENR-WLS transmitter.

Frank Fullaway's idea of each chapter making a movie short of local activities, equipment, personnel, etc. for circulation to other chapters has met with approval in Chicago by a large group of camera men—all that remains now is to decide on either 8 or 16mm. straight or color.

Bob Whitnah came to work rather wacky one day last week—he had been helping Horstman and Maker assemble and staple the 29 page "New Constitution" which is now ready for release. The many trips around the composition table sort of got them down.

Curt Pierce, F. E., not being a naturalist, was severely shaken up mentally when a sea lion objected to Curts' prowling around in the dark back stage at the Chicago Theater, while preparing for the Mars Candy Show. Pierce lost no time in getting out of the place and didn't find out until later that it was a trained

Lenore Kingston, NBC actress, has completed the "RCA Ham Course" and now is operating W9CHD on 40 CW—20 Watts. She was coached by some of the Hams in the engineering department. Jules Herbuneau, Program manager and Rex Maupin, orchestra leader, got together and built a transmitter for her.

Guess Joe Kay doesn't bother with the output to line connection when he puts Mr. Hays on the Wireless—"RCA Family Circle"—August.

Bill Knight back from vacation spent in Iowa and Pennsylvania looking about five heavier.



Here's one that didn't get away—Dave Kempkes spent his vacation in Canada and claims he caught more this size.

## CHICAGO ATE AMATEUR ACTIVITY

During the past several months there has been a decided slump in amateur radio here in Chicago. The talk in the control room seems to run more to fishing, golf and vacations rather than rotary beams and elements. There have been several old timers who have kept the colors flying for amateur radio through the Summer and we propose to tell you something of them. These men are "Jim" Platz (W9GY), J. R. Miller (W9CP), and Glenn Webster (W9JIR). Several other men have been on the air during the Summer but they have not participated in the "network" operations. Eichorst (W9RUK) has been on the twenty meter phone band and has made some contacts with NBC men in other offices. We are glad to see this 20 meter phone gang get started and hope that it will soon rival the CW network.

Here is a little more information about these fellows who have been on during the Summer. Platz is the first man listed

continued on page 16

# HOLLYWOOD

by BOB BROOKE

FLASH . . . SF Andresen dates LaMour . . . Brooke dives for anchor rope wound in prop . . . Andy swims for dingy adrift . . . 317 lb. Marlin lost . . . Mutiny on the Bounty . . .

By wireless from MS "PUP" . . . ISTHMUS, CATALINA ISLAND—Always wanted to sail around the world in a small boat, so while vacationing, Andy Andresen of SF studios and I are circumnavigating Catalina for practice. We're anchored in the Isthmus cove far from the hubbub of Avalon's Coney Island. Here the water is clear and deep blue. The natives are visiting yachtsmen and beachcombers. The village is more south sea than the south seas as it was once the motion picture set for Mutiny on the Bounty. The bar is Christian's house . . . The general store was the picture's general store . . . The wharf, small boats, real palms, big moon, many thatched huts complete the effect. Pictures have again taken the place over, however, and not a cottage is available because Paramount are here with a company shooting outdoor scenes for a new LaMour picture to be titled Typhoon. So Andy and I discovered that if we wanted to visit the Isthmus we would have to bring our own accommodations . . . Hence our charter of the 28 foot PUP. And are we having fun . . .

There are few satisfactions as great as rounding the last of Uncle Sam's regulated breakwaters and heading your own boat out into the open sea. Hoping that if the compass is right and you have read the chart correctly, you'll eventually arrive where you're going. Then it's fun to watch the orange peels and murky harbor water disappear with the sight of land and the clean navy blue sea with flying fish and porpoises take over the scene. And it's fun to be able to turn your boat in toward a cove when you see one and explore islands and places to which only boats can go.

Enough of that, this is copy for a bunch of sea going brass pounders. Eleven years ago I was too. And even sailed to Honolulu in a Lipton race. But, that many years twiddling knobs and watching dials returned me to the ranks of the landlubbers. Avalon was the cause of it all. Avalon and Andy's jitterbug instinct . . . We anchored where heavy sea swells required our moving after nightfall. We broke our tender control booth backs trying to hoist anchor before we discovered it was a simple matter to break the anchor free of the bottom with the engine . . . And in re-anchoring amongst a group of yachts we neglected to figure drift . . . And in pulling up those anchors we backed into a slack aft anchor cable and dingy painter, winding the cable up a dozen times on the prop and cutting the dingy free to be discovered almost a quarter of a mile ashore. Andy swam for the dingy. Brooke started a dead engine and shoved off the nearest yachts. Upon Andy's return Brooke tackled a sad mess of one inch rope tangled in prop and rudder. Luckily we finally drifted into a neighboring fixed mooring. With prop cleared and anchors back on deck a shot of grog reminded the nearly exhausted crew that we had come to Avalon to dance. So with firm determination we donned starched collars and rowed ashore at midnight to finish the evening dancing to Ted Weems and his Orchestra.

Next day we left Avalon without even saying goodbye and headed back for the Isthmus, fishing as we went . . . Apparently our fishing gear or technique wasn't right because we lost some of the biggest and prettiest hooks you ever saw and with the hooks some big fish . . . (Largest 317 lbs.) . . . Andy sez I

shouldn't have advised, "Don't give him any slack" . . . "Haul him in" . . . Thinks our methods were too rough and the fish too big . . . Raw hands and sore arms still remind us of those fish . . . and anchors . . .

Anyway, now safely anchored at the Isthmus cove we have little to do but lie in the sun on deck, sail our slick little sailing dingy, paddle paddleboards, catch smelt and perch, have dinner on the veranda of the Island Hotel, drink long cool drinks afterward, and think about dancing with friend Dorothy . . . What nights . . . what moons . . . what a place . . .

BACK AT STUDIO . . . Latest startling stunt has been re-broadcasting of Eastern shows via our reference recording equipment . . . New situation has already added grey hairs to Mort Smith's head . . . Middle switches in half hour shows are extremely difficult to cue accurately and Mort is already laying out an improved mixing system for network playbacks . . . Ken Carpenter sez new quotation for announcers will be, "One moment please while we replace the needle" . . . and what happens if technical difficulties or groove jumping or cueing should delay a commercial recording fifteen or thirty seconds and cause a network runover . . . Oh me, we'll find out in due time . . . Mort and Bob advise that new amplifiers and equalizers are in service in reference recording for a new recording system of NBC development called "Pre-Emphasis Recording" . . . Understand the new system is a modification of the old pre and post equalization methods used in pictures and vertical recording to effectively reduce surface and noise from six to twelve db . . . Hope for a story on it in the near future . . . Hollywood playbacks with the new system are almost impossible to distinguish from the original pickup and are far ahead of the commercial local output . . .

JOURNAL . . . Journal chief Henry Meyer and wife spent a week with the O'Kellys at their San Fernando Ranch . . . While here they were partied and feted and tripped thruout the southland . . . Meyer and Brooke played off the long discussed golf game and I am happy to announce that Hollywood came out victorious by a decisive margin . . . Jake and Gert drove the Meyers down thru San Diego and Tiajauna and back thru the desert and high mountains on a nice two-day trip . . . Henry conferred with ATE officers in Hollywood on matters pertaining to the Journal and regarding his recent visit with President Horstman in Chicago . . . They were shown such a good time that both Henry and Mrs. Meyer agreed that California was really all right . . . Glad to see you Henry and come again . . . My humble apologies to SF on spelling Nob Hill, Knob . . . Guess I was thinking of mixer knobs or door knobs . . . Noted error before Journal came out but was too late to correct . . . Boys advise Nob was derived from words Nabob and Snob, as hill was called when ruled by early California tycoons . . . Oh yes, before we leave Journal subjects . . . Henry Meyer got quite a ribbing from the old NY hams who report he had to come out here to work his first W6 . . .

VACATIONS . . . The Joe Kays to Banff and the Canadian Rockies via all the Western National Parks . . . Joe and Marion are driving their '35 Ford . . . Don DeWolf back from two weeks camping at Yosemite . . . De deserted his favorite Lake Tahoe this year . . . Ken Hicks showing his family from Chicago thru the West while on vacation . . . Likes Yosemite

continued on page 16

W6 137 - W97N - W60A  
Evansville Ind  
MPS  
Joy Scher

# FREQ CHECKER FOR HAMS



Frequency standards heretofore utilized by hams for the most part been of the tuned oscillator variety which provide continuous frequency coverage but limited accuracy, or crystal oscillators which are accurate but provide only a limited number of check points. What the ham now needs more than ever is some form of frequency standard which combines the accuracy of the crystal with the flexibility of the tuned oscillator.

A very close approach to this seemingly impossible combination has been introduced to the amateur field in the Hallicrafters Model HT-7 Crystal Frequency Standard. While it is not tunable and therefore does not offer quite the flexibility of a tuned oscillator, it does provide output signals only 10 kc. apart up to about 15.0 megacycles. These are close enough together to permit accurate interpolation of in-between frequencies right down to fractional kilocycles. In addition, this output is not only crystal controlled but is controlled by a crystal which is adjustable and with which an accuracy of better than ten parts in a million can be obtained and held for hours at a time.

As a basis, the HT-7 employs a dual-frequency, 1000-100 kc. crystal. To this is added a multivibrator locked in with a sub-harmonic of the 100-kc. crystal position to provide the 10-kc. fundamental output. Both the crystal oscillator and the multivibrator feed into a 6L7 which serves as a mixer, buffer and TUNABLE harmonic amplifier. As a result of this latter feature, harmonics of the 10-kc. output are usable to 15 mc. or higher, and harmonics of the 100 and 1000 kc. outputs are available to above 60 megacycles. The mixer application of the 6L7 is utilized to combine the 100 and 10 kc. outputs to allow the stronger 100-kc. harmonics to serve as "markers" as an aid in identifying the 10 kc. harmonics. Thus in tuning a receiver through the 10-kc. harmonics every tenth one will be strongly emphasized.

The complete schematic circuit is shown herewith for readers who are interested in the details.

When the frequency selector switch is thrown into either the 100-kc. or the 10-kc. positions it inserts the 100 kc. tuned circuit in the oscillator plate and shunts a small variable condenser across the crystal itself. It is by means of this condenser that the crystal is adjustable over a narrow frequency range. With the output fed into the receiver and the receiver tuned to WWV's standard-frequency transmissions on 5.0 mc. the 50th harmonic of the crystal is adjusted to zero-beat with WWV to obtain precisely 100 kc. fundamental output. If the receiver boasts an "S" meter or other resonance indicating device, it will show the beat as zero is approached and will permit adjustment

to within a very few cycles which, at the crystal fundamental, will represent a small fraction of one cycle. If the unit has been allowed to reach stable operating temperature before this adjustment is made, the accuracy will be maintained indefinitely so long as the room temperature does not vary materially.

In addition to its use by hams in checking frequencies and adjusting ECO controlled rigs, it is obvious that such a frequency standard will find many other applications including receiver calibration and alignment, calibrating and checking all sorts of test oscillators and frequency meters, checking-circuits for drift, etc. All of which make the HT-7 a general utility device which should find wide use among not only hams but technicians and experimenters as well.

MODEL HT7 FREQUENCY STANDARD

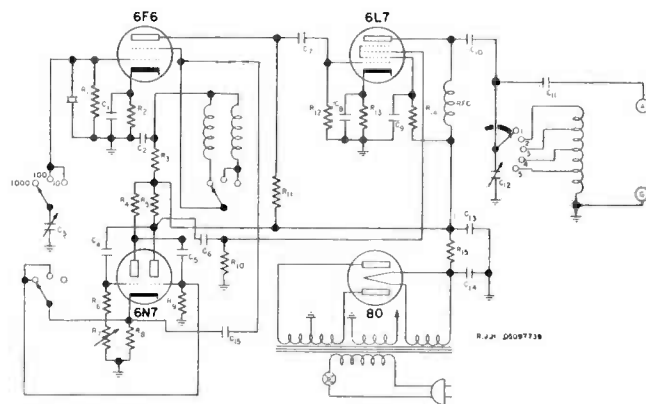

RESISTOR		CONDENSERS	
R	Ohms	C	Capacity
1	5000000	1	.1 mfd.
2	500	2	.1 mfd.
3	25000	3	25. mmfd.
4	2500	4	.002 mfd.
5	2500	5	.002 mfd.
6	20000	6	.002 mfd.
7	15000	7	.001 mfd.
8	300	8	.01 mfd.
9	30000	9	.01 mfd.
10	50000	10	.002 mfd.
11	85000	11	10. mmfd.
12	100000	12	
13	500	13	8. mfd.
14	15000	14	8. mfd.
15	7000	15	35. mmfd.

*New Jersey's Leading Ham Parts  
Distributor*

**ARRON LIPPMAN & CO.**

246 CENTRAL AVE.  
NEWARK, N. J.

PATERSON:  
79 Bridge St.

NEW BRUNSWICK:  
54 Albany St.

# NEW YORK

by TED KRUSE

Things that make you feel as if you had never been away on vacation: John Kulick talking ham radio and smoking a pipe . . . Doc Dickson rubbing backs . . . A. T. Williams and Montilla arguing and using such endearing terms . . . Christopher complaining about Aunt Clara . . . Bill Glasscock looking pale and rushing to or from a Fred Waring rehearsal . . . L. L. Lane knocking his fist through a door . . . C. W. Phelan checking up and looking for Prof. Stewart . . . Prof. Stewart looking for Phelan . . . Paul Herrold smoking his third pack of cigarettes tax and all . . . Saunders chewing gum and burping . . . Charlie Bennis laughing at the latest joke . . . Ted Hahn carrying movie equipment and magazines . . . Buddha Whittaker hurrying to a rehearsal at one mile per day . . . Andy Waddell with a batch of blue prints . . . Carl (I can get it for you wholesale) Clark ordering something . . . Ed Costello performing a major operation on a mike . . . Kitchen yelling at some Field Engineer on a Nemo job . . . Ed Gundrum heckling somebody . . . Mel Lewis relaxing . . . Curly Jordan praising Denver . . . G. Sellar looking cool and collected during an emergency . . . Hank Geist and his collegiate hat (at his age too) . . . Staff cars not running till six P. M. . . . The midnight trick.



At the O'Kelly Ranch, San Fernando Valley. Left to right—Bob Brooke, Hollywood Rep., Gertrude O'Kelly, Henry Meyer, General Manager and Mrs. Meyer.

The Meyers spent a most enjoyable week at the O'Kelly Ranch located in the San Fernando Valley, California. Lorenze, Norman, Miller, Capstaff, and Moss wished to be remembered to the boys back east and Kay was on vacation up in Canada. The west is all that the boys have claimed for it according to Meyer. If convincing was necessary, a trip to Mt. Wilson, Mexico, Big Bear, and the Mojavi Desert where seashore, the mountains and the desert are one hour apart soon dispelled all doubt and although Brooke took Meyer at a game of golf, Meyer is still "happy about the whole thing." Jake O'Kelly, by the way, spends most of his time sleeping out in the sunshine on the front porch of his ranch. "Someday," Jake says, "I'll come back to New York and visit the boys"—Andy Waddell and wife arrived just as the Meyers were leaving. It's a small world after all.

## CLINTON F. GLUCK

It is with a deep sense of regret that we mention the passing of Clinton F. Gluck, a member of the Engineering Department stationed at the WJZ transmitter at Bound Brook, New Jersey.

Mr. Gluck died in May, at the U. S. Naval Hospital in Brooklyn, New York, after a prolonged illness of seven months. His death is deeply felt by all those who worked with him.

Mr. Gluck joined the staff at Bound Brook in October 1929. Previously he had served in the U. S. Navy for twenty-two years and at the time of his death had completed eight years in the U. S. Fleet Reserve and was on the retired list. During the World War he served as a Warrant Officer. While a resident in Bound Brook, he was active in civic affairs and a Commander of the local post of the American Legion. He was a member of the U. S. Fleet Reserve Association and of the Veteran Wireless Operators Association.

He is survived by his widow and a son, Fred, who is now serving in the Navy. To them we extend our deepest sympathies.

## WHOLESALE RADIO SERVICE CO., Inc.

Changes Name to RADIO WIRE

TELEVISION, Inc.

Wholesale Radio Service Co., Inc. prominent for 20 years in the radio industry, announces a change in the company name and its operating policies.

Mr. A. W. Pletman, president of Radio Wire Television, Inc. states, "Our company is on the threshold of a new era in the development of communication services, which necessitates a change in our name and operating policies. The new name, Radio Wire Television, Inc. embodies, we believe, those features which from now on will comprise the most important part of our business. The company plans to expand its activities into every phase of the electronic art. We have recently become affiliated with several new associate enterprises which will control important patents relating to the entire communications field. With these patents we hope to open up a vast number of new services to the general public. Of special interest are our plans to expand the number of retail outlets of Radio Wire Television, Inc. so as to place local branches at the convenience of everyone interested in finer entertainment services, better products, and lower prices."

Radio Wire Television, Inc. is licensed through arrangement with Electric Research Products, Inc., under the patents of Western Electric Company, Bell Telephone Laboratories, Inc., and American Telephone and Telegraph Co.

## AS A MEMBER OF A T E

You are privileged to enjoy our volume discounts  
on all your needs.

Check with us on any of the items listed below:

RADIOS	RADIO TUBES	REFRIGERATORS
SILVERWARE	WASHERS	VACUUM CLEANERS
SEWING MACHINES	TOASTERS	BRIDGE SETS
TYPEWRITERS	IRONS	HEATING PADS
WAFFLE IRONS	VIBRATORS	SUN LAMPS
JEWELRY	MIXERS	IRONERS
PENS	CAMERAS	FURNITURE
PENCILS	FURS	CLOCKS
FANS	RUGS	PROJECTORS
HAIR DRYER	STOVES	WATCHES
MATTRESSES	LEATHER GOODS	BABY COACHES
SPRINGS	AUTOMOBILES	ELECTRICAL
AIR CONDITIONING	TIRES	APPLIANCES
ELECTRIC RAZORS	AUTO RADIOS	HOUSE FURNISHINGS
CARPET SWEEPERS	AUTO HEATERS	LADIES' HOSIERY
KITCHEN RANGES	MEN'S NECKWEAR	PHONOGRAPHS
ROASTERS	LAMPS	RECORDS
OUTBOARD MOTORS	ELECTRICAL	SPORTING GOODS
PING PONG TABLES	FIXTURES	SODA SIPHONS
CHINAWARE	COFFEE MAKERS	BLANKETS
	LUGGAGE	

### Wholesale Masters, Inc.

COOPERATIVE BUYERS OF STANDARD MERCHANDISE

Write in for Our New 1939 Catalogue

48 WEST 48th STREET NEW YORK CITY

Eighth Floor  
Phone BRyant 9-7727

The place to buy anything in radio is at

"SUN". - WHY!

Because "Sun" carries a tremendous stock of radio parts, receivers, tubes home radios and records.

Fast, efficient service and at low wholesale prices.

Seventeen years in the business of selling radio only.

Ask for our brand new catalog.



## DENVER

by AL ISBERG

As the end of the vacation season approaches, we regretfully acknowledge that two men with whom we have been privileged to work during the summer months will have to place themselves in some other positions.

In order that the industry served by the Journal might be in a better position to know these men, I have gathered a few facts about each, hoping that they may be speedily placed.

The relief man at the 50B transmitter is George H. Anderson, W9IPH, George graduated from Colorado University this spring with an E.E. degree. In spite of the fact that he worked his way through the University with a handicap of supporting a wife and baby son, he graduated with honors and belonged to several honorary societies. Another son was born several weeks ago adding to his responsibilities.

While in school, he serviced radios, ground crystals, custom built high frequency ham equipment for those who didn't want to or could afford to buy it built to order.

He came to us highly recommended by the E.E. department of Colo. University and his work has been very satisfactory. About half of his time has been on routine operating and the other half on maintenance finding out what makes a 50B tick. This experience should make him a good choice for any 50KW station, although George is not choosy about the size of the station. He will be available about October 15.

Our studio relief has been Vern Andrews, W9BEA (the mile high zoo, zebras, elephants, apes) who transferred from guide and elevator service. He will complete five years with NBC this fall when we celebrate the opening of the present studios.

Vern received his B.S. in E.E. from Denver University in June. He was second in scholastic standing in his class and made Math., physics and E.E. National honorary Frats.

Evidently the four and half years of being around the place was a great benefit because a check of operating errors revealed that he had fewer operating errors than some of us who have been in the department a number of years.

Vern is a very likeable fellow and his personality makes him an ideal chap to work with. All of us wish our program load would increase enough so that he could remain with us.

Both men have Radio Telephone First Class licenses.

Latest reports of the relief men of last year are that Ed Smith is on the faculty of the State College at Bellingham, Washington, and also serving some time at KVOS. Jim Moran, the transmitter relief was last reported at KMOX, St. Louis.

Rohrer objects to Hathaway of N.Y. claiming the Indian wrestling championship. He says, quote "First he wore me down teaching me to play the harmonica. Then he gave me firewater. Then I threw him left handed and everyone knows Lew is a champ left handed tennis player. But I still don't know how he threw me right handed—at least I was champ of everyone I'd tackled before but I'm looking forward to taking him on again next year—and I'll know better than to get a glass arm playing a harmonica first"—

The Rocky Mtn. A.R.R.L. convention is absorbing all of the spare time of Stan Neal, Al McClellan and Glen Glasscock. It looks like a bang up affair this year with a lot of fun and prizes for all.

Neal reports excellent fishing in the Tetons of Wyoming and brought back color movies to prove his stories.

Suggestion of Fullaway regarding circulating chapter movie is excellent idea. I believe we will come through on it with a nice reel about KOA activities.



# Long Distance Television Reception

DEAN R. BARKER

Since the distance over which presentable television signals may be received does not usually exceed fifty or sixty miles, it was with no little surprise that I learned, from recent tests, that very passable images could be obtained from W2XBS, in New York City, at my portable receiving station near Falmouth, Massachusetts, an airline distance of approximately one hundred eighty-five miles.

Having worked amateurs in the 56 mc band over greater distances than this, it occurred to me that television reception from the New York station might be feasible. With this idea in mind, a spot was chosen which would utilize a "line of sight" transmission as nearly as possible. The location near Falmouth seemed to be ideal in this respect. Unfortunately, there was no electricity available, so a well shielded and filtered generator was brought into service. A voltage regulation system was found to be necessary as the output of the generator was not stable enough for proper operation of the receiver.

The receiver itself was a home made superhet using 1851 type tubes for r. f., i. f., and video amplifiers. The kinescope

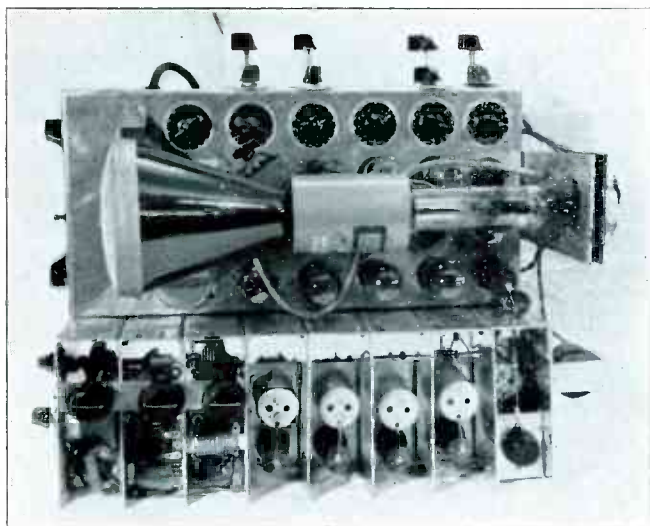

used was an RCA 1801 five inch type. This tube gave a resulting picture of about  $3\frac{1}{4}$  inches by 4 inches, large enough for general observation. No sound channel was built into the receiver; the audio, when it was received, was picked up by means of a separate set. Multi-vibrator circuits were employed in the horizontal and vertical sweep generators.

Now a word about the quality of the pictures received. To date, six separate tests have been run, all of which took place during June and July. Of these, two were comparatively perfect in regard to picture quality and consistency of reception. From the clarity with which these broadcasts, apparently spot pickups and World's Fair events, were observed, it seems evident that further experimenting may prove fruitful. The chief difficulty appeared when automobiles passed on the road, some three hundred yards away, creating a "snowy" effect in the kinescope, and usually necessitating an adjustment in the synchronization controls. At other times complete or partial fading of the picture, accompanied by distortion, took place. Many of the "bugs" encountered were traced to the source of power, antenna

coupling, and in one case, to a shorted tube in the vertical sweep.

It was interesting, though aggravating, to note that in general, while the video signal was good, the audio was barely perceptible, and vice versa. This was accounted for by the fact that separate receivers were used, and also that the higher frequency audio carrier was affected in a slightly different phase relationship from that of the video signal.

Several types of antenna were tried, but the one that gave the best results was a horizontal half wave doublet, used in conjunction with a reflector. The effective height of this assembly above sea level was approximately one hundred and twenty feet. Both open wire and coaxial lines were tried, the coaxial cable being the easiest to use but the best results were obtained with the open wire line.

At the present time a new antenna is in the process of construction and a new location has been decided upon, two factors which may increase the possibilities of more consistent reception. The receiver is also undergoing several changes, including the addition of an integral audio section, in the hope that much more faithful reception may be expected.

The recent tests thus stated, have been more or less general and somewhat haphazard but the results have been so gratifying that plans for employing a commercial receiver are under way. Future testing will be made at regular intervals and with more complete equipment so that a definite knowledge may be had of the vagaries of television reception at this comparatively long distance.

## ON THE STUDIO BEAT

broadcast over NBC was another example of the ingenuity of Ray Kelly's SOUND EFFECTS development crew. On a previous occasion a regulation table was assembled in the studio but the sound produced wasn't satisfactory to the experts. So, they constructed a special frame, equipped with a special pocket, which is attached to any ordinary work table. It not only works perfectly but gives the boys a chance to brush up on their game in spare moments.

In recognition of five years of broadcasting Hymns of All Churches, JOE EMERSON and associates will be awarded the Radio Varieties gold cup on July 31. The honor has been accorded the program "because it brings to the radio audience the most beloved hymns of all the major creeds and fosters a feeling of tolerance and good will." The presentation will be made on the start of Emerson's sixth anniversary week.

Out in Hollywood, where the NBC GROUCH CLUB meets, Grouchmaster Jack Lescoulie refused to permit Ned Sparks' Nomination for the grouchiest man in America on the grounds that he had gone "professional," but his professional services to the cause of gloom-casting were recognized in his appointment as a judge.

Few heroes live to see statues erected in their honor. CHARLIE McCARTHY is one of them. During his recent visit to the New York World's Fair his splinters trembled with delight when he saw that greater-than-life effigy of him in the Chase and Sanborn exhibit. Rapidly gaining his hard-wood expression, he modestly muttered: "Just another chip off the same block."

## HOLLYWOOD

continued from page 11

much . . . He should see it in the spring . . . or even in the winter for winter sports . . . Miv Adams and wife drove 5500 miles thru eight National Parks including Glacier and Yellowstone by way of Seattle and Victoria BC . . . Certainly lots of people visiting Canada this year . . . Hear the flower gardens in Victoria are magnificent as they were added to for King and Queen . . . Miv shot 200 Contax pictures and exposed six 9 x 12 cm. Kodachrome negatives in his Voightlander . . . Hope some are Journal material . . . Al Korb staying home to work on the new house but will probably spend a few days at Catalina . . . Everybody goes to Catalina who don't visit their home towns, pickup new cars in Detroit, stay home to work on lawns, or visit the World's Fairs . . . understand the New Yorkers here who get their vacations late are planning some deer hunting . . .

MISC . . . Carl Lorenz held a house warming at his beautiful new place . . . or should I say a few of the boys held one for him . . . anyway a great time was had and a really grand new home was dedicated . . . Carl has his radio shack acoustically treated and separated from the sleeping rooms . . . The famous moose head occupies one wall of the shack along with other mounted heads and trophies . . . A built-in gun cabinet holds Carl's target and hunting rifles . . . Glass tubes thru the walls will carry antenna feeders . . . The shack is a "he-man's" room . . . Carl is rebuilding the 1kw rig, however, before returning to the air . . . Charley Russhon was there with his wife and report Dutch well on the way to recovery . . . Mort Smith's new home coming right along and will be a honey . . . MO has light and telephone run in in conduit underground to eliminate antenna complications . . . Mrs. Smith east with her mother to pick up a new car . . . Whole NBC AA gang riding Monday evenings and then adjourning to a member's home for cocktails and fun . . . Understand a couple of our funnier actors are going along and turning in some fine acts afterward . . . Frank Figgins is building a darkroom as an addition to his house . . . Has bought Bob Schuetz enlarger . . . Eddy Miller never drinks but reports his hands felt funny after several smooth cocktails at the Lorenz party . . . Earl Sorenson still catching up on his wardrobe and planning a move to NBC Village in San Fernando Valley . . . Ken Carpenter had his appendix out and spent a week in the next room to Denny at the Hospital . . . Jake back at work and feeling fit . . . Denny due back next week after six weeks in the hospital and at home . . . Buddy Twiss very busy with a big rush of special events . . . Eddy Miller getting a lot of use out of his sleeper coupe . . . Al Korb digging a swimming pool at his new place . . . Expect OB out in September for his first look at new Radio City since its completion . . . Kay Phelan entertaining several friends from her home town . . . Kay and Alice Tyler still collecting candy . . . Our budding lawyer Brown brought a pair of white coveralls to the studio and has been noted pulling new cable with sleeves carefully rolled up . . . Publicity sez, "Anything for a laugh" or a picture . . . They brought a sadly dismantled 44BX in to maintenance the other day and gave the boys a scare . . . Told 'em some pictures of Baby Snooks required showing her wrecking a microphone and here it was for them to put together . . . Upon investigation the mike housing was found to have been carefully unscrewed by another engineer for the picture and 'twas just a gag . . .

PS . . . Being on vacation I'm kinda stuck for studio material so will try and make up for it next issue . . . But would like to mention few days spent in San Francisco last week . . . New NBC AA up there threw one of the best picnics and all day

parties I've ever seen . . . Office force were given a holiday . . . Swank country club was taken over and all hands turned to their favorite sport and all were represented except skiing . . . Fine dinner followed and then dancing to a swell band until three AM . . . It was a party that will be hard to beat in Hollywood . . . But we will . . . Fine bunch the San Franciscans and fun . . . Stayed at Tad Fullaway's . . . Has a fine apartment and you should see the wedding presents . . . Went up to finish seeing the Fair . . . Spent two days hiking thru it and still say it's stupendous and colossal . . .

Hope you all had fine vacations . . . From the Hollywood gang to you 73.

## CHICAGO

continued from page 10

so we will talk of him first. He is well known around Chicago having been an officer in the York Radio Club, has long been an active member of ARRL and is connected with most everything "radio" around Chicago. Platz is the present Secretary-Treasurer of our ATE chapter and is a Junior Supervisor in the Chicago office. He is a swell operator and is always experimenting with his rig. For this reason his power and transmitter line up is never fixed. Next to radio his second hobby seems to be photography. He says he is looking forward to the regular schedules in the Fall when the entire gang can be on from coast to coast.

Miller is another old timer in the ranks of radio and tells of block long antennae and rotary gaps in the early twenties. He is another experimenter and frequently comes to work with a perplexed look telling of a huge flash in his transmitter when a bunch of condensers blew. He uses great quantities of "Juice" and the power transformer on the alley pole is said to glow a cherry red when he fires up with W9CP. At present Miller is building a super de-luxe three element rotary beam in an effort to concentrate some of his power in a given direction. He is one of the best operators in the middle-west and enters all the speed contests as they come along. We expect to hear more from Miller this next Winter.

Webster is another amateur whose first transmitter started up back in the dark ages. He has been operating on phone and CW intermittently for the past eight years here in Chicago. His present rig was built six years ago and he does very little experimenting with it. He is a studio engineer in the Chicago office. Due to building a new home Webster will be off the air for several months but we may expect to hear W9JIR on again in the Fall. He is another rabid photographer and spends quite a bit of his spare time trying to get enough fish to pay for his license fee.

Eichorst is our shining example here in Chicago as he is a phone man *par-excellance*. W9RUK has been one of the most widely heard phone stations in the world on the ten and twenty meter bands. "Ike" has a home located on a knoll and the array of antennae radiating therefrom would make the boys from Riverhead hang their heads in shame. He has no use for CW and seldom uses it. He is a control relief man here at NBC and is on the early morning trick.

We suspect that he likes this early trick for it is rumored that he gets up early and keeps his schedules with the "Aussies." He is noted for his bright and peppy looks early in the morning after a strenuous night of DXing.

There are several other active "hams" here in Chicago and we hope to tell of them in later columns of the Journal. We hope to have more of them on this Fall and Winter and possibly we can have a phone network along with the CW network. We have enjoyed talking to the other men on the network and hope that the friendships created will be long and lasting.

## RUMOR AND GOSSIP

continued from page 6

cent issues of QST for specific circuits and arrangements to insure safety. An evening of your time thus spent may save a life. Switch To Safety;—NOW!

According to recent QST Correspondence, there seems to be some legitimate feeling against the recent crop of BC receivers, to the extent of recommending repairs to old, well engineered receivers, in preference to recommending of a questionable "1939 Model" in a super-gloss cabinet. The gripes center around the lack of preselection and susceptibility to ham QRM. Quoting an FCC Inspector on the subject, "The mark of a good receiver isn't in what it will bring in, but in what it will leave out."

If the originator of the term "Telecast" is still around and willing to admit it, refer him to QST's August 1939 Editorial on the subject, which is a bit too long to quote here.

Newly amended Constitution and By-Laws of ARRL are available to members on request.

Understand McNinch resigned as FCC Chairman.

Wonder why some influential manufacturers, having vital interests in foreign markets, don't put some legitimate pressure on those public officials interested in recovery, in order to get the high frequency broadcast bands, facsimile, and television channels converted from their present "experimental" status to "commercial" status? It seems a simple matter to prove thru a barrage of technical experts, that these arts have long since passed out of the dark ages of the truly "experimental" status.

Broadcasters are required every six months to show that they serve in the public interest, convenience, and necessity; so far the idea seems to have worked as well as any political control can be expected to work. However, following the idea further, why wouldn't it be for the general good to have every public employee give a public accounting, at his own expense and time, of his activities for each six months period, indicating how he has served in the public interest, convenience, and necessity?

Switch To Safety!—NOW! From the NY Daily News of August 7, we read of a worker who was electrocuted when he touched an electric grinder with one hand and rested the other on the metal frame of a window. Switch To Safety—NOW! Don't leave anything floating; ground frames of rotating machines, transformers, and chokes—NOW!

FLASH! (Is it still legal to say 'Flash' after the kiddies' bedtime?) ATE Television Cameramen Make History! The history. After three consecutive months of live talent public First Annual Convention of Television Cameramen passes into television service, Studio 3H shut down for four weeks to allow the technical staff to clean up their vacations. The technical staff and studio equipment withstood the driving strain of forty hours service per week without a single service interruption or man-failure. The Convention voted a moment of silence in recognition of the untiring service of Ray Monfort, Television Maintenance "Bag-holder," and his hand-picked staff of "Silent Workers." Charter members are Cameramen Burrell, Stolzenberger, and Conn. Burrell missed only one show, due to "restaurant stomach," and was relieved by our photographic authority "General Sherman" Davis, whose appreciation of the cameramen's problems was lauded by the Convention. Stolzenberger finished the program service period with a 100% record, active in every show, and became the senior cameraman with the announcement of Burrell's transfer to the Mobile Unit. Conn. transferred from the Fair Exhibit, filled out the last few weeks of program service when Thatcher was relieved as Cameraman and was transferred to the 9th floor Radio City Jeep. The Convention unanimously approved their aluminum-

sprayed helmets as necessary to maintain health and disposition. For the benefit of those unfamiliar with the problem, a cameraman is frequently maneuvered into a position where he is "taking" several times more light and heat than the cast in the show. The Convention designated the cameramen's official pasttime as, "Who's in the Control Booth?" which can be appreciated only by the initiated! It was agreed that being a Television Cameraman develops the patience and diplomacy of the individual in a unique manner, and should be a line assignment for diplomatic service aspirants. The technical side of the Convention considered such questions as: What constitutes good composition; Dynamic versus static symmetry; Closeup versus long-shot brightness; Centering the main character versus centering the group, when the main character is part of that group; The near-future of television, etc. Much important discussion centered around the relative importance of the movie cameraman versus the television cameraman; you must have read some of the publicity given out about the relative unimportance of cameramen in television; the man in the street cannot be expected to know the facts, but you can't fool the man who has successfully handled a television camera! Television cameramen must make decisions on the spot: when the PL cue-circuit fails; when one of the cameras goes into trouble and the remaining two cameramen are on their own to make up the shots of the defective camera; when the cast assumes a position greatly different from that in rehearsal; when a dance act forgets their bounds and gets into the area of offset and floor lights; when the first time you see an act is on the "Dress" or "On-the-air" as happens occasionally; when the producer changes his mind between Dress and On-the-air, and adds, deletes, or changes your shots or routine; when camera, mike-boom, and/or floor lights get into a snarl, especially during "unrehearsed" transitions between the acts or parts of the show; and there are more. The Convention did not go into a good cry over this, but it would be helpful if the Press, Critics?, and especially our ATE were made familiar with the conditions. The business of technical television publicity being released to the press by production-men, and other non-engineering personnel was mentioned as giving the semi-technical public a reason to haw-haw; why shouldn't members of other departments be restricted in the same way the Engineering Dept. personnel are, in regard to statements to the press; and further, why shouldn't they be restricted to making comments about their own department? Everything discussed was in the best interests of Television, and with a view to improving and furthering Television. The Convention was voted a huge success, and at the close of business, the Cameramen drank a toast to the betterment of the status of Television Cameraman, and adjourned "The First National Convention of Television



Cameramen." In the adjacent photo are, left to right, Television Cameramen Burrell, Stolzenberger, and Conn, looking a bit

worn after the Convention. (Passport-photo by Haussler!)

Mrs. "ED" and I were intrigued by newspaper stories of automobiles coasting UP-hill in the town of Leominster, Mass. The vacation was at hand, so opened the file cabinet and got out one of last year's maps, and located the town. Packed a nine-inch spirit level, a good compass, a camera, a rubber ball, a few marbles, and Junior; at the end of 225 miles, we were in the town of Leominster. Looked up the famous Lowe Street and located the mystery part of the road with the aid of native motorists. There was no doubt of the grade—to the eye, yet when releasing the brakes, the Chevvy rolled about sixty feet and got up to about six miles per hour. Repeated this several times, once letting the Chevvy roll "up the hill" backwards—just to make sure. Due to the coarseness of the pavement, it was impossible to make a check with the marbles and the ball. The compass acted normal. It was difficult to find an average place on the road to lay the spirit level, due to the nature of the pavement; however, over a dozen checks indicated the road to be level, or actually very slightly up-hill—(1/16 inch rise in nine inches.) Yearned for a transit to accurately determine the grade—it's very convincing to the eye—but will have to wait until a construction project takes Gordon Strang up this way. We left Leominster at 2 PM Saturday afternoon, feeling that the expedition was justified and entertaining. Heading for Ausable Chasm via Ticonderoga, NY, we got as far as Fair Haven, Vermont, and decided to stop for the night; took Junior for a walk in the sunset, and turned in early in order to get an early start in the morning. Sunday morning, driving thru the Adirondack State Park, 6:30 AM, 50 m.p.h., comfortable speed, the "soup" is rising out of the valley—heading for the town of Ticonderoga, and breakfast—only 3 miles to go now—going down one of those mile long mountain grades featuring lakes and deluxe scenery—suddenly and without warning, a succession of sharp, deafening, staccato thuds seemingly under the front seat—subconsciously dropped into neutral gear, cut ignition and continued down the grade around the turn, nothing in sight but trees, mountains, and yes! a gas pump!—but it's 7 AM Sunday morning, an unfriendly hour to awaken a stranger. In the best NBC Maintenance tradition, decided to look under the hood cover before hitting the starter in a process of elimination—lifted the hood—generator conspicuously hanging by the fan belt at a crazy angle—a chunk of iron laying against the inboard side of the generator—a jagged hole about 30 square inches in the side of the motor block with a mangled piston rod sticking thru the gaping hole. A sickening sight. The old gent living next to the gas pump was awake and phoned the Chevvy dealer in Ticonderoga, who arrived promptly and pushed us 2.7 miles into town. Left the "crate" at the dealer's garage, and had breakfast—finally. After breakfast, got down to business, and learned that new blocks cost \$88, and must be shipped from Long Island City—the irony of it, 8 miles from home! Then learned that the Parts Dept. closes over the weekend and that there would be nothing gained in sending the telegram for the block before 8 AM Monday, and that it would take until Tuesday noon until the block arrived by express, and it would be sometime Wednesday until we could leave town. Since we were going to be in town for several days instead of just passing thru to get breakfast, we put up at one of the Tourist Homes on the hill near the New York State Historical Society's Museum. After lunch, trekked three long, weary miles over hot, county roads, the hot August sun beating down upon us, until we reached famous old Fort Ticonderoga, where some of the original trenches are still plainly identified. Rested our feet before walking another mile around the Fort—Junior was giving us some trouble, and had to be bought

off with a bottle of pop every mile. The three mile hoof back to town was not so bad, mostly downhill, and Old Sol had been kind to stay behind a heavy cloud. Needless to say, we slept well after that walk. Up early Monday morning to see that telegram off at 8 AM, and double checked the Chevvy cipher for "Rush-Express." Nothing to do now till Tuesday noon, so spent the remainder of Monday walking around town getting acquainted; the population is 5,100, we counted ten eating places including two hotel dining rooms, but exclusive of several Tourist Homes that served meals; the person that named Brooklyn the "City of Churches" never saw Ticonderoga! Six Churches—Baptist, Christian Science, Congregational, Episcopal, Methodist, and Roman Catholic, (alphabetically) and an active Mission, meeting every evening at 5:30 PM; from external appearance the Roman Catholic Church was the most prosperous, the Christian Science Church looked the poorest, but not poverty stricken. Observed much fraternal activity; the Odd Fellows had a snazzy building of their own, the Knights of Columbus and Elks were housed in adjacent commercial buildings. Posters around town announced a Townsend Old Age meeting for tonight; intended to go to meeting, but got tied up with some swell fried chicken; got down to town in time to pick up the gossip of those leaving the meeting—they seemed to agree that "it sounded logical," "why not?" (We had previously noticed posters in Vermont announcing these Townsend Old Age meetings.) Spent Tuesday morning visiting the NY State Historical Society's Museum. Tuesday noon arrived, and no motor block—the garage now says it might take another day to get here—so decided to do some more walking; followed the creek that joins Lake George with Lake Champlain; walked about two of the three miles toward Lake George when the wife and Junior ganged up on me and staged a sit-down strike, so we didn't get to the lake. This creek is dammed at five places to handle the 160 foot difference in level between the two lakes. Wednesday morning, decided to take a tour thru the Ticonderoga Pulp and Paper Company which gets its power from this creek. Had a most interesting tour behind the scenes; this plant turns out high grade magazine paper, which starts out as poplar logs, which are chipped, cooked, and again chemically cooked until it looks like boiled rice, but feels like wet cotton wadding. It is then flowed wet onto a moving belt where the water is removed, the paper to be is then heat-dried after which the sizing is sprayed on the surface of the paper. (The old method mixed the size during the cooking process, which is wasteful.) Surplus size is drained off, the paper again heat-dried, and loosely rolled with edge markers indicating tears or other imperfections, which are removed or corrected when the roll is later tightly rolled for shipping. Got to know two assessors of the State Tax Dep't. and learned that the Conservation Dep't. requires the Paper Company to maintain the level of Lake George plus or minus six inches thruout the year. Sounds as though it would be easier to buy power wholesale, when considering winter ice-jams and spring floods, and curtailed operations enforced by the present drought. However, visit the plant when you get up this way, it's well worth the hour or so; there is no admission charge. It is now Wednesday noon, the Chevvy dealer shakes his head,—no block yet; investigated at the Express and Freight Offices, and learned nothing except that the next train would arrive in twenty-four hours! Had previously written my bank for funds to meet this

unexpected expense; the train that should have brought my block, brought me a letter from the bank advising that it was impossible to pay money without the passbook, and a few other formalities. It was now 2 PM, and felt my patience nearing its end. After seven minutes of long-distance telephoning, I succeeded in reversing the banks policy, and in 35 minutes had the Western Union money-order cashed; then long-distanced the Chevy Plant in Long Island City, to learn that they shipped the block by Freight instead of by Express; admitting his error in shipping instructions, he promised to trace the block and let us know when to expect its arrival. No word yet, so at 9:40 PM, packed the wife and Junior into a bus for Albany—after the Ticonderoga dealer agreed to wire us when the Chevy was running again. Around Glens Falls, saw a couple of people mangled up in an auto-motorcycle accident—Junior slept thru this half-hour delay; our bus driver offered his first-aid equipment to the State Police; when we left, there was still no ambulance—they managed to stop a touring MD, who couldn't do much with a few iodine applicators. The wife was upset, so took the train down from Albany to New York City; after a few subways and a bus, we arrived back home in Richmond Hill at 7:30 AM. After a day of rest, phoned the Long Island City Plant Saturday AM, to learn that they gave up tracing the first block, and sent another by Express "which should be there by now." However, I haven't received my telegram yet, and am wondering if I'll get the crate back in service before the 1940 models are out. The only cheerful thing about the whole incident, is that according to the law of averages, I should never lose another motor block.

Mr. Brooke of Hollywood: Your letter to the Journal Staff re: the Bathing Suit Journal cover of several issues back was noted. I invite you to grant permission to quote your letter in full.

Trying to get a last minute scoop on the National Geographic expedition that will take Jon Larson, NYFE, away from New York for one year. Lynn, DE, recovering from divorced appendix. By the time this issue reaches you, you should already know that the CBS ABT has given 60 days notice to CBS to open agreement in order to seek parity with production men, which at that time was \$120. week; since the notice was served the production salary was reduced to \$100; expect that at the expiration of the notice period, production men will be "salaried" at \$25. per week, with some bonus or other "non-salary" arrangement to thwart the boys; past experience indicates they are not too easily thwarted, or fooled. It's interesting to note that the single station WOR employs 50 Engineers, whose Group 2 is only 1% under ours, and whose Groups 4, 5, and 6 are 8% over ours! Someone just remarked that it's time to hear the pre-Convention (ATE) story that "the gross is up, but the net is down!" Just finished reading some Forum Magazine philosophy of 1934, suggesting that workers unionize as mass consumers, rather than hang onto the dwindling demand for the commodity of labor as a basis of unionization. Doesn't look as though the Eng Chapter will have elected a Chairman before the Fall Convention; the NY Chapter recently expressed the opinion that Video workers in NY belonged to the NY Chapter, however, elections now going on in NY Chapter without ballots for the Video boys; it's about time the NY-Eng Chapters got together and straightened out the mess, rather than waste a lot of Convention time—and our money. Hollywood "Wolf" gag in the last issue is as old as 42nd Street. Larson, NYFE, being honorably excused from routine Journal work until his return from Expedition—provided he radios the Journal a few "scoop" stories. FLASH! The NY Chapter certificate of Incorporation has finally arrived!

## DID YOU EVER

by F. C. EVERETT

### DID YOU EVER

Push a voltmeter button (you thought) and find that instead you had pushed

1. The call button to the boss's office
2. Phone button to transmitter
3. Phone button to studio
4. Fire or Police alarm

### DID YOU EVER

Read, ten years after you had written it

1. A love letter to your wife
2. A love letter to a girl not your wife
3. A letter to the editor
4. A technical radio article

### DID YOU EVER

With your camera in hand take a picture that was to be a masterpiece and candid as well, only to find you had failed to

1. Remove the slide
2. Remove the lens cap
3. Insert film
4. Extend the bellows

### DID YOU EVER

Ask for a raise and

1. Not get it
2. Get it
3. Get fired

### DID YOU EVER

Kiss a pretty girl and find that

1. She was a flat tire
2. It was very interesting
3. You had an audience

### DID YOU EVER

Carefully remove the largest and most expensive bottle from the ham transmitter, lay it on the table, have it roll off and

1. Catch it halfway down
2. Not catch it

### DID YOU EVER

Climb to the top of an amateur mast only to find that

1. It was designed poorly
2. The guy wires were too small

### DID YOU EVER

Work frantically to make a transmitter put out, and then eventually find that

1. You were on the dummy antenna
2. The lightning switch was grounded
3. The main power switch was open

### DID YOU EVER

Start to work late on a cold morning, grind frantically with your starter and when the battery was run down find

1. You had forgotten to turn on the ignition
2. You were out of gasoline
3. It was your day off

### DID YOU EVER

Relieve your feeling in language filled with scallops, flourishes, asterisks and exploding stars, only to find the best looking girl in the building right behind you. Then five minutes later hear her raise you five, doubled and redoubled as she encountered some pet irritation

? ? ? ?

## KFI - KECA

by H. M. McDONALD

**AT SIXES AND SEVENS:** With men on vacation, the brushing up of the newly acquired KECA transmitter (ex KEHE), re-designing the Vermont Avenue control rooms and studios (also ex KEHE) for two station operation preparatory to moving out there, longer hours on the air for KECA, many new programs, a new and larger orchestra, et cetera, it was found too difficult to get teams and parties together for sports contests or tournaments of any kind so there will be none of that kind of news for a while. As individuals they continue to practice though and when we get straightened around watch out Hollywood.

**GOLDEN GATE INTERNATIONAL EXPOSITION:** Is it worth going to see everyone asks us upon our return from the e. Definitely YES; don't miss it, and Fall is the best season of the year in San Fran. But don't expect to see it in a day or two; there's enough to keep one going for a week; and it's NOT expensive and there are plenty of accommodations at prices to fit every purse.

**W6XBE:** No trip to Treasure Island is complete without a visit to the G. E. 20 KW international station operating on 9530 and 15330 KC. Harold Yokela, engineer, and Carlos Benedetti, announcer, were on watch and greeted us cordially and showed us everything. No large studios because they do not originate big programs, just talks, news, and sustaining programs from the Red and the Blue fed by NBC from S. F. Fortunately we were there when they signed off on one schedule, shutdown, and re-tuned for the other frequency. Yokela took us inside for a close-up of the newest in high-power short-wave transmitters and it's really somethin'.

**111 SUTTER:** Although we worked in the same block for many years we never got up to NBC's S. F. studios until this vacation. Ran up for a few minutes and met Kilgore, Fullaway, Rothery and O'Neil. Kilgore kindly guided us around the Master Control Room, studios, news-room, and recording. Wonderful view from their 22nd story windows. Their studios seemed small and crowded though, everyone climbing over something. However it was a busy day, 22 originations as compared with Hollywood's 7, someone said. Eddie Wachter, ex Morse wire man there (sined W) is now with S. F. Fire Dept., dispatching.

**RANCHO KPO:** How we laughed when we saw an article titled that way a few months ago. But the laugh is on us; those marsh lands which were half inundated with each high tide when we last saw them, have been diked and drained and within a couple of hundred feet of the transmitter there are enough cattle grazing to furnish material for a dozen rodeos. Barnes conducted us around their "model 50 KW transmitter building", proud as Lucifer, and justly so, for it is conveniently arranged with a place for everything and everything in its place, spick and span and shining. The floor looked as though Harlow Wilcox had just been there. The kitchen was immaculate and the Missus wanted to move right in. Found Ed Manning hunched over a mill in the input room, pounding out a report. He left it long enough to glad-hand us and swap

a couple of stories re early KPO transmitters. We enjoyed our few minutes stop there and hope those boys, as well as all other NBC men, will favor us with a visit when in L. A.

**TELEVISION:** The article in the August issue "Once More Whither Television?" was avidly read here. We especially liked the author's (R. D. Compson?) frank discussion of the 'flops' as well as the successes. Let's have more, RDC, with your name at the top of the article, rather than those two modest initials at the end.

**W6XAO,** the only station regularly broadcasting television programs in this section of the country, have stepped up from 300 to 441 lines but seem to have abandoned studio shows for the present and are showing motion pictures only, one to two hours three nights a week. The picture is good, but the films are barely fair and often repeated a few days later. However the station stresses they are "for experimental purposes only."

We have just received an RCA Model TRK-12, combined broadcast, short-wave and television receiver and it works like a charm. However we are only a mile from the television transmitter. We've sent for an RCA di-pole antenna with a reflector and upon receipt the receiver will be moved to another location, about five miles from the transmitter with low hills between, and then we shall see what we shall see.

**JOURNAL COVERS:** We like Bill Eddy's cartoons. Seems to be a counter-part for every one of his subjects in our own station. We're wondering if the subject of the "Sea Hawk" on the cover of the July issue was himself. Curtis Mason, most enthusiastic of the many yachtsmen here, saw an article in "Rudder" by Eddy re his recent acquisition of a cruiser, more or less in need of a few (?) repairs, probably those illustrated, plus.

**ZIP:** Since Alexander received his 1940 Packard he's the most sought-after man in the organization; everybody quizzing him and begging a ride. Alex's enthusiasm over the new Six only serves to rile up the other four men whose cars haven't been delivered yet.

**RECUPERATING:** Out to see how Ralph Denechaud was getting along after his second operation. Agreeably surprised to find him up and around, fast regaining his strength; probably be back to work by the time this is printed. Has quite an assortment of tobacco pipes and a swell collection of technical books.

**MEYER DASHES BY:** Could have knocked us for a row of 862's when Henry Meyer, genial General Manager of the Journal, phoned us from Hollywood the other day. He's trying to see the whole West on a three weeks' vacation. Stopped here just long enough to glance around. Met he and O'Kelly and chatted with them over light refreshments for a few minutes before Meyer's train time. Easy to see why everyone speaks well of both of them. Come again Henry and spend more time so we can show you around from where Jake left off.



Let the RCA 96-A Limiting Amplifier help you answer

**YES!**

It has been effectively demonstrated that the RCA 96-A Limiting Amplifier will permit you to increase the signal strength by 3 db—about the same thing as doubling the power of your transmitter.

The 96-A enables you to get an increased signal without making your transmission sound distorted. This is because of the return time constant of the instrument—not fast enough to influence audio frequency tones. Its action depends upon vacuum tubes—easily replaced when necessary. It has been carefully engineered and includes many features the engineer will find useful. The price is reasonable, too.

Why not install an RCA Limiting Amplifier now—when maximum signals are needed to overcome summer static. Write the nearest office for complete details.

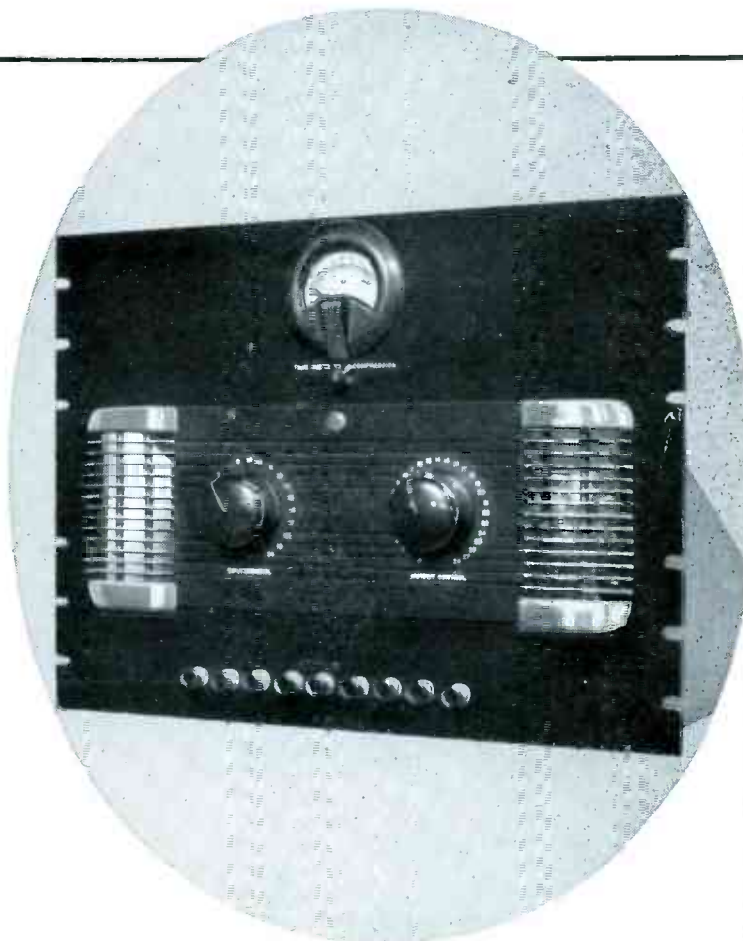

*Be sure of reliable service—use RCA tubes*



*Broadcast Equipment*

RCA MANUFACTURING CO., INC., CAMDEN, N. J. • A Service of the Radio Corporation of America

New York: 1270 Sixth Ave. • Chicago: 589 E. Illinois St. • Atlanta: 490 Peachtree St., N.E. • Dallas: Santa Fe Building • San Francisco: 170 Ninth St. • Hollywood: 1016 N. Sycamore Ave.

2618

# 4 REASONS WHY...

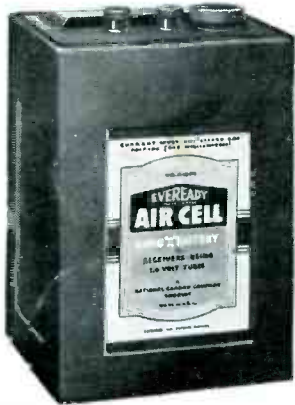

**A-1300**  
Expressly built for the 1.4-volt tube.  
Guaranteed capacity 300 ampere hours.



**A-2300**  
Expressly built for the 2-volt tube.  
Guaranteed capacity 300 ampere hours.



**A-2600**  
Expressly built for the 2-volt tube.  
Guaranteed capacity 600 ampere hours.

THE "EVEREADY"

"AIR CELL"

RADIO "A" BATTERY

is the engineer's choice!

- 1.** It gives *level power* throughout its guaranteed life—can't burn out tubes when new, and won't cause *fading* up to its last service hour!
- 2.** *No recharging!* The "Air Cell" battery is a patented, exclusive "Eveready" product. Comes dry, hermetically sealed, no shelf depreciation. *Its "life" begins when water is added!*
- 3.** *Less costly!* These batteries have a *guaranteed* capacity of 300 and 600 ampere hours at two voltages—one for 1.4-volt tubes, one for 2-volt tubes.
- 4.** It is the *ideal* battery for a wide variety of engineering, research and experimental applications!

**NATIONAL CARBON CO., INC.**

General Offices: New York, N. Y. Branches: Chicago, San Francisco  
Unit of Union Carbide  and Carbon Corporation

The words "Eveready" and "Air Cell" are registered trade-marks identifying products of National Carbon Company, Inc.