

Radio Editors of magazines and newspapers are hereby given permission to reprint in whole or in part, with proper credit to the Aerovox Corporation, the contents of this issue of the *Aerovox Research Worker*.

The AEROVOX

Research Worker

The *Aerovox Research Worker* is a monthly house organ of the Aerovox Corporation. It is published to bring to the Radio Experimenter and Engineer authoritative, first hand information on capacitors and resistances for radio work.

VOL. 18, NO. 10

NOVEMBER, 1946

50c per year in U.S.A.
60c per year in Canada

HIGH-FREQUENCY ANTENNAE

By the Engineering Department, Aerovox Corporation

The accompanying drawings give the configurations and proportions of common types of high-frequency antennae. These types are employed also at ultra-high frequencies. The antennae illustrated in Figures 7, 8, 11, 12, 13, 14, and 15 are highly directional in operation. At ultra-high frequencies, it is comparatively easy to arrange the latter for rotation in order to transmit and receive in desired directions. The directional effects of the antennae shown in Figures 2 and 5 are very slight, and virtually no directional effects whatever are noted with the types shown in Figures 1, 3, 4, and 6.

Coaxially-Fed Doublet. Figure 1. This antenna is simple to erect and operate. The radiator is a single half-wave in length. (The length in inches of a half wave section of wire or tubing in the ultra-high-frequency region is equal to 5540 divided by the frequency in megacycles). This half-wavelength does not include the length of the insulator which must be installed at the center of the radiator. The feeder consists of any length of low-loss coaxial line attached to the broken center of the radiator. At the bottom end of the feeder is a connection to a one- or two-turn coil which is link-coupled to the transmitter tank.

Delta-Type Matched Impedance. Figure 2. The 600-ohm line usually consists of No. 12 wires spaced 6 in-

ches apart. Dimension A (in feet) = $148/\text{Frequency (Mc.)}$ B = $123/\text{Freq. (Mc.)}$.

Vertical Doublet. Figure 3. This antenna is straightforward, and is identical with the horizontal doublet of the same type used at lower frequencies. It is imperative that the tuned 600-ohm feeders be brought straight away from the antenna (that is, horizontal) for a distance of at least $\frac{1}{2}$ wavelength.

Coaxial Antenna. Figure 4. This is a vertical type that is meeting with favor among communications stations requiring good local area coverage and low-angle radiation. The metal sleeve is large enough in diameter to clear the coaxial cable amply.

Voltage-Fed Half-Wave Vertical. Figure 5. This is a simple, effective system. However, it is not widely employed because the tuned circuit must be installed at the base of the antenna whose height is apt to make it difficult to retune the system. The tuned circuit also must be protected from the effects of weather.

Mobile Quarter-Wave Vertical. Figure 6. This type finds frequent application in automobile and small boat service. The tuning capacitor usually has a maximum value between 30 and 50 mfd.

"V" and Rhombic. Figures 7 and 8. These types are effective both for transmitting and receiving, but have

not been widely employed at lower frequencies because of the large space required for their erection. The dimensions, however, are reduced considerably for ultra-high frequencies. Dimensions given in Figures 7 and 8 are representative, but are not restrictive.

"J" Antenna. Figure 9. This is a half-wave vertical radiator with quarter-wave matching section.

Ground Plane Antenna. The outstanding characteristic of this type is low-angle radiation and broadcast coverage. Each horizontal element is $\frac{1}{2}$ wavelength in size. The vertical member likewise is $\frac{1}{2}$ wavelength, but $\frac{1}{2}$ wavelength is within the large-diameter metal sleeve. All elements are mounted at 90 degrees with respect to each other.

Directive Types. Figures 11, 12, 13, 14, and 15. These types utilize various means to obtain directivity. Metal reflectors are employed in Figure 11. The parabola and bent sheet need not be of sheet metal, unless desired — they may be made up of vertical metal rods, unconnected, and spaced closely. Figure 12 shows a driven radiator operated in conjunction with parasitically-excited reflector and director. The arrays shown in Figures 13, 14, and 15, on the other hand, are made entirely of driven elements, excited in the proper phase by transposition of the feeder system.

AEROVOX PRODUCTS ARE BUILT BETTER

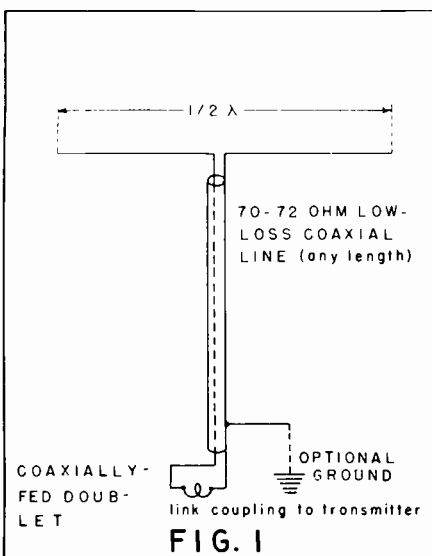

FIG. 1

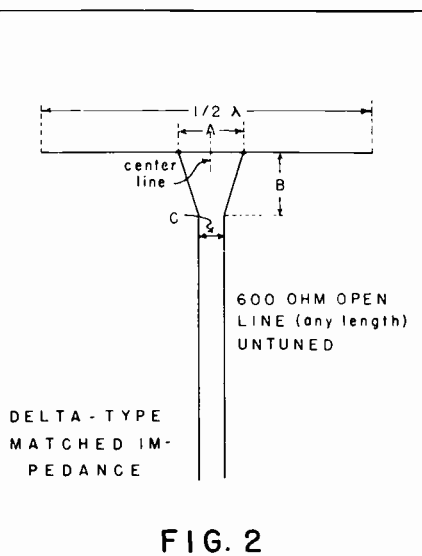

FIG. 2

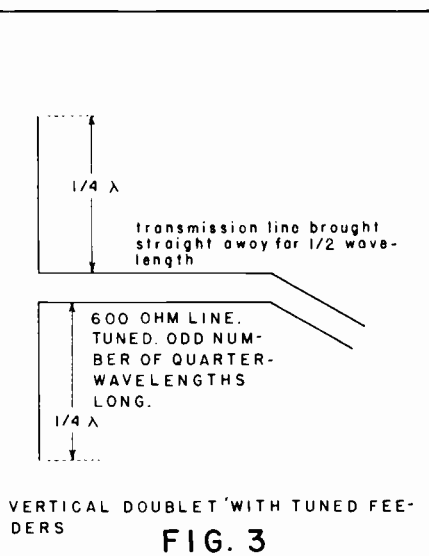

FIG. 3

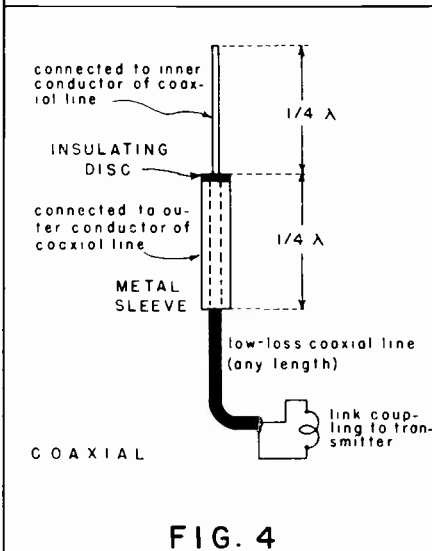

FIG. 4

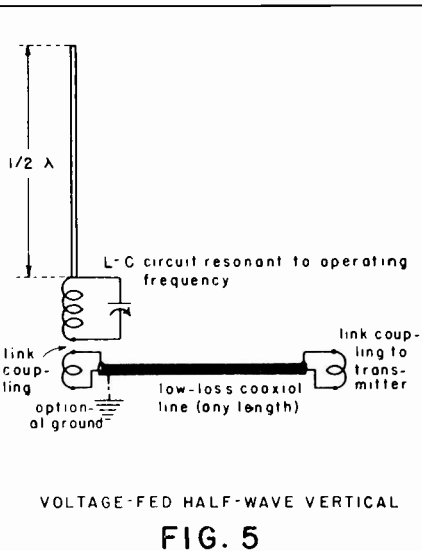

FIG. 5

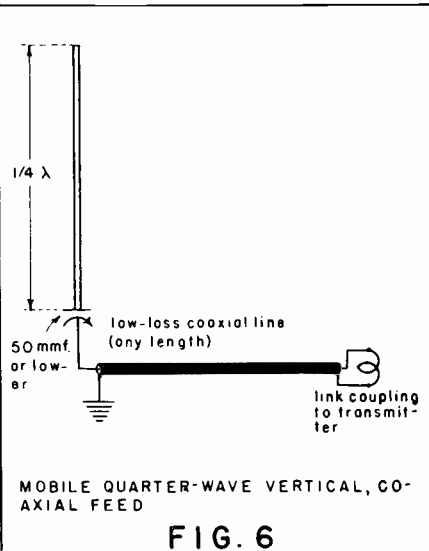

FIG. 6

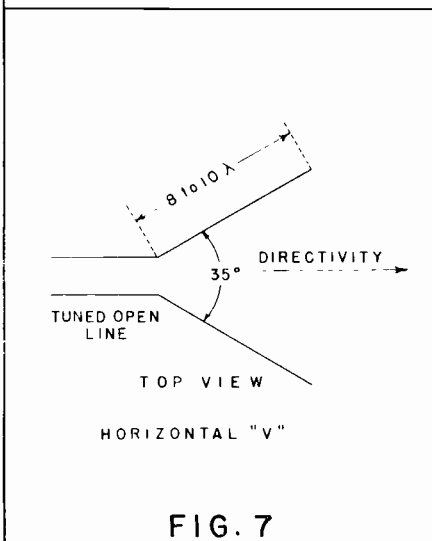

FIG. 7

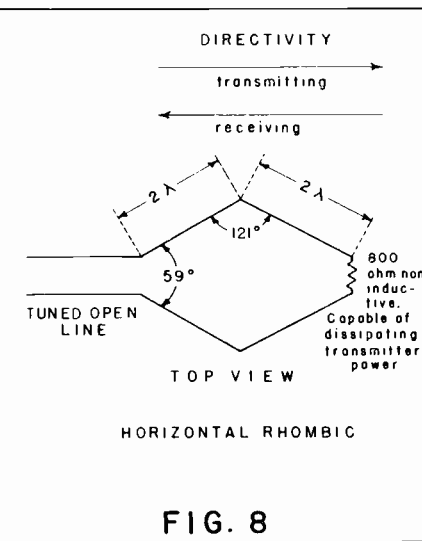

FIG. 8

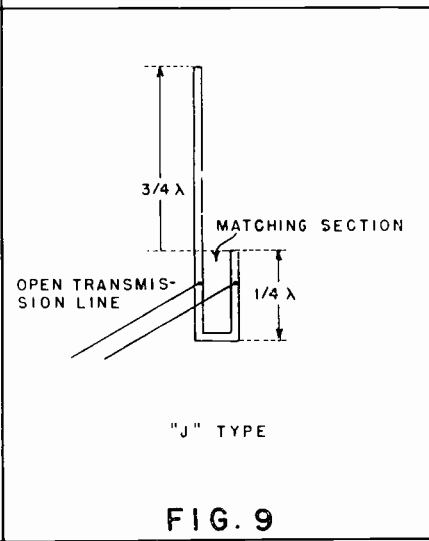
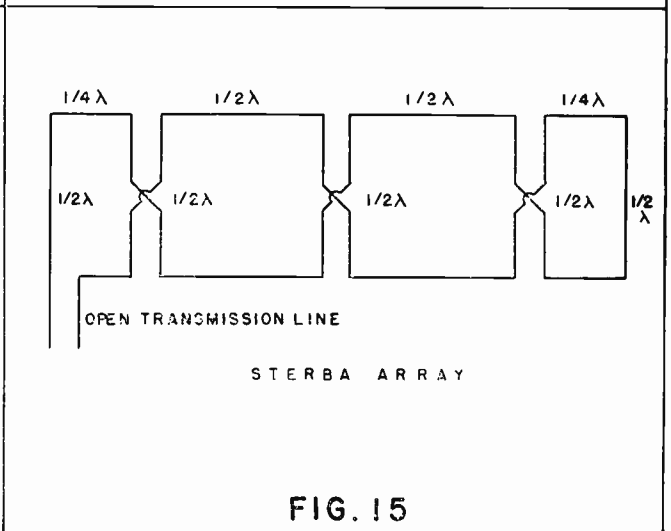
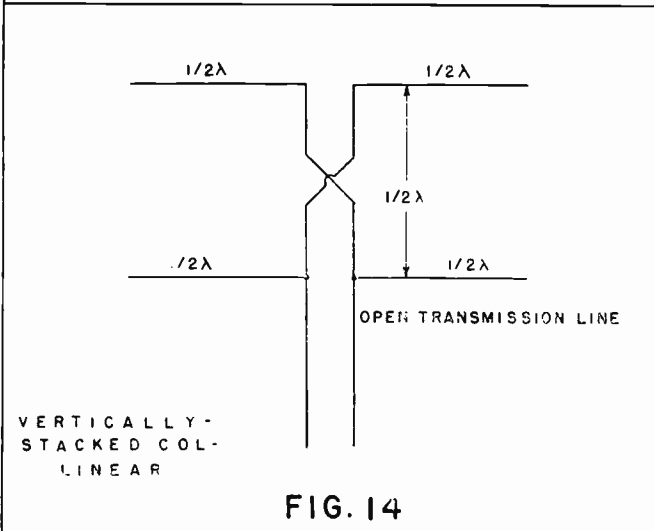
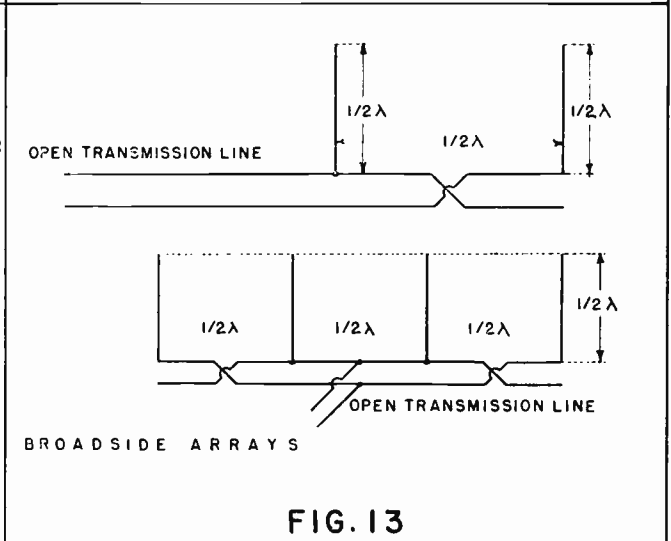
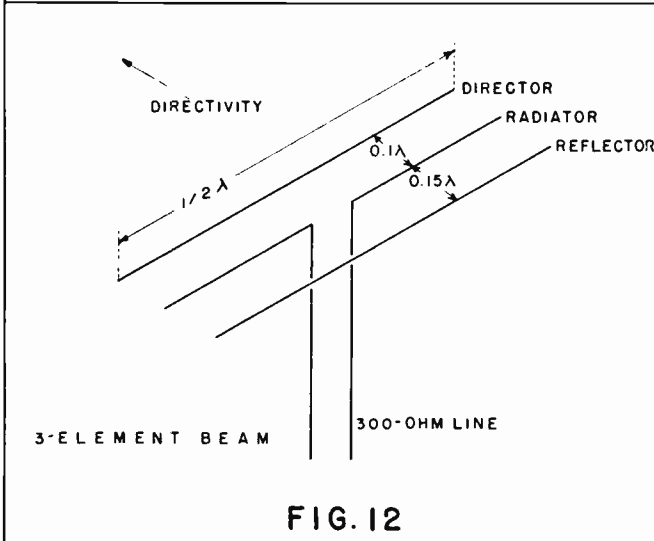
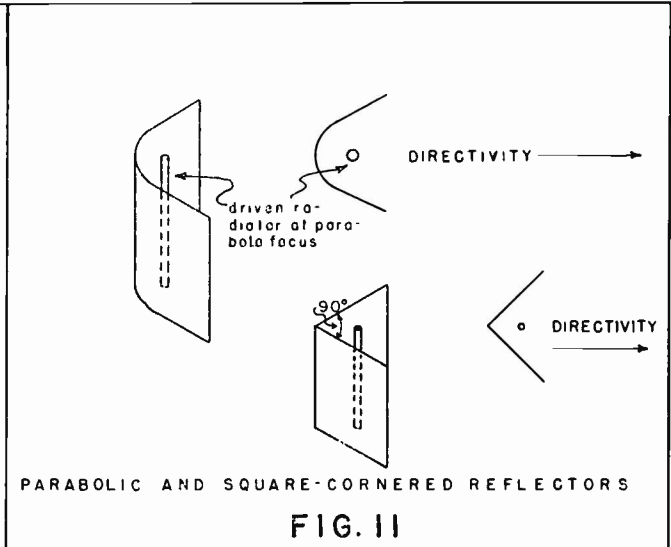
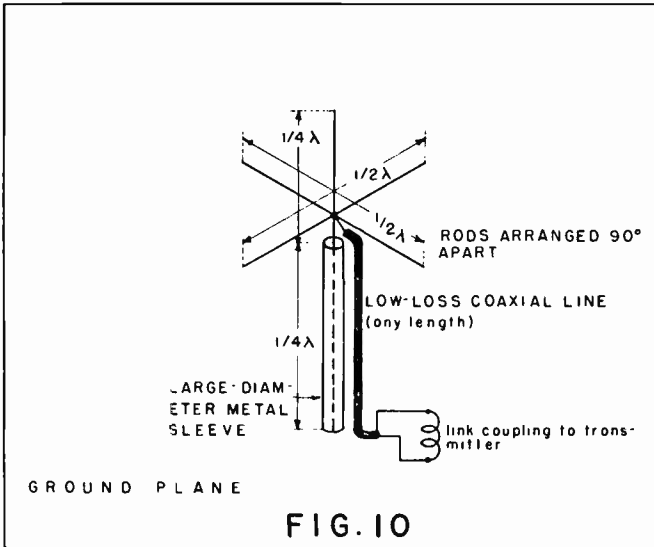
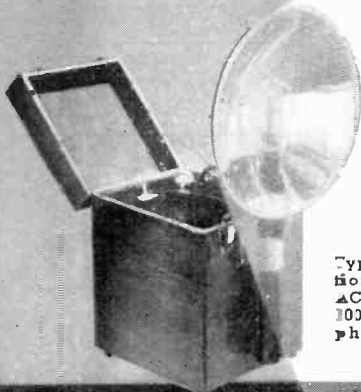
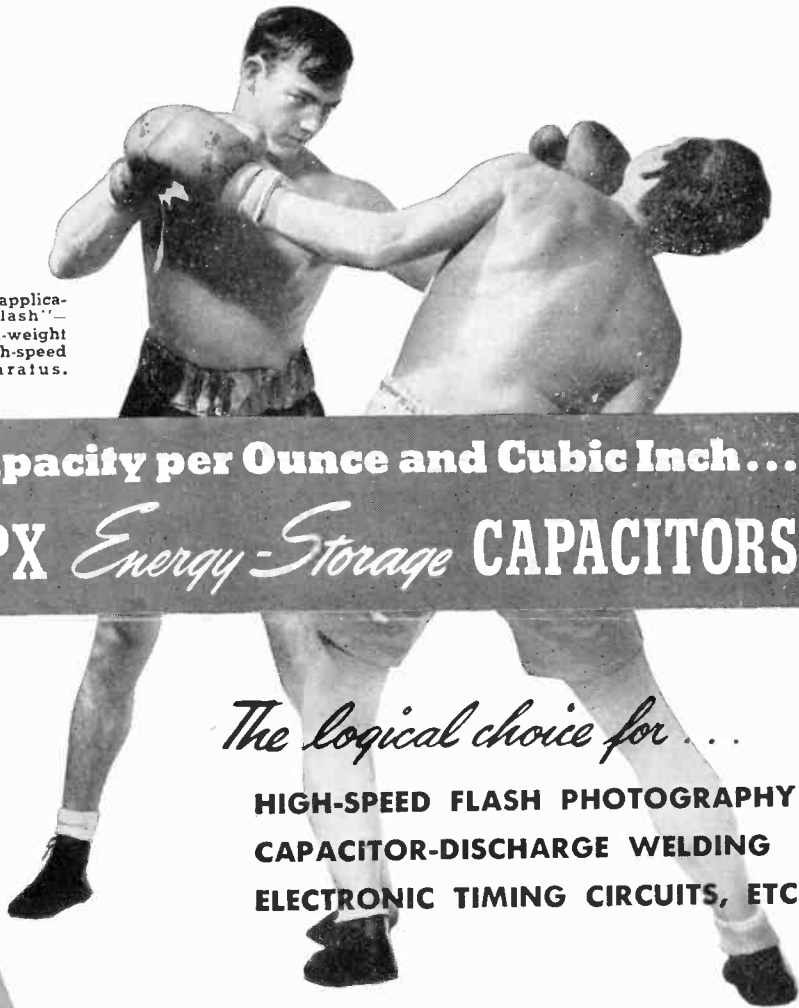

FIG. 9





Typical discharge application—the "Syncroflash"—AC operated light-weight 100-watt-second high-speed photo-flash apparatus.



Maximum Storage Capacity per Ounce and Cubic Inch...

AEROVOX SERIES PX *Energy-Storage* CAPACITORS

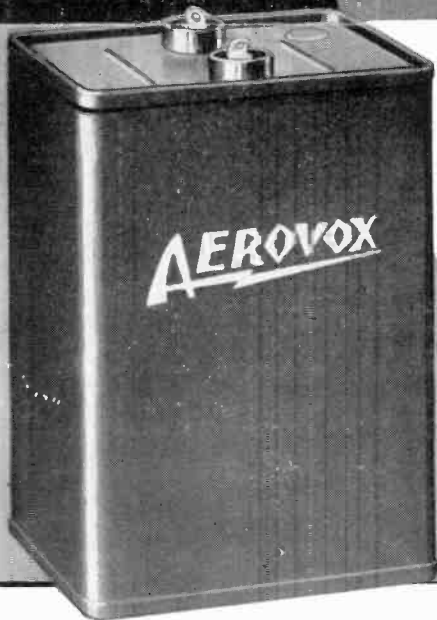

12.5 mid. 4000 volt DC peak Hyvol Energy-Storage Capacitor.

The logical choice for...

**HIGH-SPEED FLASH PHOTOGRAPHY
CAPACITOR-DISCHARGE WELDING
ELECTRONIC TIMING CIRCUITS, ETC.**

• Interested in storing a large amount of energy in a small space—and at low cost, first and last?

If so, Aerovox Series PX Energy-Storage Capacitors are your logical choice. Here's why:

Light. Fast discharge. Easily installed. Exceptionally rugged mechanically and electrically. Time-proven Hyvol impregnant and fill for the generously-proportioned paper-and-foil sections, insures dependable service and longest life. Positively the maximum energy-storage with minimum bulk and weight.

Preferred ratings available for prompt delivery, are listed at left. Other ratings can be designed and made to order for exceptional requirements.

• Our engineers will gladly discuss the advantages of Aerovox Energy-Storage Capacitors as applied to your specific problems or needs.

**ENERGY STORAGE* CAPACITORS
PREFERRED RATINGS**

WATTS-SECONDS	VOLTS - E	TYPE NO.	DIMENSIONS HT.	WT. LBS.
22.5	1.5 KVDC peak	PX10F1	2½ x 3¾ x 4½	2¾
50	1.8 " "	PX13D1	4-9/16 x 3¾ x 4½	4¾
50	2.0 " "	PX14D2	4-9/16 x 3¾ x 4½	4¾
100	2.5 " "	PX15D1	4-9/16 x 3¾ x 6½	6½
75	3.0 " "	PX18D1	4-9/16 x 3¾ x 4½	4¾
550	3.0 " "	PX22F1	5½ x 13½ x 13	App. 64
100	4.0 " "	PX20D1	4-9/16 x 3¾ x 4½	4¾
500	4.0 " "	PX32F1	5½ x 13½ x 13	63

*Stored Energy = ½ CE² Watts-Seconds (C in farads)



**FOR RADIO-ELECTRONIC AND
INDUSTRIAL APPLICATIONS**

AEROVOX CORPORATION, NEW BEDFORD, MASS., U.S.A.

SALES OFFICES IN ALL PRINCIPAL CITIES • Export: 13 E. 40th St., NEW YORK 16, N. Y.

Cable: 'ARLAB' • In Canada: AEROVOX CANADA LTD., HAMILTON, ONT.