

Radio Editors of magazines and newspapers are hereby given permission to reprint in whole or in part, with proper credit to the Aerovox Corporation, the contents of this issue of the Aerovox Research Worker.

# The AEROVOX

## Research Worker

The Aerovox Research Worker is a monthly house organ of the Aerovox Corporation. It is published to bring to the Radio Experimenter and Engineer authoritative, first hand information on condensers and resistances for radio work.

VOL. 9, NOS. 10 and 11

OCTOBER - NOVEMBER, 1937

50c per year in U.S.A.  
60c per year in Canada

## RADIO RECEIVER POWER SUPPLIES

### PART II

By the Engineering Department

# AEROVOX

Corporation



Part I of this paper was published in the combined August-September issues of the Research Worker.

## AEROVOX PRODUCTS ARE BUILT BETTER

# POWER SUPPLY DEMONSTRATION PANELS

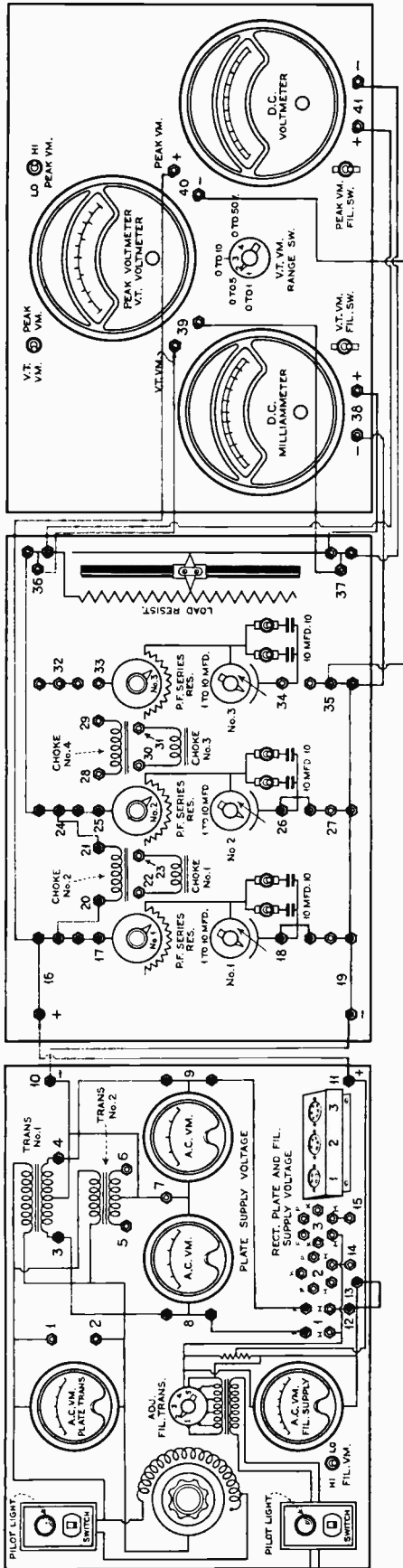

FIG. 13

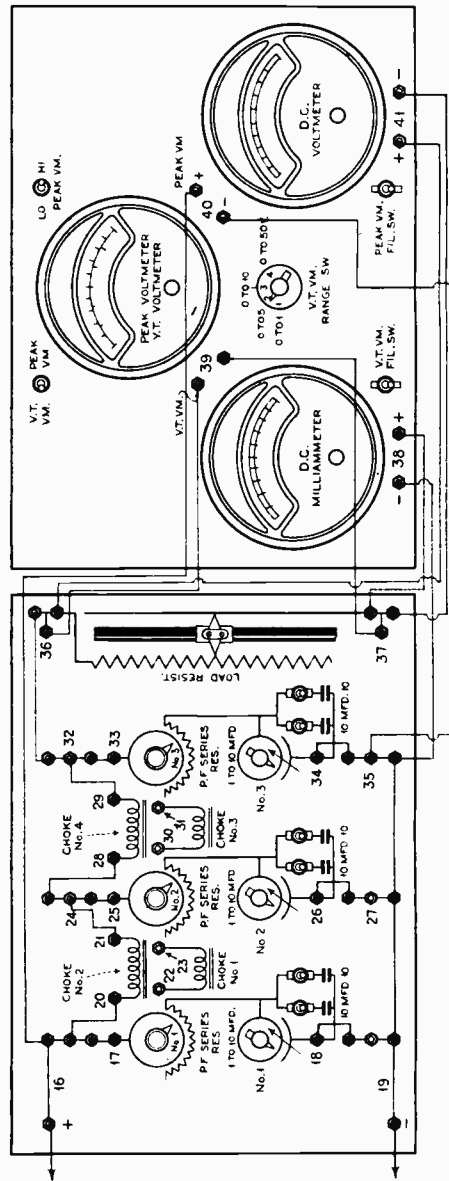

FIG. 14

Above shows the power supply panel, filter panel—arranged for testing a single section condenser input filter circuit; and the instrument panel.

At the right are the filter and instrument panels arranged for testing characteristics of two section choke or condenser input type filters. Red wiring indicates external connections made up by means of patch-cords and plugs.

# RADIO RECEIVER POWER SUPPLIES

## Part II

**T**O demonstrate practically the various conditions that may exist in a typical receiver power supply such as found in the average receiver, we have constructed a three unit demonstration set. This demonstration set consists of a power supply unit containing two plate transformers, a universal filament transformer, and a number of sockets so that any of the current type rectifier tubes may be inserted, as shown in Figures 13 and 14. These units are not permanently wired together but may be connected by the means of plugs and jacks into any rectifier circuit desired. In addition, a Variac is in the primary of the plate supply transformers so that the input voltage to the plate supply transformer may be varied.

The second unit consists of four choke coils and three groups of condensers with a series resistance for varying the power factor of the condenser and a load resistance. With this arrangement, it is possible to set up any type of filter circuit with various values of inductance, capacity, and resistance. It is also possible to use two different types of choke coils, one having adequate core and copper, the other being of skimpy design.

The third unit consists of a DC voltmeter, 0 to 1000 volts, a DC milliammeter, and a vacuum tube voltmeter for reading peak voltages to 1000 volts and RMS values of the AC component of the output voltage. In addition, a five inch cathode-ray oscilloscope is available so that the current or voltage wave shapes in any part of the circuit may be shown.

To show the versatility of the set and to illustrate the various conditions that may arise in typical filter circuits and power supply circuits, a number of experiments were performed in the laboratory, the results of which are given in this paper. The following experiments were all performed on the full wave rectifier using a 5Z3 tube. The first experiment was performed to determine the variation in the output ripple voltage of a single section capacity input filter using one inductance, as the capacity of the condenser is varied. The apparatus was set up as shown in Figure 13 and the results are plotted in Figure 15. As seen from these curves, the ripple voltage varies with the load current. The data obtained in this experiment was replotted as shown in Figure 16 to show the effect of condenser size on the output ripple. It will be noted from the curves on Figure 16, that the ripple volt-

age decreases rapidly with an increase in capacity and that the ripple voltage becomes practically constant and independent of the load current for capacities greater than 16 mfd. For low currents of the order of 40 milliamperes, a condenser of 8 mfd. is more than adequate. There is nothing to be gained by the use of larger condensers in the full wave rectifier circuit as the increase in output voltage, as shown by Figure 25, is negligible for capacities greater than 8 mfd., and the peak plate current increases rapidly with larger condensers.

The decrease in ripple voltage is inversely proportional to the product of the choke inductance and the output capacity of the filter. In addition, the ripple input to the filter decreases with an increased capacity. However, as noted above, there is very little improvement for condensers greater than

16 mfd., in fact, the increased plate current may be detrimental as it materially decreases the life of the rectifier tube. The output voltage is a function of the filter input condenser. The decrease in output voltage with increased load is caused by the voltage drop in the inductance and the decrease in the average voltage across the first condenser as the discharge rate of the condenser is increased by the larger load. This also causes an increased ripple voltage to appear at the filter input terminals. In addition, it is possible that the choke be operated at such values of load current so as to saturate the iron core and thus decrease the effective inductance of the choke. This decrease in inductance reduces the filter attenuation and thus allows a larger ripple voltage to appear in the output. Moreover, the magnetizing current of the

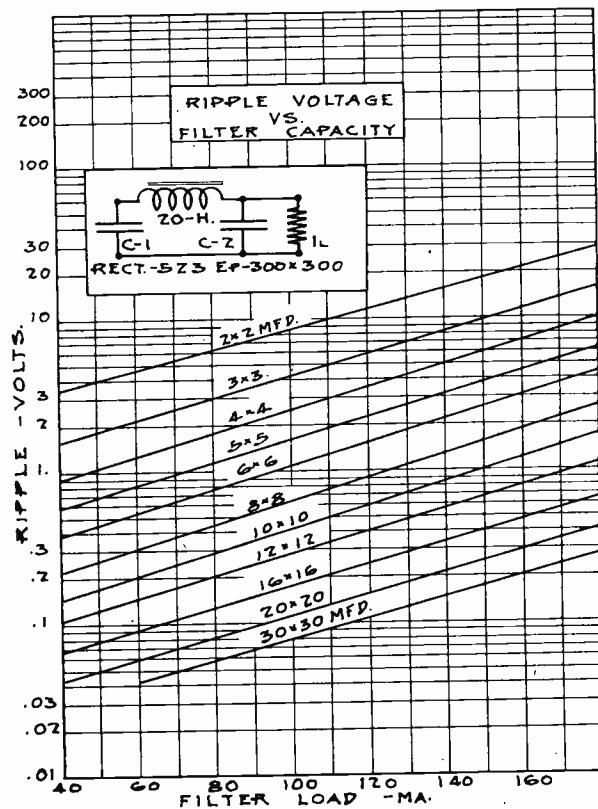

FIG. 15

choke coil increases very rapidly as the iron of the core becomes saturated thus producing an added AC voltage which appears in the output.

The maximum possible ripple voltage which can be tolerated is not easily determined as it depends on the type of receiver, the type of speaker, its low frequency response characteristics, the shape and size of the baffle in which the speaker is mounted, and the overall frequency characteristic of the audio channel. For high quality receivers and amplifiers, the hum output of the speaker should be about 40 to 60 DB below the average output. For less critical receivers, a hum level of about 30 DB can be tolerated. It should be noted that for receivers using a push-pull output stage, a larger percentage ripple voltage may be tolerated in the output stage as the ripple components are cancelled in the plate transformer. Therefore, it is possible to take the plate supply for the push-pull output stage from a relatively simple filter, such as the speaker coil and one condenser, allowing the second filter section to be much smaller. In general, we may say that the ripple output voltage of a high quality rectifier unit should not exceed one tenth of 1% or about 3/10 of a volt for a 300 volt unit. This may be obtained from a single section filter using a 10 x 10 mfd. condenser. For the average small type of set where a ripple voltage of 1/2 of 1%

is allowable, a 6 x 6 or 8 x 8 mfd. condenser may be used. In the smallest size midgets, whose speakers are so small that the low frequency cutoff is well beyond 120 cycles per second, even smaller and cheaper filters may be used. For extremely good filtering, the filter sections may be cascaded and where this is done, the ripple voltage decreases inversely as the nth power of the number of filter sections. With such an arrangement, care must be taken that the filter sections do not act as the two quarter wave units in series, as the voltage rises rapidly at the center point of the filter as this condition is approached. The graphs of Figure 17 show what may be expected from a single and two section filter.

Experiment number 3 was performed to check the effect of two different types of choke coils on the output voltage and output ripple. Choke number 1 is a poor quality choke having a small core and a few number of turns. Choke number 2 is a high quality choke properly designed and constructed. As noted on the curves of Figure 18, the DC output voltage is the same for both choke coils as their resistance is essentially the same. The ripple voltage however, is markedly different for the two chokes. At low load currents, the ripple voltage is approximately the same, but as the current increases the poor quality choke causes a larger ripple voltage to appear

and at 170 milliamperes the ripple voltage of the poor quality choke is 10 times as great as the ripple voltage for the good quality choke. The output voltage is a function of the filter input condenser. The decrease in output voltage with increased load is caused by the drop in the AC voltage and the decrease in the average voltage across the filter condenser as the discharge rate of the condenser is increased by the larger load. This also causes an increased ripple voltage to appear at the filter input terminals as the attenuation of the filter is constant. In addition to this effect, it is possible that the inductance be operated at such values of load current so as to saturate the iron core and thus decrease the effective inductance of the choke. This decrease in inductance reduces the filter attenuation and thus allows a larger ripple voltage to appear in the output. Moreover, the magnetizing current of the choke coil increases very rapidly as the iron of the core becomes saturated, thus producing an AC voltage which appears in the output.

The curves of Figure 19 were obtained in order to determine the efficiency of filtering a single section using, (1)- an 8 mfd. input condenser, a 20 henry choke and a 16 mfd. output condenser, and, (2)- a 16 mfd. input condenser, a 20 henry choke and an 8 mfd. output condenser. It will be noted that the output voltage is slightly higher for

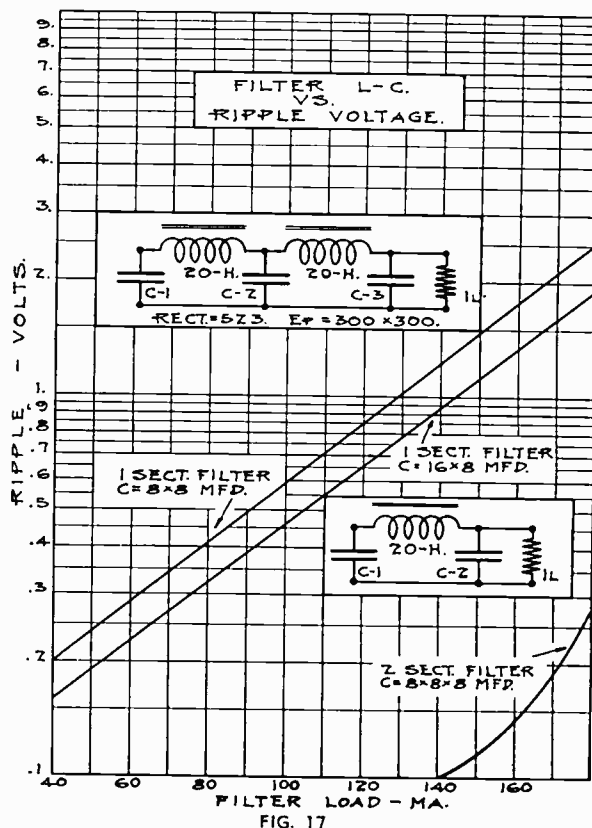
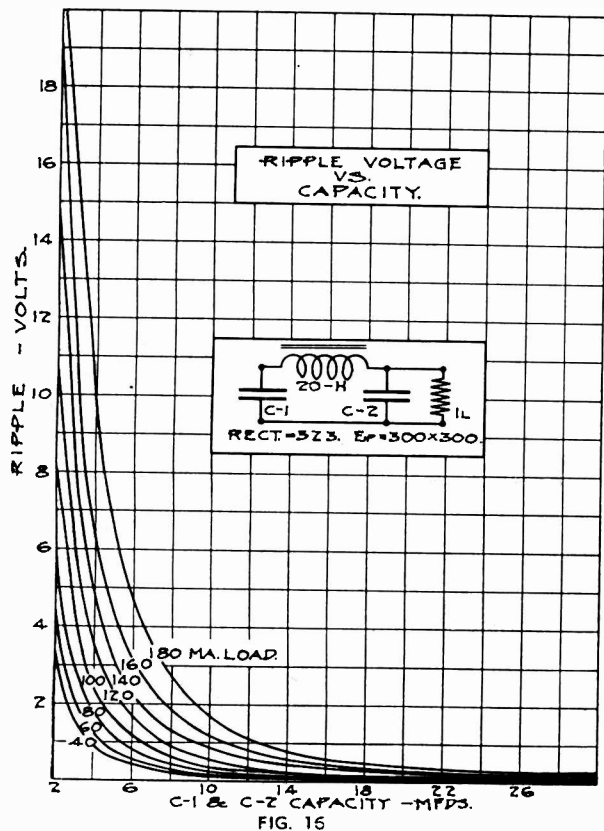

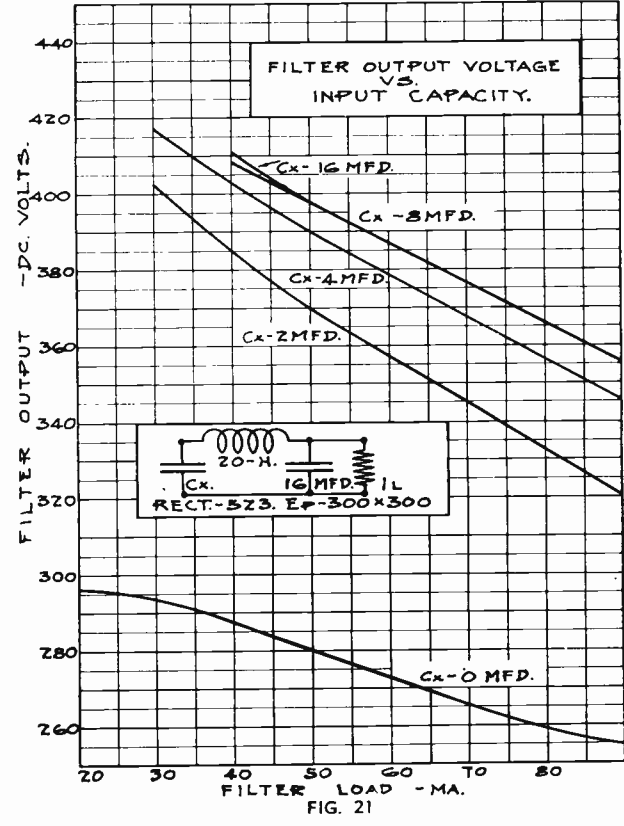
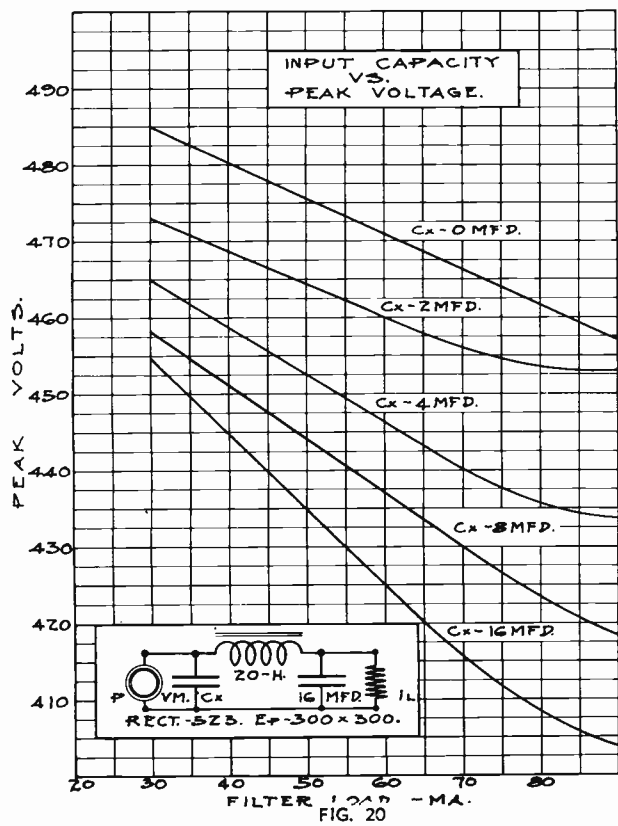
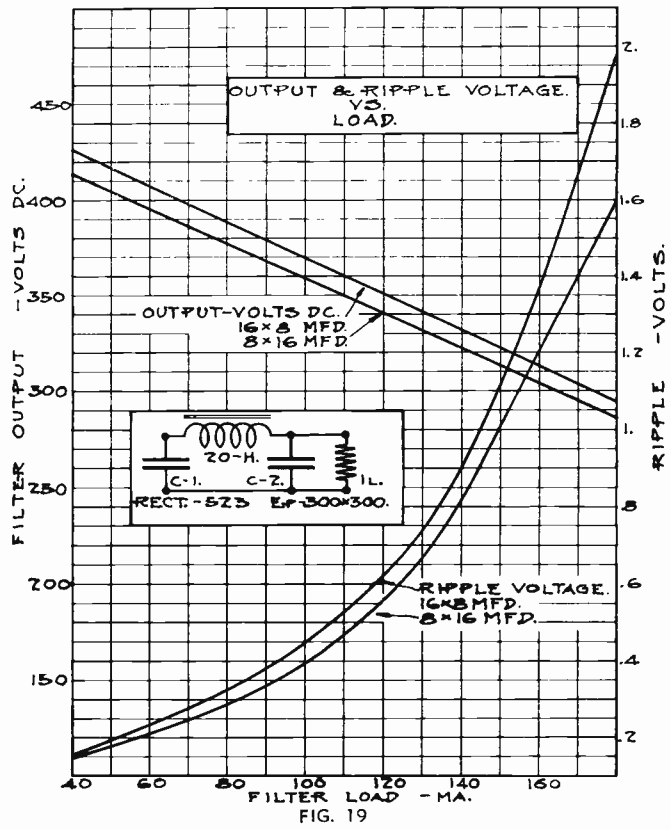
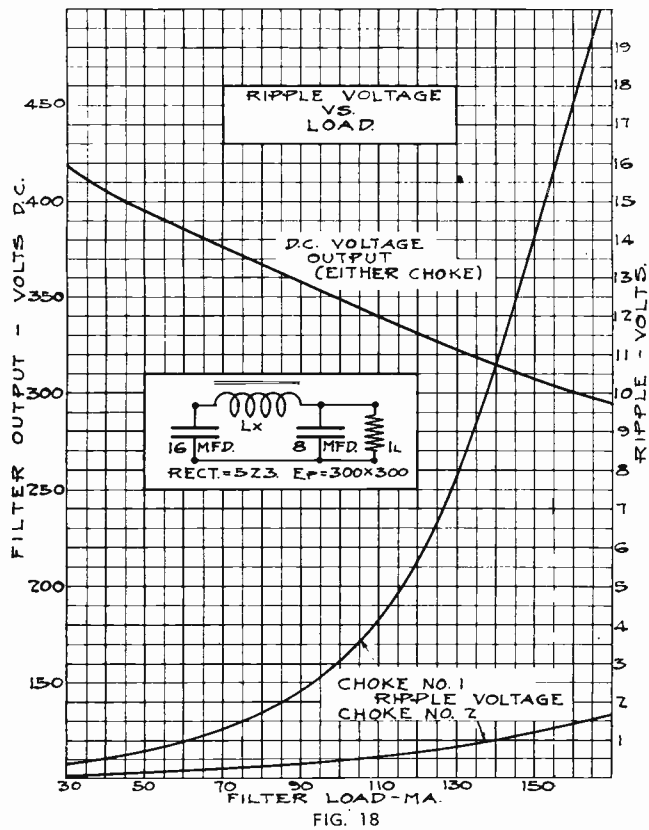





that within the limits of measurement, that the effect of power factor in filter condensers is negligible for power factors up to and including 30%, and as the average power factor of a dry electrolytic condenser is approximately 5 to 10%, no attention need to be paid to condenser power factor as far as filtering efficiency is concerned. A high power factor, however, means that the power lost in the condenser is high and for condensers having limited radiation facilities, the losses produced by the added series resistance as indicated by a higher power factor, may be sufficient to raise the temperature of the condenser sufficiently high to effect its characteristics. The effect of temperature is to increase the leakage current of the condenser. A high power factor condenser, therefore, introduces a condition which is cumulative in its effect, the higher power factor causing a greater temperature and the increased temperature causing still higher losses.

The curves of Figures 24 and 25 were included to show the effect of two different transformers, one being a transformer liberally designed and properly engineered and the other being a transformer of much cheaper construction. These curves are of interest inasmuch as they show the effect of transformer regulation on the characteristics of the filter. The curves are self-explanatory. It is interesting to note the effect of the input capacity on the DC filter output voltage of the two transformers used. The output voltage for transformer number 1 increases from about 230 volts to 315 volts at an input capacity

of 7 mfd. and thereafter remains constant. For the transformer number 2 the voltage increases from 170 volts at 1 mfd. to 210 volts at 4 mfd. and thereafter remains constant. The difference in the output voltages for the two transformers, although each transformer is rated at 300 volts, either side of the center tap, is due to the poorer regulation of the cheaper transformer. After the capacity reaches a value at which the voltage becomes constant, further increases in capacity do not effect the output voltage as the voltage drop across the condenser becomes smaller, thus counter-acting the greater tube drops caused by the increased peak tube currents, and the voltage drop of the transformer.

These curves illustrate graphically the various conditions that exist in typical rectifier circuits. Using this information it is possible to determine the action of a rectifier under various conditions of load and filter circuits. It should be noted that the action of the rectifier tube depends on the type of filter input circuit, and not only is the DC output voltage determined by the filter used but the ripple output voltage is also greatly affected by the filter circuit. The filter circuit used determines both the AC ripple input to the filter and the ripple attenuation in the filter. The peak plate current is also determined by the type filter circuit used, and for tubes having a low impedance drop, condenser input filters should not be used as the peak plate currents rise rapidly with a decrease in the tube impedance. Large tube cur-

rent not only decreases the life of the tube but also increases the heating of the plate supply transformer necessitating the use of a larger transformer to deliver a given DC output. There is very little to be gained by the use of excessively large input filter condensers as the DC voltage does not increase materially after capacities greater than 8 to 10 mfd. have been reached. The use of larger condensers at the filter output does help to reduce the ripple output voltage and has no effect on the tube currents.

In the use of electrolytic condensers in filter circuits, one must consider the effect of power factor and leakage current. As discussed above, power factor has no appreciable effect on the filtering efficiency of the condenser but has considerable effect on the heat developed in the condenser. The effect of leakage current is similar to the effect of power factor in the condenser. A high leakage current decreases the efficiency of the rectifier and increases the load on the tube and transformer, just as a shunt resistance would produce the same result. As in the case of a condenser with high power factor, a high leakage current causes a rise in the temperature of the condenser which in turn increases the leakage current and therefore, the temperature. In the application of electrolytic condensers, care must be taken to choose condensers having low leakage current and to locate them in well ventilated places removed from sources of high temperature.

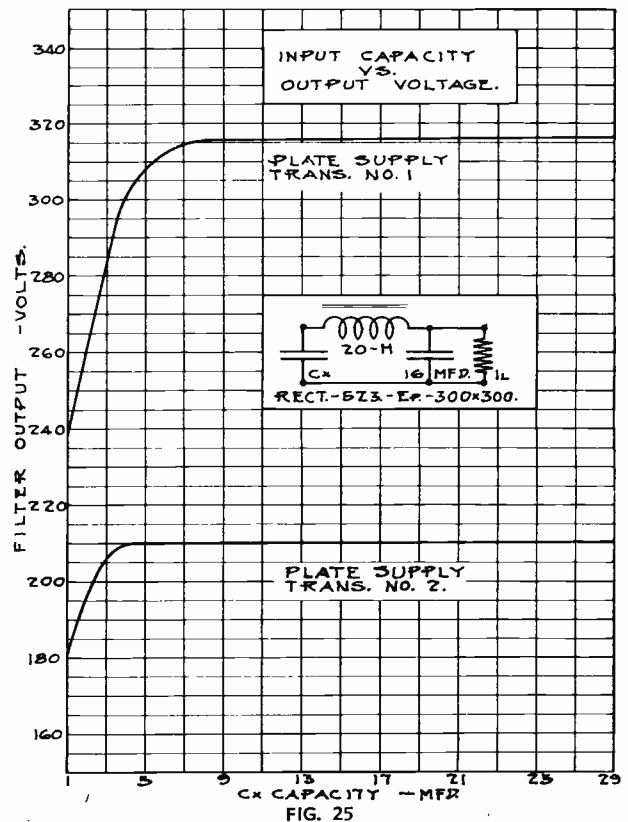
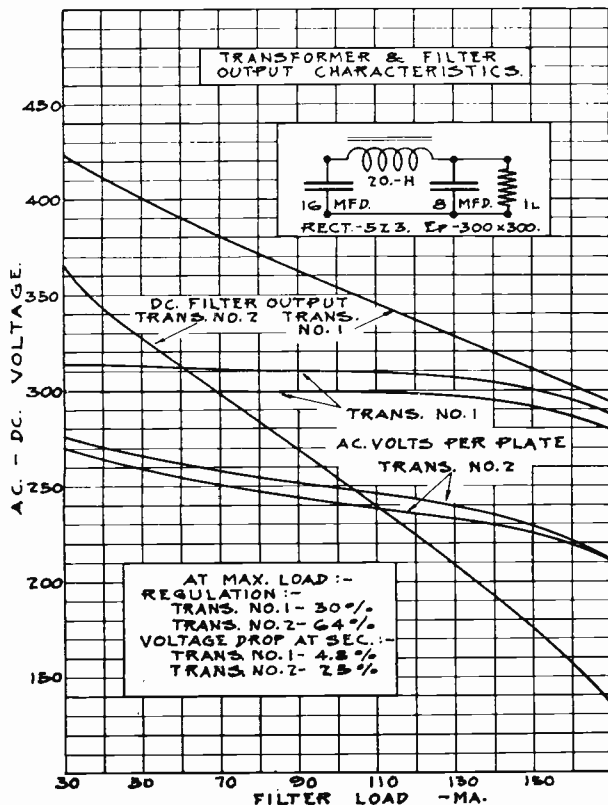



AEROVOX offers you the most extensive and accurate listings of motors and their capacitor replacements.

AEROVOX provides exact-duplicate replacements that positively match initial equipment — electrically, mechanically, visually.

Also several general types that serve for a number of different types of motors.

Widest choice of containers, terminals and mountings to fit any style motor.

Electrolytic capacitors for intermittent or starting duty. Extremely compact. Fully dependable. Inexpensive.

Oil-filled capacitors for continuous duty applications, and especially for power-factor correction functions.

# MILLIONS now in daily use!

In electric refrigerators, oil burners, home workshop equipment and countless other applications, you'll find capacitor-type motors at work. • And in the major portion of installations, you'll come across AEROVOX CAPACITORS. Why? • Simply because AEROVOX pioneered the dry electrolytic motor-starting capacitors. And AEROVOX has stayed well in the lead. • Which means that you too can best depend on AEROVOX for new or replacement capacitors.



## Get Your Copy . . . .

New industrial capacitor catalog, listing popular types of capacitor-type motors and their replacement needs, is yours for the asking. Please write on your business stationery. Meanwhile, remember that the live-wire local jobber stocks AEROVOX motor-starting capacitor replacements.



# AEROVOX CORPORATION

70 WASHINGTON STREET, BROOKLYN, N. Y.



Sales Offices in All Principal Cities