

D-i-Y RADIO



January-February 1993

Volume 3: No 1.

An Introduction to Amateur Radio - For Beginners of all Ages

**D-i-Y Radio
Review:
AM Medium/
short-Wave
Radio Kit
from Tandy**

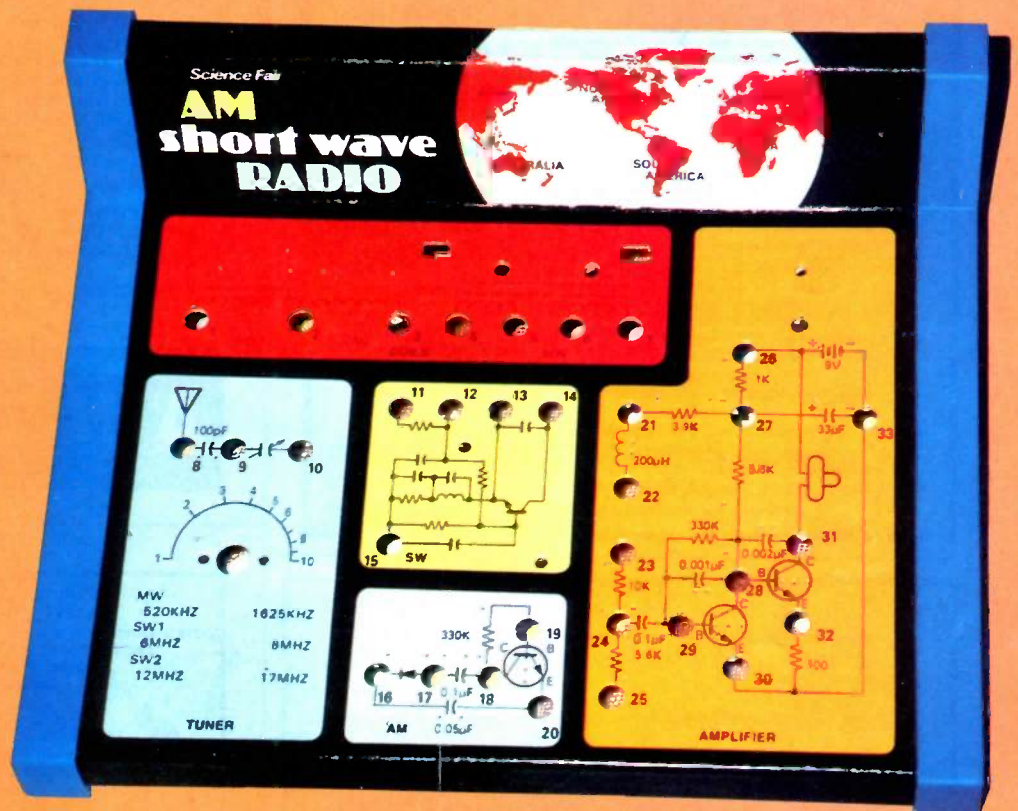

**From the
D-i-Y Radio Stable:**

**The COLT
Receiver**

**The start of
our major new
construction series**

QRP KITS AT QRP PRICES!

Guaranteed complete to the last nut!

COMPACT 80m CW QRP Tx/Rx

DTR3 KIT — £87.50 Ready Built — £140.00

Postage & packaging £3

- ★ Stable VFO ★ Sidetone ★ Audio Filter
- ★ Requires 12/14 VDC ★ Very detailed Instructions ★ Black steel case
- ★ Printed panel

160m and 40m models available at same prices

COMPANION ANTENNA TUNING UNITS

TU1 Kit — £41.25 Ready Built — £57.50

TU2 Kit — £51.00 Ready Built — £72.00

Postage and packaging £3

- ★ Large dia coil ★ High grade capacitor ★ Built in balun ★ Circuits to match your antenna ★ Up to 30 Watts of CW ★ TU2 has sensitive QRP/SWR meter

QRP SWR METER

- ★ Specially designed for QRP ★ HF 1-30MHz

★ Can be set down to 1/2 watt for FSD

- ★ Ideal for milliwatting ★ Low insertion loss 0.2dB

TUA1 Kit — complete case & meter £18.00 + £1 p&p.

CARLTON

80-40-20m Dc Rx

- ★ Receives USB, LSB and CW ★ Very sensitive and selective ★ Simple modular construction
- ★ 12-14 volt battery operated ★ Printed fascia

Kit complete with case — £69.50 plus £3 p&p.

PSU 15 REGULATED POWER SUPPLY

- ★ Ready built ★ Mains input ★ 13.8V @ 1.5A output
- ★ Ideal for DTR3 & 'Carlton' ★ Fully protected

Supplied ready built — £52 plus £4 p&p.

Send SAE for brochure or call Alan G4DVG on 0602 382509

LAKE ELECTRONICS

7 Middleton Close, Nuthall, Nottingham NG16 1BX
(callers by appointment only)



Complete your tools with Antex Soldering Irons

The art of accurate soldering is to maintain the bit temperature at the optimum level.

Antex fixed setting, thermally balanced, high efficiency irons maintain constant tip temperature and offer a wide range of soldering bits to suit your particular application.

For the more sophisticated applications, control at lower temperatures is essential. In these cases an adjustable temperature soldering iron is required. Also available are soldering stations with the option of digital temperature read out.

Antex products are designed for precision soldering to meet the demands of precision electronics.

Ask for Antex by name at leading Electronics distributors.

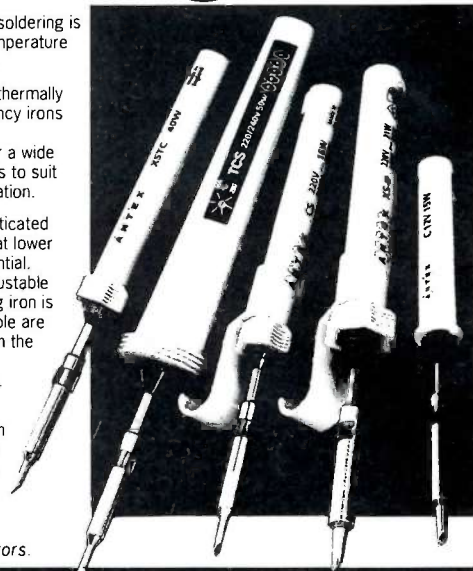

ANTEX

Antex Electronics
2 Westbridge Ind. Est.,
Tavistock, Devon PL19 8DE
Telephone: (0822) 613565
Fax: (0822) 617598

Practical Antennas for Novices

THIS GUIDE, written specially for UK Novices by John Heys, G3BDQ, tells you how to build good, simple antennas (aerials) for each of the Novice bands from 1.8MHz (short-wave) to 434MHz (UHF), plus construction projects to ensure they are working correctly. A chapter is devoted to safe common sense ways of setting up antennas for transmitting and receiving. This book will suit not only Novices, but also any beginner looking for easy-to-build antenna systems that really work. 60 pages.

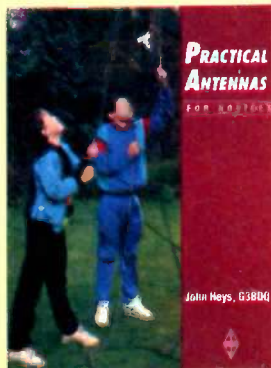

Available from the Radio Society of Great Britain.

RSGB Members price: **£4.83** (inc. post & packing)

RSGB Non-members price: **£5.50** (inc. post & packing)

Send to:



Radio Society of Great Britain
Lambda House, Cranborne Road,
Potters Bar, Herts. EN6 3JE

KANGA's QRP KITS

How about building a kit? A RECEIVER, TRANSMITTER or perhaps a piece of TEST EQUIPMENT. Many of our kits are from the G-QRP club too.

Many are ideal for the beginner to construction.

Send an SAE for our FREE catalogue to:

KANGA PRODUCTS

3, Limes Road Folkestone CT19 4AU
Tel/Fax 0303 276171



RSGB Amateur Radio Call Book and Information Directory

A massive 433 pages

RSGB Members price: **£9.00** (inc. post & packing)

RSGB Non-members price: **£11.50** (inc. post & packing)

Send to:



Radio Society of Great Britain
Lambda House, Cranborne Road,
Potters Bar, Herts. EN6 3JE



● TWO SMALL boats called 'May Day' when they were in trouble in the Pacific Ocean and Bob McCandless, N3KW, a radio amateur employed as a radio operator on the SS Cape Bover was passed the emergency call from the US Coast Guard. The SS Cape Bover was returning to the United States after a 13-month tour of duty in the Persian Gulf. Thanks to prompt action the sailors were rescued - all via the amateur radio network again!

● THE SALISBURY Radio and Electronics Society (SRES) has placed a plaque on Three Mile Hill near Salisbury which was the site of some of Marconi's earliest radio experiments 95 years ago. At the ceremony were representatives of the GEC-Marconi company, the RSGB and the Royal Signals Regiment.

● WHEN HURRICANE Iniki struck the Hawaiian island of Kauai in September, 165MPH winds made 8,000 people homeless. Amateur radio provided the only link with neighbouring islands.

Yugoslavia Relief

IN MARCH 1991, some British radio amateurs joined a team of volunteers providing relief work in Romania. They provided communications between hospitals, orphanages and stores, and from the town of Turnu Severin to the UK.

The group, now called Radio Amateurs Relief Expeditions, went to Yugoslavia immediately after Christmas to help with the relief convoys.

● THE SOUTHEND and District Radio Society has loaned a receiver to the Essex Bosnian Refugee Group to enable them to listen to news from home.

Mark's Window on the World



NOVICE LICENSEE
Mark Mathews

(12), who has been blind from birth, has been able to make friends all over the world without moving from his chair, thanks to amateur radio.

Mark received his Novice training at the Highfields Disabled Amateur Radio Club in South Wales where able bodied members help disabled members to learn about radio and electronics.

Although the Novice course has some practical work, Mark was still able to join in. He built a receiver which didn't involve soldering - and it worked! He assisted one of the helpers in building test sets and an audio amplifier, and putting plugs together. Being unable to read the instructions, he listened, learned and worked very hard.

Then came the exam last

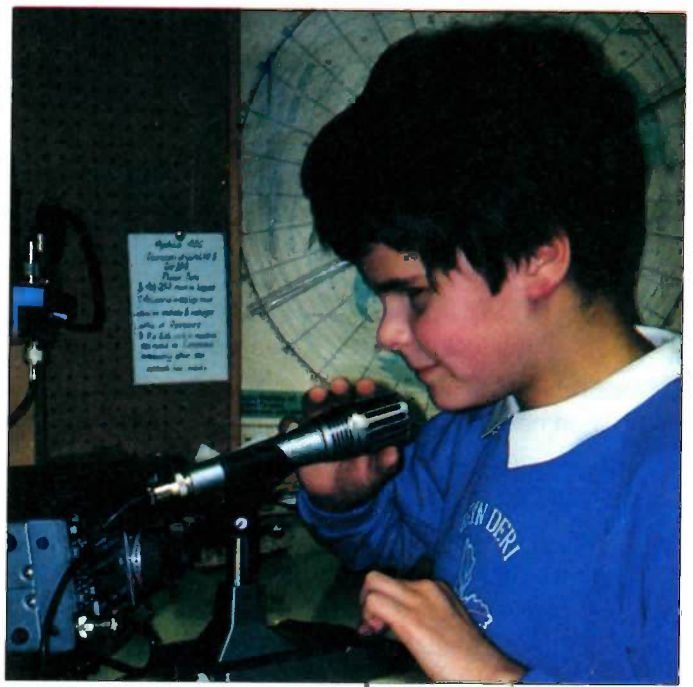

Twelve year old Mark in the radio shack of the Highfields Disabled Amateur Radio Club. Blind from birth, Mark (2W1BDD) has the world at his fingertips.

September. The questions were read to Mark along with the choice of answers. Diagrams had to be described so that he could answer. He was rewarded with an exam pass and proudly holds the callsign 2W1BDD.

Mark can now use the radio club's equipment and he

will soon have his own home station provided by the Radio Amateur Invalid and Blind Club.

Congratulations, Mark, from all at the RSGB. We hope that your example will help other disabled people to 'travel' the world using amateur radio.

£4,500 Raised for Albanian Handicapped



Some more fund raising: RSGB staff came to work for a day dressed as teddy bears and raised nearly £200 for Children in Need. Your Editor made this Pudsey cake for the teddy bears picnic lunch.

THE RSGB appeal for money to help handicapped people in Albania has raised £4,500. The appeal is in aid of MENCAP whose President, the Lord Rix, is a radio amateur (G2DQU) and a Vice-President of the RSGB.

Sponsored activities included slimming, giving up smoking, swimming and radio contacts. Mike Costello,

G3YPP, ran in the London Marathon for the appeal and Amanda Baird, G0RZK, made a parachute jump!

Several companies donated prizes for the best fund-raisers. The *D-i-Y Radio* subscriber raising the most was David Dennison who did a sponsored run. He wins a radio from Nevada Communications.

D-i-Y CONSTRUCTION FEATURE

The D-i-Y Radio Colt

A step-by-step guide to building your first receiver by Rev. George Dobbs, G3RJV

Part 1: The Audio Amplifier Module



IT IS NEARLY FORTY YEARS since I built my first radio set. It was a simple crystal set but all these years later, there's always a thrill when hearing the first signals from a radio I've built myself. Although I build other electronic circuits, making something that can pluck radio signals out of the air and turn them into sounds is the real essence of our hobby.

Stage by stage we are going to follow the design and building of a simple radio capable of good reception of radio amateur signals on the 80 metre band. If you can solder and have some basic hand-tools then this series will enable you to make a useful amateur radio receiver. A multimeter and another radio receiver are all that are needed for testing. Perhaps if you are a member of a radio club or know a radio amateur they could help in the final setting up of the receiver.

The radio is built in four **modules** (stages); **Fig 1**. Each of these is built on a printed circuit board and can be tested in its own right. Also, each is available in kit form. The case will need some holes drilled and careful mounting of the boards to fit the modules into the case.

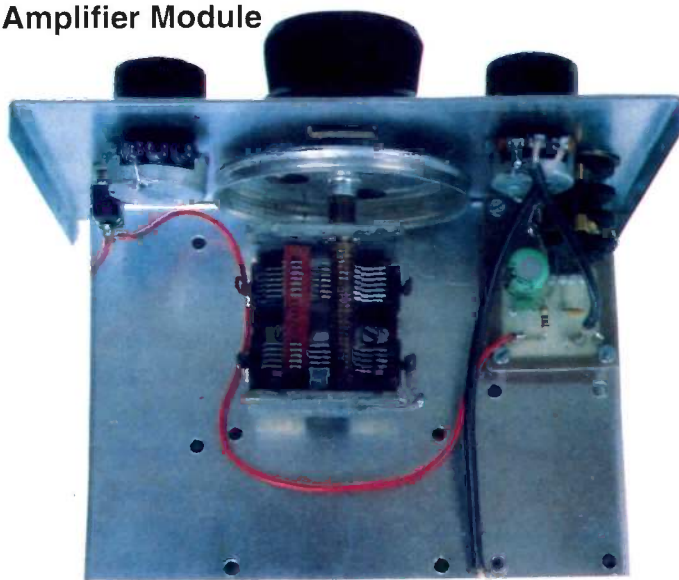

So get out the tools, practice making good solder joints and prepare to have fun!

The usual way to build a radio receiver in easy stages is by beginning at the output and working towards the input. This means you can hear interesting stations right at the start and test that everything is working. Every receiver needs some audio (sound) amplification - this makes the signals loud enough for you to hear. The

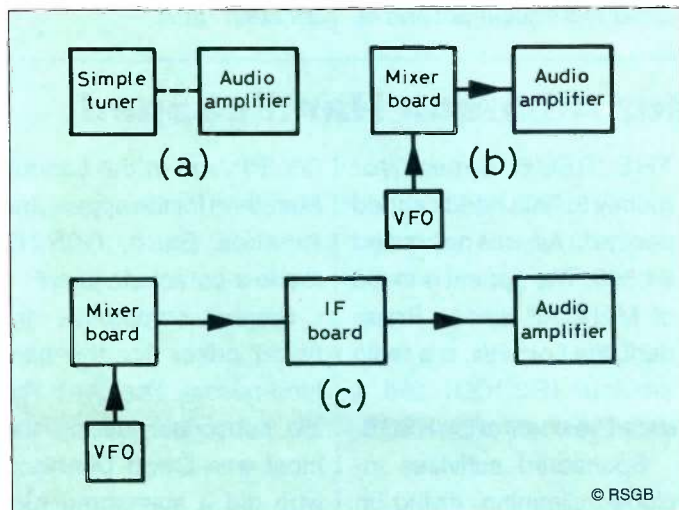

Fig 1: Build your Colt and watch it grow. A simple crystal set (a) becomes a direct conversion receiver (b) and finally an 80 metre amateur band superhet (c). For details of the crystal set construction see page 6.

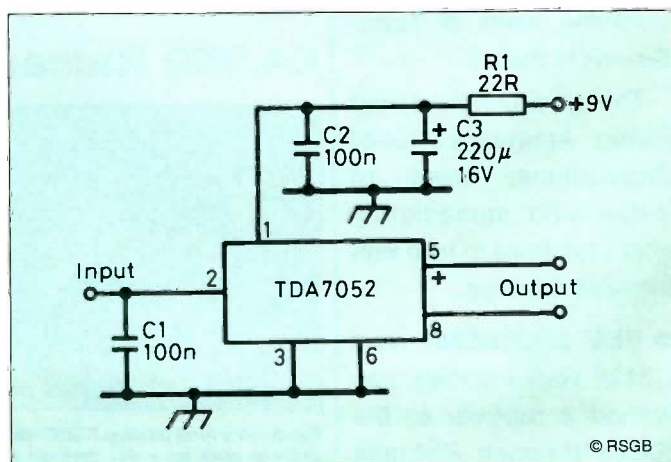

Fig 2: The Philips TDA7052 integrated circuit (IC) used in the audio amplifier needs very few extra components. It has a signal voltage gain of 100 times and the output is suitable for a loudspeaker or headphones.

circuit for the audio amplifier which we'll use in the *D-I-Y Radio Colt* is shown in **Fig 2**.

It's a very simple circuit with hardly any parts and uses an audio amplifier integrated circuit (IC) or chip - the TDA7052. The output leads must be taken to an insulated socket which will not connect either side to the case. A plastic 6.3mm (0.25in) mono jack socket (eg Maplin FJ00A) is used here.

NEXT TIME IN D-I-Y RADIO

FULL DETAILS of how to build a smart metal case for the 'Colt' radio. This will be your next step along the road to a complete communications receiver. Don't miss it!

THE RIGHT CONNECTIONS

THE ONLY EXTRA PARTS besides the IC are R1, C2 and C3 which prevent any interference on the battery line (these are known as **decoupling** components). The amplifier is built on a small printed circuit board which is available from Kanga Products. Building it is simple, just push the components into the correct holes and make good solder joints on the foil side. Some parts, such as the TDA7052 *must* be put into the board the right way round. Pin 1 of this IC (see **Fig 3**) goes into the hole

nearest C3. The completed board also requires a volume control and a 9 volt battery. Of course it is important to connect the battery the right way round. Either a PP3 or PP9 type is suitable. The volume control is a 10k Ω logarithmic type, and connections to this are best made using screened lead (see **Fig 3**). The amplifier lead from the volume control has the inner wire connected to 'in' (input) and the screen connected to 'gnd' (earth).

The output from the amplifier will drive either a pair of headphones, such as those for a 'Walkman' (see *Ham Facts* page 12 for a suitable adaptor) or a small 8 Ω loudspeaker (LS).

COMPLETION AND TESTING

NOW THE AMPLIFIER can be tested. Check that the soldering is good, and all the components are in the right place before connecting the battery. When the set is switched on a slight hissing sound should be heard in the headphones or loudspeaker. Touching the input of the volume control will produce a loud buzz, a sure sign that the circuit is amplifying. Turning the volume control clockwise should increase the volume, if not reverse the two outside leads on RV1.

AUDIO AMPLIFIER BOARD COMPONENT LIST

INTEGRATED CIRCUIT

IC1 TDA7052 (Maplin code UK79L)

RESISTORS

R1 22 Ω

RV1 (Volume control) 10k log. (such as Maplin FW22Y)

CAPACITORS

C1 0.1 μ F Ceramic

C2 0.1 μ F Ceramic

C3 220 μ F Electrolytic 16V.

ADDITIONAL ITEMS

Printed circuit board (see below)

SUPPLIERS:

Maplin Electronics, PO Box 3, Rayleigh, Essex, SS6 2BR.

Tel: 0702 554161

A FULL KIT OF PARTS WITH PCB IS AVAILABLE FROM:

Kanga Products 3 Limes Road, Folkestone, Kent, CT19 4AU.

Tel: 0303 276171. Price £9.99 including p&p

The PCB only is also available. Price £3.50 including p&p

Delivery 4/5 weeks from receipt of order.

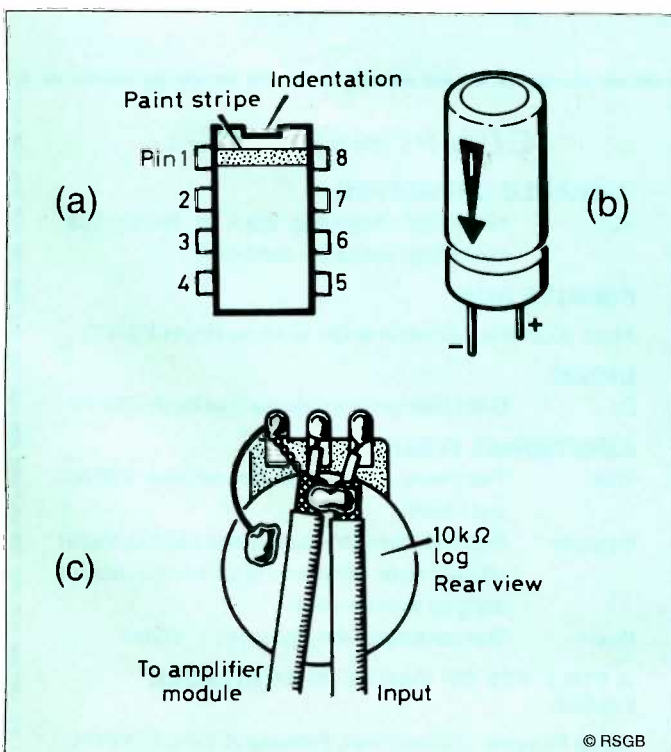

Fig 3: It is important to check the component connections carefully. The diagram shows (a) top view of the IC, (b) electrolytic capacitor and (c) volume control (RV1) connected across the input of the amplifier.

D-i-Y CONSTRUCTION FEATURE

Crystal Radio Receiver



IF YOU'VE BUILT THE FIRST MODULE (the amplifier) of the *D-i-Y Radio* Colt you might like to try a neat way of testing it before building the next stage. A crystal set tuner can convert most amplifiers into a simple radio, and a suitable circuit is shown in **Fig 1**. It has a coil wound on a ferrite rod (see *Ham Facts* page 12), which is mounted on a piece of card as shown in the photo. About

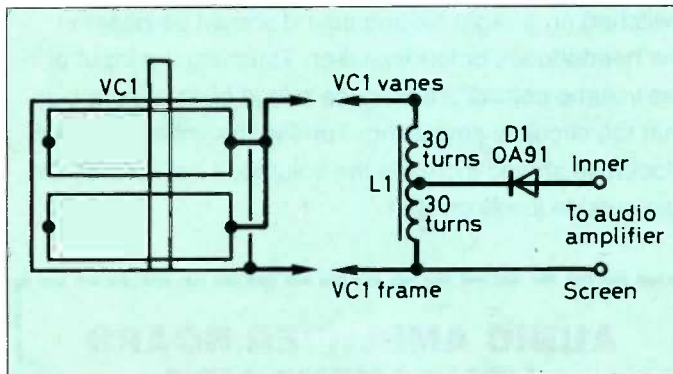
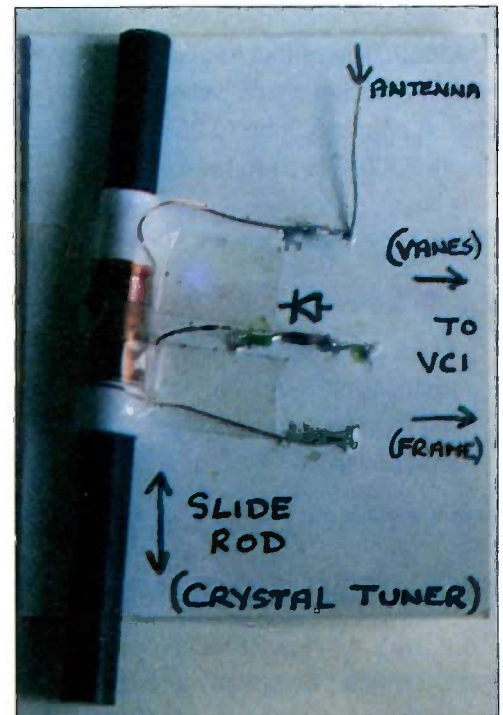

Fig 1: Both sets of moving vanes are joined as shown. L1 is wound on a ferrite rod with 32SWG wire and centre-tapped. A single winding (no tap) can be used, joining D1 to the top of the winding.

60 turns of wire with a tapping point in the middle usually works well. The

particular tuning capacitor in the parts list will also be used in later stages of the Colt receiver, but the coil is only needed for the crystal set. You should now be able to tune into several local stations on the medium wave band using a simple wire antenna.

A crystal earpiece can be used instead of the amplifier if you don't want to use a loudspeaker.



AUDIO AMPLIFIER KIT OFFER

Use one of your subscribers' special 50p offer vouchers to buy a complete kit for the *D-i-Y Radio* Audio Amplifier. Send £9.99 plus one voucher (inc post and packing) or £10.49 if you are not a *D-i-Y Radio* subscriber, to Kanga Products, 3 Limes Road, Folkstone, Kent CT19 4AU.

**OFFER CLOSES
28 FEB 1993**

COMPONENT LIST

VARIABLE CAPACITOR

VC1 125+125pF Twin-gang (such as 'Novice type' from Kanga products - see below)

FERRITE ROD

About 100mm to 140mm in length (such as Maplin YG22Y)

DIODE

D1 OA91 Germanium diode (such as Maplin QH72P)

ADDITIONAL ITEMS

Wire Two metres of insulated wire between 23SWG and 32SWG

Earpiece High Impedance crystal earpiece (such as Maplin LB25C) Note: this is only required if you are not using an audio amplifier.

Board Thin cardboard, size about 150 x 100mm

A FULL KIT OF PARTS IS AVAILABLE FROM:

Kanga Products, 3 Limes Road, Folkstone, Kent, CT19 4AU.

Tel: 0303 276171 Price £6.95 including p&p



D-i-Y NEWS FEATURE

A White Antarctic Christmas



LAST TIME we told you about the Pentland South Pole Expedition in which Sir Rannulph Fiennes and Dr Mike Stroud are attempting to walk 2,200 miles across the Antarctic. This is to achieve the first totally unsupported crossing of the South Pole by either dogs or other transport, and to raise two million pounds for the Multiple Sclerosis Society.

110MPH WINDS

THEY ARE now a quarter of the way through their journey and have walked over 400 miles through very rough terrain. They have walked every day but one, when winds were gusting at 110 miles per hour. Their sledges weigh over 400lbs

each, so you realise the extent of their challenge. At one point Ran had to rescue Mike who had slipped onto a small snow platform in a huge crevasse. Fortunately the pair of them had practised how to get each other out if this happened. Neither of them was injured during this incident but Mike's sledge was badly damaged and the harness had to be repaired.

Ran radioed from over 5,000ft on their ascent to the Antarctic Plateau and their position is now 84° South, 40° West. He said, "We are walking for ten hours every day hauling sled loads which began at 460lb and still weigh 370lb each. The ground is like a giant ploughed field, with craggy ice dunes and concrete-hard ridges feet

high stretching in endless lanes across our path. For several days driving snow has caused almost complete white-out and hard hauling conditions".

EXTREME COLD

RAN SAID that Mike had treated an abscess with antibiotics, but his own lips were cracked and bleeding from cold sores caused by ultra violet light from the hole in the ozone layer.

They are at present having to eat far more than planned each day, to enable them to cope with the enormous stress of hauling the sleds, the altitude and extreme cold. Despite more food they have each lost more than 22kg in weight so far.

RSGB member Morag Howell, VP8/GB4MSS, is now fully operational from her base (a small unheated tent) below the Antarctic Ellsworth Mountains with temperatures dropping to minus 15C. Morag is radio operator for the expedition and in daily contact with Ran and Mike. She then relays information back via a satellite link to her husband Lawrence, GM4DMA, at home in Aberdeen.



A practise rescue up the Trade Tower in London prior to setting off.

SATELLITE CONTACT

BEFORE LEAVING, Morag obtained a portable Inmarsat terminal and is using this to link up with the Antarctic satellite for two-three hours per day.

You may also hear Morag from the South Pole if you listen on the HF amateur bands. Remember that they would be glad of donations to their Multiple Sclerosis Appeal, which you can send via D-i-Y Radio.

The message from everyone involved is very clear "We can reach a goal that has never been achieved before - not even with vehicles or dogs - and which everyone thought impossible".



Our D-i-Y Radio poster, Vol 1: No 2, sets the scene.

Amateur Radio and Computers

Satellite tracking: This computer program has details of the 'orbits' of several amateur radio satellites and it can display which part of the world can 'see' each satellite. It can also be connected to motors which point an amateur station's aerial towards the satellite, following the satellite's path round the earth.

Logging: Radio amateurs have to keep a record of their transmissions (the Log). It is now possible to keep the log on a computer disk and this makes it easy to look up a callsign to see whether a contact has previously been made with that station.

ABOVE YOU CAN SEE some of the many ways computers can help radio amateurs enjoy their hobby. There are many more, such as programs which help in designing circuits, printed circuit boards (PCBs) or aerials. A computer could be used to remotely control a transceiver or it can act like a

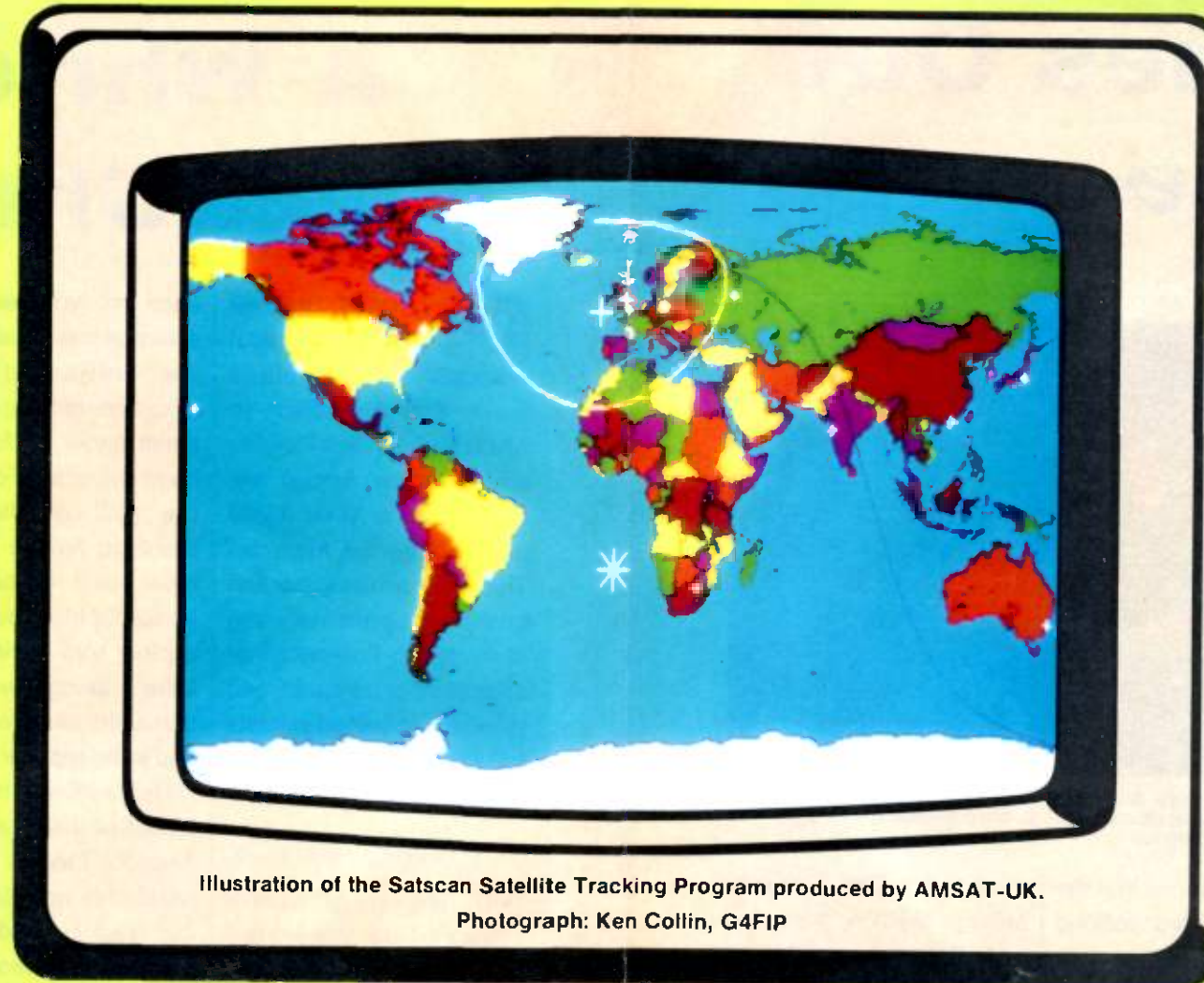
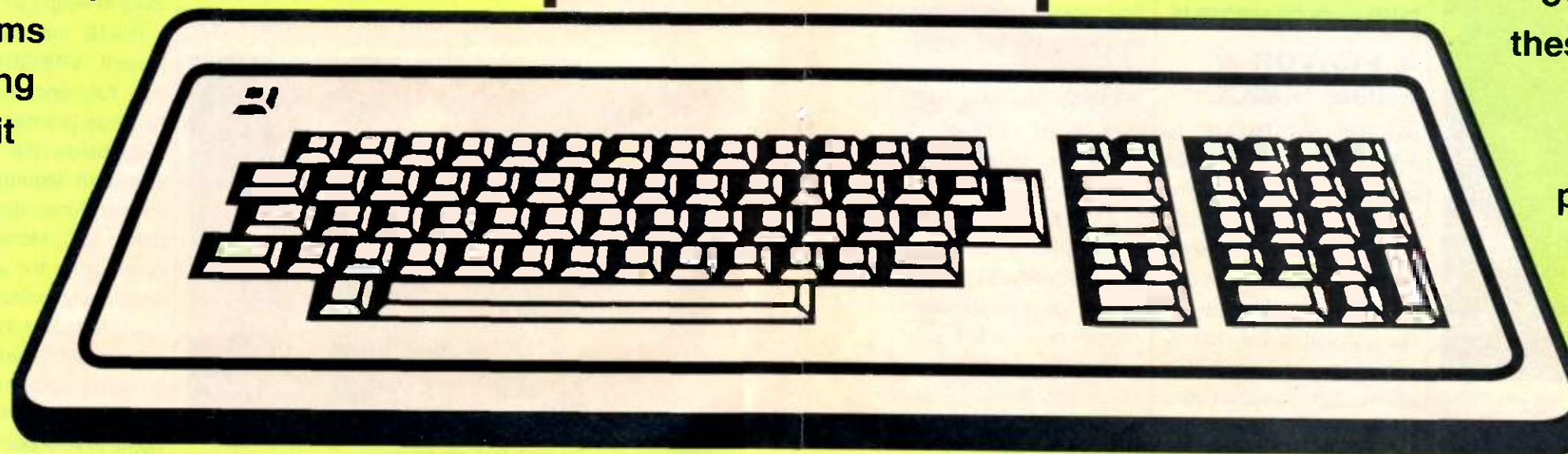

Illustration of the Satscan Satellite Tracking Program produced by AMSAT-UK.
Photograph: Ken Collin, G4FIP

Packet Radio: This type of 'data' communication enables radio amateurs to link to each other's computers by using their radios. Messages can be left on 'bulletin boards' which also carry news and information. A system known as 'DX Cluster' allows news of interesting stations to be passed around quickly.

Morse code: Computer programs, such as those in *D-i-Y Radio*, Vol 2, Nos 3-4, can be used to make Morse for practising the code. More complicated programs can even listen to Morse and decode it, printing out the words on the screen.

teleprinter, fax terminal or even a television for sending and receiving these signals over a radio link. Many of these programs are written for the 'IBM' PC-type computers, but it is possible to buy amateur radio programs for the ZX Spectrum, Commodore 64, BBC-B, Atari ST and others.



D-i-Y NEWS FEATURE

School Reaches Out to Space



LAST JULY, at the University of Surrey, science teacher Frank Bell explained to a satellite conference organised by AMSAT-UK how his school used amateur radio to make space science fun.

Frank's class at The Royal Grammar School in Guildford had sent typed messages via a satellite's computer to a girl's school in Australia. Messages were also exchanged with a Greenpeace base in Antarctica and with South Africa and Pakistan.

Another project followed the progress of the Skitrek North Pole Expedition by lis-

tening to a satellite computer's 'voice' - the Digitalker. They were also the first to contact British Astronaut Helen Sharman on the Mir space station (see *D-i-Y Radio*, Vol 1: No 1).

A great deal of fun and knowledge was gained from building a receiver to listen to the 'telemetry' from UoSAT-2. Telemetry is information about the satellite which helps the control station (at the University of Surrey) keep track of how well it is working. It can only be 'read' by a computer so the students had to write their own program to learn more about the satellite.

Frank, callsign G7CND,



With Helen in the Royal Grammar School's radio room are Leslie Starkie, 2E1AEG, and Chris Jozefowicz, G7HEE. In the background is Head of Science Frank Bell, G7CND.

told the conference that the next projects were studying photographs taken from space, and becoming involved with the American Space Shuttle Amateur Radio Experiment (SAREX) which will allow his students to talk to shuttle astronauts.

A VISITOR FROM SPACE

HELEN SHARMAN is following up her radio contacts with schools by a round-Britain tour, and she visited The Royal Grammar School in October. Pupils listened enthusiastically to her account of her journey into space, and then in the afternoon pupils were invited to come in from eight neighbouring schools to

meet Helen. Dick Biddulph, callsign G8DPS, accepted an invitation on behalf of the *D-i-Y Radio* team to go along and report the visit.

On 22 October Helen visited the Harrogate Ladies College, whose school amateur radio club was involved in setting up the amateur radio links with Helen on the Mir space station in 1991.

In March 1992 the College became the first UK school to be selected to have a SAREX contact with US Space Shuttle Atlantis and were successful in contacting the crew as the shuttle passed over the UK.

The College amateur radio club started in 1978 and since then 35 girls have obtained licences.



Helen Sharman meets Harrogate Ladies College pupils: (l to r) Anna, G7IRR (now at Oxford); Felicity, G7NSP; Jenny, G7KZO; Rebecca, G7NSQ, and Katy who was a stranger to amateur radio until she won the school competition to ask Helen a question over the air. She is now G7NST. Looking on is Richard Horton, G3XWH, Head of Physics and IT.

D-i-Y EQUIPMENT REVIEW

Tandy AM Short-Wave Radio Kit

A medium-wave and short-wave radio to build without soldering.



FOR LESS THAN £13, Tandy offer a beginner's construction kit, made by Science Fair, which can be connected either as medium-wave crystal set or a short-wave *super-regenerative* receiver. The kit comes complete with all parts including an aerial wire, but a 9V battery (PP3) must be bought separately. There is also a helpful step-by-step instruction book.

NO SOLDERING

THE FIRST JOB IS TO INSERT 33 springs into the cardboard panel. All of the connections are made by putting component leads or wires into these springs.

The components are pushed through holes in the panel which is marked with the circuit diagram, and then pushed into the spring connectors. Advice is given on how to fit the transistors, diode, electrolytic capacitor and battery, which must be connected the correct way round.

IT WORKS!

BUILDING THE KIT TOOK 9-year-old David two hours with a little help from his Dad. It was very important to check all connections before switching on, and to help

with this the book includes a drawing of the underneath of the finished radio.

The most exciting part of any project is switching it on, especially if it works. This kit worked first time and gave good reception of a local Radio 1 and Radio 5 transmitter on the medium-wave. An earpiece is provided but the sound was enough to drive a loudspeaker (not supplied).

To make the radio receive short-wave signals, it must be wired up differently but this takes only a minute or two. There are two bands: 6 - 9MHz and 12 - 17MHz; stations from all over the world can be heard on these frequencies.

The short-wave receiver was rather disappointing. Some stations were heard fading in and out in a fascinating way but it wasn't easy to listen to a particular station for any length of time.

CONCLUSION

IF YOU JUST WANT A short-wave receiver, it's best to buy a ready built one. But if you want a fun way to learn about radio circuits, this inexpensive and easy-to-build kit is just the thing.



First lay out all your components.



Almost finished – just the battery to fit.



Great – it really works!

D-i-Y HAM FACTS

Meet Henry and Ferrite Rod



AS YOU HAVE PROBABLY found out if you've looked inside one, all radios have coils of one sort or another. Another name for a coil is an **Inductor** and the value of inductance is the **Henry**. For use in radio, a better unit to use is the millihenry (mH). This is one thousandth of a Henry. An even smaller unit is the microhenry (μH), and this is just one millionth of a Henry. The more turns on the coil, the higher its inductance.

A typical coil in a short wave receiver might have an inductance of 5mH. The coil on a crystal set for medium wave (AM) reception on the other hand, could be 100mH. Audio equipment might have inductors of 10mH or more. Turn to our Crystal Set feature on page 6, and look at the coil. Like all modern portable radios which cover the medium and long (AM) broadcast bands, it has an aerial coil wound on a ferrite rod.

Some coils are adjustable, like the one shown in **Fig 1**.

FUNCTIONS OF FERRITES

SO WHAT IS FERRITE? In simple terms, it's a high-resistance magnetic material mainly made up of ferric oxide (the substance used to coat magnetic recording tapes) and one or more other metals, combined with a ceramic material. Ferrite has special properties which make it especially suitable for use in the reception of radio signals at low frequencies.

When connected to a capacitor, we have what is known as a **Tuned Circuit**. This picks up signals at one

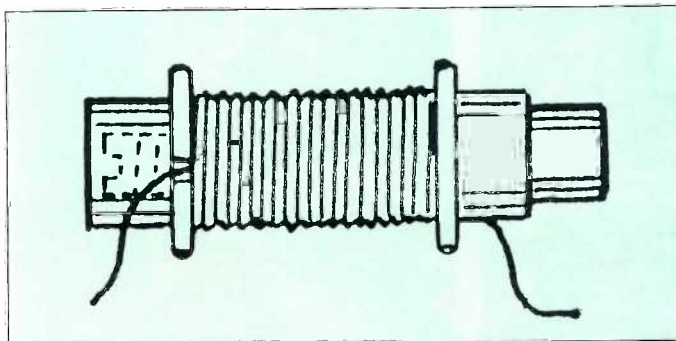

Fig 1: You may well find this type of coil in a short wave receiver. It has an adjustable ferrite core, with which to vary its inductance.

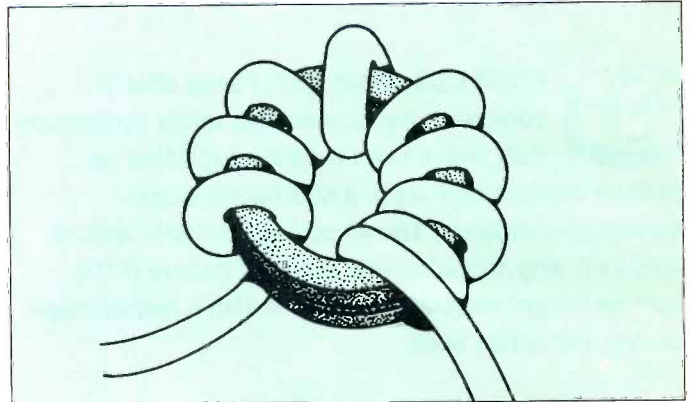

Fig 2: Cables can be wound on circular ferrite rings called toroids. This helps to stop interference picked up by the cable from entering a radio set.

frequency which is selected by turning the vanes of the tuning capacitor or varying the voltage on a varicap diode. The signal can then be passed on to a diode detector and converted to an audio signal.

Sometimes, extra stages (known as Radio Frequency or RF amplifiers) are placed between the aerial tuned circuit and detector. An interesting feature of ferrite rod antennas is that they must be turned to about a 90° angle to the transmitting station for best reception.

Sometimes a smaller coil is wound over the main one. This matches the impedance of the tuned circuit to the amplifier input for best reception. In other cases a tap (wire connection) on the coil does the same thing.

RINGS AND BEADS

FERRITE CAN BE USED in the construction of transformers for radio frequencies. A typical use for one of these is to match an antenna to a short wave receiver, so that you receive the best signal.

What else can we do with ferrite materials in radio? Well, cables can be wound on circular ferrite rings, known as **toroids**. A toroid is shown in **Fig 2**, and this is often a useful way of preventing electronic equipment picking up unwanted signals. Very small rings known as ferrite beads are used in VHF equipment. A single wire passed through a hole in the bead produces a small value of inductance.



D-i-Y HAM FACTS

What is a Varicap?

VARIABLE CAPACITANCE DIODES



IN D-i-Y RADIO Vol 2: No 2, Ham Facts explained how variable capacitors are used to tune into different stations on a radio set.

Instead of having fixed and variable plates to vary the capacitance, we can use a different component called a 'variable capacitance' or varicap diode. This component changes its capacitance when the voltage across its leads is varied (Fig 1).

The varicap diode (or varicap for short) has the advantage of being very small, and it is usually cheaper than a capacitor with moving plates. Varicaps are available with different values of capacitance, from less than 20pF (pico-Farad) for VHF radios, to 500pF for MW and LW sets. For most circuits, the voltage is varied between about 2V and 9V to change the value of capacitance. We used varicaps for tuning stations in the Yearling 20 metre receiver featured in *D-i-Y Radio* Vol2: No 4.

In some radios, it is important that several circuits are all tuned to the same frequency. This means we are increasing the radio's **selectivity** - it's ability to accept one signal, but reject those on other channels. Special dual and triple varicaps are available, which have very nearly the same capacitance at any particular voltage. Like nearly all circuits using diodes, it is important that you wire them the right way round (in other words the polarity must be correct).

Now take a look at the circuit diagram in Fig 1. The

varicap diode shown here is said to be **reverse biased**. This means that although there is a voltage across its terminals, no current flows through the device. In a real circuit, a coil would be connected across terminals A and B, with a large capacitor in series to prevent a DC short circuit.

Unfortunately, variations in temperature can cause the capacitance to change. When the varicap is used in an oscillator this, in turn, would cause the frequency to drift, and you would have to keep re-tuning the radio! Luckily there is a way of correcting the frequency drift using a special type of integrated circuit (IC) called a **phase locked loop**.

All modern TV sets and satellite receivers use varicap diodes and the phase locked loop works out the correct varicap voltage for each channel.

SOME USEFUL VARICAP DIODES

| Type No. | pF/V | pF/V | Description |
|----------|---------|--------|-------------|
| BB204B | 42/2.0 | 15/12 | Dual VHF |
| BB212 | 560/0.5 | 22/8 | AM tuning |
| KV1235 | 450/2.0 | 30/8.5 | Triple AM |
| KV1236 | 450/2.0 | 30/8.5 | Dual AM |
| MV1404 | 120/2.0 | 9/10.0 | HF tuning |

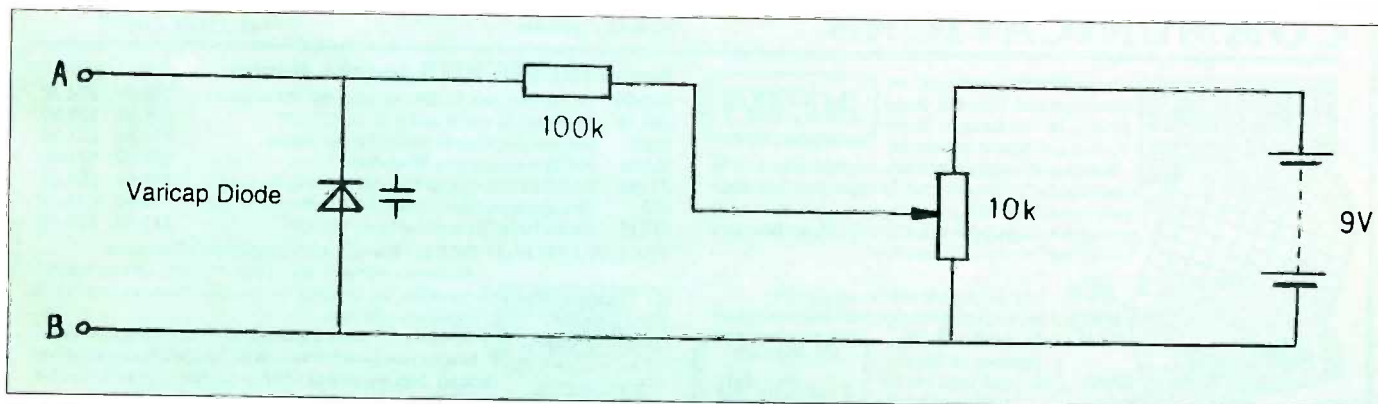

Fig 1: The capacitance of the varicap diode (between A and B) increases as the voltage is reduced, using the variable resistor.

Readers' Letters

Keep sending your letters and photographs to the Editor, D-i-Y Radio, RSGB, Lambda House, Cranborne Road, Potters Bar, Herts, EN6 3JE, and we will send a pen to the sender of each letter published.

KEEP IT UP

We enjoy the mag very much, please keep up the good work.

The Cooper Family, Co Durham.

CALENDAR

| | |
|-----------|---|
| 20-21 Feb | Guides Thinking Day on the Air |
| 8 Mar | Novice Radio Amateurs Examination (RAE) |
| 16 May | RSGB'93 Exhibition, NEC Birmingham |
| 7 Jun | Novice RAE |
| 18 July | RSGB National Amateur Radio Rally, Woburn, Beds |
| 13 Sep | Novice RAE |
| 6 Dec | Novice RAE |

RADIO 'HAM'

Please find enclosed a postal order for my subs for 1992-93 *D-i-Y Radio*. You will notice by my address I am now a Novice licensee, not bad for 79 years and 3 months and my only connection was with currants - not currents - being a GPO cook on completion of my twelve years in the Royal Navy.

I was hoping I would receive a photograph of myself, and two young lads who passed with me, being presented with the diplomas here in Pontypool by the Torfaen Mayor.

Anyway I shall send a copy on to you.

Charlton Cole, 2W1BFK, Gwent.

Well done - I look forward to receiving a photo of you soon, and if room allows I will publish it. If your cookery extends to Microwaves you're well on the way to becoming an excellent radio amateur! - Marcia.

MORSE CODE NOTES

Last issue I asked you in Morse code to write to me - here are some of your notes:

I've much enjoyed your magazine. It is very interesting. - Jack Thompson, Sheffield.

I hope I win an Icon receiver. 2M1BAX weather reports snow. - Ewan, 2M1BAX.

I hope I win an Icon receiver. - Tom Irwin, Derbyshire.



FIRST OF ALL may we at *D-i-Y Radio* wish you a very happy and prosperous New Year. Make it your New Year resolution to go along to your nearest amateur radio club or find out where there is a Novice RAE course near you, write to me if you need help with this. The dates for the exam are shown in our calendar, so you can plan ahead.

We start 1993 with a major new technical series by the Rev George Dobbs, G3RJV, who will be showing you how to build an 80 metre receiver step by step. In each issue he will be showing you how to build a module and full kits will be available for each one. When completed you will have a receiver which will give excellent reception and that you will feel proud of having built yourself.

Of course, we will still offer you other projects to complete including some aimed at Novice Licensees.

If there is any particular subject you would like us to cover, please write and tell us.

This is your magazine so let us have your views.

Marcia Brimson - Editor

C.M. HOWES COMMUNICATIONS

Mail Order to: Eydon, Daventry, Northants NN11 6PT
Tel: 0327 60178

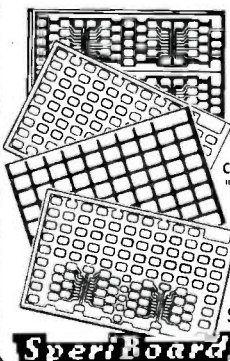

The new HOWES "SperiBoards" are general purpose PCBs that should prove to be very handy for Novice training and general prototyping. These boards are designed to be much more suitable for RF use than the "strip board" type. Two styles have their solder pads surrounded with a ground plane, so a short earth connection is always to hand! Size: 160 by 100mm. Keep a few "SperiBoards" handy in the workshop!

NEW!

| Type | Description | Price |
|-------|--|---------------------------|
| SF01S | .4 by .5 inch pads with two supply rails. | £2-90 each 4 for £9-90 |
| SF02S | .2 by .4 inch pads with supply rail and ground plane | |
| SF03S | .2 by .3 inch pads with provision for four ICs. | |
| SF04S | .2 by .3 inch pads, two ICs and ground plane. | |

Some HOWES KITS for the Novice

| Kit | Assembled PCB | |
|--------|---|---------------|
| DcRx80 | SSB and CW receiver for 80M band (also 20 & 40M versions) | £15.90 £22.70 |
| DXR10 | Three band SSB and CW receiver for 10, 12 & 15M | £26.60 £39.90 |
| TRF3 | Shortwave Broadcast TRF receiver (AM plus SSB/CW) | £15.50 £21.70 |
| CTX80 | 80M CW Transmitter up to 5W adjustable | £14.80 £21.80 |
| AT160 | AM/DSB/CW Transmitter for 80 & 160M, super quality signal | £39.90 £61.80 |
| ST2 | CW Side-tone and Morse practice oscillator with sine-wave note. | £8.90 £14.30 |
| CTU30 | Antenna Tuning Unit (covers all bands, 160 to 6M) | £31.50 £38.40 |

PLEASE ADD £1.50 P&P for boards, kits or assembled modules.



Novice Transceiver

We have lots of other kits in our range! Kits can be combined to form a transceiver. Our transceiver "hardware packs" have pre-finished front panels and look superb. All HOWES KITS contain a good quality PCB with printed parts location, full instructions and all board mounted components. Send an SAE for free catalogue. Sales and technical advice are available by phone during office hours. Delivery is normally within 7 days. 73 de Dave, G4KQH

DI-DI-DAH-DAH-DI-DIT

Win a Super Gas Soldering Iron

NIMROD HAVE DONATED one of their new T-100 soldering irons as our first prize in this competition. It is powered by butane gas-lighter fuel (not supplied) and is fitted with a 1mm soldering tip. The iron works like any other soldering iron but inside there is a small flame heating the bit. This iron can be purchased from the Nimrod Company, PO Box 1534, Marlborough, Wiltshire SN8 1ZY, or from Greenwood Electronic Components, Kyppings House, Ravensworth Road, Mortimer, Reading, Berks RG7 3UD. Price is £21.65 (inc VAT and postage).



WINNERS!

JOTA COMPETITION (Sept/Oct issue):

1st prize: Jean Kerrigan from Huddersfield wins the Altai Multimeter.

2nd prize: Ben Taylor from Faringdon in Oxfordshire wins an RSGB Receiving Log Book.

WORD PUZZLE (Nov/Dec issue):

1st prize: Mr M Hampson of Chesterfield wins the Icon Airband broadcast receiver. **2nd prize:** Tee shirts go to Mr J De Frece from Sheffield, and Rupert Jabelman from Reading: **3rd prize:** Kodak drink holders go to Douglas Goulburn from Hemel Hempstead and Mike Williams, 2E0ABU, from Dorset.

CODED MESSAGE

Decode this message by using the Morse code on your subscriber's card.

di-dah dah-dit dah-dah-dah dah di-di-dit dit di-dah-dit di-dah-dah di-dit dah-dit dah-dit dit di-dah-dit di-di-dah-dit di-dah-dit dah-dah-dah dah-dah dah di-di-di-dit dit dah-dit di-dit dah-di-dah-dah di-dah-dit di-dah dah-di-dit di-dit dah-dah-dah di-di-dit dah di-dah dah-di-di-dit di-dah-di-dit dit

CLUES ACROSS

1. Commercial stations can do this. (9)
8. Each progresses at his/her own. (4)
9. Centre. (3)
11. A diode is this kind of conductor. (4)
16. Use this to mend a broken wire. (6)
17. When your station is this you add a suffix to your callsign. (6)
19. Do this with your receiver knob. (4)
21. Goes with 21 across to make A or N. (3)
23. Do this to 4 down. (4)
24. Articles in *D-i-Y Radio* are often this. (9)

CLUES DOWN

2. Hams are never this on the air. (4)
3. A rainbow makes one in the sky. (4)
4. Join an RSGB affiliated one. (4)
5. A long-wire antenna does this in summer. (4)
6. A ham presses the PTT switch and ----- (9)
10. A Morse key has a specific one. (3)
12. Do this regularly to your equipment. (4)
13. The 'Yearling' uses a varicap type cut into two. (5)
14. Amateur radio appeals to young and --- (3)
15. Buy one to build the 'Yearling'. (3)
18. A good place for a ham to use a handheld rig to keep in touch. (3)
20. Part of a battery. (4)
21. There's one in T. (4)
22. Anthony finds this a Morse abbreviation. (4)
23. Scouts Day on The Air. (4)

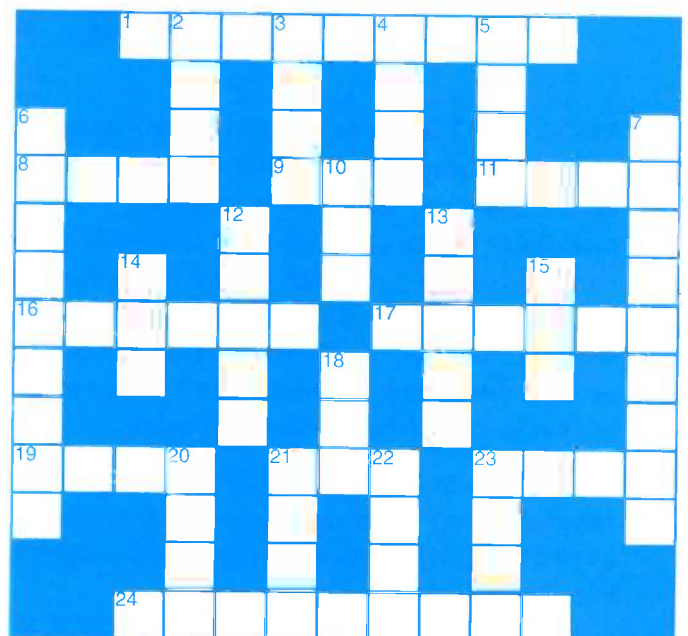

Managing Editor: Mike Dennison; Editor: Marcia Brimson; Production Ed: Sid Clark; Tech Ed: Paul Lovell; Draughtsman: Derek Cole; Secretary: Erica Fry; Typist: Belinda Gannon. *D-i-Y RADIO* is published six times a year by the Radio Society of Great Britain, Lambda House, Cranborne Road, Potters Bar, Herts. Filmed by JJ Typographics Ltd. Printed by Southernprint (Web Offset) Ltd. © Radio Society of Great Britain, 1992. All rights reserved. No part of this publication may be

reproduced, stored in a retrieval system, or transmitted, in any form or by any means, electronic, mechanical, photocopying, recording or otherwise, without the prior written permission of the RSGB. All reasonable precautions are taken by the Radio Society to ensure that the advice and data given to our readers are reliable. We cannot however, guarantee it and we cannot accept legal responsibility for it. Prices quoted are those current as we go to press. ISSN No: 0959-843X.

Become a regular D-i-Y'er

Get **D-i-Y Radio** for the next year* plus

- * A "Can't wait for my Novice Licence" badge
- * A plastic wallet so you can keep your issues of **D-i-Y Radio** Safe
- * An RSGB Map of Western Europe (900mm wide and 1200mm high)
- * An RSGB pen
- * A D-i-Y Club card
- * Money-off vouchers

... all for the special introductory price of only **£9!**

*RSGB Members see RadCom for details of special offer
Overseas Subscribers write for prices.*

Please let us know your age or the age of the person for whom you are buying **D-i-Y Radio** and where you saw this copy.

**(D-i-Y Radio is published six times a year)*

Send cheques or postal orders, made payable to:



**RSGB, Lambda House, Cranborne Road,
Potters Bar, Herts, EN6 3JE.**

Amateur Radio for Beginners

Find out all about Amateur Radio — this book by Victor Brand, G3JNB, explains:

- ✓ how to build a crystal set
- ✓ how to listen to radio amateurs
- ✓ how to understand morse code
- ✓ how to choose equipment
- ✓ how to get a transmitting licence

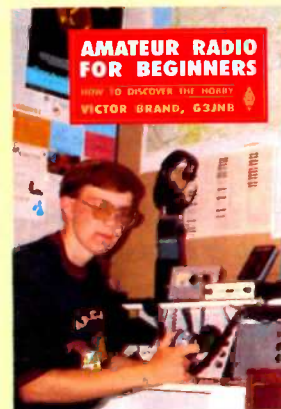

Available from the Radio Society of Great Britain.

Price: **£3.50** (plus £1 post & packing)

Send cheques or postal orders, made payable to:



**RSGB, Lambda House, Cranborne Road,
Potters Bar, Herts, EN6 3JE.**

Amateur Radio and the RSGB

RADIO AMATEURS are qualified radio operators who are licensed to talk to other operators, often in distant countries, from their own homes. Amateur radio is a hobby for all ages but it is different from CB radio because a very wide variety of frequencies (wavelengths) can be used, and contacts can be in different 'modes'; by Morse code or teleprinter, between computers or even television. Many amateurs build all or part of their station equipment.

The Radio Society of Great Britain (RSGB) is the national society for all radio amateurs (transmitters and listeners) in this country. It has 35,000 members, including many in overseas countries.

The Society looks after the radio amateur by arranging better licence conditions with the Government. It is through these talks with the Government's Radiocommunications Agency that the Novice Licence has come about. The RSGB is keen to encourage young people to learn about electronics and radio. We are having lots of fun with our hobby and want you all to join in. Who knows, it may lead to a fascinating and well-paid job in the future.

If you require more information on the RSGB or the Novice Licence, write to Sylvia Manco for an Information Pack, enclosing a large stamped self-addressed envelope, at:



RSGB, Lambda House, Cranborne Road, Potters Bar, Herts. EN6 3JE.